

Load-Switch IC

1. Introduction

The load-switch IC consists of an output transistor and driving circuit in a single chip.

Usage of the load-switch IC can be found in the following application:

- Smartphone ●Mobile phone ●Tablet ●Digital camera
- Portable gaming device ●Notebook PC and accessories ●Portable AV equipment etc.

Particularly, it is used to meet the need for small discrete devices in smartphone, tablets where there are strict power requirements, and performance is important. Also, a range of power management devices are required.

To respond to these needs, multiple power supply ICs have been offered in a single power supply IC (Power Management IC; PM-IC), however, as newer smartphone and tablets have better specification and contain increasing number of functions, the number of channels and power supply quality of the PM-IC may not suffice. In such case, the load-switch IC can supplement the PM-IC.

The load-switch circuit normally comprises of discrete MOSFETs, however as the load-switch IC can replace the multiple devices needed in discrete circuits, it saves space, and yet provides additional function to which a discrete MOSFET circuit cannot provide. It is highly suitable as a simple power management solution for complex systems.

Load-switch ICs have the following merits as compared to discrete circuits.

- Less devices thus saving space
- Over temperature protection, over current protection and other protection features
- Inrush current reduction and power supply sequence control reducing circuit design work
- Low drive voltage guarantee
- Full temperature range guarantee

This application note will introduce the load-switch IC and its basic circuit. We hope that you will find it useful.

2. Load-switch IC basics

The following section explains the basics of load-switch ICs.

•Load-switch IC basic circuit

The load-switch IC basic circuit is as shown in Fig.1

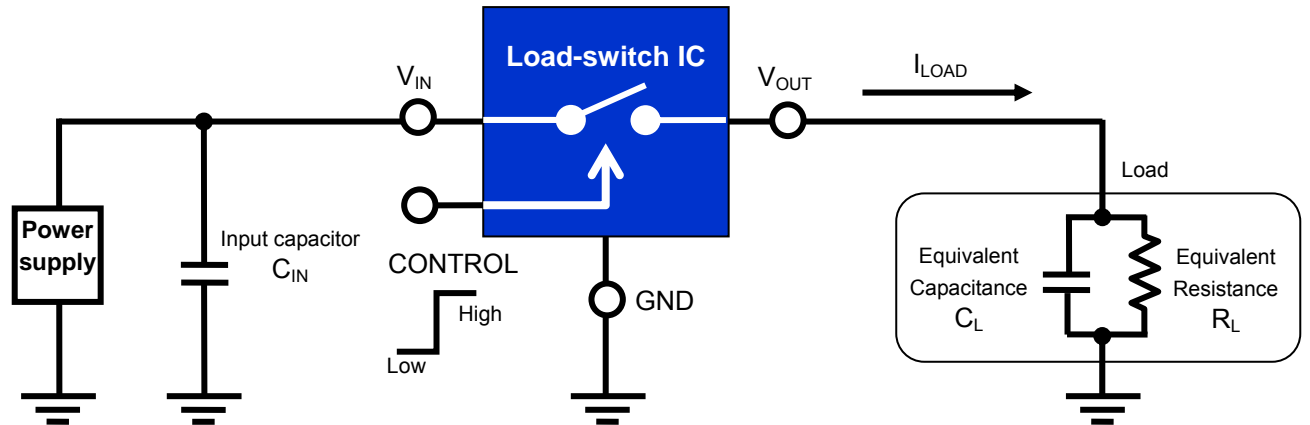

Fig.1 Basic load-switch IC example

Load-switch IC is connected to the power supply with the input pin V_{IN} , connected to the load at the output pin V_{OUT} , and has a CONTROL pin (Also known as Shutdown pin, Enable pin) with logic control to turn the load-switch IC ON/OFF. The output voltage V_{OUT} depends on the input voltage V_{IN} and the corresponding equivalent load resistance R_L and thus output current I_{LOAD} , the output voltage is then the input voltage minus the dropout voltage due to the internal resistance of the output transistor element in the load-switch IC and the output current.

$$\text{Output voltage } V_{OUT} = \text{Input voltage } V_{IN} - (\text{Output current } I_{LOAD} \times \text{Resistance of output transistor})$$

Generally, compared to the output transistor used in LDO regulator (Low Drop-out regulator, LDO) IC, a rather low resistance transistor is used, so it can be used from the comparatively low load of under 100mA to applications that require up to 500mA and above.

The power supply source is usually a lithium ion battery or the output of a PM-IC. Especially for switching power supplies using a PM-IC at the input voltage V_{IN} , there is likely to be noise (ripple). The ideal power supply is to use an LDO to remove this noise, but as mentioned above, LDO is usually limited to light load applications and require high input voltage. (For more details on LDO, please refer to our LDO application note) The load-switch IC uses the power supply as it is and only acts as a switch for the load, thus it does not remove any noise. For stability it is recommended that an input capacitor C_{IN} be used. Also, load-switch ICs typically have various embedded additional functions, depending on the product type. These functions and the block diagrams will be explained with Toshiba's TCK10xG series as an example below.

•Load-switch IC function table and Block diagram

The load-switch IC functions are shown in Fig.1, and block diagram in Fig.2.

Product name	Function				
	Inrush reduction	Thermal shutdown	Overcurrent protection	Output auto-discharge	Control pin connection
TCK101G	Built in	Built in		Built in	Pull down (Active High)
TCK102G	Built in	Built in			
TCK104G	Built in	Built in	Built in (Available up to 500mA)	Built in	
TCK105G	Built in	Built in	Built in (Available up to 800mA)	Built in	
TCK106G	Built in				
TCK107G	Built in			Built in	
TCK108G	Built in			Built in	

Fig.1 TCK10xG function table

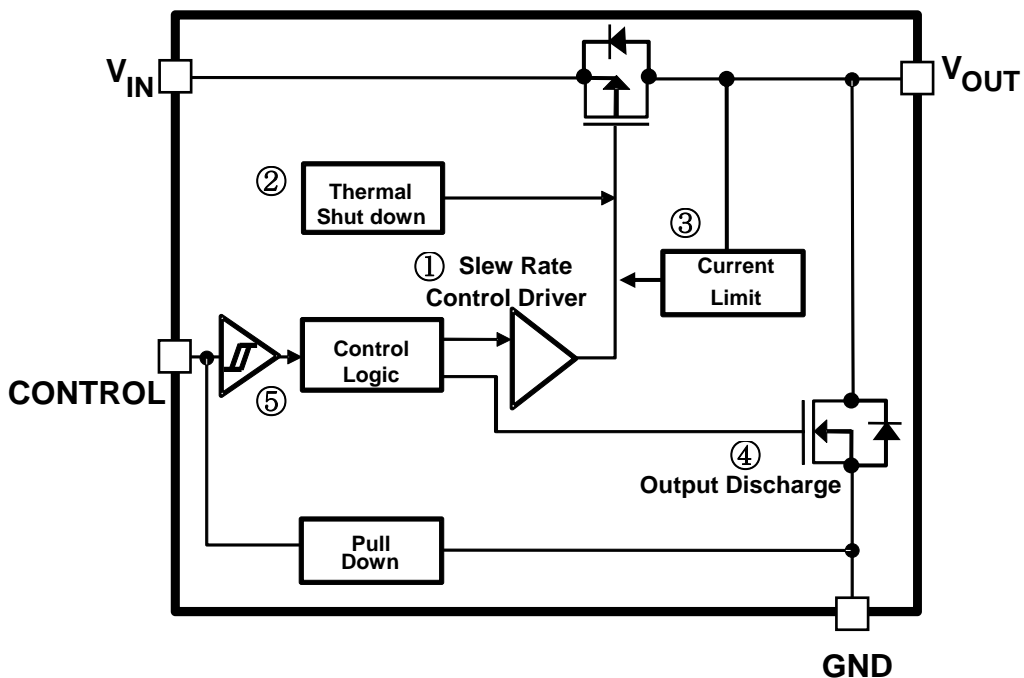

Fig.2 TCK104G, TCK105G Block diagram

The following will briefly explain each circuit and function

① Inrush current reduction circuit (Slew Rate Control Driver)

The slew rate control driver is used to control inrush current caused by switching transients. The inrush current caused by each individual switching can cause the PM-IC which provides power supply to a range of devices, to temporarily exceed its maximum available current, causing it to shutdown or result in operation error and system trouble. Also, a similar situation might occur on the load side, such that an inrush current reduction circuit is required.

The inrush current is controlled by the slow-start circuit in the driver circuit, equivalent load capacitance C_L and equivalent load resistance R_L , which alters the rise time of the output voltage V_{OUT} and thus the transient inrush current. Also, other than the methods mentioned above, using the overcurrent protection circuit ③, the rising output current can be controlled, and the inrush current is reduced. The block diagram shown in Fig.2 is that of TCK104G, TCK105G which have overcurrent protection circuits and uses this method. Fig.3 shows how this inrush reduction circuit works.

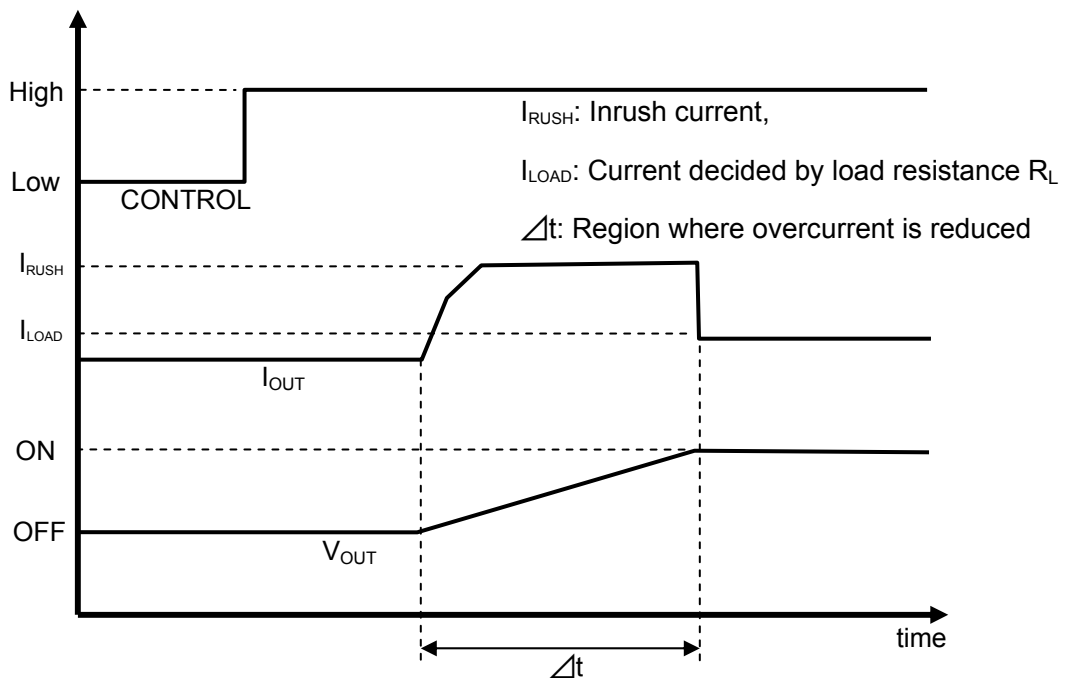

Fig.3 TCK104G,TCK105G inrush current reduction image

The region shown by Δt where V_{OUT} increases gradually, uses the current limiter (I_{CL}) of the overcurrent protection as explained later to control the inrush current. During actual use, the result might change pending on input voltage V_{IN} (\approx output voltage V_{OUT}), and the load capacitance and load resistance.

② Over temperature protection circuit (Thermal Shutdown; TSD)

The circuit prevents excessive heating and damage to the device caused by unintentional current and large load current, and also from increase in ambient temperature. The internal temperature sensing circuit detects when temperature exceeds the specified temperature, and turns the output transistor ON/OFF. For TCK10xG series, this specified temperature is above the absolute maximum chip junction rating (T_j) of 150°C .

The operation of the over temperature protection circuit is shown in Fig.4. It has a determined hysteresis which depending on the temperature and automatically turns it ON/OFF.

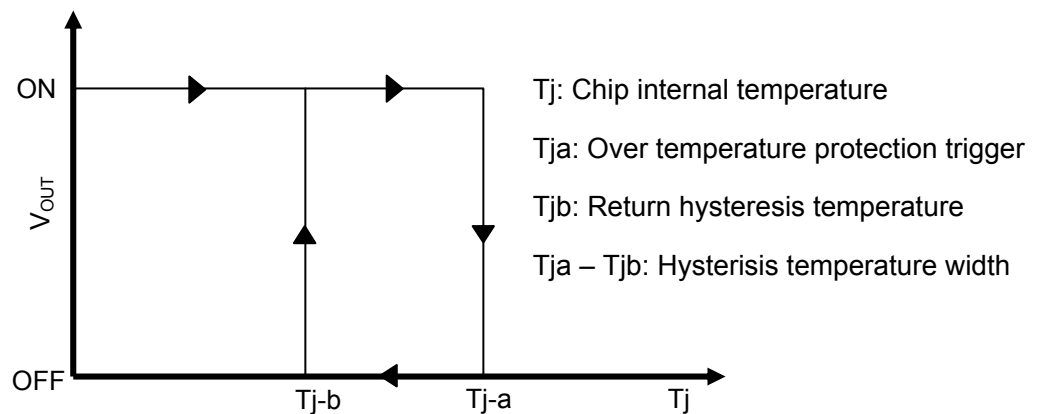

Fig.4 Over temperature protection circuit image

Also, the over temperature protection circuit and the hysteresis return temperature for TCK10xG are not used to guarantee that the device operates within the absolute maximum ratings. Please read through and understand dissipation idea for absolute maximum ratings from our 'Semiconductor Reliability Handbook'. Then use these products under absolute maximum ratings in any condition. Furthermore, Toshiba recommend inserting failsafe system into the design.

③ Overcurrent protection circuit (Current Limit)

Essentially, this feature protects the product from damage when short circuit occurs at the output V_{OUT} pin. It is also known as current limit.

Fig.5 shows the overcurrent protection operation of TCK10xG, using a fold back type circuit. This is the same as the commonly used protection circuits in LDOs.

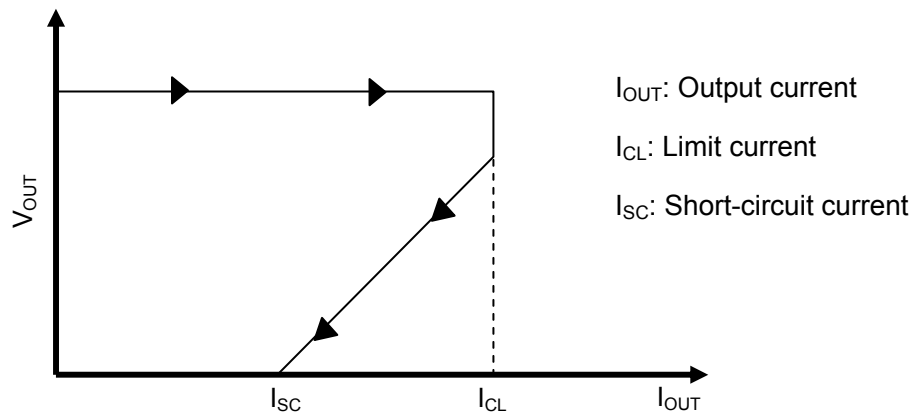

Fig.5 Overcurrent protection circuit operation image

If the output pin V_{OUT} is in short mode, as output current I_{OUT} exceeds the designed limit current I_{CL} , the overcurrent protection circuit kicks in, and the output current and output voltage is reduced as shown above. When it is in complete short mode ($V_{OUT} = GND$), $V_{OUT} = 0V$ and $I_{OUT} = I_{SC}$. When released from short mode, the load-switch IC will return to normal operation.

However, if the output pin is not fully in short mode and in semi-short mode, the above will not occur. Since the input voltage $V_{IN} (= \text{output voltage } V_{OUT})$, the operation point for I_{CL} will differ.

Please take note that the overcurrent protection circuit for TCK10xG, like the over temperature protection circuit, is not designed to guarantee that the device will be kept within maximum ratings.

④ Output auto-discharge circuit

When the output transistor of the load-switch IC is turned OFF from ON state, the capacitor connected to the output pin maintains a certain voltage at the V_{OUT} pin for a period of time. If there are multiple power sources and there is a need to keep a strict timing of the power supplies for the load, it is hard to control the load operations properly. To solve this issue, an output auto-discharge circuit is necessary.

The output auto-discharge circuit is important to quickly remove electric charge gathered in the elements connected to the output pin V_{OUT} . Fig.6 shows the case when an auto-discharge circuit and when there is no auto-discharge circuit.

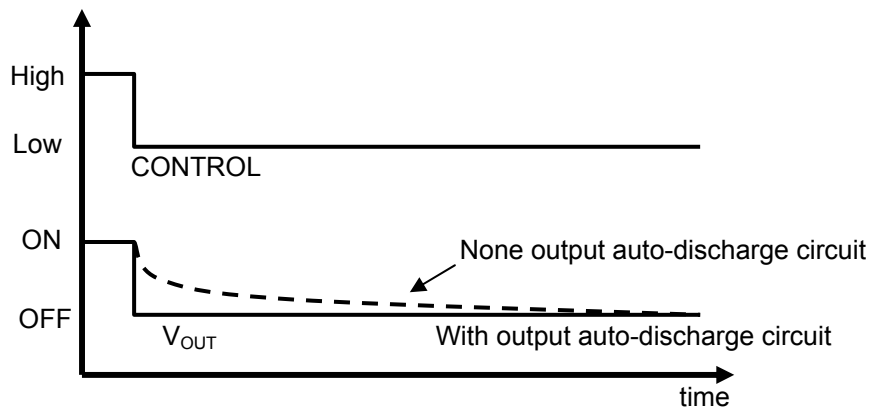

Fig.6 Image comparison between devices with and without Output auto-discharge circuit

⑤ Control logic circuit

Control logic circuit, with power supply of input voltage V_{IN} , is the circuit used to operate the output transistor and output auto-discharge transistors. The control circuit in TCK10xG series, available in both Active High and Active Low, turns the device ON/OFF using an input Schmitt logic control voltage. TCK104G, TCK105G are Active High products with output auto-discharge circuit, so when it is High, the output transistor is ON, and discharge transistor is OFF, and vice versa when it is Low. As the control pin is connected to the GND pin with a pull-down connection of a few $M\Omega$, the IC will be in OFF state when the voltage at the control pin is unstable (Open status). Also, as the control pin has a tolerant function, even if the control voltage is higher than the input voltage V_{IN} , there will not be leakage.

This brings us to a conclusion of the load-switch IC basic circuit and functions. There are different additional functions for various devices, so it is best to choose the device that best fits the circuit and load requirements. Following this, the electrical characteristics will be explained.

3. Load-switch IC electrical characteristics and usage precautions

The datasheet and the precaution measures will be explained here.

Except for AC characteristics and a section of DC characteristics, the specifications for TCK10xG series is specified at whole operating temperature range ($T_a = -40$ to 85°C). The following explanation will use Toshiba's TCK101G and TCK102G as examples.

•Electrical DC characteristics

1) Input voltage <Symbol : V_{IN} >

Input voltage refers to the operating range of the load-switch IC. The operation of the load-switch IC including the output transistor, control circuit, over temperature protection circuit, discharge circuit, etc. for TCK101G and TCK102G are specified to operate at all temperatures from 1.1V to 5.5V.

Characteristics	Symbol	Test Conditions	$T_a = 25^\circ\text{C}$			$T_a = -40$ to 85°C		Unit
			Min	Typ.	Max	Min	Max	
Input Voltage	V_{IN}	-	1.1	—	5.5	1.1	5.5	V

Fig.7 TCK101G, TCK102G input voltage specifications

2) Control Voltage <Symbol : V_{IH} , V_{IL} >

This is the specification for control logic High or Low. Specifications for Active High TCK101G and TCK102G are shown Fig.8

Characteristics	Symbol	Test Conditions	$T_a = 25^\circ\text{C}$			$T_a = -40$ to 85°C		Unit
			Min	Typ.	Max	Min	Max	
CONTROL High-level input voltage	V_{IH}	$1.2\text{V} < V_{IN} \leq 5.5\text{V}$	1.0	—	—	1.0	—	V
		$1.1\text{V} \leq V_{IN} \leq 1.2\text{V}$	0.9	—	—	0.9	—	
CONTROL Low-level input voltage	V_{IL}	$V_{IN} = 1.1 \sim 5.5\text{V}$	—	—	0.4	—	0.4	V

Fig.8 TCK101G, TCK102G control voltage specifications

3) Quiescent current (ON) <Symbol : I_Q >

This is the consumption current for the load-switch IC in ON state. For Fig.9 shows the specifications for TCK101G and TCK102G. This value includes the current flowing between the control pin and GND via the pull-down.

Characteristics	Symbol	Test Conditions	Ta = 25°C			Ta = -40to85°C		Unit
			Min	Typ.	Max	Min	Max	
Quiescent current (ON state)	I_Q	$I_{OUT} = 0 \text{ mA}$, $V_{IN} = V_{CT} = 5.5 \text{ V}$	—	8	—	—	20	μA

Fig.9 TCK101G, TCK102G Quiescent current (ON state) specifications

4) Quiescent current (OFF state) <Symbol : $I_{Q(OFF)}$ >

Fig.10 shows the consumption current of the load-switch IC during OFF state.

When $V_{IN}=5.5\text{V}$, $V_{CT}=0\text{V}$, for TCK101G, the discharge transistor is ON state. This current does not include the current which flows from the input voltage pin V_{IN} for TCK101G through the output transistor in OFF state and the discharge transistor which is turned ON to GND. (The output discharge transistor leak is explained in 5: OFF-state switch current). As TCK102G does not have a discharge circuit, the above does not apply.

Characteristics	Symbol	Test Conditions	Ta = 25°C			Ta = -40to85°C		Unit
			Min	Typ.	Max	Min	Max	
4)Quiescent current (OFF state)	$I_{Q(OFF)}$	$V_{IN} = 5.5 \text{ V}$, $V_{CT} = 0 \text{ V}$, $V_{OUT} = \text{OPEN}$	—	0.07	—	—	1	μA

Fig.10 TCK101G, TCK102G Quiescent current (OFF state) specifications

5) OFF-state switch current <Symbol : $I_{SD(OFF)}$ >

The leak between input V_{IN} —output V_{OUT} when output transistor is in OFF state as shown in Fig.11.

Characteristics	Symbol	Test Conditions	Ta = 25°C			Ta = -40to85°C		Unit
			Min	Typ.	Max	Min	Max	
OFF-state switch current	$I_{SD(OFF)}$	$V_{CT} = 0\text{ V},$ $V_{OUT} = \text{GND}$	$V_{IN} = 5.0\text{ V}$	—	10	—	—	1000 (Note2)
			$V_{IN} = 3.3\text{ V}$	—	2	—	—	1000
			$V_{IN} = 1.8\text{ V}$	—	1	—	—	1000
			$V_{IN} = 1.2\text{ V}$	—	1	—	—	1000

(Note 2): Ta = 65°C

Fig.11 TCK101G, TCK102G OFF-state switch current specifications

6) On resistance <Symbol : R_{ON} >

On resistance for output transistor. TCK10xG series uses the p-ch MOSFET for its output and as input voltage gets higher, the voltage at this MOSFET's gate will increase and the resistance is decreased. Fig.12 shows this specifications.

Characteristics	Symbol	Test Conditions	Ta = 25°C			Ta = -40to85°C		Unit
			Min	Typ.	Max	Min	Max	
On resistance	R_{ON}	$I_{OUT} = 500\text{ mA}$	$V_{IN} = 5.0\text{ V}$	—	50	—	—	70
			$V_{IN} = 3.3\text{ V}$	—	55	—	—	75
			$V_{IN} = 1.8\text{ V}$	—	75	—	—	100
			$V_{IN} = 1.2\text{ V}$	—	120	—	—	180
			$V_{IN} = 1.1\text{ V}$	—	155	—	—	—

Fig.12 TCK101G, TCK102G On resistance specifications

7) Discharge on resistance <Symbol : R_{SD} >

On resistance for output discharge transistor. Fig.13 shows the specifications for TCK101G.

Characteristics	Symbol	Test Conditions	Ta = 25°C			Ta = -40to85°C		Unit
			Min	Typ.	Max	Min	Max	
Discharge on resistance	R_{SD}	— (TCK101G)	—	100	—	—	—	Ω

Fig.13 TCK101G Output Discharge on resistance specifications

•AC electrical characteristics

It is important to understand switching characteristics for power supply timing and control. The switching characteristics for TCK101G's output voltage rise time and fall time are shown in Fig.14. (Specified at $T_a = 25^\circ\text{C}$)

Characterisitcs	Symbol	Test conditions	Min	Typ.	Max	Unit
V_{OUT} rise time	t_r	$V_{IN}=3.3\text{V}$, $R_L=500\Omega$, $C_L=0.1\mu\text{F}$	—	170	—	μs
V_{OUT} fall time	t_f	$V_{IN}=3.3\text{V}$, $R_L=500\Omega$, $C_L=0.1\mu\text{F}$	—	45	—	μs
Turn on delay	t_{ON}	$V_{IN}=3.3\text{V}$, $R_L=500\Omega$, $C_L=0.1\mu\text{F}$	—	135	—	μs
Turn off delay	t_{OFF}	$V_{IN}=3.3\text{V}$, $R_L=500\Omega$, $C_L=0.1\mu\text{F}$	—	10	—	μs

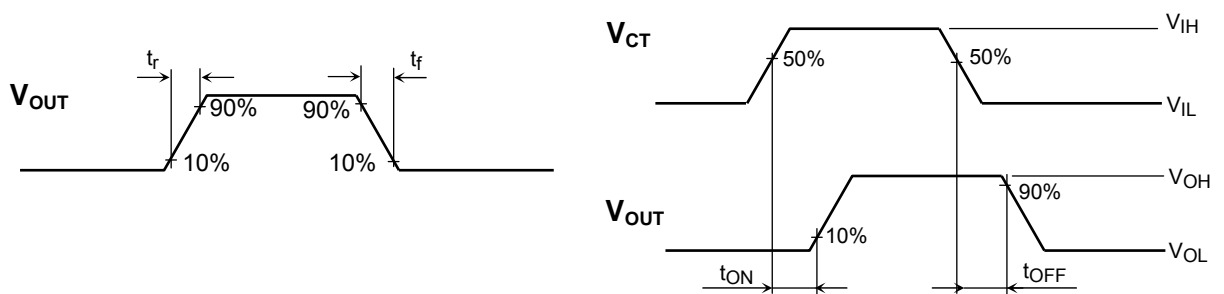

Fig.14 TCK101G switching specifications

To control the inrush current in TCK101G, TCK102G, there is a slow-start circuit in the driver for the output transistor. This and input voltage V_{IN} , equivalent load resistance R_L , equivalent capacitance C_L affects the output rise and fall time. C_L particularly affects inrush current. Fig. 15 shows the circuit used when measuring inrush current, while Fig. 15, 16 shows the standard TCK101G switching curve (dependent on capacitance).

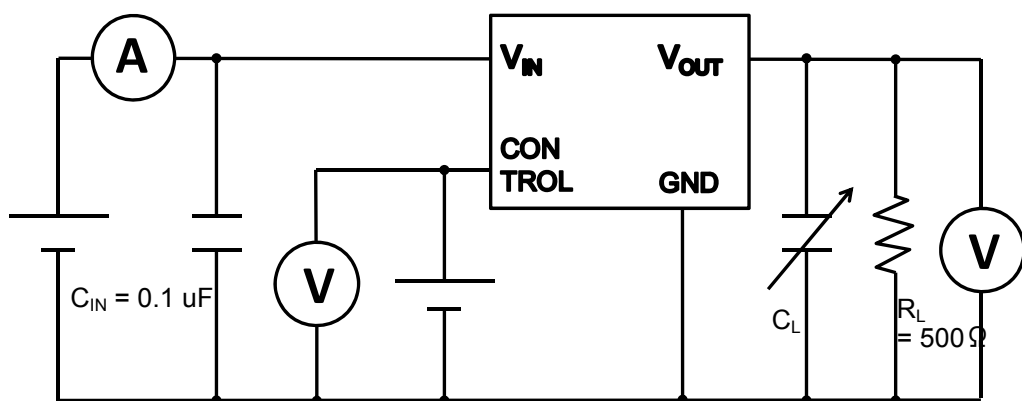

Fig.15 TCK101G inrush current measurement circuit

Note that input capacitance $C_{IN} = 0.1 \mu\text{F}$ and load resistance $R_L=500 \Omega$ is used for measurements at $T_a=25^\circ\text{C}$.

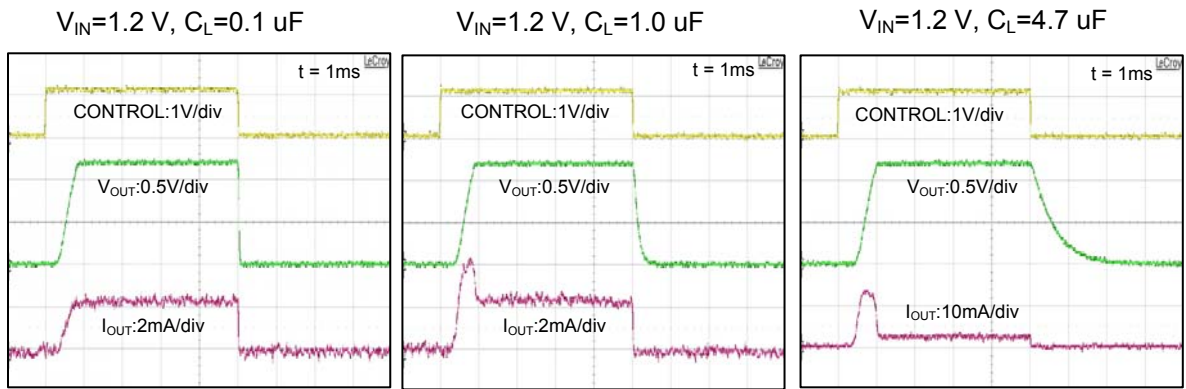

Fig.15 TCK101G $V_{IN} = 1.2\text{ V}$ switching curve

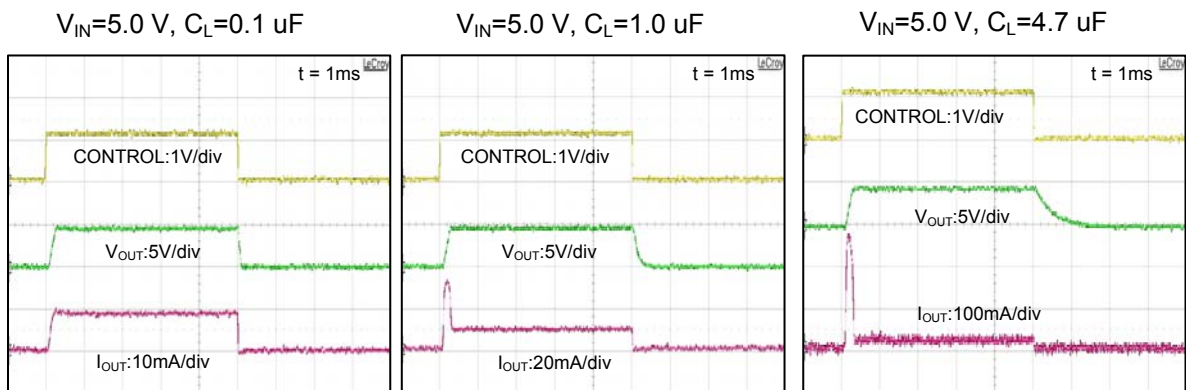

Fig.16 TCK101G $V_{IN} = 5.0\text{ V}$ switching curve

Load capacitance for Fig.15, 16 increases from 0.1uF to 4.7uF, showing the increase in I_{OUT} , also note that input voltage plays an important part, as seen in the different 1.2V and 5.0V conditions above.

Inrush current I_{RUSH}

$$= (\text{Equivalent load capacitance } C_L \times \text{Input voltage } V_{IN} / \text{output rise time } \Delta t) + \text{output load current } I_{LOAD}$$

Generally, during sudden switching, load capacitor is in short mode, and inrush current flows into the capacitor. Of course, if input voltage V_{IN} is large, this current will also increase. As time passes, the load capacitor will be charged and the voltage resulting from this will reduce difference between output and input and the flow of current will saturate. As load capacitance increases the time to saturation increases and thus increase in inrush current. Measurements are taken at $R_L=500\Omega$ which is the worst condition, as when R_L is smaller (output current I_{OUT} is larger) the time to charge is lesser and thus inrush current is reduced.

The turn on time for output V_{OUT} is t_{ON} is also dependent on load capacitance and input voltage. As load capacitance is larger, turn on time gets slower, as is it gets smaller, this time will get faster. As input voltage gets larger, the charging time gets faster and so turn on time also gets faster.

Input voltage, load capacitance dependent inrush current data and the output turn on time is shown in Fig.17 and Fig.18.

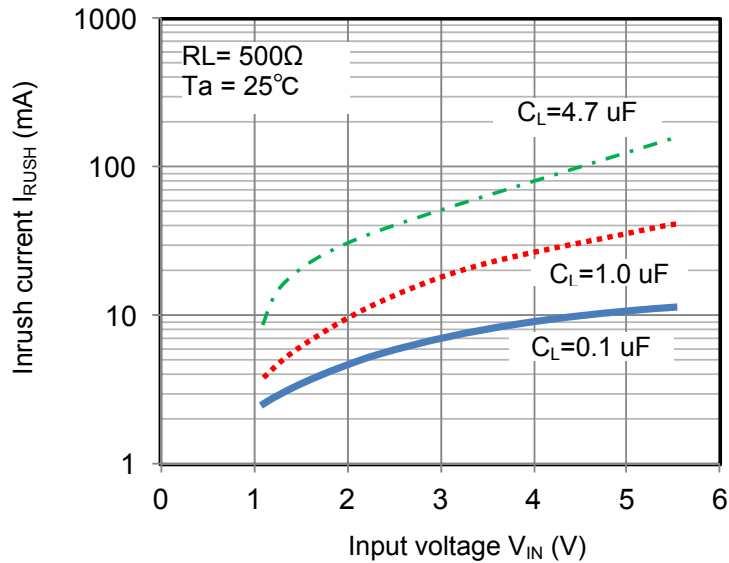

Fig.17 TCK101G inrush current reference data

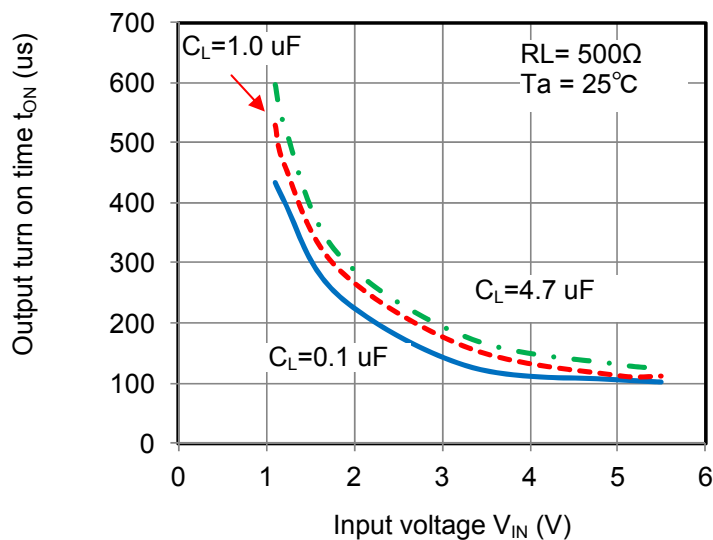

Fig.18 TCK101G Output turn on time reference data

- Usage considerations

- 1) Input capacitor C_{IN}

For TCK10xG operation guarantee, an input capacitor C_{IN} is not necessary. However, to improve the stability of the power supply and to prevent voltage from sudden change in output current, the use of C_{IN} is recommended. For stability, it is recommended that C_{IN} be placed close to V_{IN} . Also, depending on C_{IN} used, $V_{IN} < V_{OUT}$ may occur resulting in reverse current flowing from V_{OUT} to V_{IN} via the parasitic diode of the p-ch MOSFET within the IC. As such, C_{IN} should be selected such that it is larger than C_L .

- 2) Output capacitor

For TCK10xG operation guarantee, an input capacitor C_{OUT} is not necessary. However, depending on output capacitor selected, output transient voltage response, PCB layout and IC internal parasitics can result in overshoot and undershoot. As such, an output capacitor above 0.1 μ F is recommended.

- 3) Heat dissipation design

The power dissipation of load-switch IC and chip junction temperature T_J can be calculated as shown below.

Power dissipation $P_D =$ On resistance $R_{ON} \times$ Output current I_{OUT}^2

Junction temperature $T_J = P_D \times$ Saturation thermal resistance $R_{th}(ja) +$ Ambient temperature T_a

From this equation, it becomes clear that as on resistance R_{ON} gets larger, and the device is used to larger currents, the power dissipation will increase, and as a result the junction temperature will also increase. This in turn will result in higher in an increase in on resistance and consumption current. Depending on the heat dissipation design, there might be a need to increase the size of the GND pattern. Also, depending on the actual voltage and current used during operation, derating should be applied to the specified temperature range and maximum allowed power dissipation on the datasheets, and safety margin for heat dissipation design is necessary,

RESTRICTIONS ON PRODUCT USE

- Toshiba Corporation, and its subsidiaries and affiliates (collectively "TOSHIBA"), reserve the right to make changes to the information in this document, and related hardware, software and systems (collectively "Product") without notice.
- This document and any information herein may not be reproduced without prior written permission from TOSHIBA. Even with TOSHIBA's written permission, reproduction is permissible only if reproduction is without alteration/omission.
- Though TOSHIBA works continually to improve Product's quality and reliability, Product can malfunction or fail. Customers are responsible for complying with safety standards and for providing adequate designs and safeguards for their hardware, software and systems which minimize risk and avoid situations in which a malfunction or failure of Product could cause loss of human life, bodily injury or damage to property, including data loss or corruption. Before creating and producing designs and using, customers must also refer to and comply with (a) the latest versions of all relevant TOSHIBA information, including without limitation, this document, the specifications, the data sheets and application notes for Product and the precautions and conditions set forth in the "TOSHIBA Semiconductor Reliability Handbook" and (b) the instructions for the application that Product will be used with or for. Customers are solely responsible for all aspects of their own product design or applications, including but not limited to (a) determining the appropriateness of the use of this Product in such design or applications; (b) evaluating and determining the applicability of any information contained in this document, or in charts, diagrams, programs, algorithms, sample application circuits, or any other referenced documents; and (c) validating all operating parameters for such designs and applications. **TOSHIBA ASSUMES NO LIABILITY FOR CUSTOMERS' PRODUCT DESIGN OR APPLICATIONS.**
- Product is intended for use in general electronics applications (e.g., computers, personal equipment, office equipment, measuring equipment, industrial robots and home electronics appliances) or for specific applications as expressly stated in this document. Product is neither intended nor warranted for use in equipment or systems that require extraordinarily high levels of quality and/or reliability and/or a malfunction or failure of which may cause loss of human life, bodily injury, serious property damage or serious public impact ("Unintended Use"). Unintended Use includes, without limitation, equipment used in nuclear facilities, equipment used in the aerospace industry, medical equipment, equipment used for automobiles, trains, ships and other transportation, traffic signaling equipment, equipment used to control combustions or explosions, safety devices, elevators and escalators, devices related to electric power, and equipment used in finance-related fields. Do not use Product for Unintended Use unless specifically permitted in this document.
- Do not disassemble, analyze, reverse-engineer, alter, modify, translate or copy Product, whether in whole or in part.
- Product shall not be used for or incorporated into any products or systems whose manufacture, use, or sale is prohibited under any applicable laws or regulations.
- The information contained herein is presented only as guidance for Product use. No responsibility is assumed by TOSHIBA for any infringement of patents or any other intellectual property rights of third parties that may result from the use of Product. No license to any intellectual property right is granted by this document, whether express or implied, by estoppel or otherwise.
- **ABSENT A WRITTEN SIGNED AGREEMENT, EXCEPT AS PROVIDED IN THE RELEVANT TERMS AND CONDITIONS OF SALE FOR PRODUCT, AND TO THE MAXIMUM EXTENT ALLOWABLE BY LAW, TOSHIBA (1) ASSUMES NO LIABILITY WHATSOEVER, INCLUDING WITHOUT LIMITATION, INDIRECT, CONSEQUENTIAL, SPECIAL, OR INCIDENTAL DAMAGES OR LOSS, INCLUDING WITHOUT LIMITATION, LOSS OF PROFITS, LOSS OF OPPORTUNITIES, BUSINESS INTERRUPTION AND LOSS OF DATA, AND (2) DISCLAIMS ANY AND ALL EXPRESS OR IMPLIED WARRANTIES AND CONDITIONS RELATED TO SALE, USE OF PRODUCT, OR INFORMATION, INCLUDING WARRANTIES OR CONDITIONS OF MERCHANTABILITY, FITNESS FOR A PARTICULAR PURPOSE, ACCURACY OF INFORMATION, OR NONINFRINGEMENT.**
- Do not use or otherwise make available Product or related software or technology for any military purposes, including without limitation, for the design, development, use, stockpiling or manufacturing of nuclear, chemical, or biological weapons or missile technology products (mass destruction weapons). Product and related software and technology may be controlled under the Japanese Foreign Exchange and Foreign Trade Law and the U.S. Export Administration Regulations. Export and re-export of Product or related software or technology are strictly prohibited except in compliance with all applicable export laws and regulations.
- Please contact your TOSHIBA sales representative for details as to environmental matters such as the RoHS compatibility of Product. Please use Product in compliance with all applicable laws and regulations that regulate the inclusion or use of controlled substances, including without limitation, the EU RoHS Directive. TOSHIBA assumes no liability for damages or losses occurring as a result of noncompliance with applicable laws and regulations.