

TB67H452FTG

PWM Chopper Type 4 ch H-bridge Motor Driver

The TB67H452FTG is a PWM chopper type 4 ch H-bridge motor driver.

The TB67H452FTG can drive two steppers, two DC brushed motors and one stepping motor, etc. by combining 4 ch H-bridges. And it can also drive dual DC brushed motors or stepping motors for large-current drive by setting Large mode. Moreover, VM power supply voltage can be used 6.3 V or more. Therefore, it is optimal for battery powered applications with 7.2 V power supply for example.

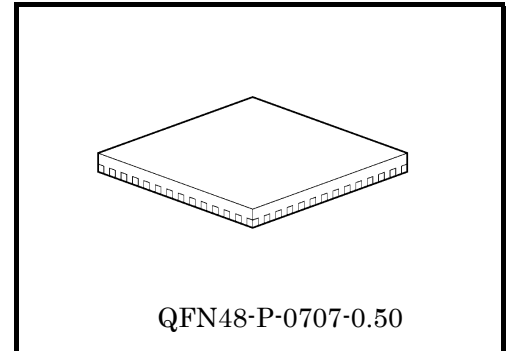

QFN48-P-0707-0.50
Weight: 0.137 g (typ.)

Features

- Single-chip brushed DC motor driver for up to 4 motors
- Single-chip bipolar stepping motor driver for up to 2 motors
- Monolithic IC structured by CD process
- Low ON-resistance: $R_{on} = 0.6 \Omega$
In Large mode, H-bridges can be combined. ON-resistance (R_{on}) = 0.3Ω .
- Over-current detection (ISD), thermal shutdown (TSD), and VM power-on reset circuits
- Since the IC incorporates a VCC regulator for internal circuit operation, an external logic power supply (5 V) is not required
- Package: QFN48
- Maximum output withstand voltage: 40 V (max)
- Output current: 3.5 A (peak) in DC Motor (S) mode
- Chopping frequency can be set by external capacitor and resistor
High-speed chopping is possible at 100 kHz or more

Block Diagram (Brushed DC motor (S) × 4-ch mode)

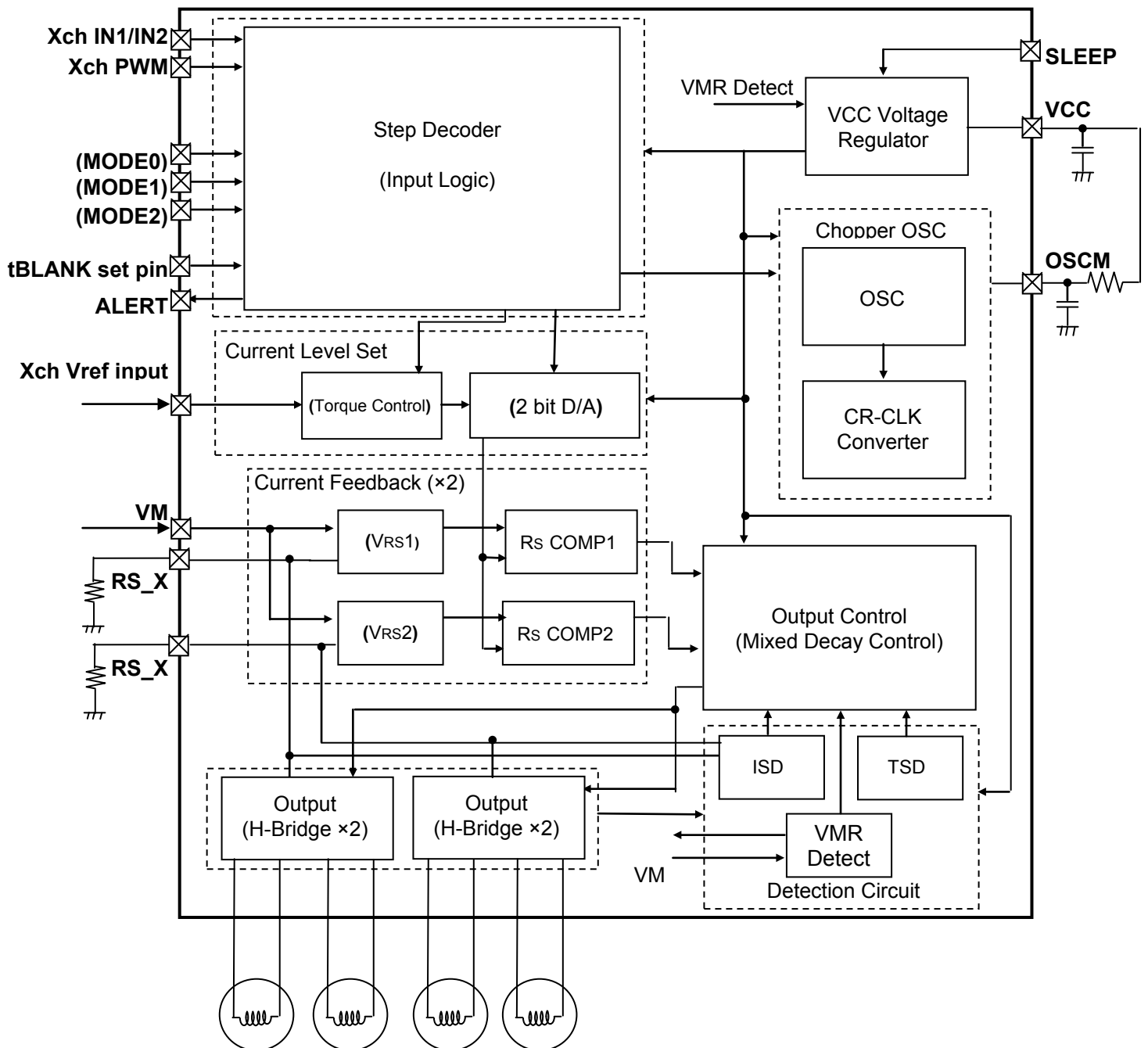

Note: Though pin functions are different depending on the used mode, they are indicated according to the DC(S) ×4 mode in this document.

Note: "X" means the ellipsis of A, B, C, or D of each Ch. (Xch IN1/IN2, Xch PWM, Xch Vref input, and RS_X)

Note: Number of RS pins is 8 in total.

Note: GND wiring: All the grounding wires of the TB67H452FTG should run on the solder mask on the PCB and be externally terminated at only one point. Also, a grounding method should be considered for efficient heat dissipation.

In controlling the setting pins for each mode by SW, those pins should be pulled up to power supply like VCC or pulled down to GND not to go into a high-impedance (Hi-Z) state.

Careful attention should be paid to the layout of the output, VM and GND traces, to avoid short circuits across output pins or to the power supply or ground. If such a short circuit occurs, the device may be permanently damaged.

Also, the utmost care should be taken for pattern designing and implementation of the device since it has power supply pins (VM, RS, OUT, GND, etc.) through which a

particularly large current may run. If these pins are wired incorrectly, an operation error may occur or the device may be destroyed.

The logic input pins must also be wired correctly. Otherwise, the device may be damaged owing to a current running through the IC that is larger than the specified current. Careful attention should be paid to design patterns and mountings.

Pin Assignment

PIN No.	Pin name	(1) Stepper(S)×2	(2) DC(L)×2	(3) Stepper(L)	(4) DC(S)×4	(5) DC(L)+Stepper(S)	(6) DC(S)×2 + Stepper(S)
1	MO_CD	CDch MO pin	CDch IN 1 Pin	-	Cch IN 1 pin	CDch MO pin	
2	CD_MODE2	CDch step resolution mode setting	-	-	Dch IN 2 pin	CDch step resolution mode setting	
3	OUT_C-	Cch output pin(-)	CDch output pin(-)	-	-	Cch output pin(-)	
4	RS_C	Cch sensing Rs connection pin	CDch sensing Rs Connection pin	-	-	Cch sensing Rs connection pin	
5	RS_C	Cch sensing Rs connection pin	CDch sensing Rs Connection pin	-	-	Cch sensing Rs connection pin	
6	OUT_C+	Cch output pin(+)	CDch output pin(+)	-	-	Cch output pin(+)	
7	OUT_D+	Dch output pin(+)	CDch output pin(+)	-	-	Dch output pin(+)	
8	RS_D	Dch sensing Rs connection pin	CDch sensing Rs Connection pin	-	-	Dch sensing Rs connection pin	
9	RS_D	Dch sensing Rs connection pin	CDch sensing Rs Connection pin	-	-	Dch sensing Rs connection pin	
10	OUT_D-	Dch output pin(-)	CDch output pin(-)	-	-	Dch output pin(-)	
11	CD_MODE1	CDch step resolution mode setting	-	-	Dch IN 1 pin	CDch step resolution mode setting	
12	VREF_A	Ach Vref input	ABch Vref input	-	Ach Vref input	ABch Vref input	Ach Vref input
13	VREF_B	Bch Vref input	-	-	Bch Vref input	-	Bch Vref input
14	VREF_C	Cch Vref input	CDch Vref input	-	Cch Vref input	Cch Vref input	Cch Vref input
15	VREF_D	Dch Vref input	-	-	Dch Vref input	Dch Vref input	Dch Vref input
16	OSCM	Setting pin of oscillation circuit frequency for chopping					
17	VCC	Monitoring pin for internal generated 5V bias					
18	GND	GND					
19	VM	VM power input pin					
20	VM	VM power input pin					
21	SLEEP	Sleep pin					
22	ALERT	Alert pin					
23	CLK_AB	ABch CLK input	ABch PWM pin	CLK input	Ach PWM pin	ABch PWM pin	Ach PWM pin
24	ENABLE_AB	ABch ENABLE input	-	ENABLE input	Bch PWM pin	-	Bch PWM pin
25	CLK_CD	CDch CLK input	CDch PWM pin	-	Cch PWM pin	CDch CLK input	CDch CLK input
26	ENABLE_CD	CDch ENABLE input	-	-	Dch PWM pin	CDch ENABLE input	CDch ENABLE input
27	OUT_A-	Ach output pin(-)	ABch output pin(-)	-	Ach output pin(-)	ABch output pin(-)	Ach output pin(-)
28	RS_A	Ach sensing Rs connection pin	ABch sensing Rs connection pin	-	Ach sensing Rs connection pin	ABch sensing Rs connection pin	Ach sensing Rs connection pin
29	RS_A	Ach sensing Rs connection pin	ABch sensing Rs connection pin	-	Ach sensing Rs connection pin	ABch sensing Rs connection pin	Ach sensing Rs connection pin
30	OUT_A+	Ach output pin(+)	ABch output pin(+)	-	Ach output pin(+)	ABch output pin(+)	Ach output pin(+)
31	OUT_B+	Bch output pin(+)	ABch output pin(+)	-	Bch output pin(+)	ABch output pin(+)	Bch output pin(+)
32	RS_B	Bch sensing Rs connection pin	ABch sensing Rs connection pin	-	Bch sensing Rs connection pin	ABch sensing Rs connection pin	Bch sensing Rs connection pin
33	RS_B	Bch sensing Rs connection pin	ABch sensing Rs connection pin	-	Bch sensing Rs connection pin	ABch sensing Rs connection pin	Bch sensing Rs connection pin
34	OUT_B-	Bch output pin(-)	ABch output pin(-)	-	Bch output pin(-)	ABch output pin(-)	Bch output pin(-)
35	D_tBLANK_AB	ABch Decay setting pin	tBLANK setting pin	-	tBLANK setting pin	tBLANK setting pin	tBLANK setting pin
36	NC	NC					
37	D_tBLANK_CD	CDch Decay setting pin	tBLANK setting pin	CDch Decay setting pin	tBLANK setting pin	CDch Decay setting pin	
38	MODE2	"H" input fixed	"H" input fixed	"H" input fixed	"H" input fixed	"L" input fixed	"L" input fixed
39	MODE1	"H" input fixed	"H" input fixed	"L" input fixed	"L" input fixed	"H" input fixed	"H" input fixed
40	MODE0	"H" input fixed	"L" input fixed	"H" input fixed	"L" input fixed	"H" input fixed	"L" input fixed
41	VM	VM power input pin					
42	VM	VM power input pin					
43	NC	NC					
44	CW_CCW_AB	ABch CW/CCW pin	ABch IN2 pin	CW/CCW pin	Ach IN2 pin	ABch IN2 pin	Ach IN2 pin
45	MO_AB	ABch MO pin	ABch IN1 pin	MO pin	Ach IN1 pin	ABch IN1 pin	Ach IN1 pin
46	AB_MODE2	ABch step resolution mode setting	-	Mode setting	Bch IN2 pin	-	Bch IN2 pin
47	AB_MODE1	ABch step resolution mode setting	-	Mode setting	Bch IN1 pin	-	Bch IN1 pin
48	CW_CCW_CD	CDch CW/CCW pin	CDch IN2 pin	-	Cch IN2 pin	CDch CW/CCW pin	

Note: In Large mode, please connect the corresponding pins to each other.

■Descriptions of Motor Drive Modes

- (1) Stepping Motor (S) × 2 ch mode
- (2) DC Motor (L) × 2 ch mode
- (3) Stepping Motor (L) × 1 ch mode
- (4) DC Motor (S) × 4 ch mode
- (5) Stepping Motor (S) × 1 ch mode + DC Motor (L) × 1 ch mode
- (6) Stepping Motor (S) × 1 ch mode + DC Motor (S) × 2 ch mode

Note: (L): Large mode (Large), (S): Small mode (Small).

Note: The digital tBLANK time of the modes including DC Motor (S) mode can be separately set for each ch pair, A and B ch and C and D ch.

A and B ch: D_tBLANK_AB pin

C and D ch: D_tBLANK_CD pin

MODE (2, 1, 0) = (L, L, H) is provided only for Toshiba testing and must not be used during normal operation.

Note: In Combination mode, such as Stepping Motor (L) and DC Motor (L) modes, the impedance outside the IC should be balanced.

Note: In Large mode (Stepping Motor (L) or DC Motor (L)), outputs should be short circuit. If the wiring impedance for each output transistor is different, the current that flows through each output transistor becomes unbalanced and the current may exceed the absolute maximum rating of the transistor. In this case, the IC may break down.

■H-bridge Combination (connection method) for Each Type of Motor Driver

●DC Motor (S) Combination

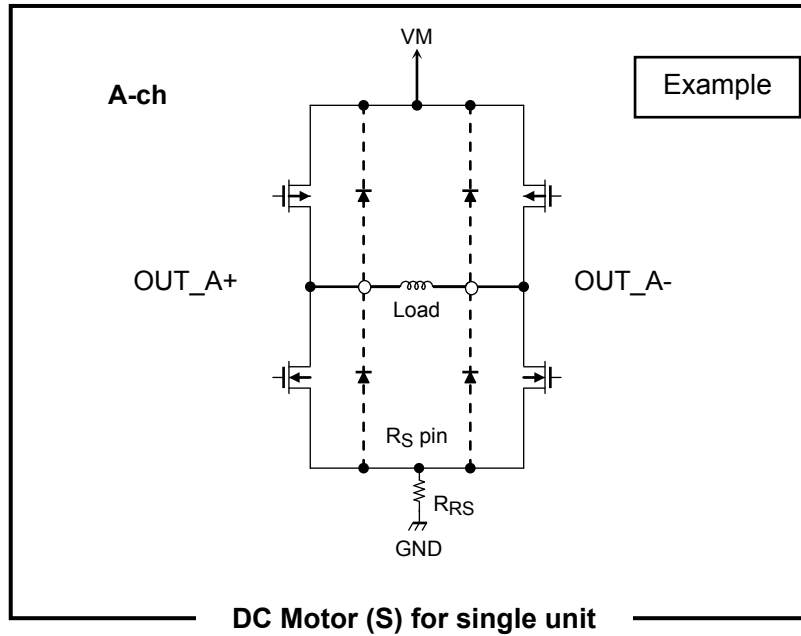

○ ...Motor output pin of the IC

●Stepping Motor(S) Combination

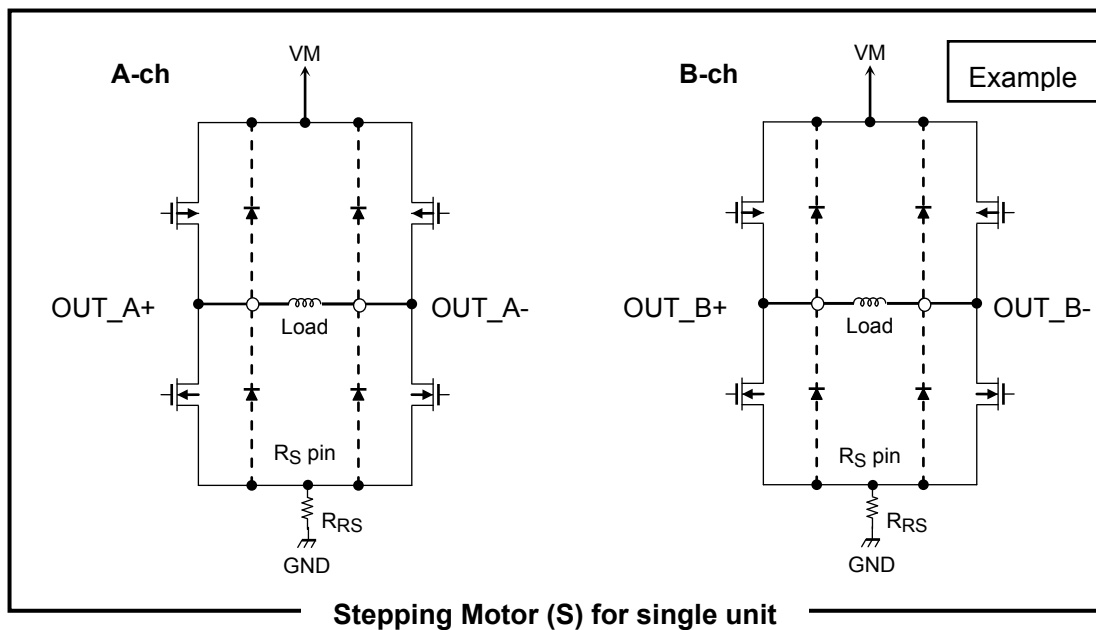

•Stepping Motor(L) Combination

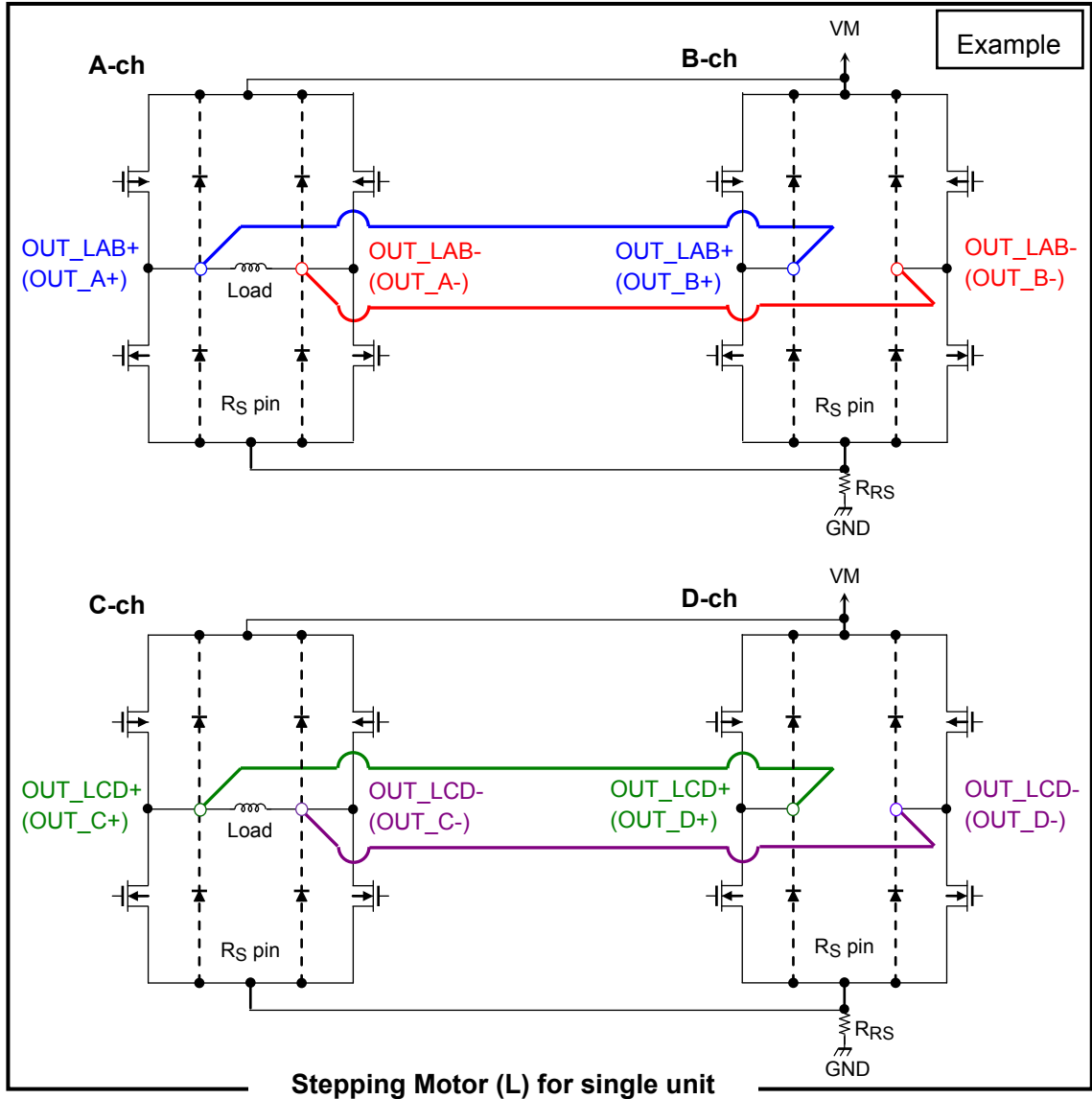

●DC Motor (L) Combination

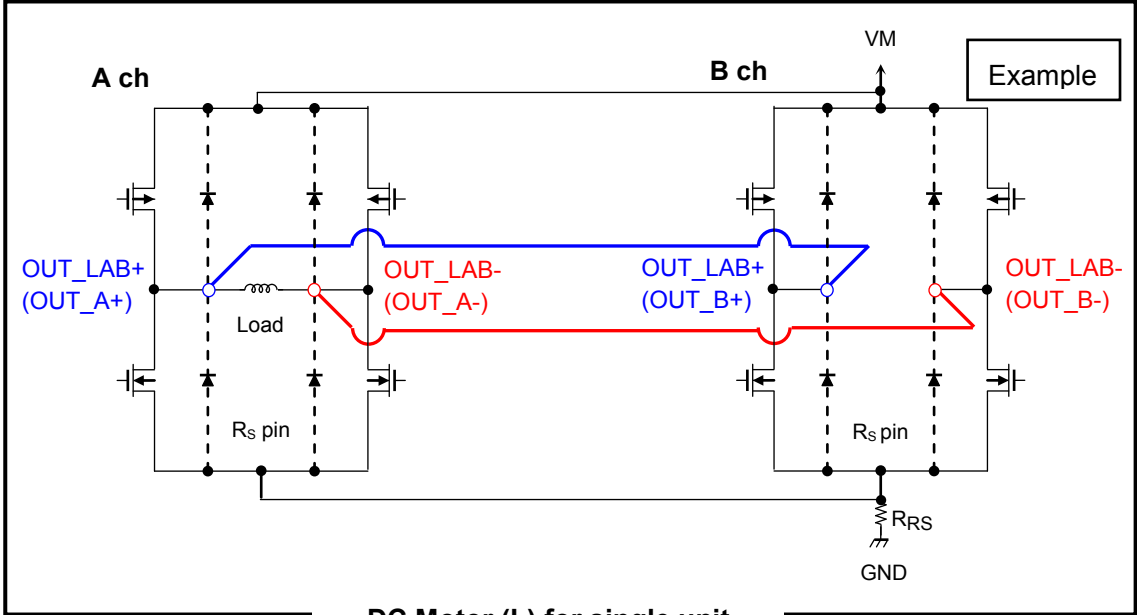

DC Motor (L) for single unit

○...Motor output pin of the IC

Output Control Circuit, Current Feedback Circuit, and Current Setting Circuit for Motor Driver

Note: Logic input pins are internally connected to pull-down resistors of about 100 kΩ.

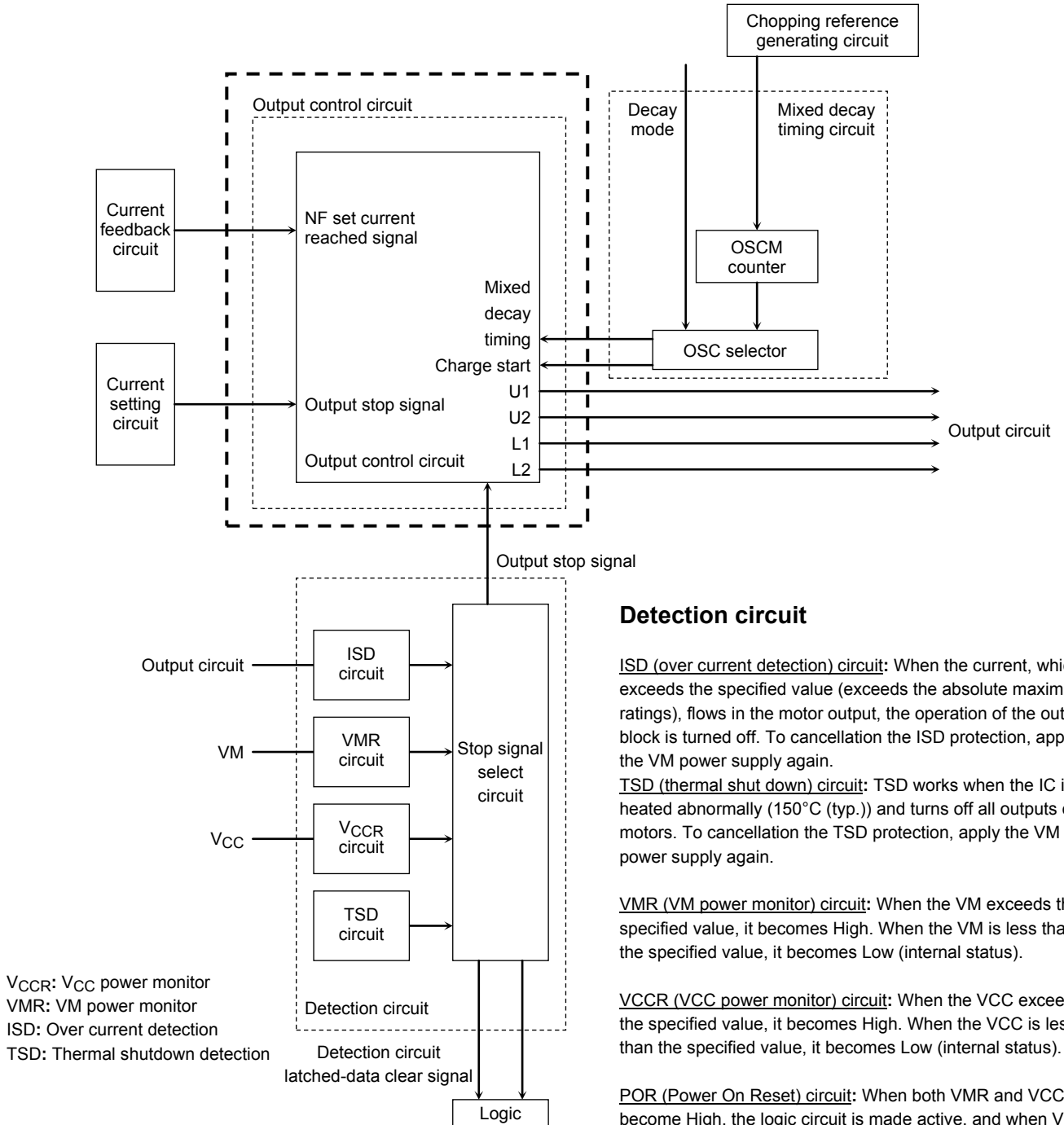

Detection circuit

ISD (over current detection) circuit: When the current, which exceeds the specified value (exceeds the absolute maximum ratings), flows in the motor output, the operation of the output block is turned off. To cancellation the ISD protection, apply the VM power supply again.

TSD (thermal shut down) circuit: TSD works when the IC is heated abnormally (150°C (typ.)) and turns off all outputs of motors. To cancellation the TSD protection, apply the VM power supply again.

VMR (VM power monitor) circuit: When the VM exceeds the specified value, it becomes High. When the VM is less than the specified value, it becomes Low (internal status).

VCCR (VCC power monitor) circuit: When the VCC exceeds the specified value, it becomes High. When the VCC is less than the specified value, it becomes Low (internal status).

POR (Power On Reset) circuit: When both VMR and VCCR become High, the logic circuit is made active, and when VMR and VCCR become other than High, the logic circuit is made stop.

Output Equivalent Circuit of A/B-unit (C/D-unit is same as A/B-unit.)

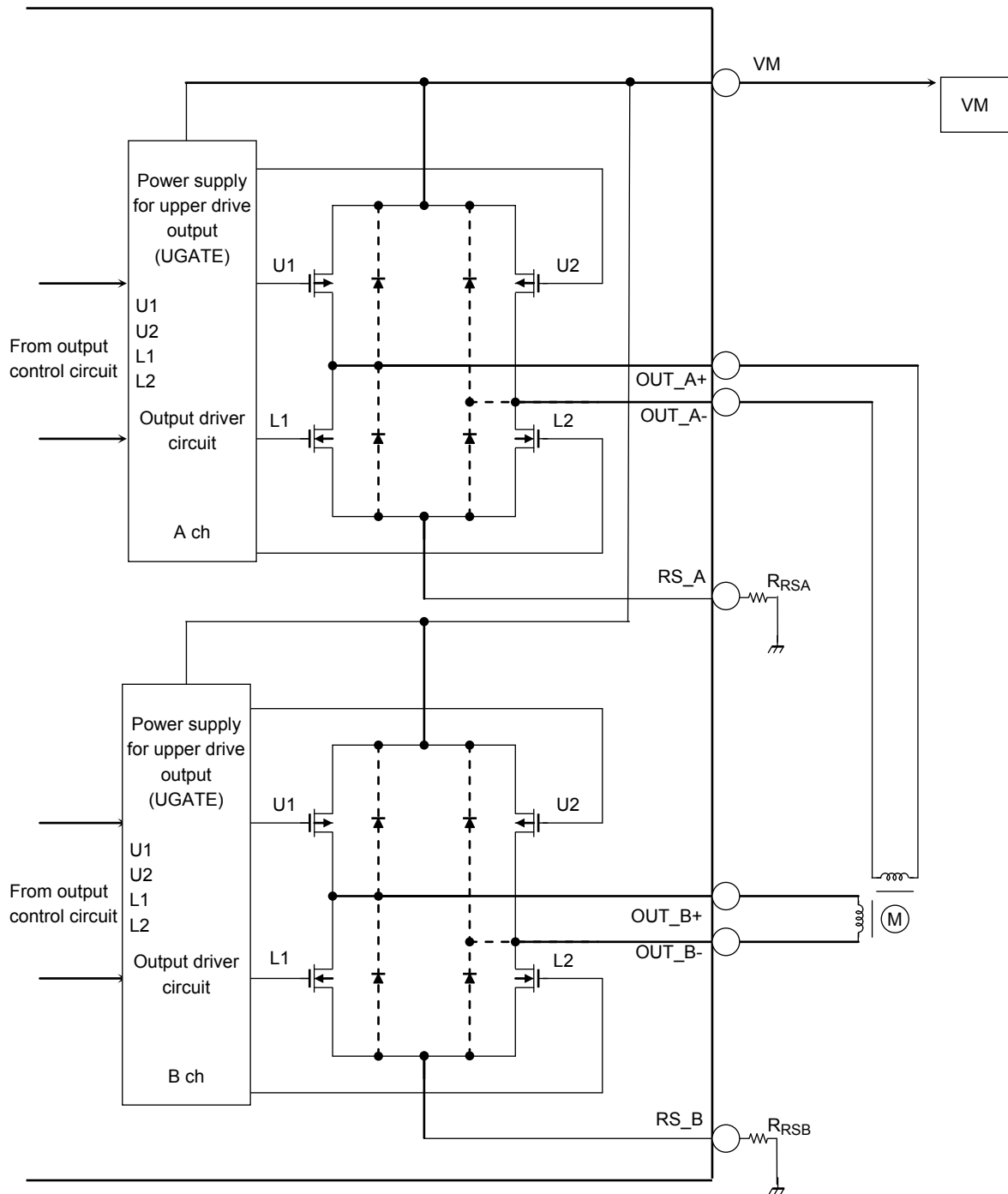

1. Function of Motor Drive Mode Selection

Motor drive modes can be selected depending on the type of motors.

The configuration of H-bridge drivers and control category are changed according to the selected mode.

Basically, driving mode will not be changed during operation. Thus, the TB67H452FTG does not support dynamic mode switching.

When configurations of these pins are changed, the functions and timing of control pins are changed.

The combination of mode select pins must not be changed after the TB67H452FTG is powered on.

MODE0 pin	MODE1 pin	MODE2 pin	Motor Drive Mode
H	H	H	Stepping Motor (S) × 2
L	H	H	DC Motor (L) (Combination) × 2
H	L	H	Stepping Motor (L) (Combination) × 1
L	L	H	DC Motor (S) × 4
H	H	L	DC Motor (L) (Combination) × 1 + Stepping Motor (S)
L	H	L	DC Motor (S) × 2 + Stepping Motor (S)
H	L	L	Inhibited (For Toshiba testing only)
L	L	L	Standby mode

- **Brushed DC Motor Mode (DC Motor (L or S))**

This mode is used to drive brushed DC motors.

The tBLANK can be switched a fixed analog value, or the digital tBLANK mode in which the blanking time is 4 CLK of the chopping reference OSC frequency.

When DC motors are driven under PWM control, a discharge current spike can be generated due to a varistor. To prevent this current spike from erroneously tripping the constant-current detection, the constant-current detection is digitally blanked for a period of time that is determined by tBLANK. Digital tBLANK time is based on the OSC signal.

Using this blanking function enables constant-current limiter control, as well as external PWM control. However, an over-current phenomenon can be observed only during blanking times.

- **Stepping Motor Mode (Stepping Motor (L or S))**

This mode is used to drive stepping motors.

The tBLANK time is specified as a fixed analog value (about 300 ns).

Each motor is controlled via two logic control inputs, PHASE (current direction) and ENABLE (ON/OFF), and via the Vref input for constant-current control.

- **Combination Mode (Large Mode)**

The Combination mode, such as DC Motor (L) and Stepping Motor (L) modes, can be selected when two units of H-bridges with the same characteristics are operated in parallel.

In this mode, the actual ON-resistance is reduced by half while the current capability is doubled. (Specifications actually include the thermal capacitance as well. See electrical characteristics for more details.)

To use this mode, the power supply, ground, and output pins that have identical names should be shorted together on the board.

At the same time, the wirings of a board should be routed to balance the impedance at each pin. Otherwise, the shorted pins may experience a current imbalance and more current may flow into either one of them than the other.

2. Control Signal Functions in Brushed DC Motor Mode

*In DC Motor (S) mode

Control input			State of output stage		
X-ch IN1	X-ch IN2	X- ch PWM pin	OUT_X+	OUT_X-	Mode
H	H	H	L	L	Short brake
		L			
L	H	H	L	H	Forward/Reverse
		L	L	L	Short brake
H	L	H	H	L	Reverse/Forward
		L	L	L	Short brake
L	L	H	OFF (Hi-Z)	OFF (Hi-Z)	Stop
		L			

Note: "X" means the ellipsis of A, B, C, or D of each Ch. (X-ch IN1, X-ch IN2, X-ch PWM pin, OUT_X+, and OUT_X-)

Note: When PWM pin is not used, fix it to high level.

● External PWM Control Function

The motor speed can be controlled by applying 0 V and 5 V (higher than TTL level) PWM signals to the PWM pin.

In PWM mode, the PWM chopper circuit alternates between on and short brake.

When the PWM speed control is not required, the PWM pin (short brake pin) should be held High.

When the constant-current limiter is used, the TB67H452FTG enters 37.5% Mixed Decay mode after an output current reaches the predefined current value. Since the blanking time is internally inserted to prevent a shoot-through current eliminating, a special configuration is not required.

The short brake function is disabled in Stepping Motor mode (Large or Small).

Stepping motors can also be driven in Brushed DC motor mode.

To perform such operation, the short brake function should not be used and the digital tBLANK pin should be set Low.

At the same time, input signal functions should also be confirmed.

3. D_tBLANK Function (DC Motor Mode only)

D_tBLANK_AB D_tBLANK_CD	Motor Drive Mode
L	OFF: Digital Blanking Time = OSC×0
H	ON: Digital Blanking Time = OSC×4

* When it is set to "L", blanking time corresponds to only analog tBLANK width.

4. Signal Control Function in Stepping Motor Mode

(1) CLK Function

The electrical angle leads one by one in the manner of the clocks. The clock signal is reflected to the electrical angle on the rising edge.

CLK_AB CLK_CD	Function
↑	The electrical angle leads one by one on the rising edge
↓	— (keeps former state)

(2) ENABLE Function

The ENABLE pin controls ON and OFF of the current flow for stepping motors. This pin controls whether the motor is stopped in Off mode or activated. It should be fixed to Low at power-on or shut-down of the TB67H452FTG.

ENABLE_AB ENABLE_CD	Function
H	Output transistors are enabled (normal operation mode).
L	Output transistors are disabled (high impedance: Z).

(3) CW/CCW Function and output pin function (Output logic at charge start)

The CW/CCW pin switches rotation direction of stepping motors.

CW_CCW_AB CW_CCW_CD	Input function	OUT_X+ (Note2)	OUT_X- (Note2)
X(Note1)	L	OFF	OFF
H	Clock-wise (CW)	H	L
L	Counter clock-wise (CCW)	L	H

Note1: X: Don't care

Note2: "X" means the ellipsis of A, B, C, or D of each Ch. (OUT_X+, and OUT_X-)

(4) Function of step resolution

AB_MODE1 CD_MODE1	AB_MODE2 CD_MODE2	Function
L	L	Fixed electrical angle (Initial setting of Full step: 45°)
L	H	Half step
H	L	Full step
H	H	Quarter step

In the case of AB/CD_MODE1=L, and AB/CD_MODE2=L, the electrical angle is reset and fixed to 45°, which is the initial value in the full step mode.

5. Decay Switching Function (Stepping Motor only)

D_tBLANK_AB D_tBLANK_CD	Constant current control mode
L	Mixed Decay: 37.5% fixed
H	Mixed Decay: 12.5% (During the current decay: 37.5%)

6. SLEEP Function

The low power consumption mode (VCC OFF) and the normal operation mode (VCC ON) can be controlled by this pin.

When SLEEP pin is Low, VCC regulator is turned OFF, completely logic will stop.

After SLEEP pin is set to High, it can return to the normal operation mode in 1 ms.

SLEEP	Drive Mode
L	Low power consumption mode (VCC OFF)
H	Normal operation mode (VCC ON)

7. ALERT Function

The ALERT pin will output “Low” level when error detection (TSD or ISD) turns off the IC operation.

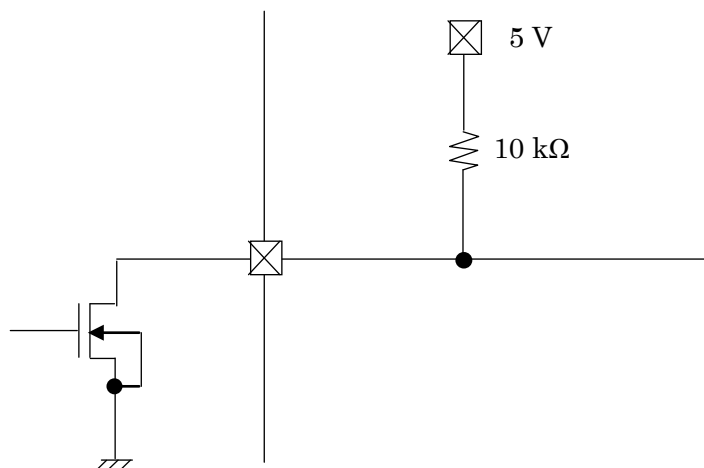

The ALERT pin is an open drain output pin. When the output pin is pulled up to the VCC with a resistor, the Low is outputted (MOSFET ON) at the Reset, and the High (internal Hi-Z) is outputted at the non-reset.

Please connect it to the VCC pin for pull-up.

•Absolute Maximum Ratings (Ta=25°C)

Characteristics	Symbol	Rating	Unit	Remarks
Motor power supply	VM	40	V	—
Motor output voltage	VOUT	40	V	—
Motor output current (Note 1)	IOUT (ST_S)	3.5	A	(tw ≤ 500 ns)
	IOUT (ST_L)	5.0	A	(tw ≤ 500 ns)
	IOUT (DC_S)	3.5	A	(tw ≤ 500 ns)
	IOUT (DC_L)	5.0	A	(tw ≤ 500 ns)
Internal Logic power supply	VCC	6.0	V	—
Logic input voltage	VIN(H)	6.0	V	—
	VIN(L)	-0.4	V	—
Power dissipation (single) (Note 2)	PD	1.3	W	—
Operating temperature	TOPR	-20 to 85	°C	—
Storage temperature	TSTR	-55 to 150	°C	—
Junction temperature	Tj(max)	150	°C	—

Note 1: As a guide, the maximum output current should be kept below 1.4 A per phase. The maximum output current may be further limited in view of thermal considerations, depending on ambient temperature and board conditions.

Note 2: Stand-alone (Ta =25°C)

When Ta exceeds 25°C, it is necessary to do the derating with 10.4 mW/°C.

Ta: Ambient temperature

Topr: Ambient temperature while the TB67H452FTG is active

Tj: Junction temperature while the TB67H452FTG is active. The maximum junction temperature is limited by the thermal shutdown (TSD) circuitry.

It is advisable to keep the maximum current below a certain level so that the maximum junction temperature, Tj (max), will not exceed 120°C.

Caution) Absolute maximum ratings

The absolute maximum ratings of a semiconductor device are a set of ratings that must not be exceeded, even for a moment. Do not exceed any of these ratings.

Exceeding the rating (s) may cause device breakdown, damage or deterioration, and may result in injury by explosion or combustion.

The value of even one parameter of the absolute maximum ratings should not be exceeded under any circumstances. The TB67H452FTG does not have overvoltage detection circuit. Therefore, the device is damaged if a voltage exceeding its rated maximum is applied.

All voltage ratings, including supply voltages, must always be followed. The other notes and considerations described later should also be referred to.

Operating Ranges(Ta=0 to 85°C)

Characteristics	Symbol	Test Circuit	Test Condition	Min	Typ.	Max	Unit
Internal logic power supply voltage	VCC	DC	(Automatically generated)	4.5	5.0	5.5	V
Motor power supply voltage	VM	DC	—	6.3	24	38	V
Motor output current	I _{out} (ST_S)	DC	Ta = 25°C, per phase	—	0.8	1.5	A
	I _{out} (ST_L)	DC	Ta = 25°C, per phase	—	1.5	2.1	
	I _{out} (DC_S)	DC	Ta = 25°C, per phase	—	1.0	2.0	
	I _{out} (DC_L)	DC	Ta = 25°C, per phase	—	2.0	3.8	
Logic input voltage	VIN	DC	—	GND	3.3	5.0	V
Chopping frequency setting range	fchop	DC	VCC=5.0 V	40	100	150	kHz
Vref voltage	Vref	DC	VM=24 V	GND	3.0	4.0	V
Current detect pin voltage	VRS	DC	VM=24 V	0	±1.0	±1.5	V

Note: Use the maximum junction temperature (T_j) at 120°C or less. The maximum current cannot be used under certain thermal conditions.

Electrical Characteristics 1 (Unless otherwise specified, Ta=25°C, VM=24 V)

Characteristics		Symbol	Test Circuit	Test Condition	Min	Typ.	Max	Unit
Logic input voltage (Other than SLEEP pin)	High	VIH	DC	Logic input pins (Other than SLEEP pin)	2.2	—	5.5	V
	Low	VIL			GND	—	0.8	
Logic input voltage (SLEEP pin only)	High	VIH	DC	SLEEP pin only	2.0	—	5.5	V
	Low	VIL			GND	—	0.6	
Logic input hysteresis voltage		His	DC	Logic input pins	0.3	0.4	0.5	V
Logic input current		IIN(H)	DC	VIN=5 V, Input pins with resistor	—	50	75	μA
		IIN(L)			—	—	1	
MO,ALERT output voltage		VOL	DC	IOL=4 mA output: Low	—	—	0.5	V
Current consumption (VM line)		IM1	DC	Output=OPEN (ENABLE ALL=L), MOSFET=OFF	—	2	3	mA
		IM2		Output=OPEN, fPWM=100 kHz Logic operate, MOSFET=OFF	—	3.5	5	
		IM3		Output=OPEN Function mode(Full step)	—	8	10	
		IM4		SLEEP=L VCC regulator = OFF	—	10	20	μA
Output leakage current	Upper side	IOH	DC	VM=24 V, Vout=0 V, ENABLE ALL=L	-1	—	—	μA
	Lower side	IOL		VM=Vout=24 V, ENABLE ALL=L	—	—	1	μA
Output current differential		ΔI_{out1}	DC	Iout=1.0 A	-5	—	5	%
Output current setting differential		ΔI_{out2}	DC	Iout=1.0 A	-5	—	5	%
RS pin current		IRS	DC	VRS=0 V, VM=24 V, ENABLE ALL=L (MOSFET = OFF)	—	—	10	μA
Output transistor drain-source ON-resistance (upper + lower)		Ron (DS: upper + lower) S	DC	Iout=1.0 A, Tj=25°C, Drain-source, (upper + Lower) Small Mode	0.4	0.6	0.8	Ω
		Ron (DS: upper + lower) L		Iout=1.0 A, VCC=5.0 V, Tj=25°C, Drain-source, (upper + Lower) Large Mode	—	0.3	0.4	

Electrical Characteristics 2 (Unless otherwise specified, Ta=25°C, VM=24 V)

Characteristics	Symbol	Test Circuit	Test Condition	Min	Typ.	Max	Unit
Vref input voltage	VREF	DC	VM=24 V, VCC=5 V	GND	3.0	4.0	V
Vref input current	IREF	DC	VREF=3.0 V	—	0	1	μA
VCC output voltage	VCC	DC	ICC=5.0 mA	4.5	5.0	5.5	V
VCC output current	ICC	DC	VCC=5.0 V	—	2.5	5	mA
Vref attenuation ratio	VREF(gain)	DC	VREF=2.0 V	1/5.2	1/5.0	1/4.8	—
TSD temperature (Note 1)	TjTSD	DC	—	140	150	170	°C
VM return voltage	VMR	DC	—	5.5	5.7	6.0	V
Detection current of over-current detection circuit (Note 2)	ISD	DC	—	2.1	4.0	5.0	A

Note 1: Thermal shutdown detection (TSD) circuit

When the IC junction temperature reaches the specified value and becomes overheated, the TSD circuit is activated and the internal reset circuit is activated to turn off all of the outputs.

The TSD circuit operates between 140°C (min) to 170°C (max) (design value). When the TSD circuit is operating, the IC operation can be returned by re-starting the VM power supply or setting the standby mode. The TSD function aims at detecting abnormal heating of ICs. Please avoid positively using the TSD function.

Note 2: Over current detection (ISD) circuit

When the output current exceeds the specified value, the ISD circuit judges it as an abnormal condition and the internal reset circuit is activated to turn off all the outputs. The blanking time is set to avoid the incorrect operation by switching. (For details, refer to “ISD Blanking Time and ISD Operating Time.”) When the ISD function is operating, the output is stopped until power-on-reset of the VM power supply. It can be returned by re-starting the VM power supply or setting the standby mode. The ISD function aims at detecting abnormal current of ICs. Please avoid positively using the ISD function.

Note 3: The internal circuits are designed to avoid EMF or leakage current, when the logic signal is inputted while the VM voltage is not supplied. But for avoid operating the motor at the timing of resupply, please control the logic signal timing correctly before the VM power is resupplied.

Back-EMF

- While a motor is rotating, there is a timing at which power is fed back to the power supply. At that timing, the motor current recirculates back to the power supply due to the effect of the motor back-EMF. If the power supply does not have enough sink capability, the power supply and output pins of the device might rise above the rated voltages. The magnitude of the motor back-EMF varies with usage conditions and motor characteristics. It must be fully verified that there is no risk that the device or other components will be damaged or fail due to the motor back-EMF.

Cautions on Over current detection (ISD) and Thermal shutdown detection (TSD)

- The ISD and TSD circuits are only intended to provide temporary protection against irregular conditions such as an output short-circuits, they do not necessarily guarantee the complete IC safety.
- If the device is used beyond the specified operating ranges, these circuits may not operate properly, then the device may be damaged due to an output short-circuit.
- The ISD circuit is only intended to provide a temporary protection against an output short-circuit. If such condition persists for a long time, the device may be damaged due to overstress. Overcurrent conditions must be removed immediately by external hardware.

IC Mounting

Do not insert devices in the wrong orientation or incorrectly. Otherwise, it may cause device breakdown, damage and/or deterioration.

AC Electrical Characteristics (Ta = 25°C, VM = 24 V, Load = 6.8 mH/5.7Ω)

Characteristics	Symbol	Test Circuit	Test Condition	Min	Typ.	Max	Unit
Logic input frequency	fLogic	AC	—	1.0	—	200	kHz
CLK input internal filter width	tCLK(H)	AC	—	300	—	—	ns
	tCLK(L)			250	—	—	
Output transistor switching characteristic	tr	AC	Output load: 6.8 mH/5.7 Ω	60	120	200	ns
	tf			30	70	130	
	tpLH		Between Signal to OUT Output load: 6.8 mH/5.7 Ω	—	120	500	
	tpHL			—	120	500	
Noise rejection blanking time	tBLANK_AB(L) tBLANK_CD(L)	AC	Iout=0.6 A, VM=24 V, Analog tBLANK width	450	550	700	ns
	tBLANK_AB(H) tBLANK_CD(H)	AC	Iout=0.6 A, OSC=1.6 MHz, 4×OSC setting	2.0	2.5	3.0	μs
OSCM reference signal oscillation frequency	fOSCM	AC	Cosc=270 pF, Rosc=120 kΩ	1200	1600	2000	kHz
Chopping frequency range	fchop	AC	Output operation (Iout=1.0 A)	40	100	150	kHz
Chopping frequency	fchop	AC	Output operation (Iout=1.0 A) OSC=1.6 MHz	—	100	—	kHz

Decay Mode: Charge⇒Slow⇒Fast

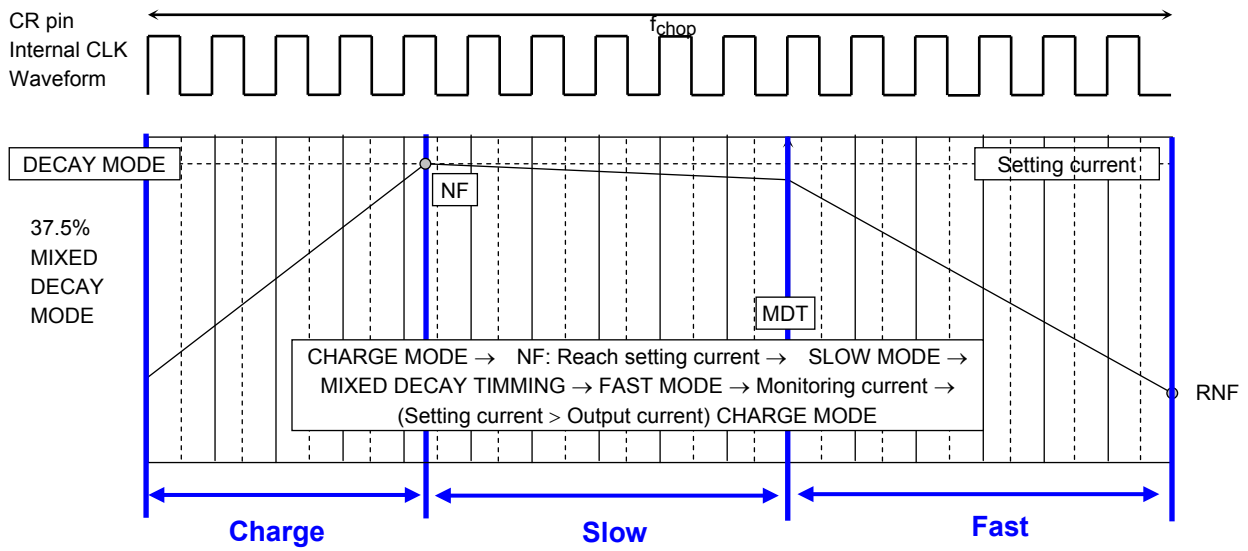

Mixed Decay Mode / Detecting zero point

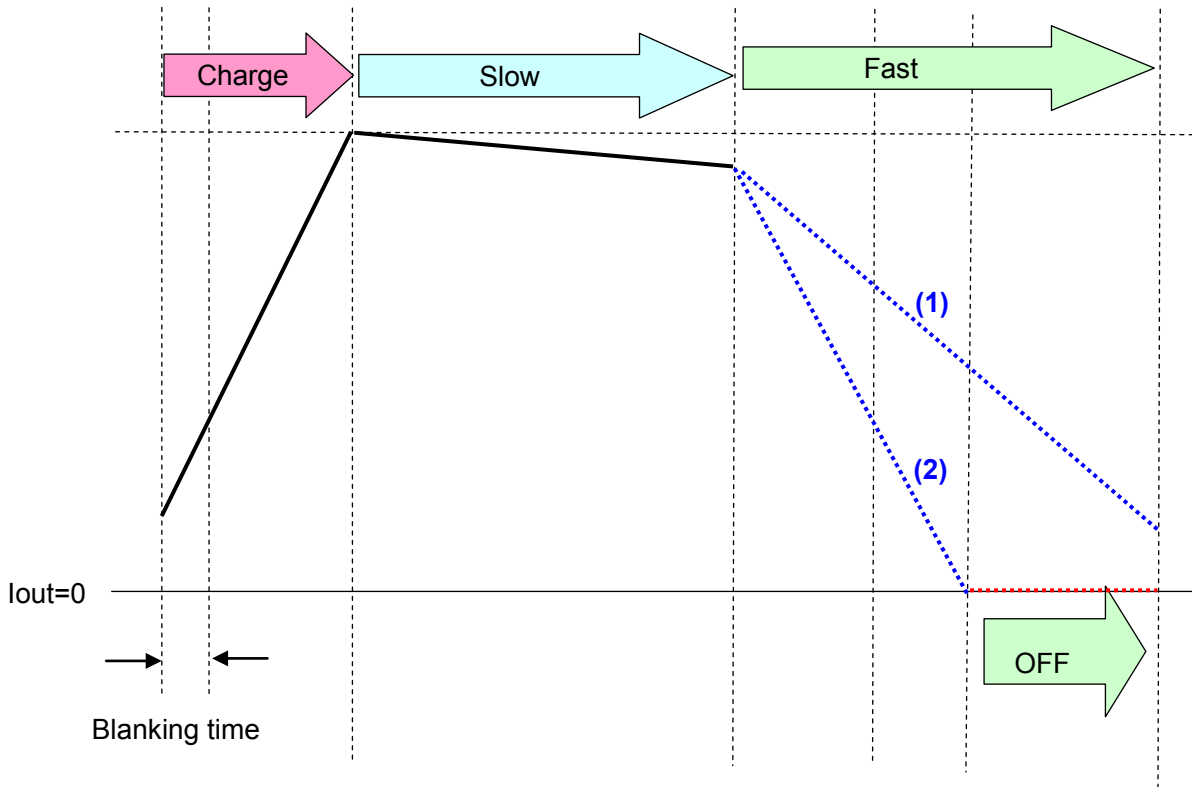
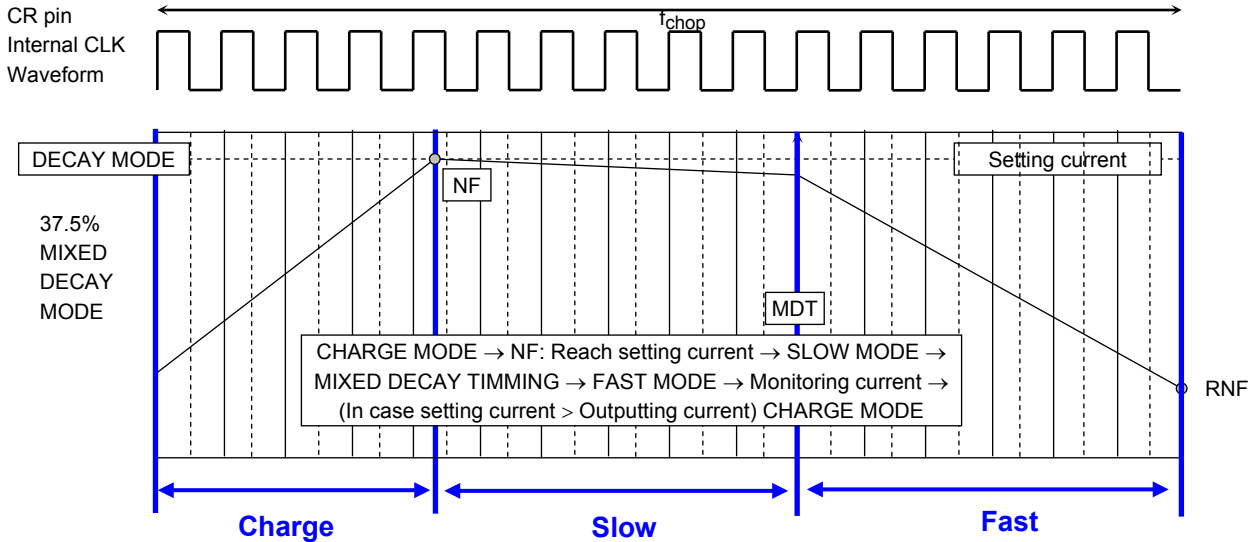

The [NF] shows the point of which the output current reaches the setting current value. The [Charge] shows the different value depending on the step resolution characteristics such as inductance and resistance.

Status (1): When the mode moves from Fast to Charge before reaching zero point ($I_{out}=0$ A)

Status (2): When reaching zero point ($I_{out}=0$ A)

Mixed Decay mode: Charge->NF: Reaching setting current->Slow->Fast->Charge->...

Output Transistor Operating Modes

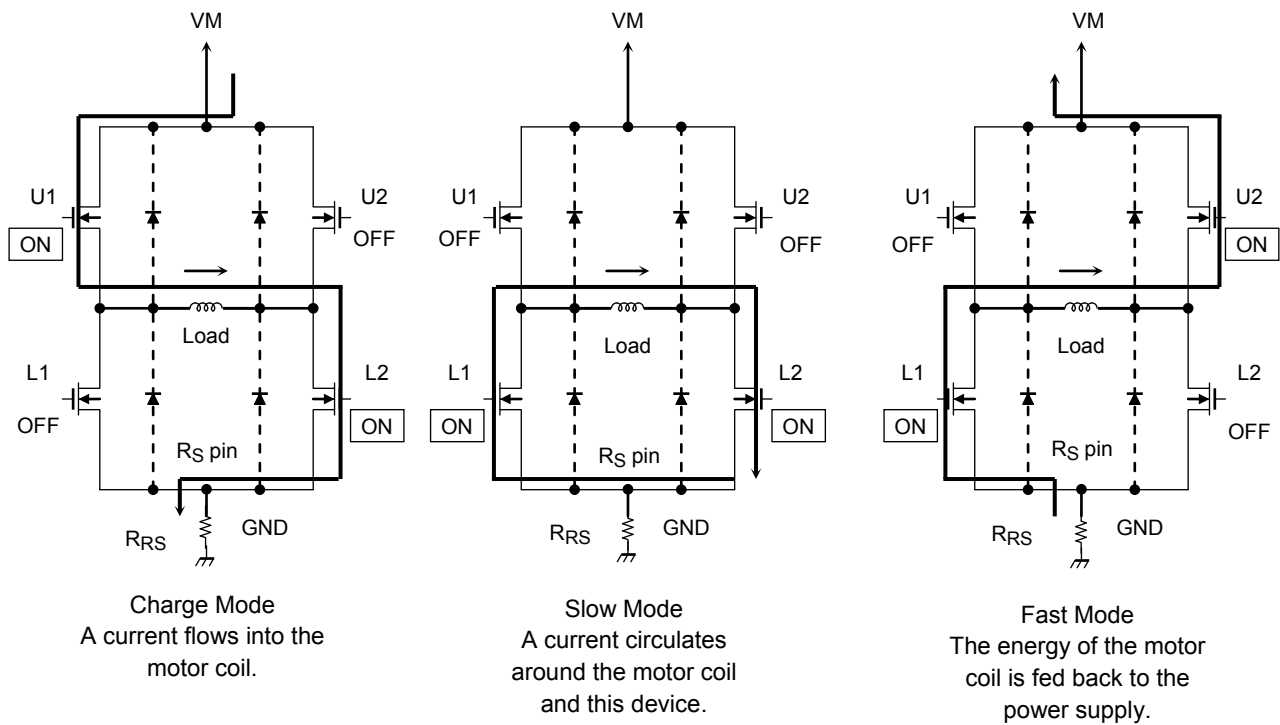

Output Transistor Operating Function

CLK	U1	U2	L1	L2
Charge Mode	ON	OFF	OFF	ON
Slow Mode	OFF	OFF	ON	ON
Fast Mode	OFF	ON	ON	OFF

Note: Above table shows an example of when the current flows as indicated by the arrows in the figures shown above. If the current flows in the opposite direction, refer to the following table.

CLK	U1	U2	L1	L2
Charge Mode	OFF	ON	ON	OFF
Slow Mode	OFF	OFF	ON	ON
Fast Mode	ON	OFF	OFF	ON

The TB67H452FTG switches among Charge, Slow and Fast modes automatically for constant-current control.

The equivalent circuit diagrams may be simplified or some parts of them may be omitted for explanatory purposes.

Calculation of the Setting Output Current

For PWM constant-current control, the TB67H452FTG uses a clock generated by OSCM oscillator. The peak output current can be set via the current-sensing resistor (R_{RS}) and the reference voltage (V_{ref}), as follows:

$$I_{out} (Max) = V_{ref} (gain) \times \frac{V_{ref} (V)}{R_{RS} (\Omega)}$$

V_{ref} (gain): V_{ref} decay ratio is 1 / 5.0 (typ.).

Ex.: In case of 100% setting,

When V_{ref} = 3.0 V, Torque = 100%, and R_{RS} = 0.51 Ω,

constant current output of the motor (peak current) is calculated as follows;

$$I_{out} = 3.0 V / 5.0 / 0.51 \Omega = 1.18 A.$$

OSCM oscillation frequency

For OSCM oscillation frequency, the frequency can be changed by an external capacitor and resistor.

By changing the frequency of the OSCM, the chopping frequency can be changed.

Please adjust the chopping frequency by referring to the following table.

Chopping [kHz]	C [pF]	R [kΩ]
150	150	180
140	180	100
130	180	150
120	220	100
110	180	220
100	270	120
90	330	68
80	330	130
70	390	130
60	470	120
50	560	180
40	820	68

PD – Ta (Package Power Dissipation)

PD – Ta

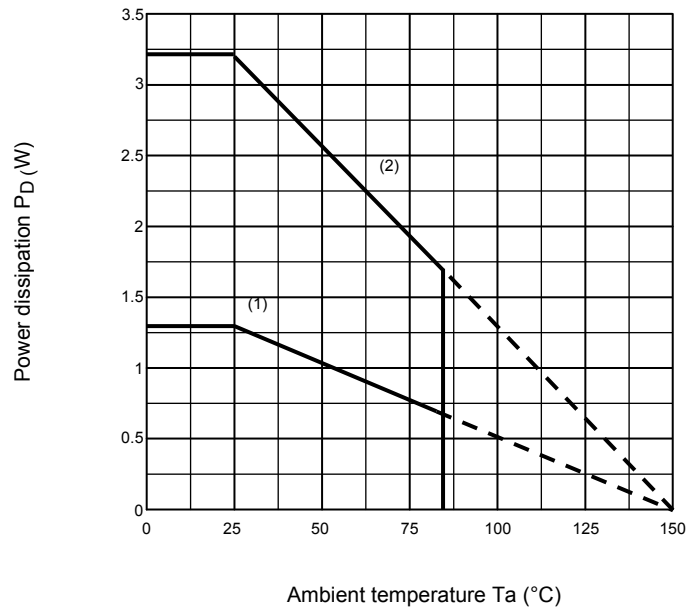

- (1) Stand-alone: $R_{th(j-a)}$: 113°C/W
- (2) When mounted on the board
(size: 100 mm×200 mm×1.6 mm, 2-layer board :37°C/W (typ.))

Operating Time for Over-current Detection Circuit

ISD Blanking Time and ISD Operating Time

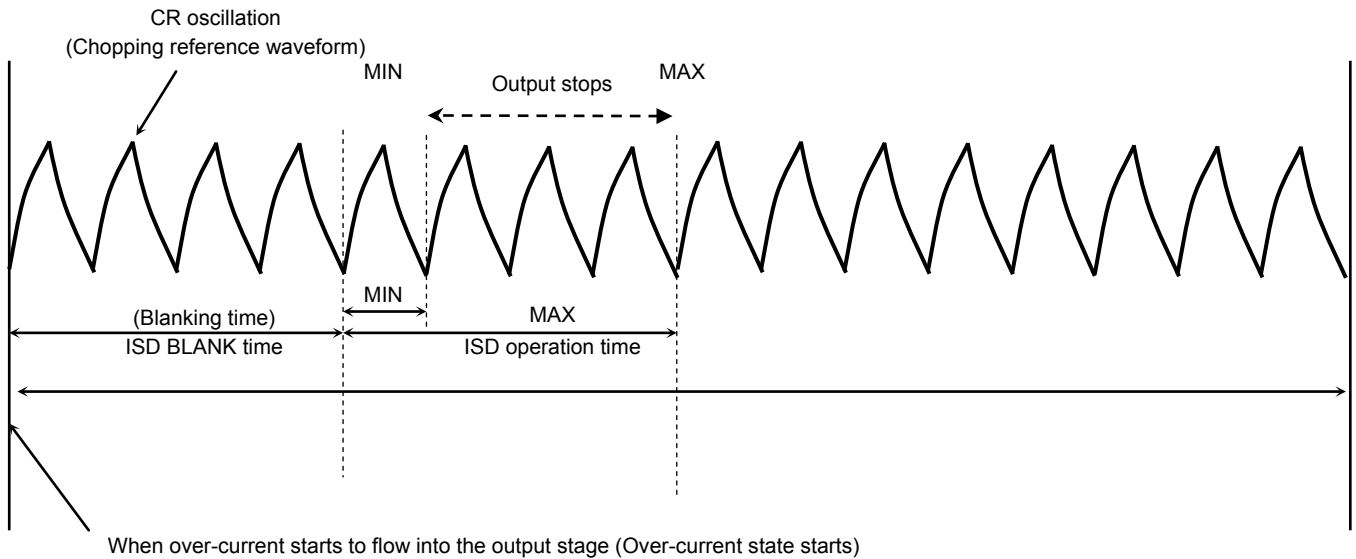

The over-current detection circuit has a blanking time to prevent erroneous detection of I_{RR} or spike current at switching. The blanking time, which is synchronized with the frequency of the OSC for setting chopping frequency, is calculated as follows.

$$\text{Blanking time} = 4 \times \text{CR cycle}$$

Time required to stop the output after over-current flows into the output stage is calculated as follows.

$$\text{Minimum time: } 4 \times \text{CR time}$$

$$\text{Maximum time: } 8 \times \text{CR time}$$

Note that the above-mentioned operating times are achieved only when over-current flows as it is expected. Depending on the timing of output control mode, the circuit may not be triggered.

Thus, to ensure safe operation, please insert a fuse in the VM power supply.

The capacity of the fuse is determined according to the usage conditions. Please select appropriate fuse whose capacity does not exceed the power dissipation of the IC.

● **tBLANK (noise rejection blanking time)**

The TB67H452FTG has two different blanking times in accordance with different motors so as to prevent noise malfunctions in switching.

(1) Analog tBLANK Functions (in Stepping Motor Mode)

The noise rejection blanking time (analog tBLANK) defined by the AC characteristics of the motor is fixed in the IC. It is mainly used to avoid misjudging the I_{RR} (diode recovery current) when a stepping motor is driven with constant current.

It cannot be changed because it is the fixed value of the IC.

(2) Digital tBLANK (in Brushed DC Motor mode)

Apart from the analog tBLANK which is set by the initial mode selection, the digital tBLANK time is created digitally from an external chopping period. This blanking time is used to prevent false detections of a varistor recovery current generated during PWM operation of DC motors in DC Motor mode.

When stepping Motor mode is selected by the mode select pins, the digital tBLANK time is nullified (0 μs) and the analog tBLANK time, which is internally fixed, becomes effective.

Since this blanking time is created based on the OSCM signal, the time can be adjusted by changing the OSCM signal frequency.

(Please note that the characteristics other than the blanking time, such as motor chopping frequency and the blanking time inserted at power on are also changed when the OSCM signal frequency is changed.)

● **Digital tBLANK Insertion Timing in Brushed DC Motor Mode**

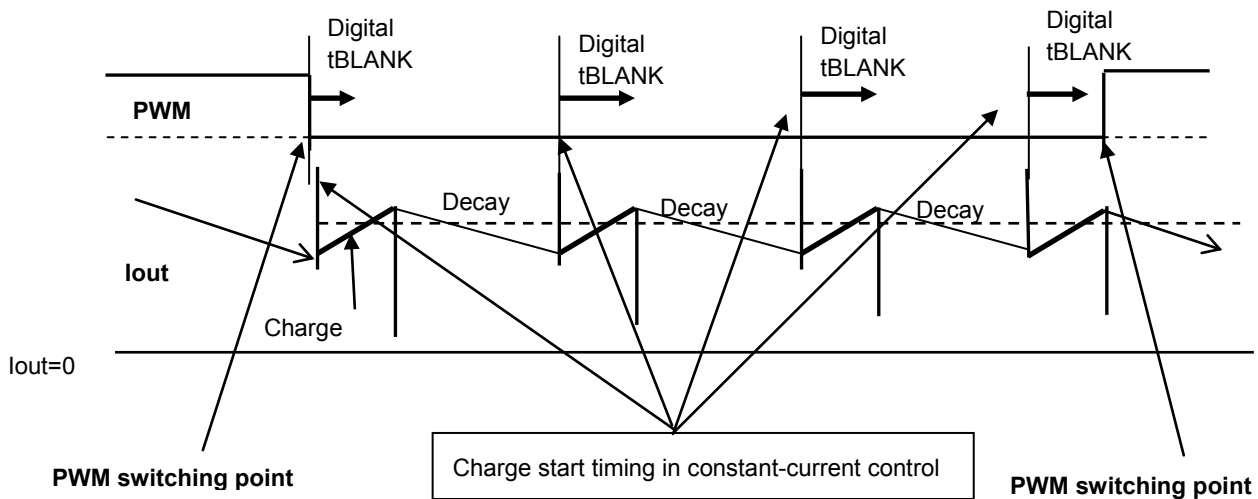

The digital tBLANK time is inserted immediately after the switching timing of externally applied PWM signals (CLK_X and ENABLE_X) such as the switching timing between short brake and charging, and also when the charging in constant-current chopper drive is started.

The digital tBLANK time becomes effective only in DC Motor mode.

Decay Mode during DC motor drive is 37.5% Mixed-Decay mode. However, the operation is in Charge mode for the first 4 CLK cycles of the whole period, which corresponds to the digital tBLANK. Thus, depending on the timing, the operation mode might be switched directly to Fast-Decay mode.

Application circuit example

The values shown in the following figure are typical values. For input conditions, see the Operating Ranges.

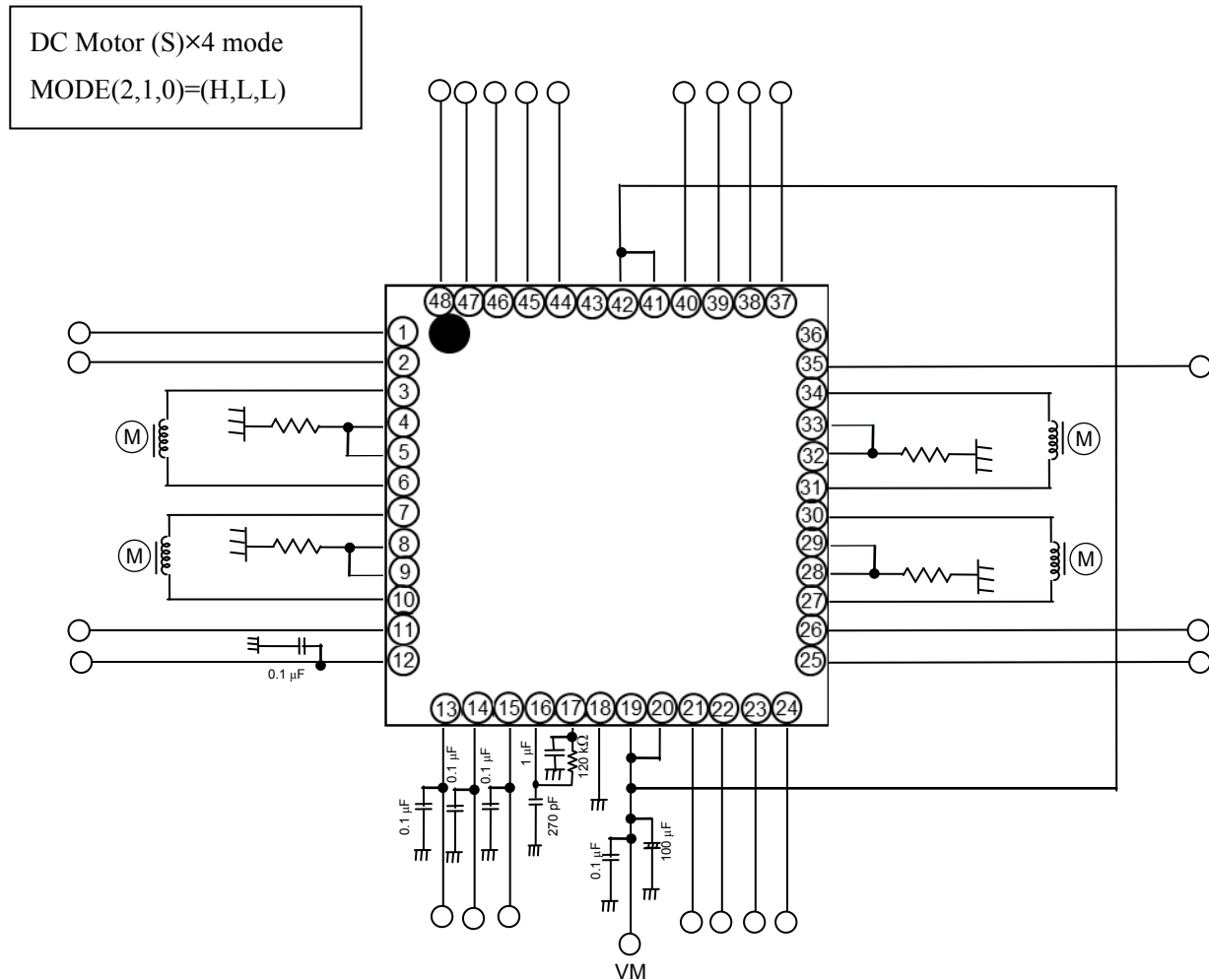

Note: It is recommended that a bypass capacitor is added if necessary. The GND wiring must become one-point-earth as much as possible.

The example of an applied circuit is for reference, and enough evaluation should be done before the mass-production design.

Toshiba does not grant any license to any industrial property rights by providing these examples of application circuits.

Notes on Contents**(1) Block Diagrams**

Some of the functional blocks, circuits, or constants in the block diagram may be omitted or simplified for explanatory purposes.

(2) Equivalent Circuits

The equivalent circuit diagrams may be simplified or some parts of them may be omitted for explanatory purposes.

(3) Timing Charts

Timing charts may be simplified for explanatory purposes.

(4) Application Circuits

The application circuits shown in this document are provided for reference purposes only. Thorough evaluation is required, especially at the mass production design stage.

Toshiba does not grant any license to any industrial property rights by providing these examples of application circuits.

IC Usage Considerations**Notes on Handling of ICs**

- (1) The absolute maximum ratings of a semiconductor device are a set of ratings that must not be exceeded, even for a moment. Do not exceed any of these ratings. Exceeding the rating(s) may cause the device breakdown, damage or deterioration, and may result injury by explosion or combustion
- (2) Do not insert devices in the wrong orientation or incorrectly. Make sure that the positive and negative terminals of power supplies are connected properly. Otherwise, the current or power consumption may exceed the absolute maximum rating, and exceeding the rating(s) may cause the device breakdown, damage or deterioration, and may result injury by explosion or combustion. In addition, do not use any device that is applied the current with inserting in the wrong orientation or incorrectly even just one time.
- (3) Use an appropriate power supply fuse to ensure that a large current does not continuously flow in case of over-current and/or IC failure. The IC will fully break down when used under conditions that exceed its absolute maximum ratings, when the wiring is routed improperly or when an abnormal pulse noise occurs from the wiring or load, causing a large current to continuously flow and the breakdown can lead smoke or ignition. To minimize the effects of the flow of a large current in case of breakdown, appropriate settings, such as Fast-blow fuse capacity, fusing time and insertion circuit location, are required.

- (4) If your design includes an inductive load such as a motor coil, incorporate a protection circuit into the design to prevent device malfunction or breakdown caused by the current resulting from the inrush current at power ON or the negative current resulting from the back electromotive force at power OFF. IC breakdown may cause injury, smoke or ignition. Use a stable power supply with ICs with built-in protection functions. If the power supply is unstable, the protection function may not operate, causing IC breakdown. IC breakdown may cause injury, smoke or ignition.

- (5) Carefully select external components (such as inputs and negative feedback capacitors) and load components (such as speakers), for example, power amp and regulator. If there is a large amount of leakage current such as input or negative feedback capacitor, the IC output DC voltage will increase. If this output voltage is connected to a speaker with low input withstand voltage, over-current or IC failure can cause smoke or ignition. (The over-current can cause smoke or ignition from the IC itself.) In particular, please pay attention when using a Bridge Tied Load (BTL) connection type IC that inputs output DC voltage to a speaker directly.

Points to Remember on Handling of ICs

- (1) **Over-current Protection Circuit**
Over-current protection circuits (referred to as current limiter circuits) do not necessarily protect ICs under all circumstances. If the Over-current protection circuits operate against the over-current, clear the over-current status immediately.
Depending on the method of use and usage conditions, such as exceeding absolute maximum ratings can cause the over-current protection circuit to not operate properly or IC breakdown before operation. In addition, depending on the method of use and usage conditions, if over-current continues to flow for a long time after operation, the IC may generate heat resulting in breakdown.

- (2) **Thermal Shutdown Circuit**
Thermal shutdown circuits do not necessarily protect ICs under all circumstances. If the thermal shutdown circuits operate against the over temperature, clear the heat generation status immediately.
Depending on the method of use and usage conditions, such as exceeding absolute maximum ratings can cause the thermal shutdown circuit to not operate properly or IC breakdown before operation.

- (3) **Heat Radiation Design**
In using an IC with large current flow such as power amp, regulator or driver, please design the device so that heat is appropriately radiated, not to exceed the specified junction temperature (T_j) at any time and condition. These ICs generate heat even during normal use. An inadequate IC heat radiation design can lead to decrease in IC life, deterioration of IC characteristics or IC breakdown. In addition, please design the device taking into considerate the effect of IC heat radiation with peripheral components.

- (4) **Back-EMF**
When a motor rotates in the reverse direction stops or slows down abruptly, a current flow back to the motor's power supply due to the effect of back-EMF. If the current sink capability of the power supply is small, the device's motor power supply and output pins might be exposed to conditions beyond absolute maximum ratings. To avoid this problem, take the effect of back-EMF into consideration in system design.

RESTRICTIONS ON PRODUCT USE

- Toshiba Corporation, and its subsidiaries and affiliates (collectively "TOSHIBA"), reserve the right to make changes to the information in this document, and related hardware, software and systems (collectively "Product") without notice.
- This document and any information herein may not be reproduced without prior written permission from TOSHIBA. Even with TOSHIBA's written permission, reproduction is permissible only if reproduction is without alteration/omission.
- Though TOSHIBA works continually to improve Product's quality and reliability, Product can malfunction or fail. Customers are responsible for complying with safety standards and for providing adequate designs and safeguards for their hardware, software and systems which minimize risk and avoid situations in which a malfunction or failure of Product could cause loss of human life, bodily injury or damage to property, including data loss or corruption. Before customers use the Product, create designs including the Product, or incorporate the Product into their own applications, customers must also refer to and comply with (a) the latest versions of all relevant TOSHIBA information, including without limitation, this document, the specifications, the data sheets and application notes for Product and the precautions and conditions set forth in the "TOSHIBA Semiconductor Reliability Handbook" and (b) the instructions for the application with which the Product will be used with or for. Customers are solely responsible for all aspects of their own product design or applications, including but not limited to (a) determining the appropriateness of the use of this Product in such design or applications; (b) evaluating and determining the applicability of any information contained in this document, or in charts, diagrams, programs, algorithms, sample application circuits, or any other referenced documents; and (c) validating all operating parameters for such designs and applications. **TOSHIBA ASSUMES NO LIABILITY FOR CUSTOMERS' PRODUCT DESIGN OR APPLICATIONS.**
- **PRODUCT IS NEITHER INTENDED NOR WARRANTED FOR USE IN EQUIPMENTS OR SYSTEMS THAT REQUIRE EXTRAORDINARILY HIGH LEVELS OF QUALITY AND/OR RELIABILITY, AND/OR A MALFUNCTION OR FAILURE OF WHICH MAY CAUSE LOSS OF HUMAN LIFE, BODILY INJURY, SERIOUS PROPERTY DAMAGE AND/OR SERIOUS PUBLIC IMPACT ("UNINTENDED USE").** Except for specific applications as expressly stated in this document, Unintended Use includes, without limitation, equipment used in nuclear facilities, equipment used in the aerospace industry, Class 3 medical devices, equipment used for automobiles, and military vehicles and munitions. **IF YOU USE PRODUCT FOR UNINTENDED USE, TOSHIBA ASSUMES NO LIABILITY FOR PRODUCT.** For details, please contact your TOSHIBA sales representative or contact us via our website.
- Do not disassemble, analyze, reverse-engineer, alter, modify, translate or copy Product, whether in whole or in part.
- Product shall not be used for or incorporated into any products or systems whose manufacture, use, or sale is prohibited under any applicable laws or regulations.
- The information contained herein is presented only as guidance for Product use. No responsibility is assumed by TOSHIBA for any infringement of patents or any other intellectual property rights of third parties that may result from the use of Product. No license to any intellectual property right is granted by this document, whether express or implied, by estoppel or otherwise.
- **ABSENT A WRITTEN SIGNED AGREEMENT, EXCEPT AS PROVIDED IN THE RELEVANT TERMS AND CONDITIONS OF SALE FOR PRODUCT, AND TO THE MAXIMUM EXTENT ALLOWABLE BY LAW, TOSHIBA (1) ASSUMES NO LIABILITY WHATSOEVER, INCLUDING WITHOUT LIMITATION, INDIRECT, CONSEQUENTIAL, SPECIAL, OR INCIDENTAL DAMAGES OR LOSS, INCLUDING WITHOUT LIMITATION, LOSS OF PROFITS, LOSS OF OPPORTUNITIES, BUSINESS INTERRUPTION AND LOSS OF DATA, AND (2) DISCLAIMS ANY AND ALL EXPRESS OR IMPLIED WARRANTIES AND CONDITIONS RELATED TO SALE, USE OF PRODUCT, OR INFORMATION, INCLUDING WARRANTIES OR CONDITIONS OF MERCHANTABILITY, FITNESS FOR A PARTICULAR PURPOSE, ACCURACY OF INFORMATION, OR NONINFRINGEMENT.**
- Do not use or otherwise make available Product or related software or technology for any military purposes, including without limitation, for the design, development, use, stockpiling or manufacturing of nuclear, chemical, or biological weapons or missile technology products (mass destruction weapons). Product and related software and technology may be controlled under the applicable export laws and regulations including, without limitation, the Japanese Foreign Exchange and Foreign Trade Law and the U.S. Export Administration Regulations. Export and re-export of Product or related software or technology are strictly prohibited except in compliance with all applicable export laws and regulations.
- Please contact your TOSHIBA sales representative for details as to environmental matters such as the RoHS compatibility of Product. Please use Product in compliance with all applicable laws and regulations that regulate the inclusion or use of controlled substances, including without limitation, the EU RoHS Directive. **TOSHIBA ASSUMES NO LIABILITY FOR DAMAGES OR LOSSES OCCURRING AS A RESULT OF NONCOMPLIANCE WITH APPLICABLE LAWS AND REGULATIONS.**