

## Reference design: PFC circuit for 3-phase 400V AC input

### Improving power supply efficiency by using a SiC MOSFET



Toshiba's reference design of a power factor correction (PFC) circuit for 3-phase 400 V AC inputs illustrates how to improve power supply efficiency using SiC MOSFETs. The design achieves a power conversion efficiency of 97% and a power factor of 0.99 or more. It is a reference design for the PFC section (gate drive circuit, sensor circuit, output power switch) of high-power converters such as electric vehicle (EV) charging stations.

The growing adoption of EVs has increased the demand for power conversion systems that must also be highly efficient and compact. This Toshiba reference design provides an excellent starting point for the PFC stage of power converters. It can be used as the basis for both prototyping and developing your application, helping it reach its full potential.

## Introduction

Solving environmental and energy problems is an important global issue. While the demand for electric power increases, the call for energy conservation, and the need for highly efficient and compact electric power conversion systems are increasing rapidly.

For example, in recent years, there has been a series of initiatives worldwide to regulate gasoline vehicles to reduce climate changing gas emissions. These initiatives occur in developed and emerging countries such as China and India and have already become a global trend. The adoption of electric vehicles (EVs) is one of the keys to responding to this trend. However, there are some issues to be solved, and it is said that the development of the charging infrastructure is the most critical issue. As it is a matter of infrastructure, the nature of national circumstances, policies, funds, technological development, standardization, etc., are complicated. Especially in emerging countries, it is expected to be challenging to develop a highly efficient EV charging system with the required performance in a short period, considering the technology they own. Therefore, there is a strong demand from engineering teams for technical support and development resources that enables a smooth and quick transition from development to commercialization.

Other than this example, the number of cases that use a reference design as an efficient development design approach increases, especially in the industrial sector, as commoditization and standardization progress. Based on device manufacturers' relevant and practical application information, highly versatile reference designs are now attracting attention.

## Toshiba Electronic Device & Storage's reference design

Toshiba Electronic Devices & Storage Corporation provides various device-based reference designs for facilitating system development and prototyping. The complete set of reference designs can be downloaded from the website's Reference Design Center. Please use the "Related Information" at the end for the reference designs introduced here (URL TBA) and links to related information. Please note that the reference designs have terms of use, so please check them as well.

This article will introduce the "PFC power supply for 3-phase 400V AC input" reference design that can be used to prototype and develop high-power conversion equipment such as an EV charging station.

### ●PFC power supply for 3-phase 400V AC input (reference design: RD044 )

This reference design is a 3-phase 400V AC input, 4kW / 750V DC output power supply. It achieves a power conversion efficiency of 97%, and a power factor of 0.99 or more by installing a PFC (power factor correction) circuit. It is a reference design for the AC line section and PFC section which includes a gate drive circuit, sensor circuit, output power switch. This reference design has the following features:

(1) Bridgeless configuration with a 3-phase totem pole configuration that switches each phase directly.

When configuring a PFC with a high power of 4kW, such as the one in this reference design, the general diode bridge rectifier + boost converter configuration has a large loss in the diode bridge and a large load on the switching elements, so a configuration in which multiple elements are connected in parallel is often used. However, although this configuration can support higher power, the conversion efficiency is not high, and the scale of the power supply unit becomes larger because large components such as inductors are required for the number of parallel circuits, or at least twice as many. The totem-pole configuration used in this reference design, in which each phase is switched directly, solves these problems because it does not require a diode bridge.

(2) High power conversion efficiency is achieved by using a SiC MOSFET for the power switch.

This reference design is a 4kW PFC that receives a three-phase 400V AC input, so a totem pole configuration requires a high withstand voltage for the switching elements. Since the required device withstand voltage for this reference design is 1000V, IGBTs are generally the choice. However, IGBTs have higher switching losses than MOSFETs due to their structure and characteristics, which limits their ability to achieve high efficiency. On the other hand, SiC MOSFETs have lower switching losses than IGBTs due to their faster switching speed, and can be operated at higher switching frequencies. Normally, the switching loss tends to increase as the switching frequency is increased, but using SiC MOSFETs makes it possible to keep the overall loss lower than that of IGBTs. In addition, the ability to increase the switching frequency makes it possible to use smaller inductors, making it possible to reduce the size of the power supply.

(3) The trade-off efficiency and EMI can be optimized by adjusting the gate drive circuit's switching speed.

The gate drive circuit, which can adjust the switching speed of the SiC MOSFET turn-on and turn-off, allows users to adjust the final switching conditions on the set. Users can optimize the switching drive conditions while monitoring EMI effects and switching surges in the final operating environment. The gate driver IC in this reference design is the TLP5214A, which has a sink and source current capability of 4A, enough to drive the gate charge and discharge current of 1200V SiC MOSFETs during switching. The TLP5214A is also equipped with overcurrent protection and UVLO function to provide circuit protection in case of abnormalities.

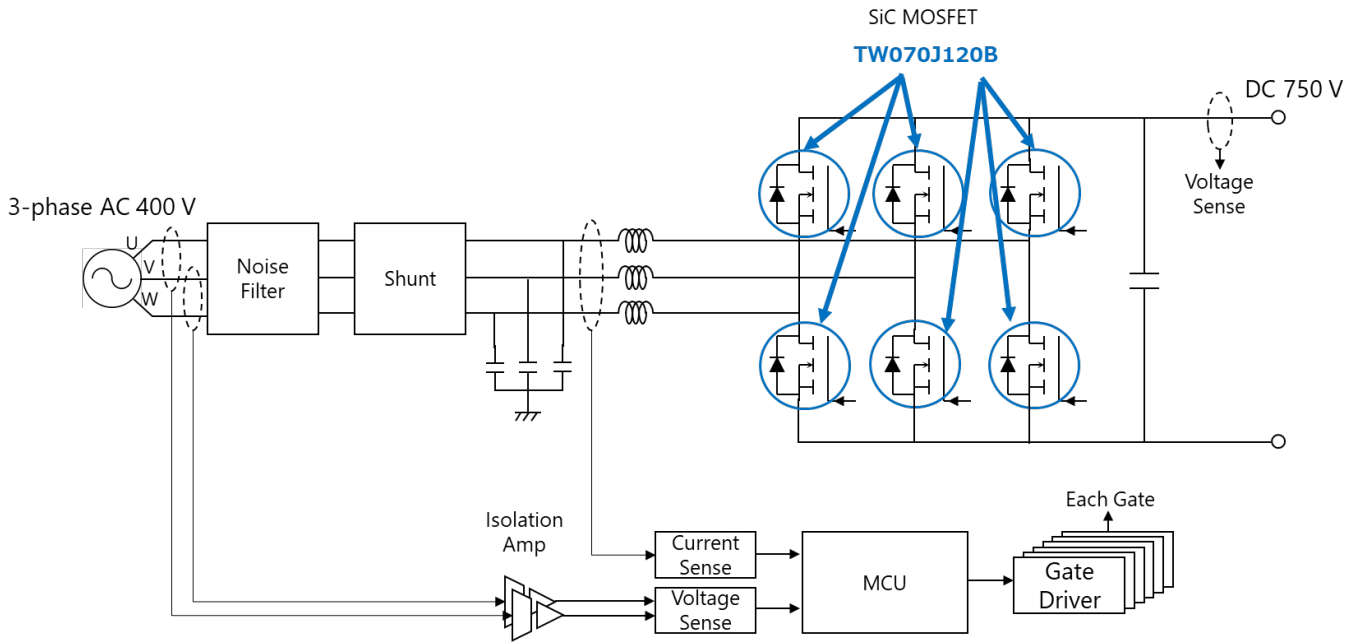

Figure 1: Functional block diagram of reference design of PFC power supply for 3-phase 400V AC input

The main specifications are as follows.

- AC input voltage rating: 3-phase 400V AC (312V AC to 528V AC)
- AC frequency: 50 Hz  $\pm$  0.2 Hz, 60 Hz  $\pm$  0.3 Hz
- Maximum AC input current rating 6.2A RMS
- Output voltage rating: 750V DC  $\pm$  1%
- Output power rating: 4.0 kW
- Switching frequency: 50 kHz
- Power conversion efficiency: 97% (at 400V AC input, 4.0 kW output)
- Control method: Power factor 1 control, DC voltage control, power factor 0.99 or more
- Dielectric strength: 2500 V (main circuit-control circuit)

This reference circuit's high conversion efficiency is achieved using a SiC MOSFET as the switching element, which has a faster switching characteristic than an IGBT. SiC power devices have plenty of potential in power conversion circuits and are widely used in related applications.

## Bidirectional Charging Application Example

Here is an example application that uses this reference design. It is a system that permits bidirectional charging by converting 3-phase 400V AC to DC with a high efficiency PFC power supply and combining it with bidirectional DC-DC converter.

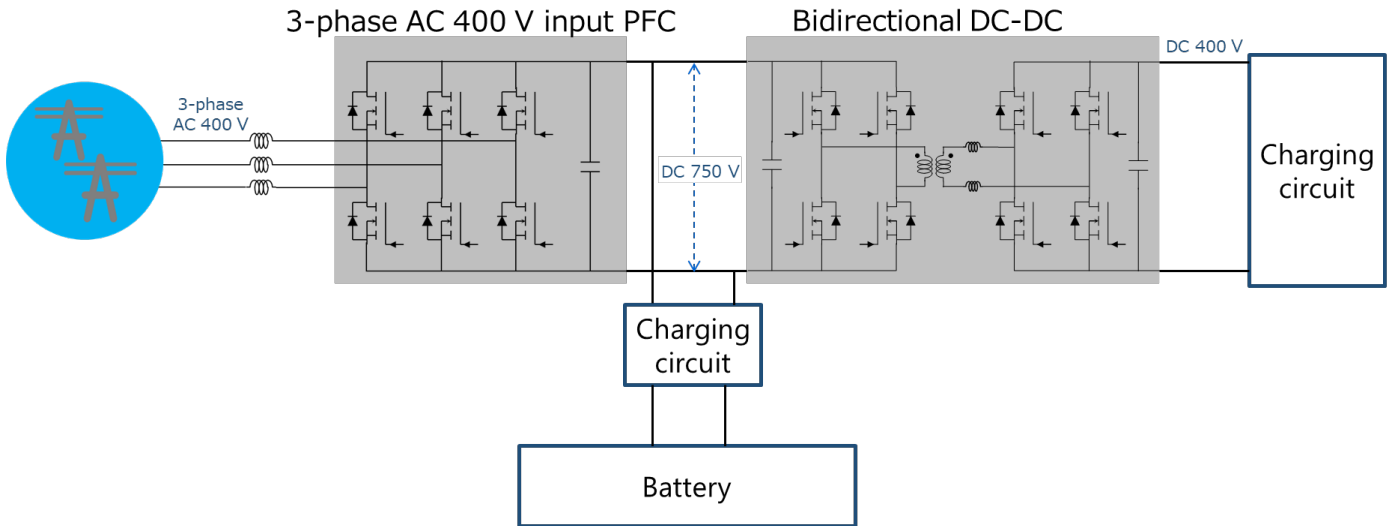

Figure 2: Image of EV charging system using the reference design of PFC power supply for 3-phase 400V AC input

By combining this reference design together with Toshiba’s bidirectional DC-DC power supply reference design, it is possible to proceed with system development quickly and easily.

## Features of a SiC MOSFET

The power device's performance significantly influences the efficiency of the power conversion system, that is, reducing the loss. Therefore, in addition to the conventional Si (silicon), the number of power devices using wideband gap semiconductor materials such as SiC (silicon carbide) and GaN (gallium nitride) is increasing.

In the reference design highlighted above, the conversion efficiency is improved by adopting a SiC MOSFET as indicated. The following shows a comparative loss example of IGBT (Insulated Gate Bipolar Transistors) and SiC MOSFETs.

### ●Comparison of loss between SiC MOSFET and IGBT

The switching transistor's loss is the sum of the switching losses, the conduction loss due to the on-resistance, and the forward voltage loss of the internal diode. Among them, the switching loss accounts for nearly 90% of the total. Figure 3 is a comparative example of switching waveforms and loss  $E_{on}$  during turn-on of the SiC MOSFET and IGBT. The SiC MOSFET adopted for comparison is Toshiba's [TW070J120B](#) that is used in this reference circuit, and the IGBT is a high-speed switching type made by another company.

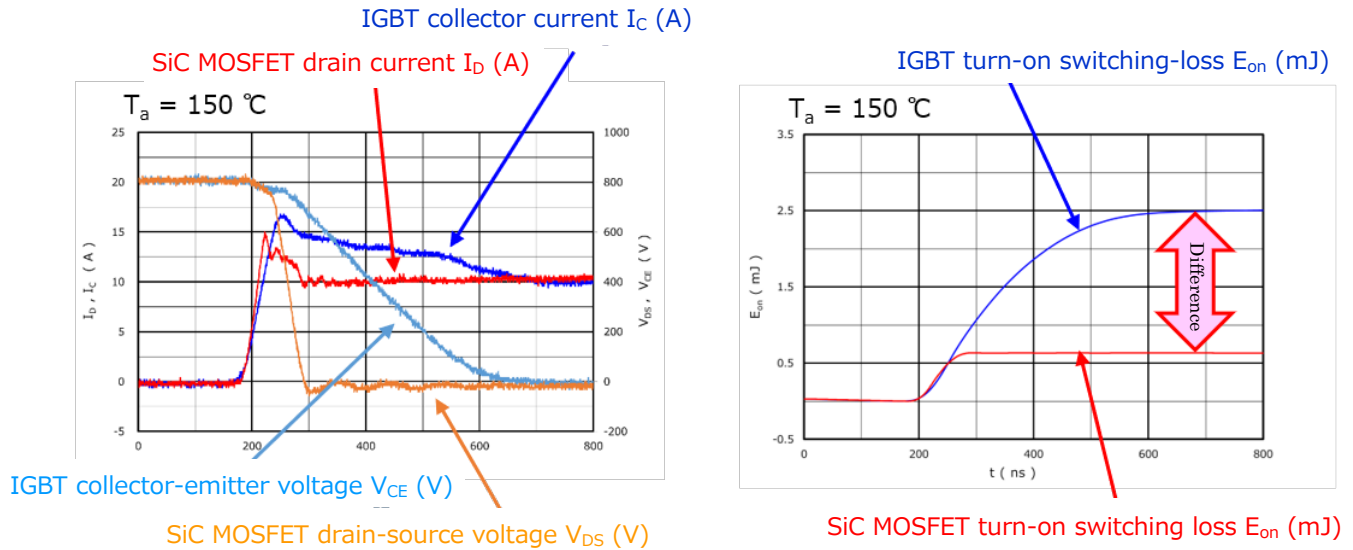

●SiC MOSFET test conditions

$V_{DD} = 800\text{ V}$ ,  $I_D = 10\text{ A}$ ,  $T_a = 150\text{ }^\circ\text{C}$ ,  $V_{GS} = 20\text{ V} / -5\text{ V}$ , Dielectric load:  $L = 1\text{ mH}$ , External gate resistance  $R_G = 150\Omega$

Source-drain diode is used as freewheeling diode (FWD) in parallel with inductive load

●IGBT test conditions

$V_{CC} = 800\text{ V}$ ,  $I_C = 10\text{ A}$ ,  $T_a = 150\text{ }^\circ\text{C}$ ,  $V_{GE} = 20\text{ V} / -5\text{ V}$ , Dielectric load:  $L = 1\text{ mH}$ , External gate resistance  $R_G = 47\Omega$

Emitter-collector diode is used as FWD in parallel with inductive load

\* Test conditions set to match the inclination  $dI(D)/dt$  of the  $I_D$  and  $I_C$  at turn-on

Figure 3: Comparative example of switching waveform and loss  $E_{on}$  at turn-on of SiC MOSFET and IGBT

This example shows that the turn-on loss of the IGBT is 2.5 mJ and that of the SiC MOSFET is 0.6 mJ, so the turn-on loss can be reduced by 76% when the switching transistor is replaced from the IGBT to the SiC MOSFET. This difference in loss is mainly due to the difference in switching characteristics (speed) between  $V_{DS}$  and  $V_{CE}$  in the switching waveform diagram. The SiC MOSFET turns on full almost instantly, and the  $I_D$  flows accordingly, but the IGBT takes time to turn on completely, and the delay accounts for the losses.

Also, Figure 4 is a comparative example of the sum of the turn-on and turn-off switching losses, the conduction loss due to the on-resistance, and the loss due to the forward voltage of the internal diode SiC MOSFET and IGBT by simulation. The conditions are  $V_{CC} = 400\text{ V}$ ,  $I_o = 7.0\text{ Arms}$ , power factor = 1, 3-phase modulation,  $T_j = 150\text{ }^\circ\text{C}$ . From this result, it can be seen that the SiC MOSFET which reduce the loss of about 28 W compared to the IGBT, which contributes to the efficiency improvement of the equipment.

In this way, even in general-purpose existing power conversion applications, it is possible to significantly reduce

losses by replacing an IGBT with a SiC MOSFETs. By reducing the loss, it is possible to reduce the circuit's size if the same power is handled. Also, if they are the same size, they can handle more power.

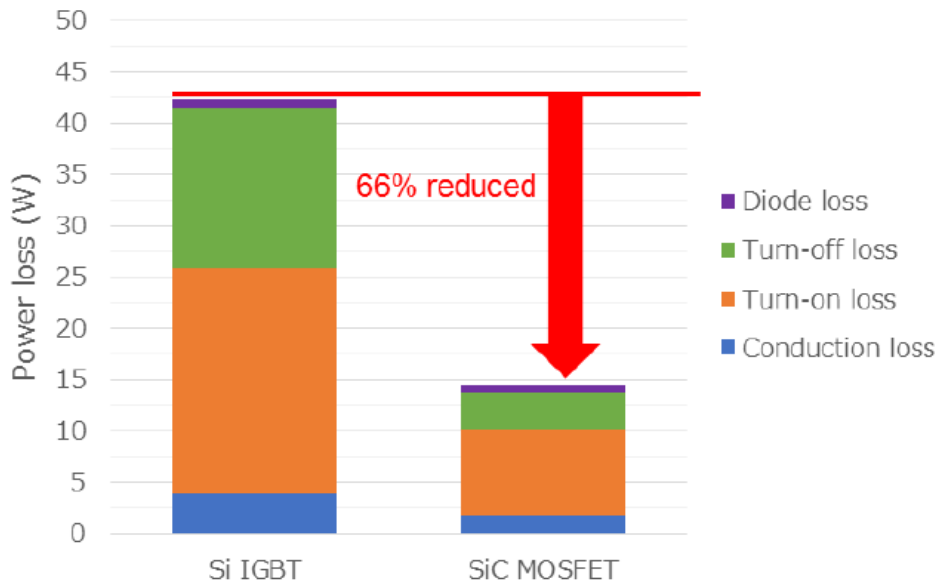
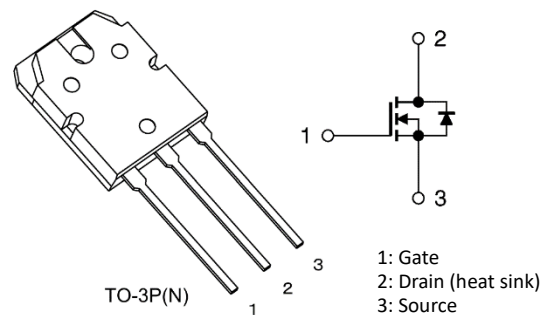

Figure 4: Comparative example of SiC MOSFET and IGBT losses

## ●SiC MOSFET: [TW070J120B](#)

The TW070J120B used in this reference circuit is an N-channel SiC MOSFET with a built-in SiC Schottky barrier diode (SiC SBD) designed using Toshiba's 2nd generation chip. The main specifications are shown below.

- Built-in SiC Schottky barrier diode
- Low built-in diode forward voltage:  $V_{DSF} = -1.35 \text{ V}$  (typ)
- High withstand voltage:  $V_{DSS} = 1200 \text{ V}$
- Wide gate-source voltage:  $V_{GSS} = +25 \text{ V}$  to  $-10 \text{ V}$
- Low on-resistance:  $R_{DS(ON)} = 70 \text{ m}\Omega$  (typ)
- High gate threshold:  $V_{th} = 4.2 \text{ V}$  to  $5.8 \text{ V}$



The built-in SiC Schottky barrier diode realizes a  $V_{DSF}$  lower than that of the MOSFET body (parasitic) diode and reduces the diode's conduction loss. Also, because it adopts a diode with a high  $I_{FSM}$  (peak forward surge current), it has excellent surge current withstand capability. From the viewpoint of reliability, the built-in diode makes the component count one, which can help to reduce the constituent circuits' failure rate.

The gate-source voltage rating  $V_{GSS}$  has a broader range than competing products. The wide tolerance of  $V_{GSS}$  facilitates an easier design.

In addition, the gate threshold voltage standard is specified at a higher value than competing products. This makes it less likely to malfunction due to fluctuations in the gate voltage and noise.

The TW070J120B is an easy-to-design in SiC MOSFET with low loss and robustness because of these features.

## ●Gate drive of SiC MOSFET

The gate drive of SiC MOSFET is a method that considers the physical characteristics and the high-speed switching characteristics of SiC. Below is a summary of the points using the TW070J120B as an example. For details, please refer to the related application notes.

<Points of SiC MOSFET gate control>

- (1) Strictly adhere to the absolute maximum rating of -10 V to 25 V for the gate-source voltage.
- (2) Set the gate voltage at turn-on to 18 V to 20 V.
- (3) Set the gate voltage at turn-off to 0 to -5 V.
- (4) It is necessary to fully charge the gate-source capacitance ( $C_{GS}$ ) with the gate charge.

To apply the gate voltage and turn it on, the gate-source capacitance must be charged with the gate charge. The standard gate charge when  $V_{GS}$  is 0 to 20 V is 70 nC ( $V_{DD} = 800$  V,  $V_{GS} = 20$  V,  $I_D = 36$  A). It is necessary to carry a current at the switching frequency used that can sufficiently charge this charge.

The design engineer should also note that standard conditions are set for the gate drive circuit in the reference design introduced earlier. It is possible to optimize by checking and evaluating the actual operation.

## Summary

In recent years, the demand for shortening the time to market of products has become tighter, and engineers involved in the development and design of equipment are required to make it production-ready in the shortest time possible. Manufacturer-supplied reference designs significantly aid the design and prototyping process.

The reference design of the "PFC power supply for 3-phase 400V AC input" introduced here is a proposal intended for higher efficiency and miniaturization of power conversion applications. The key to reducing loss for higher efficiency is to replace the power switch from a conventional IGBT to a SiC MOSFET. It is already widely known that SiC power devices are an advantageous option in high power applications, but to take advantage of their excellent properties, it is necessary to understand the characteristics of SiC power devices. In this respect, the reference design provides standard conditions and helps facilitate the development design smoothly and quickly.

From an application perspective, EVs' spread is an urgent need worldwide to reduce climate changing gas emissions. Development teams can use this reference design for infrastructure designs such as for EV charging stations. Such reference designs can be beneficial, especially for development in emerging countries.

Toshiba company plans to increase the number of reference designs provided in the future. Toshiba will ramp up development of designs that incorporate SiC power devices for high-power conversion applications. At the same time, they are developing a new generation of SiC power devices. Toshiba plan to announce a third-generation product in addition to the current second-generation product shortly.



## Information Link

- [PFC circuit for 3-phase 400V AC input \(reference design : RD044\)](#)
- [Reference Design Center](#)
- [SiC MOSFET Product Page](#)
- [SiC MOSFET : TW070J120B](#)

---

## Toshiba Electronic Devices & Storage Corporation

<https://toshiba.semicon-storage.com/ad/contact.html>



## RESTRICTIONS ON PRODUCT USE

Toshiba Corporation and its subsidiaries and affiliates are collectively referred to as “TOSHIBA”.

Hardware, software and systems described in this document are collectively referred to as “Product”.

- TOSHIBA reserves the right to make changes to the information in this document and related Product without notice.
- This document and any information herein may not be reproduced without prior written permission from TOSHIBA. Even with TOSHIBA's written permission, reproduction is permissible only if reproduction is without alteration/omission.
- Though TOSHIBA works continually to improve Product's quality and reliability, Product can malfunction or fail. Customers are responsible for complying with safety standards and for providing adequate designs and safeguards for their hardware, software and systems which minimize risk and avoid situations in which a malfunction or failure of Product could cause loss of human life, bodily injury or damage to property, including data loss or corruption. Before customers use the Product, create designs including the Product, or incorporate the Product into their own applications, customers must also refer to and comply with (a) the latest versions of all relevant TOSHIBA information, including without limitation, this document, the specifications, the data sheets and application notes for Product and the precautions and conditions set forth in the "TOSHIBA Semiconductor Reliability Handbook" and (b) the instructions for the application with which the Product will be used with or for. Customers are solely responsible for all aspects of their own product design or applications, including but not limited to (a) determining the appropriateness of the use of this Product in such design or applications; (b) evaluating and determining the applicability of any information contained in this document, or in charts, diagrams, programs, algorithms, sample application circuits, or any other referenced documents; and (c) validating all operating parameters for such designs and applications. **TOSHIBA ASSUMES NO LIABILITY FOR CUSTOMERS' PRODUCT DESIGN OR APPLICATIONS.**
- **PRODUCT IS NEITHER INTENDED NOR WARRANTED FOR USE IN EQUIPMENTS OR SYSTEMS THAT REQUIRE EXTRAORDINARILY HIGH LEVELS OF QUALITY AND/OR RELIABILITY, AND/OR A MALFUNCTION OR FAILURE OF WHICH MAY CAUSE LOSS OF HUMAN LIFE, BODILY INJURY, SERIOUS PROPERTY DAMAGE AND/OR SERIOUS PUBLIC IMPACT ("UNINTENDED USE").** Except for specific applications as expressly stated in this document, Unintended Use includes, without limitation, equipment used in nuclear facilities, equipment used in the aerospace industry, lifesaving and/or life supporting medical equipment, equipment used for automobiles, trains, ships and other transportation, traffic signaling equipment, equipment used to control combustions or explosions, safety devices, elevators and escalators, and devices related to power plant. **IF YOU USE PRODUCT FOR UNINTENDED USE, TOSHIBA ASSUMES NO LIABILITY FOR PRODUCT.** For details, please contact your TOSHIBA sales representative or contact us via our website.
- Do not disassemble, analyze, reverse-engineer, alter, modify, translate or copy Product, whether in whole or in part.
- Product shall not be used for or incorporated into any products or systems whose manufacture, use, or sale is prohibited under any applicable laws or regulations.
- The information contained herein is presented only as guidance for Product use. No responsibility is assumed by TOSHIBA for any infringement of patents or any other intellectual property rights of third parties that may result from the use of Product. No license to any intellectual property right is granted by this document, whether express or implied, by estoppel or otherwise.

• **ABSENT A WRITTEN SIGNED AGREEMENT, EXCEPT AS PROVIDED IN THE RELEVANT TERMS AND CONDITIONS OF SALE FOR PRODUCT, AND TO THE MAXIMUM EXTENT ALLOWABLE BY LAW, TOSHIBA (1) ASSUMES NO LIABILITY WHATSOEVER, INCLUDING WITHOUT LIMITATION, INDIRECT, CONSEQUENTIAL, SPECIAL, OR INCIDENTAL DAMAGES OR LOSS, INCLUDING WITHOUT LIMITATION, LOSS OF PROFITS, LOSS OF OPPORTUNITIES, BUSINESS INTERRUPTION AND LOSS OF DATA, AND (2) DISCLAIMS ANY AND ALL EXPRESS OR IMPLIED WARRANTIES AND CONDITIONS RELATED TO SALE, USE OF PRODUCT, OR INFORMATION, INCLUDING WARRANTIES OR CONDITIONS OF MERCHANTABILITY, FITNESS FOR A PARTICULAR PURPOSE, ACCURACY OF INFORMATION, OR NONINFRINGEMENT.**

• Product may include products using GaAs (Gallium Arsenide). GaAs is harmful to humans if consumed or absorbed, whether in the form of dust or vapor. Handle with care and do not break, cut, crush, grind, dissolve chemically or otherwise expose GaAs in Product.

• Do not use or otherwise make available Product or related software or technology for any military purposes, including without limitation, for the design, development, use, stockpiling or manufacturing of nuclear, chemical, or biological weapons or missile technology products (mass destruction weapons). Product and related software and technology may be controlled under the applicable export laws and regulations including, without limitation, the Japanese Foreign Exchange and Foreign Trade Law and the U.S. Export Administration Regulations. Export and re-export of Product or related software or technology are strictly prohibited except in compliance with all applicable export laws and regulations.

• Product is subject to foreign exchange and foreign trade control laws.

• Please contact your TOSHIBA sales representative for details as to environmental matters such as the RoHS compatibility of Product. Please use Product in compliance with all applicable laws and regulations that regulate the inclusion or use of controlled substances, including without limitation, the EU RoHS Directive. **TOSHIBA assumes no liability for damages or losses occurring as a result of noncompliance with applicable laws and regulations.**

---

## Toshiba Electronic Devices & Storage Corporation