

3-Phase Brushless DC Motor Driver Using TC78B043FNG and TPD4204F

Reference Guide

RD259-RGUIDE-02

Toshiba Electronic Devices & Storage Corporation

Table of Contents

1. Introduction	3
2. Specifications and Appearance	4
2.1. Specifications.....	4
2.2. Block Diagram	5
2.3. Appearance	5
2.4. Component layout	6
3. Schematic, Bill of Materials, and PCB Pattern Diagram	7
3.1. Schematic.....	7
3.2. Bill of Materials	7
3.3. PCB Pattern Diagram.....	7
4. Names and Functions of Each Section.....	9
4.1. Motor Connection (U, V, W).....	9
4.2. Hall Elements	10
4.3. External Power supply and Control Signals (VM, VCC, VSP, FG, GND)	10
4.4. SPI Communication Connection (SCK, SDI, SDO, GND)	11
5. Operation Description.....	12
5.1. Preparation	12
5.2. Startup Procedure	12
5.3. Stop Procedure.....	12
5.4. TC78B043FNG Parameter Re-Adjustment Procedure.....	12
6. Common Precautions for Evaluation.....	13

1. Introduction

This reference guide (hereinafter referred to as "this guide") describes the specification, usage and characteristics of the reference design for 3-Phase Brushless DC Motor Driver Using TC78B043FNG and TPD4204F (hereinafter referred to as "this design").

This design guide (hereinafter referred to as "this guide") explains each part of the reference design for 3-Phase Brushless DC Motor Driver Using TC78B043FNG and TPD4204F (hereinafter referred to as "this design").

In recent years, for 3-phase brushless DC motors used in home appliances and industrial equipment such as air conditioners and air purifiers, there is an increasing trend toward adopting Interior Permanent Magnet (IPM) motors ^(note 1) instead of Surface Permanent Magnet (SPM) motors ^(note 2) to achieve lower cost, higher output, and higher torque. However, IPM motors tend to generate noise, creating a demand for motor controllers capable of low-noise and highly efficient control.

The motor controller [TC78B043FNG](#) enables low-noise motor operation by high-resolution sine-wave drive and sine-wave startup control.

In addition, since it incorporates nonvolatile memory (NVM), various parameters can be adjusted using Serial Peripheral Interface (SPI) ^(note 3) communication to write settings into the NVM, allowing for high-efficiency motor control through adjustments such as advance-angle control.

Furthermore, since TC78B043FNG contains initial settings suitable for typical motors used in appliances such as air conditioners and air purifiers, the motor can operate without SPI-based parameter writing. The device also provides various control-setting pins ^(Note 4) (FGC, LATYPE, LAOFS, LA) that allow adjustment of certain parameters, such as advance-angle control, by setting terminal voltages ^(Note 5).

In this design, an Intelligent Power Device integrating 3-phase inverter switches and gate drivers into a compact package is used for motor drive. [TPD4204F](#) (MOSFET built-in type, Maximum voltage rating 600 V, maximum output current (DC) rating 2.5 A, SSOP30 package) achieves high-efficiency motor drive in a compact PCB implementation.

Note 1: Surface Permanent Magnet (SPM) Motor:

Motor with a permanent magnet attached to the surface of the rotor.

Note 2: Interior Permanent Magnet (IPM) Motor:

Motor with a permanent magnet embedded inside the rotor.

Note 3: Serial Peripheral Interface:

Synchronous serial communication. A protocol for synchronously sending and receiving data.

Note 4: FGC: Input for setting Rotation pulse / Sine Wave Reset method

LATYPE: Input for setting Lead Angle Control type / with or without Stop Sequence

LAOFS: Input for setting Lead Angle value / SPD value offset

LA: Input for setting Maximum Lead Angle value / Fixed Lead Angle value

Note 5: TC78B043FNG allows more detailed readjustment of motor control parameters through NVM writing via SPI communication than is possible using the various control setting terminals

2. Specifications and Appearance

2.1. Specifications

This design is intended for a 10-pole IPM motor. To use this design as-is, the motor must be constructed so that the rotor pole count, slot structure, and Hall-sensor placement match the geometry of the board, after which the design board should be integrated into the motor.

(Please refer to the datasheet, schematic, and layout pattern diagram to confirm the compatibility.)

The main specifications of this design are shown in Table 2.1

Table 2.1 Specifications of This Design

Item	Condition	Min.	Typ.	Max.	Unit
VM power supply terminal	Maximum rating	—	—	600	V
	Operation range	50	280	450	V
Motor current	Maximum rating	—	—	2	A
	Current limit threshold	—	1	—	A
VCC power supply terminal	Maximum rating	—	—	18	V
	Operation range	13.5	15	16.5	V
VSP speed command terminal	Maximum rating	—	—	25	V
	Normal control operation	0	—	7.3	V
FG rotation pulse output terminal	Maximum voltage rating	—	—	50	V
	Maximum current rating	—	—	100	mA
SPI interface terminals (SDI, SCK, SDO)	Maximum voltage rating	—	—	6	V
	H level	2	5	5.5	V
	L level	0	—	0.8	V
	Clock frequency	15	—	500	kHz
Protection functions	Thermal shut down (TSD), Power Supply Low Voltage Detection, Current limiting function, Output over-current detection (ISD), Lock protection function				
Board					
Board Layer Composition	FR-4 1.6mm Thick, 2 Layer Configuration 50μm Copper Thickness				

2.2. Block Diagram

The block diagram to understand the function behavior of this design is shown in Figure 2.1.

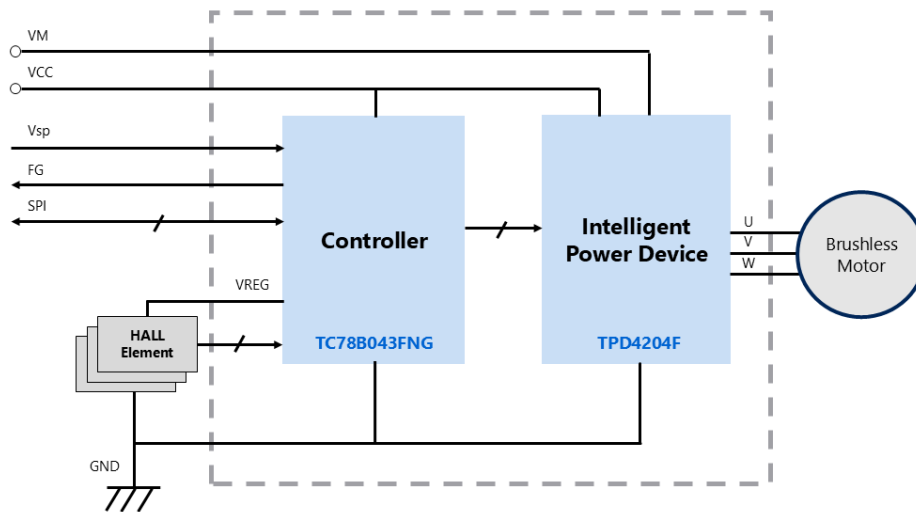

Figure 2.1 Block Diagram

2.3. Appearance

The board appearance of this design is shown in Figure 2.2.

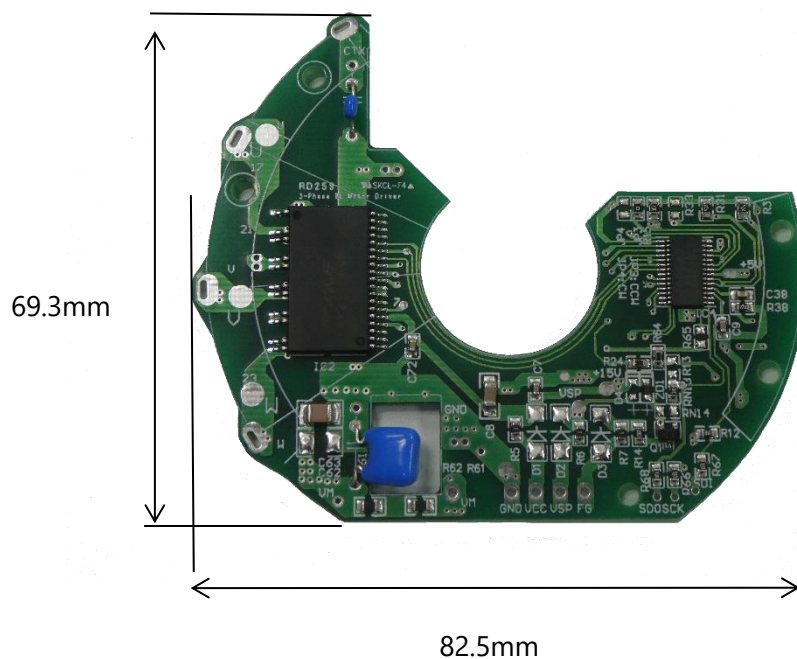

Figure 2.2 Board Appearance

Board size: 82.5 mm × 69.3 mm × 11 mm (Note)

Weight: 12 g

Note: Height can be reduced by laying down the capacitors

2.4. Component layout

The layout of components of this design is shown in Figure 2.3.

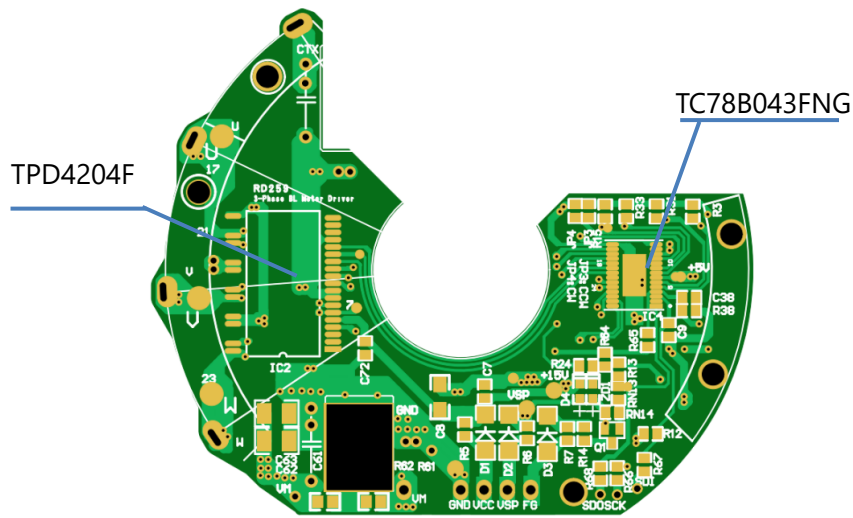

<Top View>

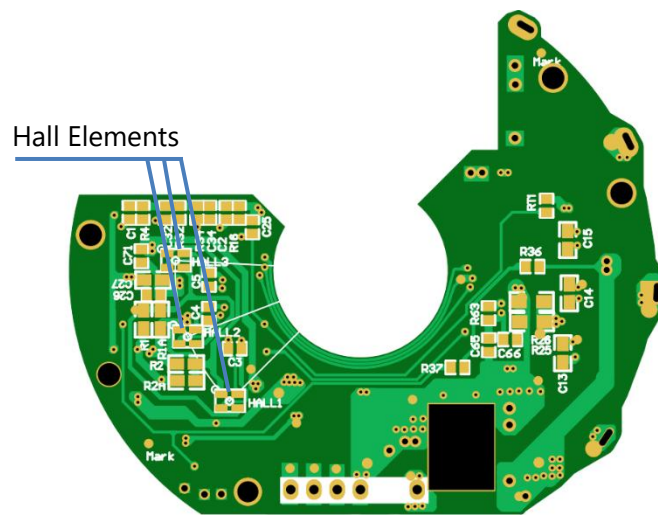

<Bottom View>

Figure 2.3 Layout of Main Components

3. Schematic, Bill of Materials, and PCB Pattern Diagram

3.1. Schematic

Refer to the following file.
RD259-SCHEMATIC-xx.pdf
(xx is the revision number.)

3.2. Bill of Materials

Refer to the following files.
RD259-BOM-xx.pdf
(xx is the revision number.)

3.3. PCB Pattern Diagram

PCB pattern diagram of this design is shown in Figure. 3.1.
Refer to the following files.
RD259-LAYER-xx.pdf
(xx is the revision number.)

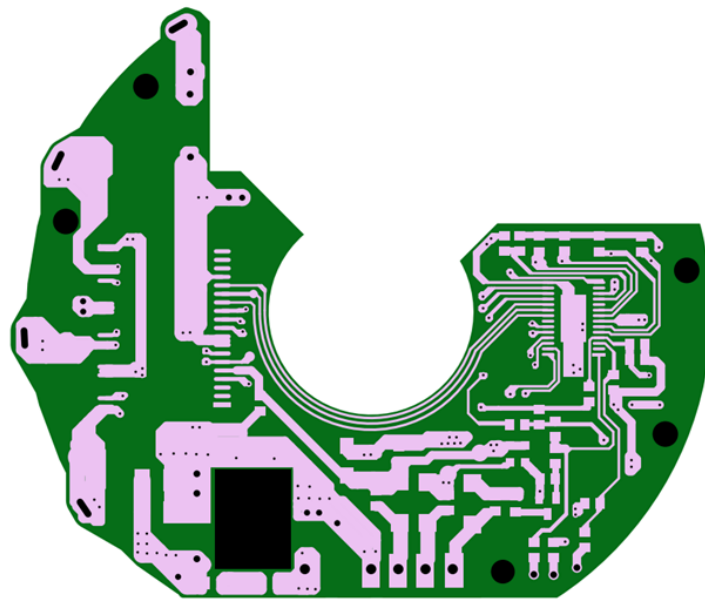

<Layer 1>

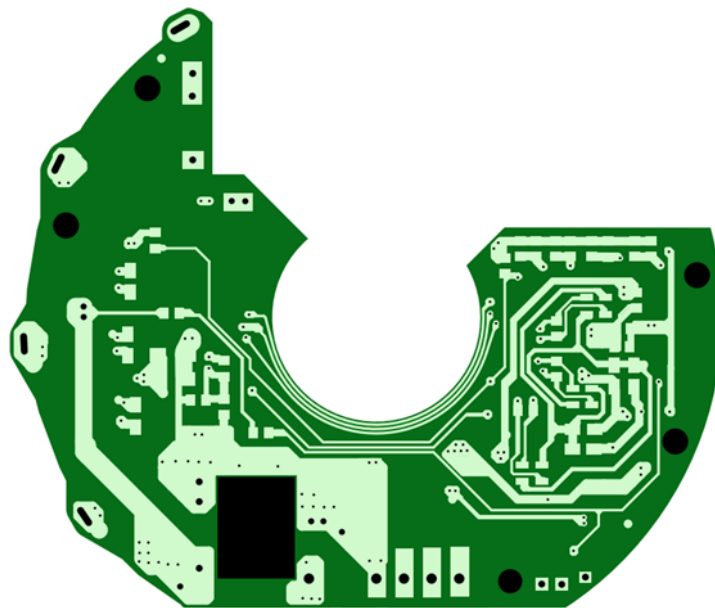

<Layer 2>

Figure 3.1 PCB Pattern Diagram (Top View)

4. Names and Functions of Each Section

4.1. Motor Connection (U, V, W)

This is the part where the coils of each U, V, and W phase of the motor are connected to the design board. Bring a 10-pole, 3-phase brushless IPM motor that matches this design, integrate the design board into the motor, and connect the U, V, and W outputs to the corresponding coils.

Please refer to the datasheet, circuit diagrams, and layout diagrams to verify that the U, V, and W phase connection order as well as the Hall sensor arrangement are compatible with this design board.

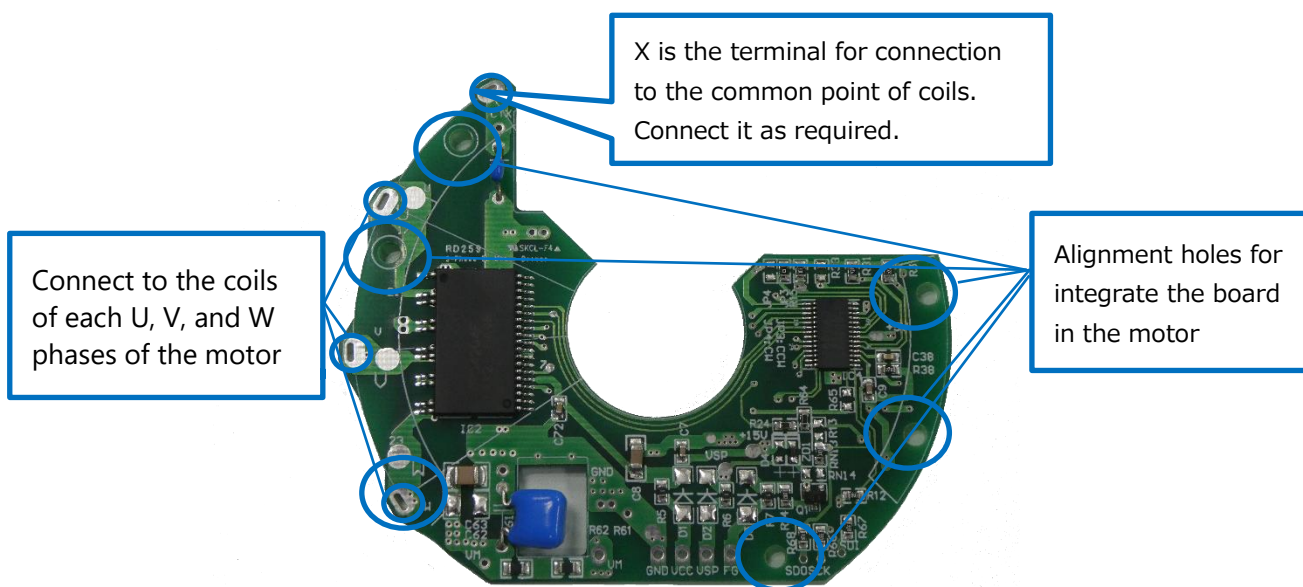

<Top view>

Figure 4.1 U, V and W Phase Coil Connections

4.2. Hall Elements

Please refer to the datasheet, circuit diagrams, and layout diagrams to verify that the Hall sensor arrangement of this design board is compatible with motor.

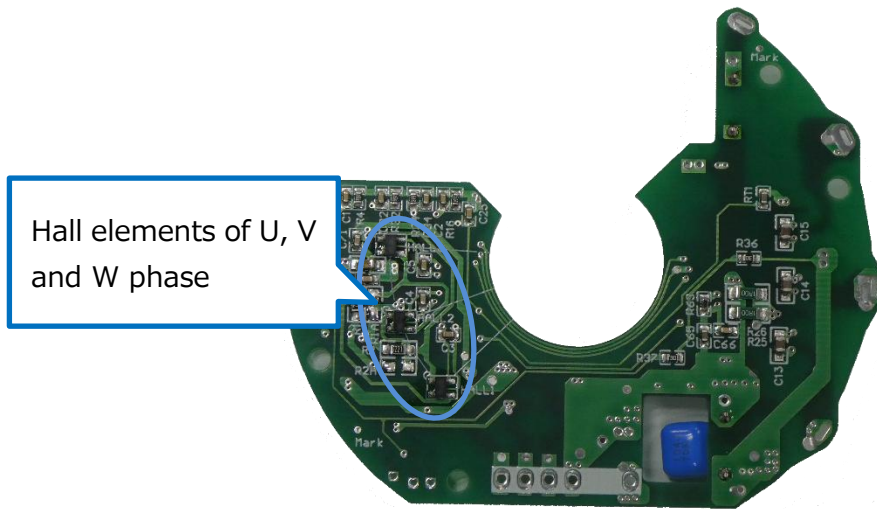

<Bottom view>

Figure 4.2 Layout of Hall elements

4.3. External Power supply and Control Signals (VM, VCC, VSP, FG, GND)

Connect the DC power supply voltage to VM: 280 V (Typ.), VCC: 15 V (Typ.), and GND.

Use cables with sufficient rated capacity for the required current.

Connect the speed-command input control signal to VSP, and monitor the rotation-pulse output signal from FG.

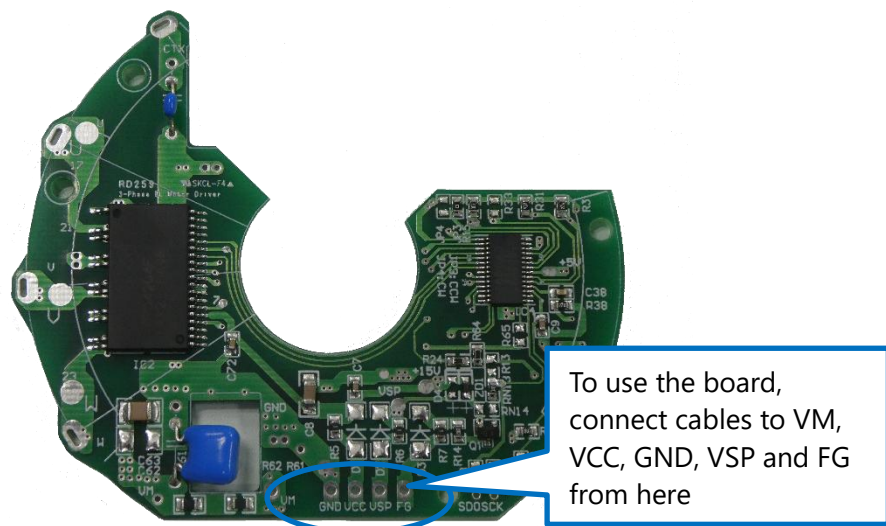

<Top view>

Figure 4.3 Layout of VM, VCC, GND, VSP, and FG connections

4.4. SPI Communication Connection (SCK, SDI, SDO)

When readjusting the parameter settings of TC78B043FNG, connect SCK, SDI, and SDO from the SPI communication connection to an external MCU or another device supports SPI.

Please also ensure that the GND of the MCU and the GND of the board are connected together.

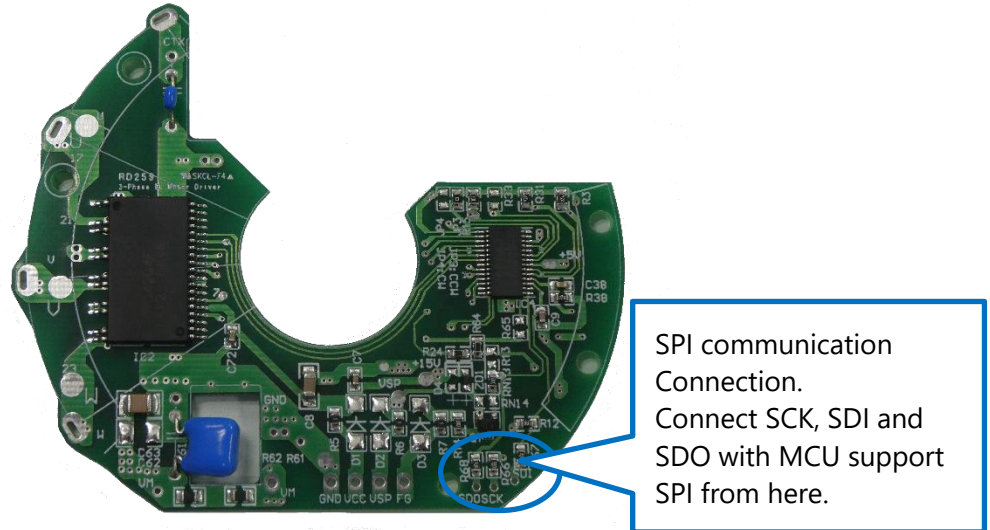

<Top View>

Figure 4.4 SPI Communication Connection

5. Operation Description

The recommended procedure for operation using this design is described below.

5.1. Preparation

- Bring a 10-pole, 3-phase brushless IPM motor that matches this design, integrate the design board into the motor, and connect the U, V, and W outputs to the corresponding coils.
Please refer to the datasheet, circuit diagrams, and layout diagrams to verify that the U, V, and W phase connection order as well as the Hall sensor arrangement are compatible with this design board.
- Connect cables to VM, VCC, VSP, FG and GND.
Connect the FG pin to 5 V (Typ.) through a pull-up resistor so that the rotation pulse signal can be monitored by an external MCU or other devices.

5.2. Startup Procedure

The recommended procedure for driving a motor using this design is shown below.

1. Connect VSP to an external MCU or similar controller and set it to 0 V.
2. Apply 15 V (Typ.) to VCC from a power supply.
3. Apply 280 V (Typ.) to VM from a power supply.
4. Drive the motor by varying the VSP control voltage.

5.3. Stop Procedure

The recommended procedure for stopping the motor in this design is shown below.

1. Set VSP to 0V to stop the motor.
2. Turn OFF the 280V (Typ.) power supply of VM.
3. Turn OFF the 15 V (Typ.) power supply of VCC.

5.4. TC78B043FNG Parameter Re-Adjustment Procedure

The recommended steps for readjusting the parameter settings of TC78B043FNG in this design is shown below.

1. Connect the CLK, SDI and SDO of SPI Communication Connection to an external MCU that supports SPI.
2. Apply 15 V (Typ.) to VCC from a power supply.
3. Set parameters to the registers of TC78B043FNG, then write them into the NVM.
After the NVM write is complete, the parameter settings are readjusted
4. After writing the parameters of TC78B043FNG into its NVM,
turn off the power supply for VCC, and disconnect the board from the MCU.
5. Following the instructions of Startup procedure" to drive the motor.

6. Common Precautions for Evaluation

Please read and follow the precautions below to ensure safe evaluation work.

• Precautions for Electric Shock Prevention

- Before applying power, **confirm that the polarity of connectors, terminals, and wiring is correct.**
- Some parts of the board may be exposed to high voltage. **Do not touch the board or components while power is applied.**
- Even after the power is turned off, capacitors may retain residual charge. **Ensure that all capacitors are fully discharged before touching the board.**
- When measuring voltage or current waveforms, **take sufficient precautions to avoid electric shock and maintain a safe distance.**

• Precautions for Burn Prevention (High-Temperature Components)

- MOSFETs, diodes, inductors, coils, and semiconductor devices may become **very hot during operation.** Handle them carefully to avoid burns.
- Under high load conditions, heat generation increases. **Use appropriate cooling (such as fans).**
- Component temperatures may remain high immediately after power-off. **Allow sufficient cooling time before touching.**

• Precautions for the Evaluation Environment

- During operation checks, implement safety measures such as **covering the board with a non-conductive enclosure** if necessary (e.g., acrylic case).
- When using motors or other moving parts, **take measures to prevent contact during operation.**
- For designs with shunt or jumper settings, **verify that the settings are correct before operation.**

• Other Precautions

- Loads connected to output terminals may generate heat. **Pay attention to load temperature rise.**
- Keep flammable and conductive materials away during evaluation to **avoid short circuits and accidents.**

Terms of Use

This terms of use is made between Toshiba Electronic Devices and Storage Corporation ("We") and Customer who downloads or uses this Reference Design. Customer shall comply with this terms of use. This Reference Design means all documents and data in order to design electronics applications on which our semiconductor device is embedded.

Section 1. Restrictions on usage

1. This Reference Design is provided solely as reference data for designing electronics applications. Customer shall not use this Reference Design for any other purpose, including without limitation, verification of reliability.
2. Customer shall not use this Reference Design for sale, lease or other transfer.
3. Customer shall not use this Reference Design for evaluation in high or low temperature, high humidity, or high electromagnetic environments.
4. This Reference Design shall not be used for or incorporated into any product or system whose manufacture, use, or sale is prohibited under any applicable laws or regulations.

Section 2. Limitations

1. We reserve the right to make changes to this Reference Design without notice.
2. This Reference Design should be treated as a reference only. WE ARE NOT RESPONSIBLE FOR ANY INCORRECT OR INCOMPLETE DATA AND INFORMATION.
3. Semiconductor devices can malfunction or fail. When designing electronics applications by referring to this Reference Design, Customer is responsible for complying with safety standards and for providing adequate designs and safeguards for their hardware, software and systems which minimize risk and avoid situations in which a malfunction or failure of semiconductor devices could cause loss of human life, bodily injury or damage to property, including data loss or corruption. Customer must also refer to and comply with the latest versions of all relevant our information, including without limitation, specifications, data sheets and application notes for semiconductor devices, as well as the precautions and conditions set forth in the "Semiconductor Reliability Handbook".
4. Designing electronics applications by referring to this Reference Design, Customer must evaluate the whole system sufficiently. Customer is solely responsible for applying this Reference Design to Customer's own product design or applications. WE ASSUME NO LIABILITY FOR CUSTOMER'S PRODUCT DESIGN OR APPLICATIONS.
5. WE SHALL NOT BE RESPONSIBLE FOR ANY INFRINGEMENT OF PATENTS OR ANY OTHER INTELLECTUAL PROPERTY RIGHTS OF THIRD PARTIES THAT MAY RESULT FROM THE USE OF THIS REFERENCE DESIGN. NO LICENSE TO ANY INTELLECTUAL PROPERTY RIGHT IS GRANTED BY THIS TERMS OF USE, WHETHER EXPRESS OR IMPLIED, BY ESTOPPEL OR OTHERWISE.
6. THIS REFERENCE DESIGN IS PROVIDED "AS IS". WE (a) ASSUME NO LIABILITY WHATSOEVER, INCLUDING WITHOUT LIMITATION, INDIRECT, CONSEQUENTIAL, SPECIAL, OR INCIDENTAL DAMAGES OR LOSS, INCLUDING WITHOUT LIMITATION, LOSS OF PROFITS, LOSS OF OPPORTUNITIES, BUSINESS INTERRUPTION AND LOSS OF DATA, AND (b) DISCLAIM ANY AND ALL EXPRESS OR IMPLIED WARRANTIES AND CONDITIONS RELATED TO THIS REFERENCE DESIGN, INCLUDING WITHOUT LIMITATION, WARRANTIES OR CONDITIONS OF FUNCTION AND WORKING, WARRANTIES OF MERCHANTABILITY, FITNESS FOR A PARTICULAR PURPOSE, ACCURACY OF INFORMATION, OR NONINFRINGEMENT.

Section 3. Terms and Termination

It is assumed that Customer agrees to any and all this terms of use if Customer downloads or uses this Reference Design. We may, at its sole and exclusive discretion, change, alter, modify, add, and/or remove any part of this terms of use at any time without any prior notice. We may terminate this terms of use at any time and without any cause. Upon termination of this terms of use, Customer shall eliminate this Reference Design. Furthermore, upon our request, Customer shall submit to us a written confirmation to prove elimination of this Reference Design.

Section 4. Export Control

Customer shall not use or otherwise make available this Reference Design for any military purposes, including without limitation, for the design, development, use, stockpiling or manufacturing of nuclear, chemical, or biological weapons or missile technology products (mass destruction weapons). This Reference Design may be controlled under the applicable export laws and regulations including, without limitation, the Japanese Foreign Exchange and Foreign Trade Act and the U.S. Export Administration Regulations. Export and re-export of this Reference Design is strictly prohibited except in compliance with all applicable export laws and regulations.

Section 5. Governing Laws

This terms of use shall be governed and construed by laws of Japan, without reference to conflict of law principle.

Section 6. Jurisdiction

Unless otherwise specified, Tokyo District Court in Tokyo, Japan shall be exclusively the court of first jurisdiction for all disputes under this terms of use.