

TC78H600FTG

Usage considerations

Summary

The TC78H600FNG is a dual bridge driver.

It can control two DC brush motors by selecting the direct PWM mode and the constant current PWM mode. It can also control one stepping motor by 2-phase excitation or 1-2 phase excitation mode.

Contents

Summary.....	1
1. Power supply voltage and output current.....	4
2. Power dissipation	5
3. Application circuit.....	6
4. Method of driving 2-phase stepping motor by using the TC78H600FNG	9
5. Test of short-circuit.....	10
IC Usage Considerations.....	13
Notes on handling of ICs	13
Points to remember on handling of ICs.....	14
RESTRICTIONS ON PRODUCT USE.....	15

List of Figure

Figure 1 Power dissipation to the ambient temperature.....	5
Figure 2 Application circuit (direct PWM mode)	6
Figure 3 Application circuit (constant current PWM mode)	7
Figure 4 Waveform when the stepping motor is driving	9
Figure 5 Test circuit of the short-circuit test.....	10

List of Table

Table 1 Operating range of power supply voltage and absolute maximum rating.....	4
Table 2 Recommended value of the capacitor for Vcc pin.....	8
Table 3 Recommended value of the capacitor for VM pin	8
Table 4 Result of the test of short-circuit between adjacent terminals.....	11
Table 5 Result of the test of short-circuiting between outputs, air contamination faults, or faults due to improper grounding.....	12

1. Power supply voltage and output current

(1) Operating range of power supply voltage

Table 1 Operating range of power supply voltage and absolute maximum rating

Characteristics	Symbol	Operating voltage range	Absolute maximum rating	Unit
Power supply voltage	V_{CC}	2.7 to 5.5	6	V
Motor power supply voltage	V_M	2.5 to 15	18	V

Note: The absolute maximum ratings of a semiconductor device are a set of ratings that must not be exceeded, even for a moment.
Please use the IC within the specified operating ranges.

(2) Power on/Shutdown sequence

In applying V_{CC} or shutdown, set $STBY=L$ or $IN1A=IN2A=IN1B=IN2B=L$. If $STBY$ is configured high or any of $IN1A$, $IN2A$, $IN1B$, or $IN2B$ is configured high in applying V_{CC} or shutdown, unexpected current may flow in the output terminals.

(3) Output current

The absolute maximum rating is 1.0 A (peak). The absolute maximum ratings of a semiconductor device are a set of ratings that must not be exceeded, even for a moment.

The average permissible current is restricted by total power dissipation. Please use the IC within the range of the power dissipation.

2. Power dissipation

The relation of the ambient temperature and the power dissipation in each mounting condition is shown below. (The upper limit of the ambient temperature in operation is 85°C)

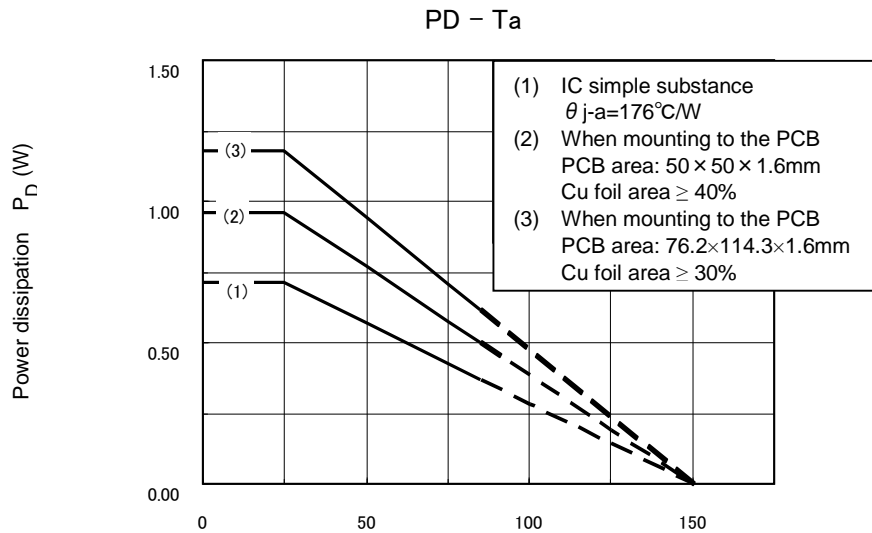

Figure 1 Power dissipation to the ambient temperature

The example of calculation of power consumption is as follows;

When I_{out} is 0.2A, the output saturated voltage ($V_{SAT(U+L)}$) is 0.32V (max).

When V_{CC} is 3.3V, the consumption current (I_{CC2}) is 6mA (max). When V_M is 5V, the consumption current (I_{M2}) is 1mA (max).

Output duty is 100%. Output part is doubled because of double phases.

$$\begin{aligned}
 P_D &= (I_{out} \times (\text{duty}) \times V_{SAT(U+L)}) \times 2 + V_{CC} \times I_{CC2} + V_M \times I_{M2} \\
 &= 0.2 \times 100\% \times 0.32 \times 2 + 3.3 \times 0.006 + 5 \times 0.001 \\
 &= 0.15\text{W}
 \end{aligned}$$

The heat characteristic changes largely depending on the radiation characteristics of the board and the transient property of the mounting condition. So, please check it under the condition of actual operation.

3. Application circuit

[1] Direct PWM mode: SELECT=L

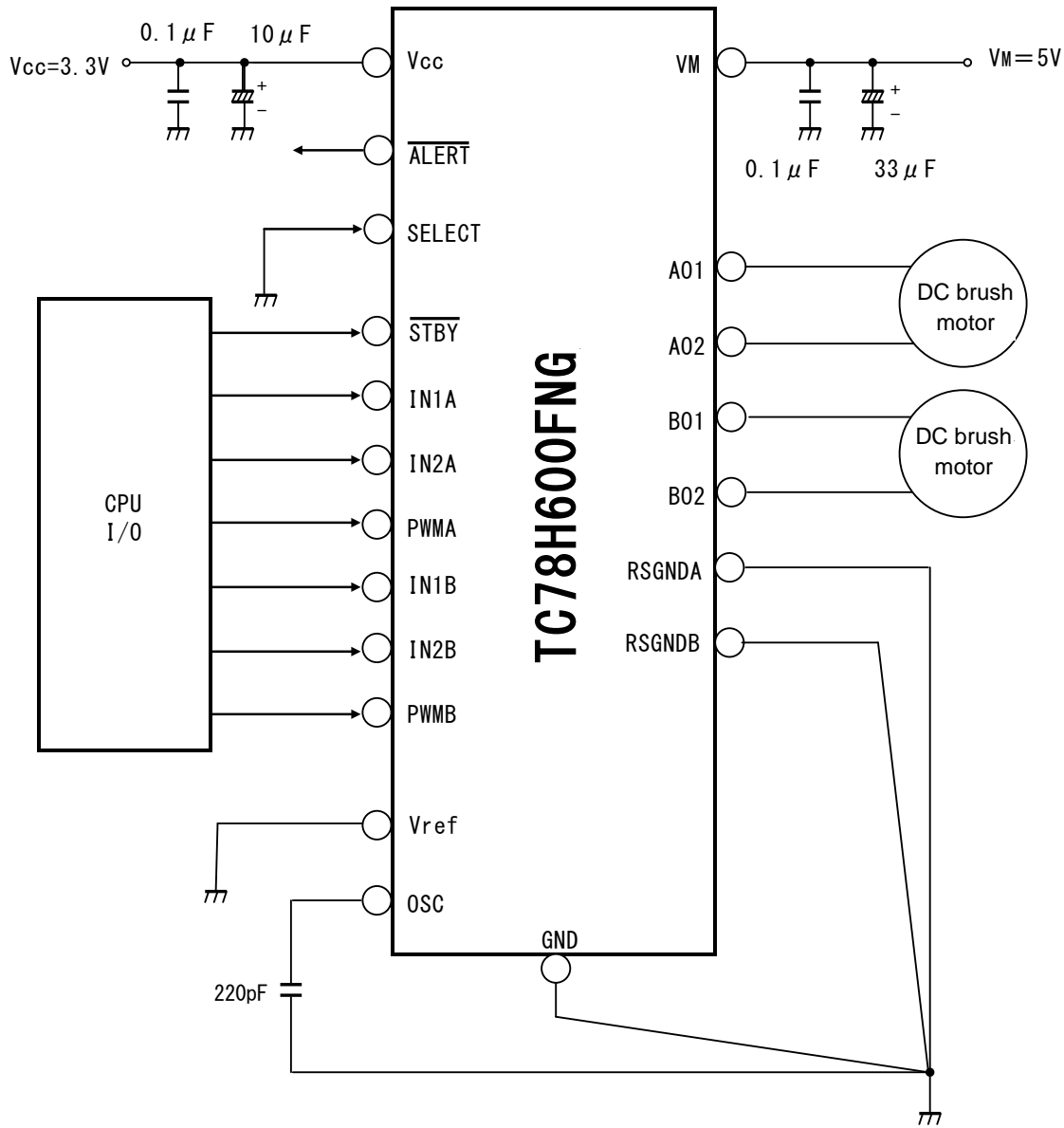

- Connect RSGNDA, RSGNDB, and Vref to GND.

Figure 2 Application circuit (direct PWM mode)

[2] Constant PWM: ELECT=H

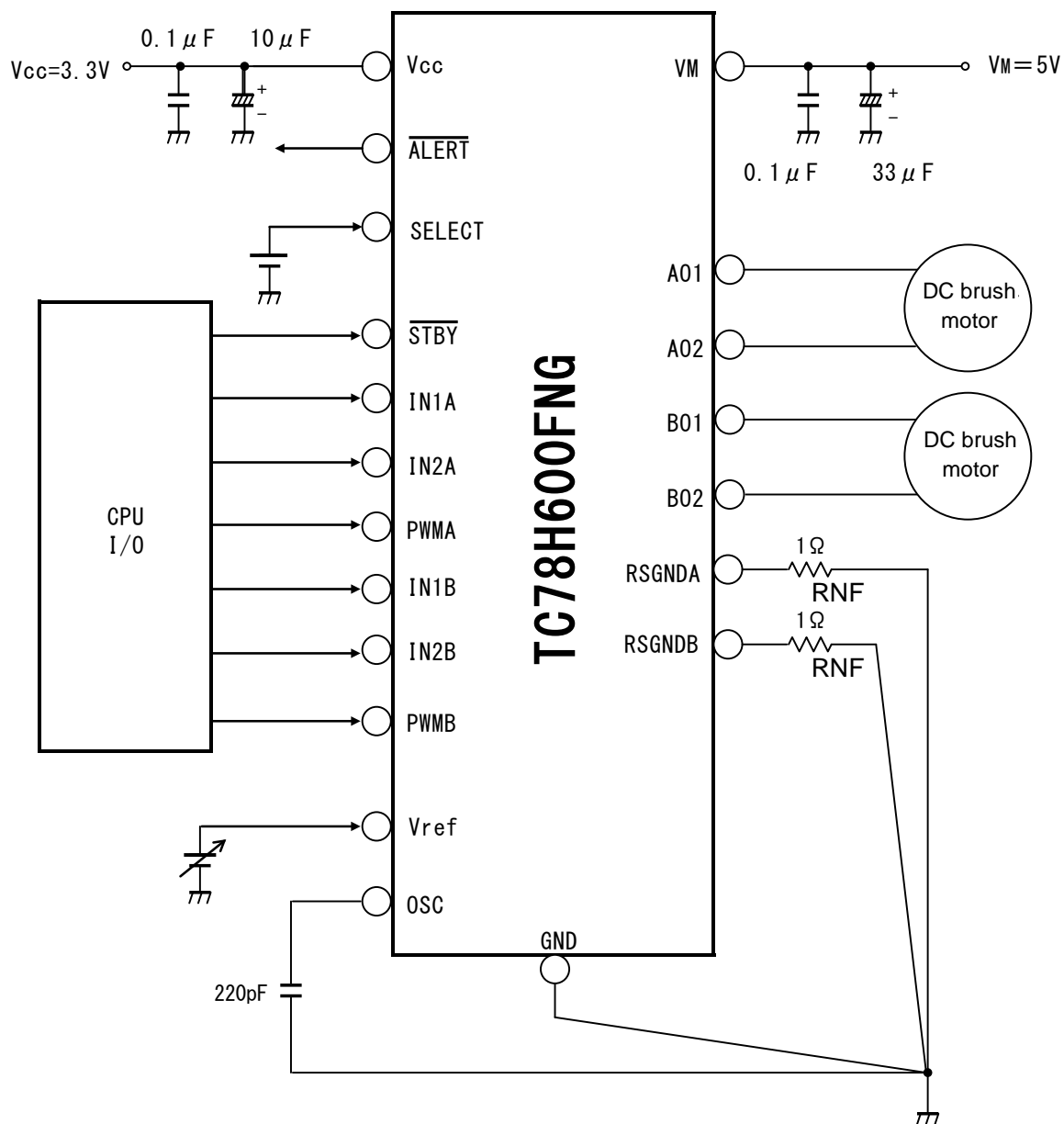

- Connect the current detection resistance (RNF) to RSGNDA and RSGNDB.

Figure 3 Application circuit (constant current PWM mode)

Setting of output current is as follows;

$$I_{out} (A) = (1/5 \times V_{ref} (V)) \div R_{NF} (\Omega)$$

Condition: The torque setting is 100% (TQ=H)

Example) When the torque setting is 100 % (TQ=H), V_{ref} is 2.5V, and the maximum current is 0.5A, the external resistance is 1.0 Ω . Then when the torque setting changes 25% (TQ=L) under this condition, the maximum current is 0.125 A.

V_{ref} should be configured in the range of 0.4V to 3.4V and $V_{CC} - 1.8V$ or less. If it is configured less than 0.4V, the accuracy of the operation is decreased.

Use the IC by connecting the resistance (R_{NF}) of 0.3 Ω or more.

The following (1) to (3) describe [1] Direct PWM mode and [2] Constant current PWM mode in common.

(1) **Capacitor for power supply voltage terminal**

Capacitors between V_{CC} and GND should be connected as close to the IC as possible.

Table 2 Recommended value of the capacitor for V_{CC} pin

Item	Recommended value	Remarks
Between V_{CC} and GND	10 μ F to 100 μ F	Electrolytic capacitor
	0.1 μ F to 1 μ F	Ceramic capacitor

(2) **Capacitor for V_M terminal**

Capacitors between V_M and GND should be connected as close to the IC as possible.

Table 3 Recommended value of the capacitor for V_M pin

Item	Recommended value	Remarks
Between V_M and GND	10 μ F to 100 μ F	Electrolytic capacitor
	0.1 μ F to 1 μ F	Ceramic capacitor

(3) **Capacitor for OSC terminal**

The internal oscillation frequency is determined by the capacitor of OSC terminal. When C_{OSC} is 220 pF, the oscillation frequency is 320 kHz (typ.).

4. Method of driving 2-phase stepping motor by using the TC78H600FNG

Two-phase stepping motor can be driven as shown in the below input signal waveform.

Iout: The current direction is defined as follows;

AO1→AO2 (or BO1→BO2): Plus current

AO2→AO1 (or BO2→BO1): Minus current *STBY=H, PWMA=PWMB=H

(1) Excitation mode: 2-phase excitation

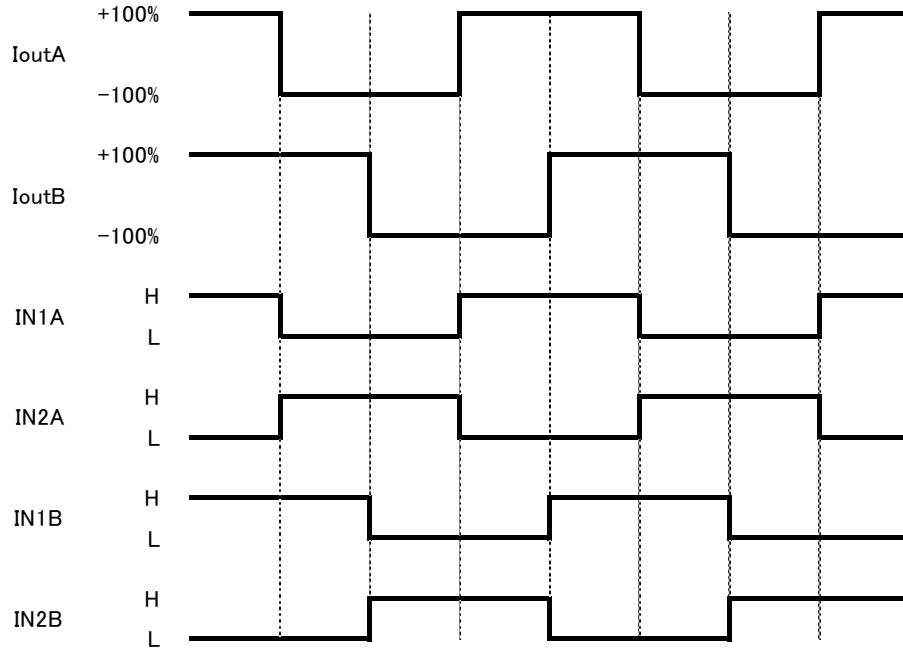

(2) Excitation mode: 1-2-phase excitation

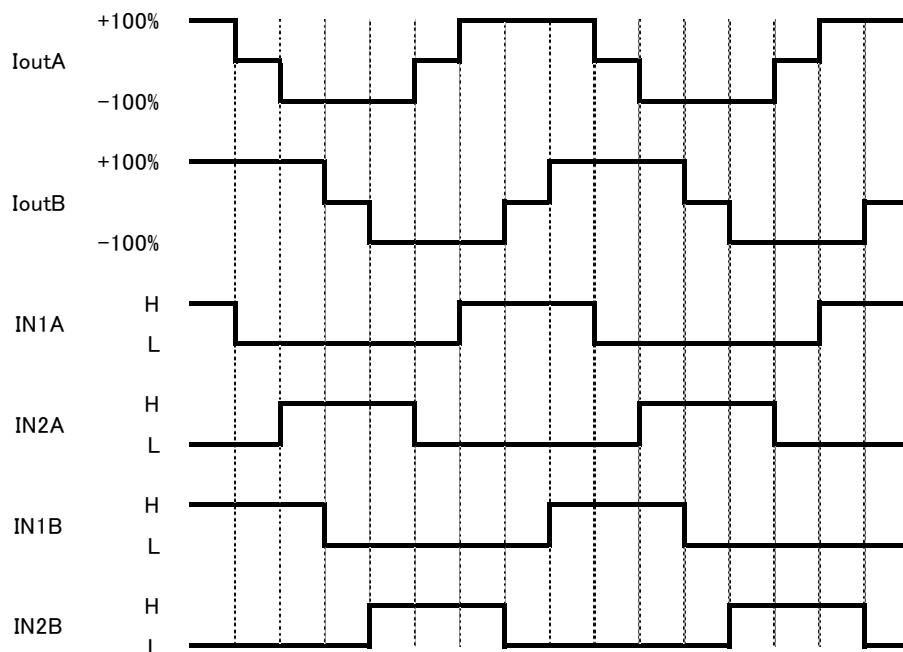

Figure 4 Waveform when the stepping motor is driving

5. Test of short-circuit

Test of short-circuit between outputs, air contamination faults, or faults due to improper grounding

Test conditions: $V_{cc}=5V$, $V_M=12V$, $V_{ref}=1V$, $R_{SGNDA}=R_{SGNDB}=1.5\Omega$, $OSC=220pF$, $STBY=SELECT=IN1A=IN2A=PWMA=IN1B=IN2B=PWMB=H$, Motor load (The resistance of $1k\Omega$ is adopted between $IN1B$ terminal and V_{cc} . between $PWMB$ terminal and V_{cc} , and between $SELECT$ terminal and V_{cc} to reduce the IC destruction.)

Test circuit

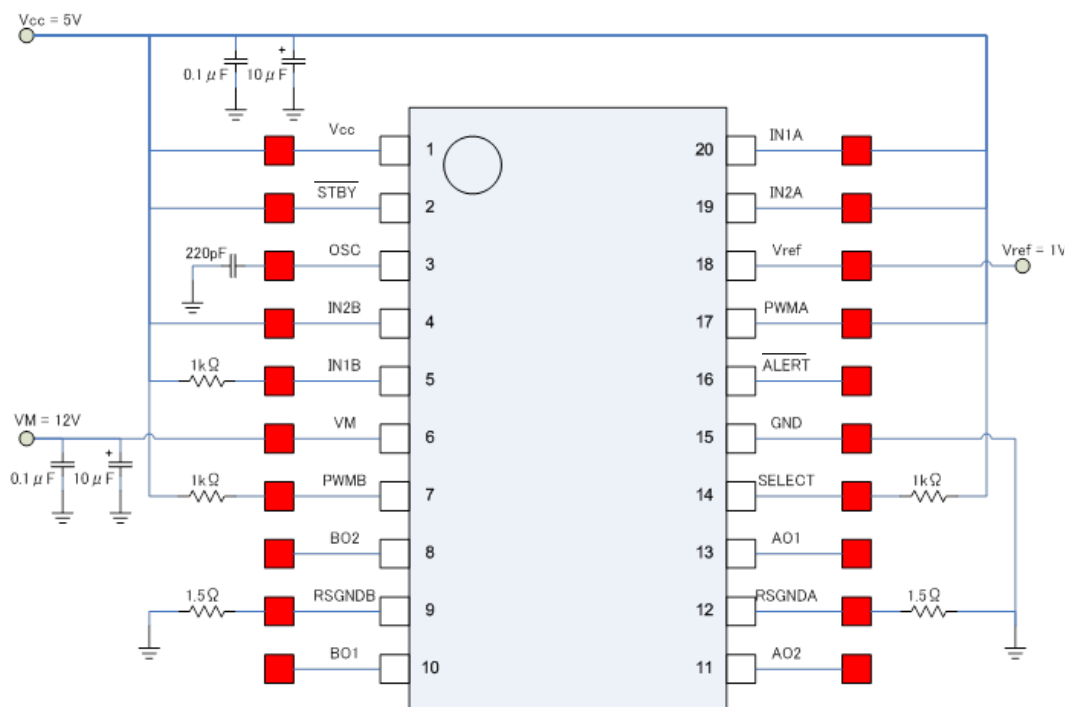

Figure 5 Test circuit of the short-circuit test

(1) Test of short-circuit between adjacent terminals

Table 4 Result of the test of short-circuit between adjacent terminals

Pin No.	Pin name	Result	Judgment
1	VCC	Normal appearance, no smoke, normal operation after test	Pass
2	STBY		
3	OSC	Normal appearance, no smoke, normal operation after test	Pass
4	IN2B	Normal appearance, no smoke, normal operation after test	Pass
5	IN1B	Normal appearance, no smoke. Changing excitation mode by IN1B pin after test is impossible. Pin is destroyed by round over voltage (12V) from the VM pin.	Pass
6	VM		
7	PWMB	Normal appearance, no smoke, normal operation after test	Pass
8	BO2	Normal appearance, no smoke, normal operation after test	Pass
9	RSGNDB		
10	BO1	Normal appearance, no smoke, normal operation after test	Pass
11	AO2		
12	RSGNDA	Normal appearance, no smoke, normal operation after test	Pass
13	AO1		
14	SELECT	Normal appearance, no smoke, normal operation after test	Pass
15	GND		
16	ALEART	Normal appearance, no smoke, normal operation after test	Pass
17	PWMA		
18	Vref	Normal appearance, no smoke, normal operation after test	Pass
19	IN2A		
20	IN1A	Normal appearance, no smoke, normal operation after test	Pass

- (2) Test of short-circuiting between outputs, air contamination faults, or faults due to improper grounding
 Test of short-circuiting between outputs, air contamination faults, or faults due to improper grounding. The results of the test are shown below. There is no problem.

Test conditions: VCC=5V, VM=12V, Vref=1V, RSGNDA=RSGNDB=1.5Ω, Cosc=220pF
 STBY= SELECT= IN1A=IN2A=PWMA=IN1B=IN2B=PWMB= High (VCC),
 Motor load

Table 5 Result of the test of short-circuiting between outputs, air contamination faults, or faults due to improper grounding

Terminal	Result	Judgment
AO1 ⇔ AO2	Normal appearance, no smoke, normal operation after test	Pass
AO1 ⇔ VM	Normal appearance, no smoke, normal operation after test	Pass
AO1 ⇔ GND	Normal appearance, no smoke, normal operation after test	Pass
AO2 ⇔ VM	Normal appearance, no smoke, normal operation after test	Pass
AO2 ⇔ GND	Normal appearance, no smoke, normal operation after test	Pass
BO1 ⇔ BO2	Normal appearance, no smoke, normal operation after test	Pass
BO1 ⇔ VM	Normal appearance, no smoke, normal operation after test	Pass
BO1 ⇔ GND	Normal appearance, no smoke, normal operation after test	Pass
BO2 ⇔ VM	Normal appearance, no smoke, normal operation after test	Pass
BO2 ⇔ GND	Normal appearance, no smoke, normal operation after test	Pass

ISD (over current detection) enables.

Notes on Contents

1. Block diagram
Some of the functional blocks, circuits, or constants in the block diagram may be omitted or simplified for explanatory purposes.
2. Equivalent Circuits
The equivalent circuit diagrams may be simplified or some parts of them may be omitted for explanatory purposes.
3. Timing Charts
Timing charts may be simplified for explanatory purposes.
4. Application Circuit
The application circuits shown in this document are provided for reference purposes only. Thorough evaluation is required, especially at the mass production design stage. Toshiba does not grant any license to any industrial property rights by providing these examples of application circuits.
5. Test Circuit
Components in the test circuits are used only to obtain and confirm the device characteristics. These components and circuits are not guaranteed to prevent malfunction or failure from occurring in the application equipment.

IC Usage Considerations**Notes on handling of ICs**

- (1) The absolute maximum ratings of a semiconductor device are a set of ratings that must not be exceeded, even for a moment. Do not exceed any of these ratings. Exceeding the rating(s) may cause device breakdown, damage or deterioration, and may result in injury by explosion or combustion.
- (2) Use an appropriate power supply fuse to ensure that a large current does not continuously flow in case of over current and/or IC failure. The IC will fully break down when used under conditions that exceed its absolute maximum ratings, when the wiring is routed improperly or when an abnormal pulse noise occurs from the wiring or load, causing a large current to continuously flow and the breakdown can lead smoke or ignition. To minimize the effects of the flow of a large current in case of breakdown, appropriate settings, such as fuse capacity, fusing time and insertion circuit location, are required.
- (3) If your design includes an inductive load such as a motor coil, incorporate a protection circuit into the design to prevent device malfunction or breakdown caused by the current resulting from the inrush current at power ON or the negative current resulting from the back electromotive force at power OFF. IC breakdown may cause injury, smoke or ignition. Use a stable power supply with ICs with built-in protection functions. If the power supply is unstable, the protection function may not operate, causing IC breakdown. IC breakdown may cause injury, smoke or ignition.
- (4) Do not insert devices in the wrong orientation or incorrectly. Make sure that the positive and negative terminals of power supplies are connected properly. Otherwise, the current or power consumption may exceed the absolute maximum rating, and exceeding the rating(s) may cause the device breakdown, damage or deterioration, and may result injury by explosion or combustion. In addition, do not use any device that is applied the current with inserting in the wrong orientation or incorrectly even just one time.

Points to remember on handling of ICs

- (1) **Over current Protection Circuit**
Over current protection circuits (referred to as current limiter circuits) do not necessarily protect ICs under all circumstances. If the over current protection circuits operate against the over current, clear the over current status immediately.
Depending on the method of use and usage conditions, such as exceeding absolute maximum ratings can cause the over current protection circuit to not operate properly or IC breakdown before operation. In addition, depending on the method of use and usage conditions, if over current continues to flow for a long time after operation, the IC may generate heat resulting in breakdown.

- (2) **Thermal Shutdown Circuit**
Thermal shutdown circuits do not necessarily protect ICs under all circumstances. If the thermal shutdown circuits operate against the over temperature, clear the heat generation status immediately.
Depending on the method of use and usage conditions, such as exceeding absolute maximum ratings can cause the thermal shutdown circuit to not operate properly or IC breakdown before operation.

- (3) **Heat Radiation Design**
In using an IC with large current flow such as power amp, regulator or driver, please design the device so that heat is appropriately radiated, not to exceed the specified junction temperature (T_j) at any time and condition. These ICs generate heat even during normal use. An inadequate IC heat radiation design can lead to decrease in IC life, deterioration of IC characteristics or IC breakdown. In addition, please design the device taking into consideration the effect of IC heat radiation with peripheral components.

- (4) **Back-EMF**
When a motor rotates in the reverse direction, stops or slows down abruptly, a current flow back to the motor's power supply due to the effect of back-EMF. If the current sink capability of the power supply is small, the device's motor power supply and output pins might be exposed to conditions beyond absolute maximum ratings. To avoid this problem, take the effect of back-EMF into consideration in system design.

RESTRICTIONS ON PRODUCT USE

- Toshiba Corporation, and its subsidiaries and affiliates (collectively "TOSHIBA"), reserve the right to make changes to the information in this document, and related hardware, software and systems (collectively "Product") without notice.
- This document and any information herein may not be reproduced without prior written permission from TOSHIBA. Even with TOSHIBA's written permission, reproduction is permissible only if reproduction is without alteration/omission.
- Though TOSHIBA works continually to improve Product's quality and reliability, Product can malfunction or fail. Customers are responsible for complying with safety standards and for providing adequate designs and safeguards for their hardware, software and systems which minimize risk and avoid situations in which a malfunction or failure of Product could cause loss of human life, bodily injury or damage to property, including data loss or corruption. Before customers use the Product, create designs including the Product, or incorporate the Product into their own applications, customers must also refer to and comply with (a) the latest versions of all relevant TOSHIBA information, including without limitation, this document, the specifications, the data sheets and application notes for Product and the precautions and conditions set forth in the "TOSHIBA Semiconductor Reliability Handbook" and (b) the instructions for the application with which the Product will be used with or for. Customers are solely responsible for all aspects of their own product design or applications, including but not limited to (a) determining the appropriateness of the use of this Product in such design or applications; (b) evaluating and determining the applicability of any information contained in this document, or in charts, diagrams, programs, algorithms, sample application circuits, or any other referenced documents; and (c) validating all operating parameters for such designs and applications. **TOSHIBA ASSUMES NO LIABILITY FOR CUSTOMERS' PRODUCT DESIGN OR APPLICATIONS.**
- **PRODUCT IS NEITHER INTENDED NOR WARRANTED FOR USE IN EQUIPMENTS OR SYSTEMS THAT REQUIRE EXTRAORDINARILY HIGH LEVELS OF QUALITY AND/OR RELIABILITY, AND/OR A MALFUNCTION OR FAILURE OF WHICH MAY CAUSE LOSS OF HUMAN LIFE, BODILY INJURY, SERIOUS PROPERTY DAMAGE AND/OR SERIOUS PUBLIC IMPACT ("UNINTENDED USE").** Except for specific applications as expressly stated in this document, Unintended Use includes, without limitation, equipment used in nuclear facilities, equipment used in the aerospace industry, medical equipment, equipment used for automobiles, trains, ships and other transportation, traffic signaling equipment, equipment used to control combustions or explosions, safety devices, elevators and escalators, devices related to electric power, and equipment used in finance-related fields. **IF YOU USE PRODUCT FOR UNINTENDED USE, TOSHIBA ASSUMES NO LIABILITY FOR PRODUCT.** For details, please contact your TOSHIBA sales representative.
- Do not disassemble, analyze, reverse-engineer, alter, modify, translate or copy Product, whether in whole or in part.
- Product shall not be used for or incorporated into any products or systems whose manufacture, use, or sale is prohibited under any applicable laws or regulations.
- The information contained herein is presented only as guidance for Product use. No responsibility is assumed by TOSHIBA for any infringement of patents or any other intellectual property rights of third parties that may result from the use of Product. No license to any intellectual property right is granted by this document, whether express or implied, by estoppel or otherwise.
- **ABSENT A WRITTEN SIGNED AGREEMENT, EXCEPT AS PROVIDED IN THE RELEVANT TERMS AND CONDITIONS OF SALE FOR PRODUCT, AND TO THE MAXIMUM EXTENT ALLOWABLE BY LAW, TOSHIBA (1) ASSUMES NO LIABILITY WHATSOEVER, INCLUDING WITHOUT LIMITATION, INDIRECT, CONSEQUENTIAL, SPECIAL, OR INCIDENTAL DAMAGES OR LOSS, INCLUDING WITHOUT LIMITATION, LOSS OF PROFITS, LOSS OF OPPORTUNITIES, BUSINESS INTERRUPTION AND LOSS OF DATA, AND (2) DISCLAIMS ANY AND ALL EXPRESS OR IMPLIED WARRANTIES AND CONDITIONS RELATED TO SALE, USE OF PRODUCT, OR INFORMATION, INCLUDING WARRANTIES OR CONDITIONS OF MERCHANTABILITY, FITNESS FOR A PARTICULAR PURPOSE, ACCURACY OF INFORMATION, OR NONINFRINGEMENT.**
- Do not use or otherwise make available Product or related software or technology for any military purposes, including without limitation, for the design, development, use, stockpiling or manufacturing of nuclear, chemical, or biological weapons or missile technology products (mass destruction weapons). Product and related software and technology may be controlled under the applicable export laws and regulations including, without limitation, the Japanese Foreign Exchange and Foreign Trade Law and the U.S. Export Administration Regulations. Export and re-export of Product or related software or technology are strictly prohibited except in compliance with all applicable export laws and regulations.
- Please contact your TOSHIBA sales representative for details as to environmental matters such as the RoHS compatibility of Product. Please use Product in compliance with all applicable laws and regulations that regulate the inclusion or use of controlled substances, including without limitation, the EU RoHS Directive. **TOSHIBA ASSUMES NO LIABILITY FOR DAMAGES OR LOSSES OCCURRING AS A RESULT OF NONCOMPLIANCE WITH APPLICABLE LAWS AND REGULATIONS.**