

TB62214AFTG Usage Considerations

This document includes application circuit examples and IC usage considerations for motor driver evaluation purposes. Please note that some expressions in this document is not officially guaranteed. Please see the datasheet for more specification.

1. Power supply

1.1 Operating ranges (VM power supply)

The absolute maximum voltage is rated at 40V; but please remind to use the IC between 10V ~ 38V (operating range).

1.2 Power-on and power-off sequence

Before applying the VM power supply, please check that the RESET pin is set to High level, and the ENABLE pin to the Low level. Also, please set both pins as shown above, when cutting the VM power supply off. The TB62214AFTG has an internal voltage monitor circuit to avoid missfunction during power-on; but to be certain, please set the RESET to High and ENABLE to Low during power-on and power-off sequence.

When the control signal is applied while VM power supply is off:

The TB62214AFTG is designed to not missfunction when the control signal is applied and the VM power supply is off. But, this content is not tested, therefore is not officially guaranteed.

The TB62214AFTG has an internal VM voltage monitor circuit (Power-on-reset also known as Under Voltage Lockout circuit) which will monitor the supplied voltage; when the VM reaches above the VM POR threshold, the device becomes active, and when the VM is below the VM POR threshold, the device will go to OFF(reset) mode.

If the control signal is applied before the VM power is supplied; when the VM level reaches above the VM POR threshold, the internal logic will become active, which will then start to function before the VM level reaches the proper operating range. Also, the same situation will occur while power-off sequence. Therefore please apply the control signal after the VM power level sets to the proper operating range to avoid causing missfunction. The timing chart shown below is an example for the power-on and power-off sequence.

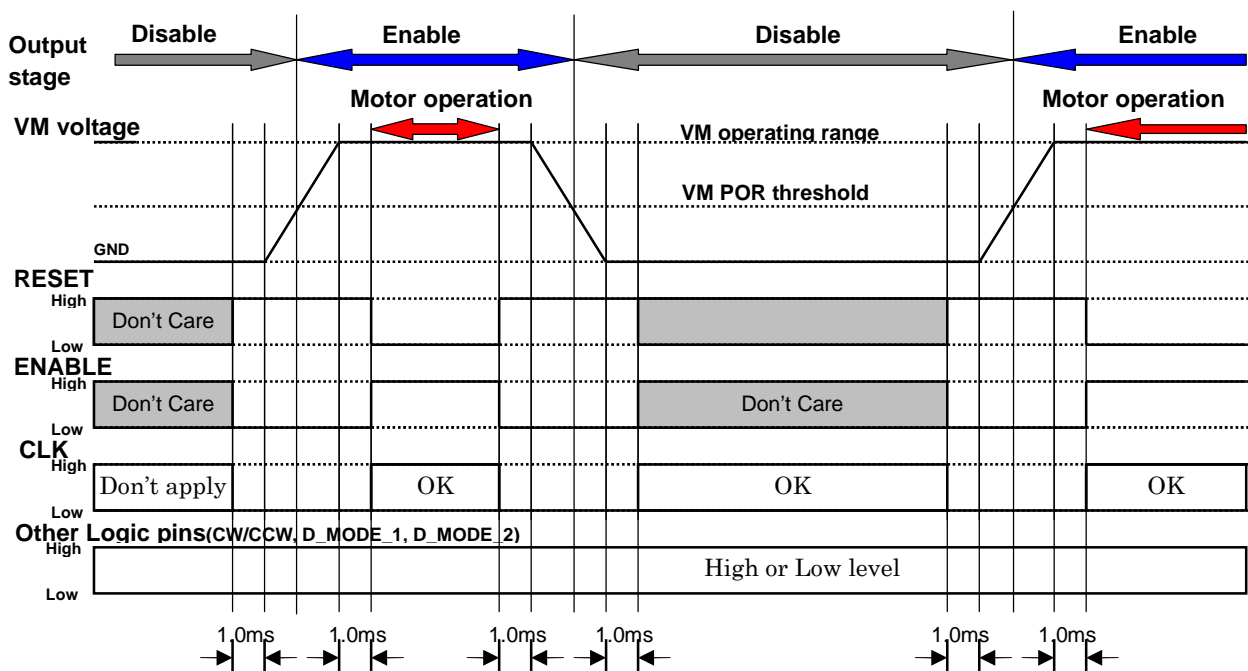

When the VM voltage level decreases while operation:

If the VM voltage level drops below the VM POR threshold, the output stage will be turned off. Please set the VM voltage to the proper operating level to restart the motor function.

Also, if the VM level decreases, but does not reach below the VM POR threshold; it is possible that the motor may malfunction due to the voltage drop, but the output stage will stay "ON".

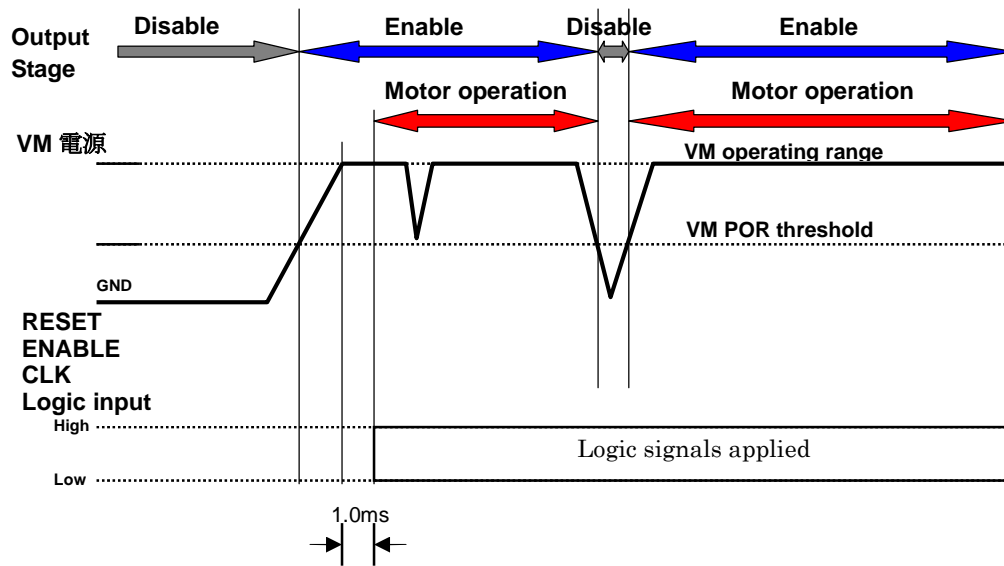

Characteristics	Symbol	Test condition	Min	Typ	Max	Unit
VM POR threshold	V_{MR}	$T_a = 25^\circ\text{C}, V_M = 24\text{ V}$	7.0	8.0	9.0	V

2. Output current

2.1 Output current error relative to the predetermined value

Characteristics	Symbol	Test Condition	Min	Typ.	Max	Unit
Channel-to-channel differential	ΔI_{OUT1}	Channel-to-channel error	-5	0	5	%
Output current error relative to the predetermined value	ΔI_{OUT2}	$I_{OUT}=1.0A$	-5	0	5	%

The ΔI_{OUT2} is tested at 1.0A and 0.4A(motor current). The current precision between $I_{out}=0.4\sim 1.0A$ is not an outgoing test characteristics; therefore is not officially guaranteed.

2.2 OSC_M oscillation frequency , Chopper frequency range

$T_a = 25^\circ C, V_M = 24 V, 6.8 mH/5.7 \Omega$

Characteristics	Symbol	Test Condition	Min	Typ.	Max	Unit
OSC_M oscillation frequency	f_{CR}	$C_{osc}= 270 pF, R_{osc} =3.6 k\Omega$	1200	1600	2000	kHz
Chopper frequency range	$f_{chop(RANGE)}$	$V_M=24 V,$ 出力 ACTIVE ($I_{OUT}=1.0 A$)	40	100	150	kHz
Chopper setting frequency	f_{chop}	出力 ACTIVE ($I_{OUT} =1.0 A$), CR= 1600 kHz	-	100	-	kHz

During normal operation, 1 PWM cycle will contain “Charge”, ”Slow”, and “Fast” operation status. If the motor current level does not reach the current feedback threshold during 1 PWM cycle, the output stage will remain at “Charge” operation until the motor current reached the threshold level. (Please keep in mind that in this case, the chopper setting frequency may seem to operate at half the speed.)

3. Application circuit examples

3.1 Application circuit example (Setting the current threshold with an external Vref voltage)

The value of the external components shown below are some examples for evaluation. Please see the datasheet for more specific data.

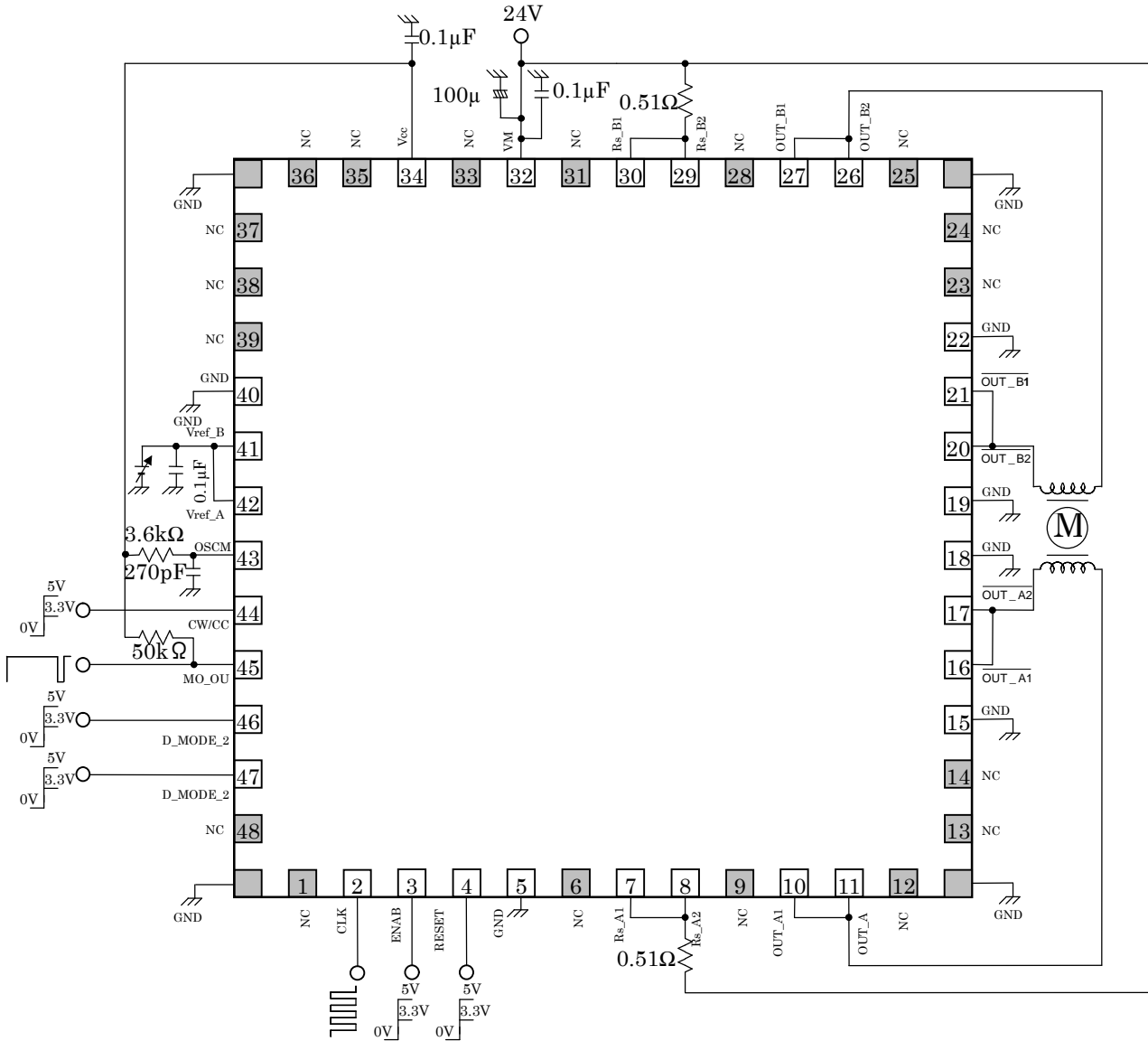

Note: Bypass capacitors should be added as necessary.

It is recommended to use a single ground plane for the entire board whenever possible, and a grounding method should be considered for efficient heat dissipation.

In cases where mode setting pins are controlled via switches, either pull-down or pull-up resistors should be added to them to avoid floating states.

For a description of the input values, see the function tables.

The above application circuit example is presented only as a guide and should be fully evaluated prior to production. Also, no intellectual property right is ceded in any way whatsoever in regard to its use.

The external components in the above diagram are used to test the electrical characteristics of the device: it is not guaranteed that no system malfunction or failure will occur.

3.2 Application Circuit example(Setting the current threshold level using the internal VCC voltage)

The value of the external components shown below are some examples for evaluation. Please see the datasheet for more specific data.

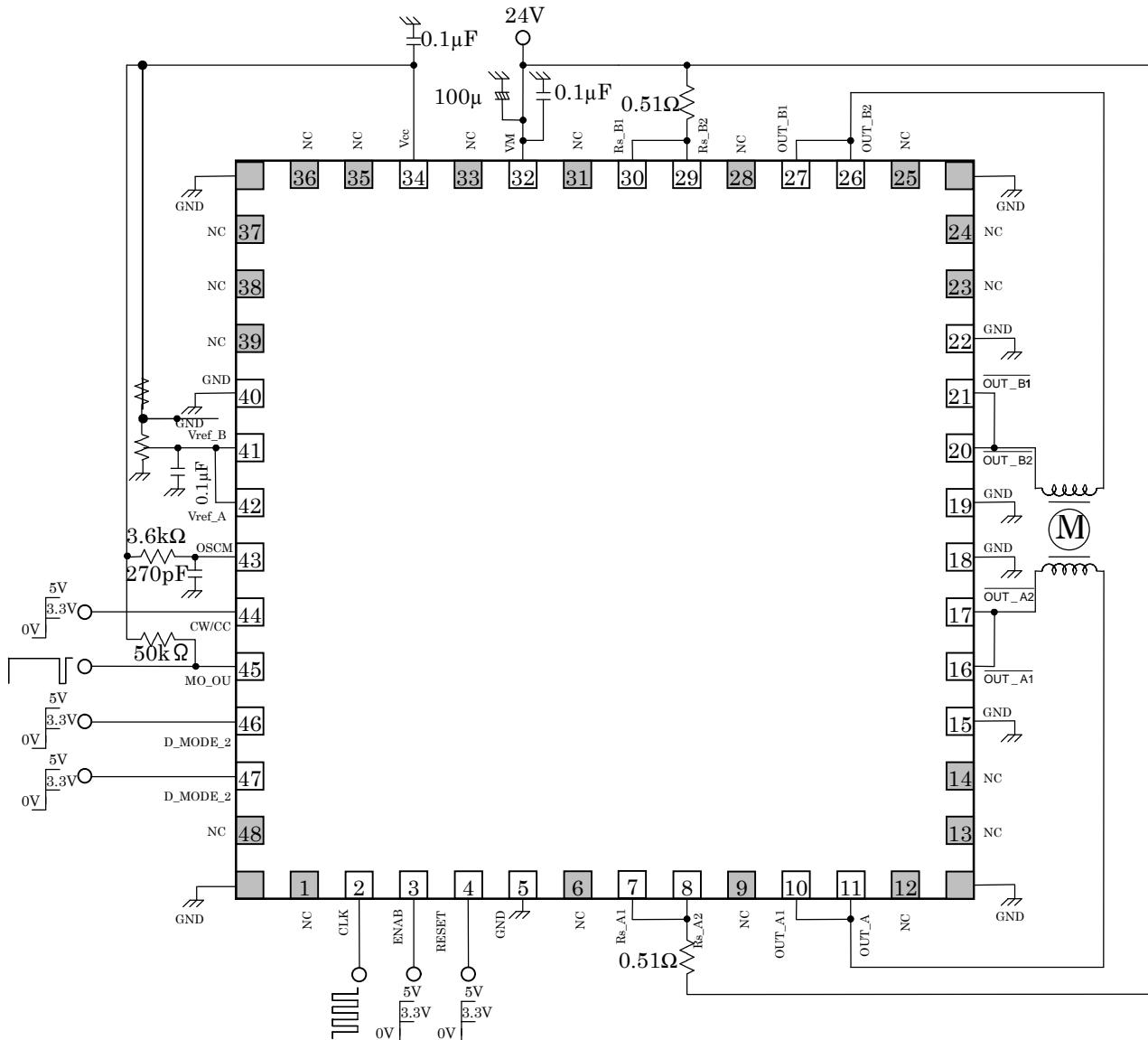

Note: Bypass capacitors should be added as necessary.

Careful attention should be paid to the layout of the output, V_{DD} (V_M) and GND traces to avoid short-circuits across output pins or to the power supply or ground. If such a short-circuit occurs, the TB62214AFTG may be permanently damaged. Also, if the device is installed in a wrong orientation, a high voltage might be applied to components with lower voltage ratings, causing them to be damaged. The TB62214AFTG does not have an overvoltage protection circuit. Thus, if a voltage exceeding the rated maximum voltage is applied, the TB62214AFTG will be damaged; it should be ensured that it is used within the specified operating conditions.

It is recommended to use a single ground plane for the entire board whenever possible, and a grounding method should be considered for efficient heat dissipation.

In cases where mode setting pins are controlled via switches, either pull-down or pull-up resistors should be

Careful attention should be paid to the layout of the output, V_{DD} (V_M) and GND traces to avoid short-circuits across output pins or to the power supply or ground. If such a short-circuit occurs, the TB62214AFTG may be permanently damaged. Also, if the device is installed in a wrong orientation, a high voltage might be applied to components with lower voltage ratings, causing them to be damaged. The TB62214AFTG does not have an overvoltage protection circuit. Thus, if a voltage exceeding the rated maximum voltage is applied, the TB62214AFTG will be damaged; it should be ensured that it is used within the specified operating conditions.

added to them to avoid floating states.

For a description of the input values, see the function tables.

The above application circuit example is presented only as a guide and should be fully evaluated prior to production. Also, no intellectual property right is ceded in any way whatsoever in regard to its use.

The external components in the above diagram are used to test the electrical characteristics of the device: it is not guaranteed that no system malfunction or failure will occur.

4. $P_D - T_a$ (package power dissipation)

When mounted on a special glass-epoxy four-layer board for QFN48-P-0707-0.5

(4 layer board, 1st, 4th layer Cu thickness: 55 μ m, 2nd, 3rd layer: 35 μ m, Size: 100 mm \times 110 mm \times 1.6 mm, $\theta(j-a) = 30$ [$^{\circ}$ C/W]: typ. $\theta(j-c) = 3.0$ [$^{\circ}$ C/W])

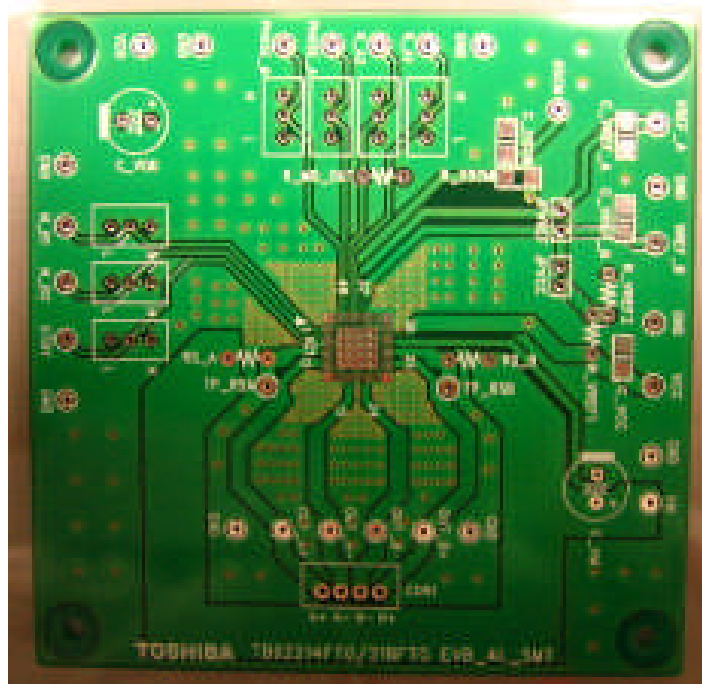
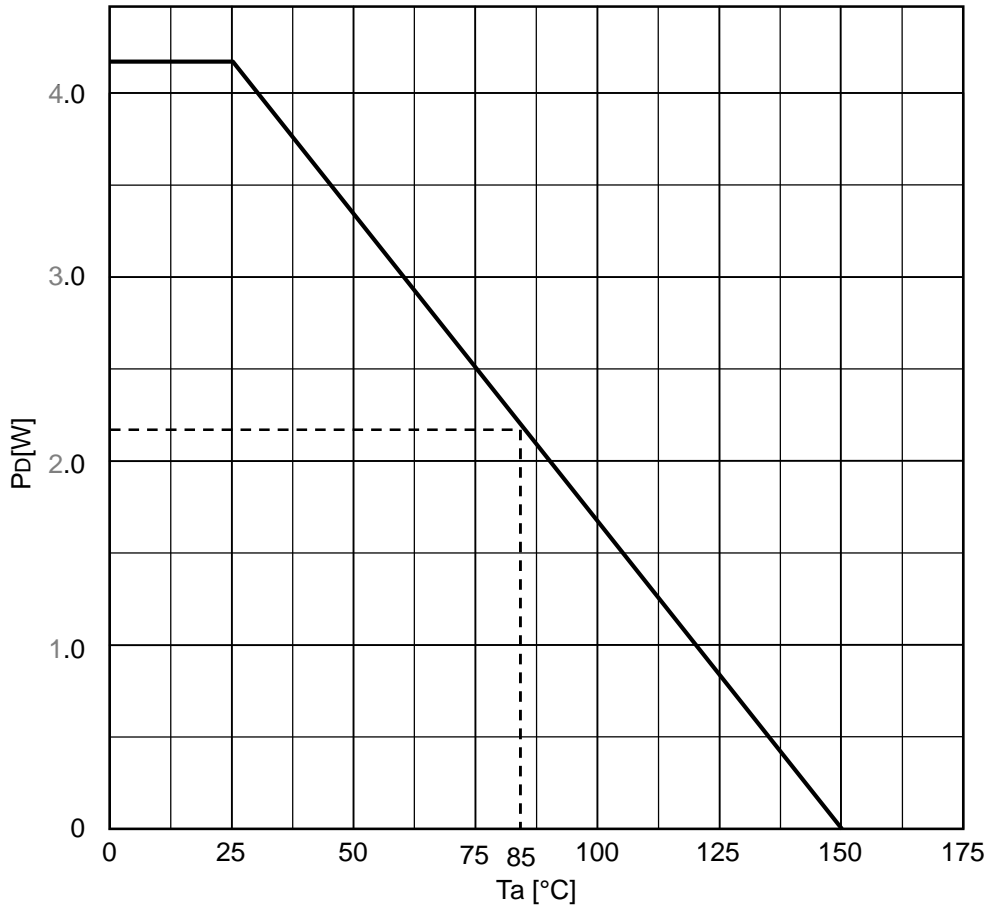

【Glass-epoxy four-layer board for QFN48-P-0707-0.5】

5. IC Power Consumption

The power consumed by the TB62214FG/FTG is approximately the sum of the following two: 1) the power consumed by the output transistors, and 2) the power consumed by the digital logic and pre-drivers.

- The power consumed by the output transistors is calculated, using the R_{ON} (D-S) value of 1.0Ω .
- Whether in Charge, Fast Decay or Slow Decay mode, two of the four transistors comprising each H-bridge contribute to its power consumption at a given time.

Thus the power consumed by each H-bridge is given by:

$$P(\text{out}) = I_{\text{OUT}}(\text{A}) \times V_{\text{DS}}(\text{V}) = I_{\text{OUT}}^2 \times R_{\text{ON}}$$

The power consumption in the I_M domain is calculated separately for normal operation and standby modes:

$$I(I_{M3}) = 5.0 \text{ mA (typ.): Normal operation mode.}$$

$$I(I_{M1}) = 2.0 \text{ mA (typ.): Standby mode.}$$

The current consumed in the digital logic portion of the TB62214AFTG is indicated as I_{max} . The digital logic operates off a voltage regulator that is internally connected to the V_M power supply. It consists of the digital logic connected to V_M (24 V) and the network affected by the switching of the output transistors. The total power consumed by I_{Mx} can be estimated as:

$$P(I_{M3}) = 24(\text{V}) \times 0.005(\text{A}) = 0.12(\text{W})$$

$$P(I_{M1}) = 24(\text{V}) \times 0.002(\text{A}) = 0.048(\text{W})$$

Hence, the total power consumption of the TB62214AFTG is:

$$P = P(\text{out}) + P(I_{M3}) = P(\text{out}) + 0.12(\text{W})$$

The standby power consumption is given by:

$$P = P(I_{M1}) = 0.048(\text{W})$$

5.1 Heat radiation design

While considering the heat calculation of eval boards please perform mounting evaluation enough.

In using an IC with large current flow such as power amp, regulator or driver, please design the device so that heat is appropriately radiated, not to exceed the specified junction temperature (T_J) at any time and condition. Please remind to keep the device below $T_a=150^\circ\text{C}$.

$$T_J = P \times R_{\text{th}(j-a)} + T_a$$

※ : $R_{\text{th}(j-a)}$: junction- T_a heat resistance

※ : T_a : Ambient temperature

Please note that the $R_{\text{th}(j-a)}$ will be effected due to the circumstances around the device.

RESTRICTIONS ON PRODUCT USE

- Toshiba Corporation, and its subsidiaries and affiliates (collectively "TOSHIBA"), reserve the right to make changes to the information in this document, and related hardware, software and systems (collectively "Product") without notice.
- This document and any information herein may not be reproduced without prior written permission from TOSHIBA. Even with TOSHIBA's written permission, reproduction is permissible only if reproduction is without alteration/omission.
- Though TOSHIBA works continually to improve Product's quality and reliability, Product can malfunction or fail. Customers are responsible for complying with safety standards and for providing adequate designs and safeguards for their hardware, software and systems which minimize risk and avoid situations in which a malfunction or failure of Product could cause loss of human life, bodily injury or damage to property, including data loss or corruption. Before customers use the Product, create designs including the Product, or incorporate the Product into their own applications, customers must also refer to and comply with (a) the latest versions of all relevant TOSHIBA information, including without limitation, this document, the specifications, the data sheets and application notes for Product and the precautions and conditions set forth in the "TOSHIBA Semiconductor Reliability Handbook" and (b) the instructions for the application with which the Product will be used with or for. Customers are solely responsible for all aspects of their own product design or applications, including but not limited to (a) determining the appropriateness of the use of this Product in such design or applications; (b) evaluating and determining the applicability of any information contained in this document, or in charts, diagrams, programs, algorithms, sample application circuits, or any other referenced documents; and (c) validating all operating parameters for such designs and applications. **TOSHIBA ASSUMES NO LIABILITY FOR CUSTOMERS' PRODUCT DESIGN OR APPLICATIONS.**
- **PRODUCT IS NEITHER INTENDED NOR WARRANTED FOR USE IN EQUIPMENTS OR SYSTEMS THAT REQUIRE EXTRAORDINARILY HIGH LEVELS OF QUALITY AND/OR RELIABILITY, AND/OR A MALFUNCTION OR FAILURE OF WHICH MAY CAUSE LOSS OF HUMAN LIFE, BODILY INJURY, SERIOUS PROPERTY DAMAGE AND/OR SERIOUS PUBLIC IMPACT ("UNINTENDED USE").** Except for specific applications as expressly stated in this document, Unintended Use includes, without limitation, equipment used in nuclear facilities, equipment used in the aerospace industry, medical equipment, equipment used for automobiles, trains, ships and other transportation, traffic signaling equipment, equipment used to control combustions or explosions, safety devices, elevators and escalators, devices related to electric power, and equipment used in finance-related fields. **IF YOU USE PRODUCT FOR UNINTENDED USE, TOSHIBA ASSUMES NO LIABILITY FOR PRODUCT.** For details, please contact your TOSHIBA sales representative.
- Do not disassemble, analyze, reverse-engineer, alter, modify, translate or copy Product, whether in whole or in part.
- Product shall not be used for or incorporated into any products or systems whose manufacture, use, or sale is prohibited under any applicable laws or regulations.
- The information contained herein is presented only as guidance for Product use. No responsibility is assumed by TOSHIBA for any infringement of patents or any other intellectual property rights of third parties that may result from the use of Product. No license to any intellectual property right is granted by this document, whether express or implied, by estoppel or otherwise.
- **ABSENT A WRITTEN SIGNED AGREEMENT, EXCEPT AS PROVIDED IN THE RELEVANT TERMS AND CONDITIONS OF SALE FOR PRODUCT, AND TO THE MAXIMUM EXTENT ALLOWABLE BY LAW, TOSHIBA (1) ASSUMES NO LIABILITY WHATSOEVER, INCLUDING WITHOUT LIMITATION, INDIRECT, CONSEQUENTIAL, SPECIAL, OR INCIDENTAL DAMAGES OR LOSS, INCLUDING WITHOUT LIMITATION, LOSS OF PROFITS, LOSS OF OPPORTUNITIES, BUSINESS INTERRUPTION AND LOSS OF DATA, AND (2) DISCLAIMS ANY AND ALL EXPRESS OR IMPLIED WARRANTIES AND CONDITIONS RELATED TO SALE, USE OF PRODUCT, OR INFORMATION, INCLUDING WARRANTIES OR CONDITIONS OF MERCHANTABILITY, FITNESS FOR A PARTICULAR PURPOSE, ACCURACY OF INFORMATION, OR NONINFRINGEMENT.**
- Do not use or otherwise make available Product or related software or technology for any military purposes, including without limitation, for the design, development, use, stockpiling or manufacturing of nuclear, chemical, or biological weapons or missile technology products (mass destruction weapons). Product and related software and technology may be controlled under the applicable export laws and regulations including, without limitation, the Japanese Foreign Exchange and Foreign Trade Law and the U.S. Export Administration Regulations. Export and re-export of Product or related software or technology are strictly prohibited except in compliance with all applicable export laws and regulations.
- Please contact your TOSHIBA sales representative for details as to environmental matters such as the RoHS compatibility of Product. Please use Product in compliance with all applicable laws and regulations that regulate the inclusion or use of controlled substances, including without limitation, the EU RoHS Directive. **TOSHIBA ASSUMES NO LIABILITY FOR DAMAGES OR LOSSES OCCURRING AS A RESULT OF NONCOMPLIANCE WITH APPLICABLE LAWS AND REGULATIONS.**