

TOSHIBA CCD Linear Image Sensor CCD (Charge Coupled Device)

TCD1209DG

TOSHIBA CCD Linear Image Sensor CCD (Charge Coupled Device)

TCD1209DG

The TCD1209DG is a high sensitive and low dark current 2048 elements CCD linear image sensor.

The device contains a row of 2048 elements photodiodes which provide 8 lines/mm across a B4 size paper. The device is operated by 5.0 V pulse and 12 V power supply.

Features

- Number of Image Sensing Elements: 2048 elements
- Image Sensing Element Size: 14µm by 14µm on 14µm center
- Photo Sensing Region: High sensitive PN photodiode
- Clock: 2-phase (5 V)
- Power Supply Voltage: 12 V (typ.)
- Package: 22 pin CERDIP

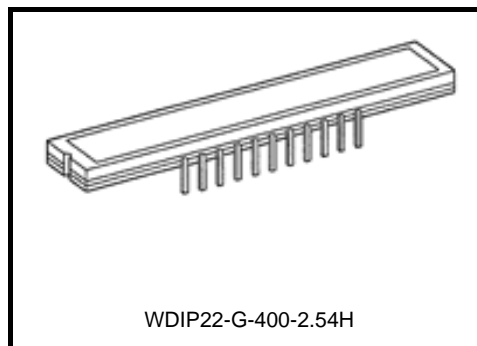

ABSOLUTE MAXIMUM RATINGS (Note 1)

Characteristic	Symbol	Rating	Unit
Clock pulse voltage	V_{ϕ}	-0.3 to +8.0	V
Shift pulse voltage	V_{SH}		
Reset pulse voltage	V_{RS}		
Clamp pulse voltage	V_{CP}		
Power supply voltage	V_{OD}	-0.3 to +15.0	V
Operating temperature	T_{opr}	-25 to +60	°C
Storage temperature	T_{stg}	-40 to +100	°C

Note 1: All voltages are with respect to SS terminals (ground).
 None of the ABSOLUTE MAXIMUM RATINGS must be exceeded, even instantaneously.
 If any one of the ABSOLUTE MAXIMUM RATINGS is exceeded, the electrical characteristics, reliability and life time of the device cannot be guaranteed. If the ABSOLUTE MAXIMUM RATINGS are exceeded, the device can be permanently damaged or degraded.
 Create a system design in such a manner that any of the ABSOLUTE MAXIMUM RATINGS will not be exceeded under any circumstances.

Pin Connections (top view)

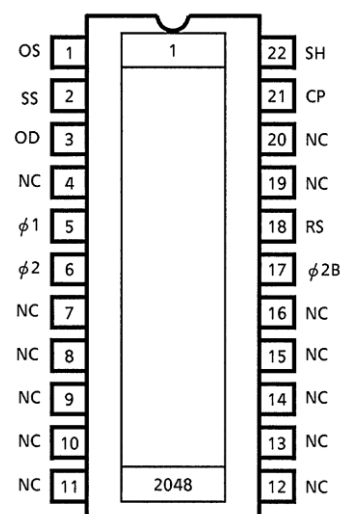

Circuit Diagram

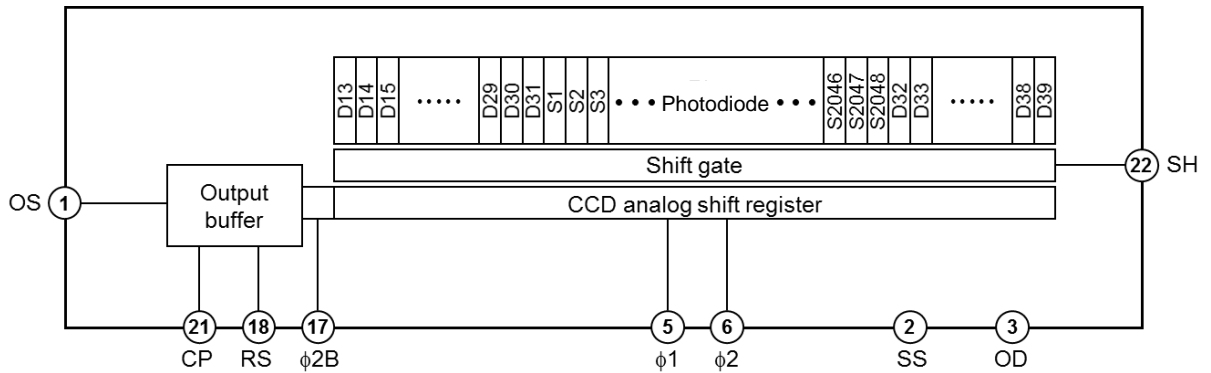

Pin Names

Pin No.	Symbol	Name	Pin No.	Symbol	Name
1	OS	Output signal	22	SH	Shift gate
2	SS	Ground	21	CP	Clamp gate
3	OD	Power supply	20	NC	Non connection
4	NC	Non connection	19	NC	Non connection
5	$\phi 1$	Transfer clock (phase 1)	18	RS	Reset gate
6	$\phi 2$	Transfer clock (phase 2)	17	$\phi 2B$	Last stage transfer clock (phase 2)
7	NC	Non connection	16	NC	Non connection
8	NC	Non connection	15	NC	Non connection
9	NC	Non connection	14	NC	Non connection
10	NC	Non connection	13	NC	Non connection
11	NC	Non connection	12	NC	Non connection

Optical/Electrical Characteristics

Ta = 25°C, VOD = 12 V, Vφ = VSH = VRS = VCP = 5 V (pulse), fφ = 1.0 MHz,
 tINT (integration time) = 10 ms, light source = daylight fluorescent lamp

Characteristic	Symbol	Min	Typ.	Max	Unit	Note
Sensitivity	R	25	31	37	V/lx·s	—
Photo response non uniformity	PRNU (1)	—	3	10	%	(Note 2)
	PRNU (3)	—	4	10	mV	(Note 8)
Saturation output voltage	VSAT	1.5	2.0	—	V	(Note 3)
Saturation exposure	SE	0.04	0.06	—	lx·s	(Note 4)
Dark signal voltage	VDRK	—	1.0	2.5	mV	(Note 5)
Dark signal non uniformity	DSNU	—	1.0	2.5	mV	(Note 5)
DC power dissipation	PD	—	160	400	mW	—
Total transfer efficiency	TTE	92	98	—	%	—
Output impedance	ZO	—	0.2	1.0	kΩ	—
Dynamic range	DR	—	2000	—	—	(Note 6)
DC output signal voltage	VOS	4.0	5.5	7.0	V	(Note 7)
Random noise	NDσ	—	0.6	—	mV	(Note 9)

Note 2: PRNU (1) is defined on a single chip by the expressions below when the photosensitive surface is applied with the light of uniform illumination and uniform color temperature, where measured approximately 500 mV of signal output.

$$PRNU(1) = \frac{\Delta X}{\bar{X}} \times 100 (\%)$$

\bar{X} : Average of total signal outputs
 ΔX : The maximum deviation from \bar{X}

Note 3: VSAT is defined as the minimum saturation output voltage of all effective pixels.

Note 4: Definition of SE:

$$SE = \frac{VSAT}{R}$$

Note 5: VDRK is defined as average dark signal voltage of all effective pixels.

DSNU is defined by the difference between average value (VDRK) and the maximum value of the dark voltage.

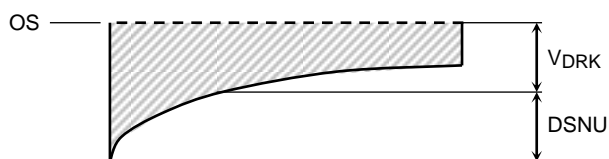

Note 6: Definition of DR:

$$DR = \frac{VSAT}{VDRK}$$

VDRK is proportional to tINT (integration time). So the shorter integration time makes wider dynamic range.

Note 7: DC output signal voltage is defined as follows.

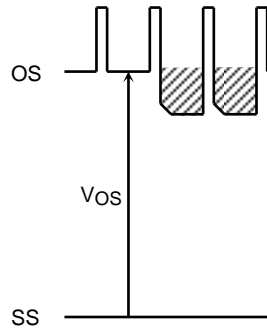

Note 8: PRNU (3) is defined as the maximum voltage with next pixel, where measured approximately 50 mV of signal output.

Note 9: Random noise is defined as the standard deviation (sigma) of the output level difference between two adjacent effective pixels under no illumination (i.e. dark condition) calculated by the following procedure.

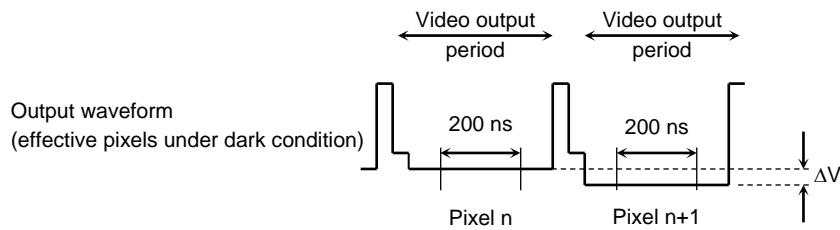

- 1) Two adjacent pixels (pixel n and n+1) in one reading are fixed as measurement points.
- 2) Each of the output levels at video output periods averaged over 200 ns period to get $V(n)$ and $V(n+1)$.
- 3) $V(n+1)$ is subtracted from $V(n)$ to get ΔV .
- 4) The standard deviation of ΔV is calculated after procedure 2) and 3) are repeated 30 times (30 readings).

$$\overline{\Delta V} = \frac{1}{30} \sum_{i=1}^{30} |\Delta V_i| \quad \sigma = \sqrt{\frac{1}{30} \sum_{i=1}^{30} (|\Delta V_i| - \overline{\Delta V})^2}$$

- 5) Procedure 2), 3) and 4) are repeated 10 times to get sigma value.
- 6) 10 sigma values are averaged.

$$\overline{\sigma} = \frac{1}{10} \sum_{j=1}^{10} \sigma_j$$

- 7) $\overline{\sigma}$ value calculated using the above procedure is observed $\sqrt{2}$ times larger than that measured relative to the ground level. So we specify the random noise as follows.

$$ND_{\sigma} = \frac{1}{\sqrt{2}} \overline{\sigma}$$

Recommended Operating Conditions (Ta = 25°C)

For best performance, the device should be used within the Recommended Operating Conditions.

Characteristics		Symbol	Min	Typ.	Max	Unit
Clock pulse voltage	"H" level	$V_{\phi 1}$	4.5	5.0	5.5	V
	"L" level	$V_{\phi 2}$	0	0	0.5	
Last stage clock pulse voltage	"H" level	$V_{\phi 2B}$	4.5	5.0	5.5	V
	"L" level		0	0	0.5	
Shift pulse voltage	"H" level	V_{SH}	4.5	5.0	5.5	V
	"L" level		0	0	0.5	
Reset pulse voltage	"H" level	V_{RS}	4.5	5.0	5.5	V
	"L" level		0	0	0.5	
Clamp pulse voltage	"H" level	V_{CP}	4.5	5.0	5.5	V
	"L" level		0	0	0.5	
Power supply voltage		V_{OD}	11.4	12.0	13.0	V

Clock Characteristics (Ta = 25°C)

For best performance, the device should be used within the Recommended Operating Conditions.

Characteristic	Symbol	Min	Typ.	Max	Unit
Clock pulse frequency	f_{ϕ}	—	1	20	MHz
Reset pulse frequency	f_{RS}	—	1	20	MHz
Clock capacitance (Note 10)	$C_{\phi 1}$	—	200	—	pF
	$C_{\phi 2}$	—	200	—	pF
Last stage clock capacitance	$C_{\phi 2B}$	—	10	20	pF
Shift gate capacitance	C_{SH}	—	30	—	pF
Reset gate capacitance	C_{RS}	—	10	20	pF
Clamp gate capacitance	C_{CP}	—	10	20	pF

Note 10: $V_{OD} = 12\text{ V}$

Timing Chart

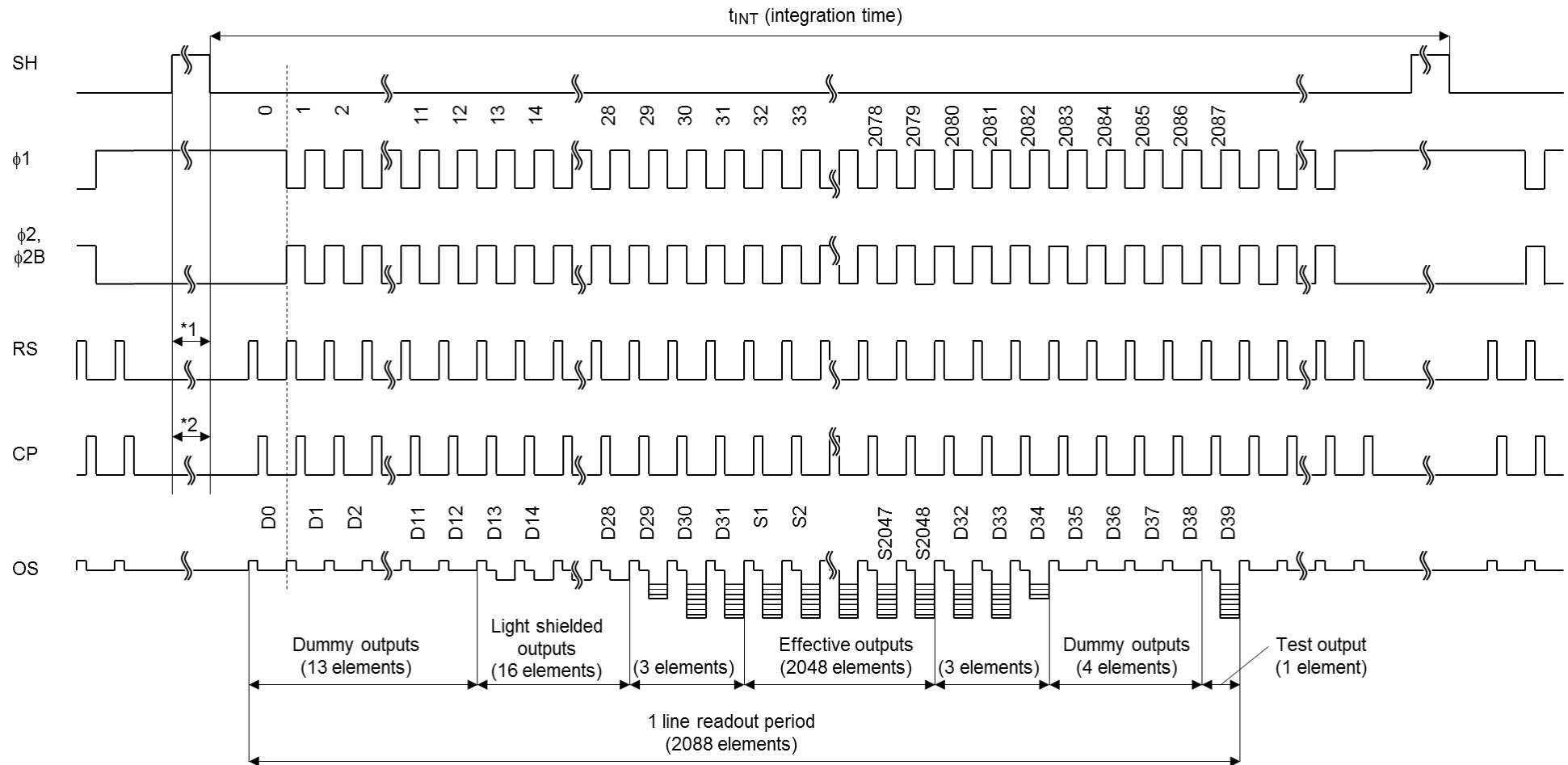

*1: Keep the RS pin "L" level.

*2: Keep the CP pin "L" level.

Timing Requirements

SH, $\phi 1$ Timing

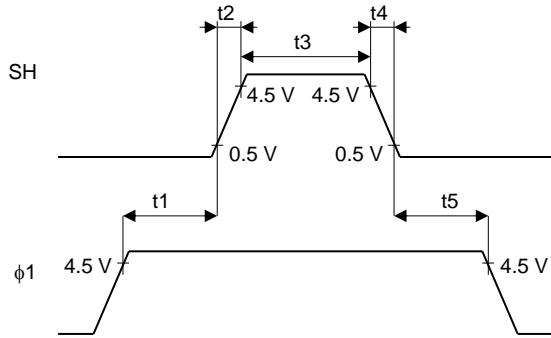

$\phi 2B$, RS, CP Timing

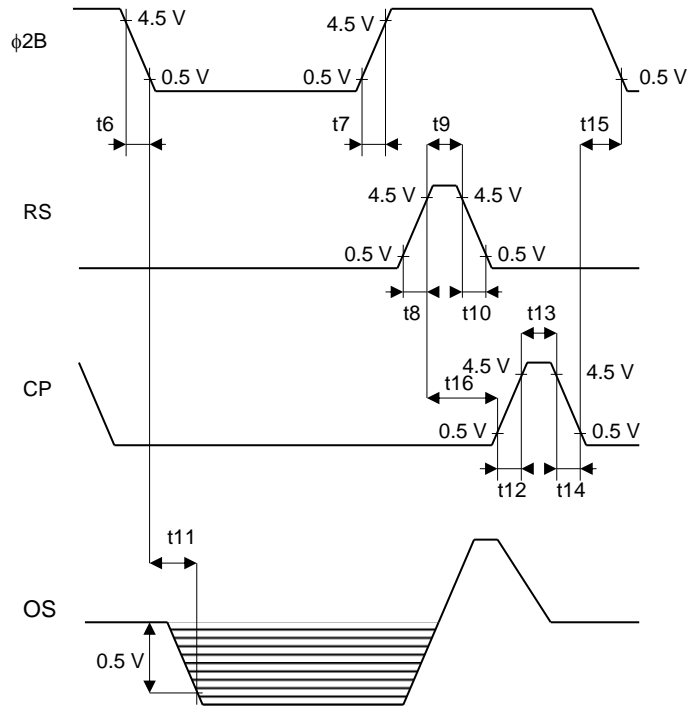

SH, RS, CP Timing

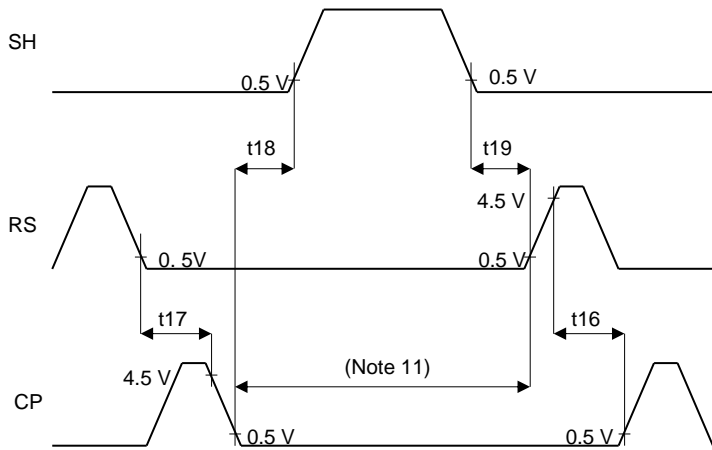

Note 11: Keep the RS and CP pins "L" level.

$\phi 1$, $\phi 2$ Cross point

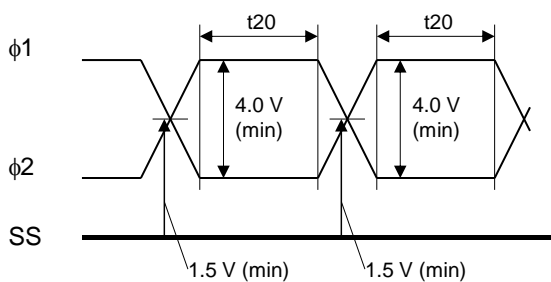

Characteristic	Symbol	Min	Typ. (Note 12)	Max	Unit
Pulse timing of SH and $\phi 1$	t1, t5	200 +t8+t12+t13+t14 +t16	500	—	ns
SH pulse rise time, fall time	t2, t4	0	50	—	ns
SH pulse width	t3	1000	1500	—	ns
$\phi 2B$ pulse rise time, fall time	t6, t7	0	100	—	ns
RS pulse rise time, fall time	t8, t10	0	20	—	ns
RS pulse width	t9	10	100	—	ns
Video data delay time	t11	—	15	—	ns
CP pulse rise time, fall time	t12, t14	0	20	—	ns
CP pulse width	t13	10	100	—	ns
Pulse timing of $\phi 2B$ and CP	t15	0	50	—	ns
Pulse timing of RS and CP	t16	0	100	—	ns
	t17	10	100	—	ns
Pulse timing of SH and CP	t18	200	—	—	ns
Pulse timing of SH and RS	t19	200	—	—	ns
Pulse timing of $\phi 1$ and $\phi 2$	t20	17	—	—	ns

Note 12: Measured with $f_{\phi} = 1$ MHz.

Cautions

1. Electrostatic Breakdown

Store in shorting clip or in conductive foam to avoid electrostatic breakdown.

CCD Image Sensor is protected against static electricity, but inferior puncture mode device due to static electricity is sometimes detected. In handling the device, it is necessary to execute the following static electricity preventive measures, in order to prevent the trouble rate increase of the manufacturing system due to static electricity.

- a. Prevent the generation of static electricity due to friction by making the work with bare hands or by putting on cotton gloves and non-charging working clothes.
- b. Discharge the static electricity by providing earth plate or earth wire on the floor, door or stand of the work room.
- c. Ground the tools such as soldering iron, radio cutting pliers or pincer.
- d. Ionized air is recommended for discharge when handling CCD image sensors.

It is not necessarily required to execute all precaution items for static electricity.

It is all right to mitigate the precautions by confirming that the trouble rate within the prescribed range.

2. Window Glass

The dust and stain on the glass window of the package degrade optical performance of CCD sensor.

Keep the glass window clean by saturating a cotton swab in alcohol and lightly wiping the surface, and allow the glass to dry, by blowing with filtered dry N₂. Care should be taken to avoid mechanical or thermal shock because the glass window is easily to damage.

3. Incident Light

CCD sensor is sensitive to infrared light. Note that infrared light component degrades resolution and PRNU of CCD sensor.

4. Mounting on a PCB

This package is sensitive to mechanical stress.

TOSHIBA recommends using IC inserters for mounting, instead of using lead forming equipment. Since this package is not strong against mechanical stress, you should not reform the lead frame. We recommend to use an IC-inserter when you assemble to PCB.

5. Soldering

Soldering by the solder flow method cannot be guaranteed because this method may have deleterious effects on prevention of window glass soiling and heat resistance.

Using a soldering iron, complete soldering within three seconds for lead temperatures of up to 350°C.

Package Dimensions

WDIP22-G-400-2.54H

Unit: mm

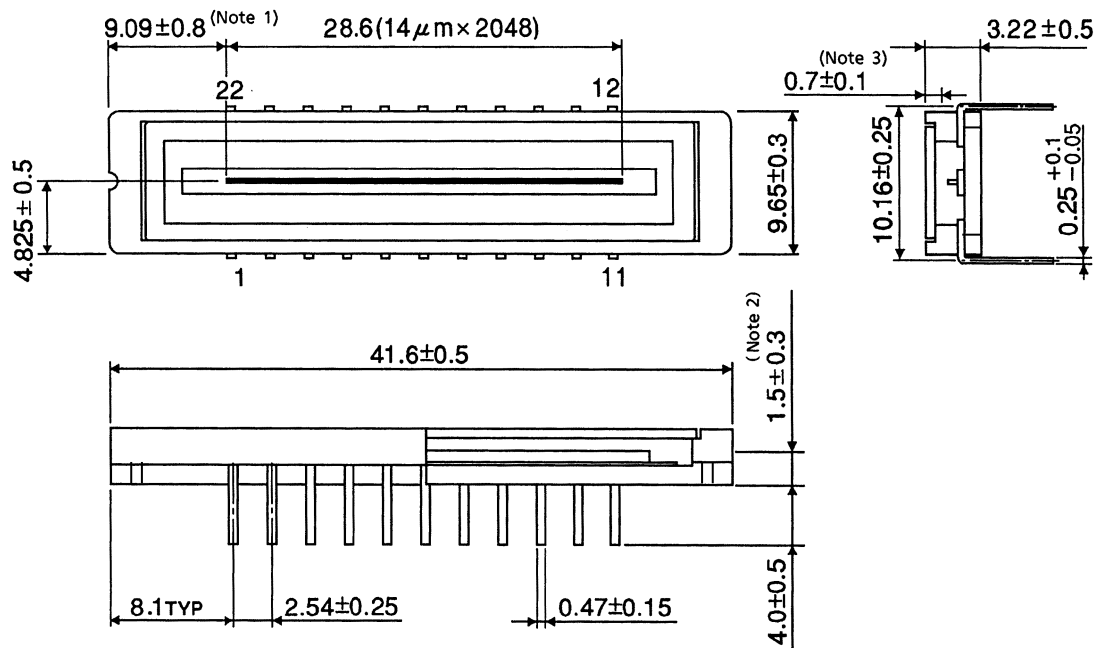

Note 1: Distance between the edge of the package and the first pixel (S1)

Note 2: Distance between the top of chip and bottom of the package

Note 3: Glass thickness ($n = 1.5$)

RESTRICTIONS ON PRODUCT USE

Toshiba Corporation and its subsidiaries and affiliates are collectively referred to as "TOSHIBA". Hardware, software and systems described in this document are collectively referred to as "Product".

- TOSHIBA reserves the right to make changes to the information in this document and related Product without notice.
- This document and any information herein may not be reproduced without prior written permission from TOSHIBA. Even with TOSHIBA's written permission, reproduction is permissible only if reproduction is without alteration/omission.
- Though TOSHIBA works continually to improve Product's quality and reliability, Product can malfunction or fail. Customers are responsible for complying with safety standards and for providing adequate designs and safeguards for their hardware, software and systems which minimize risk and avoid situations in which a malfunction or failure of Product could cause loss of human life, bodily injury or damage to property, including data loss or corruption. Before customers use the Product, create designs including the Product, or incorporate the Product into their own applications, customers must also refer to and comply with (a) the latest versions of all relevant TOSHIBA information, including without limitation, this document, the specifications, the data sheets and application notes for Product and the precautions and conditions set forth in the "TOSHIBA Semiconductor Reliability Handbook" and (b) the instructions for the application with which the Product will be used with or for. Customers are solely responsible for all aspects of their own product design or applications, including but not limited to (a) determining the appropriateness of the use of this Product in such design or applications; (b) evaluating and determining the applicability of any information contained in this document, or in charts, diagrams, programs, algorithms, sample application circuits, or any other referenced documents; and (c) validating all operating parameters for such designs and applications. **TOSHIBA ASSUMES NO LIABILITY FOR CUSTOMERS' PRODUCT DESIGN OR APPLICATIONS.**
- **PRODUCT IS NEITHER INTENDED NOR WARRANTED FOR USE IN EQUIPMENTS OR SYSTEMS THAT REQUIRE EXTRAORDINARILY HIGH LEVELS OF QUALITY AND/OR RELIABILITY, AND/OR A MALFUNCTION OR FAILURE OF WHICH MAY CAUSE LOSS OF HUMAN LIFE, BODILY INJURY, SERIOUS PROPERTY DAMAGE AND/OR SERIOUS PUBLIC IMPACT ("UNINTENDED USE").** Except for specific applications as expressly stated in this document, Unintended Use includes, without limitation, equipment used in nuclear facilities, equipment used in the aerospace industry, lifesaving and/or life supporting medical equipment, equipment used for automobiles, trains, ships and other transportation, traffic signaling equipment, equipment used to control combustions or explosions, safety devices, elevators and escalators, and devices related to power plant. **IF YOU USE PRODUCT FOR UNINTENDED USE, TOSHIBA ASSUMES NO LIABILITY FOR PRODUCT.** For details, please contact your TOSHIBA sales representative or contact us via our website.
- Do not disassemble, analyze, reverse-engineer, alter, modify, translate or copy Product, whether in whole or in part.
- Product shall not be used for or incorporated into any products or systems whose manufacture, use, or sale is prohibited under any applicable laws or regulations.
- The information contained herein is presented only as guidance for Product use. No responsibility is assumed by TOSHIBA for any infringement of patents or any other intellectual property rights of third parties that may result from the use of Product. No license to any intellectual property right is granted by this document, whether express or implied, by estoppel or otherwise.
- **ABSENT A WRITTEN SIGNED AGREEMENT, EXCEPT AS PROVIDED IN THE RELEVANT TERMS AND CONDITIONS OF SALE FOR PRODUCT, AND TO THE MAXIMUM EXTENT ALLOWABLE BY LAW, TOSHIBA (1) ASSUMES NO LIABILITY WHATSOEVER, INCLUDING WITHOUT LIMITATION, INDIRECT, CONSEQUENTIAL, SPECIAL, OR INCIDENTAL DAMAGES OR LOSS, INCLUDING WITHOUT LIMITATION, LOSS OF PROFITS, LOSS OF OPPORTUNITIES, BUSINESS INTERRUPTION AND LOSS OF DATA, AND (2) DISCLAIMS ANY AND ALL EXPRESS OR IMPLIED WARRANTIES AND CONDITIONS RELATED TO SALE, USE OF PRODUCT, OR INFORMATION, INCLUDING WARRANTIES OR CONDITIONS OF MERCHANTABILITY, FITNESS FOR A PARTICULAR PURPOSE, ACCURACY OF INFORMATION, OR NONINFRINGEMENT.**
- Do not use or otherwise make available Product or related software or technology for any military purposes, including without limitation, for the design, development, use, stockpiling or manufacturing of nuclear, chemical, or biological weapons or missile technology products (mass destruction weapons). Product and related software and technology may be controlled under the applicable export laws and regulations including, without limitation, the Japanese Foreign Exchange and Foreign Trade Law and the U.S. Export Administration Regulations. Export and re-export of Product or related software or technology are strictly prohibited except in compliance with all applicable export laws and regulations.
- Please contact your TOSHIBA sales representative for details as to environmental matters such as the RoHS compatibility of Product. Please use Product in compliance with all applicable laws and regulations that regulate the inclusion or use of controlled substances, including without limitation, the EU RoHS Directive. **TOSHIBA ASSUMES NO LIABILITY FOR DAMAGES OR LOSSES OCCURRING AS A RESULT OF NONCOMPLIANCE WITH APPLICABLE LAWS AND REGULATIONS.**

TOSHIBA ELECTRONIC DEVICES & STORAGE CORPORATION

<https://toshiba.semicon-storage.com/>