

# TC7USB40FT

## 1. Functional Description

- Dual SPDT USB Switch

## 2. General

The TC7USB40FT is high-speed CMOS dual 1-2 multiplexer/demultiplexer. The low ON-resistance and the low capacitance of the switch allow connections to USB2.0 (480Mbps) application.

This device consists of dual individual two-inputs multiplexer/demultiplexer with common select input (S) and output enable ( $\overline{OE}$ ). The D+/D- inputs is connected to the 1D+/1D- or 2D+/2D- outputs determined by the combination both the select input (S) and output enable ( $\overline{OE}$ ). When the output enable ( $\overline{OE}$ ) input is held high level, the switches are open with regardless the state of select inputs and a high-impedance state exists between the switches.

All inputs are equipped with protection circuits against static discharge.

## 3. Features

- (1) Supply voltage:  $V_{CC} = 2.3$  to  $4.3$  V
- (2) Switch terminal ON-capacitance:  $C_{IO} = 5$  pF Switch ON (typ.) @  $V_{CC} = 3.3$  V
- (3) ON-resistance:  $R_{ON} = 4.5 \Omega$  (typ.) @  $V_{CC} = 3$  V,  $V_{IS} = 0$  V
- (4)  $R_{ON}$  flatness:  $R_{ON(Flat)} = 1.3 \Omega$  (typ.) @  $V_{CC} = 3$  V
- (5) Difference of ON-resistance between switches:  $\Delta R_{ON} = 0.35 \Omega$  (typ.) @  $V_{CC} = 3$  V
- (6) -3dB Bandwidth:  $BW = 1.5$  GHz (typ.) @  $V_{CC} = 3.3$  V
- (7) Power-down protection provided on all inputs and outputs.
- (8) Package: TSSOP14

## 4. Packaging and Pin Assignment

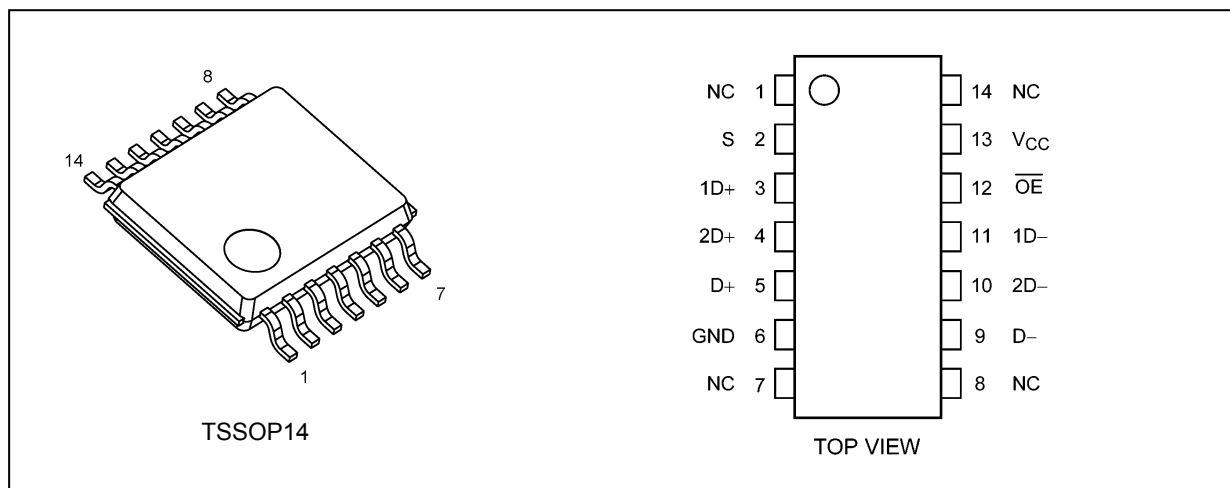

Start of commercial production  
2013-04

## 5. Marking

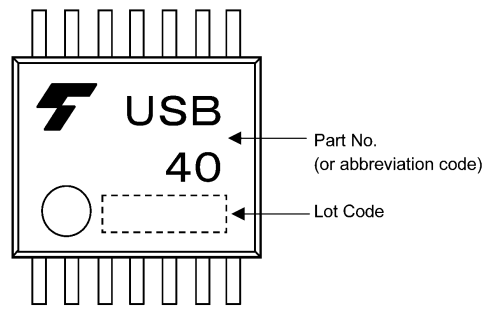

Fig. 5.1 Marking (Top view)

## 6. Block Diagram

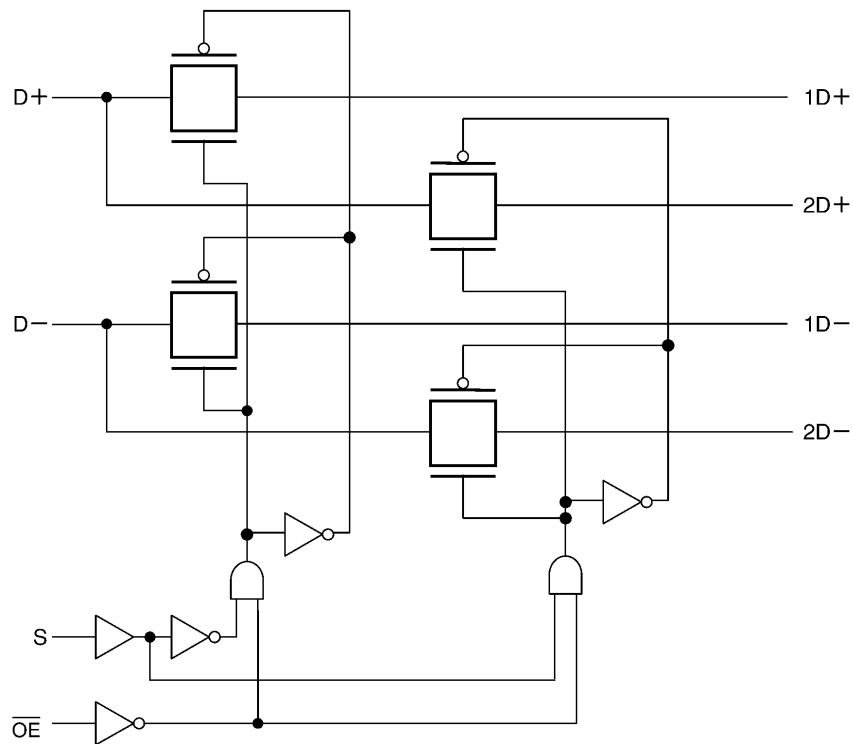

Fig. 6.1 Block Diagram

## 7. Principle of Operation

### 7.1. Truth Table

Input $\overline{OE}$	Input S	Function
L	L	D+ port = 1D+ port, D- Port = 1D- Port
L	H	D+ port = 2D+ port, D- Port = 2D- Port
H	X	Disconnect

X: Don't care

### 8. Absolute Maximum Ratings (Note)

Characteristics	Symbol	Test Condition	Rating	Unit
Supply voltage	$V_{CC}$	—	-0.5 to 4.6	V
Input voltage ( $\overline{OE}$ , S)	$V_{IN}$		-0.5 to 4.6	
Switch I/O voltage	$V_S$	$V_{CC} = 0\text{ V}$ or Switch OFF	-0.5 to 4.6	
		Switch ON	-0.5 to $V_{CC} + 0.5$	
Clamp diode current	$I_{IK}$	Control input	-50	mA
		Switch	$\pm 50$	
Switch I/O current	$I_S$	—	50	
Power dissipation	$P_D$		200	mW
$V_{CC}$ /ground current	$I_{CC}/I_{GND}$		$\pm 100$	mA
Storage temperature	$T_{stg}$		-65 to 150	$^{\circ}\text{C}$

Note: Exceeding any of the absolute maximum ratings, even briefly, lead to deterioration in IC performance or even destruction.

Using continuously under heavy loads (e.g. the application of high temperature/current/voltage and the significant change in temperature, etc.) may cause this product to decrease in the reliability significantly even if the operating conditions (i.e. operating temperature/current/voltage, etc.) are within the absolute maximum ratings and the operating ranges.

Please design the appropriate reliability upon reviewing the Toshiba Semiconductor Reliability Handbook (“Handling Precautions”/“Derating Concept and Methods”) and individual reliability data (i.e. reliability test report and estimated failure rate, etc).

### 9. Operating Ranges (Note)

Characteristics	Symbol	Test Condition	Rating	Unit
Supply voltage	$V_{CC}$	—	2.3 to 4.3	V
Input voltage ( $\overline{OE}$ , S)	$V_{IN}$		0 to 4.3	
Switch I/O voltage	$V_S$	$V_{CC} = 0\text{ V}$ or Switch OFF	0 to 4.3	
		Switch ON	0 to $V_{CC}$	
Operating temperature	$T_{opr}$	—	-40 to 85	$^{\circ}\text{C}$
Input rise time	dt/dv		0 to 10	ns/V
Input fall time			0 to 10	

Note: The operating ranges must be maintained to ensure the normal operation of the device.

Unused inputs and bus inputs must be tied to either  $V_{CC}$  or GND.

### 10. Electrical Characteristics

#### 10.1. DC Characteristics (Note) (Unless otherwise specified, $T_a = -40$ to $85^\circ\text{C}$ )

Characteristics	Symbol	Note	Test Condition	$V_{CC}$ (V)	Min	Typ.	Max	Unit
High-level input voltage ( $\overline{\text{OE}}$ , S)	$V_{IH}$		—	2.3 to 3.0	$0.50 \times V_{CC}$	—	—	V
				3.0 to 4.3	$0.46 \times V_{CC}$	—	—	
Low-level input voltage ( $\overline{\text{OE}}$ , S)	$V_{IL}$		—	2.3 to 4.3	—	—	$0.25 \times V_{CC}$	
Input leakage current ( $\overline{\text{OE}}$ , S)	$I_{IN}$		$V_{IN} = 0$ to 4.3 V	2.3 to 4.3	—	—	$\pm 1$	$\mu\text{A}$
Power-OFF leakage current	$I_{OFF}$		$V_{IN} = V_{IS} = 0$ to 4.3 V, See Fig. 11.10	0	—	—	$\pm 2$	
Switch OFF-state leakage current	$I_{SZ}$		$V_{IS} = 0$ to 3.6V, $\overline{\text{OE}} = V_{CC}$ , See Fig. 11.11	2.3 to 4.3	—	—	$\pm 2$	
ON-resistance	$R_{ON}$	(Note 1)	$V_{IS} = 0$ V, $I_{IS} = 30$ mA, See Fig. 11.9	3.0	—	4.5	6	$\Omega$
			$V_{IS} = 0.4$ V, $I_{IS} = 30$ mA, See Fig. 11.9	3.0	—	4.8	6.7	
			$V_{IS} = 3.0$ V, $I_{IS} = 30$ mA, See Fig. 11.9	3.0	—	10	14	
Difference of ON-resistance between switches	$\Delta R_{ON}$	(Note 1)	$V_{IS} = 0.4$ V, 1.0 V, $I_{IS} = 30$ mA	3.0	—	0.35	—	
ON-resistance flatness	$R_{ON(\text{flat})}$	(Note 1)	$V_{IS} = 0$ V to 1.0 V, $I_{IS} = 30$ mA	3.0	—	1.3	—	
Quiescent supply current	$I_{CC}$		$V_{IN} = V_{CC}$ or GND, $I_{OUT} = 0$ A	4.3	—	—	1	$\mu\text{A}$
	$\Delta I_{CC}$		$V_{IN} = 2.6$ V (one input)	4.3	—	—	40	

Note: All typical values are at  $T_a = 25^\circ\text{C}$ .

Note 1: Measured by the voltage drop between D+/D- and 1D+/1D-, 2D+/2D- pins at the indicated current through the switch. On-resistance is determined by the lower of the voltages on the two pins.

#### 10.2. AC Characteristics (Note) (Unless otherwise specified, $T_a = -40$ to $85^\circ\text{C}$ )

Characteristics	Symbol	Note	Test Condition	$V_{CC}$ (V)	Min	Typ.	Max	Unit
Propagation delay time	$t_{PLH}/t_{PHL}$	(Note 1)	$C_L = 5$ pF, See Fig. 11.1	$3.3 \pm 0.3$	—	0.25	—	ns
Turn-ON time (S, $\overline{\text{OE}}$ to output)	$t_{on}$		$R_L = 50 \Omega$ , $C_L = 5$ pF, See Fig. 11.2		—	10	20	
Turn-OFF time (S, $\overline{\text{OE}}$ to output)	$t_{off}$				—	14	24	
Break before make	TBBM		$R_L = 50 \Omega$ , $C_L = 5$ pF, See Fig. 11.3		2	—	7	
Skew of opposite transitions of the same output ( $t_{PHL} - t_{PLH}$ )	$t_{SK(P)}$	(Note 1)	$C_L = 5$ pF, See Fig. 11.4		—	0.1	—	
Output skew (center port to any other port)	$t_{SK(O)}$	(Note 1)	$C_L = 5$ pF, See Fig. 11.5		—	0.1	—	

Note: All typical values are at  $T_a = 25^\circ\text{C}$ .

Note 1: Parameter guaranteed by design.

### 10.3. Analog Switch (Note) (Unless otherwise specified, $T_a = 25^\circ\text{C}$ )

Characteristics	Symbol	Test Condition	$V_{CC}$ (V)	Min	Typ.	Max	Unit
OFF isolation (non-adjacent)	OIRR	$R_T = 50 \Omega$ , $f = 240 \text{ MHz}$ , See Fig. 11.6	$3.3 \pm 0.3$	—	-24	—	dB
Crosstalk (non-adjacent)	Xtalk	$R_T = 50 \Omega$ , $f = 240 \text{ MHz}$ , See Fig. 11.7		—	-30	—	
-3dB Bandwidth	BW	$R_T = 50 \Omega$ , $C_L = 0 \text{ pF}$ , See Fig. 11.8		—	1500	—	MHz

Note: Parameter guaranteed by design.

### 10.4. Capacitive Characteristics (Note) (Unless otherwise specified, $T_a = 25^\circ\text{C}$ )

Characteristics	Symbol	Test Condition	$V_{CC}$ (V)	Typ.	Unit
Input capacitance ( $\overline{OE}$ , S)	$C_{IN}$	$V_{IN} = 0 \text{ V}$	3.3	3	pF
Switch terminal OFF-capacitance (D+, D-)	$C_{I/O}$	$\overline{OE} = V_{CC}$ , $V_{IS} = 0 \text{ V}$		3	
Switch terminal OFF-capacitance (1D+, 1D-, 2D+, 2D-)				2	
Switch terminal ON-capacitance				$\overline{OE} = \text{GND}$ , $V_{IS} = 0 \text{ V}$	

Note: Parameter guaranteed by design.

### 11. AC Test Circuits and Waveforms

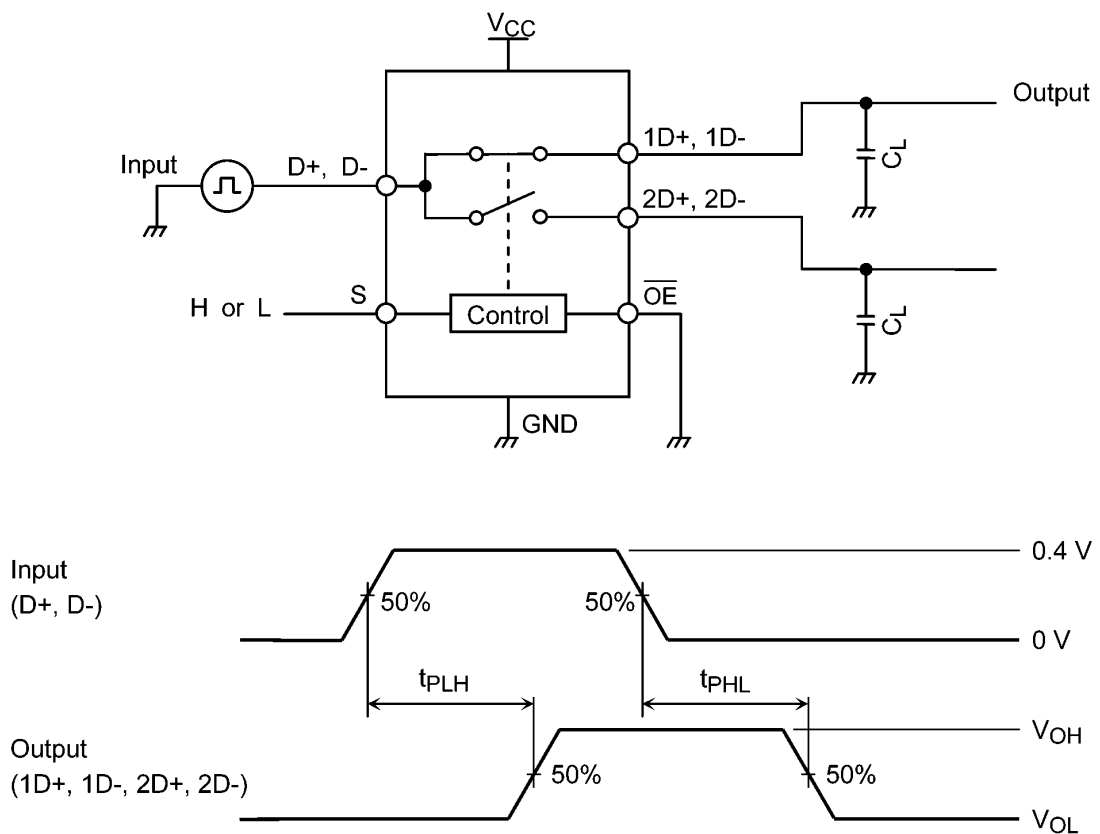

Fig. 11.1 Propagation Delay Time ( $t_{PLH}$ ,  $t_{PHL}$ )

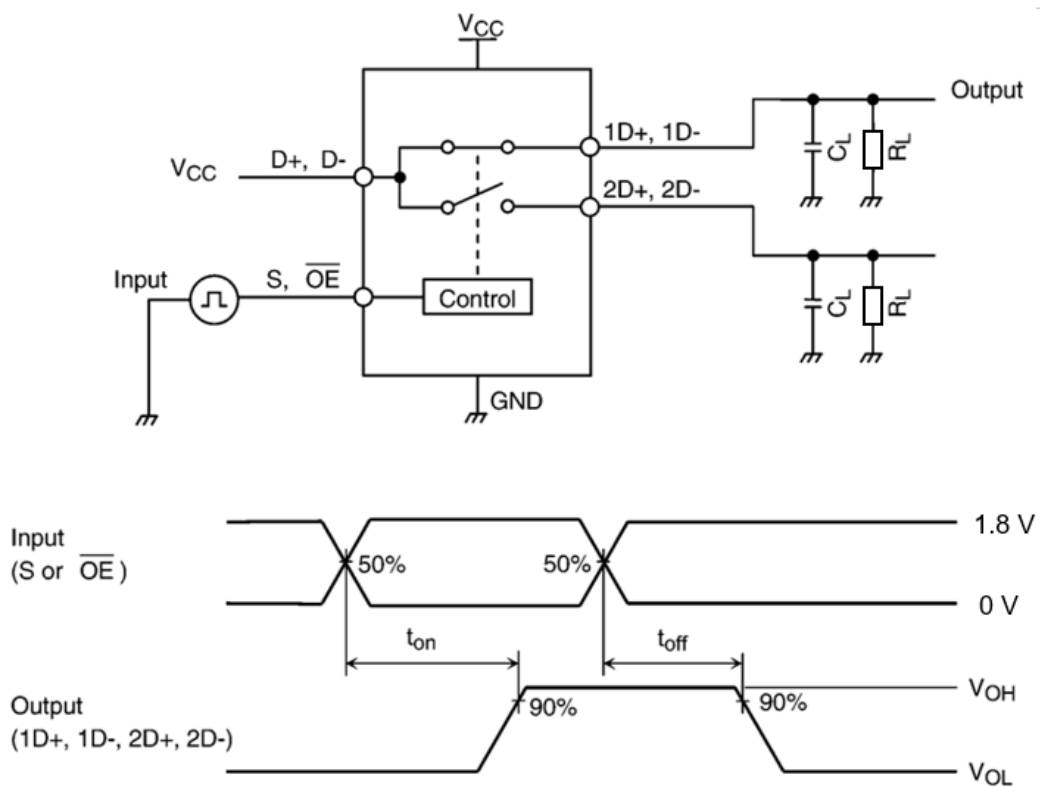

Fig. 11.2 Turn-ON and Turn-OFF Times ( $t_{on}$ ,  $t_{off}$ )

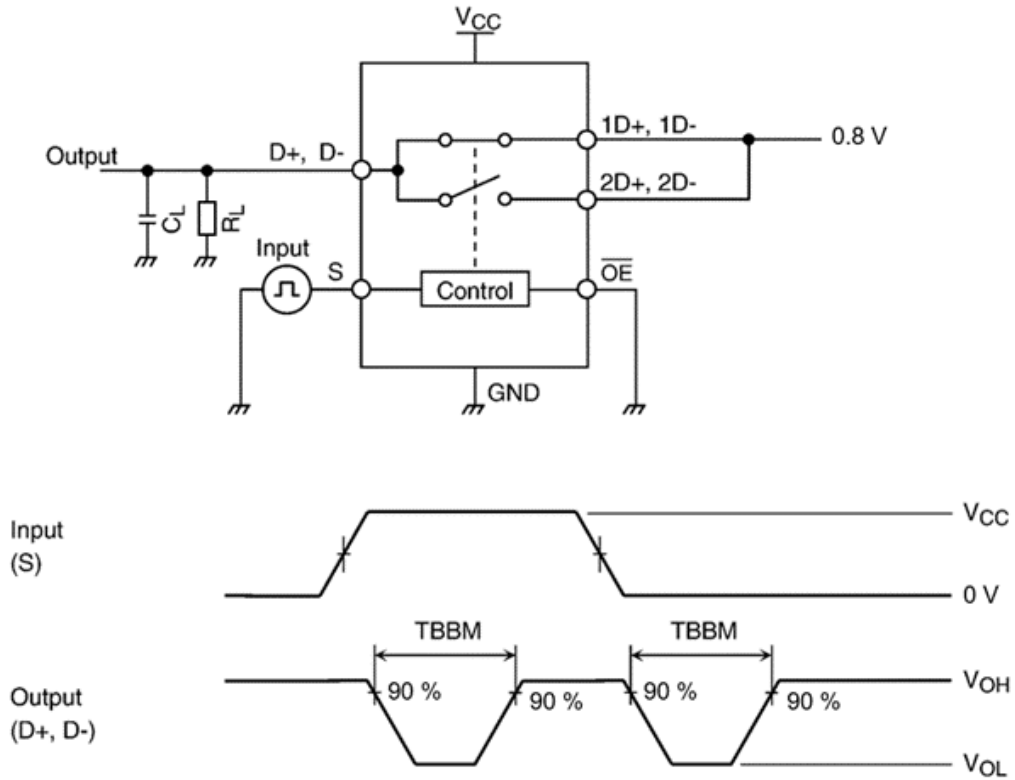

Fig. 11.3 Break Before Make (TBBM)

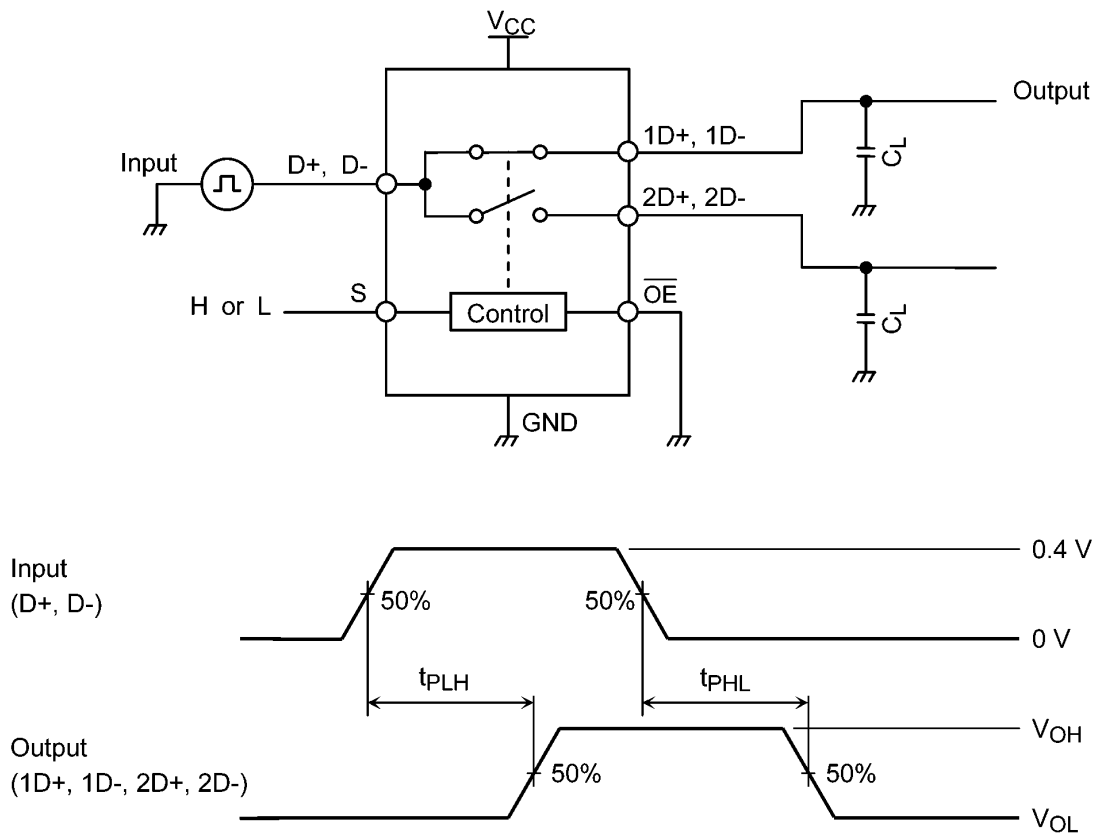

Fig. 11.4 Skew of opposite transitions of the same output ( $t_{sk(P)} = |t_{PHL} - t_{PLH}|$ )

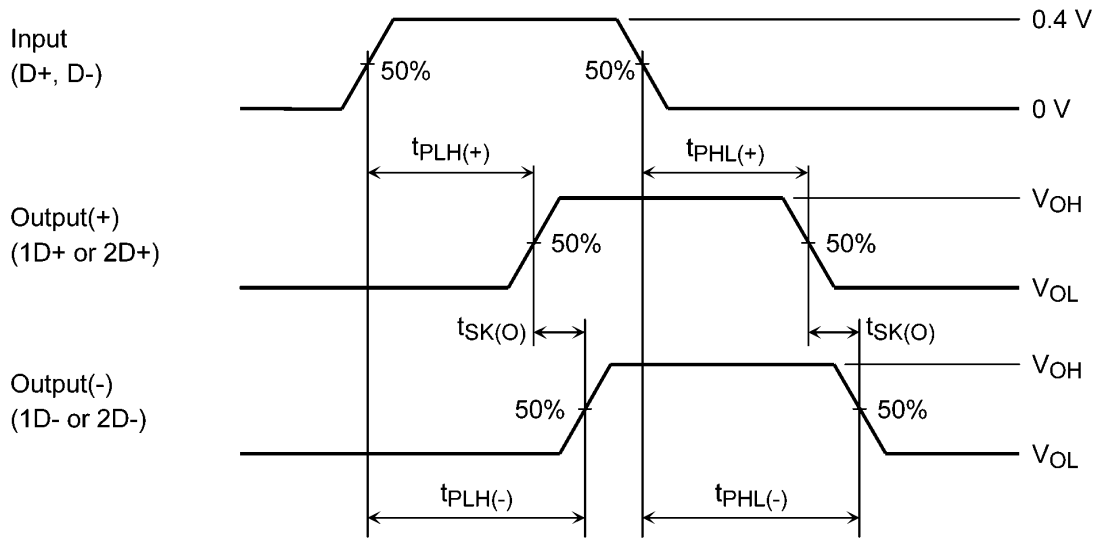

Fig. 11.5 Output Skew (center port to any other port)

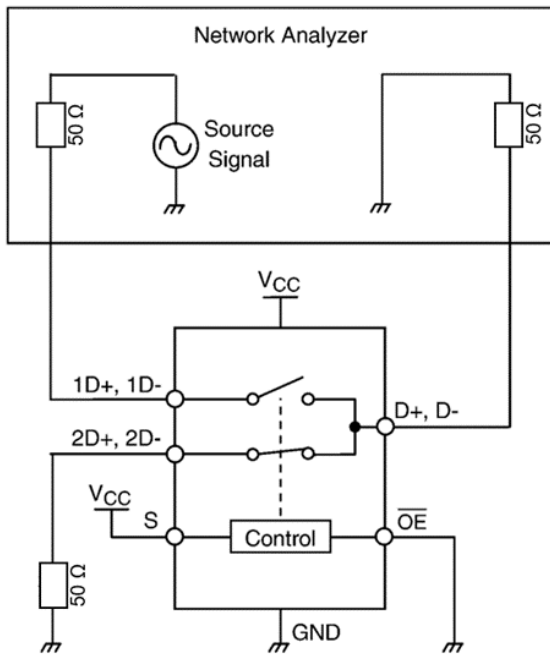

Fig. 11.6 OFF Isolation

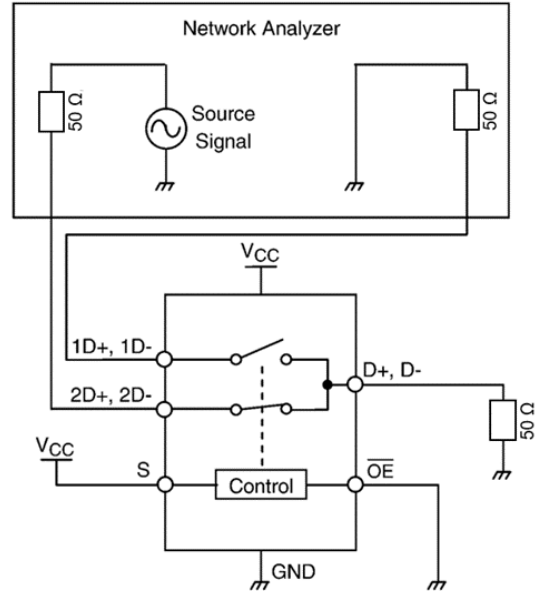

Fig. 11.7 Crosstalk

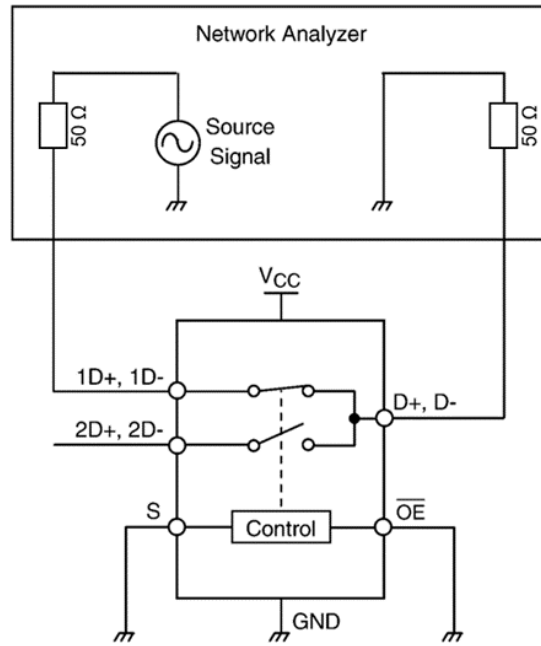

Fig. 11.8 -3dB Bandwidth

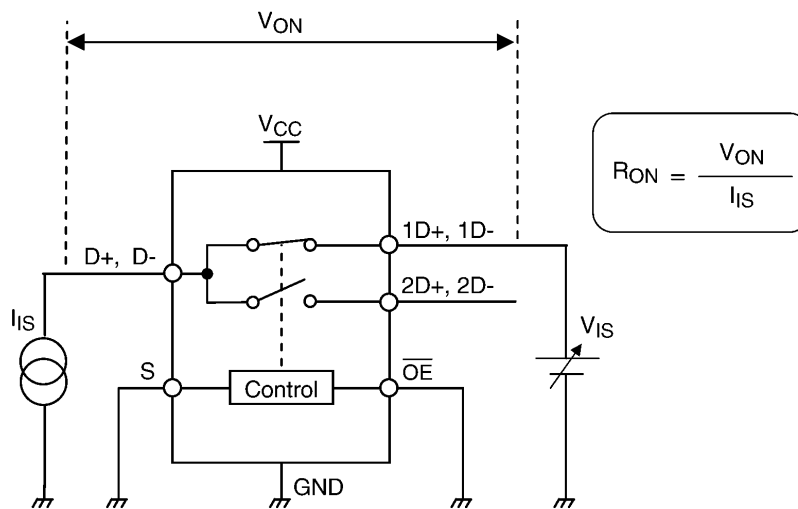

Fig. 11.9 ON-Resistance

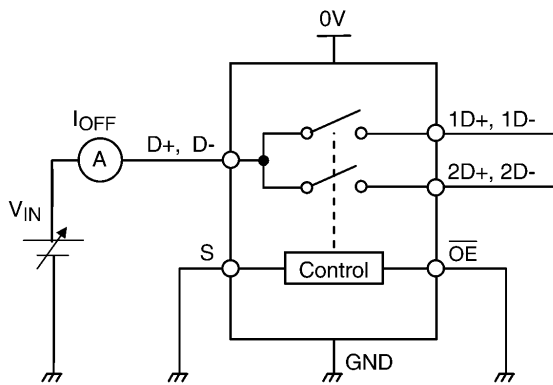

Fig. 11.10 Power-OFF Leakage Current

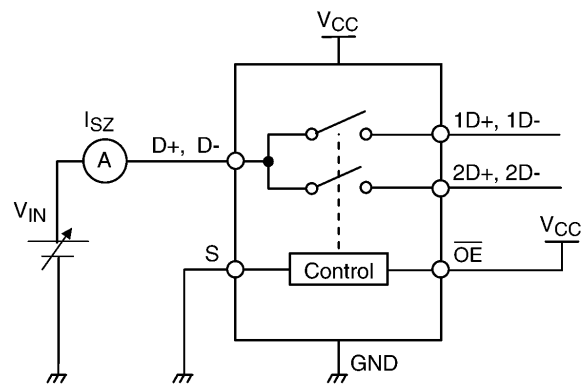
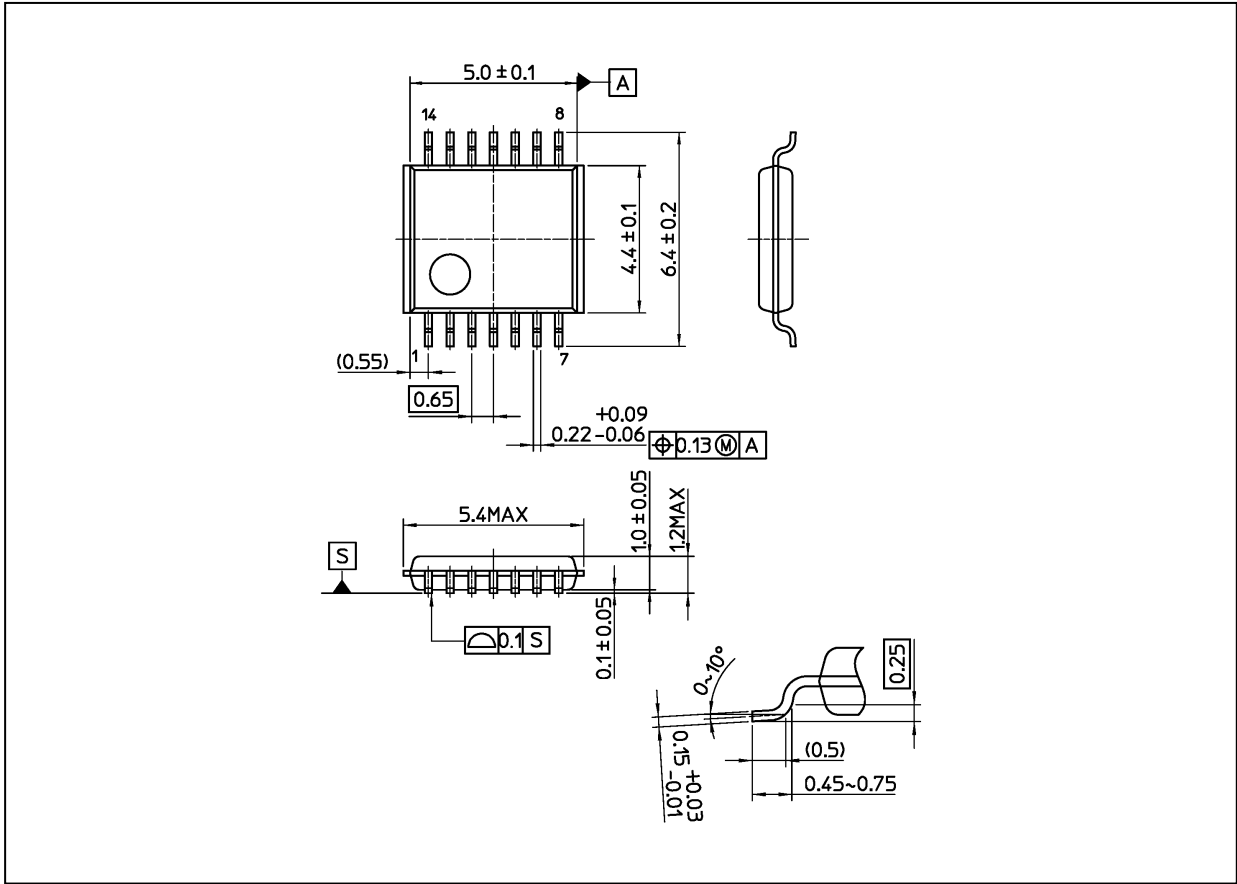

Fig. 11.11 Switch OFF-state leakage current

### Package Dimensions

Unit: mm



Weight: 0.06 g (typ.)

Package Name(s)
Nickname: TSSOP14

## RESTRICTIONS ON PRODUCT USE

Toshiba Corporation and its subsidiaries and affiliates are collectively referred to as "TOSHIBA".

Hardware, software and systems described in this document are collectively referred to as "Product".

- TOSHIBA reserves the right to make changes to the information in this document and related Product without notice.
- This document and any information herein may not be reproduced without prior written permission from TOSHIBA. Even with TOSHIBA's written permission, reproduction is permissible only if reproduction is without alteration/omission.
- Though TOSHIBA works continually to improve Product's quality and reliability, Product can malfunction or fail. Customers are responsible for complying with safety standards and for providing adequate designs and safeguards for their hardware, software and systems which minimize risk and avoid situations in which a malfunction or failure of Product could cause loss of human life, bodily injury or damage to property, including data loss or corruption. Before customers use the Product, create designs including the Product, or incorporate the Product into their own applications, customers must also refer to and comply with (a) the latest versions of all relevant TOSHIBA information, including without limitation, this document, the specifications, the data sheets and application notes for Product and the precautions and conditions set forth in the "TOSHIBA Semiconductor Reliability Handbook" and (b) the instructions for the application with which the Product will be used with or for. Customers are solely responsible for all aspects of their own product design or applications, including but not limited to (a) determining the appropriateness of the use of this Product in such design or applications; (b) evaluating and determining the applicability of any information contained in this document, or in charts, diagrams, programs, algorithms, sample application circuits, or any other referenced documents; and (c) validating all operating parameters for such designs and applications. **TOSHIBA ASSUMES NO LIABILITY FOR CUSTOMERS' PRODUCT DESIGN OR APPLICATIONS.**
- **PRODUCT IS NEITHER INTENDED NOR WARRANTED FOR USE IN EQUIPMENTS OR SYSTEMS THAT REQUIRE EXTRAORDINARILY HIGH LEVELS OF QUALITY AND/OR RELIABILITY, AND/OR A MALFUNCTION OR FAILURE OF WHICH MAY CAUSE LOSS OF HUMAN LIFE, BODILY INJURY, SERIOUS PROPERTY DAMAGE AND/OR SERIOUS PUBLIC IMPACT ("UNINTENDED USE").** Except for specific applications as expressly stated in this document, Unintended Use includes, without limitation, equipment used in nuclear facilities, equipment used in the aerospace industry, Class 3 medical devices, equipment used for automobiles, and military vehicles and munitions. **IF YOU USE PRODUCT FOR UNINTENDED USE, TOSHIBA ASSUMES NO LIABILITY FOR PRODUCT.** For details, please contact your TOSHIBA sales representative or contact us via our website.
- Do not disassemble, analyze, reverse-engineer, alter, modify, translate or copy Product, whether in whole or in part.
- Product shall not be used for or incorporated into any products or systems whose manufacture, use, or sale is prohibited under any applicable laws or regulations.
- The information contained herein is presented only as guidance for Product use. No responsibility is assumed by TOSHIBA for any infringement of patents or any other intellectual property rights of third parties that may result from the use of Product. No license to any intellectual property right is granted by this document, whether express or implied, by estoppel or otherwise.
- **ABSENT A WRITTEN SIGNED AGREEMENT, EXCEPT AS PROVIDED IN THE RELEVANT TERMS AND CONDITIONS OF SALE FOR PRODUCT, AND TO THE MAXIMUM EXTENT ALLOWABLE BY LAW, TOSHIBA (1) ASSUMES NO LIABILITY WHATSOEVER, INCLUDING WITHOUT LIMITATION, INDIRECT, CONSEQUENTIAL, SPECIAL, OR INCIDENTAL DAMAGES OR LOSS, INCLUDING WITHOUT LIMITATION, LOSS OF PROFITS, LOSS OF OPPORTUNITIES, BUSINESS INTERRUPTION AND LOSS OF DATA, AND (2) DISCLAIMS ANY AND ALL EXPRESS OR IMPLIED WARRANTIES AND CONDITIONS RELATED TO SALE, USE OF PRODUCT, OR INFORMATION, INCLUDING WARRANTIES OR CONDITIONS OF MERCHANTABILITY, FITNESS FOR A PARTICULAR PURPOSE, ACCURACY OF INFORMATION, OR NONINFRINGEMENT.**
- Do not use or otherwise make available Product or related software or technology for any military purposes, including without limitation, for the design, development, use, stockpiling or manufacturing of nuclear, chemical, or biological weapons or missile technology products (mass destruction weapons). Product and related software and technology may be controlled under the applicable export laws and regulations including, without limitation, the Japanese Foreign Exchange and Foreign Trade Law and the U.S. Export Administration Regulations. Export and re-export of Product or related software or technology are strictly prohibited except in compliance with all applicable export laws and regulations.
- Please contact your TOSHIBA sales representative for details as to environmental matters such as the RoHS compatibility of Product. Please use Product in compliance with all applicable laws and regulations that regulate the inclusion or use of controlled substances, including without limitation, the EU RoHS Directive. **TOSHIBA ASSUMES NO LIABILITY FOR DAMAGES OR LOSSES OCCURRING AS A RESULT OF NONCOMPLIANCE WITH APPLICABLE LAWS AND REGULATIONS.**