

Basics of Diodes (Power Losses and Thermal Design)

Outline:

Diodes are used in a wide range of equipment for various applications such as rectification, reverse-current blocking, and circuit protection. In addition to silicon (Si) pn diodes, various other types of diodes are available, including Schottky barrier diodes (SBDs), transient voltage suppressor (TVS) diodes (also known as ESD protection diodes), and Zener diodes. Toshiba's product portfolio also includes state-of-the-art silicon carbide (SiC) SBDs fabricated using a compound semiconductor. This application note discusses the power losses of and thermal design for diodes.

Table of Contents

Outline:.....	1
Table of Contents	2
1. Power losses of a diode	4
2. Thermal design	6
2.1. Maximum allowable power dissipation and equivalent thermal circuit.....	6
2.2. Thermal resistance.....	7
2.3. Pulse response of junction temperature.....	9
RESTRICTIONS ON PRODUCT USE	14

List of Figures

Figure 1.1 Example of a diode's switching waveform	4
Figure 2.1 Equivalent thermal circuit	6
Figure 2.2 Example of thermal resistance-vs-heatsink area curves.....	8
Figure 2.3 Thermal impedance model.....	9
Figure 2.4 Change in junction temperature	9
Figure 2.5 Example of transient thermal impedance curves	10
Figure 2.6 Change in junction temperature caused by repetitive application of rectangular pulsed power dissipation at a cyclic period of T	11
Figure 2.7 Approximation of a power dissipation waveform	12
Figure 2.8 Approximating sine and triangular waves to rectangular waves	12

1. Power losses of a diode

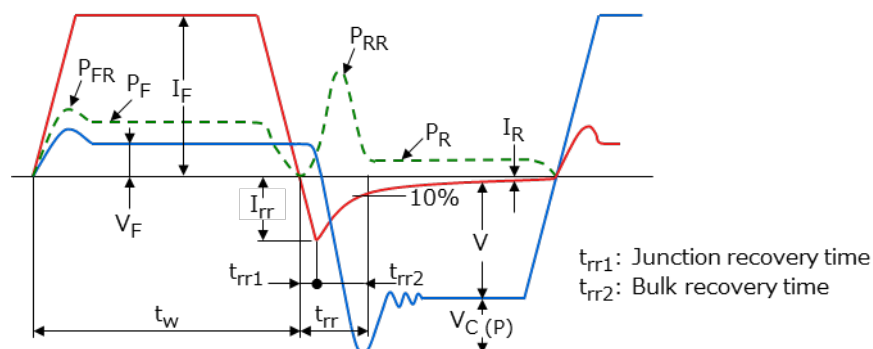

Figure 1.1 Example of a diode's switching waveform

(1) Forward power loss (P_F)

Normally, when a silicon (Si) diode is forward-biased, the forward voltage (V_F) decreases as temperature increases. The device temperature settles at a certain point. In the case of a silicon carbide (SiC) Schottky barrier diode (SBD), V_F has a positive temperature coefficient in the high- I_F region. It is therefore necessary to ensure that the rated forward power dissipation and junction temperature are not exceeded.

(2) Reverse power loss (P_R)

The power loss due to reverse leakage current (I_R) is negligibly smaller than forward power loss at low temperature. However, since I_R increases exponentially with temperature, the power loss due to I_R cannot be ignored at high temperature. Furthermore, if self-heating caused by I_R exceeds the heat dissipation capability of a diode, thermal runaway might occur. Regarding reverse power loss, it is necessary to allow sufficient margin for the maximum rated junction temperature and thermal runaway.

Si SBDs and fast rectifier diodes have higher I_R than typical rectifier diodes. In particular, a rise in temperature and an increase in current during operation make Si SBDs susceptible to thermal runaway, possibly leading to device destruction. For Si SBDs and fast rectifier diodes, it is necessary to calculate the power dissipation at high temperature, taking forward and reverse power losses into consideration, and use it as a basis for thermal and safety design. In addition, it is essential to perform verification using actual hardware to ensure that it works properly under the worst-case condition.

(3) Forward switching loss (P_{FR})

The forward switching loss (P_{FR}) is the loss that occurs when a rapidly rising rectangular wave pulse is applied to a diode in the forward direction.

The application of a pulse causes a diode's forward voltage to rise instantaneously above the

steady-state forward voltage (V_F), increasing power dissipation (see Figure 1.1).

When a rapidly rising pulse is applied to a diode, it does not enter a conducting state immediately because carriers are not accumulated. During a certain period, a diode exhibits high resistance even in the forward direction. This phenomenon is called forward recovery. The forward recovery time (t_{fr}) is not dependent on the operating frequency, but on the rise time.

(4) Reverse switching loss (P_{RR})

The reverse switching loss (P_{RR}) is the loss that occurs when a rapidly rising reverse voltage pulse is applied to a diode. A power loss occurs while reverse current flows during the reverse recovery time (t_{rr}) since it cannot be blocked immediately (see Figure 1.1). The reverse switching loss (P_{RR}) is approximated as follows:

$$P_{RR} \approx \frac{1}{2} i_{rr} \cdot t_{rr} \cdot V_R \cdot f = Q_R \cdot V_R \cdot f \quad \dots\dots\dots (1-1)$$

- i_{rr} : Peak reverse current (A)
- t_{rr} : Reverse recovery time (s)
- V_R : Reverse voltage (in a steady state) (V)
- Q_R : Accumulated charge (C)
- f : Frequency (Hz)

A power loss occurs during the t_{rr2} period of t_{rr} . Since the power loss during t_{rr1} is small, Equation 1-1 can be approximated as:

$$P_{RR} \approx \frac{1}{6} i_{rr} \cdot t_{rr2} \cdot V_R \cdot f \quad \dots\dots\dots (1-2)$$

- i_{rr} : Peak reverse current (A)
- t_{rr2} : Bulk recovery time (s)
- V_R : Reverse voltage (in a steady state) (V)
- f : Frequency (Hz)

2. Thermal design

2.1. Maximum allowable power dissipation and equivalent thermal circuit

The power dissipation of a diode is a function of ambient temperature (T_a), case temperature (T_c), junction-to-ambient thermal resistance ($R_{th(j-a)}$), junction-to-case thermal resistance ($R_{th(j-c)}$), and maximum junction temperature ($T_{j(max)}$) as expressed by Equations 2-1 and 2-2:

$$P_{C(max)(T_a)} = \frac{T_{j(max)} - T_a}{R_{th(j-a)}} \dots\dots\dots (2-1)$$

$$P_{C(max)(T_c)} = \frac{T_{j(max)} - T_c}{R_{th(j-c)}} \dots\dots\dots (2-2)$$

A heat flow can be modeled by analogy to an electrical circuit. Using this model, the heat flow from the junction of a diode to the ambient air is derived from thermal resistances and thermal capacitances. Figure 2.1 shows an equivalent thermal circuit in a thermally steady state.

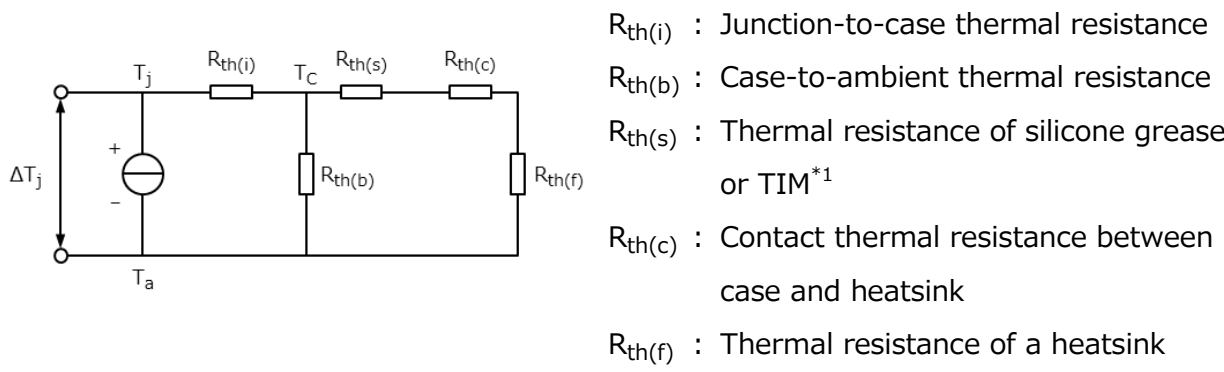

Figure 2.1 Equivalent thermal circuit *1 Thermal interface material (TIM)

From the equivalent circuit of Figure 2.1, the junction-to-ambient thermal resistance ($R_{th(j-a)}$) can be calculated as follows:

$$R_{th(j-a)} = R_{th(i)} + \frac{R_{th(b)} \cdot (R_{th(s)} + R_{th(c)} + R_{th(f)})}{R_{th(b)} + R_{th(s)} + R_{th(c)} + R_{th(f)}} \dots\dots\dots (2-3)$$

The $R_{th(j-a)}$ of a diode without a heatsink can be calculated as follows:

$$R_{th(j-a)} = R_{th(i)} + R_{th(b)} \dots\dots\dots (2-4)$$

The datasheets for diodes without a heatsink show their maximum allowable power dissipation at an ambient temperature (T_a) of 25°C. Unless specifically otherwise noted, this is calculated as follows from $R_{th(j-a)}$ given by Equation 2-4 and $T_{j(max)}$:

$$P_{C(max)(T_a=25^\circ C)} = \frac{T_{j(max)} - 25}{R_{th(j-a)}} \dots\dots\dots (2-5)$$

The case-to-ambient thermal resistance ($R_{th(b)}$) varies with the materials and shape of the case. Generally, $R_{th(b)}$ is significantly larger than $R_{th(i)}$, $R_{th(c)}$, $R_{th(s)}$, and $R_{th(f)}$. Therefore, Equation 2-3 can be simplified to:

$$R_{th(j-a)} = R_{th(i)} + R_{th(c)} + R_{th(s)} + R_{th(f)} \dots\dots\dots (2-6)$$

Equation 2-6 can be used to create a thermal design that satisfies the maximum rating requirement for DC dissipation. When diodes are used in a switching circuit, great care is required to ensure that the peak T_j value does not exceed $T_{j(max)}$.

2.2. Thermal resistance

The thermal resistance values shown in the equivalent thermal circuit of Figure 2.1 can be explained as follows:

(1) Junction-to-case thermal resistance (internal thermal resistance): $R_{th(i)}$

The internal thermal resistance ($R_{th(i)}$) from the junction of a diode to the case depends on the structure and material of the diode and differs from diode to diode. To measure internal thermal resistance, the case of the diode must be cooled to maintain a constant temperature. When the case temperature (T_c) is held at 25°C, the maximum allowable power dissipation ($P_{C(max)}$) of a diode can be calculated as follows:

$$P_{C(max)} = \frac{T_{j(max)} - T_c}{R_{th(i)}} = \frac{T_{j(max)} - 25}{R_{th(i)}} \dots\dots\dots (2-7)$$

In the datasheets for diodes that can be attached to a heatsink, the maximum allowable power dissipation is specified either at $T_c = 25^\circ C$ or assuming the use of an infinite heatsink. $P_{C(max)}$ is determined by the internal thermal resistance of the diode as indicated by Equation 2-7.

(2) Contact thermal resistance: $R_{th(c)}$

Contact thermal resistance ($R_{th(c)}$) varies according to the condition of the contact surface between the case of a diode and a heatsink. This condition is greatly affected by factors such as the evenness, coarseness, and area of contact, as well as the attachment of the diode to the heatsink. The influence of the coarseness and unevenness of the contact surface can be reduced by using silicon grease or TIM.

(3) Isolation plate's thermal resistance: $R_{th(s)}$

If it is necessary to provide electrical isolation between a diode and a heatsink, an isolation plate must be inserted between them. The thermal resistance of this isolation plate ($R_{th(s)}$) varies with the materials, thickness, and area of the plate and is not negligible.

For packages isolated by mold resin, the thermal resistance specified for a diode includes the insulator's thermal resistance ($R_{th(s)}$).

(4) Heatsink's thermal resistance: $R_{th(f)}$

The thermal resistance of a heatsink can be considered as the distributed thermal resistance of a heat path from the surface of a heatsink to the ambient air. The thermal resistance of a heatsink depends on the condition of the ambient air, a difference in temperature between the heatsink and the ambient air, and the effective area of the heatsink. It is difficult to mathematically express $R_{th(f)}$. Actually, $R_{th(f)}$ is obtained by measurement. Figure 2.2 shows an example of thermal resistance data measured for a diode at the center of a vertically standing heatsink. Various heatsinks are available from many vendors. Optimal heatsinks should be selected, referring to their technical datasheets.

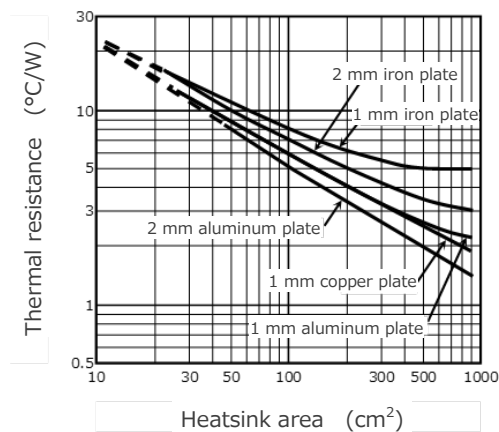

Figure 2.2 Example of thermal resistance-vs-heatsink area curves

2.3. Pulse response of junction temperature

Generally, the thermal impedance of a diode is modeled as a distributed constant circuit as shown in Figure 2.3.

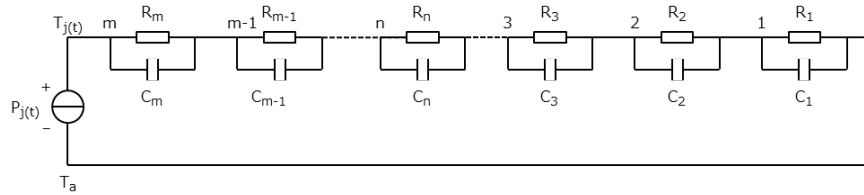

Figure 2.3 Thermal impedance model

When the pulsed power dissipation ($P_{j(t)}$) shown in Figure 2.4 is applied to the circuit of Figure 2.3, a change in junction temperature ($T_{j(t)}$) that appears at the m th parallel RC circuit under stable thermal conditions can be calculated as follows.

In region (a) where $P_{j(t)} = P_0$:

$$T_{j(t)} = \sum_{n=1}^m \{ (P_0 \cdot R_n) - T_{n(min)} \} \left(1 - \exp^{-\frac{t}{C_n \cdot R_n}} \right) + T_{n(min)} \dots \dots \dots (2-8)$$

In region (b) where $P_{j(t)} = 0$

$$T_{j(t)} = \sum_{n=1}^m \{ T_{n(max)} \cdot \exp^{-\frac{t}{C_n \cdot R_n}} \} \dots \dots \dots (2-9)$$

For typical diodes, the actual $P_{j(t)}$ value can be approximated by substituting 4 for m . However, if the C and R values are indefinite, it is difficult to calculate T_j . Therefore, $T_{j(max)}$ is generally estimated using transient thermal resistance as shown in Figure 2.5.

Suppose that a single-shot pulsed rectangular power dissipation (with a pulse width of t and a peak value of P_0) is applied. From the figure, we read the transient thermal impedance ($r_{th(t)}$) at a pulse width of t , and then use Equation 2-10 to calculate $T_{j(max)}$.

$$T_{j(max)} = r_{th(t)} \cdot P_0 + T_a \dots \dots \dots (2-10)$$

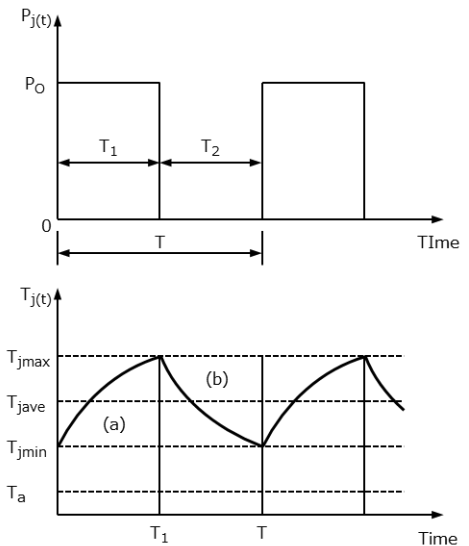

Figure 2.4 Change in junction temperature caused by pulsed power dissipation

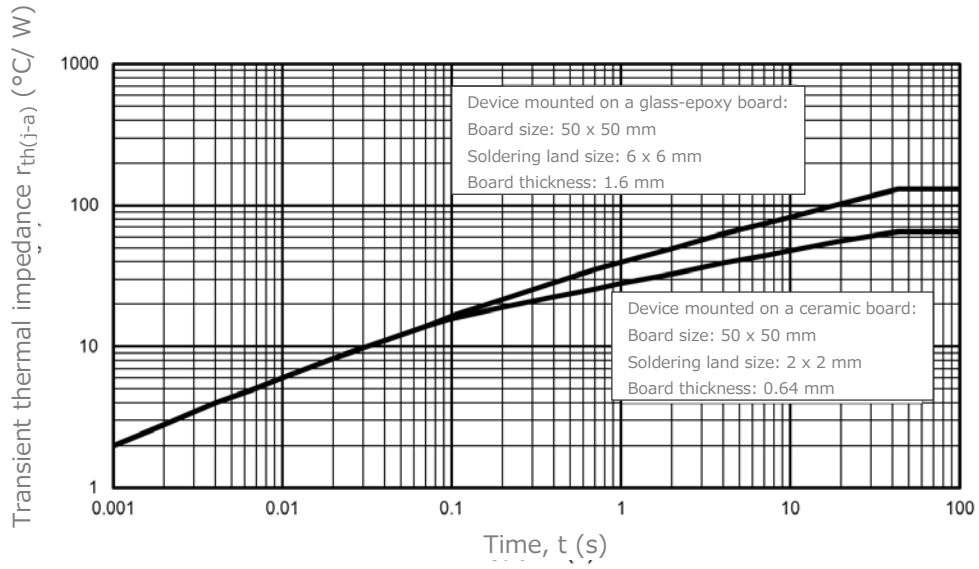

Figure 2.5 Example of transient thermal impedance curves

When a repetitive pulse train with a cyclic period of T is applied as shown in Figure 2.6, $T_{j(max)}$ is given by Equation 2-15 using the superposition theorem.

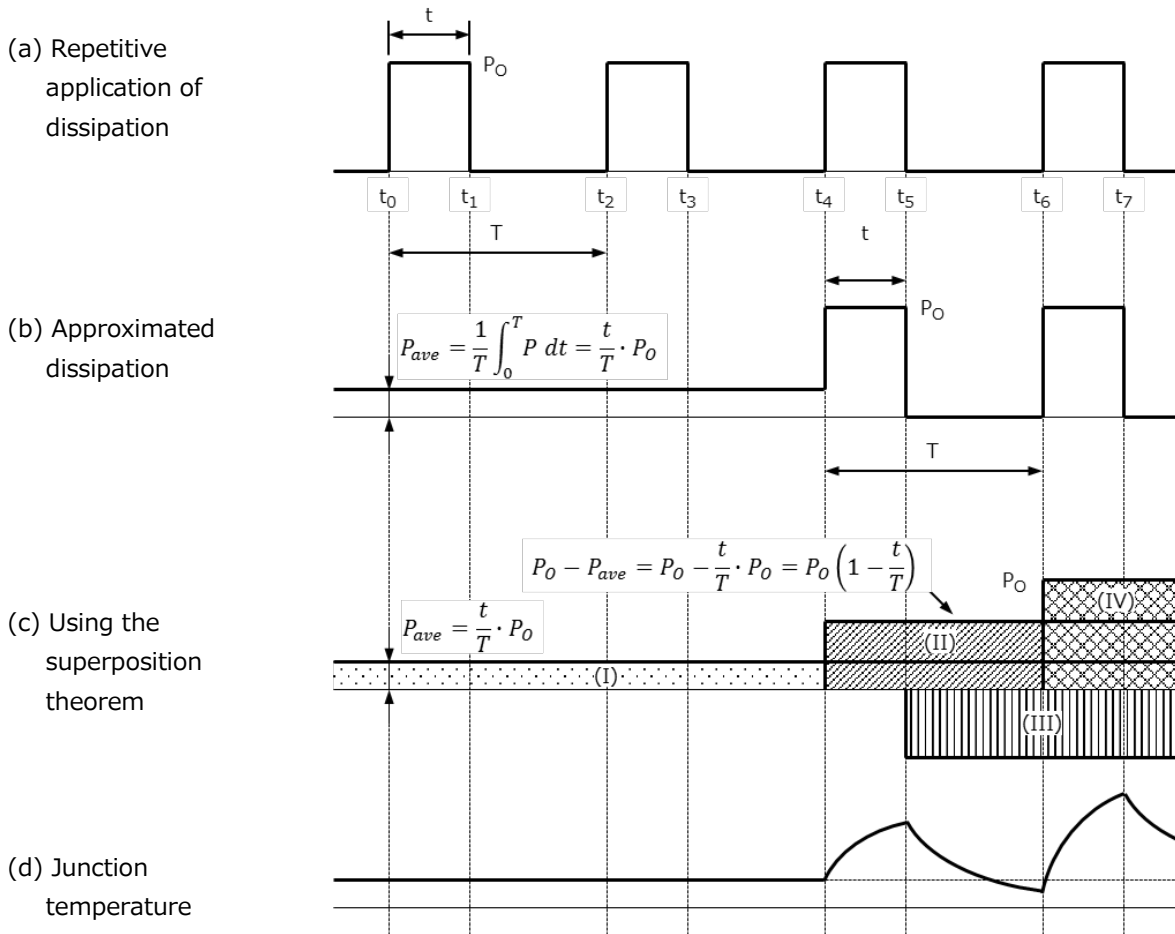

Figure 2.6 Change in junction temperature caused by repetitive application of rectangular pulsed power dissipation at a cyclic period of T

Rise in junction temperature in region (I)

$$\Delta T_{j(I)} = P_o \cdot \frac{t}{T} \cdot R_{th(j-a)} \dots\dots\dots (2-11)$$

Rise in junction temperature in region (II)

$$\Delta T_{j(II)} = P_o \cdot \left(1 - \frac{t}{T}\right) \cdot r_{th(T+t)} \dots\dots\dots (2-12)$$

Rise in junction temperature in region (III)

$$\Delta T_{j(III)} = -P_o \cdot r_{ch(T)} \dots\dots\dots (2-13)$$

Rise in junction temperature in region (IV)

$$\Delta T_{j(IV)} = P_o \cdot r_{th(t)} \dots\dots\dots (2-14)$$

From Equations 2-11 to 2-14, the maximum junction temperature ($T_{j(max)}$) can be calculated as:

$$T_{j(max)} = P_O \cdot \left\{ \frac{t}{T} \cdot R_{th(j-a)} + \left(1 - \frac{t}{T} \right) \cdot r_{th(T+t)} - r_{th(T)} + r_{th(t)} \right\} + T_a \quad \dots\dots\dots (2-15)$$

Great care should be exercised in the thermal design for pulsed power applications to ensure that $T_{j(max)}$ given by Equation 2-15 does not exceed the maximum rated junction temperature of the diode.

The above description assumes that a rectangular waveform is applied to a diode. However, for actual diode applications, the $P_{j(t)}$ waveform seldom becomes rectangular. In such cases, approximate the power dissipation waveform to a rectangular wave as shown in Figure 2.7 and use Equation 2-15 to estimate $T_{j(max)}$.

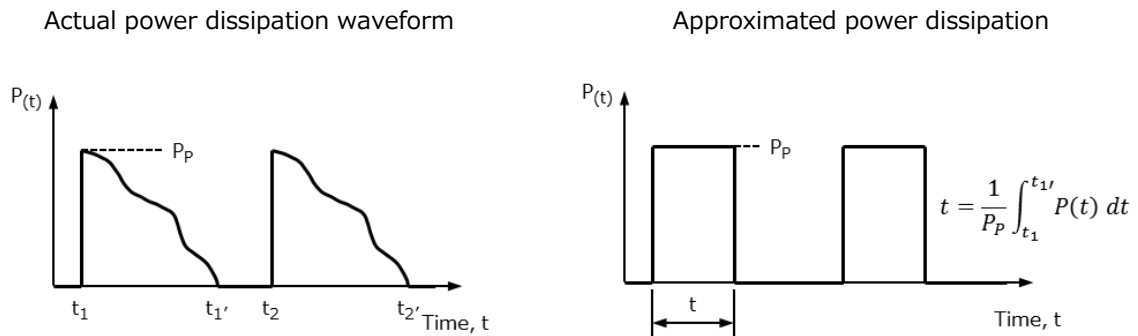

Figure 2.7 Approximation of a power dissipation waveform

Sine and triangular waves can be approximated to rectangular waves as shown in Figure 2.8. To obtain a rectangle with an area equal to a half-sine or triangular area, multiply the peak value of P_p by 0.7 in the case of (a) and (b), and multiply the pulse width by 0.91 for (a) and by 0.71 for (b). In the case of (c) and (d), use the same peak value of P_p , and multiply the pulse width by 0.63 for (c) and by 0.5 for (d).

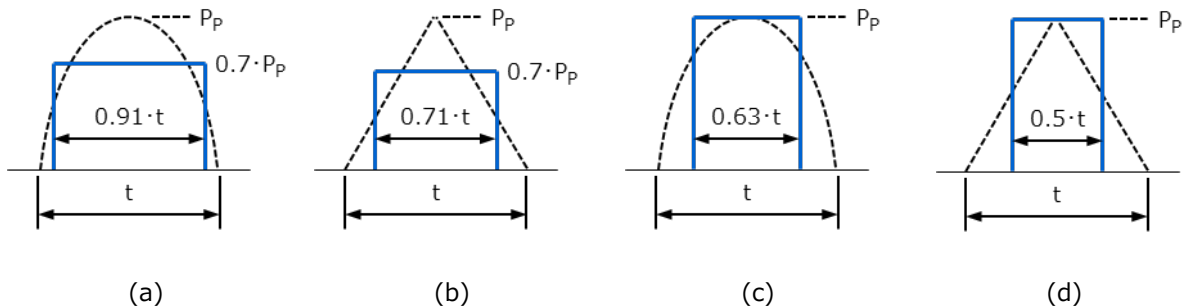

Figure 2.8 Approximating sine and triangular waves to rectangular waves

- To perform a parametric search of switching diodes → [Click Here](#)
- To perform a parametric search of rectifier diodes → [Click Here](#)
- To visit a web page on Schottky barrier diodes → [Click Here](#)
- To perform a parametric search of Schottky barrier diodes → [Click Here](#)
- To visit a web page on SiC Schottky barrier diodes → [Click Here](#)
- To perform a parametric search of SiC Schottky barrier diodes → [Click Here](#)
- To visit a web page on TVS (ESD protection) diodes → [Click Here](#)
- To perform a parametric search of TVS (ESD protection) diodes → [Click Here](#)
- To visit a web page on Zener diodes → [Click Here](#)
- To perform a parametric search of Zener diodes → [Click Here](#)
- To download the application note “SiC Schottky Barrier Diodes” → [Click Here](#)
- To download the application note “SiC Schottky Barrier Diodes: Absolute Maximum Ratings and Electrical Characteristics” → [Click Here](#)
- To download the application note “Selecting Schottky Barrier Diodes for Voltage Boost Circuits” → [Click Here](#)
- To download the application note “Basics of ESD Protection (TVS) Diodes” → [Click Here](#)
- To download the application note “Overvoltage protection device Zener diode and ESD protection diode” → [Click Here](#)
- To visit an FAQ web page on diodes → [Click Here](#)
- Reference Design Center → [Click Here](#)

RESTRICTIONS ON PRODUCT USE

Toshiba Corporation and its subsidiaries and affiliates are collectively referred to as "TOSHIBA". Hardware, software and systems described in this document are collectively referred to as "Product".

- TOSHIBA reserves the right to make changes to the information in this document and related Product without notice.
- This document and any information herein may not be reproduced without prior written permission from TOSHIBA. Even with TOSHIBA's written permission, reproduction is permissible only if reproduction is without alteration/omission.
- Though TOSHIBA works continually to improve Product's quality and reliability, Product can malfunction or fail. Customers are responsible for complying with safety standards and for providing adequate designs and safeguards for their hardware, software and systems which minimize risk and avoid situations in which a malfunction or failure of Product could cause loss of human life, bodily injury or damage to property, including data loss or corruption. Before customers use the Product, create designs including the Product, or incorporate the Product into their own applications, customers must also refer to and comply with (a) the latest versions of all relevant TOSHIBA information, including without limitation, this document, the specifications, the data sheets and application notes for Product and the precautions and conditions set forth in the "TOSHIBA Semiconductor Reliability Handbook" and (b) the instructions for the application with which the Product will be used with or for. Customers are solely responsible for all aspects of their own product design or applications, including but not limited to (a) determining the appropriateness of the use of this Product in such design or applications; (b) evaluating and determining the applicability of any information contained in this document, or in charts, diagrams, programs, algorithms, sample application circuits, or any other referenced documents; and (c) validating all operating parameters for such designs and applications. **TOSHIBA ASSUMES NO LIABILITY FOR CUSTOMERS' PRODUCT DESIGN OR APPLICATIONS.**
- **PRODUCT IS NEITHER INTENDED NOR WARRANTED FOR USE IN EQUIPMENTS OR SYSTEMS THAT REQUIRE EXTRAORDINARILY HIGH LEVELS OF QUALITY AND/OR RELIABILITY, AND/OR A MALFUNCTION OR FAILURE OF WHICH MAY CAUSE LOSS OF HUMAN LIFE, BODILY INJURY, SERIOUS PROPERTY DAMAGE AND/OR SERIOUS PUBLIC IMPACT ("UNINTENDED USE").** Except for specific applications as expressly stated in this document, Unintended Use includes, without limitation, equipment used in nuclear facilities, equipment used in the aerospace industry, lifesaving and/or life supporting medical equipment, equipment used for automobiles, trains, ships and other transportation, traffic signaling equipment, equipment used to control combustions or explosions, safety devices, elevators and escalators, and devices related to power plant. **IF YOU USE PRODUCT FOR UNINTENDED USE, TOSHIBA ASSUMES NO LIABILITY FOR PRODUCT.** For details, please contact your TOSHIBA sales representative or contact us via our website.
- Do not disassemble, analyze, reverse-engineer, alter, modify, translate or copy Product, whether in whole or in part.
- Product shall not be used for or incorporated into any products or systems whose manufacture, use, or sale is prohibited under any applicable laws or regulations.
- The information contained herein is presented only as guidance for Product use. No responsibility is assumed by TOSHIBA for any infringement of patents or any other intellectual property rights of third parties that may result from the use of Product. No license to any intellectual property right is granted by this document, whether express or implied, by estoppel or otherwise.
- **ABSENT A WRITTEN SIGNED AGREEMENT, EXCEPT AS PROVIDED IN THE RELEVANT TERMS AND CONDITIONS OF SALE FOR PRODUCT, AND TO THE MAXIMUM EXTENT ALLOWABLE BY LAW, TOSHIBA (1) ASSUMES NO LIABILITY WHATSOEVER, INCLUDING WITHOUT LIMITATION, INDIRECT, CONSEQUENTIAL, SPECIAL, OR INCIDENTAL DAMAGES OR LOSS, INCLUDING WITHOUT LIMITATION, LOSS OF PROFITS, LOSS OF OPPORTUNITIES, BUSINESS INTERRUPTION AND LOSS OF DATA, AND (2) DISCLAIMS ANY AND ALL EXPRESS OR IMPLIED WARRANTIES AND CONDITIONS RELATED TO SALE, USE OF PRODUCT, OR INFORMATION, INCLUDING WARRANTIES OR CONDITIONS OF MERCHANTABILITY, FITNESS FOR A PARTICULAR PURPOSE, ACCURACY OF INFORMATION, OR NONINFRINGEMENT.**
- Do not use or otherwise make available Product or related software or technology for any military purposes, including without limitation, for the design, development, use, stockpiling or manufacturing of nuclear, chemical, or biological weapons or missile technology products (mass destruction weapons). Product and related software and technology may be controlled under the applicable export laws and regulations including, without limitation, the Japanese Foreign Exchange and Foreign Trade Law and the U.S. Export Administration Regulations. Export and re-export of Product or related software or technology are strictly prohibited except in compliance with all applicable export laws and regulations.
- Please contact your TOSHIBA sales representative for details as to environmental matters such as the RoHS compatibility of Product. Please use Product in compliance with all applicable laws and regulations that regulate the inclusion or use of controlled substances, including without limitation, the EU RoHS Directive. **TOSHIBA ASSUMES NO LIABILITY FOR DAMAGES OR LOSSES OCCURRING AS A RESULT OF NONCOMPLIANCE WITH APPLICABLE LAWS AND REGULATIONS.**