

**TOSHIBA**

**32-bit TX System RISC  
TX03 Series**

**TMPM330FYWFG**

**Rev 1.02**

**TOSHIBA CORPORATION**

**Semiconductor & Storage Products Company**

## Table of Contents

Table of Contents.....	i
1. Overview and Features.....	2
1.1 Features .....	2
1.2 Block Diagram .....	5
2 Pin Layout and Pin Functions .....	6
2.1 Pin Layout (Top view).....	6
2.2 Pin names and Functions.....	9
2.2.1 Sorted by Pin .....	9
2.2.2 Sorted by Port.....	14
2.3 Pin Names and Power Supply Pins .....	19
2.4 Pin Numbers and Power Supply Pins .....	19
3 Processor Core and Memory Map.....	20
3.1 Processor Core .....	20
3.2 Configurable Options .....	20
3.3 Exceptions/ Interruptions.....	20
3.2.1 Number of Interrupt Inputs.....	20
3.2.2 Number of Priority Level Interrupt Bits .....	21
3.2.3 SysTick .....	21
3.2.4 SYSRESETREQ.....	21
3.2.5 LOCKUP .....	21
3.2.6 Auxiliary Fault Status register.....	21
3.4 Events .....	21
3.5 Power Management .....	22
3.6 Exclusive access .....	22
4 Debug Interface .....	23
4.1 Specification Overview .....	23
4.2 Features of SWJ-DP .....	23
4.3 Features of ETM .....	23
4.4 Pin Functions.....	23
4.5 Connection with a Debug Tool .....	24
5 Memory Map .....	25
5.1 Memory Map of the TPM330FYWFG.....	26

6	Reset.....	27
6.1	Cold Reset.....	27
6.2	Warm Reset .....	28
6.2.1	Reset Period .....	28
6.3	After Reset .....	28
7	Clock/Mode Control .....	29
7.1	Features .....	29
7.2	Registers .....	30
7.2.1	Register List.....	30
7.2.2	Detailed Description of Registers .....	31
7.3	Clock Control.....	36
7.3.1	Clock Type .....	36
7.3.2	Initial Values after Reset.....	36
7.3.3	Clock Multiplication Circuit (PLL).....	38
7.3.4	Warm-up Function .....	39
7.3.5	System Clock.....	41
7.3.6	Prescaler Clock Control.....	41
7.3.7	System Clock Pin Output Function.....	42
7.4	Modes and Mode Transitions .....	43
7.4.1	Mode Transitions .....	43
7.5	Operation Modes.....	44
7.5.1	NORMAL Mode .....	44
7.5.2	SLOW Mode .....	44
7.6	Low Power Consumption Modes .....	44
7.6.1	IDLE Mode.....	45
7.6.2	SLEEP Mode .....	45
7.6.3	STOP Mode .....	45
7.6.4	Low power Consumption Mode Setting.....	47
7.6.5	Operational State in Each Mode.....	47
7.6.6	Releasing the Low Power Consumption Mode .....	48
7.6.7	Warm-up.....	49
7.6.8	Clock Operations in Mode Transition .....	50
8	Exceptions .....	52
8.1	Overview .....	52
8.1.1	Exception Types .....	52

8.1.2	Handling Flowchart .....	53
8.2	Reset Exceptions .....	59
8.3	Non-Maskable Interrupts (NMIs) .....	59
8.4	SysTick .....	60
8.5	Interrupts .....	61
8.5.1	Interrupt Sources .....	61
8.5.2	Interrupt Handling .....	65
8.6	Exception/Interrupt-Related Registers .....	72
8.6.1	Register List .....	72
8.6.2	NVIC Registers .....	73
8.6.3	NVIC Registers .....	95
9	Input/Output Ports .....	102
9.1	Port registers .....	102
9.2	Port Functions .....	103
9.2.1	Port States in STOP Mode .....	103
9.2.2	Precaution for Mode Transition .....	103
9.2.3	Port A (PA0~PA7) .....	104
9.2.4	Port B (PB0~PB7) .....	106
9.2.5	Port C (PC0~PC3) .....	108
9.2.6	Port D (PD0~PD7) .....	109
9.2.7	Port E (PE0~PE6) .....	110
9.2.8	Port F (PF0~PF7) .....	112
9.2.9	Port G (PG0~PG7) .....	114
9.2.10	Port H (PH0~PH7) .....	116
9.2.11	Port I (PI0~PI7) .....	118
9.2.12	Port J (PJ0~PJ7) .....	119
9.2.13	Port K (PK0~PK2) .....	121
9.3	Block Diagrams of Ports .....	123
9.3.1	Port Types .....	123
9.3.2	Type T1 .....	124
9.3.3	Type T2 .....	125
9.3.4	Type T3 .....	126
9.3.5	Type T4 .....	127
9.3.6	Type T5 .....	128
9.3.7	Type T6 .....	129
9.3.8	Type T7 .....	130

9.3.9	Type T8.....	131
9.3.10	Type T9.....	132
9.3.11	Type T10.....	133
9.3.12	Type T11.....	134
9.3.13	Type T12.....	135
9.3.14	Type T13.....	136
9.3.15	Type T14.....	137
9.3.16	Type T15.....	138
9.3.17	Type T16.....	139
9.3.18	Type T17.....	140
9.3.19	Type T18.....	141
10	16-bit Timer/Event Counters (TMRBs).....	142
10.1	Outline.....	142
10.2	Differences in the Specifications.....	143
10.3	Configuration.....	145
10.4	Registers.....	147
10.4.1	TMRB registers.....	147
10.5	Description of Operations for Each Circuit.....	159
10.5.1	Prescaler.....	159
10.5.2	Up-counter (UC0).....	164
10.5.3	Timer registers (TB0RG0, TB0RG1).....	164
10.5.4	Capture.....	166
10.5.5	Capture Registers (TB0CP0H/L, TB0CP1H/L).....	166
10.5.6	Up-counter capture register (TB0UCH/L).....	166
10.5.7	Comparators (CP0, CP1).....	166
10.5.8	Timer Flip-flop (TB0FF0).....	166
10.5.9	Capture interrupt (INTCAP00, INTCAP01).....	166
10.6	Description of Operations for Each Mode.....	167
10.6.1	16-bit Interval Timer Mode.....	167
10.6.2	16-bit Event Counter Mode.....	167
10.6.3	16-bit Programmable Square Wave Output Mode (PPG).....	168
10.7	Timer synchronous mode.....	170
10.8	Applications using the Capture Function.....	171
11	Serial Channel (SIO).....	175
11.1	Features.....	175

11.2	Block Diagram (Channel 0).....	178
11.3	Operation of Each Circuit (Channel 0).....	179
11.3.1	Prescaler.....	179
11.3.2	Baud Rate Generator .....	184
11.3.3	Serial Clock Generation Circuit .....	188
11.3.4	Receive Counter .....	188
11.3.5	Receive Control Unit.....	188
11.3.6	Receive Buffer .....	188
11.3.7	Receive FIFO Buffer .....	190
11.3.8	Receive FIFO Operation.....	190
11.3.9	Transmit Counter .....	192
11.3.10	Transmit Control Unit.....	192
11.3.11	Transmit Buffer .....	194
11.3.12	Transmit FIFO Buffer .....	195
11.3.13	Transmit FIFO Operation .....	195
11.3.14	Parity Control Circuit.....	197
11.3.15	Error Flag .....	197
11.3.16	Direction of Data Transfer.....	198
11.3.17	Stop Bit Length .....	198
11.3.18	Status Flag .....	198
11.3.19	Configurations of Transmit/Receive Buffer .....	199
11.3.20	Software reset.....	199
11.3.21	Signal Generation Timing .....	200
11.4	Register Description (Only for Channel 0) .....	201
11.4.1	Enable register .....	201
11.4.2	Buffer register .....	201
11.4.3	Control register .....	202
11.4.4	Mode control register 0.....	203
11.4.5	Mode control register 1.....	204
11.4.6	Mode control register 2.....	205
11.4.7	Baud rate generator control register(SC0BRCCR) Baud rate generator control register 2(SC0BRADD).....	206
11.4.8	FIFO configuration register .....	208
11.4.9	RX FIFO configuration register.....	209
11.4.10	TX FIFO configuration register .....	210
11.4.11	RX FIFO status register .....	211

11.4.12	TX FIFO status register .....	211
11.5	Operation in Each Mode .....	212
11.5.1	Mode 0 (I/O interface mode).....	212
11.5.2	Mode 1 (7-bit UART Mode).....	222
11.5.3	Mode 2 (8-bit UART Mode).....	223
11.5.4	Mode 3 (9-bit UART).....	224
12	Serial Bus Interface (SBI) .....	226
12.1	Configuration .....	227
12.2	Control .....	228
12.3	I2C Bus Mode Data Formats.....	229
12.4	Control Registers in the I2C Bus Mode.....	230
12.5	Control in the I2C Bus Mode .....	239
12.5.1	Setting the Acknowledgement Mode .....	239
12.5.2	Setting the Number of Bits per Transfer .....	239
12.5.3	Serial Clock.....	239
12.5.4	Slave Addressing and Address Recognition Mode .....	240
12.5.5	Configuring the SBI as a Master or a Slave .....	240
12.5.6	Configuring the SBI as a Transmitter or a Receiver .....	241
12.5.7	Generating Start and Stop Conditions .....	242
12.5.8	Interrupt Service Request and Release .....	243
12.5.9	Serial Bus Interface Operating Modes .....	243
12.5.10	Lost-arbitration Detection Monitor .....	243
12.5.11	Slave Address Match Detection Monitor.....	244
12.5.12	General-call Detection Monitor .....	245
12.5.13	Last Received Bit Monitor .....	245
12.5.14	Software Reset .....	246
12.5.15	Serial Bus Interface Data Buffer Register (SBIxDBR).....	246
12.5.16	I2C Bus Address Register (SBIxI2CAR).....	246
12.5.17	IDLE Setting Register (SBIxBR0) .....	246
12.6	Data Transfer Procedure in the I2C Bus Mode .....	247
12.6.1	Device Initialization .....	247
12.6.2	Generating the Start Condition and a Slave Address .....	248
12.6.3	Transferring a Data Word .....	250
12.6.4	Generating the Stop Condition .....	255
12.6.5	Restart Procedure.....	256
12.7	Control in the Clock-synchronous 8-bit SIO Mode.....	257

12.7.1	Serial Clock.....	261
12.7.2	Transfer Modes.....	263
13	Consumer Electronics Control (CEC).....	268
13.1	Outline.....	268
13.1.1	Reception.....	268
13.1.2	Transmission.....	268
13.1.3	Precations.....	268
13.2	Registers.....	269
13.2.1	Control Registers and Addresses.....	269
13.2.2	CEC Enable Register [CECEN].....	270
13.2.3	Logical Address Register [CECADD].....	270
13.2.4	Software Reset Register [CECRESET].....	271
13.2.5	Receive Enable Register [CECREN].....	271
13.2.6	Receive Buffer Register [CECRBUF].....	272
13.2.7	Receive Control Register 1 [CECRCR1].....	273
13.2.8	Receive Control Register 2 [CECRCR2].....	275
13.2.9	Receive Control Register 3 [CECRCR3].....	276
13.2.10	Transmit Enable Register [CECTEN].....	278
13.2.11	Transmit Buffer Register [CECTBUF].....	279
13.2.12	Transmit Control Register [CECTCR].....	280
13.2.13	Receive Interrupt Status Register [CECRSTAT].....	282
13.2.14	Transmit Interrupt Status Register [CECTSTAT].....	283
13.2.15	CEC Sampling Clock Select Register [CECFSEL].....	284
13.3	Operations.....	285
13.3.1	Reception.....	285
13.3.2	Transmission.....	296
13.3.3	Software Reset.....	302
14	Remote control signal preprocessor (RMC).....	303
14.1	Basic operation.....	303
14.1.1	Reception of Remote Control Signal.....	303
14.2	Registers.....	304
14.2.1	Register Map.....	304
14.2.2	Remote Control Enable Register [RMCEN].....	305
14.2.3	Remote Control Receive Enable Register [RMCREN].....	305
14.2.4	Remote Control Receive Data Buffer Register 1 [RMCRBUF1].....	306

14.2.5	Remote Control Receive Data Buffer Register 2 [RMCRBUF2].....	307
14.2.6	Remote Control Receive Data Buffer Register 3 [RMCRBUF3].....	307
14.2.7	Remote Control Receive Control Register 1 [RMCRCR1].....	308
14.2.8	Remote Control Receive Control Register 2 [RMCRCR2].....	310
14.2.9	Remote Control Receive Control Register 3 [RMCRCR3].....	311
14.2.10	Remote Control Receive Control Register 4 [RMCRCR4].....	312
14.2.11	Remote Control Receive Status Register [RMCRSTAT].....	313
14.3	Operation Description.....	314
14.3.1	Reception of Remote Control Signal.....	314
15	Analog/Digital Converter.....	326
15.1	Registers.....	327
15.2	Registers Description.....	328
15.3	Conversion Clock.....	340
15.4	Description of Operations.....	341
15.4.1	Analog Reference Voltage.....	341
15.4.2	Selecting the Analog Input Channel.....	341
15.4.3	Starting A/D Conversion.....	342
15.4.4	A/D Conversion Modes and A/D Conversion Completion Interrupts.....	344
15.5	High-priority Conversion Mode.....	347
15.6	A/D Monitor Function.....	347
15.7	Storing and Reading A/D Conversion Results.....	347
15.8	Data Polling.....	348
16	Watchdog Timer (Runaway Detection Timer).....	349
16.1	Configuration.....	349
16.2	Watchdog Timer Interrupt.....	350
16.3	Control Registers.....	351
16.3.1	Watchdog Timer Mode Register (WDMOD).....	351
16.3.2	Watchdog Timer Control Register (WDCR).....	352
16.4	Control Register.....	354
17	Real Time Clock (RTC).....	355
17.1	Functions.....	355
17.2	Block Diagram.....	355
17.3	Control Registers.....	356
17.4	Detailed Description of Control Register.....	357

17.5	Operational Description.....	365
17.5.1	Reading clock data .....	365
17.5.2	Writing clock data .....	366
17.5.3	Entering the Low Power Consumption Mode.....	367
17.6	Alarm Function .....	368
18	Flash Memory Operation .....	370
18.1	Flash Memory.....	370
18.1.1	Features.....	370
18.1.2	Block Diagram of the Flash Memory Section .....	371
18.2	Operation Mode .....	372
18.2.1	Reset Operation .....	373
18.2.2	User Boot Mode (Single chip mode) .....	374
18.2.3	Single Boot Mode .....	381
18.3	On-board Programming of Flash Memory (Rewrite/Erase) .....	412
18.3.1	Flash Memory.....	412
19	ROM protection .....	430
19.1	Outline .....	430
19.2	Features .....	430
19.2.1	Write/ erase-protection function.....	430
19.2.2	Security function .....	430
19.3	Register .....	431
19.4	Writing and erasing .....	433
19.4.1	Protection bits .....	433
19.4.2	Security bit .....	433
20	Electrical Characteristics.....	434
20.1	Absolute Maximum Ratings .....	434
20.2	DC Electrical Characteristics (1/2) .....	435
20.3	DC Electrical Characteristics (2/2) .....	436
20.4	10-bit ADC Electrical Characteristics .....	437
20.5	AC Electrical Characteristics.....	438
21.5.1	Serial Channel Timing (SIO).....	438
21.5.2	SBI (I2C) .....	440
21.5.3	Event Counter.....	444
21.5.4	Capture .....	444

21.5.5	External Interrupts .....	444
21.5.6	NMI .....	445
21.5.7	SCOUT Pin AC Characteristic .....	445
21.5.8	Debug Communication .....	446
21.5.9	TRACE Output.....	447
20.6	Oscillation Circuit .....	448
20.7	Handling Precaution.....	449
21.7.1	Notice of Power supply.....	449
21.7.1.1	Notice if Power-on .....	449
21.7.1.2	Notice of Power on again.....	449
21	Port Section Equivalent Circuit Schematic .....	450
22	Package .....	455
	RESTRICTIONS ON PRODUCT USE .....	457

\*\*\*\*\*  
ARM, ARM Powered, AMBA, ADK, ARM9TDMI, TDMI, PrimeCell, RealView, Thumb, Cortex, Coresight, ARM9, ARM926EJ-S, Embedded Trace Macrocell, ETM, AHB, APB, and KEIL are registered trademarks or trademarks of ARM Limited in the EU and other countries.  
\*\*\*\*\*



**32-bit RISC Microcontroller – TX03 Series****TMPM330FYWFG****1. Overview and Features**

The TX03 series is a 32-bit RISC microcontroller series with an ARM Cortex™-M3 microcontroller core.

Features of the TMPM330 is as follows:

**1.1 Features****(1) ARM Cortex-M3 microcontroller core****1) Improved code efficiency has been realized through the use of Thumb®-2 instruction**

- New 16-bit Thumb instructions for improved program flow
- New 32-bit Thumb instructions for improved performance
- Auto-switching between 32-bit instruction and 16-bit instruction is executed by compiler.

**2) Both high performance and low power consumption have been achieved.****-High performance**

- A 32-bit multiplication ( $32 \times 32 = 32$  bit) can be executed with one clock.
- Division takes between 2 and 12 cycles depending on dividend and divisor

**-Low power consumption**

- Optimized design using a low power consumption library
- Standby function that stops the operation of the microcontroller core

**3) High-speed interrupt response suitable for real-time control**

- An interruptible long instruction.
- Stack push automatically handled by hardware.

- (2) On Chip program memory and data memory

Product name	On chip Flash ROM	On chip RAM
TMPM330FYWFG	256Kbyte	16Kbyte

- (3) 16-bit timer : 10 channels
- 16-bit interval timer mode
  - 16-bit event counter mode
  - 16-bit PPG output
  - Input capture function
- (4) Real time clock (RTC) : 1 channel
- Clock (hour, minute and second)
  - Calendar (Month, week, date and leap year)
  - Time correction + or - 30 seconds (by software)
  - Alarm (Alarm output)
  - Alarm interrupt
- (5) Watchdog timer : 1 channel
- Watchdog timer out
- (6) General-purpose serial interface : 3 channels
- Either UART mode or synchronous mode can be selected (4byte FIFO equipped)
- (7) Serial bus interface : 3 channels
- Either I<sup>2</sup>C bus mode or synchronous mode can be selected.
- (8) CEC : 1 channel
- Transmission and reception per 1 byte.
- (9) Remote control signal preprocessor : 2 channels
- Can receive up to 72bit data at a time
- (10) 10-bit A/D converter : 12 channels
- Start by an internal or external timer trigger
  - Fixed channel/scan mode
  - Single/repeat mode
  - AD monitoring 2ch
  - Conversion speed 1.15usec(@fsys = 40MHz)
- (11) Interrupt source
- Internal: 42 factors...The order of precedence can be set over 7 levels (except the watchdog timer interrupt).
  - External: 8 factors...The order of precedence can be set over 7 levels.
- (12) Input/ output ports
- 78 pins

- (13) Standby mode
  - Standby modes :IDLE, SLOW, SLEEP, STOP
  - Sub clock operation(32.768kHz) :SLOW, SLEEP
  
- (14) Clock generator
  - On-chip PLL (quadrupled)
  - Clock gear function: The high-speed clock can be divided into 1/1, 1/2, 1/4 or 1/8.
  
- (15) Endian
  - Little endian
  
- (16) Maximum operating frequency
  - 40MHz
  
- (17) Operating voltage range
  - 2.7V~3.6V (with on-chip regulator)
  
- (18) Temperature range
  - -40~85 degrees (except during Flash writing/ erasing)
  - 0~70 degrees (during Flash writing/ erasing)
  
- (19) Package
  - LQFP100-P-1414-0.50H (14mm × 14mm, 0.5mm pitch)

### 1.2 Block Diagram

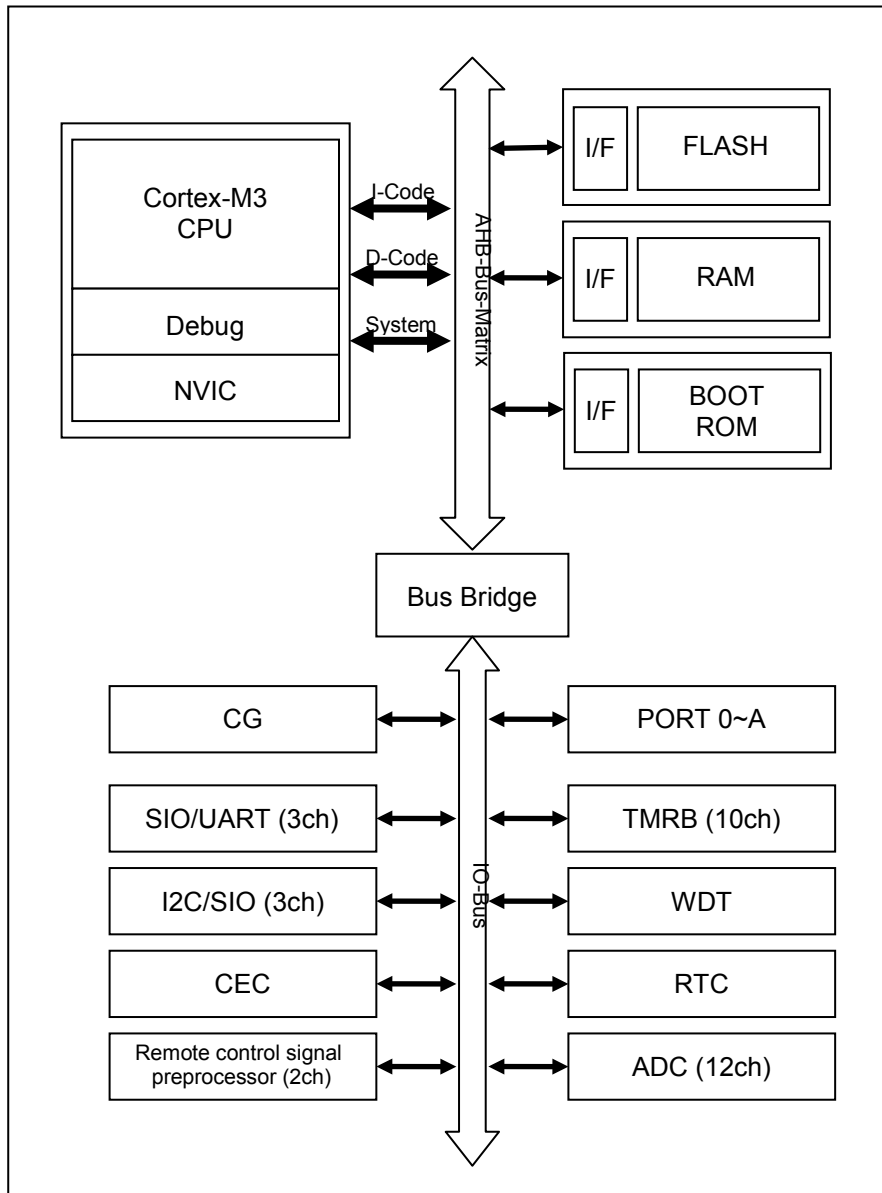

Fig. 1-1 Block Diagram

## 2 Pin Layout and Pin Functions

This chapter describes the pin layout, pin names and pin functions of TMPM330.

### 2.1 Pin Layout (Top view)

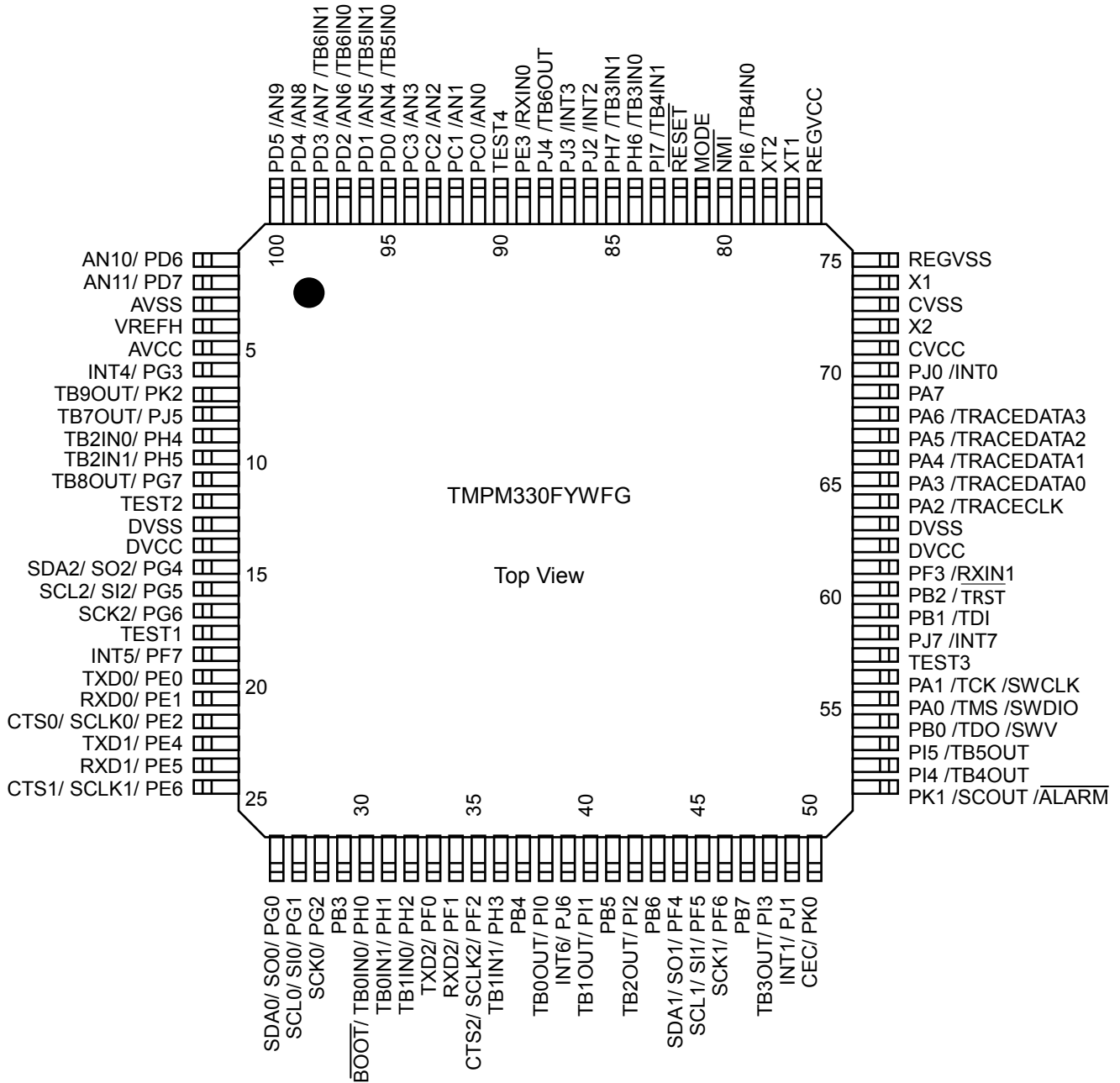

Fig.2-1 Pin Layout (LQFP100)

Table2-1 Pin Numbers and Names (1/2)

Pin No.	Pin name	Pin No.	Pin name
1	PD6, AN10	26	PG0, SO0, SDA0
2	PD7, AN11	27	PG1, SI0, SCL0
3	AVSS	28	PG2, SCK0
4	VREFH	29	PB3
5	AVCC	30	PH0, TB0IN0, $\overline{\text{BOOT}}$
6	PG3, INT4	31	PH1, TB0IN1
7	PK2, TB9OUT	32	PH2, TB1IN0
8	PJ5, TB7OUT	33	PF0, TXD2
9	PH4, TB2IN0	34	PF1, RXD2
10	PH5, TB2IN1	35	PF2, SCLK2, CTS2
11	PG7, TB8OUT	36	PH3, TB1IN1
12	TEST2	37	PB4
13	DVSS	38	PI0, TB0OUT
14	DVCC	39	PJ6, INT6
15	PG4, SO2, SDA2	40	PI1, TB1OUT
16	PG5, SI2, SCL2	41	PB5
17	PG6, SCK2	42	PI2, TB2OUT
18	TEST1	43	PB6
19	PF7, INT5	44	PF4, SO1, SDA1
20	PE0, TXD0	45	PF5, SI1, SCL1
21	PE1, RXD0	46	PF6, SCK1
22	PE2, SCLK0, CTS0	47	PB7
23	PE4, TXD1	48	PI3, TB3OUT
24	PE5, RXD1	49	PJ1, INT1
25	PE6, SCLK1, CTS1	50	PK0, CEC

Table2-1 Pin Numbers and Names (2/2)

Pin No.	Pin name	Pin No.	Pin name
51	PK1, SCOUT, $\overline{\text{ALARM}}$	76	REGVCC
52	PI4, TB4OUT	77	XT1
53	PI5, TB5OUT	78	XT2
54	PB0, TDO, SWV	79	PI6, TB4IN0
55	PA0, TMS, SWDIO	80	$\overline{\text{NMI}}$
56	PA1, TCK, SWCLK	81	MODE
57	TEST3	82	$\overline{\text{RESET}}$
58	PJ7, INT7	83	PI7, TB4IN1
59	PB1, TDI	84	PH6, TB3IN0
60	PB2, $\overline{\text{TRST}}$	85	PH7, TB3IN1
61	PF3, RXIN1	86	PJ2, INT2
62	DVCC	87	PJ3, INT3
63	DVSS	88	PJ4, TB6OUT
64	PA2, TRACECLK	89	PE3, RXIN0
65	PA3, TRACEDATA0	90	TEST4
66	PA4, TRACEDATA1	91	PC0, AN0
67	PA5, TRACEDATA2	92	PC1, AN1
68	PA6, TRACEDATA3	93	PC2, AN2
69	PA7	94	PC3, AN3
70	PJ0, INT0	95	PD0, AN4, TB5IN0
71	CVCC	96	PD1, AN5, TB5IN1
72	X2	97	PD2, AN6, TB6IN0
73	CVSS	98	PD3, AN7, TB6IN1
74	X1	99	PD4, AN8
75	REGVSS	100	PD5, AN9

## 2.2 Pin names and Functions

Table2-2 and Table2-3 sort the input and output pins of the TMPM330 by pin or port. Each table includes alternate pin names and functions for multi-function pins.

### 2.2.1 Sorted by Pin

Table2-2 Pin Names and Functions Sorted by Pin (1/5)

Type	# of Pins	Pin Name	Input/ Output	Function	Programmable Pull up/ Pull down	Schmitt trigger	Programmable Open Drain Output
Function	1	PD6 AN10	I I	Input port Analog input	Pull up	-	-
	2	PD7 AN11	I I	Input port Analog input	Pull up	-	-
PS	3	AVSS	I	A/D converter: GND pin (0V) Tie AVSS to power supply even if the A/D converter is not used.	-	-	-
	4	VREFH	I	Supplying the A/D converter with a reference power supply. Tie VREFH to power supply even if the A/D converter is not used.	-	-	-
	5	AVCC	I	Supplying the A/D converter with a power supply. Tie AVCC to power supply even if the A/D converter is not used.	-	-	-
Function	6	PG3 INT4	I/O I	I/O port Interrupt request pin	Pull up	○ w/ noise filter	○
	7	PK2 TB9OUT	I/O O	I/O port Timer B output	Pull up	-	-
	8	PJ5 TB7OUT	I/O O	I/O port Timer B output	Pull up	-	-
	9	PH4 TB2IN0	I/O I	I/O port Inputting the timer B capture trigger	Pull up	○	-
	10	PH5 TB2IN1	I/O I	I/O port Inputting the timer B capture trigger	Pull up	○	-
	11	PG7 TB8OUT	I/O O	I/O port Timer B output	Pull up	-	○
Test	12	TEST2	-	TEST pin: Not connected.	-	-	-
PS	13	DVSS	-	GND pin	-	-	-
	14	DVCC	-	Power supply pin	-	-	-
Function	15	PG4	I/O	I/O port	Pull up	○	○
		SDA2/ SO2	I/O O	If the serial bus interface operates -in the I2C mode : data pin -in the SIO mode: data pin			
	16	PG5	I/O	I/O port	Pull up	○	○
SCL2/ SI2		I/O I	If the serial bus interface operates -in the I2C mode : clock pin -in the SIO mode: data pin				
17	PG6	I/O	I/O port	Pull up	○	○	
	SCK2	I/O	Inputting and outputting a clock if the serial bus interface operates in the SIO mode.				
Test	18	TEST1	-	TEST pin: Not connected.	-	-	-
Function	19	PF7 INT5	I/O I	I/O port Interrupt request pin	Pull up	○ w/ noise filter	○

Table2-2 Pin Names and Functions Sorted by Pin (2/5)

Type	# of Pins	Pin Name	Input/Output	Function	Programmable Pull-up/Pull down	Schmitt trigger	Programmable Open Drain Output
Function	20	PE0 TXD0	I/O O	I/O port Sending serial data	Pull up	-	○
	21	PE1 RXD0	I/O I	I/O port Receiving serial data	Pull up	○	○
	22	PE2 SCLK0 CTS0	I/O I/O I	I/O port Serial clock input/ output Handshake input pin	Pull up	○	○
	23	PE4 TXD1	I/O O	I/O port Sending serial data	Pull up	-	○
	24	PE5 RXD1	I/O I	I/O port Receiving serial data	Pull up	○	○
	25	PE6 SCLK1 CTS1	I/O I/O I	I/O port Serial clock input/ output Handshake input pin	Pull up	○	○
	26	PG0 SDA0/ SO0	I/O I/O O	I/O port If the serial bus interface operates -in the I2C mode : data pin -in the SIO mode: data pin	Pull up	○	○
	27	PG1 SCL0/ SIO	I/O I/O I	I/O port If the serial bus interface operates -in the I2C mode : clock pin -in the SIO mode: data pin	Pull up	○	○
	28	PG2 SCK0	I/O I/O	I/O port Inputting and outputting a clock if the serial bus interface operates in the SIO mode.	Pull up	○	○
	29	PB3	I/O	I/O port	Pull up	-	-
Function/ Control	30	PH0 TB0IN0 $\overline{\text{BOOT}}$	I/O I I	I/O port Inputting the timer B capture trigger Setting a single boot mode: This pin goes into single boot mode by sampling "L" at the rise of a reset signal.	Pull up	○	-
Function	31	PH1 TB0IN1	I/O I	I/O port Inputting the timer B capture trigger	Pull up	○	-
	32	PH2 TB1IN0	I/O I	I/O port Inputting the timer B capture trigger	Pull up	○	-
	33	PF0 TXD2	I/O O	I/O port Sending serial data	Pull up	-	○
	34	PF1 RXD2	I/O I	I/O port Receiving serial data	Pull up	○	○
	35	PF2 SCLK2 CTS2	I/O I/O I	I/O port Serial clock input/ output Handshake input pin	Pull up	○	○
	36	PH3 TB1IN1	I/O I	I/O port Inputting the timer B capture trigger	Pull up	○	-
	37	PB4	I/O	I/O port	Pull up	-	-
	38	PI0 TB0OUT	I/O O	I/O port Timer B output	Pull up	-	-
	39	PJ6 INT6	I/O I	I/O port Interrupt request pin	Pull up	○ w/ noise filter	-

Table2-2 Pin Names and Functions Sorted by Pin (3/5)

Type	# of Pins	Pin Name	Input/Output	Function	Programmable Pull-up/Pull down	Schmitt trigger	Programmable Open Drain Output
Function	40	PI1 TB1OUT	I/O O	I/O port Timer B output	Pull up	-	-
	41	PB5	I/O	I/O port	Pull up	-	-
	42	PI2 TB2OUT	I/O O	I/O port Timer B output	Pull up	-	-
	43	PB6	I/O	I/O port	Pull up	-	-
	44	PF4 SDA1/ SO1	I/O O	I/O port If the serial bus interface operates -in the I2C mode : data pin -in the SIO mode: data pin	Pull up	○	○
	45	PF5 SCL1/ SI1	I/O I	I/O port If the serial bus interface operates -in the I2C mode : clock pin -in the SIO mode: data pin	Pull up	○	○
	46	PF6 SCK1	I/O I/O	I/O port Inputting and outputting a clock if the serial bus interface operates in the SIO mode.	Pull up	○	○
	47	PB7	I/O	I/O port	Pull up	-	-
	48	PI3 TB3OUT	I/O O	I/O port Timer B output	Pull up	-	-
	49	PJ1 INT1	I/O I	I/O port Interrupt request pin	Pull up	○ w/ noise filter	-
	50	PK0 CEC	I/O I/O	I/O port CEC pin	-	○	● (Note 4)
	51	PK1 SCOUT ALARM	I/O O O	I/O port System clock output Alarm output	Pull up	-	-
	52	PI4 TB4OUT	I/O O	I/O port Timer B output	Pull up	-	-
	53	PI5 TB5OUT	I/O O	I/O port Timer B output	Pull up	-	-
Function/ Debug	54	PB0 TDO/SWV	I/O O	I/O port Debug pin	Pull up	-	-
	55	PA0 TMS/SWDIO	I/O I/O	I/O port Debug pin	Pull up	○	-
	56	PA1 TCK/ SWCLK	I/O I	I/O port Debug pin	Pull down	-	-
Test	57	TEST3	-	TEST pin: Not connected.	-	-	-
Function	58	PJ7 INT7	I/O I	I/O port Interrupt request pin	Pull up	○ w/ noise filter	-
Function/ Debug	59	PB1 TDI	I/O I	I/O port Debug pin	Pull up	-	-
	60	PB2 TRST	I/O I	I/O port Debug pin	Pull up	○	-
Function	61	PF3 RXIN1	I/O I	I/O port Inputting signal to remote controller	Pull up	○	○
PS	62	DVCC	-	Power supply pin	-	-	-
	63	DVSS	-	GND pin	-	-	-

Table2-2 Pin Names and Functions Sorted by Pin (4/5)

Type	# of Pins	Pin Name	Input/Output	Function	Programmable Pull-up/Pull down	Schmitt trigger	Programmable Open Drain Output
Function/Debug	64	PA2 TRACECLK	I/O O	I/O port Debug pin	Pull up	-	-
	65	PA3 TRACEDATA0	I/O O	I/O port Debug pin	Pull up	-	-
	66	PA4 TRACEDATA1	I/O O	I/O port Debug pin	Pull up	-	-
	67	PA5 TRACEDATA2	I/O O	I/O port Debug pin	Pull up	-	-
	68	PA6 TRACEDATA3	I/O O	I/O port Debug pin	Pull up	-	-
Function	69	PA7	I/O	I/O port	Pull up		
	70	PJ0 INT0	I/O I	I/O port Interrupt request pin	Pull up	○ w/ noise filter	-
PS	71	CVCC	-	Power supply pin	-	-	-
Clock	72	X2	O	Connected to a high-speed oscillator.	-	-	-
PS	73	CVSS	-	GND pin	-	-	-
Clock	74	X1	I	Connected to a high-speed oscillator.	-	○	-
PS	75	REGVSS	-	GND pin	-	-	-
	76	REGVCC	-	Power supply pin	-	-	-
Clock	77	XT1	I	Connected to a low-speed oscillator.	-	○	-
	78	XT2	O	Connected to a low-speed oscillator.	-	-	-
Function	79	PI6 TB4IN0	I/O I	I/O port Inputting the timer B capture trigger	Pull up	○	-
	80	$\overline{\text{NMI}}$	I	Non-maskable interrupt	-	○ w/ noise filter	-
Control	81	MODE	I	Mode pin: Tied to GND pin	-	○	-
Function	82	$\overline{\text{RESET}}$	I	Reset input pin	Tied to Pull up	○ w/ noise filter	-
	83	PI7 TB4IN1	I/O I	I/O port Inputting the timer B capture trigger	Pull up	○	-
	84	PH6 TB3IN0	I/O I	I/O port Inputting the timer B capture trigger	Pull up	○	-
	85	PH7 TB3IN1	I/O I	I/O port Inputting the timer B capture trigger	Pull up	○	-
	86	PJ2 INT2	I/O I	I/O port Interrupt request pin	Pull up	○ w/ noise filter	-
	87	PJ3 INT3	I/O I	I/O port Interrupt request pin	Pull up	○ w/ noise filter	-
	88	PJ4 TB6OUT	I/O O	I/O port Timer B output	Pull up	-	-
	89	PE3 RXIN0	I/O I	I/O port Inputting signal to remote controller	Pull up	○	○
Test	90	TEST4	-	TEST pin: Not connected.	-	-	-

Table2-2 Pin Names and Functions Sorted by Pin (5/5)

Type	# of Pins	Pin Name	Input/Output	Function	Programmable Pull-up/Pull down	Schmitt trigger	Programmable Open Drain Output
Function	91	PC0 AN0	I I	Input port Analog input	Pull up	-	-
	92	PC1 AN1	I I	Input port Analog input	Pull up	-	-
	93	PC2 AN2	I I	Input port Analog input	Pull up	-	-
	94	PC3 AN3	I I	Input port Analog input	Pull up	-	-
	95	PD0 AN4 TB5IN0	I I I	Input port Analog input Inputting the timer B capture trigger	Pull up	-	-
	96	PD1 AN5 TB5IN1	I I I	Input port Analog input Inputting the timer B capture trigger	Pull up	-	-
	97	PD2 AN6 TB6IN0	I I I	Input port Analog input Inputting the timer B capture trigger	Pull up	-	-
	98	PD3 AN7 TB6IN1	I I I	Input port Analog input Inputting the timer B capture trigger of	Pull up	-	-
	99	PD4 AN8	I I	Input port Analog input	Pull up	-	-
	100	PD5 AN9	I I	Input port Analog input	Pull up	-	-

- (Note 1) TEST1 through 4 must be left unconnected.
- (Note 2) Be sure to tie MODE to GND.
- (Note 3) Tie VREFH/ AVCC to power supply and AVSS to GND even if the A/D converter is not used.
- (Note 4) Nch open drain port.
- (Note 5) The noise elimination width of the noise filter is approximately 30 ns under typical conditions.

## 2.2.2 Sorted by Port

Table2-3 Pin Names and Functions Sorted by Port (1/5)

PORT	Type	# of Pins	Pin Name	Input/Output	Function	Programmable Pull-up/Pull down	Schmitt trigger	Programmable Open Drain Output
A	Function / Debug	55	PA0 TMS/SWDIO	I/O I/O	I/O port Debug pin	P-up	○	-
		56	PA1 TCK/SWCLK	I/O I	I/O port Debug pin	P-down	-	-
		64	PA2 TRACECLK	I/O O	I/O port Debug pin	P-up	-	-
		65	PA3 TRACEDATA0	I/O O	I/O port Debug pin	P-up	-	-
		66	PA4 TRACEDATA1	I/O O	I/O port Debug pin	P-up	-	-
		67	PA5 TRACEDATA2	I/O O	I/O port Debug pin	P-up	-	-
		68	PA6 TRACEDATA3	I/O O	I/O port Debug pin	P-up	-	-
	Function	69	PA7	I/O	I/O port	P-up		
B	Function / Debug	54	PB0 TDO/SWV	I/O O	I/O port Debug pin	P-up	-	-
		59	PB1 TDI	I/O I	I/O port Debug pin	P-up	-	-
		60	PB2 TRST	I/O I	I/O port Debug pin	P-up	○	-
	Function	29	PB3	I/O	I/O port	P-up	-	-
		37	PB4	I/O	I/O port	P-up	-	-
		41	PB5	I/O	I/O port	P-up	-	-
		43	PB6	I/O	I/O port	P-up	-	-
47	PB7	I/O	I/O port	P-up	-	-		
C	Function	91	PC0 AN0	I I	Input port Analog input	P-up	-	-
		92	PC1 AN1	I I	Input port Analog input	P-up	-	-
		93	PC2 AN2	I I	Input port Analog input	P-up	-	-
		94	PC3 AN3	I I	Input port Analog input	P-up	-	-
D	Function	95	PD0 AN4 TB5IN0	I I I	Input port Analog input Inputting the timer B capture trigger	P-up	-	-
		96	PD1 AN5 TB5IN1	I I I	Input port Analog input Inputting the timer B capture trigger	P-up	-	-
		97	PD2 AN6 TB6IN0	I I I	Input port Analog input Inputting the timer B capture trigger	P-up	-	-

Table2-3 Pin Names and Functions Sorted by Port (2/5)

PORT	Type	# of Pins	Pin Name	Input/Output	Function	Programmable Pull-up/Pull down	Schmitt trigger	Programmable Open Drain Output
D	Function	98	PD3 AN7 TB6IN1	I I I	Input port Analog input Inputting the timer B capture trigger	P-up	-	-
		99	PD4 AN8	I I	Input port Analog input	P-up	-	-
		100	PD5 AN9	I I	Input port Analog input	P-up	-	-
		1	PD6 AN10	I I	Input port Analog input	P-up	-	-
		2	PD7 AN11	I I	Input port Analog input	P-up	-	-
E	Function	20	PE0 TXD0	I/O O	I/O port Sending serial data	P-up	-	○
		21	PE1 RXD0	I/O I	I/O port Receiving serial data	P-up	○	○
		22	PE2 SCLK0 CTS0	I/O I/O I	I/O port Serial clock input/ output Handshake input pin	P-up	○	○
		89	PE3 RXIN0	I/O I	I/O port Inputting signal to remote controller	P-up	○	○
		23	PE4 TXD1	I/O O	I/O port Sending serial data	P-up	-	○
		24	PE5 RXD1	I/O I	I/O port Receiving serial data	P-up	○	○
		25	PE6 SCLK1 CTS1	I/O I/O I	I/O port Serial clock input/ output Handshake input pin	P-up	○	○
F	Function	33	PF0 TXD2	I/O O	I/O port Sending serial data	P-up	-	○
		34	PF1 RXD2	I/O I	I/O port Receiving serial data	P-up	○	○
		35	PF2 SCLK2 CTS2	I/O I/O I	I/O port Serial clock input/ output Handshake input pin	P-up	○	○
		61	PF3 RXIN1	I/O I	I/O port Inputting signal to remote controller	P-up	○	○
		44	PF4 SDA1/ SO1	I/O I/O O	I/O port If the serial bus interface operates -in the I2C mode : data pin -in the SIO mode: data pin	P-up	○	○
		45	PF5 SCL1/ SI1	I/O I/O I	I/O port If the serial bus interface operates -in the I2C mode : clock pin -in the SIO mode: data pin	P-up	○	○
		46	PF6 SCK1	I/O I/O	I/O port Inputting and outputting a clock if the serial bus interface operates in the SIO mode.	P-up	○	○
		19	PF7 INT5	I/O I	I/O port Interrupt request pin	P-up	○ w/ noise filter	○

Table2-3 Pin Names and Functions Sorted by Port (3/5)

PORT	Type	# of Pins	Pin Name	Input/Output	Function	Programmable Pull-up/Pull down	Schmitt trigger	Programmable Open Drain Output
G	Function	26	PG0 SDA0/ SO0	I/O I/O O	I/O port If the serial bus interface operates -in the I2C mode : data pin -in the SIO mode: data pin	P-up	○	○
		27	PG1 SCL0/ SI0	I/O I/O I	I/O port If the serial bus interface operates -in the I2C mode : clock pin -in the SIO mode: data pin	P-up	○	○
		28	PG2 SCK0	I/O I/O	I/O port Inputting and outputting a clock if the serial bus interface operates in the SIO mode.	P-up	○	○
		6	PG3 INT4	I/O I	I/O port Interrupt request pin	P-up	○ w/ noise filter	○
		15	PG4 SDA2/ SO2	I/O I/O O	I/O port If the serial bus interface operates -in the I2C mode : data pin -in the SIO mode: data pin	P-up	○	○
		16	PG5 SCL2/ SI2	I/O I/O I	I/O port If the serial bus interface operates -in the I2C mode : clock pin -in the SIO mode: data pin	P-up	○	○
		17	PG6 SCK2	I/O I/O	I/O port Inputting and outputting a clock if the serial bus interface operates in the SIO mode.	P-up	○	○
		11	PG7 TB8OUT	I/O O	I/O port Timer B output	P-up	-	○
H	Function/ Control	30	PH0 TB0IN0 BOOT	I/O I I	I/O port Inputting the timer B capture trigger Setting a single boot mode: This pin goes into single boot mode by sampling "L" at the rise of a reset signal.	P-up	○	-
	Function	31	PH1 TB0IN1	I/O I	I/O port Inputting the timer B capture trigger	P-up	○	-
		32	PH2 TB1IN0	I/O I	I/O port Inputting the timer B capture trigger	P-up	○	-
		36	PH3 TB1IN1	I/O I	I/O port Inputting the timer B capture trigger	P-up	○	-
		9	PH4 TB2IN0	I/O I	I/O port Inputting the timer B capture trigger	P-up	○	-
		10	PH5 TB2IN1	I/O I	I/O port Inputting the timer B capture trigger	P-up	○	-
		84	PH6 TB3IN0	I/O I	I/O port Inputting the timer B capture trigger	P-up	○	-
		85	PH7 TB3IN1	I/O I	I/O port Inputting the timer B capture trigger	P-up	○	-

Table2-3 Pin Names and Functions Sorted by Port Number (4/5)

PORT	Type	# of Pins	Pin Name	Input/Output	Function	Programmable Pull-up/Pull down	Schmitt trigger	Programmable Open Drain Output
I	Function	38	PI0 TB0OUT	I/O O	I/O port Timer B output	P-up	-	-
		40	PI1 TB1OUT	I/O O	I/O port Timer B output	P-up	-	-
		42	PI2 TB2OUT	I/O O	I/O port Timer B output	P-up	-	-
		48	PI3 TB3OUT	I/O O	I/O port Timer B output	P-up	-	-
		52	PI4 TB4OUT	I/O O	I/O port Timer B output	P-up	-	-
		53	PI5 TB5OUT	I/O O	I/O port Timer B output	P-up	-	-
		79	PI6 TB4IN0	I/O I	I/O port Inputting the timer B capture trigger	P-up	○	-
		83	PI7 TB4IN1	I/O I	I/O port Inputting the timer B capture trigger	P-up	○	-
J	Function	70	PJ0 INT0	I/O I	I/O port Interrupt request pin	P-up	○ w/ noise filter	-
		49	PJ1 INT1	I/O I	I/O port Interrupt request pin	P-up	○ w/ noise filter	-
		86	PJ2 INT2	I/O I	I/O port Interrupt request pin	P-up	○ w/ noise filter	-
		87	PJ3 INT3	I/O I	I/O port Interrupt request pin	P-up	○ w/ noise filter	-
		88	PJ4 TB6OUT	I/O O	I/O port Timer B output	P-up	-	-
		8	PJ5 TB7OUT	I/O O	I/O port Timer B output	P-up	-	-
		39	PJ6 INT6	I/O I	I/O port Interrupt request pin	P-up	○ w/ noise filter	-
		58	PJ7 INT7	I/O I	I/O port Interrupt request pin	P-up	○ w/ noise filter	-
K	Function	50	PK0 CEC	I/O I/O	I/O port CEC pin	-	○	● (Note 4)
		51	PK1 SCOUT ALARM	I/O O O	I/O port System clock output Alarm output	P-up	-	-
		7	PK2 TB9OUT	I/O O	I/O port Timer B output	P-up	-	-

Table2-3 Pin Names and Functions Sorted by Port (5/5)

Type	# of Pins	Pin Name	Input/Output	Function	Programmable Pull-up/Pull down	Schmitt trigger	Programmable Open Drain Output
Function	82	$\overline{\text{RESET}}$	I	Reset input pin	Tied to Pull up	○ w/ noise filter	-
	80	$\overline{\text{NMI}}$	I	Non-maskable interrupt	-	○ w/ noise filter	-
Control	81	MODE	I	Mode pin: Tied to GND pin	-	○	-
Clock	72	X2	O	Connected to a high-speed oscillator.	-	-	-
	74	X1	I	Connected to a high-speed oscillator.	-	○	-
	77	XT1	I	Connected to a low-speed oscillator.	-	○	-
	78	XT2	O	Connected to a low-speed oscillator.	-	-	-
Test	12	TEST2	-	TEST pin: Not connected.	-	-	-
	18	TEST1	-	TEST pin: Not connected.	-	-	-
	57	TEST3	-	TEST pin: Not connected.	-	-	-
	90	TEST4	-	TEST pin: Not connected.	-	-	-
PS	3	AVSS	I	A/D converter: GND pin (0V) Tie AVSS to power supply even if the A/D converter is not used.	-	-	-
	4	VREFH	I	Supplying the A/D converter with a reference power supply. Tie VREFH to power supply even if the A/D converter is not used.	-	-	-
	5	AVCC	I	Supplying the A/D converter with a power supply. Tie AVCC to power supply even if the A/D converter is not used.	-	-	-
	13	DVSS	-	GND pin	-	-	-
	14	DVCC	-	Power supply pin	-	-	-
	62	DVCC	-	Power supply pin	-	-	-
	63	DVSS	-	GND pin	-	-	-
	71	CVCC	-	Power supply pin	-	-	-
	73	CVSS	-	GND pin	-	-	-
	75	REGVSS	-	GND pin	-	-	-
76	REGVCC	-	Power supply pin	-	-	-	

**(Note 1)** TEST1 through 4 must be left unconnected.

**(Note 2)** Be sure to tie MODE to GND.

**(Note 3)** Tie VREFH/ AVCC to power supply and AVSS to GND even if the A/D converter is not used.

**(Note 4)** Nch open drain port.

**(Note 5)** The noise elimination width of the noise filter is approximately 30 ns under typical conditions.

## 2.3 Pin Names and Power Supply Pins

Table2-4 Pin Names and Power Supplies

Pin name	Power supply
PA	DVCC
PB	DVCC
PC	AVCC
PD	AVCC
PE	DVCC
PF	DVCC
PG	DVCC
PH	DVCC
PI	DVCC
PJ	DVCC
PK	DVCC
X1, X2	CVCC
XT1, XT2	DVCC
$\overline{\text{RESET}}$	DVCC
$\overline{\text{NMI}}$	DVCC
MODE	DVCC

## 2.4 Pin Numbers and Power Supply Pins

Table2-5 Pin Numbers and Power Supplies

Power supply	Pin number	Voltage range
DVCC	14, 62	2.7V~3.6V
AVCC	5	
REGVCC	76	
CVCC	71	

## 3 Processor Core and Memory Map

### 3.1 Processor Core

The TX03 series has a high-performance 32-bit processor core (the ARM Cortex-M3 processor core). For information on the operations of this processor core, please refer to the “Cortex-M3 Technical Reference Manual” issued by ARM Limited. This chapter describes the functions unique to the TX03 series that are not explained in that document.

The following table shows the revision of the processor core in the TMPM330. For further information on each revision, see the documents issued by ARM Limited.

Product Name	Core Revision
TMPM330	r1p1-00rel0

The Cortex-M3 core has the optional blocks. The optional blocks of the revision r1p1 are ETM™ and MPU. Not MPU but ETM is contained in the TMPM330

### 3.2 Configurable Options

The Cortex-M3 core has optional blocks. The optional blocks of the revision r1p1 are ETM™ and MPU. The following tables shows the configurable options in the TMPM330.

Configurable Options	Implementation
MPU	Not implementable
ETM	Implementable

### 3.3 Exceptions/ Interruptions

Exceptions and interruptions are described in the following section.

#### 3.2.1 Number of Interrupt Inputs

The number of interrupt inputs can optionally be defined from 1 to 240 in the Cortex-M3 core. TMPM330FYWFG has 50 interrupt inputs. The number of interrupt inputs is reflected in <INTLINESNUM[4:0]> bit of NVIC register. In this product, if read <INTLINESNUM[4:0]> bit, "0y00001" is read out.

### 3.2.2 Number of Priority Level Interrupt Bits

The Cortex-M3 core can optionally configure the number of priority level interrupt bits from 3 bits to 8 bits. TMPM330 has three priority level interrupt bits. The number of priority level interrupt bits is used for assigning a priority level in the interrupt priority registers and system handler priority registers.

### 3.2.3 SysTick

The Cortex-M3 core has a SysTick timer which can generate SysTick exception. For the detail of SysTick exception, refer to the section of "SysTick" in the exception and the register of SysTick in the NVIC register.

### 3.2.4 SYSRESETREQ

The Cortex-M3 core outputs SYSRESETREQ signal when <SYSRESETREQ> bit of Application Interrupt and Reset Control Register are set. TMPM330 provides the same operation when SYSRESETREQ signal are output.

Note: Do not reset with <SYSRESETREQ> in SLOW mode.

### 3.2.5 LOCKUP

When irreparable exception generates, the Cortex-M3 core outputs LOCKUP signal to show a serious error included in software.

TMPM330 does not use this signal. To return from LOCKUP status, it is necessary to use non-maskable interrupt (NMI) or reset.

### 3.2.6 Auxiliary Fault Status register

The Cortex-M3 core provides auxiliary fault status registers to supply additional system fault information to software.

However, TMPM330 is not defined this function. If auxiliary fault status register is read, always "0x0000\_0000" is read out.

## 3.4 Events

The Cortex-M3 core has event output signals and event input signals. An event output signal is output by SEV instruction execution. If an event is input, the core returns from low-power consumption mode caused by WFE instruction. TMPM330 does not use event output signals and event input signals. Please do not use SEV instruction and WFE instruction.

### 3.5 Power Management

The Cortex-M3 core provides power management system which uses SLEEPING signals and SLEEPDEEP signals. SLEEPDEEP signals are output when <SLEEPDEEP> bit of System Control Register is set. These signals are output in the following circumstances:

- Wait-For-Interrupt (WFI) instruction execution
- Wait-For-Event (WFE) instruction execution
- the timing when interrupt-service-routine (ISR) exit in case that <SLEEPONEXIT> bit of System Control Register is set.

TMPM330 does not use SLEEPDEEP signals so that <SLEEPDEEP> bit must not be set.

And also event signals are not used so that please do not use WFE instruction.

For detail of power management, refer to the Chapter "Clock/Mode control."

### 3.6 Exclusive access

In Cortex-M3 core, the DCode bus system supports exclusive access. However TMPM330 does not use this function.

## 4 Debug Interface

### 4.1 Specification Overview

The TMPM330 contains the Serial Wire JTAG Debug Port (SWJ-DP) unit for interfacing with the In-Circuit Emulator (ICE) and the Embedded Trace Macrocell™ (ETM) unit for instruction trace output. Trace data is output to the dedicated pins (TRACEDATA[0]-[3], SWV) via the on-chip Trace Port Interface Unit (TPIU).

For details about SWJ-DP, ETM and TPIU, refer to “Cortex-M3 Technical Reference Manual” .

### 4.2 Features of SWJ-DP

SWJ-DP supports the two-pin Serial Wire Debug Port (SWDCK, SWDIO) and the JTAG Debug Port (TDI, TDO, TMS, TCK, TRST).

### 4.3 Features of ETM

ETM supports four data signal pins (TRACEDATA[0]-[3]), one clock signal pin (TRACECLK) and trace output from SWV.

### 4.4 Pin Functions

The debug interface pins can also be used as general-purpose ports.

The PA0 and PA1 pins are shared between the JTAG debug port function and the serial wire debug port function. The PB0 pin is shared between the JTAG debug port function and the SWV trace output function.

After reset, the PA0, PA1, PB0, PB1 and PB2 pins are configured as debug port function pins. The functions of other debug interface pins need to be programmed as required.

When using a low power consumption mode, take note of the following points.

- (Note 1)** If PA0 and PB0 are configured as TMS/SWDIO and TDO/SWV, output continues to be enabled even in STOP mode regardless of the setting of the CGSTBYCR<DRVE> bit .
- (Note 2)** If PA1 is configured as a debug function pin, it prevents a low power consumption mode from being fully effective. Configure PA1 to function as a general-purpose port if the debug function is not used.

The table below summarizes the debug interface pin functions and related port settings after reset.

Pin Number	Port (Bit Name)	Debug Function	Port Settings after Reset				
			Function (PxFR)	Input (PxIE)	Output (PxCR)	Pull-up (PxPUP)	Pull-down (PxPDN)
55	PA0	TMS/SWDIO	○	○	○	○	-
56	PA1	TCK/SWCLK	○	○	×	-	○
54	PB0	TDO/SWV	○	×	○	×	-
59	PB1	TDI	○	○	×	○	-
60	PB2	TRST	○	○	×	○	-
64	PA2	TRCECLK	×	×	×	×	-
65	PA3	TRACEDATA0	×	×	×	×	-
66	PA4	TRACEDATA1	×	×	×	×	-
67	PA5	TRACEDATA2	×	×	×	×	-
68	PA6	TRACEDATA3	×	×	×	×	-

○: Enabled    ×: Disabled

#### 4.5 Connection with a Debug Tool

For how to connect a debug tool, refer to the method recommended by each manufacturer.

## 5 Memory Map

The memory maps for the TMPM330FYWFG is based on the ARM Cortex-M3 processor core memory map. The internal ROM, internal RAM and internal I/O of the TMPM330FYWFG is mapped to the code, SRAM and peripheral regions of the Cortex-M3 respectively. The SRAM and internal I/O regions are all included in the bit-band region.

The CPU register region is the processor core's internal register region.

For more information on each region, see the "Cortex-M3 Technical Reference Manual".

Note that access to regions indicated as "Fault" causes a memory fault if memory faults are enabled or a hard fault if memory faults are disabled. Do not access the vendor-specific region.

### 5.1 Memory Map of the TMPM330FYWFG



Fig 5-1 Memory Map

**Note:**In addition to 256KB flash area, the TMPM330FYWFG provides 128-word data/ password area (1 page) for Show Product Information command in the address range 0x0007\_FE00 - 0x0007\_FFFF. See the Chapter "Flash Memory Operation" for details on the single boot mode. Do not Access to the range from 0x0004\_0000 through the password area.

## 6 Reset

The TMPM330 has three reset sources: an external reset pin, WDT and SYSRESETREQ. For reset from the WDT, refer to the chapter on the WDT. For reset from SYSRESETREQ, refer to “Cortex-M3 Technical Reference Manual”.

**Note :** Do not reset with <SYSRESETREQ> in SLOW mode.

### 6.1 Cold Reset

The power-on sequence must include the time for the internal regulator and oscillator to be stable. In the TMPM330, the internal regulator requires at least 700 μs to be stable. The time required to achieve stable oscillation varies with system. At cold reset, the external reset pin must be kept low for a duration of time sufficiently long enough for the internal regulator and oscillator to be stable.

Fig. 6-1 shows the power-on sequence.

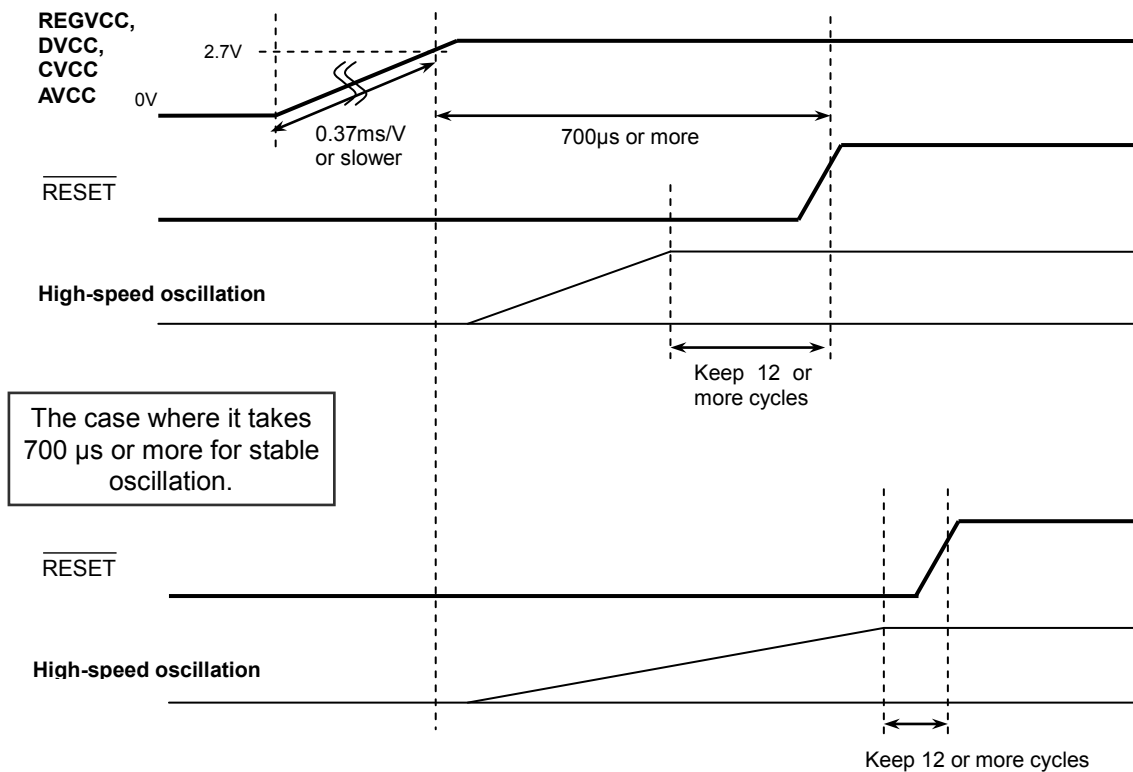

Fig. 6-1 Cold Reset Sequence

- (Note 1) The power supply must be raised (from 0V to 2.7V) at a speed of 0.37ms/V or slower.
- (Note 2) Turn on the power while the  $\overline{\text{RESET}}$  pin is fixed to “L”. Release the  $\overline{\text{RESET}}$  pin while all the power supplies are stabilized within operating voltage.

## 6.2 Warm Reset

### 6.2.1 Reset Period

As a precondition, ensure that the power supply voltage is within the operating range and the internal high-frequency oscillator is providing stable oscillation. To reset the TMPM330, assert the *RESET* signal (active low) for a minimum duration of 12 system clocks.

## 6.3 After Reset

A warm reset initializes the majority of the Cortex-M3 processor core's system control registers and internal I/O registers. Registers that are only initialized by a cold reset are registers related to the processor core's system debug components (FPB, DWT, ITM), the clock generator's reset flag and the Flash security bit.

After reset, the PLL multiplication circuit is inactive and must be enabled in the PLLSEL register if needed.

When the reset exception handling is completed, the program branches to the reset interrupt service routine.

<b>(Note 1) The reset operation may alter the internal RAM state.</b>
---

## 7 Clock/Mode Control

### 7.1 Features

The clock/mode control block enables to select clock gear, prescaler clock and warm-up of the PLL (including clock multiplication circuit) and oscillator.

The low power consumption mode can reduce power consumption.

This chapter describes how to control clocks, clock operating modes and mode transitions.

The clock/mode control block has the following functions:

- Controls the system clock.
- Controls the prescaler clock.
- Controls the PLL multiplication circuit.
- Controls the warm-up timer.

In addition to NORMAL mode, the TMPM330 can operate in three types of low power mode to reduce power consumption according to its usage conditions.

## 7.2 Registers

### 7.2.1 Register List

Table 7-1 shows registers and addresses of the clock generator.

Table 7-1 Registers of Clock Generator

Register name		Address
System control register	CGSYSCR	0x4004_0200
Oscillation control register	CGOSCCR	0x4004_0204
Standby control register	CGSTBYCR	0x4004_0208
PLL selection register	CGPLLSEL	0x4004_020C
System clock selection register	CGCKSEL	0x4004_0210

## 7.2.2 Detailed Description of Registers

### 7.2.2.1 System Control Register

CGSYSR		<b>7</b>	<b>6</b>	<b>5</b>	<b>4</b>	<b>3</b>	<b>2</b>	<b>1</b>	<b>0</b>
	Bit symbol	-	-	-	-	-	GEAR2	GEAR1	GEAR0
	Read/Write	R					R/W	R/W	R/W
	After reset	0	0	0	0	0	0	0	0
	Function	"0" is read.					High-speed clock (fc) gear 000: fc                   100: fc/2 001: reserved           101: fc/4 010: reserved           110: fc/8 011: reserved           111: reserved		
		<b>15</b>	<b>14</b>	<b>13</b>	<b>12</b>	<b>11</b>	<b>10</b>	<b>9</b>	<b>8</b>
	Bit symbol	-	-	-	FPSEL	-	PRCK2	PRCK1	PRCK0
	Read/Write	R			R/W	R	R/W	R/W	R/W
	After reset	0	0	0	0	0	0	0	0
	Function	"0" is read.			fperiph 0:fgear 1:fc	"0" is read.	Prescaler clock 000: fperiph           100: fperiph/16 001: fperiph/2       101: fperiph/32 010: fperiph/4       110: Reserved 011: fperiph/8       111: Reserved		
		<b>23</b>	<b>22</b>	<b>21</b>	<b>20</b>	<b>19</b>	<b>18</b>	<b>17</b>	<b>16</b>
	Bit symbol	-	-	-	-	-	--	SCOSEL1	SCOSEL0
Read/Write	R						R/W	R/W	
After reset	0	0	0	0	0	0	0	1	
Function	"0" is read.						SCOUT output 00: fs 01: fsys/2 10: fsys 11: φT0		
	<b>31</b>	<b>30</b>	<b>29</b>	<b>28</b>	<b>27</b>	<b>26</b>	<b>25</b>	<b>24</b>	
Bit symbol	-	-	-	-	-	-	-	-	
Read/Write	R								
After reset	0	0	0	0	0	0	0	0	
Function	"0" is read.								

<Bit 2:0><GEAR [2:0]> : Specifies the high-speed clock (fc) gear.

<Bit 10:8><PRCK [2:0]> : Specifies the prescaler clock to peripheral I/O.

<Bit 12><FPSEL> : Specifies the source clock to fperiph.

<Bit 17:16><SCOSEL[1:0]> : Enables to output the specified clock from SCOUT pin.

## 7.2.2.2 Oscillation Control Register

	<b>7</b>	<b>6</b>	<b>5</b>	<b>4</b>	<b>3</b>	<b>2</b>	<b>1</b>	<b>0</b>	
CGOSCCR	Bit symbol	-	WUPT2	WUPT1	WUPT0	WUPSEL	PLLON	WUEF	WUEON
	Read/Write	R	R/W	R/W	R/W	R/W	R/W	R	W
	After reset	0	0	0	1	0	0	0	0
	Function	"0" is read.	Selection of warm-up time X1 XT1 000: No warm-up 000:No warm-up 001:2 <sup>10</sup> /input freq. 001:2 <sup>6</sup> / input freq. 010:2 <sup>11</sup> / input freq. 010:2 <sup>7</sup> / input freq. 011:2 <sup>12</sup> / input freq. 011:2 <sup>9</sup> / input freq. 100:2 <sup>13</sup> / input freq. 100:2 <sup>15</sup> / input freq. 101:2 <sup>14</sup> / input freq. 101:2 <sup>16</sup> / input freq. 110:2 <sup>15</sup> / input freq. 110:2 <sup>17</sup> / input freq. 111:2 <sup>16</sup> / input freq. 111:2 <sup>18</sup> / input freq.		Warm-up counter 0: X1 1: XT1	PLL operation 0: Stop (Note)	Status of Warm-up timer (WUP) 0: warm-up completed 1: Warm-up in operation	Operation of warm-up timer (WUP) 0: don't care 1: starting warm-up  "0" is read.	
		<b>15</b>	<b>14</b>	<b>13</b>	<b>12</b>	<b>11</b>	<b>10</b>	<b>9</b>	<b>8</b>
	Bit symbol	-	-	-	-	-	-	XTEN	XEN
	Read/Write	R		R/W		R		R/W	R/W
	After reset	0	0	0	0	0	0	1	1
	Function	"0" is read.		Write "0".		"0" is read.		Low-speed oscillator 0: Stop 1: Oscillation	High-speed oscillator 0: Stop 1: Oscillation
		<b>23</b>	<b>22</b>	<b>21</b>	<b>20</b>	<b>19</b>	<b>18</b>	<b>17</b>	<b>16</b>
	Bit symbol	-	-	-	-	-	-	-	-
	Read/Write	R							
	After reset	0	0	0	0	0	0	0	0
	Function	"0" is read.							
		<b>31</b>	<b>30</b>	<b>29</b>	<b>28</b>	<b>27</b>	<b>26</b>	<b>25</b>	<b>24</b>
	Bit symbol	-	-	-	-	-	-	-	-
	Read/Write	R							
	After reset	0	0	0	0	0	0	0	0
	Function	"0" is read.							

<Bit 0><WUEON> : Enables to start the warm-up timer.

<Bit 1><WUEF> : Enables to monitor the status of the warm-up timer.

<Bit 2><PLLON> : Specifies operation of the PLL.  
It stops after reset. Setting the bit is required.

Note: Firstly set "0" to CGPLLSEL<PLLSEL>. Secondly read CGPLLSEL<PLLSEL> to check the setting in which multiplication clock is not used (CGPLLSEL<PLLSEL>="0"). Thirdly, set "0" to <PLLON>.

<Bit 3><WUPSEL> : Specifies the oscillator to warm-up. A clock generated by the specified oscillator is used for the warm-up timer count.

<Bit 6:4><WUPT[2:0]> : Specifies time of the warm-up timer.

<Bit 8><XEN> : Specifies operation of the high-speed oscillator.

<Bit 9><XTEN> : Specifies operation of the low-speed oscillator.

## 7.2.2.3 Standby Control Register

	<b>7</b>	<b>6</b>	<b>5</b>	<b>4</b>	<b>3</b>	<b>2</b>	<b>1</b>	<b>0</b>	
CGSTBYCR	Bit symbol	-	-	-	-	-	STBY2	STBY1	STBY0
	Read/Write	R					R/W	R/W	R/W
	After reset	0	0	0	0	0	0	1	1
	Function	"0" is read.					Low power consumption mode 000: Reserved 001: STOP 010: SLEEP 011: IDLE 100: Reserved 101: Reserved 110: Reserved 111: Reserved		
	<b>15</b>	<b>14</b>	<b>13</b>	<b>12</b>	<b>11</b>	<b>10</b>	<b>9</b>	<b>8</b>	
	Bit symbol	-	-	-	-	-	RXTEN	RXEN	
	Read/Write	R					R/W	R/W	
	After reset	0	0	0	0	0	0	1	
	Function	"0" is read.					Low-speed oscillator after releasing STOP mode 0: Stop 1: Oscillation	High-speed oscillator after releasing STOP mode 0: Stop 1: Oscillation	
	<b>23</b>	<b>22</b>	<b>21</b>	<b>20</b>	<b>19</b>	<b>18</b>	<b>17</b>	<b>16</b>	
	Bit symbol	-	-	-	-	-	-	DRVE	
	Read/Write	R					R/W	R/W	
	After reset	0	0	0	0	0	0	0	
	Function	"0" is read.					Write "0".	Pin status in STOP mode 0: Active 1: Inactive	
	<b>31</b>	<b>30</b>	<b>29</b>	<b>28</b>	<b>27</b>	<b>26</b>	<b>25</b>	<b>24</b>	
	Bit symbol	-	-	-	-	-	-	-	
	Read/Write	R							
	After reset	0	0	0	0	0	0	0	
	Function	"0" is read.							

<Bit 2:0><STBY[2:0]> : Specifies the low power consumption mode.

<Bit 8><RXEN> : Specifies the high-speed oscillator operation after releasing the STOP mode.

<Bit 9><RXTEN> : Specifies the low-speed oscillator operation after releasing the STOP mode.

<Bit 16><DRVE> : Specifies the pin status in the STOP mode.

## 7.2.2.4 PLL Selection Register

	<b>7</b>	<b>6</b>	<b>5</b>	<b>4</b>	<b>3</b>	<b>2</b>	<b>1</b>	<b>0</b>	
CGPLLSEL	Bit symbol	-	-	-	-	-	-	PLLSEL	
	Read/Write	R							R/W
	After reset	0	0	0	0	0	0	0	
	Function	"0" is read.							Use of PLL 0: Disuse. X1 selected 1: Use
	<b>15</b>	<b>14</b>	<b>13</b>	<b>12</b>	<b>11</b>	<b>10</b>	<b>9</b>	<b>8</b>	
	Bit symbol	-	-	-	-	-	-	-	
	Read/Write	R							
	After reset	0	0	0	0	0	0	0	
	Function	"0" is read.							
	<b>23</b>	<b>22</b>	<b>21</b>	<b>20</b>	<b>19</b>	<b>18</b>	<b>17</b>	<b>16</b>	
	Bit symbol	-	-	-	-	-	-	-	
	Read/Write	R							
	After reset	0	0	0	0	0	0	0	
	Function	"0" is read.							
	<b>31</b>	<b>30</b>	<b>29</b>	<b>28</b>	<b>27</b>	<b>26</b>	<b>25</b>	<b>24</b>	
	Bit symbol	-	-	-	-	-	-	-	
	Read/Write	R							
	After reset	0	0	0	0	0	0	0	
	Function	"0" is read.							

<Bit 0><PLLSEL> : Specifies use or disuse of the clock multiplied by the PLL.

"X1" is automatically set after reset. Resetting is required when using the PLL.

7.2.2.5 System Clock Selection Register

CGCKSEL		<b>7</b>	<b>6</b>	<b>5</b>	<b>4</b>	<b>3</b>	<b>2</b>	<b>1</b>	<b>0</b>
	Bit symbol	-	-	-	-	-	-	SYSCK	SYSCK FLG
	Read/Write	R						R/W	R
	After reset	0	0	0	0	0	0	0	0
	Function	"0" is read.						System clock	System clock status
								0: High-speed (fc)	0: High-speed (fc)
								1: Low-speed (fs)	1: Low-speed (fs)
									Stable oscillation identical with <SYSCK> value.
		<b>15</b>	<b>14</b>	<b>13</b>	<b>12</b>	<b>11</b>	<b>10</b>	<b>9</b>	<b>8</b>
	Bit symbol	-	-	-	-	-	-	-	-
Read/Write	R								
After reset	0	0	0	0	0	0	0	0	
Function	"0" is read.								
	<b>23</b>	<b>22</b>	<b>21</b>	<b>20</b>	<b>19</b>	<b>18</b>	<b>17</b>	<b>16</b>	
Bit symbol	-	-	-	-	-	-	-	-	
Read/Write	R								
After reset	0	0	0	0	0	0	0	0	
Function	"0" is read.								
	<b>31</b>	<b>30</b>	<b>29</b>	<b>28</b>	<b>27</b>	<b>26</b>	<b>25</b>	<b>24</b>	
Bit symbol	-	-	-	-	-	-	-	-	
Read/Write	R								
After reset	0	0	0	0	0	0	0	0	
Function	"0" is read.								

<Bit 0><SYSCKFLG> : Shows the status of the system clock. Switching the oscillator with <SYSCK> generates time lag to complete. If the output of the oscillator specified in <SYSCK> is read out by <SYSCKFLG>, the switching has been completed.

<Bit 1><SYSCK> : Enables to specify the system clock. Setting OSCCR1<XEN> and <XTEN> to "1" in advance is required.

## 7.3 Clock Control

### 7.3.1 Clock Type

Fig.7-1 shows the clock system diagram. Each clock is defined as follows.

fosc	: Clock input from the X1 and X2 pins
fs	: Clock input from the XT1 and XT2 (low-speed clock)
fpll	: Clock quadrupled by PLL
fc	: Clock specified by CGPLLSEL<PLLSEL> (high-speed clock)
fgear	: Clock specified by CGSYSCR<GEAR[2:0]>
fsys	: Clock specified by CGCKSEL<SYSCK> (system clock)
fperiph	: Clock specified by CGSYSCR<FPSEL>
$\Phi T0$	: Clock specified by CGSYSCR<PRCK[2:0]> (prescaler clock)

The high-speed clock fc and the prescaler clock  $\Phi T0$  are dividable.

- High-speed clock: fc, fc/2, fc/4, fc/8
- Prescaler clock: fperiph, fperiph/2, fperiph/4, fperiph/8, fperiph/16, fperiph/32

### 7.3.2 Initial Values after Reset

Reset initializes the clock configuration as follows.

High-speed oscillator	: ON (oscillating)
Low-speed oscillator	: ON (oscillating)
PLL (phase locked loop circuit)	: OFF (stop)
High-speed clock gear	: fc (no frequency dividing)

Reset causes all the clock configurations excluding the low-speed clock (fs) to be the same as fosc.

fc	= fosc
fsys	= fosc
$\Phi T0$	= fosc

For example, reset configures fsys as 10MHz when a 10MHz oscillator is connected to the X1 or X2 pin.

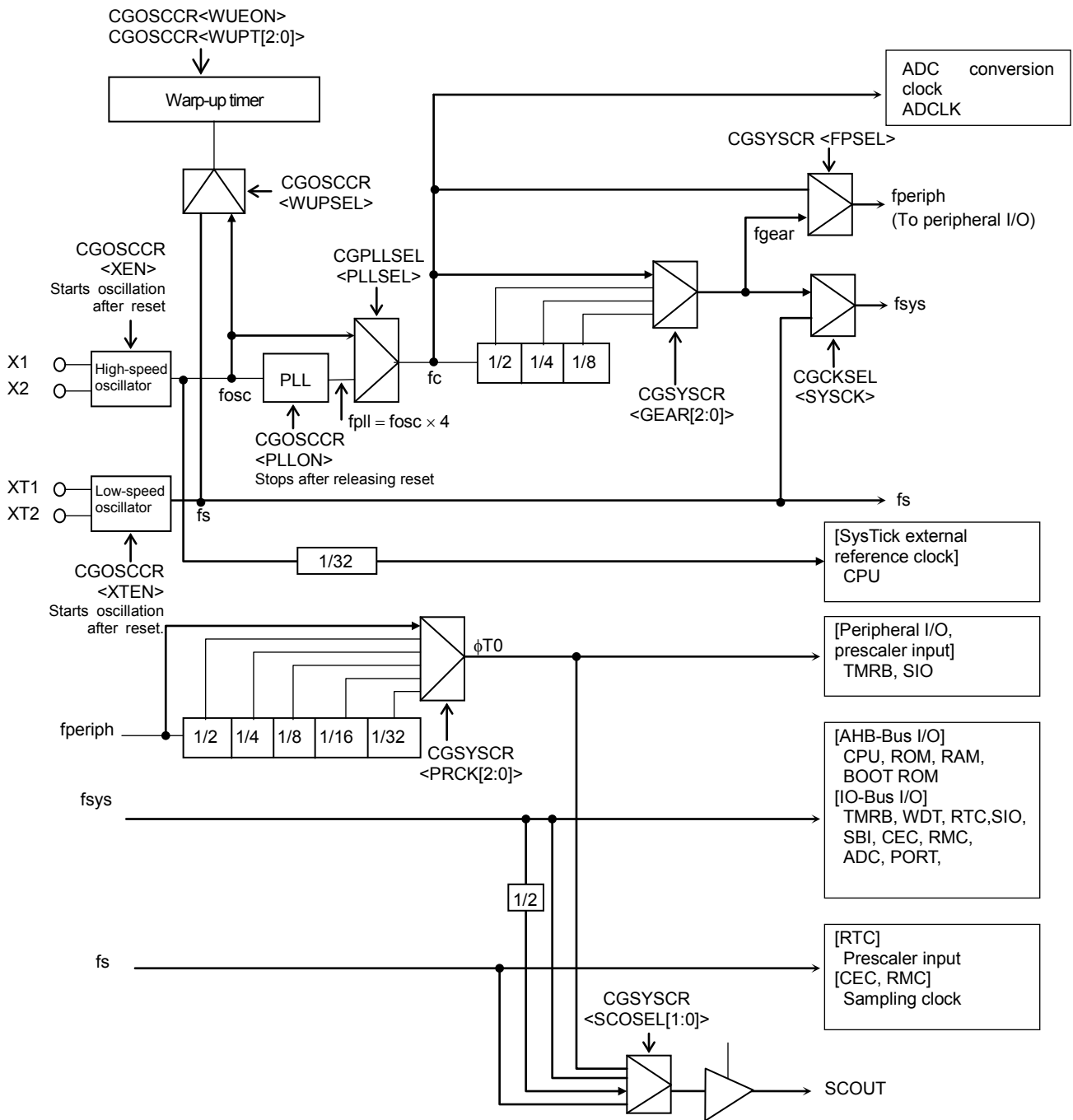

Fig.7-1 Clock Block Diagram

**(Note) The input clocks to selector shown with an arrow are set as default after reset.**

### 7.3.3 Clock Multiplication Circuit (PLL)

This circuit outputs the fpll clock that is quadruple of the high-speed oscillator output clock, fosc. This lowers the oscillator input frequency while increasing the internal clock speed.

The PLL is disabled after reset is released. To enable the PLL, set "1" to the CGOSCCR<WUEF> bit. The PLL requires a certain amount of time to be stabilized, which should be secured using the warm-up function.

**(Note) It takes approx. 200μs for the PLL to be stabilized**

#### 7.3.3.1 Start PLL sequence

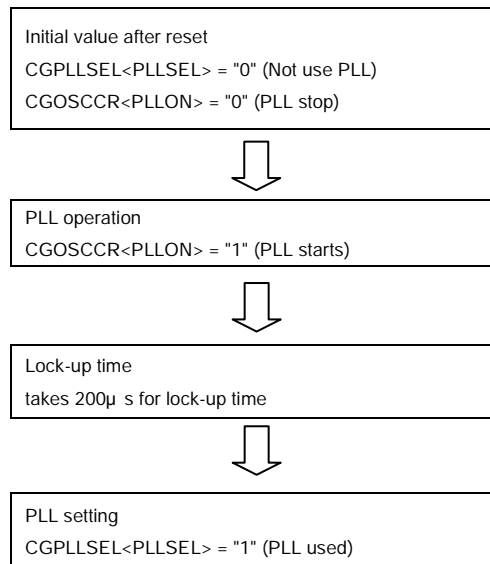

Possible to use the multiplied system clock

### 7.3.4 Warm-up Function

The warm-up function secures the stability time for the oscillator and the PLL with the warm-up timer.

The warm-up function is used when returning from STOP/SLEEP mode. In this case, an interrupt for returning from the low power consumption mode triggers the automatic timer count. After the specified time is reached, the system clock is output and the CPU starts operation.

In STOP/ SLEEP modes, the PLL is disabled. When returning from these modes, configure the warm-up time in consideration of the stability time of the PLL and the internal oscillator.

#### How to configure the warm-up function

Specify the count up clock for the warm-up counter in the CGOSCCR<WUPSEL> bit.

The warm-up time can be selected by setting the CGOSCCR<WUPT[2:0]>. The CGOSCCR<WUEON><WUEF> is used to confirm the start and completion of warm-up through software (instruction). After the completion of warm-up is confirmed, switch the system clock by setting the CGCKSEL<SYSCK>.

When clock switching occurs, the current system clock can be checked by monitoring the CGCKSEL<SYSCKFLG>.

Table 7-2 shows the warm-up time.

Table 7-2 Warm-up Time (fosc=10 MHz, fs=32.768 kHz)

Warm-up time options CGOSCCR<WUPT [2:0]>	High-speed clock (fosc) CGOSCCR<WUPSEL>="0"		Low-speed clock (fs) CGOSCCR<WUPSEL>="1"	
000	—	Without warm-up	—	Without warm-up
001	2 <sup>10</sup> /input frequency	102.4 (μs)	2 <sup>6</sup> /input frequency	1.953 (ms)
010	2 <sup>11</sup> /input frequency	204.8 (μs)	2 <sup>7</sup> /input frequency	3.906 (ms)
011	2 <sup>12</sup> /input frequency	409.6 (μs)	2 <sup>8</sup> /input frequency	7.813 (ms)
100	2 <sup>13</sup> /input frequency	819.2 (μs)	2 <sup>15</sup> /input frequency	1.0 (s)
101	2 <sup>14</sup> /input frequency	1.638 (ms)	2 <sup>16</sup> /input frequency	2.0 (s)
110	2 <sup>15</sup> /input frequency	3.277 (ms)	2 <sup>17</sup> /input frequency	4.0 (s)
111	2 <sup>16</sup> /input frequency	6.554 (ms)	2 <sup>18</sup> /input frequency	8.0 (s)

**(Note)** The warm-up timer operates according to the oscillation clock, and it may contain errors if there is any fluctuation in the oscillation frequency. Therefore, the warm-up time should be taken as approximate time.

The following are the examples of the warm-up function configuration.

<Example 1 Securing the stability time fro the PLL>

CGOSCCR<WUPSEL>="0" : Specify the warm-up counter  
 CGOSCCR<WUPT[2:0]>="010" : Specify the warm-up time (204.8μs)  
 CGOSCCR<WUEON>="1" : Start the warm-up timer (WUP)  
 CGOSCCR<WUEF> Read : Wait until the state becomes "0" (warm-up is finished)

<Example 2> Transition from the NORMAL mode to the SLOW mode

CGOSCCR<WUPSEL>="1": Specify the warm-up counter  
 CGOSCCR<WUPT2[:0]>="xxx" : Specify the warm-up time  
 CGOSCCR<XTEN>="1" : Enable the low-speed oscillation (fs)  
 CGOSCCR<WUEON>="1" : Start the warm-up timer.  
 CGOSCCR<WUEF>Read : Wait until the state becomes "0" (warm-up is finished)  
 CGCKSEL<SYSCK>="1" : Switch the system clock to low speed (fs)  
 CGCKSEL<SYSCKFLG> Read: Confirm that the current state is "1" (the current system clock is fs)  
 CGOSCCR<XEN>="0" : Disable the high-speed oscillation (fosc)

<Example 3> Transition from the SLOW mode to the NORMAL mode

CGOSCCR<WUPSEL>="0": Specify the warm-up counter  
 CGOSCCR<WUPT[2:0]>="xxx" : Specify the warm-up time  
 CGOSCCR<XEN>="1" : Enable the high-speed oscillation (fosc)  
 CGOSCCR<WUEON>="1" : Start the warm-up timer.  
 CGOSCCR<WUEF> Read : Wait until the state becomes "0" (warm-up is finished).  
 CGCKSEL<SYSCK>="0" : Switch the system clock to high speed (fgear)  
 CGCKSEL<SYSCKFLG> Read: Confirm that the current state is "0" (the current system clock is fgear)  
 CGOSCCR<XTEN>="0" : Disable the low-speed oscillation (fs)

**(Note)** When switching the system clock, ensure that the switching has been completed by reading the CGSYSCR<SYSCKFLG>.

### 7.3.5 System Clock

The TMPM330 offers two selectable system clocks: low-speed or high-speed. The high-speed clock is dividable.

- Input frequency from X1 and X2: 8MHz~10MHz
- Allows for oscillator connection or external clock input.
- Clock gear: 1/1, 1/2, 1/4, 1/8 (after reset: 1/1)

Table 7-3 Range of High-frequency

Input freq. from X1 and X2	Min. operating freq.	Max. operating freq.	After reset (PLL=OFF, CG=1/1)	Clock gear (CG) @PLL=ON				Clock gear (CG) @PLL=OFF			
				1/1	1/2	1/4	1/8	1/1	1/2	1/4	1/8
8MHz	1MHz	40MHz	8	32	16	8	4	8	4	2	1
10MHz			10	40	20	10	5	10	5	2.5	1.25

\* PLL=ON/OFF setting: available in CGOSCCR<PLLON>  
Clock gear setting: available in CGSYSCR<GEAR[2:0]>

- Input frequency from XT1 and XT2

Table 7-4 Range of Low Frequency

Input Frequency Range	Maximum Operating Frequency	Minimum Operating Frequency
30 ~ 34(kHz)	34 kHz	30 kHz

**(Note 1)** Switching of clock gear is executed when a value is written to the CGSYSCR<GEAR[2:0]> register. The actual switching takes place after a slight delay.

**(Note 2)** The CEC function uses the low-speed clock as a sampling clock. The allowable margin of error when the CEC function is used is approximately  $\pm 4\%$  at 32.768 kHz.

### 7.3.6 Prescaler Clock Control

Each peripheral function (TMRB0-9 and SIO0-2) has a prescaler for dividing a clock. As the clock  $\phi T0$  to be input to each prescaler, the "fperiph" clock specified in the CGSYSCR<FPSEL> can be divided according to the setting in the CGSYSCR<PRCK[2:0]>. After the controller is reset, fperiph/1 is selected as  $\phi T0$ .

**(Note)** To use the clock gear, ensure that you make the time setting such that prescaler output  $\phi Tn$  from each peripheral function is slower than fsys ( $\phi Tn < fsys$ ). Do not switch the clock gear while the timer counter or other peripheral function is operating.

### 7.3.7 System Clock Pin Output Function

The TMPM330 enables to output the system clock from a pin. The PK1/SCOUT pin can output the low speed clock  $f_s$ , the system clock  $f_{sys}$  and  $f_{sys}/2$ , and the prescaler input clock for peripheral I/O  $\phi T0$ . By setting the port K registers, the PKCR<PK1C> and PKFR1<PK1F1> to "1", the PK1/SCOUT pin (pin number 51) becomes the SCOUT output pin. The output clock is selected by setting the CGSYSCR<SCOSEL[1:0]>.

Table 7-5 shows the pin states in each mode when the SCOUT pin is set to the SCOUT output.

Table 7-5 Scout Output State in Each Mode

SCOUT selection CGSYSCR	Mode	NORMAL	SLOW	Low power consumption mode		
				IDLE	SLEEP	STOP
<SCOSEL[1:0]> = "00"		Output the $f_s$ clock.				
<SCOSEL[1:0]> = "01"		Output the $f_{sys}/2$ clock.				
<SCOSEL[1:0]> = "10"		Output the $f_{sys}$ clock.				
<SCOSEL[1:0]> = "11"		Output the $\phi T0$ clock.				Fixed to "0" or "1".

**(Note1)** The phase difference (AC timing) between the system clock output by the SCOUT and the internal clock is not guaranteed.

**(Note2)** When  $f_{sys}$  is output from SCOUT pin, SCOUT pin outputs the unexpected waveform just after changing clock gear. In the case of influencing to system by the unexpected waveform, the output of SCOUT pin should be disabled when changing the clock gear.

## 7.4 Modes and Mode Transitions

### 7.4.1 Mode Transitions

The NORMAL mode and the SLOW mode use the high-speed and low-speed clocks for system clock respectively.

The IDLE, SLEEP and STOP modes can be used as the low power consumption mode that enables to reduce power consumption by halting processor core operation.

When the low-speed clock is not used, the SLOW and SLEEP modes cannot be used.

Fig.7-2 shows a mode transition diagram

For a description of sleep-on-exit, refer to “Cortex-M3 Technical Reference Manual”.

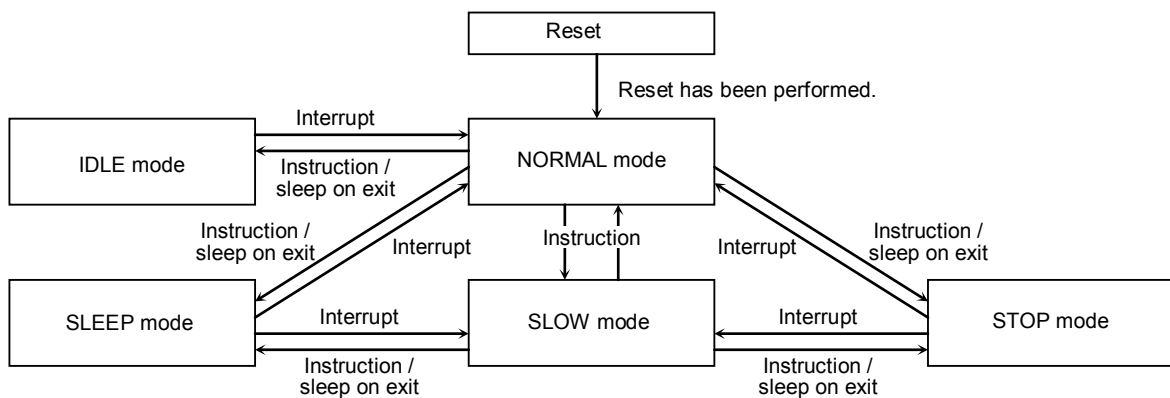

Fig.7-2 Mode Transition Diagram

Note: The warm-up is needed. The warm-up time must be set in NORMAL modes before changing to STOP, SLEEP modes. Regarding warm-up time, refer to "6.3.4 Warm-up function".

## 7.5 Operation Modes

Two operation modes, NORMAL and SLOW, are available. The features of each mode are described below.

### 7.5.1 NORMAL Mode

This mode is to operate the CPU core and the peripheral hardware by using the high-speed clock. It is shifted to the NORMAL mode after reset. The low-speed clock can also be used.

### 7.5.2 SLOW Mode

This mode is to operate the CPU core and the peripheral hardware by using the low-speed clock with high-speed clock stopped.

The SLOW mode reduces power consumption compared to the NORMAL mode.

This mode allows only the following peripheral functions to operate: I/O ports, real-time clock (RTC), CEC and remote control signal preprocessor (RMC).

**(Note1) Be sure to stop peripheral functions except for the CPU, RTC, I/O ports, CEC and RMC before switching to the SLOW mode.**

**(Note2) In the SLOW mode, be sure not to perform reset using the application interrupt and Reset Control Register<SYSRESETREG> of the Cortex-M3 NVIC register.**

## 7.6 Low Power Consumption Modes

The TMPM330 has three low power consumption modes: IDLE, SLEEP and STOP. To shift to the low power consumption mode, specify the mode in the system control register CGSTBYCR<STBY[2:0]> and execute the WFI (Wait For Interrupt) instruction. In this case, execute reset or generate the interrupt to release the mode. Releasing by the interrupt requires settings in advance. See chapter 6 for details.

**(Note 1) Transition to the low power consumption mode by executing the WFE (Wait For Event) instruction is prohibited as the TMPM330 does not offer any event for releasing the low power consumption mode.**

**(Note 2) The TMPM330 does not support the low power consumption mode configured with the SLEEPDEEP bit in the Cortex-M3 core. Setting the SLEEPDEEP bit of the system control register is prohibited.**

The features of each mode are described as follows.

### 7.6.1 IDLE Mode

Only the CPU is stopped in this mode.

Each peripheral function has one bit in its control register for enabling or disabling operation in the IDLE mode. When the IDLE mode is entered, peripheral functions for which operation in the IDLE mode is disabled stop operation and hold the state at that time.

The following peripheral functions can be enabled or disabled in the IDLE mode. For setting details, see the chapter on each peripheral function.

- 16-bit timer/event counter (TMRB)
- Serial channel (SIO)
- Serial bus interface (SBI)
- AD converter (ADC)
- Watchdog timer (WDT)

### 7.6.2 SLEEP Mode

The internal low-speed oscillator, real time clock, CEC and RMC operate. By releasing the SLEEP mode, the device returns to the preceding mode of the SLEEP mode and starts operation.

**(Note)** When PA1 (pin number 56) is configured as a debug function pin, it prevents the low power consumption mode from being fully effective. Configure PA1 to function as a general-purpose port if the debug function is not used.

### 7.6.3 STOP Mode

All the internal circuits including the internal oscillator are brought to a stop.

By releasing the STOP mode, the device returns to the preceding mode of the STOP mode and starts operation.

The STOP mode enables to select the pin status by setting the CGSTBYCR<DRVE>. Table 7-6 shows the pin status in the STOP mode.

**(Note)** When PA1 (pin number 56) is configured as a debug function pin, it prevents the low power consumption mode from being fully effective. Configure PA1 to function as a general-purpose port when the debug function is not used.

Table 7-6 Pin States in STOP Mode

	Pin Name	I/O	<DRVE>=0	<DRVE>=1
Not Ports	X1, XT1	Input only	×	×
	X2, XT2	Output only	"H" level output	"H" level output
	RESET, NMI, MODE	Input only	○	○
Ports	PA0, PB0 [When used as a debug pin (PxFR<n>=1) and output is enabled (PxCR<n>=1)]	Input	×	Depends on PxIE<n>.
		Output	Enabled when data is valid. Disabled when data is invalid.	Enabled when data is valid. Disabled when data is invalid.
	PF7, PG3, PJ0-3, PJ6, PJ7 [When used as an interrupt pin (PxFR<n>=1) and input is enabled (PxIE<n>=1)]	Input	○	○
		Output	×	Depends on PxCR<n>.
	Other port pins	Input	×	Depends on PxIE<n>.
		Output	×	Depends on PxCR<n>.

○ : Input or output enabled

× : Input or output disabled.

### 7.6.4 Low power Consumption Mode Setting

The low power consumption mode is specified by the setting of the standby control register CGSTBYCR<STBY[2:0]>.

Table 7-7 shows the mode setting in the <STBY[2:0]>.

Table 7-7 Low power consumption mode setting

Mode	CGSTBYCR <STBY[2:0]>
STOP	001
SLEEP	010
IDLE	011

**(Note)** Do not set any value other than those shown above in <STBY2:0>.

### 7.6.5 Operational State in Each Mode

Table 7-8 show the operational state in each mode.

For I/O port, “o” and “x” indicate that input/output is enabled and disabled respectively. For other functions, “o” and “x” indicate that clock is supplied and is not supplied respectively.

Table 7-8 Operational State in Each Mode

Block	NORMAL	SLOW	IDLE	SLEEP	STOP
Processor core	o	o	x	x	x
I/O port	o	o	o	o	* (Note 3)
ADC	o	x (Note 1)	ON/OFF selectable for each module	x	x
SIO	o	x (Note 1)		x	x
SBI	o	x (Note 1)		x	x
TMRB	o	x (Note 1)		x	x
WDT	o	x (Note 1)		x	x
CEC	o	o	o	o	x
RMC	o	o	o	o	x
RTC	o	o	o	o	x
CG	o	o	o	o	x
PLL	o	x	o	x	x
High-speed oscillator (fc)	o	*(Note 2)	o	x	x
Low-speed oscillator (fs)	o	o	o	o	x

o: Operating, x: Stopped

**(Note 1)** In the SLOW mode, the ADC, SIO, SBI, TMRB and WDT cannot be used and must be stopped.

**(Note 2)** The high-speed oscillator does not stop automatically and must be stopped by setting the CGOSCCR<XEN> bit.

**(Note 3)** The state depends on the CGSTBYCR<DRVE> bit.

## 7.6.6 Releasing the Low Power Consumption Mode

The low power consumption mode can be released by an interrupt request, NMI or reset. The release source that can be used is determined by the low power consumption mode selected. Details are shown in Table 7-9.

Table 7-9 Release Source in Each Mode

Low power consumption mode		IDLE	SLEEP	STOP	
Release source	Interrupt	INT0~7 (Note 1)	○	○	○
		INTRTC	○	○	×
		INTTB0~9	○	×	×
		INTCAP00~60, 01~61	○	×	×
		INTRX0~2, INTTX0~2	○	×	×
		INTSBI0~2	○	×	×
		INTCECRX, INTCECTX	○	○	×
		INTRMCRX0,1	○	○	×
		INTAD/INTADHP/ INTADM0,1	○	×	×
	SysTick interrupt	○	×	×	
NMI (INTWDT)	○	×	×		
NMI (INT pin)	○	○	○		
RESET (RESET pin)	○	○	○		

○: Starts the interrupt handling after the mode is released. (The reset initializes the LSI).

×: Unavailable

**(Note 1)** To release the low power consumption mode by using the level mode interrupt, keep the level until the interrupt handling is started. Changing the level before then will prevent the interrupt handling from starting properly.

**(Note 2)** For shifting to the low power consumption mode, set the CPU to prohibit all the interrupts other than the release source. If not, releasing may be executed by an unspecified interrupt.

- Release by interrupt request

To release the low power consumption mode by an interrupt, the CPU must be set in advance to detect the interrupt. In addition to the setting in the CPU, the clock generator must be set to detect the interrupt to be used to release the SLEEP and STOP modes.

- Release by NMI

There are two kinds of NMI sources: WDT interrupt (INTWDT) and NMI pin. INTWDT can only be used in the IDLE mode. The NMI pin can be used to release all the lower power consumption modes.

- Release by reset

Any low power consumption modes can be released by reset from the RESET pin. After that, the mode switches to NORMAL and all the registers are initialized as is the case with normal reset.

Note that returning to NORMAL mode by reset does not induce the automatic warm-up. Keep the reset signal valid until the oscillator operation becomes stable.

Refer to "Interrupts" for details.

- Release by SysTick interrupt

SysTick interrupt can only be used in the IDLE mode.

### 7.6.7 Warm-up

Mode transition may require the warm-up so that the internal oscillator provides stable oscillation.

In the mode transition from STOP to NORMAL/ SLOW or from SLEEP to NORMAL, the warm-up counter is activated automatically. And then the system clock output is started after the elapse of configured warm-up time. It is necessary to select the oscillator to be used for warm-up in the CGOCCR<WUPSEL> and to set the warm-up time in the CGOSCCR<WUPT[2:0]> before executing the instruction to enter the STOP/ SLEEP mode.

**(Note)** In STOP/ SLEEP modes, the PLL is disabled. When returning from these modes, configure the warm-up time in consideration of the stability time of the PLL and the internal oscillator. It takes approx. 200 $\mu$ s for the PLL to be stabilized.

In the transition from NORMAL to SLOW/ SLEEP, the warm-up is required so that the internal oscillator to stabilize if the low-speed clock is disabled. Enable the low-speed clock and then activate the warm-up by software.

In the transition from SLOW to NORMAL when the high-speed clock is disabled, enable the high-speed clock and then activate the warm-up.

Table 7-10 shows whether the warm-up setting of each mode transition is required or not.

Table 7-10 Warm-up setting in mode transition

Mode transition	Warm-up setting
NORMAL→IDLE	Not required
NORMAL→SLEEP	(Note 1)
NORMAL→SLOW	(Note 1)
NORMAL→STOP	Not required
IDLE→NORMAL	Not required
SLEEP→NORMAL	Auto-warm-up
SLEEP→SLOW	Not required
SLOW→NORMAL	(Note 2)
SLOW→SLEEP	Not required
SLOW→STOP	Not required
STOP→NORMAL	Auto-warm-up (Note 3)
STOP→SLOW	Auto-warm-up

**(Note 1)** If the low-speed clock is disabled, enable the low-speed clock and then activate the warm-up by software.

**(Note 2)** If the high-speed clock is disabled, enable the high-speed clock and then activate the warm-up by software.

**(Note 3)** Returning to NORMAL mode by reset does not induce the automatic warm-up. Keep the reset signal valid until the oscillator operation becomes stable.

## 7.6.8 Clock Operations in Mode Transition

The clock operations in mode transition are described in the following sections 7.6.8.1 to 7.6.8.4.

### 7.6.8.1 Transition of operation modes: NORMAL→STOP→NORMAL

When returning to NORMAL mode from STOP mode, the warm-up is activated automatically. It is necessary to set the warm-up time before entering the STOP mode.

Returning to NORMAL mode by reset does not induce the automatic warm-up. Keep the reset signal asserted until the oscillator operation becomes stable.

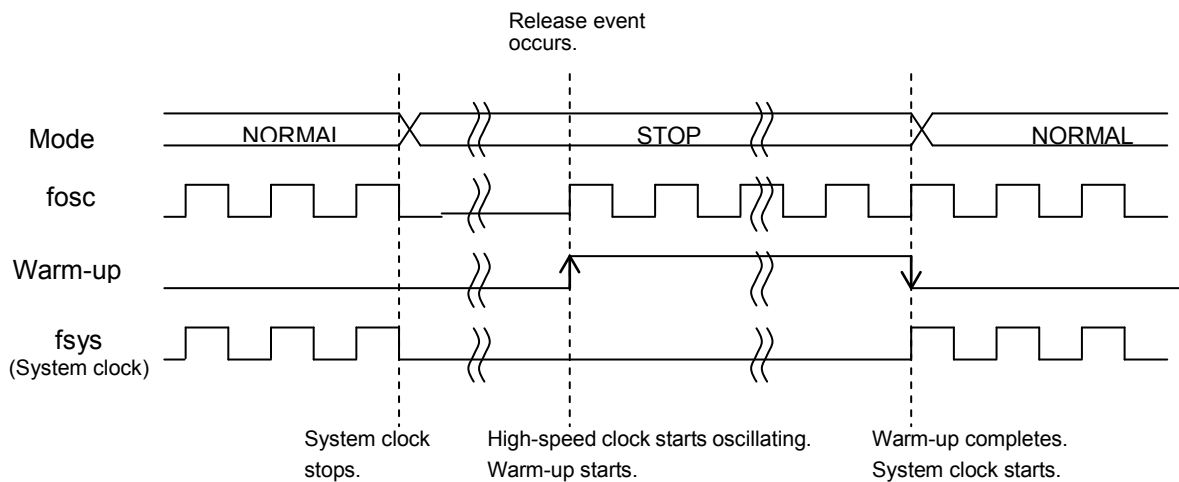

### 7.6.8.2 Transition of operation modes: NORMAL→SLEEP→NORMAL

When returning to NORMAL mode from SLEEP mode, the warm-up is activated automatically. It is necessary to set the warm-up time before entering the SLEEP mode.

Returning to NORMAL mode by reset does not induce the automatic warm-up. Keep the reset signal asserted until the oscillator operation becomes stable.

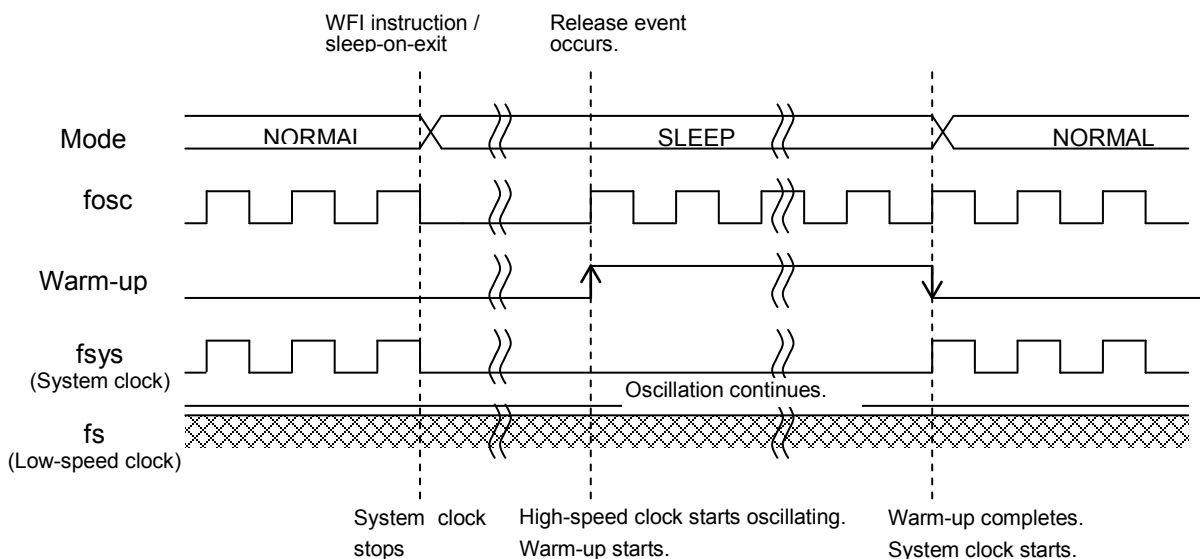

**7.6.8.3 Transition of operation modes: SLOW→STOP→SLOW**

The warm-up is activated automatically. It is necessary to set the warm-up time before entering the STOP mode.

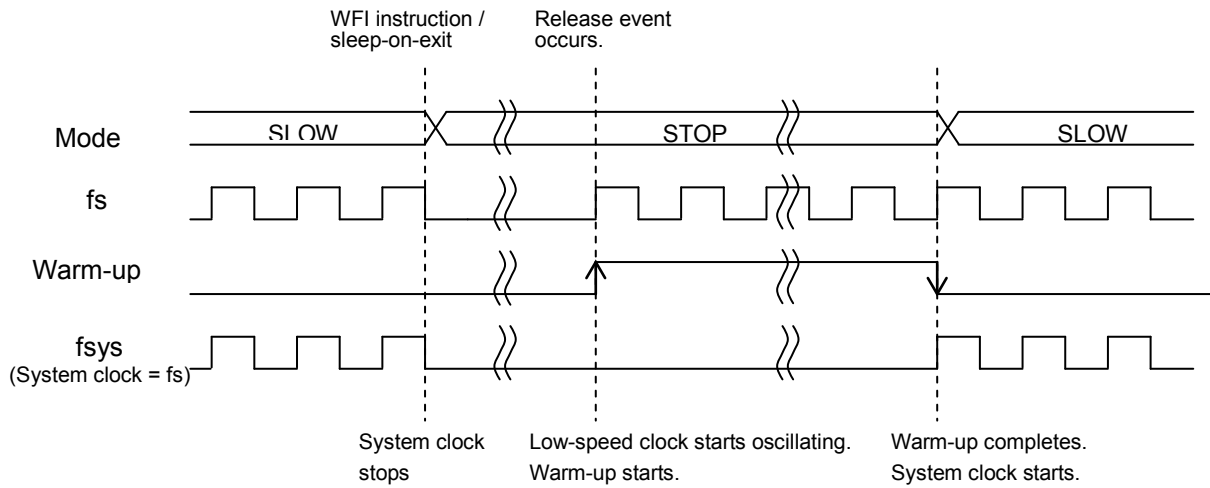

**7.6.8.4 Transition of operation modes: SLOW→SLEEP→SLOW**

The low-speed clock continues oscillation in the SLEEP mode. There is no need to make a warm-up setting.

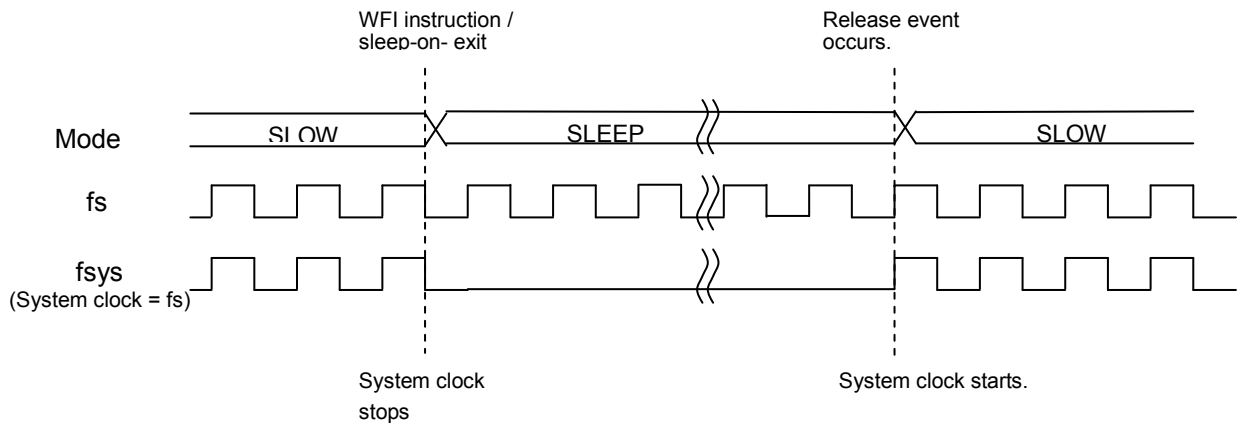

## 8 Exceptions

This chapter describes features, types and handling of exceptions.

Exceptions have close relation to the CPU core. Refer to “Cortex-M3 Technical Reference Manual” if needed.

### 8.1 Overview

An exception causes the CPU to stop the currently executing process and handle another process.

There are two types of exceptions: those that are generated when some error condition occurs or when an instruction to generate an exception is executed; and those that are generated by hardware, such as an interrupt request signal from an external pin or peripheral function.

All exceptions are handled by the Nested Vectored Interrupt Controller (NVIC) in the CPU according to the respective priority levels. When an exception occurs, the CPU stores the current state to the stack and branches to the corresponding interrupt service routine (ISR). Upon completion of the ISR, the information stored to the stack is automatically restored.

#### 8.1.1 Exception Types



The following types of exceptions exist in the Cortex-M3.

For detailed descriptions on each exception, refer to “Cortex-M3 Technical Reference Manual”.









- Reset
- Non-Maskable Interrupt (NMI)
- Hard Fault
- Memory Management
- Bus Fault
- Usage Fault
- SVCcall (Supervisor Call)
- Debug Monitor
- PendSV
- SysTick
- External Interrupt

### 8.1.2 Handling Flowchart

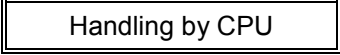
The following shows how an exception/interrupt is handled.

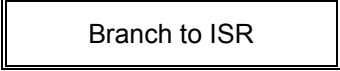
 indicates hardware handling.  Indicates software handling.

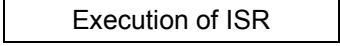
Each step is described later in this chapter.

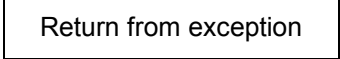
Processing	Description	See
	The CG/CPU detects the exception request.	Section 8.1.2.1
		
	The CPU handles the exception request.	Section 8.1.2.2
		
	The CPU branches to the corresponding interrupt service routine (ISR).	Section 8.1.2.3
		
	Necessary processing is executed.	Section 8.1.2.4
		
	The CPU branches to another ISR or returns to the previous program.	Section 8.1.2.4

### 8.1.2.1 Exception Request and Detection

#### (1) Exception occurrence

Exception sources include instruction execution by the CPU, memory accesses, and interrupt requests from external interrupt pins or peripheral functions.

An exception occurs when the CPU executes an instruction that causes an exception or when an error condition occurs during instruction execution.

An exception also occurs by an instruction fetch from the Execute Never (XN) region or an access violation to the Fault region.

An interrupt is generated from an external interrupt pin or peripheral function. For interrupts that are used for releasing a standby mode, relevant settings must be made in the clock generator. For details, refer to “8.5 Interrupts”.

#### (2) Exception detection

If multiple exceptions occur simultaneously, the CPU takes the exception with the highest priority.

Table 8-1 shows the priority of exceptions. “Configurable” means that you can assign a priority level to that exception. Memory Management, Bus Fault and Usage Fault exceptions can be enabled or disabled. If a disabled exception occurs, it is handled as Hard Fault.

Table 8-1 Exception Types and Priority

No.	Exception type	Priority	Description
1	Reset	-3 (highest)	Reset pin, WDT or SYSRETRREQ
2	Non-Maskable Interrupt	-2	NMI pin or WDT
3	Hard Fault	-1	Fault that cannot activate because a higher-priority fault is being handled or it is disabled
4	Memory Management	Configurable	Exception from the Memory Protection Unit (MPU) (Note 1) Instruction fetch from the Execute Never (XN) region
5	Bus Fault	Configurable	Access violation to the Hard Fault region of the memory map
6	Usage Fault	Configurable	Undefined instruction execution or other faults related to instruction execution
7-10	Reserved		
11	SVCcall	Configurable	System service call with SVC instruction
12	Debug Monitor	Configurable	Debug monitor when the core is not halting
13	Reserved		
14	PendSV	Configurable	Pendable system service request
15	SysTick	Configurable	Notification from system timer
16-	External Interrupt	Configurable	External interrupt pin or peripheral function (Note 2)

**(Note 1) This product does not contain the MPU.**

**(Note 2) External interrupts have different sources and numbers in each product. For details, see "List of Interrupt Sources".**

(3) Priority setting

• Priority level

Use the Interrupt Priority Registers to assign a priority to each of the external interrupts. The priority of other exceptions can be set in the System Handler Priority Registers.

The priority registers are configurable, allowing the number of bits for setting priority levels to vary between three to eight bits. Therefore, the range of priority levels that can be assigned vary with each product.

You can assign a priority level from 0 to 255 when using eight bits. Priority level 0 is the highest priority level.

If you assign the same priority level to multiple exceptions, the lowest-numbered exception has the highest priority.

**(ote) In this product, three bits are used for assigning a priority level in the Interrupt Priority Registers and System Handler Priority Registers.**

• Priority grouping

The priority group can be split into groups. By setting the <PRIGROUP> of the application interrupt and reset control register, <PRI\_n> can be divided into the pre-emption priority and the sub priority.

A priority is compared with the pre-emption priority. If the priority is the same as the preemption priority, then it is compared with the sub priority. If the sub priority is the same as the priority, the smaller the exception number, the higher the priority.

The following table shows the priority group setting. The pre-emption priority and the sub priority in the table are the number in the case that <PRI\_n> is defined as an 8-bit configuration.

Priority grouping setting

<PRIGROUP[2:0]> setting	<PRI_n[7:0]>		Number of pre-emption priorities	Number of subpriorities
	Pre-emption field	Subpriority field		
000	[7:1]	[0]	128	2
001	[7:2]	[1:0]	64	4
010	[7:3]	[2:0]	32	8
011	[7:4]	[3:0]	16	16
100	[7:5]	[4:0]	8	32
101	[7:6]	[5:0]	4	64
110	[7]	[6:0]	2	128
111	なし	[7:0]	1	256

Note: If the configuration of <PRI\_n> is less than 8 bits, the lower bit is "0". For the example, in the case of 3-bit configuration, the priority is set as <PRI\_n[7:5]> and <PRI\_n[4:0]> is "00000".

### 8.1.2.2 Exception Handling and Branch to the Interrupt Service Routine (Pre-emption)

When an exception occurs, the CPU suspends the currently executing process and branches to the interrupt service routine. This is called “pre-emption”.

#### (1) Stacking

When the CPU detects an exception, it pushes the contents of the following eight registers to the stack in the following order:

- Program Counter (PC)
- Program Status Register (xPSR)
- r0 - r3
- r12
- Link Register (LR)

The SP is decremented by eight words by the completion of the stack push. The following shows the state of the stack after the register contents have been pushed.

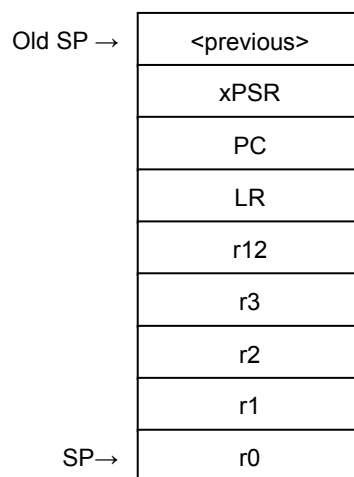

#### (2) Fetching an ISR

At the same time as pushing the register contents to the stack, the CPU executes an instruction to fetch an ISR.

Prepare a vector table containing the top addresses of ISRs for each exception. After reset, the vector table is located at address 0x0000\_0000 in the code space. By setting the Vector Table Offset Register, you can place the vector table at any address in the code or SRAM space.

The vector table should also contain the initial value of the main stack.

## (3) Late-arriving

If the CPU detects a higher priority exception before executing the ISR for a previous exception, the CPU handles the higher priority exception first. This is called “late-arriving”.

A late-arriving exception causes the CPU to fetch a new vector address for branching to the corresponding ISR, but the CPU does not newly push the register contents to the stack.

## (4) Vector table

The vector table is configured as shown below.

You must always set the first four words (stack top address, reset ISR address, NMI ISR address, and Hard Fault ISR address). Set ISR addresses for other exceptions if necessary.

Offset	Exception	Contents	Setting
0x00	Reset	Initial value of the main stack	Required
0x04	Reset	ISR address	Required
0x08	Non-Maskable Interrupt	ISR address	Required
0x0C	Hard Fault	ISR address	Required
0x10	Memory Management	ISR address	Optional
0x14	Bus Fault	ISR address	Optional
0x18	Usage Fault	ISR address	Optional
0x1C - 0x28	Reserved		
0x2C	SVCall	ISR address	Optional
0x30	Debug Monitor	ISR address	Optional
0x34	Reserved		
0x38	PendSV	ISR address	Optional
0x3C	SysTick	ISR address	Optional
0x40	External Interrupt	ISR address	Optional

### 8.1.2.3 Executing an ISR

An ISR performs necessary processing for the corresponding exception. ISRs must be prepared by the user.

An ISR may need to include code for clearing the interrupt request so that the same interrupt will not occur again upon return to normal program execution.

For details about interrupt handling, see “8.5 Interrupts”.

If a higher priority exception occurs during ISR execution for the current exception, the CPU abandons the currently executing ISR and services the newly detected exception.

### 8.1.2.4 Exception exit

#### (1) Execution after returning from an ISR

When returning from an ISR, the CPU takes one of the following actions:

- Tail-chaining

If a pending exception exists and there are no stacked exceptions or the pending exception has higher priority than all stacked exceptions, the CPU returns to the ISR of the pending exception.

In this case, the CPU skips the pop of eight registers and push of eight registers when exiting one ISR and entering another. This is called “tail-chaining”.

- Returning to the last stacked ISR

If there are no pending exceptions or if the highest priority stacked exception is of higher priority than the highest priority pending exception, the CPU returns to the last stacked ISR.

- Returning to the previous program

If there are no pending or stacked exceptions, the CPU returns to the previous program.

#### (2) Exception exit sequence

When returning from an ISR, the CPU performs the following operations:

- Pop eight registers

Pops the eight registers (PC, xPSR, r0 to r3, r12 and LR) from the stack and adjust the SP.

- Load current active interrupt number

Loads the current active interrupt number from the stacked xPSR. The CPU uses this to track which interrupt to return to.

- Select SP

If returning to an exception (Handler Mode), SP is SP\_main. If returning to Thread Mode, SP can be SP\_main or SP\_process.

## 8.2 Reset Exceptions

Reset exceptions are generated from the following three sources.

Use the Reset Flag (RSTFLG) Register of the Clock Generator to identify the source of a reset.

- External reset pin

A reset exception occurs when an external reset pin changes from “L” to “H”.

- Reset exception by WDT

The watchdog timer (WDT) has a reset generating feature. For details, see the chapter on the WDT.

- Reset exception by SYSRESETREQ

A reset can be generated by setting the SYSRESETREQ bit in the NVIC's Application Interrupt and Reset Control Register.

Note: Do not reset with <SYSRESETREQ> in SLOW mode.

## 8.3 Non-Maskable Interrupts (NMIs)

Non-maskable interrupts are generated from the following two sources.

Use the NMI Flag (NMIFLG) Register of the clock generator to identify the source of a non-maskable interrupt.

- External NMI pin

A non-maskable interrupt is generated when an external NMI pin changes from “H” to “L”.

- Non-maskable interrupt by WDT

The watchdog timer (WDT) has a non-maskable interrupt generating feature. For details, see the chapter on the WDT.

## 8.4 SysTick

SysTick provides interrupt features using the CPU's system timer.

When you set a value in the SysTick Reload Value Register and enable the SysTick features in the SysTick Control and Status Register, the counter loads with the value set in the Reload Value Register and begins counting down. When the counter reaches "0", a SysTick exception occurs. You may pend exceptions and use a flag to know when the timer reaches "0".

The SysTick Calibration Value Register holds a reload value for counting 10 ms with the system timer. The count clock frequency varies with each product, and so the value set in the SysTick Calibration Value Register also varies with each product.

<b>(Note)</b> In this product, $f_{osc}$ by 32 is used as external reference clock.
---

## 8.5 Interrupts

This chapter describes routes, sources and required settings of interrupts.

The CPU is notified of interrupt requests by the interrupt signal from each interrupt source. It sets priority on interrupts and handles an interrupt request with the highest priority.

Interrupt requests for clearing a standby mode are notified to the CPU via the clock generator. Therefore, appropriate settings must be made in the clock generator.

### 8.5.1 Interrupt Sources

#### 8.5.1.1 Interrupt Route

Fig. 8-1 shows an interrupt request route.

The interrupts issued by the peripheral function that is not used to release standby are directly input to the CPU (route1). The peripheral function interrupts used to release standby (route 2) and interrupts from the external interrupt pin (route 3) are input to the clock generator and are input to the CPU through the logic for releasing standby (route 4 and 5). If interrupts from the external interrupt pins are not used to release standby, they are directly input to the CPU, not through the logic for standby release (route 6).

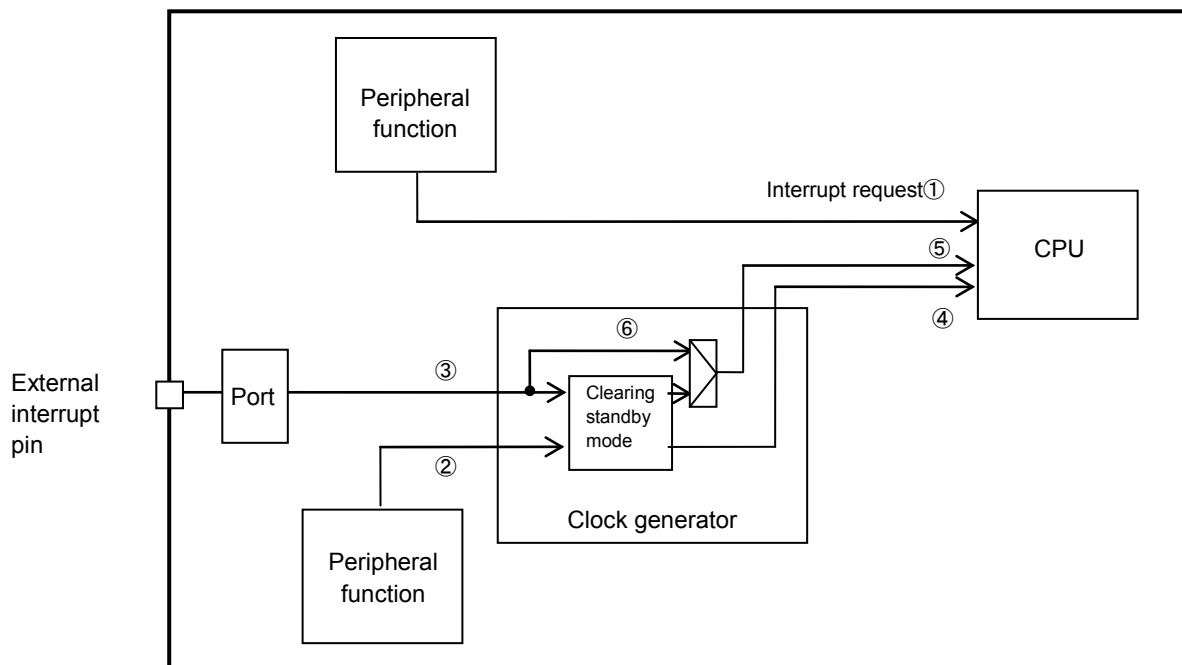

Fig. 8-1 Interrupt Route

### 8.5.1.2 Generation

An interrupt request is generated from an external pin or peripheral function assigned as an interrupt source or by setting the NVIC's Interrupt Set-Pending Register.

- From external pin

Set the port control register so that the external pin can perform as an interrupt function pin.

- From peripheral function

Set the peripheral function to make it possible to output interrupt requests.

See the chapter of each peripheral function for details.

- By setting Interrupt Set-Pending Register (forced pending)

An interrupt request can be generated by setting the relevant bit of the Interrupt Set-Pending Register.

### 8.5.1.3 Transmission

An interrupt signal from an external pin or peripheral function is directly sent to the CPU unless it is used to clear a standby mode.

Interrupt requests from interrupt sources that can be used for clearing a standby mode are transmitted to the CPU via the clock generator. For these interrupt sources, appropriate settings must be made in the clock generator in advance. External interrupt sources not used for clearing a standby mode can be used without setting the clock generator.

### 8.5.1.4 Precautions when using external interrupt pins

If you use external interrupts, be aware the followings not to generate unexpected interrupts.

If input disabled (PxIE<PxMIIE>="0"), inputs from external interrupt pins are "High". Also, if external interrupts are not used as a trigger to release standby (route 6 of "Figure 7-1 Interrupt Route"), input signals from the external interrupt pins are directly sent to the CPU. Since the CPU recognizes "High" input as an interrupt, interrupts occur if corresponding interrupts are enabled by the CPU as inputs are being disabled.

To use the external interrupt without setting it as a standby trigger, set the interrupt pin input as "Low" and enable it. Then, enable interrupts on the CPU.

## 8.5.1.5 List of Interrupt Sources

Table 8-2 shows the list of interrupt sources.

Table 8-2 List of Hardware Interrupt Sources (1/2)

No.	Interrupt Source		Active state (Clearing standby)	CG interrupt mode control register		
0	INT0	Interrupt pin (PJ0/70pin)	Selectable	IMCGA		
1	INT1	Interrupt pin (PJ1/49pin)				
2	INT2	Interrupt pin (PJ2/86pin)				
3	INT3	Interrupt pin (PJ3/87pin)				
4	INT4	Interrupt pin (PG3/6pin)				
5	INT5	Interrupt pin (PF7/19pin)				
6	INTRX0	Serial reception (channel.0)				
7	INTTX0	Serial transmission (channel.0)				
8	INTRX1	Serial reception (channel.1)				
9	INTTX1	Serial transmission (channel.1)				
10	INTSBI0	Serial bus interface 0				
11	INTSBI1	Serial bus interface 1				
12	INTCECRX	CEC reception			Rising edge	IMCGB
13	INTCECTX	CEC transmission				IMCGD
14	INTRMCRX0	Remote control signal reception (channel.0)				IMCGB
15	INTADHP	Highest priority AD conversion complete interrupt				
16	INTADM0	AD conversion monitoring function interrupt 0				
17	INTADM1	AD conversion monitoring function interrupt 1				
18	INTTB0	16bit TMRB match detection 0				
19	INTTB1	16bit TMRB match detection 1				
20	INTTB2	16bit TMRB match detection 2				
21	INTTB3	16bit TMRB match detection 3				
22	INTTB4	16bit TMRB match detection 4				
23	INTTB5	16bit TMRB match detection 5				
24	INTTB6	16bit TMRB match detection 6				
25	INTRTC	Real time clock timer	Falling edge	IMCGC		
26	INTCAP00	16bit TMRB input capture 00				
27	INTCAP01	16bit TMRB input capture 01				
28	INTCAP10	16bit TMRB input capture 10				
29	INTCAP11	16bit TMRB input capture 11				
30	INTCAP50	16bit TMRB input capture 50				
31	INTCAP51	16bit TMRB input capture 51				
32	INTCAP60	16bit TMRB input capture 60				
33	INTCAP61	16bit TMRB Input capture 61				
34	INT6	Interrupt pin (PJ6/39pin)			Selectable	IMCGC
35	INT7	Interrupt pin (PJ7/58pin)				
36	INTRX2	Serial reception (channel.2)				
37	INTTX2	Serial transmission (channel.2)				
38	INTSBI2	Serial bus interface 2				
39	INTRMCRX1	Remote control signal reception (channel.1)			Rising edge	IMCGC
40	INTTB7	16bit TMRB match detection 7				
41	INTTB8	16bit TMRB match detection 8				
42	INTTB9	16bit TMRB match detection 9				

Table 8-2 List of Hardware Interrupt Sources (2/2)

No.	Interrupt Sources		Active state (Clearing standby)	Clock Generator
43	INTCAP20	16bit TMRB input capture 20		
44	INTCAP21	16bit TMRB input capture 21		
45	INTCAP30	16bit TMRB input capture 30		
46	INTCAP31	16bit TMRB input capture 31		
47	INTCAP40	16bit TMRB input capture 40		
48	INTCAP41	16bit TMRB input capture 41		
49	INTAD	A/D conversion completion		

#### 8.5.1.6 Active State

The active state indicates which change in signal of an interrupt source triggers an interrupt. The CPU detects an interrupt request when an interrupt signal changes from “L” to “H”. Interrupt signals directly sent from peripheral functions to the CPU are configured to output “H” to indicate an interrupt request.

Interrupt requests from peripheral functions are set as rising-edge or falling-edge triggered. Interrupt requests from interrupt pins can be set as level-sensitive (“H” or “L”) or edge-triggered (rising or falling).

If an interrupt source is used for clearing a standby mode, setting the relevant clock generator register is also required. Enable the CGIMCGx<INTxEN> bit and specify the active state in the CGIMCGx<EMCG[2:0]> bits. You must set the active state for interrupt requests from each peripheral function as shown in Table 8-2.

An interrupt request detected by the clock generator is notified to the CPU with a signal in “H” level.



Interrupt requests from interrupt pins can be used without setting the clock generator if they are not used for clearing a standby mode. However, an “H” pulse or “H”-level signal must be input so that the CPU can detect it as an interrupt request.

**(Note)** For the CEC reception/transmission, remote control signal reception and real time clock timer interrupts, set the <INTxEN>bit to “1” and specify the active state as shown in Table 8-2, even when they are not used for clearing a standby mode.

## 8.5.2 Interrupt Handling

### 8.5.2.1 Flowchart

The following shows how an interrupt is handled.

 indicates hardware handling.  indicates software handling.

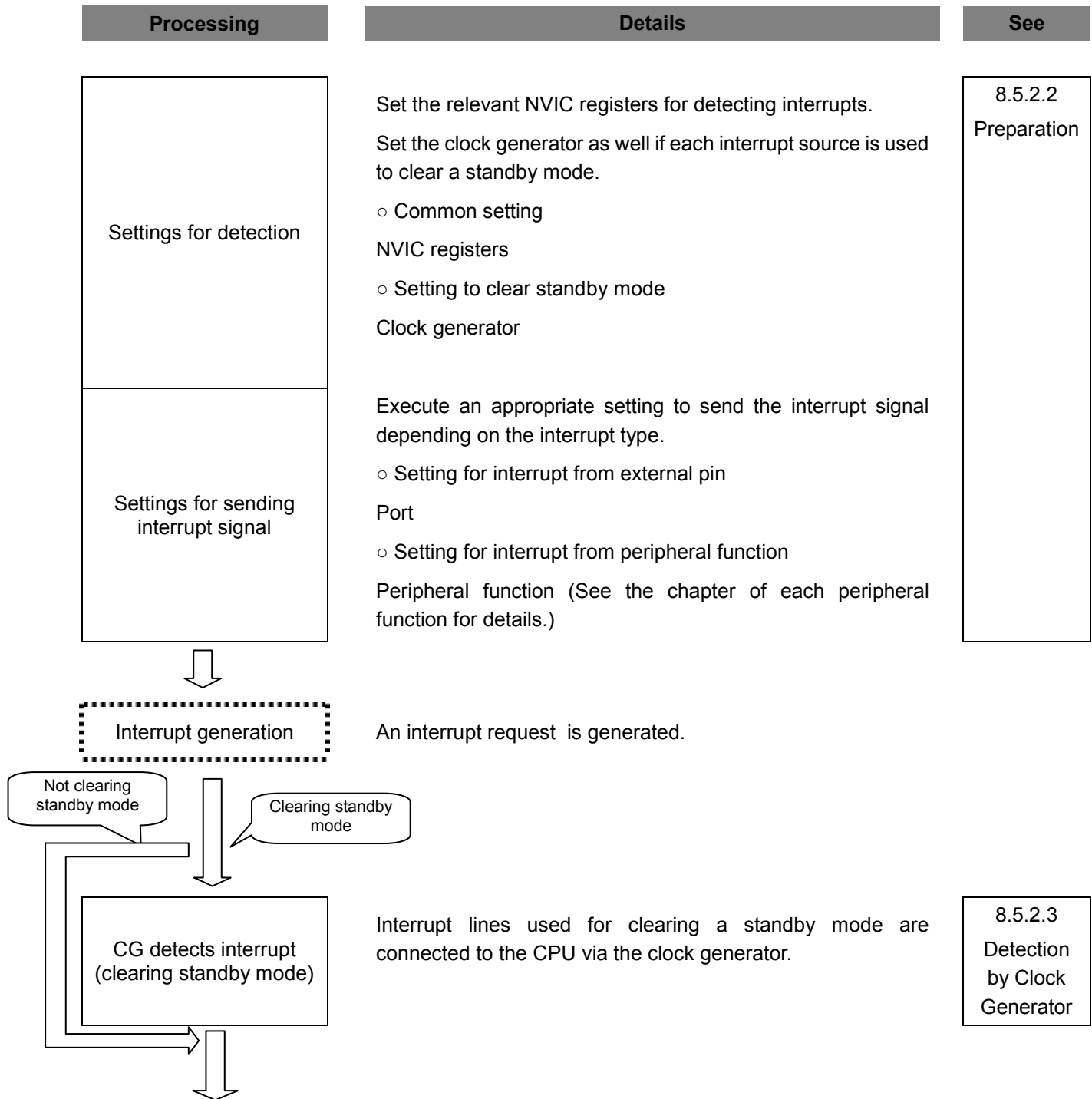

Processing	Details	See
<div style="text-align: center;">↓</div> <div style="border: 1px solid black; padding: 5px; text-align: center;">CPU detects interrupt</div>	<p>The CPU detects the interrupt.</p> <p>If multiple interrupt requests occur simultaneously, the interrupt request with the highest priority is detected according to the priority order.</p>	<div style="border: 1px solid black; padding: 5px; text-align: center;">8.5.2.4 Detection by CPU</div>
<div style="text-align: center;">↓</div> <div style="border: 1px solid black; padding: 5px; text-align: center;">CPU handles interrupt</div>	<p>The CPU handles the interrupt.</p> <p>The CPU pushes register contents to the stack before entering the ISR.</p>	<div style="border: 1px solid black; padding: 5px; text-align: center;">8.5.2.5 CPU processing</div>
<div style="text-align: center;">↓</div> <div style="border: 1px solid black; padding: 5px; text-align: center;">ISR execution</div>	<p>Program for the ISR. Clear the interrupt source if needed.</p>	<div style="border: 1px solid black; padding: 5px; text-align: center;">8.5.2.6 Interrupt Service Routine (ISR)</div>
<div style="text-align: center;">↓</div> <div style="border: 1px solid black; padding: 5px; text-align: center;">Return to preceding program</div>	<p>Configure to return to the preceding program of the ISR.</p>	

### 8.5.2.2 Preparation

When preparing for an interrupt, you need to pay attention to the order of configuration to avoid any unexpected interrupt on the way.

Initiating an interrupt or changing its configuration must be implemented in the following order basically. Disable the interrupt by the CPU. Configure from the farthest route from the CPU. Then enable the interrupt by the CPU.

To configure the clock generator, you must follow the order indicated here not to cause any unexpected interrupt. First, configure the precondition. Secondly, clear the data related to the interrupt in the clock generator and then enable the interrupt.

The following sections are listed in the order of interrupt handling and describe how to configure them.

- (1) Disabling interrupt by CPU
- (2) CPU registers setting
- (3) Preconfiguration 1 (Interrupt from external pin)
- (4) Preconfiguration 2 (interrupt from peripheral function)
- (5) Preconfiguration 3 (Interrupt Set-Pending Register)
- (5) Configuring the clock generator
- (6) Enabling interrupt by CPU

(1) Disabling interrupt by CPU

To make the CPU for not accepting any interrupt, write "1" to the corresponding bit of the PRIMASK Register. Each bit of the register, of which default setting is disabled, is assigned to a single interrupt source.

• Interrupt mask register		
PRIMASK	←	"1" (interrupt disabled)

(Note) m: corresponding bit

## (2) CPU registers setting

You can assign a priority level to each interrupt source in the corresponding Interrupt Priority Register of the NVIC.

Each interrupt source is provided with eight bits for assigning a priority level from 0 to 255, but the number of bits actually used varies with each product. Priority level 0 is the highest priority level. If multiple sources have the same priority, the smallest-numbered interrupt source has the highest priority.

●NVIC register		
Interrupt Priority<m>	←	“priority”

(Note) m: corresponding bit

This product uses three bits for assigning a priority level.

## (3) Preconfiguration 1 (Interrupt from external pin)

Set “1” to the port function register of the corresponding pin. Setting PnFRx[m] allows the pin to be used as the function pin. Setting PnIE[m] allows the pin to be used as the input port.

● Port register		
PnFRx<PnmFRx>	←	“1”
PnIE<PnmIE>	←	“1”

(Note) n: port number  
m: corresponding bit  
x: function register number

In modes other than STOP mode, setting PnIE to enable input enables the corresponding interrupt input regardless of the PnFR setting. Be careful not to enable interrupts that are not used.

## (4) Preconfiguration 2 (interrupt from peripheral function)

The setting varies depending on the peripheral function to be used. See the chapter of each peripheral function for details.

## (5) Preconfiguration 3 (Interrupt Set-Pending Register)

To generate an interrupt by using the Interrupt Set-Pending Register, set “1” to the corresponding bit of this register.

● NVIC register		
Interrupt Set-Pending<m>	←	“1”

(Note) m: corresponding bit

## (6) Configuring the clock generator

For an interrupt source to be used for clearing a standby mode, you need to set the active state and enable interrupts in the CGIMCG register of the clock generator. The CGIMCG register is capable of configuring each source.

Before enabling an interrupt, clear the corresponding interrupt request already held. This can avoid unexpected interrupt. To clear corresponding interrupt request, write a value corresponding to the interrupt to be used to the CGICRCG register. See 8.6.3.5 CG Interrupt Request Clear Register for each value.

Interrupt requests from external pins can be used without setting the clock generator if they are not used for clearing a standby mode. However, an “H” pulse or “H”-level signal must be input so that the CPU can detect it as an interrupt request.

• Clock generator register		
CGIMCGn<EMCGm>	←	Active state
CGICRCG<ICRCG>	←	Value corresponding to the interrupt to be used
CGIMCGn<INTmEN>	←	“1” (interrupt enabled)

(Note) n: register number  
m: number assigned to interrupt source

## (7) Enabling interrupt by CPU

Enable the interrupt by the CPU as shown below.

Clear the suspended interrupt in the Interrupt Clear-Pending Register. Enable the intended interrupt with the Interrupt Set-Enable Register. Each bit of the register is assigned to a single interrupt source.

Writing “1” to the corresponding bit of the Clear-Pending Register clears the suspended interrupt. Writing “1” to the corresponding bit of the Set-Enable Register enables the intended interrupt.

If the Interrupt Set-Pending Register is used for generating an interrupt, setting of the Clear-Pending Register is not needed as this operation will cause an interrupt request to be cleared.

•NVIC register		
Interrupt Clear-Pending<m>	←	“1”
Interrupt Set-Enable<m>	←	“1”
• Interrupt mask register		
PRIMASK	←	“0”

(Note) m: corresponding bit

### 8.5.2.3 Detection by Clock Generator

If an interrupt source is used for clearing a standby mode, an interrupt request is detected according to the active level specified in the clock generator, and is notified to the CPU.

An edge-triggered interrupt request, once detected, is held in the clock generator. A level-sensitive interrupt request must be held at the active level until it is detected, otherwise the interrupt request will cease to exist when the signal level changes from active to inactive.

When the clock generator detects an interrupt request, it keeps sending the interrupt signal in “H” level to the CPU until the interrupt request is cleared in the CG Interrupt Request Clear (CGICRCG) Register. If a standby mode is exited without clearing the interrupt request, the same interrupt will be detected again when normal operation is resumed. Be sure to clear each interrupt request in the ISR.

### 8.5.2.4 Detection by CPU

The CPU detects an interrupt request with the highest priority.

### 8.5.2.5 CPU processing

On detecting an interrupt, the CPU pushes the contents of PC, PSR, r0-r3, r12 and LR to the stack before entering the ISR.

### 8.5.2.6 Interrupt Service Routine (ISR)

An ISR requires specific programming according to the application to be used. This section describes what is recommended at the service routine programming and how the source is cleared.

(1) Pushing during ISR

An ISR normally pushes register contents to the stack and handles an interrupt as required. The Cortex-M3 core automatically pushes the contents of PC, PSR, r0-r3, r12 and LR to the stack. No extra programming is required for them.

Push the contents of other registers if needed.

Interrupt requests with higher priority and exceptions such as NMI are accepted even when an ISR is being executed. We recommend you to push the contents of general-purpose registers that might be rewritten.

(2) Clearing an interrupt source

If an interrupt source is used for clearing a standby mode, each interrupt request must be cleared with the CG Interrupt Request Clear (CGICRCG) Register.

If an interrupt source is set as level-sensitive, an interrupt request continues to exist until it is cleared at its source. Therefore, the interrupt source must be cleared. Clearing the interrupt source automatically clears the interrupt request signal from the clock generator.

If an interrupt is set as edge-sensitive, clear an interrupt request by setting the corresponding value in the CGICRCG register. When an active edge occurs again, a new interrupt request will be detected.

## 8.6 Exception/Interrupt-Related Registers

The CPU's NVIC registers and clock generator registers described in this chapter are shown below with their respective addresses.

### 8.6.1 Register List

•NVIC registers	
SysTick Control and Status Register	0xE000_E010
SysTick Reload Value Register	0xE000_E014
SysTick Current Value Register	0xE000_E018
SysTick Calibration Value Register	0xE000_E01C
Interrupt Set-Enable Register 1	0xE000_E100
Interrupt Set-Enable Register 2	0xE000_E104
Interrupt Clear-Enable Register 1	0xE000_E180
Interrupt Clear-Enable Register 2	0xE000_E184
Interrupt Set-Pending Register 1	0xE000_E200
Interrupt Set-Pending Register 2	0xE000_E204
Interrupt Clear-Pending Register 1	0xE000_E280
Interrupt Clear-Pending Register 2	0xE000_E284
Interrupt Priority Register	0xE000_E400-0xE000_E430
Vector Table Offset Register	0xE000_ED08
System Handler Priority Register	0xE000_ED18,0xE000_ED1C,0xE000_ED20
System Handler Control and State Register	0xE000_ED24

• Clock generator registers		
CGICRCG	CG Interrupt Request Clear Register	0x4004_0214
CGNMIFLG	NMI Flag Register	0x4004_0218
CGRSTFLG	Reset Flag Register	0x4004_021C
CGIMCGA	CG Interrupt Mode Control Register A	0x4004_0220
CGIMCGB	CG Interrupt Mode Control Register B	0x4004_0224
CGIMCGC	CG Interrupt Mode Control Register C	0x4004_0228
CGIMCGD	CG Interrupt Mode Control Register D	0x4004_022C

8.6.2 NVIC Registers

8.6.2.1 SysTick Control and Status Register

	7	6	5	4	3	2	1	0
bit Symbol						CLK SOURC E	TICKIN T	ENABL E
Read/Write	R					R/W	R/W	R/W
After reset	0					0	0	0
Function	"0" is read.					0: External reference clock 1: Core clock	0: Do not pend SysTick 1: Pend SysTick	0: Disable 1: Enable
	15	14	13	12	11	10	9	8
bit Symbol								
Read/Write	R							
After reset	0							
Function	"0" is read.							
	23	22	21	20	19	18	17	16
bit Symbol								COUNT FLAG
Read/Write	R							R/W
After reset	0							0
Function	"0" is read.							0: Timer not counted to 0 1: Timer counted to 0
	31	30	29	28	27	26	25	24
bit Symbol								
Read/Write	R							
After reset	0							
Function	"0" is read.							

- <bit0> <ENABLE> 1 = The counter loads with the Reload value and then begins counting down.  
0 = The timer is disabled.
- <bit1> <TICKINT> 1 = SysTick exceptions are pending.  
0 = SysTick exceptions are not pending.
- <bit2> <CLKSOURCE> 0 = External reference clock (fosc/32)  
1 = Core clock (fsys)
- <bit16> <COUNTFLAG> 1 = Indicates that the timer counted to 0 since last time this was read.  
Clears on read of any part of the SysTick Control and Status Register.

Note: In this product, fosc by 32 is used as external reference clock.

## 8.6.2.2 SysTick Reload Value Register

	7	6	5	4	3	2	1	0
bit Symbol	RELOAD							
Read/Write	R/W							
After reset	Undefined							
Function	Reload value							
	15	14	13	12	11	10	9	8
bit Symbol	RELOAD							
Read/Write	R/W							
After reset	Undefined							
Function	Reload value							
	23	22	21	20	19	18	17	16
bit Symbol	RELOAD							
Read/Write	R/W							
After reset	Undefined							
Function	Reload value							
	31	30	29	28	27	26	25	24
bit Symbol	/							
Read/Write	R							
After reset	0							
Function	"0" is read.							

<bit23:0> <RELOAD> Set the value to load into the SysTick Current Value Register when the timer reaches "0".

8.6.2.3 SysTick Current Value Register

	7	6	5	4	3	2	1	0
bit Symbol	CURRENT							
Read/Write	R/W							
After reset	Undefined							
Function	[Read] Current SysTick timer value [Write] Clear							
	15	14	13	12	11	10	9	8
bit Symbol	CURRENT							
Read/Write	R/W							
After reset	Undefined							
Function	[Read] Current SysTick timer value [Write] Clear							
	23	22	21	20	19	18	17	16
bit Symbol	CURRENT							
Read/Write	R/W							
After reset	Undefined							
Function	[Read] Current SysTick timer value [Write] Clear							
	31	30	29	28	27	26	25	24
bit Symbol	/							
Read/Write	R							
After reset	0							
Function	"0" is read.							

<bit23:0> <CURRENT> [Read] Current SysTick timer value.  
 [Write] Writing to this register with any value clears it to 0. Clearing this register also clears the COUNTFLAG bit of the SysTick Control and Status Register.

## 8.6.2.4 SysTick Calibration Value Register

	7	6	5	4	3	2	1	0
bit Symbol	TENMS							
Read/Write	R							
After reset	1	1	0	0	0	1	0	0
Function	Calibration value (Note)							
	15	14	13	12	11	10	9	8
bit Symbol	TENMS							
Read/Write	R							
After reset	0	0	0	0	1	0	0	1
Function	Calibration value (Note)							
	23	22	21	20	19	18	17	16
bit Symbol	TENMS							
Read/Write	R							
After reset	0	0	0	0	0	0	0	0
Function	Calibration value (Note)							
	31	30	29	28	27	26	25	24
bit Symbol	NOREF	SKEW						
Read/Write	RR	R0	R					
After reset	0	0	0					
Function	0: Reference clock provided 1: No reference clock	0: Calibration value is 10 ms. 1: Calibration value is not 10 ms.	"0" is read.					

<bit23:0> <TENMS> Reload value to use for 10 ms timing (0x9C4). (Note)

<bit30> <SKEW> 1 = The calibration value is not exactly 10 ms.

<bit31> <NOREF> 1 = The reference clock is not provided.

**(Note)** In this product, the system timer counts based on a clock obtained by dividing the clock input from the X1 pin by 32. The SysTick Calibration Value Register is set to a value that provides 10 ms timing when the clock input from X1 is 8 MHz.

In the case of a multishot, please use <TENMS>-1.

## 8.6.2.5 Interrupt Set-Enable Register 1

	7	6	5	4	3	2	1	0	
bit Symbol	SETENA								
Read/Write	R/W								
After reset	0	0	0	0	0	0	0	0	
Function	Interrupt number 7 [Write] 1: Enable [Read] 0: Disabled 1: Enabled	Interrupt number 6 [Write] 1: Enable [Read] 0: Disabled 1: Enabled	Interrupt number 5 [Write] 1: Enable [Read] 0: Disabled 1: Enabled	Interrupt number 4 [Write] 1: Enable [Read] 0: Disabled 1: Enabled	Interrupt number 3 [Write] 1: Enable [Read] 0: Disabled 1: Enabled	Interrupt number 2 [Write] 1: Enable [Read] 0: Disabled 1: Enabled	Interrupt number 1 [Write] 1: Enable [Read] 0: Disabled 1: Enabled	Interrupt number 0 [Write] 1: Enable [Read] 0: Disabled 1: Enabled	
	15	14	13	12	11	10	9	8	
bit Symbol	SETENA								
Read/Write	R/W								
After reset	0	0	0	0	0	0	0	0	
Function	Interrupt number 15 [Write] 1: Enable [Read] 0: Disabled 1: Enabled	Interrupt number 14 [Write] 1: Enable [Read] 0: Disabled 1: Enabled	Interrupt number 13 [Write] 1: Enable [Read] 0: Disabled 1: Enabled	Interrupt number 12 [Write] 1: Enable [Read] 0: Disabled 1: Enabled	Interrupt number 11 [Write] 1: Enable [Read] 0: Disabled 1: Enabled	Interrupt number 10 [Write] 1: Enable [Read] 0: Disabled 1: Enabled	Interrupt number 9 [Write] 1: Enable [Read] 0: Disabled 1: Enabled	Interrupt number 8 [Write] 1: Enable [Read] 0: Disabled 1: Enabled	
	23	22	21	20	19	18	17	16	
bit Symbol	SETENA								
Read/Write	R/W								
After reset	0	0	0	0	0	0	0	0	
Function	Interrupt number 23 [Write] 1: Enable [Read] 0: Disabled 1: Enabled	Interrupt number 22 [Write] 1: Enable [Read] 0: Disabled 1: Enabled	Interrupt number 21 [Write] 1: Enable [Read] 0: Disabled 1: Enabled	Interrupt number 20 [Write] 1: Enable [Read] 0: Disabled 1: Enabled	Interrupt number 19 [Write] 1: Enable [Read] 0: Disabled 1: Enabled	Interrupt number 18 [Write] 1: Enable [Read] 0: Disabled 1: Enabled	Interrupt number 17 [Write] 1: Enable [Read] 0: Disabled 1: Enabled	Interrupt number 16 [Write] 1: Enable [Read] 0: Disabled 1: Enabled	
	31	30	29	28	27	26	25	24	
bit Symbol	SETENA								
Read/Write	R/W								
After reset	00	00	00	0	0	0	0	0	
Function	Interrupt number 31 [Write] 1: Enable [Read] 0: Disabled 1: Enabled	Interrupt number 30 [Write] 1: Enable [Read] 0: Disabled 1: Enabled	Interrupt number 29 [Write] 1: Enable [Read] 0: Disabled 1: Enabled	Interrupt number 28 [Write] 1: Enable [Read] 0: Disabled 1: Enabled	Interrupt number 27 [Write] 1: Enable [Read] 0: Disabled 1: Enabled	Interrupt number 26 [Write] 1: Enable [Read] 0: Disabled 1: Enabled	Interrupt number 25 [Write] 1: Enable [Read] 0: Disabled 1: Enabled	Interrupt number 24 [Write] 1: Enable [Read] 0: Disabled 1: Enabled	

<bit31:0> <SETENA> Use these bits to enable interrupts or determine which interrupts are currently enabled.

Writing “1” to a bit in this register enables the corresponding interrupt. Writing “0” has no effect.

Reading a bit in this register returns the current state of the corresponding interrupt as shown below.

0 = Disabled  
1 = Enabled

**(Note) For descriptions of interrupts and interrupt numbers, see Section 8.5.1.4 List of Interrupt Sources.**

8.6.2.6 Interrupt Set-Enable Register 2

	7	6	5	4	3	2	1	0
bit Symbol	SETENA							
Read/Write	R/W							
After reset	0	0	0	0	0	0	0	0
Function	Interrupt number 39 [Write] 1: Enable [Read] 0: Disabled 1: Enabled	Interrupt number 38 [Write] 1: Enable [Read] 0: Disabled 1: Enabled	Interrupt number 37 [Write] 1: Enable [Read] 0: Disabled 1: Enabled	Interrupt number 36 [Write] 1: Enable [Read] 0: Disabled 1: Enabled	Interrupt number 35 [Write] 1: Enable [Read] 0: Disabled 1: Enabled	Interrupt number 34 [Write] 1: Enable [Read] 0: Disabled 1: Enabled	Interrupt number 33 [Write] 1: Enable [Read] 0: Disabled 1: Enabled	Interrupt number 32 [Write] 1: Enable [Read] 0: Disabled 1: Enabled
	15	14	13	12	11	10	9	8
bit Symbol	SETENA							
Read/Write	R/W							
After reset	0	0	0	0	0	0	0	0
Function	Interrupt number 47 [Write] 1: Enable [Read] 0: Disabled 1: Enabled	Interrupt number 46 [Write] 1: Enable [Read] 0: Disabled 1: Enabled	Interrupt number 45 [Write] 1: Enable [Read] 0: Disabled 1: Enabled	Interrupt number 44 [Write] 1: Enable [Read] 0: Disabled 1: Enabled	Interrupt number 43 [Write] 1: Enable [Read] 0: Disabled 1: Enabled	Interrupt number 42 [Write] 1: Enable [Read] 0: Disabled 1: Enabled	Interrupt number 41 [Write] 1: Enable [Read] 0: Disabled 1: Enabled	Interrupt number 40 [Write] 1: Enable [Read] 0: Disabled 1: Enabled
	23	22	21	20	19	18	17	16
bit Symbol							SETENA	
Read/Write	R						R/W	
After reset	0						0	0
Function	"0" is read.						Interrupt number 49 [Write] 1: Enable [Read] 0: Disabled 1: Enabled	Interrupt number 48 [Write] 1: Enable [Read] 0: Disabled 1: Enabled
	31	30	29	28	27	26	25	24
bit Symbol								
Read/Write	R							
After reset	0							
Function	"0" is read.							

<bit17:0> <SETENA> Use these bits to enable interrupts or determine which interrupts are currently enabled.

Writing "1" to a bit in this register enables the corresponding interrupt. Writing "0" has no effect.

Reading a bit in this register returns the current state of the corresponding interrupt as shown below.

0 = Disabled  
1 = Enabled

**(Note) For descriptions of interrupts and interrupt numbers, see Section 8.5.1.4 List of Interrupt Sources.**

8.6.2.7 Interrupt Clear-Enable Register

	7	6	5	4	3	2	1	0
bit Symbol	CLRENA							
Read/Write	R/W							
After reset	0	0	0	0	0	0	0	0
Function	Interrupt number 7 [Write] 1: Disable [Read] 0: Disabled 1: Enabled	Interrupt number 6 [Write] 1: Disable [Read] 0: Disabled 1: Enabled	Interrupt number 5 [Write] 1: Disable [Read] 0: Disabled 1: Enabled	Interrupt number 4 [Write] 1: Disable [Read] 0: Disabled 1: Enabled	Interrupt number 3 [Write] 1: Disable [Read] 0: Disabled 1: Enabled	Interrupt number 2 [Write] 1: Disable [Read] 0: Disabled 1: Enabled	Interrupt number 1 [Write] 1: Disable [Read] 0: Disabled 1: Enabled	Interrupt number 0 [Write] 1: Disable [Read] 0: Disabled 1: Enabled
	15	14	13	12	11	10	9	8
bit Symbol	CLRENA							
Read/Write	R/W							
After reset	0	0	0	0	0	0	0	0
Function	Interrupt number 15 [Write] 1: Disable [Read] 0: Disabled 1: Enabled	Interrupt number 14 [Write] 1: Disable [Read] 0: Disabled 1: Enabled	Interrupt number 13 [Write] 1: Disable [Read] 0: Disabled 1: Enabled	Interrupt number 12 [Write] 1: Disable [Read] 0: Disabled 1: Enabled	Interrupt number 11 [Write] 1: Disable [Read] 0: Disabled 1: Enabled	Interrupt number 10 [Write] 1: Disable [Read] 0: Disabled 1: Enabled	Interrupt number 9 [Write] 1: Disable [Read] 0: Disabled 1: Enabled	Interrupt number 8 [Write] 1: Disable [Read] 0: Disabled 1: Enabled
	23	22	21	20	19	18	17	16
bit Symbol	CLRENA							
Read/Write	R/W							
After reset	0	0	0	0	0	0	0	0
Function	Interrupt number 23 [Write] 1: Disable [Read] 0: Disabled 1: Enabled	Interrupt number 22 [Write] 1: Disable [Read] 0: Disabled 1: Enabled	Interrupt number 21 [Write] 1: Disable [Read] 0: Disabled 1: Enabled	Interrupt number 20 [Write] 1: Disable [Read] 0: Disabled 1: Enabled	Interrupt number 19 [Write] 1: Disable [Read] 0: Disabled 1: Enabled	Interrupt number 18 [Write] 1: Disable [Read] 0: Disabled 1: Enabled	Interrupt number 17 [Write] 1: Disable [Read] 0: Disabled 1: Enabled	Interrupt number 16 [Write] 1: Disable [Read] 0: Disabled 1: Enabled
	31	30	29	28	27	26	25	24
bit Symbol	CLRENA							
Read/Write	R/W							
After reset	0	0	0	0	0	0	0	0
Function	Interrupt number 31 [Write] 1: Disable [Read] 0: Disabled 1: Enabled	Interrupt number 30 [Write] 1: Disable [Read] 0: Disabled 1: Enabled	Interrupt number 29 [Write] 1: Disable [Read] 0: Disabled 1: Enabled	Interrupt number 28 [Write] 1: Disable [Read] 0: Disabled 1: Enabled	Interrupt number 27 [Write] 1: Disable [Read] 0: Disabled 1: Enabled	Interrupt number 26 [Write] 1: Disable [Read] 0: Disabled 1: Enabled	Interrupt number 25 [Write] 1: Disable [Read] 0: Disabled 1: Enabled	Interrupt number 24 [Write] 1: Disable [Read] 0: Disabled 1: Enabled

<bit31:0> <CLRENA> Use these bits to disable or determine which interrupts are currently disabled.

Writing “1” to a bit in this register disables the corresponding interrupt. Writing “0” has no effect.

Reading a bit in this register returns the current state of the corresponding interrupt as shown below.

0 = Disabled  
1 = Enabled

**(Note) For descriptions of interrupts and interrupt numbers, see Section 8.5.1.4 List of Interrupt Sources.**

## 8.6.2.8 Interrupt Clear-Enable Register 2

	7	6	5	4	3	2	1	0
bit Symbol	CLRENA							
Read/Write	R/W							
After reset	0	0	0	0	0	0	0	0
Function	Interrupt number 39 [Write] 1: Disable [Read] 0: Disabled 1: Enabled	Interrupt number 38 [Write] 1: Disable [Read] 0: Disabled 1: Enabled	Interrupt number 37 [Write] 1: Disable [Read] 0: Disabled 1: Enabled	Interrupt number 36 [Write] 1: Disable [Read] 0: Disabled 1: Enabled	Interrupt number 35 [Write] 1: Disable [Read] 0: Disabled 1: Enabled	Interrupt number 34 [Write] 1: Disable [Read] 0: Disabled 1: Enabled	Interrupt number 33 [Write] 1: Disable [Read] 0: Disabled 1: Enabled	Interrupt number 32 [Write] 1: Disable [Read] 0: Disabled 1: Enabled
	15	14	13	12	11	10	9	8
bit Symbol	CLRENA							
Read/Write	R/W							
After reset	0	0	0	0	0	0	0	0
Function	Interrupt number 47 [Write] 1: Disable [Read] 0: Disabled 1: Enabled	Interrupt number 46 [Write] 1: Disable [Read] 0: Disabled 1: Enabled	Interrupt number 45 [Write] 1: Disable [Read] 0: Disabled 1: Enabled	Interrupt number 44 [Write] 1: Disable [Read] 0: Disabled 1: Enabled	Interrupt number 43 [Write] 1: Disable [Read] 0: Disabled 1: Enabled	Interrupt number 42 [Write] 1: Disable [Read] 0: Disabled 1: Enabled	Interrupt number 41 [Write] 1: Disable [Read] 0: Disabled 1: Enabled	Interrupt number 40 [Write] 1: Disable [Read] 0: Disabled 1: Enabled
	23	22	21	20	19	18	17	16
bit Symbol							CLRENA	
Read/Write	R						R/W	
After reset	0						0	0
Function	"0" is read.						Interrupt number 49 [Write] 1: Disable [Read] 0: Disabled 1: Enabled	Interrupt number 48 [Write] 1: Disable [Read] 0: Disabled 1: Enabled
	31	30	29	28	27	26	25	24
bit Symbol								
Read/Write	R							
After reset	0							
Function	"0" is read.							

<bit17:0> <CLRENA> Use these bits to disable or determine which interrupts are currently disabled.

Writing "1" to a bit in this register disables the corresponding interrupt. Writing "0" has no effect.

Reading a bit in this register returns the current state of the corresponding interrupt as shown below.

0 = Disabled

1 = Enabled

**(Note) For descriptions of interrupts and interrupt numbers, see Section 8.5.1.4 List of Interrupt Sources.**

8.6.2.9 Interrupt Set-Pending Register 1

	7	6	5	4	3	2	1	0
bit Symbol	SETPEND							
Read/Write	R/W							
After reset	Undefined							
Function	Interrupt number 7 [Write] 1: Pend [Read] 0: Not pending 1: Pending	Interrupt number 6 [Write] 1: Pend [Read] 0: Not pending 1: Pending	Interrupt number 5 [Write] 1: Pend [Read] 0: Not pending 1: Pending	Interrupt number 4 [Write] 1: Pend [Read] 0: Not pending 1: Pending	Interrupt number 3 [Write] 1: Pend [Read] 0: Not pending 1: Pending	Interrupt number 2 [Write] 1: Pend [Read] 0: Not pending 1: Pending	Interrupt number 1 [Write] 1: Pend [Read] 0: Not pending 1: Pending	Interrupt number 0 [Write] 1: Pend [Read] 0: Not pending 1: Pending
	15	14	13	12	11	10	9	8
bit Symbol	SETPEND							
Read/Write	R/W							
After reset	Undefined							
Function	Interrupt number 15 [Write] 1: Pend [Read] 0: Not pending 1: Pending	Interrupt number 14 [Write] 1: Pend [Read] 0: Not pending 1: Pending	Interrupt number 13 [Write] 1: Pend [Read] 0: Not pending 1: Pending	Interrupt number 12 [Write] 1: Pend [Read] 0: Not pending 1: Pending	Interrupt number 11 [Write] 1: Pend [Read] 0: Not pending 1: Pending	Interrupt number 10 [Write] 1: Pend [Read] 0: Not pending 1: Pending	Interrupt number 9 [Write] 1: Pend [Read] 0: Not pending 1: Pending	Interrupt number 8 [Write] 1: Pend [Read] 0: Not pending 1: Pending
	23	22	21	20	19	18	17	16
bit Symbol	SETPEND							
Read/Write	R/W							
After reset	Undefined							
Function	Interrupt number 23 [Write] 1: Pend [Read] 0: Not pending 1: Pending	Interrupt number 22 [Write] 1: Pend [Read] 0: Not pending 1: Pending	Interrupt number 21 [Write] 1: Pend [Read] 0: Not pending 1: Pending	Interrupt number 20 [Write] 1: Pend [Read] 0: Not pending 1: Pending	Interrupt number 19 [Write] 1: Pend [Read] 0: Not pending 1: Pending	Interrupt number 18 [Write] 1: Pend [Read] 0: Not pending 1: Pending	Interrupt number 17 [Write] 1: Pend [Read] 0: Not pending 1: Pending	Interrupt number 16 [Write] 1: Pend [Read] 0: Not pending 1: Pending
	31	30	29	28	27	26	25	24
bit Symbol	SETPEND							
Read/Write	R/W							
After reset	Undefined							
Function	Interrupt number 31 [Write] 1: Pend [Read] 0: Not pending 1: Pending	Interrupt number 30 [Write] 1: Pend [Read] 0: Not pending 1: Pending	Interrupt number 29 [Write] 1: Pend [Read] 0: Not pending 1: Pending	Interrupt number 28 [Write] 1: Pend [Read] 0: Not pending 1: Pending	Interrupt number 27 [Write] 1: Pend [Read] 0: Not pending 1: Pending	Interrupt number 26 [Write] 1: Pend [Read] 0: Not pending 1: Pending	Interrupt number 25 [Write] 1: Pend [Read] 0: Not pending 1: Pending	Interrupt number 24 [Write] 1: Pend [Read] 0: Not pending 1: Pending

<bit31:0> <SETPEND> Use these bits to force interrupts into the pending state or determine which interrupts are currently pending.

Writing “1” to a bit in this register pends the corresponding interrupt. However, writing “1” has no effect on an interrupt that is already pending or is disabled. Writing “0” has no effect.

Reading a bit in this register returns the current state of the corresponding interrupt as shown below.

0 = Not pending

1 = Pending

Each bit in this register can be cleared by writing “1” to the corresponding bit in the Interrupt Clear-Pending Register.

<p><b>(Note) For descriptions of interrupts and interrupt numbers, see Section 8.5.1.4 List of Interrupt Sources.</b></p>
---

8.6.2.10 Interrupt Set-Pending Register 2

	7	6	5	4	3	2	1	0
bit Symbol	SETPEND							
Read/Write	R/W							
After reset	Undefined							
Function	Interrupt number 39 [Write] 1: Pend [Read] 0: Not pending 1: Pending	Interrupt number 38 [Write] 1: Pend [Read] 0: Not pending 1: Pending	Interrupt number 37 [Write] 1: Pend [Read] 0: Not pending 1: Pending	Interrupt number 36 [Write] 1: Pend [Read] 0: Not pending 1: Pending	Interrupt number 35 [Write] 1: Pend [Read] 0: Not pending 1: Pending	Interrupt number 34 [Write] 1: Pend [Read] 0: Not pending 1: Pending	Interrupt number 33 [Write] 1: Pend [Read] 0: Not pending 1: Pending	Interrupt number 32 [Write] 1: Pend [Read] 0: Not pending 1: Pending
	15	14	13	12	11	10	9	8
bit Symbol	SETPEND							
Read/Write	R/W							
After reset	Undefined							
Function	Interrupt number 47 [Write] 1: Pend [Read] 0: Not pending 1: Pending	Interrupt number 46 [Write] 1: Pend [Read] 0: Not pending 1: Pending	Interrupt number 45 [Write] 1: Pend [Read] 0: Not pending 1: Pending	Interrupt number 44 [Write] 1: Pend [Read] 0: Not pending 1: Pending	Interrupt number 43 [Write] 1: Pend [Read] 0: Not pending 1: Pending	Interrupt number 42 [Write] 1: Pend [Read] 0: Not pending 1: Pending	Interrupt number 41 [Write] 1: Pend [Read] 0: Not pending 1: Pending	Interrupt number 40 [Write] 1: Pend [Read] 0: Not pending 1: Pending
	23	22	21	20	19	18	17	16
bit Symbol							SETPEND	
Read/Write	R						R/W	
After reset	0						Undefined	
Function	"0" is read.						Interrupt number 49 [Write] 1: Pend [Read] 0: Not pending 1: Pending	Interrupt number 48 [Write] 1: Pend [Read] 0: Not pending 1: Pending
	31	30	29	28	27	26	25	24
bit Symbol								
Read/Write	R							
After reset	0							
Function	"0" is read.							

<bit17:0> <SETPEND> Use these bits to force interrupts into the pending state or determine which interrupts are currently pending.

Writing “1” to a bit in this register pends the corresponding interrupt. However, writing “1” has no effect on an interrupt that is already pending or is disabled. Writing “0” has no effect.

Reading a bit in this register returns the current state of the corresponding interrupt as shown below.

0 = Not pending

1 = Pending

Each bit in this register can be cleared by writing “1” to the corresponding bit in the Interrupt Clear-Pending Register.

<p><b>(Note) For descriptions of interrupts and interrupt numbers, see Section 8.5.1.4 List of Interrupt Sources.</b></p>
---

8.6.2.11 Interrupt Clear-Pending Register 1

	7	6	5	4	3	2	1	0
bit Symbol	CLRPEND							
Read/Write	R/W							
After reset	Undefined							
Function	Interrupt number 7 [Write] 1: Clear pending interrupt [Read] 0: Not pending 1: Pending	Interrupt number 6 [Write] 1: Clear pending interrupt [Read] 0: Not pending 1: Pending	Interrupt number 5 [Write] 1: Clear pending interrupt [Read] 0: Not pending 1: Pending	Interrupt number 4 [Write] 1: Clear pending interrupt [Read] 0: Not pending 1: Pending	Interrupt number 3 [Write] 1: Clear pending interrupt [Read] 0: Not pending 1: Pending	Interrupt number 2 [Write] 1: Clear pending interrupt [Read] 0: Not pending 1: Pending	Interrupt number 1 [Write] 1: Clear pending interrupt [Read] 0: Not pending 1: Pending	Interrupt number 0 [Write] 1: Clear pending interrupt [Read] 0: Not pending 1: Pending
	15	14	13	12	11	10	9	8
bit Symbol	CLRPEND							
Read/Write	R/W							
After reset	Undefined							
Function	Interrupt number 15 [Write] 1: Clear pending interrupt [Read] 0: Not pending 1: Pending	Interrupt number 14 [Write] 1: Clear pending interrupt [Read] 0: Not pending 1: Pending	Interrupt number 13 [Write] 1: Clear pending interrupt [Read] 0: Not pending 1: Pending	Interrupt number 12 [Write] 1: Clear pending interrupt [Read] 0: Not pending 1: Pending	Interrupt number 11 [Write] 1: Clear pending interrupt [Read] 0: Not pending 1: Pending	Interrupt number 10 [Write] 1: Clear pending interrupt [Read] 0: Not pending 1: Pending	Interrupt number 9 [Write] 1: Clear pending interrupt [Read] 0: Not pending 1: Pending	Interrupt number 8 [Write] 1: Clear pending interrupt [Read] 0: Not pending 1: Pending
	23	22	21	20	19	18	17	16
bit Symbol	CLRPEND							
Read/Write	R/W							
After reset	Undefined							
Function	Interrupt number 23 [Write] 1: Clear pending interrupt [Read] 0: Not pending 1: Pending	Interrupt number 22 [Write] 1: Clear pending interrupt [Read] 0: Not pending 1: Pending	Interrupt number 21 [Write] 1: Clear pending interrupt [Read] 0: Not pending 1: Pending	Interrupt number 20 [Write] 1: Clear pending interrupt [Read] 0: Not pending 1: Pending	Interrupt number 19 [Write] 1: Clear pending interrupt [Read] 0: Not pending 1: Pending	Interrupt number 18 [Write] 1: Clear pending interrupt [Read] 0: Not pending 1: Pending	Interrupt number 17 [Write] 1: Clear pending interrupt [Read] 0: Not pending 1: Pending	Interrupt number 16 [Write] 1: Clear pending interrupt [Read] 0: Not pending 1: Pending
	31	30	29	28	27	26	25	24
bit Symbol	CLRPEND							
Read/Write	R/W							
After reset	Undefined							
Function	Interrupt number 31 [Write] 1: Clear pending interrupt [Read] 0: Not pending 1: Pending	Interrupt number 30 [Write] 1: Clear pending interrupt [Read] 0: Not pending 1: Pending	Interrupt number 29 [Write] 1: Clear pending interrupt [Read] 0: Not pending 1: Pending	Interrupt number 28 [Write] 1: Clear pending interrupt [Read] 0: Not pending 1: Pending	Interrupt number 27 [Write] 1: Clear pending interrupt [Read] 0: Not pending 1: Pending	Interrupt number 26 [Write] 1: Clear pending interrupt [Read] 0: Not pending 1: Pending	Interrupt number 25 [Write] 1: Clear pending interrupt [Read] 0: Not pending 1: Pending	Interrupt number 24 [Write] 1: Clear pending interrupt [Read] 0: Not pending 1: Pending

<bit31:0> <CLRPEND> Use these bits to clear pending interrupts or determine which interrupts are currently pending.

Writing “1” to a bit in this register clears the corresponding pending interrupt. However, writing “1” has no effect on an interrupt that is already being serviced. Writing “0” has no effect.

Reading a bit in this register returns the current state of the corresponding interrupt as shown below.

0 = Not pending  
1 = Pending

<b>(Note) For descriptions of interrupts and interrupt numbers, see Section 8.5.1.4 List of Interrupt Sources.</b>
--

8.6.2.12 Interrupt Clear-Pending Register 2

	7	6	5	4	3	2	1	0
bit Symbol	CLRPEND							
Read/Write	R/W							
After reset	Undefined							
Function	Interrupt number 39 [Write] 1: Clear pending interrupt [Read] 0: Not pending 1: Pending	Interrupt number 38 [Write] 1: Clear pending interrupt [Read] 0: Not pending 1: Pending	Interrupt number 37 [Write] 1: Clear pending interrupt [Read] 0: Not pending 1: Pending	Interrupt number 36 [Write] 1: Clear pending interrupt [Read] 0: Not pending 1: Pending	Interrupt number 35 [Write] 1: Clear pending interrupt [Read] 0: Not pending 1: Pending	Interrupt number 34 [Write] 1: Clear pending interrupt [Read] 0: Not pending 1: Pending	Interrupt number 33 [Write] 1: Clear pending interrupt [Read] 0: Not pending 1: Pending	Interrupt number 32 [Write] 1: Clear pending interrupt [Read] 0: Not pending 1: Pending
	15	14	13	12	11	10	9	8
bit Symbol	CLRPEND							
Read/Write	R/W							
After reset	Undefined							
Function	Interrupt number 47 [Write] 1: Clear pending interrupt [Read] 0: Not pending 1: Pending	Interrupt number 46 [Write] 1: Clear pending interrupt [Read] 0: Not pending 1: Pending	Interrupt number 45 [Write] 1: Clear pending interrupt [Read] 0: Not pending 1: Pending	Interrupt number 44 [Write] 1: Clear pending interrupt [Read] 0: Not pending 1: Pending	Interrupt number 43 [Write] 1: Clear pending interrupt [Read] 0: Not pending 1: Pending	Interrupt number 42 [Write] 1: Clear pending interrupt [Read] 0: Not pending 1: Pending	Interrupt number 41 [Write] 1: Clear pending interrupt [Read] 0: Not pending 1: Pending	Interrupt number 40 [Write] 1: Clear pending interrupt [Read] 0: Not pending 1: Pending
	23	22	21	20	19	18	17	16
bit Symbol							CLRPEND	
Read/Write	R						R/W	
After reset	0						Undefined	
Function	"0" is read.						Interrupt number 49 [Write] 1: Clear pending interrupt [Read] 0: Not pending 1: Pending	Interrupt number 48 [Write] 1: Clear pending interrupt [Read] 0: Not pending 1: Pending
	31	30	29	28	27	26	25	24
bit Symbol								
Read/Write	R							
After reset	0							
Function	"0" is read.							

<bit17:0> <CLRPEND> Use these bits to clear pending interrupts or determine which interrupts are currently pending.

Writing "1" to a bit in this register clears the corresponding pending interrupt. However, writing "1" has no effect on an interrupt that is already being serviced. Writing "0" has no effect.

Reading a bit in this register returns the current state of the corresponding interrupt as shown below.

0 = Not pending

1 = Pending

<b>(Note)</b> For descriptions of interrupts and interrupt numbers, see Section 8.5.1.4 List of Interrupt Sources.
--

**8.6.2.13 Interrupt Priority Registers**

Each interrupt is provided with eight bits of an Interrupt Priority Register.

The following shows the addresses of the Interrupt Priority Registers corresponding to interrupt numbers.

	31	24	23	16	15	8	7	0
0xE000_E400	PRI_3			PRI_2		PRI_1		PRI_0
0xE000_E404	PRI_7			PRI_6		PRI_5		PRI_4
0xE000_E408	PRI_11			PRI_10		PRI_9		PRI_8
0xE000_E40C	PRI_15			PRI_14		PRI_13		PRI_12
0xE000_E410	PRI_19			PRI_18		PRI_17		PRI_16
0xE000_E414	PRI_23			PRI_22		PRI_21		PRI_20
0xE000_E418	PRI_27			PRI_26		PRI_25		PRI_24
0xE000_E41C	PRI_31			PRI_30		PRI_29		PRI_28
0xE000_E420	PRI_35			PRI_34		PRI_33		PRI_32
0xE000_E424	PRI_39			PRI_38		PRI_37		PRI_36
0xE000_E428	PRI_43			PRI_42		PRI_41		PRI_40
0xE000_E42C	PRI_47			PRI_46		PRI_45		PRI_44
0xE000_E430	-			-		PRI_49		PRI_48

The number of bits to be used for assigning a priority varies with each product. This product uses three bits for assigning a priority.

The following shows the fields of the Interrupt Priority Registers for interrupt numbers 0 to 3. The Interrupt Priority Registers for all other interrupt numbers have the identical fields. Unused bits return “0” when read, and writing to unused bits has no effect.

	7	6	5	4	3	2	1	0
bit Symbol	PRI_0							
Read/Write	R/W			R				
After reset	0			0				
Function	Priority of interrupt number 0			“0” is read.				
	15	14	13	12	11	10	9	8
bit Symbol	PRI_1							
Read/Write	R/W			R				
After reset	0			0				
Function	Priority of interrupt number 1			“0” is read.				
	23	22	21	20	19	18	17	16
bit Symbol	PRI_2							
Read/Write	R/W			R				
After reset	0			0				
Function	Priority of interrupt number 2			“0” is read.				
	31	30	29	28	27	26	25	24
bit Symbol	PRI_3							
Read/Write	R/W			R				
After reset	0			0				
Function	Priority of interrupt number 3			“0” is read.				

<bit7:5>	<PRI_0>	Priority of interrupt number 0
<bit15:13>	<PRI_1>	Priority of interrupt number 1
<bit23:21>	<PRI_2>	Priority of interrupt number 2
<bit31:29>	<PRI_3>	Priority of interrupt number 3

8.6.2.14 Vector Table Offset Register

	7	6	5	4	3	2	1	0	
bit Symbol	TBLOFF								
Read/Write	R/W	R							
After reset	0	0							
Function	Offset value	"0" is read.							
	15	14	13	12	11	10	9	8	
bit Symbol	TBLOFF								
Read/Write	R/W								
After reset	0								
Function	Offset value								
	23	22	21	20	19	18	17	16	
bit Symbol	TBLOFF								
Read/Write	R/W								
After reset	0								
Function	Offset value								
	31	30	29	28	27	26	25	24	
bit Symbol			TBLBASE	TBLOFF					
Read/Write	R		R/W	R/W					
After reset	0		0	0					
Function	"0" is read.		Table base	Offset value					

- <bit28:7> <TBLOFF> Set the offset value from the top of the space specified in TBLBASE. The offset must be aligned based on the number of exceptions in the table. This means that the minimum alignment is 32 words that you can use for up to 16 interrupts. For more interrupts, you must adjust the alignment by rounding up to the next power of two.
- <bit29> <TBLBASE> The vector table is in:  
 0 = Code space  
 1 = SRAM space

### 8.6.2.15 System Handler Priority Registers

Each exception is provided with eight bits of a System Handler Priority Register.

The following shows the addresses of the System Handler Priority Registers corresponding to each exception.

	31	24	23	16	15	8	7	0
0xE000_ED18	PRI_7			PRI_6 (Usage Fault)		PRI_5 (Bus Fault)		PRI_4 (Memory Management)
0xE000_ED1C	PRI_11 (SVCall)			PRI_10		PRI_9		PRI_8
0xE000_ED20	PRI_15 (SysTick)			PRI_14 (PendSV)		PRI_13		PRI_12 (Debug Monitor)

The number of bits to be used for assigning a priority varies with each product. This product uses three bits for assigning a priority.

The following shows the fields of the System Handler Priority Registers for Memory Management, Bus Fault and Usage Fault. The System Handler Priority Registers for all other exceptions have the identical fields. Unused bits return “0” when read, and writing to unused bits has no effect.

	7	6	5	4	3	2	1	0
bit Symbol	PRI_4							
Read/Write	R/W			R				
After reset	0			0				
Function	Priority of Memory Management			“0” is read.				
	15	14	13	12	11	10	9	8
bit Symbol	PRI_5							
Read/Write	R/W			R				
After reset	0			0				
Function	Priority of Bus Fault			“0” is read.				
	23	22	21	20	19	18	17	16
bit Symbol	PRI_6							
Read/Write	R/W			R				
After reset	0			0				
Function	Priority of Usage Fault			“0” is read.				
	31	30	29	28	27	26	25	24
bit Symbol	PRI_7							
Read/Write	R/W			R				
After reset	0			0				
Function	Reserved			“0” is read.				

8.6.2.16 System Handler Control and State Register

	7	6	5	4	3	2	1	0
bit Symbol	SVCALL ACT				USGFAU LT ACT		BUSFAU LT ACT	MEMFAU LT ACT
Read/Write	R/W	R			R/W	R	R/W	R/W
After reset	0	0			0	0	0	0
Function	SVCall 0: Inactive 1: Active	"0" is read.			Usage fault 0: Inactive 1: Active	"0" is read.	Bus fault 0: Inactive 1: Active	Memory Management 0: Inactive 1: Active
	15	14	13	12	11	10	9	8
bit Symbol	SVCALL PENDED	BUSFAU LT PENDED	MEMFAU LT PENDED	USGFAU LT PENDED	SYSTICK ACT	PENDSV ACT		MONITO R ACT
Read/Write	R/W	R/W	R/W	R/W	R/W	R/W	R	R/W
After reset	0	0	0	0	0	0	0	0
Function	SVCall 0: Not pending 1: Pended	Bus Fault 0: Not pending 1: Pended	Memory Management 0: Not pending 1: Pended	Usage Fault 0: Not pending 1: Pended	SysTick 0: Inactive 1: Active	PendSV 0: Inactive 1: Active	"0" is read.	Debug Monitor 0: Inactive 1: Active
	23	22	21	20	19	18	17	16
bit Symbol						USGFAU LT ENA	BUSFAU LT ENA	MEMFAU LT ENA
Read/Write	R					R/W	R/W	R/W
After reset	0					0	0	0
Function	"0" is read.					Usage Fault 0: Disable 1: Enable	Bus Fault 0: Disable 1: Enable	Memory Management 0: Disable 1: Enable
	31	30	29	28	27	26	25	24
bit Symbol								
Read/Write	R							
After reset	0							
Function	"0" is read.							

---

<bit0>	<MEMFAULTACT>	Reads as “1” if Memory Management is active.
<bit1>	<BUSFAULTACT>	Reads as “1” if Bus Fault is active.
<bit3>	<USGFALACT>	Reads as “1” if Usage Fault is active.
<bit7>	<SVCALLACT>	Reads as “1” if SVCAll is active.
<bit8>	<MONITORACT>	Reads as “1” if Debug Monitor is active.
<bit10>	<PENDSVACT>	Reads as “1” if PendSV is active.
<bit11>	<SYSTICKACT>	Reads as “1” if SysTick is active.
<bit12>	<USGFAULTPENDEDED>	Reads as “1” if Usage Fault is pending.
<bit13>	<MEMFAULTPENDEDED>	Reads as “1” if Memory Management is pending.
<bit14>	<BUSFAULTPENDEDED>	Reads as “1” if Bus Fault is pending.
<bit15>	<SVCALLPENDEDED>	Reads as “1” if SVCAll is pending.
<bit16>	<MEMFAULTENA>	Set to “0” to disable or “1” to enable Memory Management.
<bit17>	<BUSFAULTENA>	Set to “0” to disable or “1” to enable Bus Fault.
<bit18>	<USGFAULTENA>	Set to “0” to disable or “1” to enable Usage Fault.

**(Note)** You must clear or set the active bits with extreme caution because clearing and setting these bits does not repair stack contents.

## 8.6.3 NVIC Registers

## 8.6.3.1 CG Interrupt Mode Control Register A

CGIMCGA		7	6	5	4	3	2	1	0
	bit Symbol		EMCG02	EMCG01	EMCG00	EMST01	EMST00		INT0EN
	Read/Write	R	R/W			R		R	R/W
	After reset	0	0	1	0	0	0	Undefined	0
	Function	"0" is read.	Active state setting of INT0 standby clear request. (101~111: setting prohibited) 000: "L" level 001: "H" level 010: Falling edge 011: Rising edge 100: Both edges			Active state of INT0 standby clear request 00: – 01: Rising edge 10: Falling edge 11: Both edges		"0" is read.	INT0 clear input 0: Disable 1: Enable
		15	14	13	12	11	10	9	8
bit Symbol		EMCG12	EMCG11	EMCG10	EMST11	EMST10		INT1EN	
Read/Write	R	R/W			R		R	R/W	
After reset	0	0	1	0	0	0	Undefined	0	
Function	"0" is read.	Active state setting of INT1 standby clear request. (101~111: setting prohibited) 000: "L" level 001: "H" level 010: Falling edge 011: Rising edge 100: Both edges			Active state of INT1 standby clear request 00: – 01: Rising edge 10: Falling edge 11: Both edges		"0" is read.	INT1 clear input 0: Disable 1: Enable	
		23	22	21	20	19	18	17	16
bit Symbol		EMCG22	EMCG21	EMCG20	EMST21	EMST20		INT2EN	
Read/Write	R	R/W			R		R	R/W	
After reset	0	0	1	0	0	0	Undefined	0	
Function	"0" is read.	Active state setting of INT2 standby clear request. (101~111: setting prohibited) 000: "L" level 001: "H" level 010: Falling edge 011: Rising edge 100: Both edges			Active state of INT2 standby clear request 00: – 01: Rising edge 10: Falling edge 11: Both edges		"0" is read.	INT2 clear input 0: Disable 1: Enable	
		31	30	29	28	27	26	25	24
bit Symbol		EMCG32	EMCG31	EMCG30	EMST31	EMST30		INT3EN	
Read/Write	R	R/W			R		R	R/W	
After reset	0	0	1	0	0	0	Undefined	0	
Function	"0" is read.	Active state setting of INT3 standby clear request. (101~111: setting prohibited) 000: "L" level 001: "H" level 010: Falling edge 011: Rising edge 100: Both edges			Active state of INT3 standby clear request 00: – 01: Rising edge 10: Falling edge 11: Both edges		"0" is read.	INT3 clear input 0: Disable 1: Enable	

(Note 1) <EMSTx> is effective only when <EMSTGx[2:0]> is set to "100" for both rising and falling edge. The active level used for the reset of standby can be checked by <EMSTx>. If interrupts are cleared with the CGICRCG register, <EMSTx> is also cleared.

(Note 2) Please specify the bit for the edge first and then specify the bit for the <INTxEN>. Setting them simultaneously is prohibited.

## 8.6.3.2 CG Interrupt Mode Control Register B

CGIMCGB		7	6	5	4	3	2	1	0
	bit Symbol		EMCG42	EMCG41	EMCG40	EMST41	EMST40		INT4EN
	Read/Write	R	R/W			R		R	R/W
	After reset	0	0	1	0	0	0	0	0
	Function	"0" is read.	Active state setting of INT4 standby clear request (101~111: setting prohibited) 000: "L" level 001: "H" level 010: Falling edge 011: Rising edge 100: Both edges			Active state of INT4 standby clear request 00: – 01: Rising edge 10: Falling edge 11: Both edges		"0" is read.	INT4 clear input 0: Disable 1: Enable
		15	14	13	12	11	10	9	8
bit Symbol		EMCG52	EMCG51	EMCG50	EMST51	EMST50		INT5EN	
Read/Write	R	R/W			R		R	R/W	
After reset	0	0	1	0	0	0	0	0	
Function	"0" is read.	Active state setting of INT5 standby clear request. (101~111: setting prohibited) 000: "L" level 001: "H" level 010: Falling edge 011: Rising edge 100: Both edges			Active state of INT5 standby clear request 00: – 01: Rising edge 10: Falling edge 11: Both edges		"0" is read.	INT5 clear input 0: Disable 1: Enable	
		23	22	21	20	19	18	17	16
bit Symbol		EMCG62	EMCG61	EMCG60	EMST61	EMST60		INT6EN	
Read/Write	R	R/W			R		R	R/W	
After reset	0	0	1	0	0	0	0	0	
Function	"0" is read.	Active state setting of INTCECRX standby clear request.  <b>Set it as shown below.</b> 011: Rising edge			Active state of INTCECRX standby clear request 00: – 01: Rising edge 10: Falling edge 11: Both edges		"0" is read.	INTCECRX clear input 0: Disable 1: Enable	
		31	30	29	28	27	26	25	24
bit Symbol		EMCG72	EMCG71	EMCG70	EMST71	EMST70		INT7EN	
Read/Write	R	R/W			R		R	R/W	
After reset	0	0	1	0	0	0	0	0	
Function	"0" is read.	Active state setting of INTRMCRX0 standby clear request.  <b>Set it as shown below.</b> 011: Rising edge			Active state of INTRMCRX0 standby clear request 00: – 01: Rising edge 10: Falling edge 11: Both edges		"0" is read.	INTRMCRX0 clear input 0: Disable 1: Enable	

**(Note 1)** Refer to EMSTxx bit to know the active condition which is used for clearing standby.

**(Note 2)** Please specify the bit for the edge first and then specify the bit for the <INTxEN>. Setting them simultaneously is prohibited.

8.6.3.3 CG Interrupt Mode Control Register C

CGIMCGC		7	6	5	4	3	2	1	0
	bit Symbol		EMCG82	EMCG81	EMCG80	EMST81	EMST80		INT8EN
	Read/Write	R	R/W			R		R	R/W
	After reset	0	0	1	0	0	0	0	0
Function	"0" is read.	Active state setting of INTRTC standby clear request.  <b>Set it as shown below.</b> 010: Falling edge			Active state of INTRTC standby clear request.  00: - 01: Rising edge 10: Falling edge 11: Both edges		"0" is read.	INTRTC clear input  0: Disable 1: Enable	
		15	14	13	12	11	10	9	8
bit Symbol		EMCG92	EMCG91	EMCG90	EMST91	EMST90		INT9EN	
Read/Write	R	R/W			R		R	R/W	
After reset	0	0	1	0	0	0	0	0	
Function	"0" is read.	Active state setting of INT6 standby clear request. (101~111: setting prohibited) 000: "L" level 001: "H" level 010: Falling edge 011: Rising edge 100: Both edges			Active state of INT6 standby clear request.  00: - 01: Rising edge 10: Falling edge 11: Both edges		"0" is read.	INT6 clear input  0: Disable 1: Enable	
		23	22	21	20	19	18	17	16
bit Symbol		EMCGA2	EMCGA1	EMCGA0	EMSTA1	EMSTA0		INTAEN	
Read/Write	R	R/W			R		R	R/W	
After reset	0	0	1	0	0	0	0	0	
Function	"0" is read.	Active state setting of INT7 standby clear request. (101~111: setting prohibited) 000: "L" level 001: "H" level 010: Falling edge 011: Rising edge 100: Both edges			Active state of INT7 standby clear request.  00: - 01: Rising edge 10: Falling edge 11: Both edges		"0" is read.	INT7 clear input  0: Disable 1: Enable	
		31	30	29	28	27	26	25	24
bit Symbol		EMCGB2	EMCGB1	EMCGB0	EMSTB1	EMSTB0		INTBEN	
Read/Write	R	R/W			R		R	R/W	
After reset	0	0	1	0	0	0	0	0	
Function	"0" is read.	Active state setting of INTRMCRX1 standby clear request.  <b>Set it as shown below.</b> 011: Rising edge			Active state of INTRMCRX1 standby clear request.  00: - 01: Rising edge 10: Falling edge 11: Both edges		"0" is read.	INTRMCRX1 clear input  0: Disable 1: Enable	

- (Note 1) Refer to EMSTxx bit to know the active condition which is used for clearing standby.
- (Note 2) Please specify the bit for the edge first and then specify the bit for the <INTxEN>. Setting them simultaneously is prohibited.

## 8.6.3.4 CG Interrupt Mode Control Register D

CGIMCGD		7	6	5	4	3	2	1	0
	bit Symbol		EMCGC2	EMCGC1	EMCGC0	EMSTC1	EMSTC0		INTCEN
	Read/Write	R	R/W			R		R	R/W
	After reset	0	0	1	0	0	0	0	0
	Function	"0" is read.	Active state setting of INTCECTX standby clear request.  <b>Set it as shown below.</b> 010: Rising edge			Active state of INTCECTX standby clear request.  00: - 01: Rising edge 10: Falling edge 11: Both edges		"0" is read.	INTCECTX Clear input  0: Disable 1: Enable
		15	14	13	12	11	10	9	8
bit Symbol									
Read/Write	R	R/W			R				R/W
After reset	0	0	1	0	0	0	0	0	0
Function	"0" is read.	Write any value.			"0" is read.				Write "0".
		23	22	21	20	19	18	17	16
bit Symbol									
Read/Write	R	R/W			R				R/W
After reset	0	0	1	0	0	0	0	0	0
Function	"0" is read.	Write any value.			"0" is read.				Write "0".
		31	30	29	28	27	26	25	24
bit Symbol									
Read/Write	R	R/W			R				R/W
After reset	0	0	1	0	0	0	0	0	0
Function	"0" is read.	Write any value.			"0" is read.				Write "0".

**(Note 1)** Refer to EMSTxx bit to know the active condition which is used for clearing standby.

**(Note 2)** Please specify the bit for the edge first and then specify the bit for the <INTxEN>. Setting them simultaneously is prohibited.

8.6.3.5 CG Interrupt Request Clear Register

CGICRCG		7	6	5	4	3	2	1	0
	bit Symbol				ICRCG4	ICRCG3	ICRCG2	ICRCG1	ICRCG0
	Read/Write	R			W				
	After reset	0			0	0	0	0	0
	Function	"0" is read.			Clear interrupt requests. 0_000: INT0      0_0100: INT4      0_1000: INTRTC 0_0001: INT1      0_0101: INT5      0_1001: INT6 0_0010: INT2      0_0110:              0_1010: INT7 0_0011: INT3      INTCECRX              0_1011: 0_0111:              INTRMCRX1 IINTRMCRX0          0_1100: INTCECTX * 0_1101~1_1111: setting prohibited * "0" is read.				
	15	14	13	12	11	10	9	8	
bit Symbol									
Read/Write	R								
After reset	0								
Function	"0" is read.								
	23	22	21	20	19	18	17	16	
bit Symbol									
Read/Write									
After reset									
Function	"0" is read.								
	31	30	29	28	27	26	25	24	
bit Symbol									
Read/Write	R								
After reset	0								
Function	"0" is read.								

8.6.3.6 NMI Flag Register

CGNMIFLG

	7	6	5	4	3	2	1	0
bit Symbol							NMIFLG1	NMIFLG0
Read/Write	R							
After reset	0	0	0	0	0	0	0	0
Function	"0" is read.						NMI source generation flag	NMI source generation flag
							0: not applicable 1: generated from NMI pin	0: not applicable 1: generated from WDT
	15	14	13	12	11	10	9	8
bit Symbol								
Read/Write	R							
After reset	0	0	0	0	0	0	0	0
Function	"0" is read.							
	23	22	21	20	19	18	17	16
bit Symbol								
Read/Write	R							
After reset	0	0	0	0	0	0	0	0
Function	"0" is read.							
	31	30	29	28	27	26	25	24
bit Symbol								
Read/Write	R							
After reset	0	0	0	0	0	0	0	0
Function	"0" is read.							

**(Note)** <NMIFLG[1:0]> are cleared to "0" when they are read.

8.6.3.7 Reset Flag Register

CGRSTFLG		7	6	5	4	3	2	1	0
	bit Symbol				SYSRSTF		WDRSTF	PINRSTF	PONRSTF
	Read/Write	R			R/W	R/W	R/W	R/W	R/W
	After pin reset	0	0	0	0	0	0	1	1/0
	Function	"0" is read.			Debug reset flag 0: "0" is written 1: Reset from SYSTR EQ (Note 2)	Write "0".	WDT reset flag 0: "0" is written 1: Reset from WDT	RESET pin flag 0: "0" is written 1: Reset from RESET pin	Power-on flag 0: "0" is written 1: Reset from power-on reset
		15	14	13	12	11	10	9	8
bit Symbol									
Read/Write	R								
After pin reset	0	0	0	0	0	0	0	0	0
Function	"0" is read.								
		23	22	21	20	19	18	17	16
bit Symbol									
Read/Write	R								
After pin reset	0	0	0	0	0	0	0	0	0
Function	"0" is read.								
		31	30	29	28	27	26	25	24
bit Symbol									
Read/Write	R								
After pin reset	0	0	0	0	0	0	0	0	0
Function	"0" is read.								

- (Note 1) The TMPM330 has power-on reset circuit and this register is initialized only by power-on reset. Therefore, "1" is set to the <PONRSTF> bit in initial reset state right after power-on. Note that this bit is not set by the second and subsequent resets and this register is not cleared automatically. Write "0" to clear the register.
- (Note 2) This flag indicates a reset generated by the SYSRESETREQ bit of the Application Interrupt and Reset Control Register of the CPU's NVIC.

## 9 Input/Output Ports

### 9.1 Port registers

- Px** : **Port register**  
To read/ write port data.
- PxCR** : **Control register**  
To control input/output  
\* Need to enable the input with PxIE register even when input is set.
- PxFRn** : **Function register**  
To set functions. An assigned function can be activated by setting “1”.
- PxOD** : **Open drain control register**  
To switch the input of a register that can be set as programmable open drain.
- PxPUP** : **Pull up control register**  
To control program pull ups.
- PxPDN** : **Pull down control register**  
To control programmable pull downs.
- PxIE** : **Input control enable register**  
To control inputs. “0” is set as default to avoid through current. This setting prohibits inputs.

## 9.2 Port Functions

### 9.2.1 Port States in STOP Mode

Input and output in STOP mode are enabled/disabled by the CGSTBYCR<DRVE> bit in the Standby Control Register.

If PxIE or PxCR is enabled with <DRVE>=1, input or output is enabled respectively in STOP mode. If <DRVE>=0, both input and output are disabled in STOP mode except for some ports even if PxIE and PxCR are enabled.

The differences are summarized in the table shown below.

Port	I/O	<DRVE>=0	<DRVE>=1
PA0, PB0 [When used for debug (PxFR<n>=1) and output is enabled (PxCR<n>=1)]	Input	×	Depends on PxIE<n>.
	Output	Enabled when data is valid. Disabled when data is invalid.	Enabled when data is valid. Disabled when data is invalid.
PF7, PG3, PJ0-3, PJ6, PJ7 [When used for interrupt (PxFR<n>=1) and input is enabled (PxIE<n>=1)]	Input	○	○
	Output	×	Depends on PxCR<n>.
Other ports	Input	×	Depends on PxIE<n>.
	Output	×	Depends on PxCR<n>.

○: Input or output enabled

×: Input or output disabled

### 9.2.2 Precaution for Mode Transition

If PA1 is configured as a debug function pin, it prevents the low power consumption mode from being fully effective. Configure PA1 to function as a general-purpose port if the debug function is not used.

### 9.2.3 Port A (PA0~PA7)

The port A is a general-purpose, 8-bit input/output port. For this port, inputs and outputs can be specified in units of bits. Besides the general-purpose input/output function, the port A performs the debug communication function and the debug trace output function.

Reset configures PA0 and PA1 as debug communication pins. PA0 is initialized as the TMS/SWDIO pin with input, output and pull-up enabled. PA1 is initialized as the TCK/SWCLK pin with input and pull-down enabled.

Other bits of the port A are initialized as general-purpose ports with input, output and pull-up disabled.

- (Note 1)** PA0 and PA1 are initialized as debug communication pins with input, output, pull-up and pull-down enabled.
- (Note 2)** If PA0 is configured as the TMS/SWDIO pin, output is enabled even in STOP mode regardless of the CGSTBYCR<DRVE> bit setting.
- (Note 3)** If PA1 is configured as a debug communication pin, it prevents the low power consumption mode from being fully effective. Configure PA1 to function as a general-purpose port if the debug function is not used.

Port A Circuit Type

	7	6	5	4	3	2	1	0
Type	T1	T9	T9	T9	T9	T9	T6	T12

Port A register

PA  
(0x4000\_0000)

	7	6	5	4	3	2	1	0
Bit Symbol	PA7	PA6	PA5	PA4	PA3	PA2	PA1	PA0
Read/Write	R/W							
After reset	"0"							

Port A control register

PACR  
(0x4000\_0004)

	7	6	5	4	3	2	1	0
Bit Symbol	PA7C	PA6C	PA5C	PA4C	PA3C	PA2C	PA1C	PA0C
Read/Write	R/W							
After reset	0	0	0	0	0	0	0	1
Function	0: Output disabled 1: Output enabled							

Port A function register 1

PAFR1  
(0x4000\_0008)

	7	6	5	4	3	2	1	0
Bit Symbol	—	PA6F1	PA5F1	PA4F1	PA3F1	PA2F1	PA1F1	PA0F1
Read/Write	R	R/W						
After reset	0	0	0	0	0	0	1	1
Function	"0" is read.	0:PORT 1: TRACE DATA3	0:PORT 1: TRACE DATA2	0:PORT 1: TRACE DATA1	0:PORT 1TRACE DATA0	0:PORT 1: TRACE CLK	0:PORT 1: TCK/ SWCLK	0:PORT 1: TMS/ SWDIO

Port A pull-up control register

PAPUP  
(0x4000\_002C)

	7	6	5	4	3	2	1	0	
Bit Symbol	PA7UP	PA6UP	PA5UP	PA4UP	PA3UP	PA2UP	—	PA0UP	
Read/Write	R/W							R	R/W
After reset	0	0	0	0	0	0	0	1	
Function	Pull-up 0:off 1:on	Pull-up 0:off 1:on	Pull-up 0:off 1:on	Pull-up 0:off 1:on	Pull-up 0:off 1:on	Pull-up 0:off 1:on	"0" is read.	Pull-up 0:off 1:on	

Port A pull-down control register

PAPDN  
(0x4000\_0030)

	7	6	5	4	3	2	1	0	
Bit Symbol	—	—	—	—	—	—	PA1DN	—	
Read/Write	R							R/W	R
After reset	0	0	0	0	0	0	1	0	
Function	"0" is read.							Pull-up 0:off 1:on	"0" is read.

Port A input enable control register

PAIE  
(0x4000\_0038)

	7	6	5	4	3	2	1	0
Bit Symbol	PA7IE	PA6IE	PA5IE	PA4IE	PA3IE	PA2IE	PA1IE	PA0IE
Read/Write	R/W							
After reset	0	0	0	0	0	0	1	1
Function	Input 0:disabled 1:enabled	Input 0:disabled 1:enabled	Input 0:disabled 1:enabled	Input 0:disabled 1:enabled	Input 0:disabled 1:enabled	Input 0:disabled 1:enabled	Input 0:disabled 1:enabled	Input 0:disabled 1:enabled

### 9.2.4 Port B (PB0~PB7)

The port B is a general-purpose, 8-bit input/output port. For this port, inputs and outputs can be specified in units of bits. Besides the general-purpose input/output function, the port B performs the debug communication function.

Reset configures PB0, PB1 and PB2 as debug communication pins. PB0 is initialized as the TDO/SWV pin with output enabled. PB1 is initialized as the TDI pin with input and pull-up enabled. PB2 is initialized as the TRST pin with input and pull-up enabled.

Other bits of the port B are initialized as general-purpose ports with input, output and pull-up disabled.

- |   |
|---|
| <p><b>(Note 1)</b> PB0, PB1 and PB2 are initialized as debug communication pins with input, output and pull-up enabled.</p> <p><b>(Note 2)</b> If PB0 is configured as the TDO/SWV pin, output is enabled even in STOP mode regardless of the CGSTBYCR&lt;DRVE&gt; bit setting.</p> |
|---|

Port B Circuit Type

	7	6	5	4	3	2	1	0
Type	T1	T1	T1	T1	T1	T2	T2	T11

Port B register

PB  
(0x4000\_0040)

	7	6	5	4	3	2	1	0
Bit Symbol	PB7	PB6	PB5	PB4	PB3	PB2	PB1	PB0
Read/Write	R/W							
After reset	"0"							

Port B control register

PBCR  
(0x4000\_0044)

	7	6	5	4	3	2	1	0
Bit Symbol	PB7C	PB6C	PB5C	PB4C	PB3C	PB2C	PB1C	PB0C
Read/Write	R/W							
After reset	0	0	0	0	0	0	0	1
Function	0: Output disabled 1: Output enabled							

Port B function register 1

PBFR1  
(0x4000\_0048)

	7	6	5	4	3	2	1	0
Bit Symbol	—	—	—	—	—	PB2F1	PB1F1	PB0F1
Read/Write	R					R/W		
After reset	0					1	1	1
Function	"0" is read.					0:PORT 1: TRST	0:PORT 1: TDI	0:PORT 1: TDO/SWV

Port B pull-up control register

PBPUP  
(0x4000\_006C)

	7	6	5	4	3	2	1	0
Bit Symbol	PB7UP	PB6UP	PB5UP	PB4UP	PB3UP	PB2UP	PB1UP	PB0UP
Read/Write	R/W							
After reset	0	0	0	0	0	1	1	0
Function	Pull-up 0:off 1:on	Pull-up 0:off 1:on	Pull-up 0:off 1:on	Pull-up 0:off 1:on	Pull-up 0:off 1:on	Pull-up 0:off 1:on	Pull-up 0:off 1:on	Pull-up 0:off 1:on

Port B input enable control register

PBIE  
(0x4000\_0078)

	7	6	5	4	3	2	1	0
Bit Symbol	PB7IE	PB6IE	PB5IE	PB4IE	PB3IE	PB2IE	PB1IE	PB0IE
Read/Write	R/W							
After reset	0	0	0	0	0	1	1	0
Function	Input 0:disabled 1:enabled	Input 0:disabled 1:enabled	Input 0:disabled 1:enabled	Input 0:disabled 1:enabled	Input 0:disabled 1:enabled	Input 0:disabled 1:enabled	Input 0:disabled 1:enabled	Input 0:disabled 1:enabled

9.2.5 Port C (PC0~PC3)

The port C is a 4-bit input port. Besides the general-purpose input function, the port C functions as analog input pins of the A/D converter.

Reset initializes all bits of the port C as general-purpose input ports with input and pull-up disabled.

Set the input enable control register when you use the port C as input ports. The setting is not required when you use it as analog input pins of the A/D converter.

**(Note) Unless you use all the bits of port C and port D as analog input pins, conversion accuracy may be reduced. Be sure to verify that this causes no problem on your system.**

Port C Circuit Type

	7	6	5	4	3	2	1	0
Type	—	—	—	—	T17	T17	T17	T17

Port C register

	7	6	5	4	3	2	1	0
Bit Symbol	—	—	—	—	PC3	PC2	PC1	PC0
Read/Write	R				R			
After reset	"0" is read.				"1"			

PC  
(0x4000\_0080)

Port C pull-up control register

	7	6	5	4	3	2	1	0
Bit Symbol	—	—	—	—	PC3UP	PC2UP	PC1UP	PC0UP
Read/Write	R				R/W			
After reset	0				0	0	0	0
Function	"0" is read.				Pull-up 0:off 1:on	Pull-up 0:off 1:on	Pull-up 0:off 1:on	Pull-up 0:off 1:on

PCPUP  
(0x4000\_00AC)

Port C input enable control register

	7	6	5	4	3	2	1	0
Bit Symbol	—	—	—	—	PC3IE	PC2IE	PC1IE	PC0IE
Read/Write	R				R/W			
After reset	0				0	0	0	0
Function	"0" is read.				Input 0:disabled 1:enabled	Input 0:disabled 1:enabled	Input 0:disabled 1:enabled	Input 0:disabled 1:enabled

PCIE  
(0x4000\_00B8)

9.2.6 Port D (PD0~PD7)

The port D is an 8-bit input port. Besides the general-purpose input function, the port D receives an analog input of the A/D converter and a 16-bit timer input.

Reset initializes all bits of the port D as general-purpose input ports with input and pull-up disabled.

Set the input enable control register when you use the port D as input ports. Set the function register 1 and input enable control register when you use the port D as input pins of the 16-bit timer. No register setting is required when you use it as analog input pins of the A/D converter.

**(Note) Unless you use all the bits of port C and port D as analog input pins, conversion accuracy may be reduced. Be sure to verify that this causes no problem on your system.**

Port D Circuit Type

	7	6	5	4	3	2	1	0
Type	T17	T17	T17	T17	T18	T18	T18	T18

Port D register

	7	6	5	4	3	2	1	0
Bit Symbol	PD7	PD6	PD5	PD4	PD3	PD2	PD1	PD0
Read/Write	R							
After reset	"1"							

PD  
(0x4000\_00C0)

Port D function register 1

	7	6	5	4	3	2	1	0
Bit Symbol	—	—	—	—	PD3F1	PD2F1	PD1F1	PD0F1
Read/Write	R				R/W			
After reset	0				0	0	0	0
Function	"0" is read.				0:PORT 1: TB6IN1	0:PORT 1: TB6IN0	0:PORT 1: TB5IN1	0:PORT 1: TB5IN0

PDFR1  
(0x4000\_00C8)

Port D pull-up control register

	7	6	5	4	3	2	1	0
Bit Symbol	PD7UP	PD6UP	PD5UP	PD4UP	PD3UP	PD2UP	PD1UP	PD0UP
Read/Write	R/W							
After reset	0	0	0	0	0	0	0	0
Function	Pull-up 0:off 1:on	Pull-up 0:off 1:on	Pull-up 0:off 1:on	Pull-up 0:off 1:on	Pull-up 0:off 1:on	Pull-up 0:off 1:on	Pull-up 0:off 1:on	Pull-up 0:off 1:on

PDPUP  
(0x4000\_00EC)

Port D input enable control register

	7	6	5	4	3	2	1	0
Bit Symbol	PD7IE	PD6IE	PD5IE	PD4IE	PD3IE	PD2IE	PD1IE	PD0IE
Read/Write	R/W							
After reset	0	0	0	0	0	0	0	0
Function	Input 0:disabled 1:enabled	Input 0:disabled 1:enabled	Input 0:disabled 1:enabled	Input 0:disabled 1:enabled	Input 0:disabled 1:enabled	Input 0:disabled 1:enabled	Input 0:disabled 1:enabled	Input 0:disabled 1:enabled

PDIE  
(0x4000\_00F8)

### 9.2.7 Port E (PE0~PE6)

The port E is a general-purpose, 7-bit input/output port. For this port, inputs and outputs can be specified in units of bits. Besides the general-purpose port function, the port E performs the serial interface function and the remote control signal preprocessor input function.

Reset initializes all bits of the port E as general-purpose ports with input, output and pull-up disabled.

Port E Circuit Type

	7	6	5	4	3	2	1	0
Type	—	T16	T4	T10	T4	T16	T4	T10

Port E register

	7	6	5	4	3	2	1	0
Bit Symbol	—	PE6	PE5	PE4	PE3	PE2	PE1	PE0
Read/Write	R	R/W						
After reset	"0"	"0"						

PE  
(0x4000\_0100)

Port E control register

		7	6	5	4	3	2	1	0
PECR (0x4000_0104)	Bit Symbol	—	PE6C	PE5C	PE4C	PE3C	PE2C	PE1C	PE0C
	Read/Write	R	R/W						
	After reset	0	0	0	0	0	0	0	0
	Function	"0" is read.	0: Output disabled 1: Output enabled						

Port E function register 1

		7	6	5	4	3	2	1	0
PEFR1 (0x4000_0108)	Bit Symbol	—	PE6F1	PE5F1	PE4F1	PE3F1	PE2F1	PE1F1	PE0F1
	Read/Write	R	R/W						
	After reset	0	0	0	0	0	0	0	0
	Function	"0" is read.	0:PORT 1:SCLK1	0:PORT 1:RXD1	0:PORT 1:TXD1	0:PORT 1:RXIN0	0:PORT 1:SCLK0	0:PORT 1:RXD0	0:PORT 1:TXD0

Port E function register 2

		7	6	5	4	3	2	1	0
PEFR2 (0x4000_010C)	Bit Symbol	—	PE6F2	—	—	—	PE2F2	—	—
	Read/Write	R	R/W	R			R/W	R	
	After reset	0	0	0			0	0	
	Function	"0" is read.	0:PORT 1:CTS1	"0" is read.			0:PORT 1:CTS0	"0" is read.	

Port E open drain control register

		7	6	5	4	3	2	1	0
PEOD (0x4000_0128)	Bit Symbol	—	PE6OD	PE5OD	PE4OD	PE3OD	PE2OD	PE1OD	PE0OD
	Read/Write	R	R/W	R/W	R/W	R/W	R/W	R/W	R/W
	After reset	0	0	0	0	0	0	0	0
	Function	"0" is read.	0:CMOS 1:Open drain	0:CMOS 1:Open drain	0:CMOS 1:Open drain	0:CMOS 1:Open drain	0:CMOS 1:Open drain	0:CMOS 1:Open drain	0:CMOS 1:Open drain

Port E pull-up control register

		7	6	5	4	3	2	1	0
PEPUP (0x4000_012C)	Bit Symbol	—	PE6UP	PE5UP	PE4UP	PE3UP	PE2UP	PE1UP	PE0UP
	Read/Write	R	R/W						
	After reset	0	0	0	0	0	0	0	0
	Function	"0" is read.	Pull-up 0:off 1:on	Pull-up 0:off 1:on	Pull-up 0:off 1:on	Pull-up 0:off 1:on	Pull-up 0:off 1:on	Pull-up 0:off 1:on	Pull-up 0:off 1:on

Port E input enable control register

		7	6	5	4	3	2	1	0
PEIE (0x4000_0138)	Bit Symbol	—	PE6IE	PE5IE	PE4IE	PE3IE	PE2IE	PE1IE	PE0IE
	Read/Write	R	R/W						
	After reset	0	0	0	0	0	0	0	0
	Function	"0" is read.	Input 0:disabled 1:enabled	Input 0:disabled 1:enabled	Input 0:disabled 1:enabled	Input 0:disabled 1:enabled	Input 0:disabled 1:enabled	Input 0:disabled 1:enabled	Input 0:disabled 1:enabled

**9.2.8 Port F (PF0~PF7)**

The port F is a general-purpose, 8-bit input/output port. For this port, inputs and outputs can be specified in units of bits. Besides the general-purpose port function, the port F performs the functions of the serial interface, the remote control signal preprocessor, the serial bus interface and the external interrupt input.

To use the external interrupt input for releasing STOP mode, select this function in the PFFR register and enable input in the PFIE register. These settings enable the interrupt input even if the CGSTBYCR<DRVE> bit in the clock/mode control block is set to stop driving of pins during STOP mode.

**(Note) In modes other than STOP mode, interrupt input is enabled regardless of the PxFR register setting as long as input is enabled in PxIE. Make sure to disable unused interrupts when programming the device.**

Reset initializes all bits of the port F as general-purpose ports with input, output and pull-up disabled.

Port F Circuit Type

	7	6	5	4	3	2	1	0
Type	T8	T13	T13	T13	T4	T16	T4	T10

Port F register

PF  
(0x4000\_0140)

	7	6	5	4	3	2	1	0
Bit Symbol	PF7	PF6	PF5	PF4	PF3	PF2	PF1	PF0
Read/Write	R/W							
After reset	"0"							

Port F control register

	7	6	5	4	3	2	1	0
Bit Symbol	PF7C	PF6C	PF5C	PF4C	PF3C	PF2C	PF1C	PF0C
Read/Write	R/W							
After reset	0	0	0	0	0	0	0	0
Function	0: Output disabled 1: Output enabled							

PFCR  
(0x4000\_0144)

Port F function register 1

	7	6	5	4	3	2	1	0
Bit Symbol	PF7F1	PF6F1	PF5F1	PF4F1	PF3F1	PF2F1	PF1F1	PF0F1
Read/Write	R/W							
After reset	0	0	0	0	0	0	0	0
Function	0:PORT 1: INT5	0:PORT 1: SCK1	0:PORT 1: SI1/ SCL1	0:PORT 1: SO1/ SDA1	0:PORT 1: RXIN1	0:PORT 1: SCLK2	0:PORT 1: RXD2	0:PORT 1: TXD2

PFFR1  
(0x4000\_0148)

Port F function register 2

	7	6	5	4	3	2	1	0
Bit Symbol	—	—	—	—	—	PF2F2	—	—
Read/Write	R					R/W	R	
After reset	0					0	0	
Function	"0" is read.					0:PORT 1:CTS2	"0" is read.	

PFFR2  
(0x4000\_014C)

Port F open drain control register

	7	6	5	4	3	2	1	0
Bit Symbol	PF7OD	PF6OD	PF5OD	PF4OD	PF3OD	PF2OD	PF1OD	PF0OD
Read/Write	R/W	R/W	R/W	R/W	R/W	R/W	R/W	R/W
After reset	0	0	0	0	0	0	0	0
Function	0:CMOS 1:Open drain	0:CMOS 1:Open drain	0:CMOS 1:Open drain	0:CMOS 1:Open drain	0:CMOS 1:Open drain	0:CMOS 1:Open drain	0:CMOS 1:Open drain	0:CMOS 1:Open drain

PFOD  
(0x4000\_0168)

Port F pull-up control register

	7	6	5	4	3	2	1	0
Bit Symbol	PF7UP	PF6UP	PF5UP	PF4UP	PF3UP	PF2UP	PF1UP	PF0UP
Read/Write	R/W							
After reset	0	0	0	0	0	0	0	0
Function	Pull-up 0:off 1:on	Pull-up 0:off 1:on	Pull-up 0:off 1:on	Pull-up 0:off 1:on	Pull-up 0:off 1:on	Pull-up 0:off 1:on	Pull-up 0:off 1:on	Pull-up 0:off 1:on

PFPUP  
(0x4000\_016C)

Port F input enable control register

	7	6	5	4	3	2	1	0
Bit Symbol	PF7IE	PF6IE	PF5IE	PF4IE	PF3IE	PF2IE	PF1IE	PF0IE
Read/Write	R/W							
After reset	0	0	0	0	0	0	0	0
Function	Input 0:disabled 1:enabled	Input 0:disabled 1:enabled	Input 0:disabled 1:enabled	Input 0:disabled 1:enabled	Input 0:disabled 1:enabled	Input 0:disabled 1:enabled	Input 0:disabled 1:enabled	Input 0:disabled 1:enabled

PFIE  
(0x4000\_0178)

### 9.2.9 Port G (PG0~PG7)

The port G is a general-purpose, 8-bit input/output port. For this port, inputs and outputs can be specified in units of bits. Besides the general-purpose port function, the port G performs the functions of the serial bus interface, the external interrupt input, and the 16-bit timer output.

To use the external interrupt input for releasing STOP mode, select this function in the PGFR register and enable input in the PGIE register. These settings enable the interrupt input even if the CGSTBYCR<DRVE> bit in the clock/mode control block is set to stop driving of pins during STOP mode.

<p><b>(Note)</b> In modes other than STOP mode, interrupt input is enabled regardless of the PxFR register setting as long as input is enabled in PxIE. Make sure to disable unused interrupts when programming the device.</p>
---

Reset initializes all bits of the port G as general-purpose ports with input, output and pull-up disabled.

Port G Circuit Type

	7	6	5	4	3	2	1	0
Type	T10	T13	T13	T13	T8	T13	T13	T13

Port G register

PG  
(0x4000\_0180)

	7	6	5	4	3	2	1	0
Bit Symbol	PG7	PG6	PG5	PG4	PG3	PG2	PG1	PG0
Read/Write	R/W							
After reset	"0"							

Port G control register

PGCR  
(0x4000\_0184)

	7	6	5	4	3	2	1	0
Bit Symbol	PG7C	PG6C	PG5C	PG4C	PG3C	PG2C	PG1C	PG0C
Read/Write	R/W							
After reset	0	0	0	0	0	0	0	0
Function	0: Output disabled 1: Output enabled							

Port G function register 1

PGFR1  
(0x4000\_0188)

	7	6	5	4	3	2	1	0
Bit Symbol	PG7F1	PG6F1	PG5F1	PG4F1	PG3F1	PG2F1	PG1F1	PG0F1
Read/Write	R/W							
After reset	0	0	0	0	0	0	0	0
Function	0:PORT 1: TB8OUT	0:PORT 1: SCK2	0:PORT 1: SI2/ SCL2	0:PORT 1: SO2/ SDA2	0:PORT 1: INT4	0:PORT 1: SCK0	0:PORT 1: SI0/ SCL0	0:PORT 1: SO0/ SDA0

Port G open drain control register

PGOD  
(0x4000\_01A8)

	7	6	5	4	3	2	1	0
Bit Symbol	PG7OD	PG6OD	PG5OD	PG4OD	PG3OD	PG2OD	PG1OD	PG0OD
Read/Write	R/W	R/W	R/W	R/W	R/W	R/W	R/W	R/W
After reset	0	0	0	0	0	0	0	0
Function	0:CMOS 1:Open drain	0:CMOS 1:Open drain	0:CMOS 1:Open drain	0:CMOS 1:Open drain	0:CMOS 1:Open drain	0:CMOS 1:Open drain	0:CMOS 1:Open drain	0:CMOS 1:Open drain

Port G pull-up control register

PGPUP  
(0x4000\_01AC)

	7	6	5	4	3	2	1	0
Bit Symbol	PG7UP	PG6UP	PG5UP	PG4UP	PG3UP	PG2UP	PG1UP	PG0UP
Read/Write	R/W							
After reset	0	0	0	0	0	0	0	0
Function	Pull-up 0:off 1:on	Pull-up 0:off 1:on	Pull-up 0:off 1:on	Pull-up 0:off 1:on	Pull-up 0:off 1:on	Pull-up 0:off 1:on	Pull-up 0:off 1:on	Pull-up 0:off 1:on

Port G input enable control register

PGIE  
(0x4000\_01B8)

	7	6	5	4	3	2	1	0
Bit Symbol	PG7IE	PG6IE	PG5IE	PG4IE	PG3IE	PG2IE	PG1IE	PG0IE
Read/Write	R/W							
After reset	0	0	0	0	0	0	0	0
Function	Input 0:disabled 1:enabled	Input 0:disabled 1:enabled	Input 0:disabled 1:enabled	Input 0:disabled 1:enabled	Input 0:disabled 1:enabled	Input 0:disabled 1:enabled	Input 0:disabled 1:enabled	Input 0:disabled 1:enabled

### 9.2.10 Port H (PH0~PH7)

The port H is a general-purpose, 8-bit input/output port. For this port, inputs and outputs can be specified in units of bits. Besides the general-purpose port function, the port H performs the functions of the 16-bit timer input and the operation mode setting.

While a reset signal is in “0”state, the PH0 input and pull-up are enabled. At the rising edge of the reset signal, if PH0 is “1”, the device enters single mode and boots from the on-chip flash memory. If PH0 is “0”, the device enters single boot mode and boots from the internal boot program. For details of single boot mode, refer to “Chapter 17 Flash Memory Operation”.

Reset initializes all bits of the port H as general-purpose ports with input and output disabled. Pull-up is enabled for PH0 and disabled for PH1 through PH7.

Port H Circuit Type

	7	6	5	4	3	2	1	0
Type	T3	T3	T3	T3	T3	T3	T3	T5

Port H register

	7	6	5	4	3	2	1	0	
PH (0x4000_01C0)	Bit Symbol	PH7	PH6	PH5	PH4	PH3	PH2	PH1	PH0
	Read/Write	R/W							
	After reset	"0"							

Port H control register

	7	6	5	4	3	2	1	0	
PHCR (0x4000_01C4)	Bit Symbol	PH7C	PH6C	PH5C	PH4C	PH3C	PH2C	PH1C	PH0C
	Read/Write	R/W							
	After reset	0	0	0	0	0	0	0	0
	Function	0: Output disabled 1: Output enabled							

Port H function register 1

	7	6	5	4	3	2	1	0	
PHFR1 (0x4000_01C8)	Bit Symbol	PH7F1	PH6F1	PH5F1	PH4F1	PH3F1	PH2F1	PH1F1	PH0F1
	Read/Write	R/W							
	After reset	0	0	0	0	0	0	0	0
	Function	0:PORT 1: TB3IN1	0:PORT 1: TB3IN0	0:PORT 1: TB2IN1	0:PORT 1: TB2IN0	0:PORT 1: TB1IN1	0:PORT 1: TB1IN0	0:PORT 1: TB0IN1	0:PORT 1: TB0IN0

Port H pull-up control register

	7	6	5	4	3	2	1	0	
PHPUP (0x4000_01EC)	Bit Symbol	PH7UP	PH6UP	PH5UP	PH4UP	PH3UP	PH2UP	PH1UP	PH0UP
	Read/Write	R/W							
	After reset	0	0	0	0	0	0	0	1
	Function	Pull-up 0:off 1:on	Pull-up 0:off 1:on	Pull-up 0:off 1:on	Pull-up 0:off 1:on	Pull-up 0:off 1:on	Pull-up 0:off 1:on	Pull-up 0:off 1:on	Pull-up 0:off 1:on

Port H input enable control register

	7	6	5	4	3	2	1	0	
PHIE (0x4000_01F8)	Bit Symbol	PH7IE	PH6IE	PH5IE	PH4IE	PH3IE	PH2IE	PH1IE	PH0IE
	Read/Write	R/W							
	After reset	0	0	0	0	0	0	0	0
	Function	Input 0:disabled 1:enabled	Input 0:disabled 1:enabled	Input 0:disabled 1:enabled	Input 0:disabled 1:enabled	Input 0:disabled 1:enabled	Input 0:disabled 1:enabled	Input 0:disabled 1:enabled	Input 0:disabled 1:enabled

9.2.11 Port I (PI0~PI7)

The port I is a general-purpose, 8-bit input/output port. For this port, inputs and outputs can be specified in units of bits. Besides the general-purpose port function, the port I performs the 16-bit timer input/output function.

Reset initializes all bits of the port I as general-purpose ports with input, output and pull-up disabled.

Port I Circuit Type

	7	6	5	4	3	2	1	0
Type	T3	T3	T9	T9	T9	T9	T9	T9

Port I register

	7	6	5	4	3	2	1	0
Bit Symbol	PI7	PI6	PI5	PI4	PI3	PI2	PI1	PI0
Read/Write	R/W							
After reset	"0"							

PI  
(0x4000\_0200)

Port I control register

	7	6	5	4	3	2	1	0
Bit Symbol	PI7C	PI6C	PI5C	PI4C	PI3C	PI2C	PI1C	PI0C
Read/Write	R/W							
After reset	0	0	0	0	0	0	0	0
Function	0: Output disabled 1: Output enabled							

PICR  
(0x4000\_0204)

Port I function register 1

	7	6	5	4	3	2	1	0
Bit Symbol	PI7F1	PI6F1	PI5F1	PI4F1	PI3F1	PI2F1	PI1F1	PI0F1
Read/Write	R/W							
After reset	0	0	0	0	0	0	0	0
Function	0:PORT 1: TB4IN1	0:PORT 1: TB4IN0	0:PORT 1: TB5OUT	0:PORT 1: TB4OUT	0:PORT 1: TB3OUT	0:PORT 1: TB2OUT	0:PORT 1: TB1OUT	0:PORT 1: TB0OUT

PIFR1  
(0x4000\_0208)

Port I pull-up control register

	7	6	5	4	3	2	1	0
Bit Symbol	PI7UP	PI6UP	PI5UP	PI4UP	PI3UP	PI2UP	PI1UP	PI0UP
Read/Write	R/W							
After reset	0	0	0	0	0	0	0	0
Function	Pull-up 0:off 1:on	Pull-up 0:off 1:on	Pull-up 0:off 1:on	Pull-up 0:off 1:on	Pull-up 0:off 1:on	Pull-up 0:off 1:on	Pull-up 0:off 1:on	Pull-up 0:off 1:on

PIPUP  
(0x4000\_022C)

Port I input enable control register

	7	6	5	4	3	2	1	0
Bit Symbol	PI7IE	PI6IE	PI5IE	PI4IE	PI3IE	PI2IE	PI1IE	PI0IE
Read/Write	R/W							
After reset	0	0	0	0	0	0	0	0
Function	Input 0:disabled 1:enabled	Input 0:disabled 1:enabled	Input 0:disabled 1:enabled	Input 0:disabled 1:enabled	Input 0:disabled 1:enabled	Input 0:disabled 1:enabled	Input 0:disabled 1:enabled	Input 0:disabled 1:enabled

PIIE  
(0x4000\_0238)

### 9.2.12 Port J (PJ0~PJ7)

The port J is a general-purpose, 8-bit input/output port. For this port, inputs and outputs can be specified in units of bits. Besides the general-purpose port function, the port J performs the functions of the 16-bit timer output and the external interrupt input.

To use the external interrupt input for releasing STOP mode, select this function in the PJFR register and enable input in the PJIE register. These settings enable the interrupt input even if the CGSTBYCR<DRVE> bit in the clock/mode control block is set to stop driving of pins during STOP mode.

**(Note) In modes other than STOP mode, interrupt input is enabled regardless of the PxFR register setting as long as input is enabled in PxIE. Make sure to disable unused interrupts when programming the device.**

Reset initializes all bits of the port J as general-purpose ports with input, output and pull-up disabled.

Port J Circuit Type

	7	6	5	4	3	2	1	0
Type	T7	T7	T9	T9	T7	T7	T7	T7

Port J register

	7	6	5	4	3	2	1	0
Bit Symbol	PJ7	PJ6	PJ5	PJ4	PJ3	PJ2	PJ1	PJ0
Read/Write	R/W							
After reset	"0"							

PJ  
(0x4000\_0240)

Port J control register

	7	6	5	4	3	2	1	0
Bit Symbol	PJ7C	PJ6C	PJ5C	PJ4C	PJ3C	PJ2C	PJ1C	PJ0C
Read/Write	R/W							
After reset	0	0	0	0	0	0	0	0
Function	0: Output disabled 1: Output enabled							

PJCR  
(0x4000\_0244)

Port J function register 1

	7	6	5	4	3	2	1	0
Bit Symbol	PJ7F1	PJ6F1	PJ5F1	PJ4F1	PJ3F1	PJ2F1	PJ1F1	PJ0F1
Read/Write	R/W							
After reset	0	0	0	0	0	0	0	0
Function	0:PORT 1: INT7	0:PORT 1: INT6	0:PORT 1: TB7OUT	0:PORT 1: TB6OUT	0:PORT 1: INT3	0:PORT 1: INT2	0:PORT 1: INT1	0:PORT 1: INT0

PJFR1  
(0x4000\_0248)

Port J pull-up control register

	7	6	5	4	3	2	1	0
Bit Symbol	PJ7UP	PJ6UP	PJ5UP	PJ4UP	PJ3UP	PJ2UP	PJ1UP	PJ0UP
Read/Write	R/W							
After reset	0	0	0	0	0	0	0	0
Function	Pull-up 0:off 1:on	Pull-up 0:off 1:on	Pull-up 0:off 1:on	Pull-up 0:off 1:on	Pull-up 0:off 1:on	Pull-up 0:off 1:on	Pull-up 0:off 1:on	Pull-up 0:off 1:on

PJPUP  
(0x4000\_026C)

Port J input enable control register

	7	6	5	4	3	2	1	0
Bit Symbol	PJ7IE	PJ6IE	PJ5IE	PJ4IE	PJ3IE	PJ2IE	PJ1IE	PJ0IE
Read/Write	R/W							
After reset	0	0	0	0	0	0	0	0
Function	Input 0:disabled 1:enabled	Input 0:disabled 1:enabled	Input 0:disabled 1:enabled	Input 0:disabled 1:enabled	Input 0:disabled 1:enabled	Input 0:disabled 1:enabled	Input 0:disabled 1:enabled	Input 0:disabled 1:enabled

PJIE  
(0x4000\_0278)

### 9.2.13 Port K (PK0~PK2)

The port K is a general-purpose, 3-bit input/output port. For this port, inputs and outputs can be specified in units of bits. Besides the general-purpose port function, the port K performs the functions of the 16-bit timer output, the CEC input, the clock output and the alarm output.

Reset initializes all bits of the port K as general-purpose ports with input, output and pull-up disabled.

<b>(Note)</b> PK0 is an Nch open drain port.
--

Port K Circuit Type

	7	6	5	4	3	2	1	0
Type	—	—	—	—	—	T9	T15	T14

Port K register

PK  
(0x4000\_0280)

	7	6	5	4	3	2	1	0
Bit Symbol	—	—	—	—	—	PK2	PK1	PK0
Read/Write	R					R/W		
After reset	"0" is read.					"0"		

Port K control register

PKCR  
(0x4000\_0284)

	7	6	5	4	3	2	1	0
Bit Symbol	—	—	—	—	—	PK2C	PK1C	PK0C
Read/Write	R					R/W		
After reset	0					0	0	0
Function	"0" is read.					0: Output disabled 1: Output enabled		

Port K function register 1

PKFR1  
(0x4000\_0288)

	7	6	5	4	3	2	1	0
Bit Symbol	—	—	—	—	—	PK2F1	PK1F1	PK0F1
Read/Write	R					R/W		
After reset	0					0	0	0
Function	"0" is read.					0:PORT 1: TB9OUT	0:PORT 1: SCOUT	0:PORT 1: CEC

Port K function register 2

PKFR2  
(0x4000\_028C)

	7	6	5	4	3	2	1	0
Bit Symbol	—	—	—	—	—	—	PK2F1	—
Read/Write	R					R/W		R
After reset	0					0		0
Function	"0" is read.					0:PORT 1: ALARM		"0" is read.

Port K pull-up control register

PKPUP  
(0x4000\_02AC)

	7	6	5	4	3	2	1	0
Bit Symbol	—	—	—	—	—	PK2UP	PK1UP	—
Read/Write	R					R/W		R
After reset	0					0	0	0
Function	"0" is read.					Pull-up 0:off 1:on	Pull-up 0:off 1:on	"0" is read.

Port K input enable control register

PKIE  
(0x4000\_02B8)

	7	6	5	4	3	2	1	0
Bit Symbol	—	—	—	—	—	PK2IE	PK1IE	PK0IE
Read/Write	R					R/W		
After reset	0					0	0	0
Function	"0" is read.					Input 0:disabled 1:enabled	Input 0:disabled 1:enabled	Input 0:disabled 1:enabled

## 9.3 Block Diagrams of Ports

### 9.3.1 Port Types

The ports are classified into 18 types shown below. Please refer to the following pages for the block diagrams of each port type.

Type	GP port	Function 1	Function 2	Analog	Pull up	Pull down	OD	Note
T1	i/o	-	-	-	R	-	-	
T2	i/o	i	-	-	NoR	-	-	
T3	i/o	i	-	-	R	-	-	
T4	i/o	i	-	-	R	-	○	
T5	i/o	i	-	-	NoR	-	-	BOOT input enabled during reset
T6	i/o	i	-	-	-	NoR	-	
T7	i/o	i(int)	-	-	R	-	-	
T8	i/o	i(int)	-	-	R	-	○	
T9	i/o	o	-	-	R	-	-	
T10	i/o	o	-	-	R	-	○	
T11	i/o	o	-	-	R	-	-	Function output triggered by enable signal
T12	i/o	i/o	-	-	NoR	-	-	Function output triggered by enable signal
T13	i/o	i/o	-	-	R	-	○	
T14	i/o	i/o	-	-	-	-	●	Nch open drain port
T15	i/o	o	o	-	R	-	-	
T16	i/o	i/o	i	-	R	-	○	
T17	i	-	-	○	R	-	-	
T18	i	i	-	○	R	-	-	

R : Forced disable during reset.

NoR : Unaffected by reset.

9.3.2 Type T1

Type T1 is a general-purpose input/ output port with pull-up.

Pull-up and output are disabled during reset.

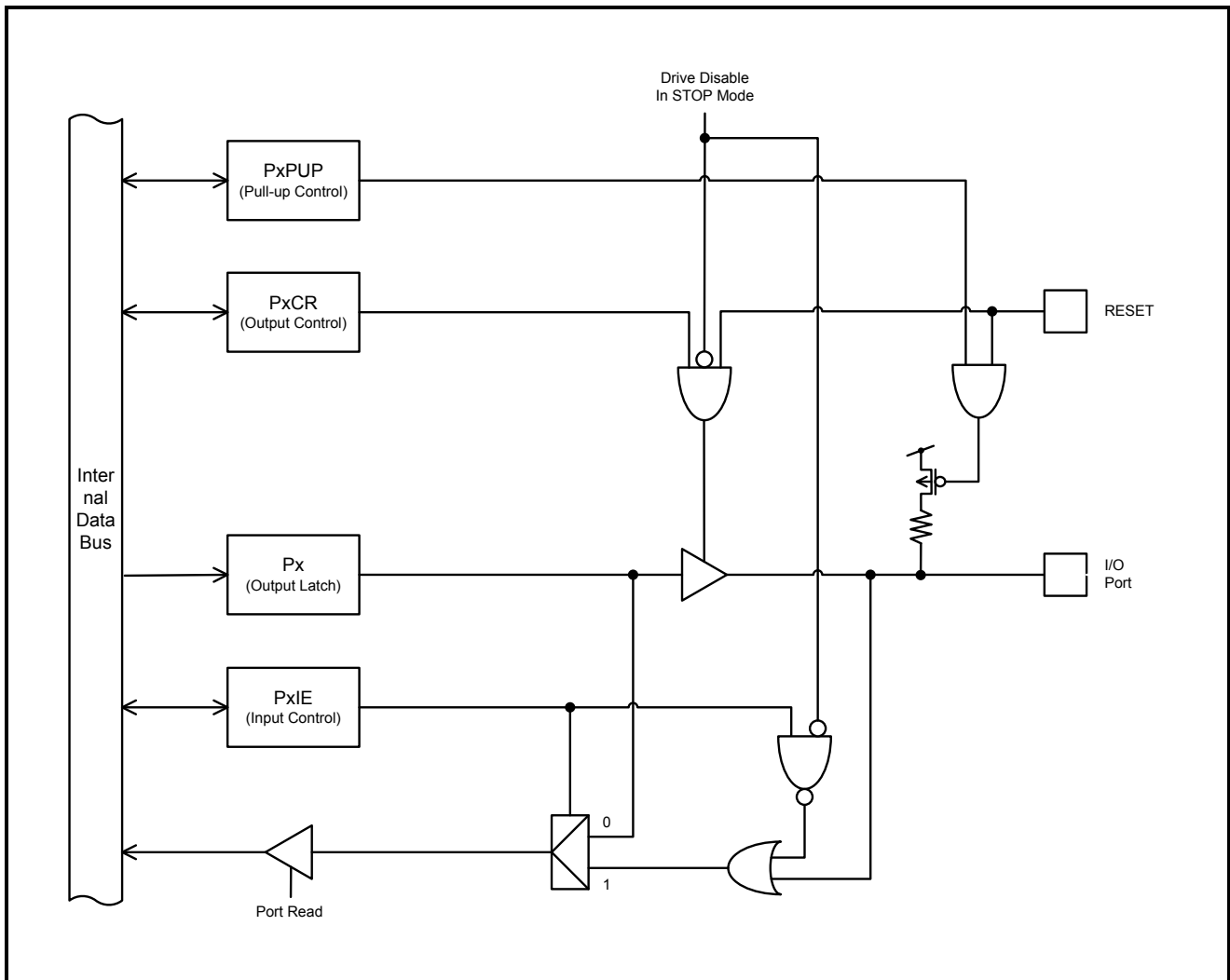

9.3.3 Type T2

Type T2 is a general-purpose input/ output port with pull-up. It is used to input function data as well. Output is disabled during reset.

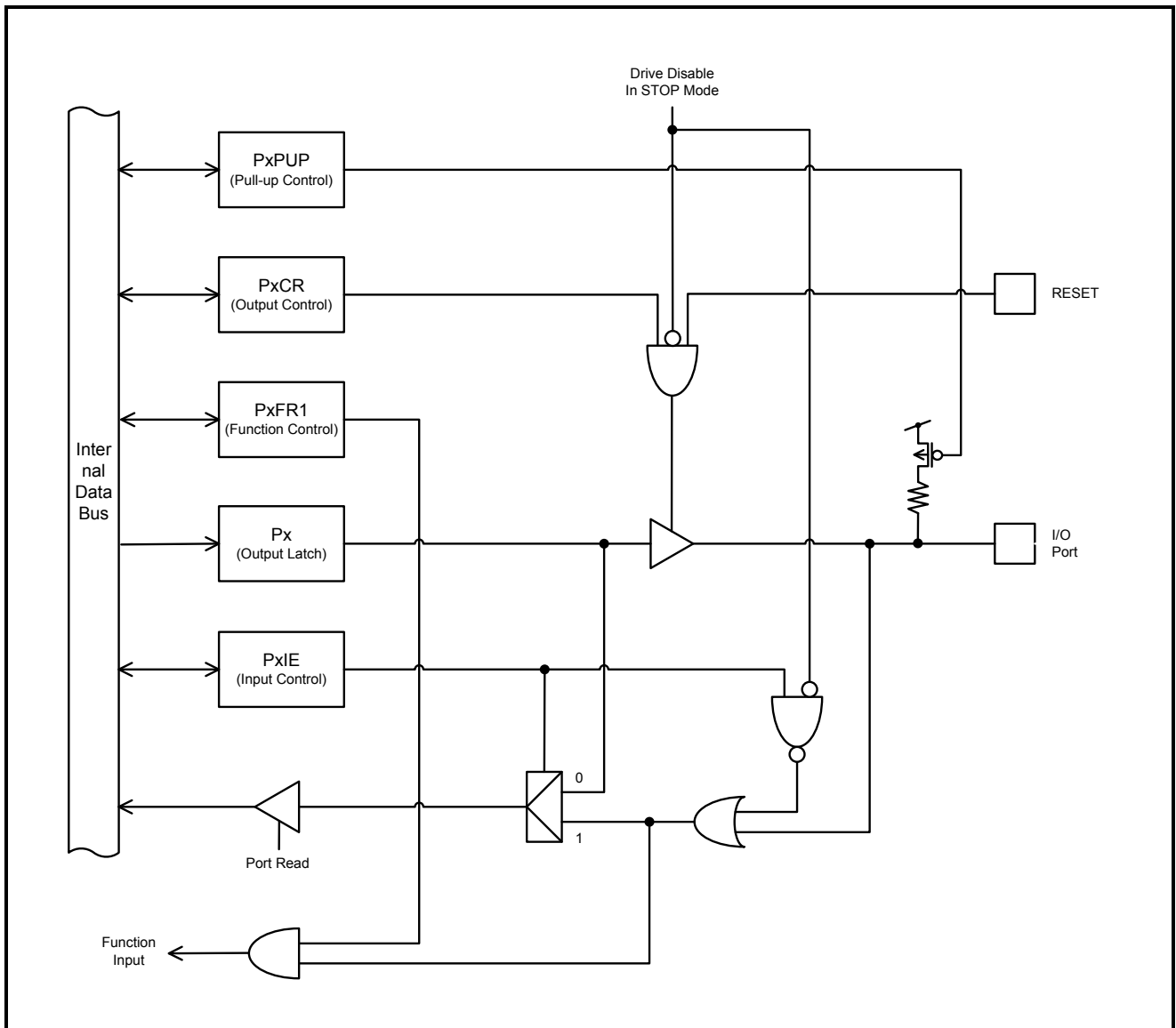

9.3.4 Type T3

Type T3 is a general-purpose input/ output port with pull-up. It is used to input function data as well. Pull-up and output are disabled during reset.

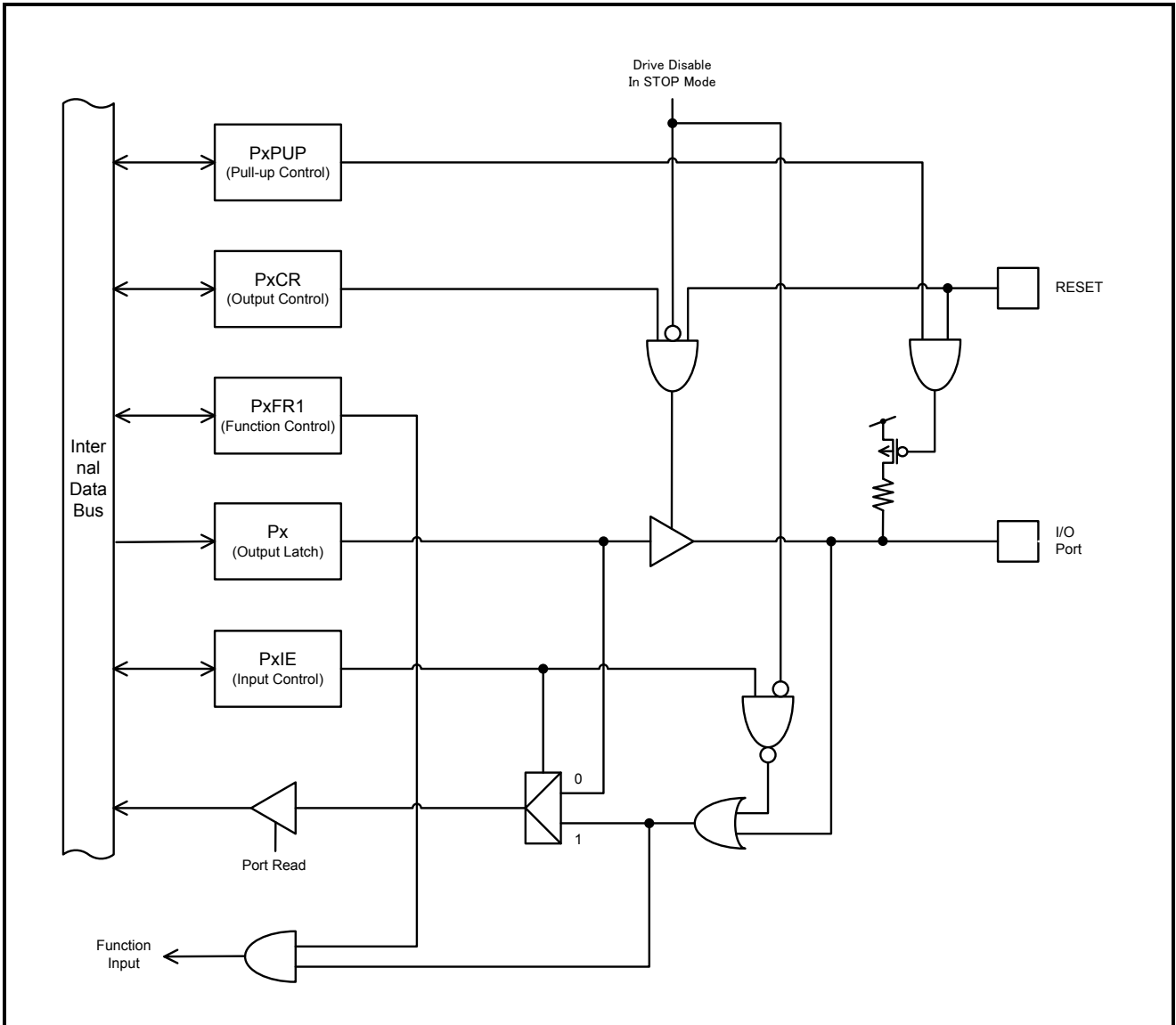

### 9.3.5 Type T4

Type T4 is a general-purpose input/ output port with open drain. It is used to input function data as well.

Pull-up and output are disabled during reset.

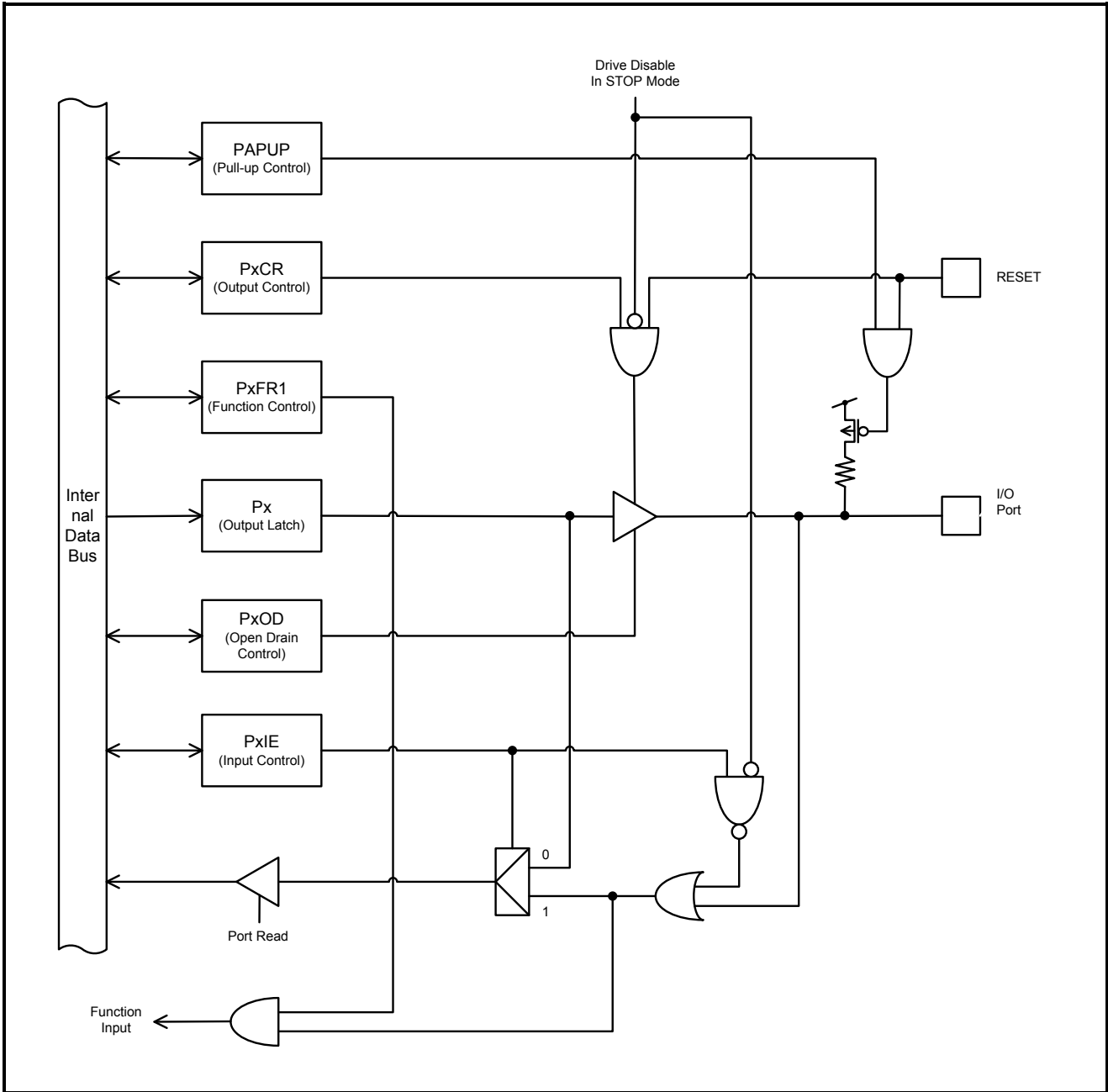

9.3.6 Type T5

Type T5 is a general-purpose input/ output port with pull-up. It is used to input function data as well. During reset, it functions as an input port for a  $\overline{\text{BOOT}}$  signal and pull-up and output are disabled.

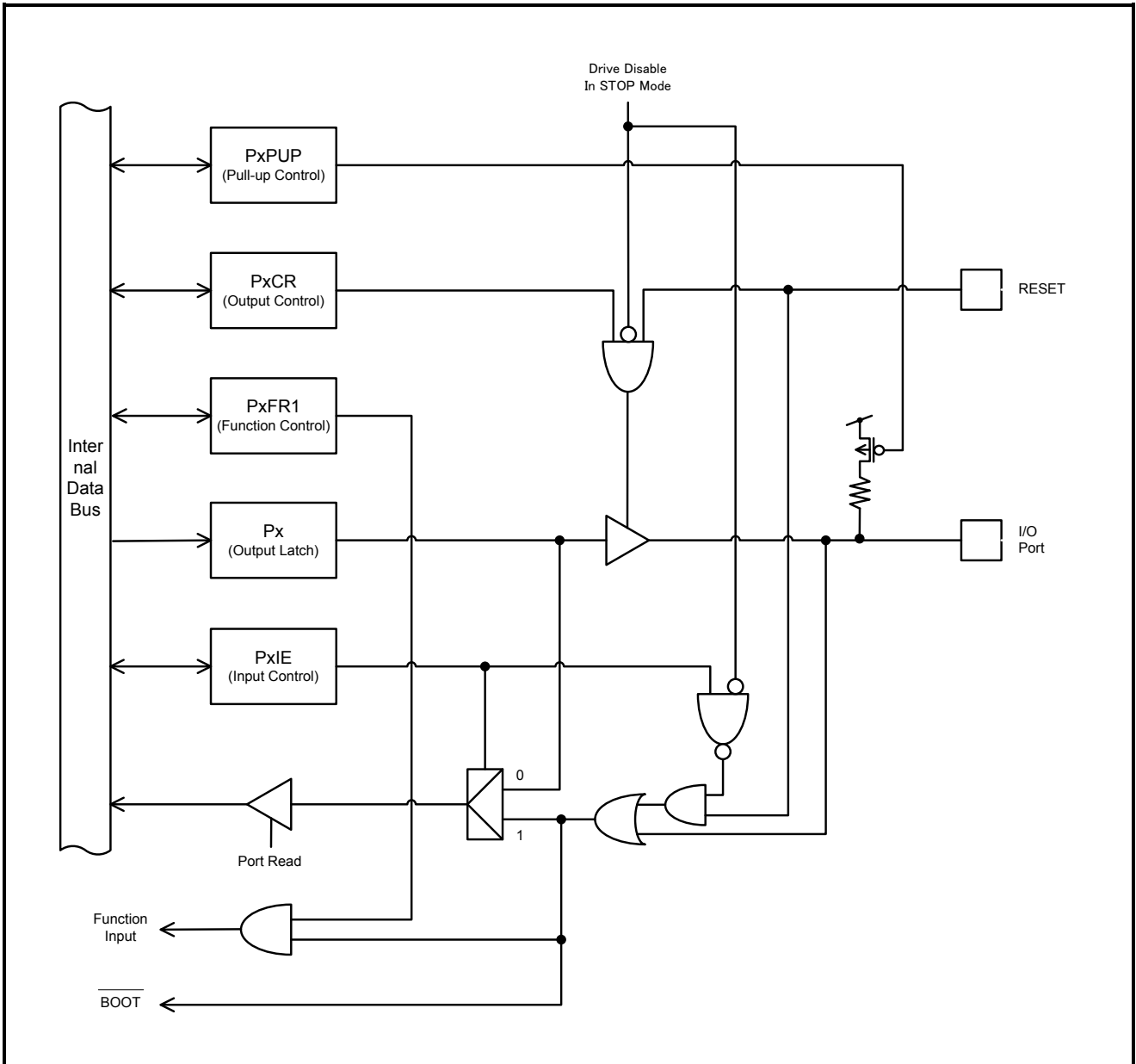

9.3.7 Type T6

Type T6 is a general-purpose port with pull-down. It is used to input function data as well. Output is disabled during reset.

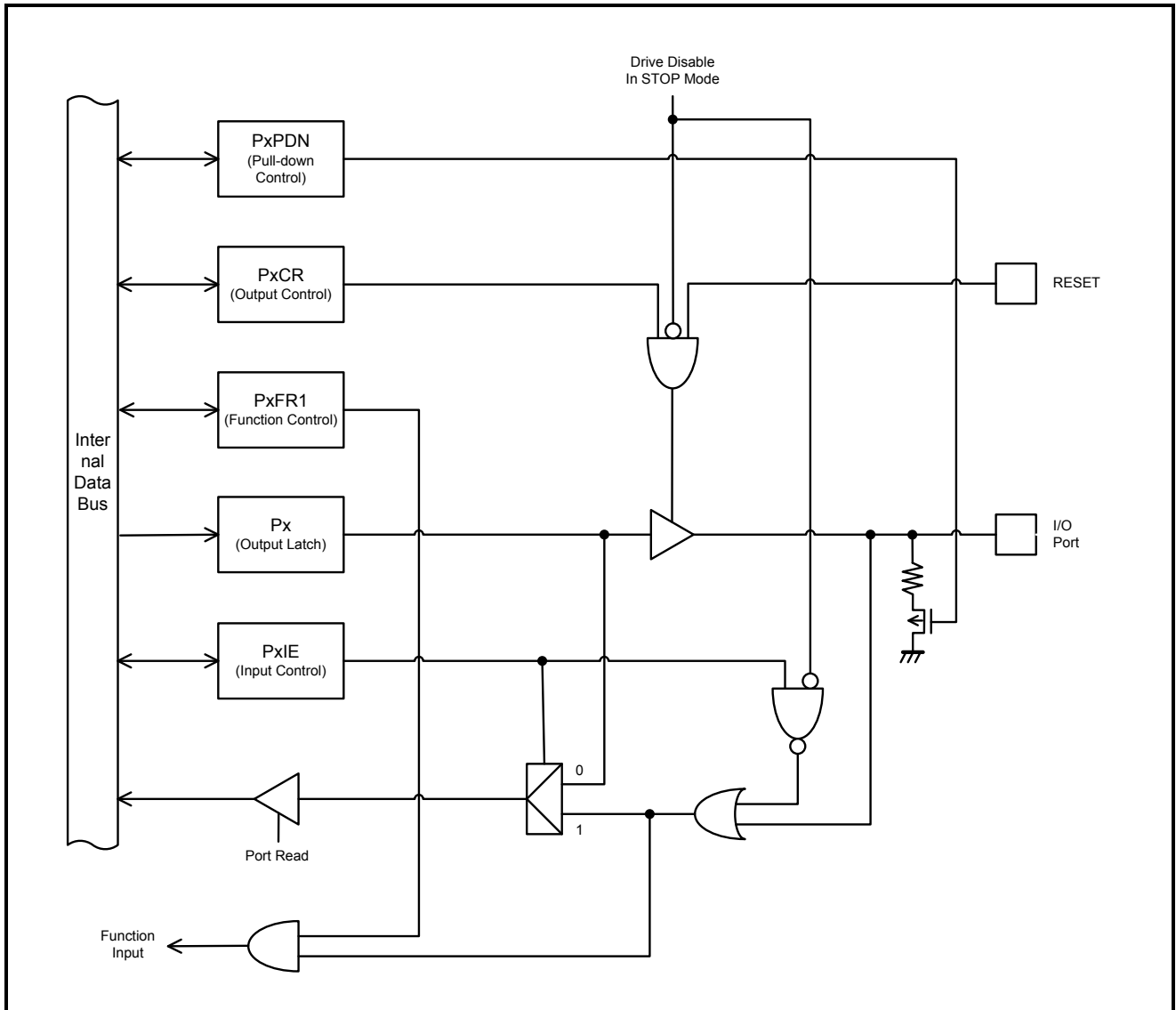

9.3.8 Type T7

Type T7 is a general-purpose input/ output port with pull-up. It is used to input interrupts as well.

Pull-up and output are disabled during reset.

To use the external interrupt input for releasing STOP mode, select this function in the PxFR register and enable input in the PxIE register. These settings enable the interrupt input even if the CGSTBYCR<DRVE> bit in the clock/mode control block is set to stop driving of pins during STOP mode.

**(Note)** In modes other than STOP mode, interrupt input is enabled regardless of the PxFR register setting as long as input is enabled in PxIE. Make sure to disable unused interrupts when programming the device.

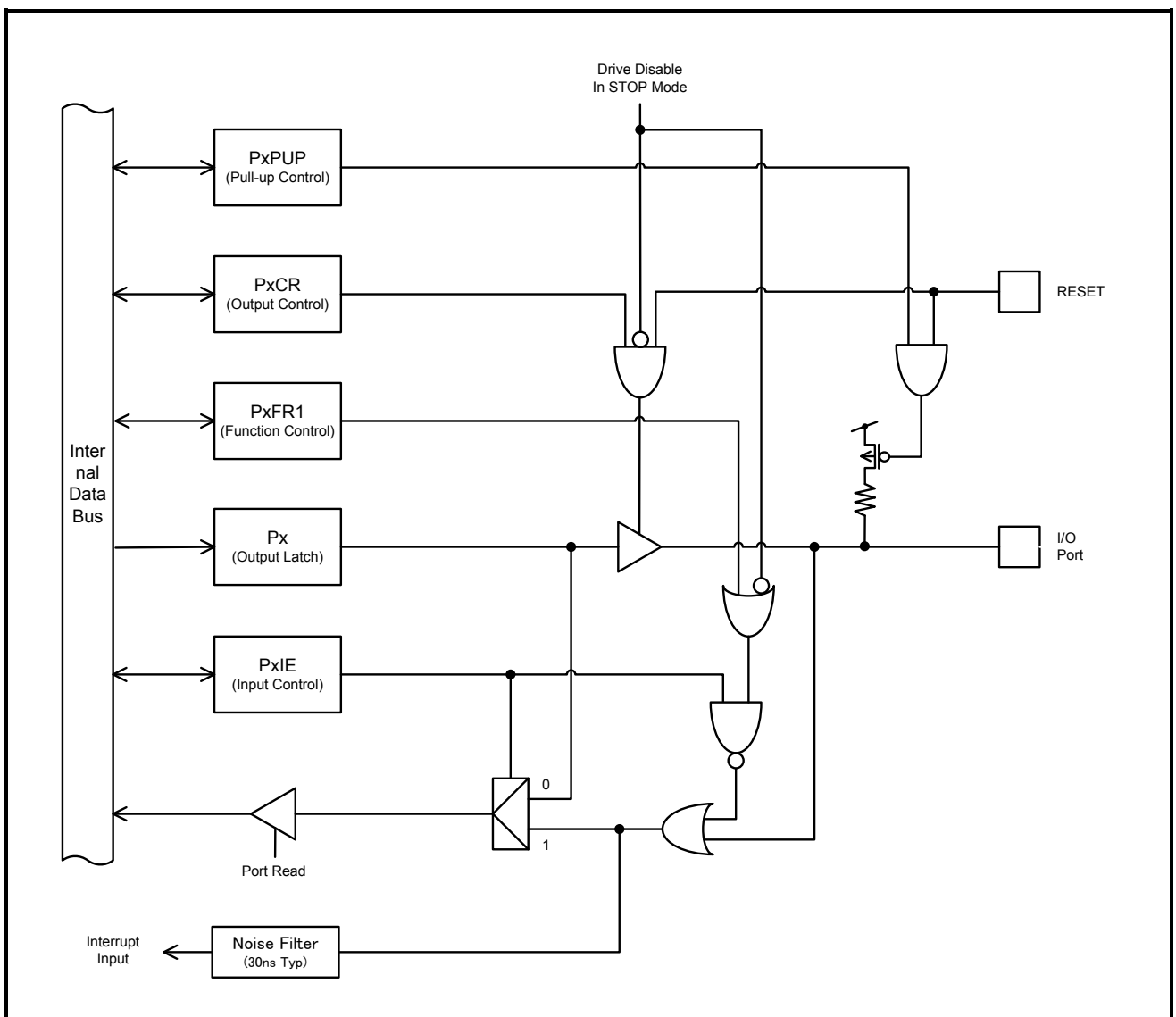

9.3.9 Type T8

Type T8 is a general-purpose input/ output port with pull-up and open drain. It is used to input interrupts as well.

Pull-up and output are disabled during reset.

To use the external interrupt input for releasing STOP mode, select this function in the PxFR register and enable input in the PxIE register. These settings enable the interrupt input even if the CGSTBYCR<DRVE> bit in the clock/ mode control block is set to stop driving of pins during STOP mode.

**(Note)** In modes other than STOP mode, interrupt input is enabled regardless of the PxFR register setting as long as input is enabled in PxIE. Make sure to disable unused interrupts when programming the device.

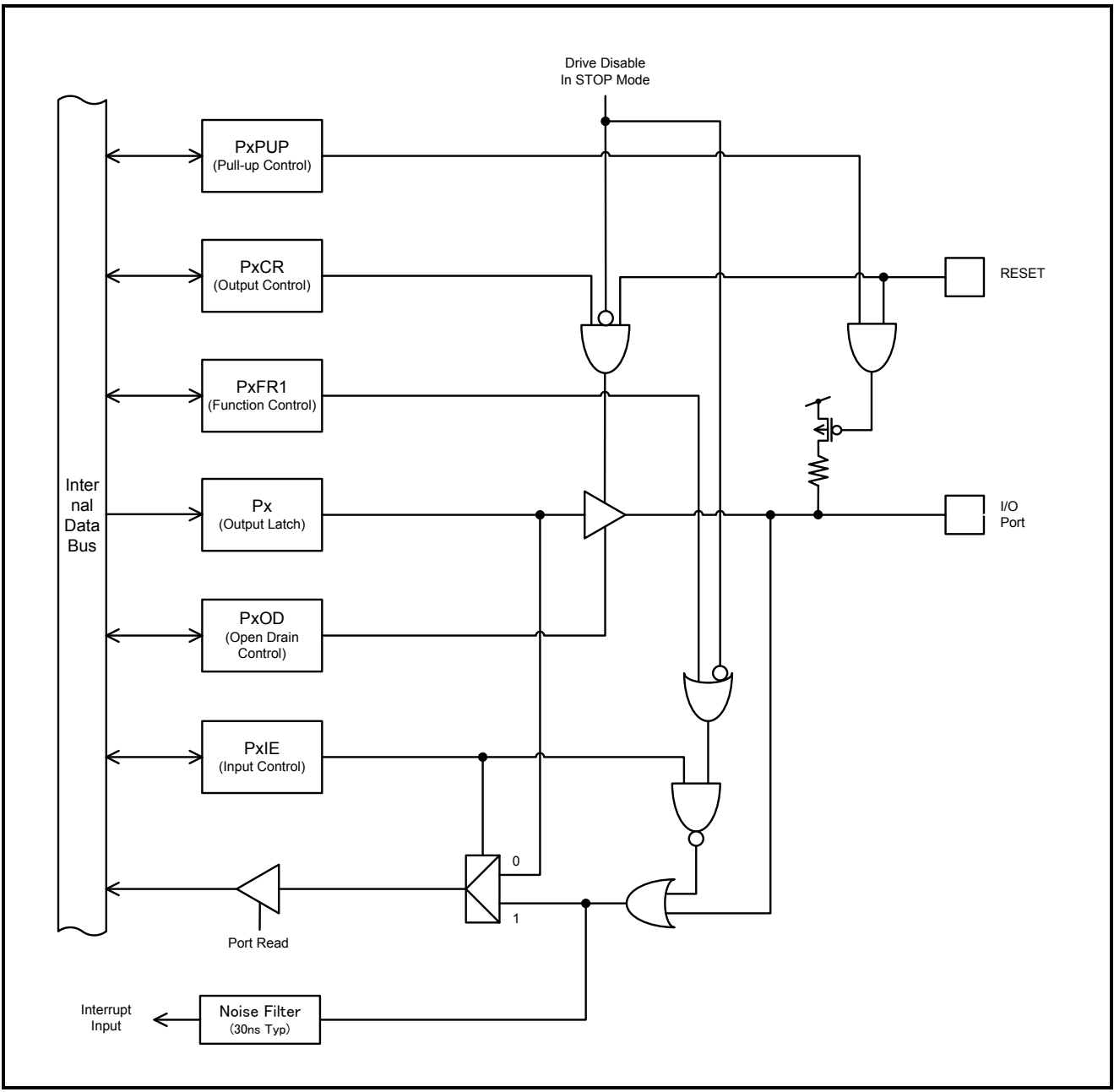

9.3.10 Type T9

Type T9 is a general-purpose input/ output port with pull-up. It is used to output function data as well. Pull-up and output are disabled during reset.

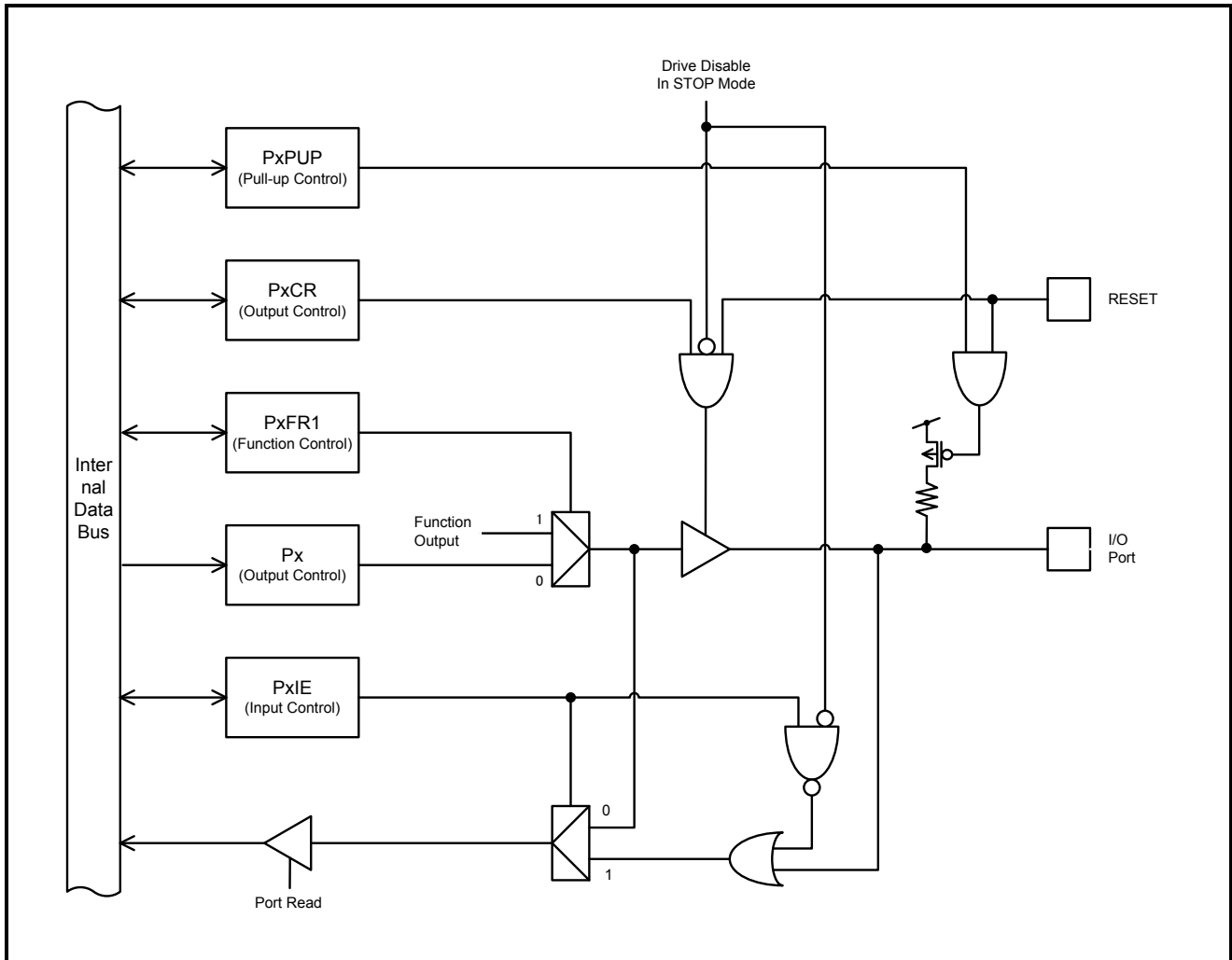

### 9.3.11 Type T10

Type T10 is a general-purpose input/ output port with pull-up and open drain. It is used to output function data as well.

Pull-up and output are disabled during reset.

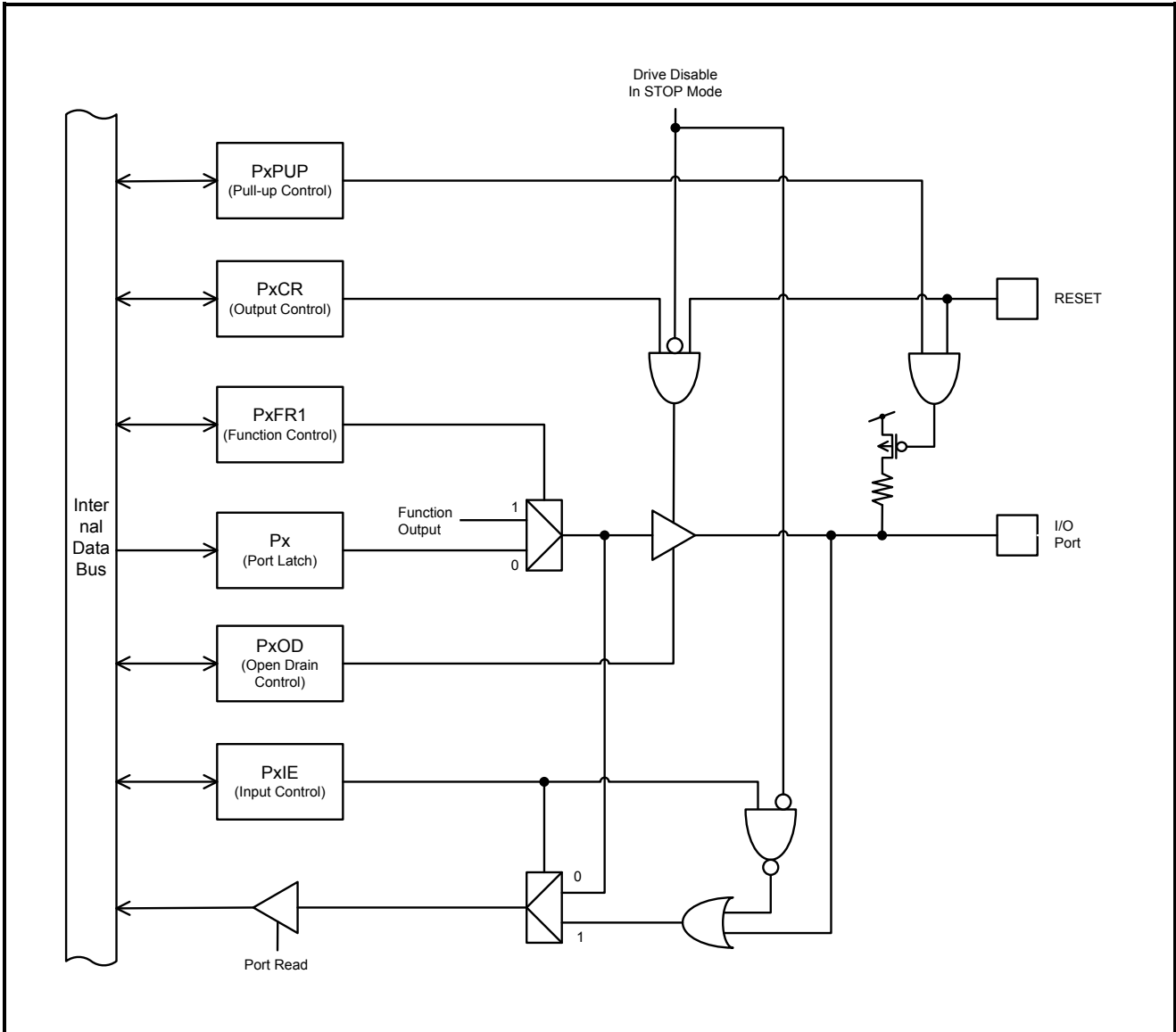

9.3.12 Type T11

Type T11 is a general-purpose input/ output port with pull-up. It is used to output function data as well. The function output is controlled by an enable signal. If enabled, the function data is output.

Pull-up and output are disabled during reset.

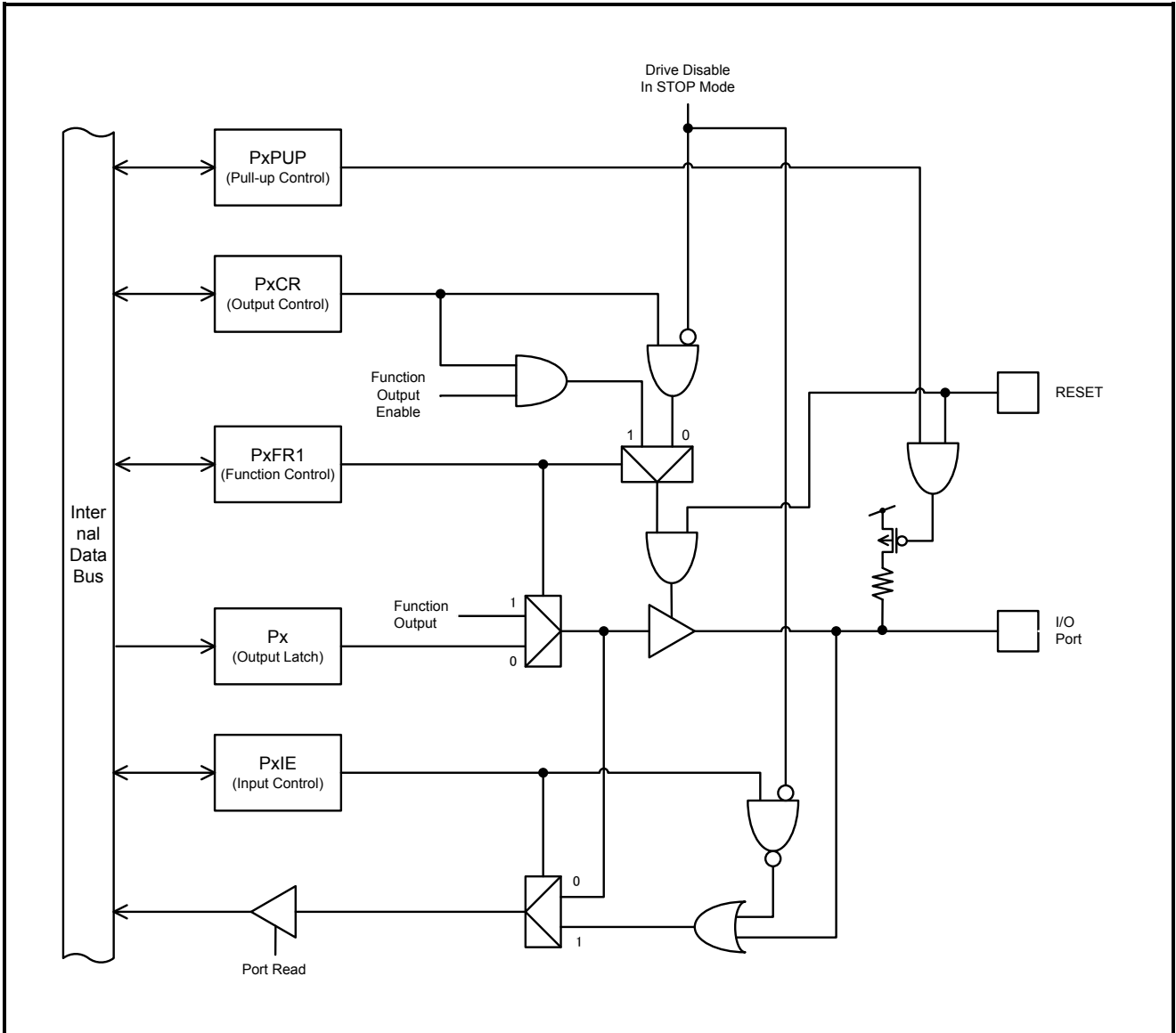

9.3.13 Type T12

Type T12 is a general-purpose input/ output port with pull-up. It is used to input/ output function data as well. The function output is controlled by an enable signal. If enabled, the function data is output.

Output is disabled during reset.

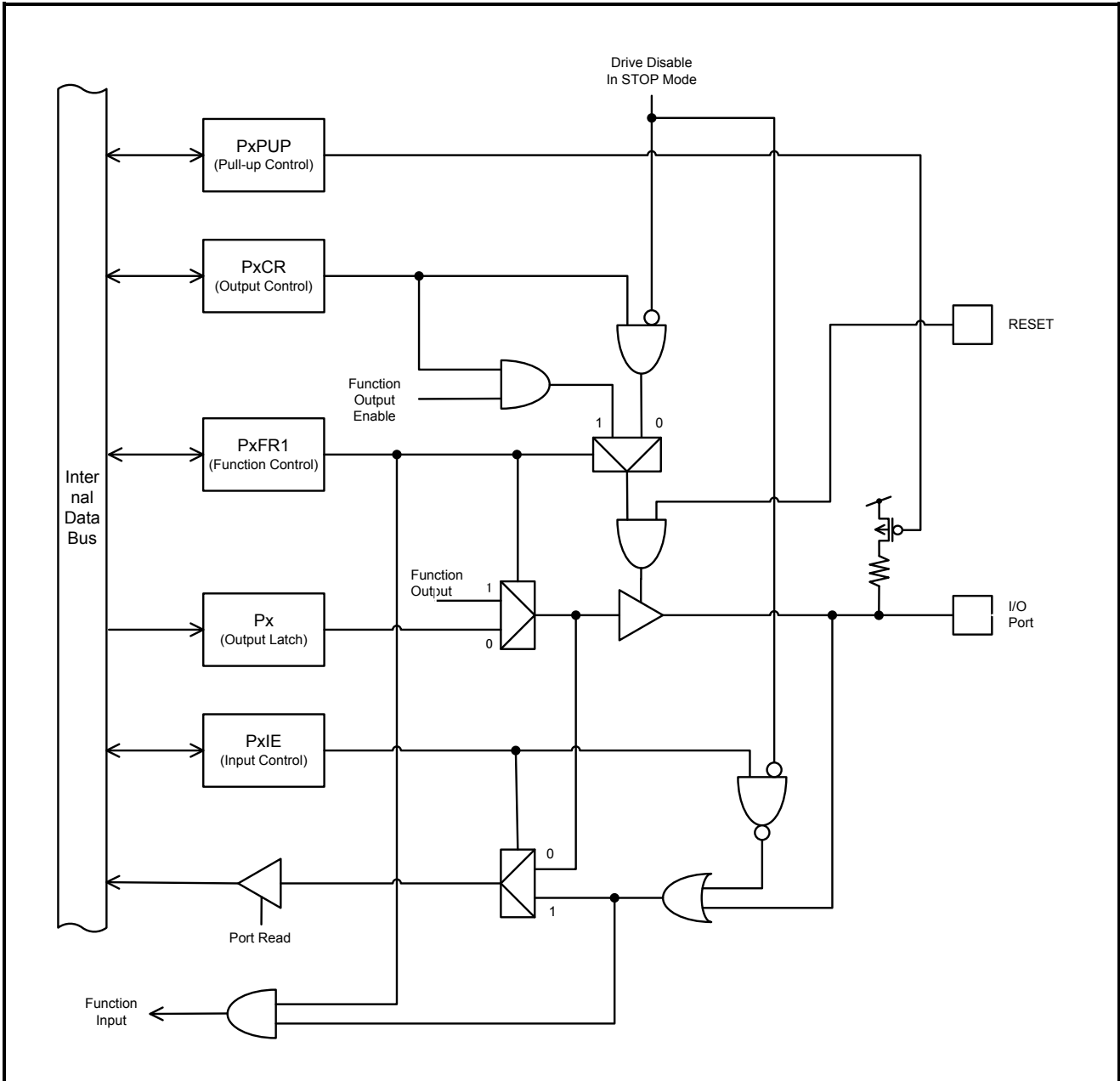

9.3.14 Type T13

Type T13 is a general-purpose input/ output port with pull-up and open drain. It is used to input/output function data as well.

Pull-up and output are disabled during reset.

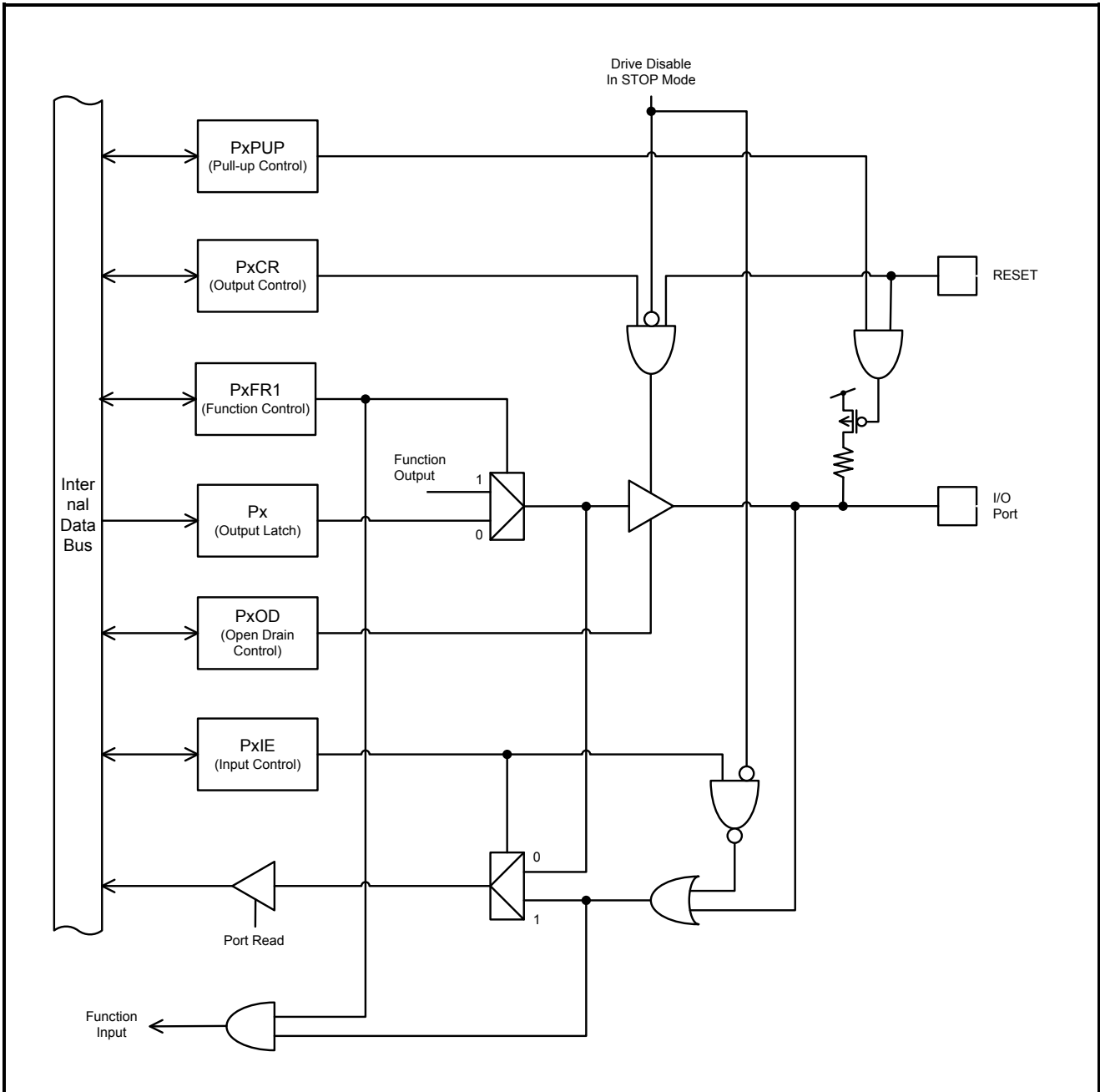

9.3.15 Type T14

Type T14 is a general-purpose input/ output port. It is used to input/output function data as well. Output is disabled during reset.

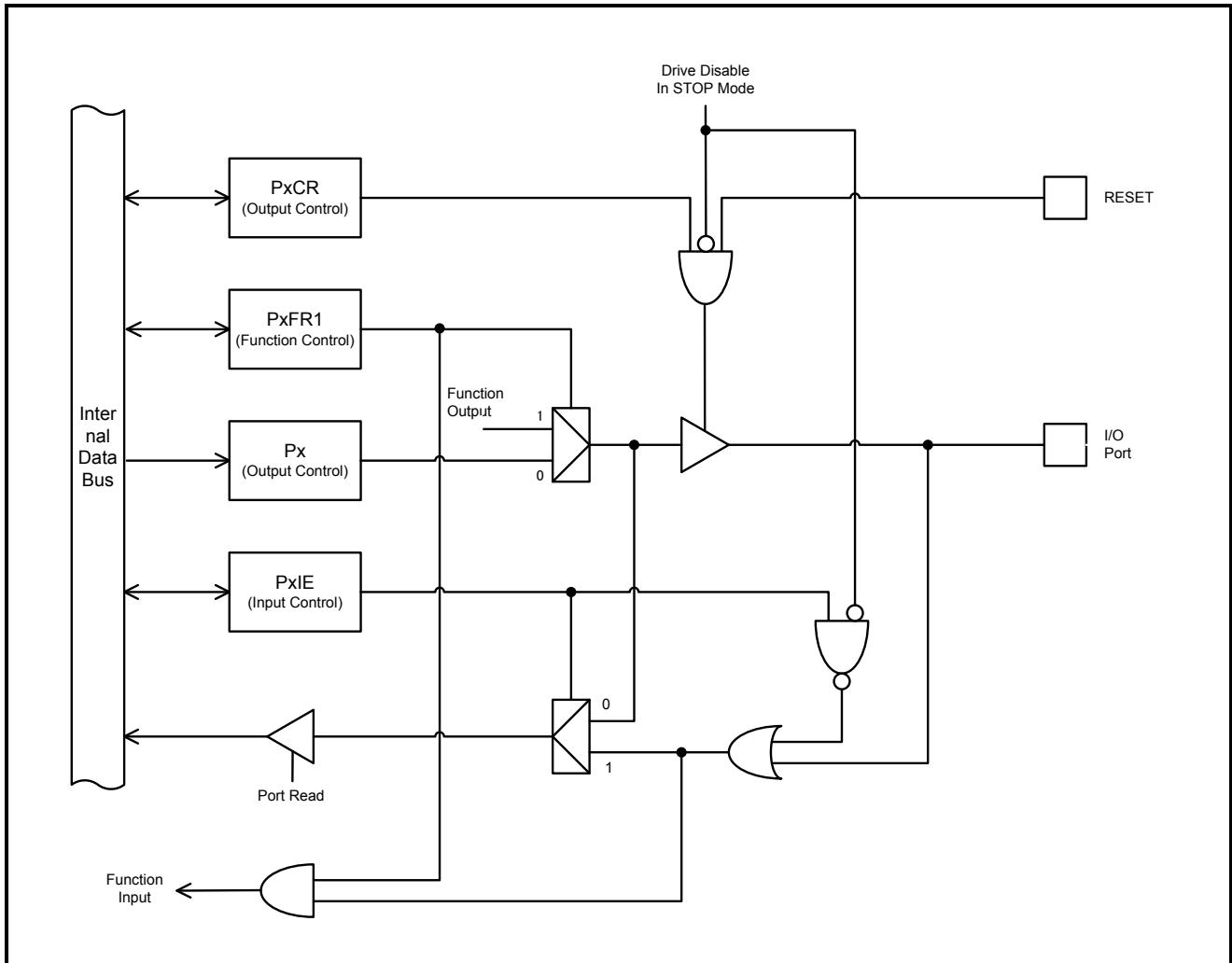

**(Note)** PK0 that uses Type 14 is an Nch open drain port.

9.3.16 Type T15

Type T15 is a general-purpose input/ output port with pull-up. It is used to output two kinds of function data as well.

Pull-up and output are disabled during reset.

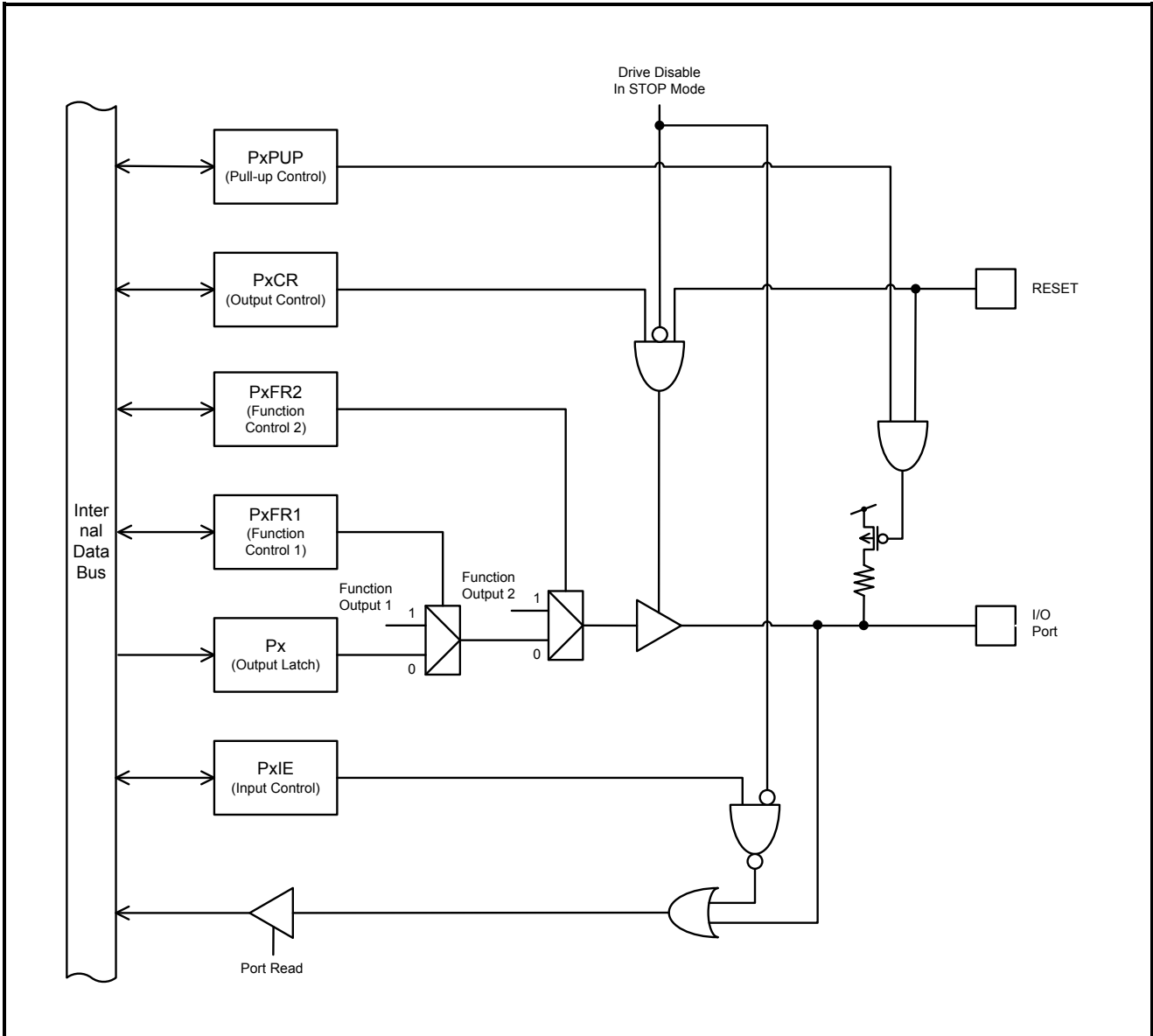

9.3.17 Type T16

Type T16 is a general-purpose input/ output port with pull-up and open drain. It is used to communicate two kinds of function data (function 1: input and output, function 2: input) as well.

Pull-up and output are disabled during reset.

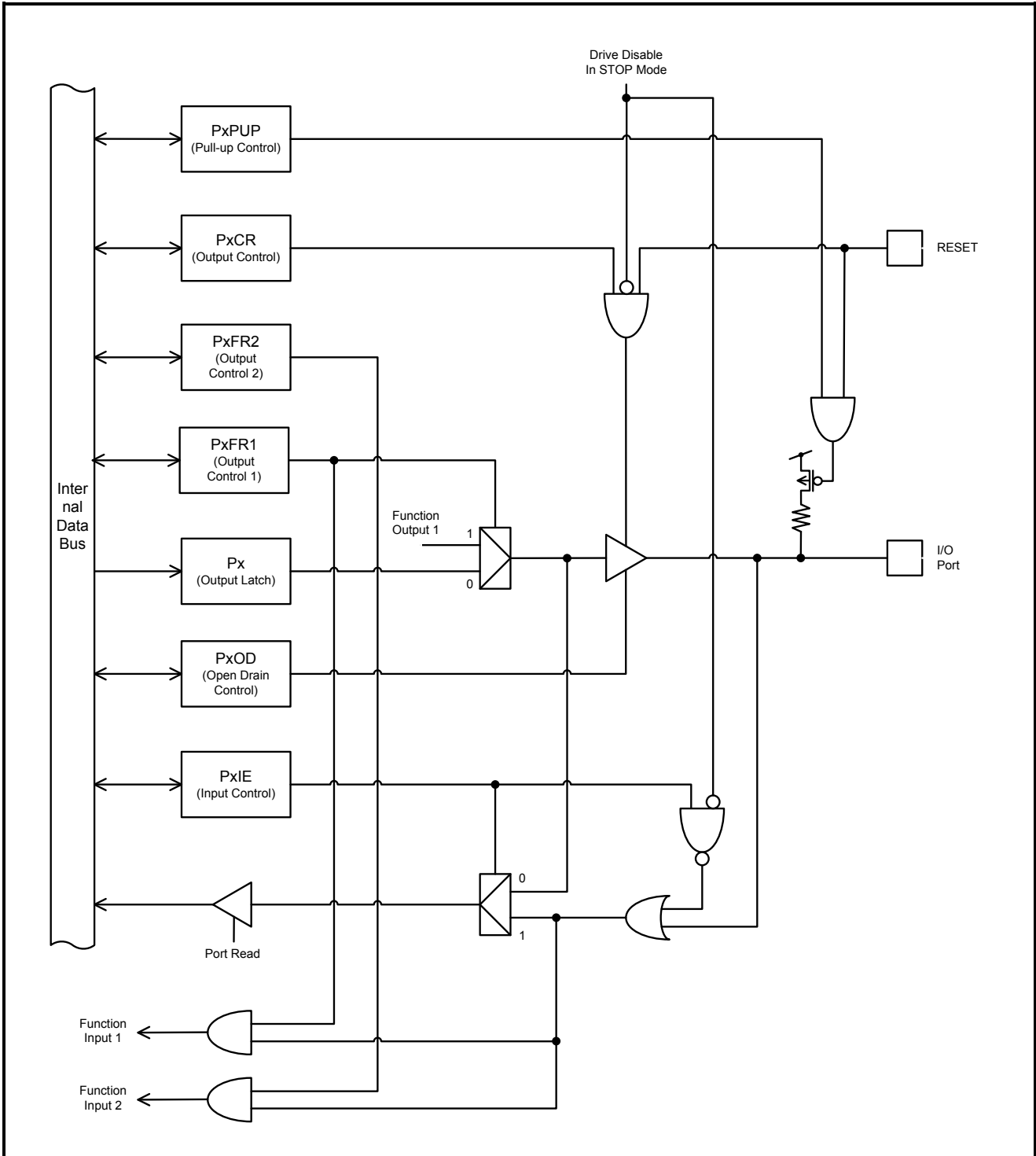

9.3.18 Type T17

Type 17 is a general-purpose input port with pull-up. It is used to input analog signals for A/D converter.

Pull-up is disabled during reset.

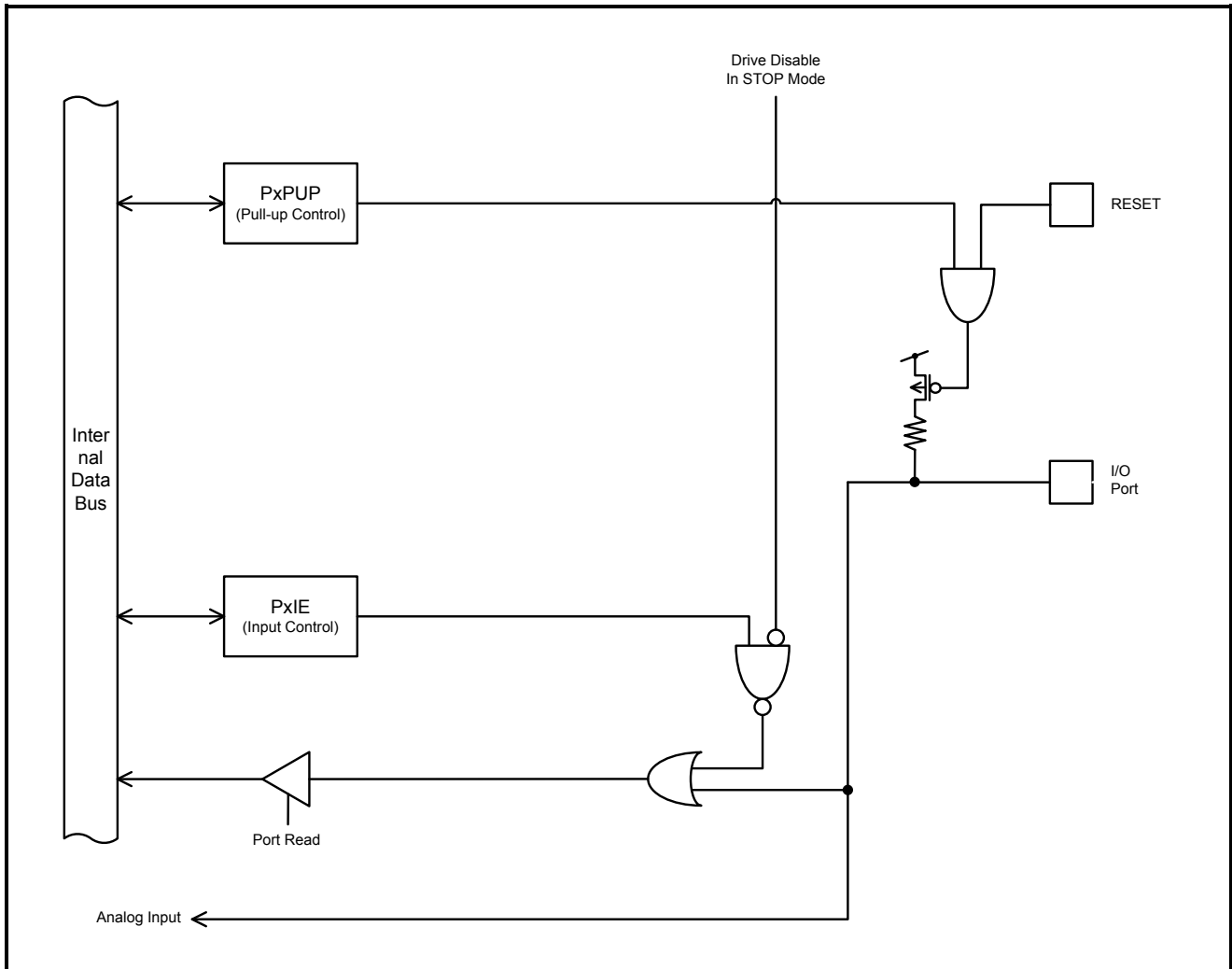

### 9.3.19 Type T18

Type 18 is a general-purpose input port with pull-up. It is used to input function data and analog signals for A/D converter as well.

Pull-up is disabled during reset.

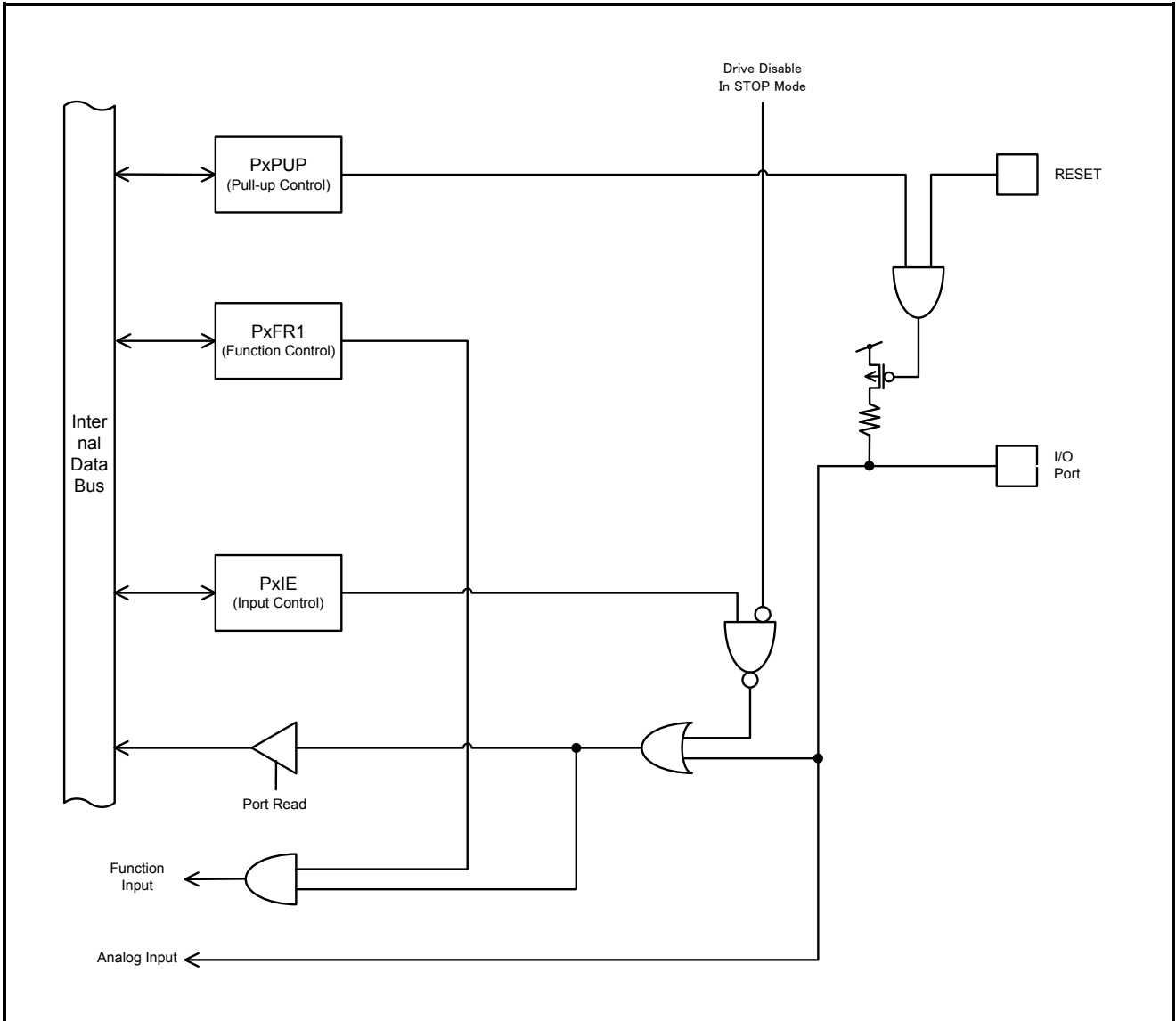

## 10 16-bit Timer/Event Counters (TMRBs)

### 10.1 Outline

Each of the ten channels (TMRB0 through TMRB9) has a multi-functional 16-bit timer/event counter. TMRBs operate in the following four operation modes:

- 16-bit interval timer mode
- 16-bit event counter mode
- 16-bit programmable square-wave output mode (PPG)
- Timer synchronous mode (capable of setting output mode for each 4ch)

The use of the capture function allows TMRBs to perform the following three measurements

- Frequency measurement
- Pulse width measurement
- Time difference measurement

## 10.2 Differences in the Specifications

Each channel (TMRB0 through TMRB9) functions independently and the channels operate in the same way, except for the differences in their specifications as shown in Table 10-1 and Table 10-2 and the two-phase pulse count function. Therefore, the operational descriptions here are only for TMRB0.

The channels shown below are used as the capture or start trigger.

- (1) The flip-flop output of TMRB 7 through TMRB 9 can be used as the capture trigger of other channels.
  - TB7OUT => available for TMRB 0 through TMRB 1
  - TB8OUT => available for TMRB 2 through TMRB 4
  - TB9OUT => available for TMRB 5 through TMRB 6
- (2) The start trigger of the timer synchronous mode (with TBxRUN)
  - TMRB0 => can start TMRB 0 through TMRB 3 synchronously
  - TMRB4 => can start TMRB 4 through TMRB 7 synchronously

Table 10-1 Differences in the Specifications of TMRB Modules (1)

Channel \ Specification	External pins		Trigger	
	External clock/ capture trigger input pins	Timer flip-flop output pin	Timer for capture triggers	Timer for synchronous stat triggers
TMRB0	TB0IN0 (shared with PH0) TB0IN1 (shared with PH1)	TB0OUT (shared with PI0)	TB7OUT	—
TMRB1	TB1IN0 (shared with PH2) TB1IN1 (shared with PH3)	TB1OUT (shared with PI1)	TB7OUT	TB0PRUN, TB0RUN
TMRB2	TB2IN0 (shared with PH4) TB2IN1 (shared with PH5)	TB2OUT (shared with PI2)	TB8OUT	TB0PRUN, TB0RUN
TMRB3	TB3IN0 (shared with PH6) TB3IN1 (shared with PH7)	TB3OUT (shared with PI3)	TB8OUT	TB0PRUN, TB0RUN
TMRB4	TB4IN0 (shared with PI6) TB4IN1 (shared with PI7)	TB4OUT (shared with PI4)	TB8OUT	—
TMRB5	TB5IN0 (shared with PD0) TB5IN1 (shared with PD1)	TB5OUT (shared with PI5)	TB9OUT	TB4PRUN, TB4RUN
TMRB6	TB6IN0 (shared with PD2) TB6IN1 (shared with PD3)	TB6OUT (shared with PJ4)	TB9OUT	TB4PRUN, TB4RUN
TMRB7	—	TB7OUT (shared with PJ5)	—	TB4PRUN, TB4RUN
TMRB8	—	TB8OUT (shared with PG7)	—	—
TMRB9	—	TB9OUT (shared with PK2)	—	—

Table 10-2 Differences in the Specifications of TMRB Modules (2)

Specification Channel	Interrupt	
	Capture interrupt	TMRB interrupt
TMRB0	INTCAP00 INTCAP01	INTTB0
TMRB1	INTCAP10 INTCAP11	INTTB1
TMRB2	INTCAP20 INTCAP21	INTTB2
TMRB3	INTCAP30 INTCAP31	INTTB3
TMRB4	INTCAP40 INTCAP40	INTTB4
TMRB5	INTCAP50 INTCAP51	INTTB5
TMRB6	INTCAP60 INTCAP61	INTTB6
TMRB7	—	INTTB7
TMRB8	—	INTTB8
TMRB9	—	INTTB9

### 10.3 Configuration

Each channel consists of a 16-bit up-counter, two 16-bit timer registers (one of which is double-buffered, except for TBRB0 with one double-buffered 16-bit timer register), two 16-bit capture registers, two comparators, a capture input control, a timer flip-flop and its associated control circuit.

Timer operation modes and the timer flip-flop are controlled by a register.

**(Note 1) TB7OUT is input to channels 0 and 1. TB8OUT is input to channels 2 through 4. TB9OUT is input to channels 5 and 6.**

**(Note 2) Please note that channels 7 through 9:**

- do not output TBxOUT to an external pin.
- do not input TBnIN0 and TBnIN1 from an external pin.
- cannot use capture interrupt of INTCAPn0 and INTCAPn1.

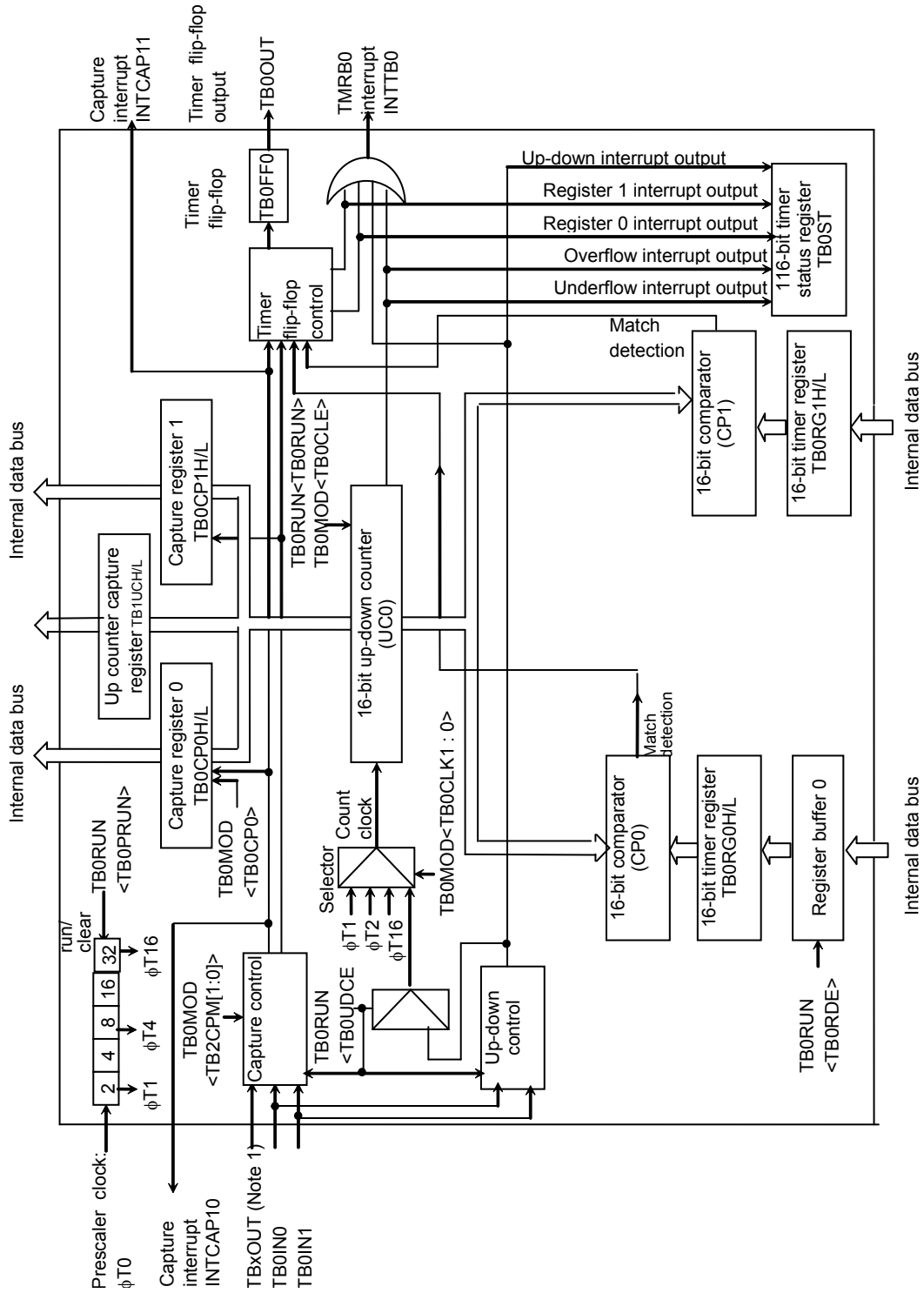

Fig. 10-1 TMRB1 Block Diagram (the same applies to channels 0 and 2 through 9)

## 10.4 Registers

### 10.4.1 TMRB registers

Table 10-3 shows the register names and addresses of each channel.

Table 10-3 TMRB registers (1/2)

Channel		TMRB0		TMRB1		TMRB2		TMRB3	
Specification									
Register names (addresses )	Timer enable register	TB0EN	0x4001_0000	TB1EN	0x4001_0040	TB2EN	0x4001_0080	TB3EN	0x4001_00C0
	Timer RUN register	TB0RUN	0x4001_0004	TB1RUN	0x4001_0044	TB2RUN	0x4001_0084	TB3RUN	0x4001_00C4
	Timer control register	TB0CR	0x4001_0008	TB1CR	0x4001_0048	TB2CR	0x4001_0088	TB3CR	0x4001_00C8
	Timer mode register	TB0MOD	0x4001_000C	TB1MOD	0x4001_004C	TB2MOD	0x4001_008C	TB3MOD	0x4001_00CC
	Timer flip-flop control register	TB0FFCR	0x4001_0010	TB1FFCR	0x4001_0050	TB2FFCR	0x4001_0090	TB3FFCR	0x4001_00D0
	Timer status register	TB0ST	0x4001_0014	TB1ST	0x4001_0054	TB2ST	0x4001_0094	TB3ST	0x4001_00D4
	Interrupt mask register	TB0IM	0x4001_0018	TB1IM	0x4001_0058	TB2IM	0x4001_0098	TB3IM	0x4001_00D8
	Timer up counter register	TB0UC	0x4001_001C	TB1UC	0x4001_005C	TB2UC	0x4001_009C	TB3UC	0x4001_00DC
	Timer register	TB0RG0	0x4001_0020	TB1RG0	0x4001_0060	TB2RG0	0x4001_00A0	TB3RG0	0x4001_00E0
		TB0RG1	0x4001_0024	TB1RG1	0x4001_0064	TB2RG1	0x4001_00A4	TB3RG1	0x4001_00E4
Capture register	TB0CP0	0x4001_0028	TB1CP0	0x4001_0068	TB2CP0	0x4001_00A8	TB3CP0	0x4001_00E8	
	TB0CP1	0x4001_002C	TB1CP1	0x4001_006C	TB2CP1	0x4001_00AC	TB3CP1	0x4001_00EC	

Channel		TMRB4		TMRB5		TMRB6		TMRB7	
Specification									
Register names (addresses )	Timer enable register	TB4EN	0x4001_0100	TB5EN	0x4001_0140	TB6EN	0x4001_0180	TB7EN	0x4001_01C0
	Timer RUN register	TB4RUN	0x4001_0104	TB5RUN	0x4001_0144	TB6RUN	0x4001_0184	TB7RUN	0x4001_01C4
	Timer control register	TB4CR	0x4001_0108	TB5CR	0x4001_0148	TB6CR	0x4001_0188	TB7CR	0x4001_01C8
	Timer mode register	TB4MOD	0x4001_010C	TB5MOD	0x4001_014C	TB6MOD	0x4001_018C	TB7MOD	0x4001_01CC
	Timer flip-flop control register	TB4FFCR	0x4001_0110	TB5FFCR	0x4001_0150	TB6FFCR	0x4001_0190	TB7FFCR	0x4001_01D0
	Timer status register	TB4ST	0x4001_0114	TB5ST	0x4001_0154	TB6ST	0x4001_0194	TB7ST	0x4001_01D4
	Interrupt mask register	TB4IM	0x4001_0118	TB5IM	0x4001_0158	TB6IM	0x4001_0198	TB7IM	0x4001_01D8
	Timer up counter register	TB4UC	0x4001_011C	TB5UC	0x4001_015C	TB6UC	0x4001_019C	TB7UC	0x4001_01DC
	Timer register	TB4RG0	0x4001_0120	TB5RG0	0x4001_0160	TB6RG0	0x4001_01A0	TB7RG0	0x4001_01E0
		TB4RG1	0x4001_0124	TB5RG1	0x4001_0164	TB6RG1	0x4001_01A4	TB7RG1	0x4001_01E4
Capture register	TB4CP0	0x4001_0128	TB5CP0	0x4001_0168	TB6CP0	0x4001_01A8	TB7CP0	0x4001_01E8	
	TB4CP1	0x4001_012C	TB5CP1	0x4001_016C	TB6CP1	0x4001_01AC	TB7CP1	0x4001_01EC	

Table 10-3 TMRB registers (2/2)

Specification		Channel		TMRB8		TMRB9	
Register names (addresses )	Timer enable register	TB8EN	0x4001_0200	TB9EN	0x4001_0240		
	Timer RUN register	TB8RUN	0x4001_0204	TB9RUN	0x4001_0244		
	Timer control register	TB8CR	0x4001_0208	TB9CR	0x4001_0248		
	Timer mode register	TB8MOD	0x4001_020C	TB9MOD	0x4001_024C		
	Timer flip-flop control register	TB8FFCR	0x4001_0210	TB9FFCR	0x4001_0250		
	Timer status register	TB8ST	0x4001_0214	TB9ST	0x4001_0254		
	Interrupt mask register	TB8IM	0x4001_0218	TB9IM	0x4001_0258		
	Timer up counter register	TB8UC	0x4001_021C	TB9UC	0x4001_025C		
	Timer register	TB8RG0	0x4001_0220	TB9RG0	0x4001_0260		
		TB8RG1	0x4001_0224	TB9RG1	0x4001_0264		
	Capture register	TB8CP0	0x4001_0228	TB9CP0	0x4001_0268		
TB8CP1		0x4001_022C	TB9CP1	0x4001_026C			

10.4.1.1 TMRBn enable register (channels 0 through 9)

TMRBn enable register (n=0~9)

	31	30	29	28	27	26	25	24
bit Symbol								
Read/Write	R	R	R	R	R	R	R	R
After reset	0	0	0	0	0	0	0	0
	23	22	21	20	19	18	17	16
bit Symbol								
Read/Write	R	R	R	R	R	R	R	R
After reset	0	0	0	0	0	0	0	0
	15	14	13	12	11	10	9	8
bit Symbol								
Read/Write	R	R	R	R	R	R	R	R
After reset	0	0	0	0	0	0	0	0
	7	6	5	4	3	2	1	0
bit Symbol	TBnEN							
Read/Write	R/W	R						
After reset	0	0						
Function	TMRBn operation 0: Disabled 1: Enabled	"0" is read.						

<TBnEN>: Specifies the TMRB operation. When the operation is disabled, no clock is supplied to the other registers in the TMRB module. This can reduce power consumption. (This disables reading from and writing to the other registers.) To use the TMRB, enable the TMRB operation (set to "1") before programming each register in the TMRB module. If the TMRB operation is executed and then disabled, the settings will be maintained in each register.

10.4.1.2 TMRB RUN register (channels 0 through 9)

TMRBn RUN register (n=0~9)

TBRUN (0x4001_0xx4)		31	30	29	28	27	26	25	24
	bit Symbol	/							
	Read/Write	R	R	R	R	R	R	R	R
	After reset	0	0	0	0	0	0	0	0
		23	22	21	20	19	18	17	16
	bit Symbol	/							
	Read/Write	R	R	R	R	R	R	R	R
	After reset	0	0	0	0	0	0	0	0
		15	14	13	12	11	10	9	8
	bit Symbol	/							
	Read/Write	R	R	R	R	R	R	R	R
	After reset	0	0	0	0	0	0	0	0
	7	6	5	4	3	2	1	0	
bit Symbol	/					TBRUN	/		TBRUN
Read/Write	R					R/W	R	R/W	
After reset	0					0	0	0	
Function	"0" is read.					Timer Run/Stop Control 0: Stop & clear 1: Count * The first bit can be read as "0."			

<TBRUN> :Controls the TMRB0 count operation.

<TBRUNPRUN> :Controls the TMRB0 prescaler operation.

**(Note)** Note : When the counter is stopped (<TBRUN>="0") and TBxUC<TBUC[15:0]> is read, the value which was captured when the counter was operated is read.

10.4.1.3 TMRB control register (channels 0 through 9)

TMRBn control register (n=0~9)

TnCR (0x4001_0xx8)	31	30	29	28	27	26	25	24
	bit Symbol							
	Read/Write	R	R	R	R	R	R	R
	After reset	0	0	0	0	0	0	0
	23	22	21	20	19	18	17	16
	bit Symbol							
	Read/Write	R	R	R	R	R	R	R
	After reset	0	0	0	0	0	0	0
	15	14	13	12	11	10	9	8
	bit Symbol							
Read/Write	R	R	R	R	R	R	R	
After reset	0	0	0	0	0	0	0	
7	6	5	4	3	2	1	0	
bit Symbol	TnWBF		TnSYNC		I2Tn			
Read/Write	R/W	R/W	R/W	R	R/W	R		
After reset	0	0	0	0	0	0		
Function	Double Buffer 0: Disabled 1: Enabled	Write "0".	Timer operation mode 0: individual 1: synchronous	"0" is read.	IDLE 0: Stop 1: Operation	"0" is read.		

<I2Tm>: Controls the operation in the IDLE mode.

<TnSYNC>: Controls operation mode of timers.  
 "0": timers operate individually.  
 "1": timers operate synchronously.

<TmWBF>: Controls the enabling/disabling of double buffering.

10.4.1.4 TMRB mode register (channels 0 through 9)

TMRBn mode register(n=0~9)

TBnMOD  
(0x4001\_0xxC)

	31	30	29	28	27	26	25	24
bit Symbol								
Read/Write	R	R	R	R	R	R	R	R
After reset	0	0	0	0	0	0	0	0
	23	22	21	20	19	18	17	16
bit Symbol								
Read/Write	R	R	R	R	R	R	R	R
After reset	0	0	0	0	0	0	0	0
	15	14	13	12	11	10	9	8
bit Symbol								
Read/Write	R	R	R	R	R	R	R	R
After reset	0	0	0	0	0	0	0	0
	7	6	5	4	3	2	1	0
bit Symbol			TBnCP0	TBnCPM1	TBnCPM0	TBnCLE	TBnCLK1	TBnCLK0
Read/Write	R	R/W	W	R/W				
After reset	0	0	1	0	0	0	0	0
Function	"0" is read.	Write "0".	Capture control by software 0: Capture by software 1: Don't care	Capture timing 00: Disable Capture timing 00: Disable 01: TBnIN0 ↑ TBnIN1 ↑ 10: TBnIN0 ↑ TBnIN1 ↓ 11: TBnOUT ↑ TBnOUT ↓		Up-counter control 0: Clear/disable 1: clear/enable	Selects source clock 00: TBnIN0 pin input 01: φT1 10: φT4 11: φT16	

<TBnCLK[1:0]>:Selects the TMRBn timer count clock.

<TBnCLE>:Clears and controls the TMRBn up-counter.

"0": Disables clearing of the up-counter.

"1": Clears up-counter if there is a match with timer register 1 (TBnRG1).

<TBnCPM[1:0]>:Specifies TMRBn capture timing.

"00": Capture disable

"01": Takes count values into capture register 0 (TBnCP0) upon rising of TBnIN0 pin input.  
Takes count values into capture register 1 (TBnCP1) upon rising of TBnIN1 pin input.

"10": Takes count values into capture register 0 (TBnCP0) upon rising of TBnIN0 pin input.  
Takes count values into capture register 1 (TBnCP1) upon falling of TBnIN0 pin input.

"11":Takes count values into capture register 0 (TBnCP0) upon rising of 16-bit timer match output (TBxOUT) and into capture register 1 (TBnCP1) upon falling of TBxOUT (TMRB0 and TMRB1:TB7OUT, TMRB2 through TMRB4:TB8OUT, TMRB5 and TMRB6:TB9OUT).

<TBnCP0>:Captures count values by software and takes them into capture register 0 (TBnCP0).

**(Note 1)** The value read from bit 5 of TBnMOD is "1".

**(Note 2)** Input from TBnIN0 and TBnIN1 is available only for channels TMRB0 through 6.

10.4.1.5 TMRB flip-flop control register (channels 0 through 9)

TMRBn flip-flop control register (n=0~9)

TnFFCR (0x4001_0xx0)	TMRBn flip-flop control register (n=0~9)								
	bit Symbol	31	30	29	28	27	26	25	24
	Read/Write	R	R	R	R	R	R	R	R
	After reset	0	0	0	0	0	0	0	0
	bit Symbol	23	22	21	20	19	18	17	16
	Read/Write	R	R	R	R	R	R	R	R
	After reset	0	0	0	0	0	0	0	0
	bit Symbol	15	14	13	12	11	10	9	8
	Read/Write	R	R	R	R	R	R	R	R
	After reset	0	0	0	0	0	0	0	0
	bit Symbol	7	6	5	4	3	2	1	0
	Read/Write	R		R/W				R/W	
After reset	1	1	0	0	0	0	1	1	
Function	"11" is read.		TBnFF0 reverse trigger 0: Disable trigger 1: Enable trigger When the up-counter value is taken into TBnCP1    When the up-counter value is taken into TBnCP0    When the up-counter matches TBnRG1    When the up-counter matches TBnRG0				TBnFF0 control 00: Invert 01: Set 10: Clear 11: Don't care * This is always read as "11."		

<TBnFF0C[1:0]>:Controls the timer flip-flop.

"00": Reverses the value of TBnFF0 (reverse by using software).

"01": Sets TBnFF0 to "1".

"10": Clears TBnFF0 to "0".

"11":Don't care

<TBnE[1:0]>:Reverses the timer flip-flop when the up-counter matches the timer register 0,1 (TBnRG0,1).

<TBnC[1:0]>:Reverses the timer flip-flop when the up-counter value is taken into the capture register 0,1 (TBnCP0,1).

10.4.1.6 TMRB status register (channels 0 through 9)

TMRBn status register (n=0~9)

	31	30	29	28	27	26	25	24
bit Symbol								
Read/Write	R	R	R	R	R	R	R	R
After reset	0	0	0	0	0	0	0	0
	23	22	21	20	19	18	17	16
bit Symbol								
Read/Write	R	R	R	R	R	R	R	R
After reset	0	0	0	0	0	0	0	0
	15	14	13	12	11	10	9	8
bit Symbol								
Read/Write	R	R	R	R	R	R	R	R
After reset	0	0	0	0	0	0	0	0
	7	6	5	4	3	2	1	0
bit Symbol						INTTBOFn	INTTBn1	INTTBn0
Read/Write	R					R		
After reset	0					0	0	0
Function	"0" is read.					0: Interrupt not generated 1: Interrupt generated	0: Interrupt not generated 1: Interrupt generated	0: Interrupt not generated 1: Interrupt generated

<INTTBn0>:Interrupt generated if there is a match with timer register 0 (TBnRG0)

<INTTBn1>:Interrupt generated if there is a match with timer register 1 (TBnRG1)

<INTTBOFn>:Interrupt generated if an up-counter overflow occurs

**(Note1)** The factors only which is not masked by TBnIM output request to the CPU. Even if the mask setting is done, the flag is set.  
**(Note2)** The flag is cleared by reading the TBnST register. To clear the flag, TBnST register should be read.

10.4.1.7 TMRB interrupt mask register (channels 0 through 9)

TMRBn interrupt mask register (n=0~9)

TBnIM  
(0x4001\_0xx8)

	31	30	29	28	27	26	25	24
bit Symbol								
Read/Write	R	R	R	R	R	R	R	R
After reset	0	0	0	0	0	0	0	0
	23	22	21	20	19	18	17	16
bit Symbol								
Read/Write	R	R	R	R	R	R	R	R
After reset	0	0	0	0	0	0	0	0
	15	14	13	12	11	10	9	8
bit Symbol								
Read/Write	R	R	R	R	R	R	R	R
After reset	0	0	0	0	0	0	0	0
	7	6	5	4	3	2	1	0
bit Symbol						TBIMOFn	TBIMn1	TBIMn0
Read/Write	R					R/W		
After reset	0					0	0	0
Function	"0" is read					1: Interrupt is masked	1: Interrupt is masked	1: Interrupt is masked

<TBIMn0> : Interrupt is masked if there is a match with timer register 0 (TBnRG0)

<TBIMn1> :Interrupt is masked if there is a match with timer register 1 (TBnRG1).

<TBIMOFn> :Interrupt is masked if an up-and-down counter overflow occurs.

10.4.1.8 TMRB read capture register (channels 0 through 9)

TBnUC read capture register (n=0~9)

TBnUC  
(0x4001\_0xxC)

	31	30	29	28	27	26	25	24
bit Symbol								
Read/Write	R	R	R	R	R	R	R	R
After reset	0	0	0	0	0	0	0	0
	23	22	21	20	19	18	17	16
bit Symbol								
Read/Write	R	R	R	R	R	R	R	R
After reset	0	0	0	0	0	0	0	0
	15	14	13	12	11	10	9	8
bit Symbol	UCn15	UCn14	UCn13	UCn12	UCn11	UCn10	UCn9	UCn8
Read/Write	R							
After reset	0							
Function	Data obtained by read capture: 15-8 bit data							
	7	6	5	4	3	2	1	0
bit Symbol	UCn7	UCn6	UCn5	UCn4	UCn3	UCn2	UCn1	UCn0
Read/Write	R							
After reset	0							
Function	Data obtained by read capture: 7-0 bit							

**(Note)** When the counter is operated and TBxUC is read, the value of the up counter is captured and read.

10.4.1.9 TMRB timer register (channels 0 through 9)

TBnRG0 timer register (n=0~9)

TBnRG0  
(0x4001\_0xx0)

	31	30	29	28	27	26	25	24
bit Symbol								
Read/Write	R	R	R	R	R	R	R	R
After reset	0	0	0	0	0	0	0	0
	23	22	21	20	19	18	17	16
bit Symbol								
Read/Write	R	R	R	R	R	R	R	R
After reset	0	0	0	0	0	0	0	0
	15	14	13	12	11	10	9	8
bit Symbol	TBnRG01 5	TBnRG01 4	TBnRG01 3	TBnRG01 2	TBnRG01 1	TBnRG01 0	TBnRG09	TBnRG08
Read/Write	R/W							
After reset	0							
Function	Timer count value: 15-8 bit data							
	7	6	5	4	3	2	1	0
bit Symbol	TBnRG07	TBnRG06	TBnRG05	TBnRG04	TBnRG03	TBnRG02	TBnRG01	TBnRG00
Read/Write	R/W							
After reset	0							
Function	Timer count value: 7-0 bit data							

TBnRG1 timer register (n=0~9)

TBnRG1  
(0x4001\_0xx4)

	31	30	29	28	27	26	25	24
bit Symbol								
Read/Write	R	R	R	R	R	R	R	R
After reset	0	0	0	0	0	0	0	0
	23	22	21	20	19	18	17	16
bit Symbol								
Read/Write	R	R	R	R	R	R	R	R
After reset	0	0	0	0	0	0	0	0
	15	14	13	12	11	10	9	8
bit Symbol	TBnRG11 5	TBnRG11 4	TBnRG11 3	TBnRG11 2	TBnRG11 1	TBnRG11 0	TBnRG19	TBnRG18
Read/Write	R/W							
After reset	0							
Function	Timer count value: 15-8 bit data							
	7	6	5	4	3	2	1	0
bit Symbol	TBnRG17	TBnRG16	TBnRG15	TBnRG14	TBnRG13	TBnRG12	TBnRG11	TBnRG10
Read/Write	R/W							
After reset	0							
Function	Timer count value: 7-0 bit data							

10.4.1.10 TMRB capture register (channels 0 through 9)

TBnCP0capture register (n=0~9)

TBnCP0 (0x4001_0xx8)		31	30	29	28	27	26	25	24
	bit Symbol								
	Read/Write	R	R	R	R	R	R	R	R
	After reset	0	0	0	0	0	0	0	0
		23	22	21	20	19	18	17	16
	bit Symbol								
	Read/Write	R	R	R	R	R	R	R	R
	After reset	0	0	0	0	0	0	0	0
		15	14	13	12	11	10	9	8
	bit Symbol	TBnCP01 5	TBnCP01 4	TBnCP01 3	TBnCP01 2	TBnCP01 1	TBnCP01 0	TBnCP09	TBnCP08
	Read/Write	R							
	After reset	Undefined							
	Function	Timer capture value: 15-8 bit data							
		7	6	5	4	3	2	1	0
	bit Symbol	TBnCP07	TBnCP06	TBnCP05	TBnCP04	TBnCP03	TBnCP02	TBnCP01	TBnCP00
	Read/Write	R							
	After reset	Undefined							
	Function	Timer capture value: 7-0 bit data							

TBnCP1 capture register (n=0~9)

TBnCP1 (0x4001_0xxC)		31	30	29	28	27	26	25	24
	bit Symbol								
	Read/Write	R	R	R	R	R	R	R	R
	After reset	0	0	0	0	0	0	0	0
		23	22	21	20	19	18	17	16
	bit Symbol								
	Read/Write	R	R	R	R	R	R	R	R
	After reset	0	0	0	0	0	0	0	0
		15	14	13	12	11	10	9	8
	bit Symbol	TBnCP11 5	TBnCP11 4	TBnCP11 3	TBnCP11 2	TBnCP11 1	TBnCP11 0	TBnCP19	TBnCP18
	Read/Write	R							
	After reset	Undefined							
	Function	Timer capture value: 15-8 bit data							
		7	6	5	4	3	2	1	0
	bit Symbol	TBnCP17	TBnCP16	TBnCP15	TBnCP14	TBnCP13	TBnCP12	TBnCP11	TBnCP10
	Read/Write	R							
	After reset	Undefined							
	Function	Timer capture value: 7-0 bit data							

## 10.5 Description of Operations for Each Circuit

The channels operate in the same way, except for the differences in their specifications as shown in Table 10-1 and Table 10-2. Therefore, the operational descriptions here are only for channel 0.

### 10.5.1 Prescaler

There is a 4-bit prescaler to generate the source clock for up-counter UC0. The prescaler input clock  $\phi T0$  is  $f_{\text{periph}}/1$ ,  $f_{\text{periph}}/2$ ,  $f_{\text{periph}}/4$ ,  $f_{\text{periph}}/8$ ,  $f_{\text{periph}}/16$  or  $f_{\text{periph}}/32$  selected by CGSYSCR<PRCK[2:0]> in the CG. The peripheral clock,  $f_{\text{periph}}$ , is either  $f_{\text{gear}}$ , a clock selected by CGSYSCR<FPSEL> in the CG, or  $f_c$ , which is a clock before it is divided by the clock gear.

The operation or the stoppage of a prescaler is set with TB0RUN<TB0PRUN> where writing "1" starts counting and writing "0" clears and stops counting. Table 10-4 and Table 10-5 show prescaler output clock resolutions.

Table 10-4 Prescaler Output Clock Resolutions @fc = 40MHz

Release peripheral clock <FPSEL>	Clock gear value <GEAR[2:0]>	Select prescaler clock <PRCK[1:0]>	Prescaler output clock resolutions		
			$\phi T1$	$\phi T4$	$\phi T16$
0 (fgear)	000 (fc)	000(fperiph/1)	$fc/2^1(0.05\mu s)$	$fc/2^3(0.2\mu s)$	$fc/2^5(0.8\mu s)$
		001(fperiph/2)	$fc/2^2(0.1\mu s)$	$fc/2^4(0.4\mu s)$	$fc/2^6(1.6\mu s)$
		010(fperiph/4)	$fc/2^3(0.2\mu s)$	$fc/2^5(0.8\mu s)$	$fc/2^7(3.2\mu s)$
		011(fperiph/8)	$fc/2^4(0.4\mu s)$	$fc/2^6(1.6\mu s)$	$fc/2^8(6.4\mu s)$
		100(fperiph/16)	$fc/2^5(0.8(s))$	$fc/27(3.2(s))$	$fc/29(12.8(s))$
		101(fperiph/32)	$fc/2^6(1.6\mu s)$	$fc/2^8(6.4\mu s)$	$fc/2^{10}(25.6\mu s)$
	100(fc/2)	000(fperiph/1)	$fc/2^2(0.1\mu s)$	$fc/2^4(0.4\mu s)$	$fc/2^6(1.6\mu s)$
		001(fperiph/2)	$fc/2^3(0.2\mu s)$	$fc/2^5(0.8\mu s)$	$fc/2^7(3.2\mu s)$
		010(fperiph/4)	$fc/2^4(0.4\mu s)$	$fc/2^6(1.6\mu s)$	$fc/2^8(6.4\mu s)$
		011(fperiph/8)	$fc/2^5(0.8\mu s)$	$fc/2^7(3.2\mu s)$	$fc/2^9(12.8\mu s)$
		100(fperiph/16)	$fc/2^6(1.6\mu s)$	$fc/2^8(6.4\mu s)$	$fc/2^{10}(25.6\mu s)$
		101(fperiph/32)	$fc/2^7(3.2\mu s)$	$fc/2^9(12.8\mu s)$	$fc/2^{11}(51.2\mu s)$
	101(fc/4)	000(fperiph/1)	$fc/2^3(0.2\mu s)$	$fc/2^5(0.8\mu s)$	$fc/2^7(3.2\mu s)$
		001(fperiph/2)	$fc/2^4(0.4\mu s)$	$fc/2^6(1.6\mu s)$	$fc/2^8(6.4\mu s)$
		010(fperiph/4)	$fc/2^5(0.8\mu s)$	$fc/2^7(3.2\mu s)$	$fc/2^9(12.8\mu s)$
		011(fperiph/8)	$fc/2^6(1.6\mu s)$	$fc/2^8(6.4\mu s)$	$fc/2^{10}(25.6\mu s)$
		100(fperiph/16)	$fc/2^7(3.2\mu s)$	$fc/2^9(12.8\mu s)$	$fc/2^{11}(51.2\mu s)$
		101(fperiph/32)	$fc/2^8(6.4\mu s)$	$fc/2^{10}(25.6\mu s)$	$fc/2^{12}(102.4\mu s)$
	110(fc/8)	000(fperiph/1)	$fc/2^4(0.4\mu s)$	$fc/2^6(1.6\mu s)$	$fc/2^8(6.4\mu s)$
		001(fperiph/2)	$fc/2^5(0.8\mu s)$	$fc/2^7(3.2\mu s)$	$fc/2^9(12.8\mu s)$
		010(fperiph/4)	$fc/2^6(1.6\mu s)$	$fc/2^8(6.4\mu s)$	$fc/2^{10}(25.6\mu s)$
		011(fperiph/8)	$fc/2^7(3.2\mu s)$	$fc/2^9(12.8\mu s)$	$fc/2^{11}(51.2\mu s)$
		100(fperiph/16)	$fc/2^8(6.4\mu s)$	$fc/2^{10}(25.6\mu s)$	$fc/2^{12}(102.4\mu s)$
		101(fperiph/32)	$fc/2^9(12.8\mu s)$	$fc/2^{11}(51.2\mu s)$	$fc/2^{13}(204.8\mu s)$
1 (fc)	000 (fc)	000(fperiph/1)	$fc/2^1(0.05\mu s)$	$fc/2^3(0.2\mu s)$	$fc/2^5(0.8\mu s)$
		001(fperiph/2)	$fc/2^2(0.1\mu s)$	$fc/2^4(0.4\mu s)$	$fc/2^6(1.6\mu s)$
		010(fperiph/4)	$fc/2^3(0.2\mu s)$	$fc/2^5(0.8\mu s)$	$fc/2^7(3.2\mu s)$
		011(fperiph/8)	$fc/2^4(0.4\mu s)$	$fc/2^6(1.6\mu s)$	$fc/2^8(6.4\mu s)$
		100(fperiph/16)	$fc/2^5(0.8\mu s)$	$fc/2^7(3.2\mu s)$	$fc/2^9(12.8\mu s)$
		101(fperiph/32)	$fc/2^6(1.6\mu s)$	$fc/2^8(6.4\mu s)$	$fc/2^{10}(25.6\mu s)$
	100(fc/2)	000(fperiph/1)	—	$fc/2^3(0.2\mu s)$	$fc/2^5(0.8\mu s)$
		001(fperiph/2)	$fc/2^2(0.1\mu s)$	$fc/2^4(0.4\mu s)$	$fc/2^6(1.6\mu s)$
		010(fperiph/4)	$fc/2^3(0.2\mu s)$	$fc/2^5(0.8\mu s)$	$fc/2^7(3.2\mu s)$
		011(fperiph/8)	$fc/2^4(0.4\mu s)$	$fc/2^6(1.6\mu s)$	$fc/2^8(6.4\mu s)$
		100(fperiph/16)	$fc/2^5(0.8\mu s)$	$fc/2^7(3.2\mu s)$	$fc/2^9(12.8\mu s)$
		101(fperiph/32)	$fc/2^6(1.6\mu s)$	$fc/2^8(6.4\mu s)$	$fc/2^{10}(25.6\mu s)$
	101(fc/4)	000(fperiph/1)	—	$fc/2^3(0.2\mu s)$	$fc/2^5(0.8\mu s)$
		001(fperiph/2)	—	$fc/2^4(0.4\mu s)$	$fc/2^6(1.6\mu s)$
		010(fperiph/4)	$fc/2^3(0.2\mu s)$	$fc/2^5(0.8\mu s)$	$fc/2^7(3.2\mu s)$
		011(fperiph/8)	$fc/2^4(0.4\mu s)$	$fc/2^6(1.6\mu s)$	$fc/2^8(6.4\mu s)$
		100(fperiph/16)	$fc/2^5(0.8\mu s)$	$fc/2^7(3.2\mu s)$	$fc/2^9(12.8\mu s)$
		101(fperiph/32)	$fc/2^6(1.6\mu s)$	$fc/2^8(6.4\mu s)$	$fc/2^{10}(25.6\mu s)$
	110(fc/8)	000(fperiph/1)	—	—	$fc/2^5(0.8\mu s)$
		001(fperiph/2)	—	$fc/2^4(0.4\mu s)$	$fc/2^6(1.6\mu s)$
		010(fperiph/4)	—	$fc/2^5(0.8\mu s)$	$fc/2^7(3.2\mu s)$
		011(fperiph/8)	$fc/2^4(0.4\mu s)$	$fc/2^6(1.6\mu s)$	$fc/2^8(6.4\mu s)$
		100(fperiph/16)	$fc/2^5(0.8\mu s)$	$fc/2^7(3.2\mu s)$	$fc/2^9(12.8\mu s)$
		101(fperiph/32)	$fc/2^6(1.6\mu s)$	$fc/2^8(6.4\mu s)$	$fc/2^{10}(25.6\mu s)$

- |          |  |
|----------|--|
| (Note 1) | The prescaler output clock $\phi T_n$ must be selected so that $\phi T_n < f_{sys}$ is satisfied (so that $\phi T_n$ is slower than $f_{sys}$ ). |
| (Note 2) | Do not change the clock gear while the timer is operating.   |
| (Note 3) | “—“ denotes a setting prohibited.  |

Table 10-5 Prescaler Output Clock Resolutions @ = 32MHz

Release peripheral clock <FPSEL>	Clock gear value <GEAR[2:0]>	Select prescaler clock <PRCK[2:0]>	Prescaler output clock resolutions		
			$\phi T1$	$\phi T4$	$\phi T16$
0 (fgear)	000 (fc)	000(fperiph/1)	$fc/2^1(0.0625\mu s)$	$fc/2^3(0.25\mu s)$	$fc/2^5(1.0\mu s)$
		001(fperiph/2)	$fc/2^2(0.125\mu s)$	$fc/2^4(0.5\mu s)$	$fc/2^6(2.0\mu s)$
		010(fperiph/4)	$fc/2^3(0.25\mu s)$	$fc/2^5(1.0\mu s)$	$fc/2^7(4.0\mu s)$
		011(fperiph/8)	$fc/2^4(0.5\mu s)$	$fc/2^6(2.0\mu s)$	$fc/2^8(8.0\mu s)$
		100(fperiph/16)	$fc/2^5(1.0\mu s)$	$fc/2^7(4.0\mu s)$	$fc/2^9(16.0\mu s)$
		101(fperiph/32)	$fc/2^6(2.0\mu s)$	$fc/2^8(8.0\mu s)$	$fc/2^{10}(32.0\mu s)$
	100(fc/2)	000(fperiph/1)	$fc/2^2(0.125\mu s)$	$fc/2^4(0.5\mu s)$	$fc/2^6(2.0\mu s)$
		001(fperiph/2)	$fc/2^3(0.25\mu s)$	$fc/2^5(1.0\mu s)$	$fc/2^7(4.0\mu s)$
		010(fperiph/4)	$fc/2^4(0.5\mu s)$	$fc/2^6(2.0\mu s)$	$fc/2^8(8.0\mu s)$
		011(fperiph/8)	$fc/2^5(1.0\mu s)$	$fc/2^7(4.0\mu s)$	$fc/2^9(16.0\mu s)$
		100(fperiph/16)	$fc/2^6(2.0\mu s)$	$fc/2^8(8.0\mu s)$	$fc/2^{10}(32.0\mu s)$
		101(fperiph/32)	$fc/2^7(4.0\mu s)$	$fc/2^9(16.0\mu s)$	$fc/2^{11}(64.0\mu s)$
	101(fc/4)	000(fperiph/1)	$fc/2^3(0.25\mu s)$	$fc/2^5(1.0\mu s)$	$fc/2^7(4.0\mu s)$
		001(fperiph/2)	$fc/2^4(0.5\mu s)$	$fc/2^6(2.0\mu s)$	$fc/2^8(8.0\mu s)$
		010(fperiph/4)	$fc/2^5(1.0\mu s)$	$fc/2^7(4.0\mu s)$	$fc/2^9(16.0\mu s)$
		011(fperiph/8)	$fc/2^6(2.0\mu s)$	$fc/2^8(8.0\mu s)$	$fc/2^{10}(32.0\mu s)$
		100(fperiph/16)	$fc/2^7(4.0\mu s)$	$fc/2^9(16.0\mu s)$	$fc/2^{11}(64.0\mu s)$
		101(fperiph/32)	$fc/2^8(8.0\mu s)$	$fc/2^{10}(32.0\mu s)$	$fc/2^{12}(128.0\mu s)$
	110(fc/8)	000(fperiph/1)	$fc/2^4(0.5\mu s)$	$fc/2^6(2.0\mu s)$	$fc/2^8(8.0\mu s)$
		001(fperiph/2)	$fc/2^5(1.0\mu s)$	$fc/2^7(4.0\mu s)$	$fc/2^9(16.0\mu s)$
		010(fperiph/4)	$fc/2^6(2.0\mu s)$	$fc/2^8(8.0\mu s)$	$fc/2^{10}(32.0\mu s)$
		011(fperiph/8)	$fc/2^7(4.0\mu s)$	$fc/2^9(16.0\mu s)$	$fc/2^{11}(64.0\mu s)$
		100(fperiph/16)	$fc/2^8(8.0\mu s)$	$fc/2^{10}(32.0\mu s)$	$fc/2^{12}(128.0\mu s)$
		101(fperiph/32)	$fc/2^9(16.0\mu s)$	$fc/2^{11}(64.0\mu s)$	$fc/2^{13}(256.0\mu s)$
1 (fc)	000 (fc)	000(fperiph/1)	$fc/2^1(0.0625\mu s)$	$fc/2^3(0.25\mu s)$	$fc/2^5(1.0\mu s)$
		001(fperiph/2)	$fc/2^2(0.125\mu s)$	$fc/2^4(0.5\mu s)$	$fc/2^6(2.0\mu s)$
		010(fperiph/4)	$fc/2^3(0.25\mu s)$	$fc/2^5(1.0\mu s)$	$fc/2^7(4.0\mu s)$
		011(fperiph/8)	$fc/2^4(0.5\mu s)$	$fc/2^6(2.0\mu s)$	$fc/2^8(8.0\mu s)$
		100(fperiph/16)	$fc/2^5(1.0\mu s)$	$fc/2^7(4.0\mu s)$	$fc/2^9(16.0\mu s)$
		101(fperiph/32)	$fc/2^6(2.0\mu s)$	$fc/2^8(8.0\mu s)$	$fc/2^{10}(32.0\mu s)$
	100(fc/2)	000(fperiph/1)	—	$fc/2^3(0.25\mu s)$	$fc/2^5(1.0\mu s)$
		001(fperiph/2)	$fc/2^2(0.125\mu s)$	$fc/2^4(0.5\mu s)$	$fc/2^6(2.0\mu s)$
		010(fperiph/4)	$fc/2^3(0.25\mu s)$	$fc/2^5(1.0\mu s)$	$fc/2^7(4.0\mu s)$
		011(fperiph/8)	$fc/2^4(0.5\mu s)$	$fc/2^6(2.0\mu s)$	$fc/2^8(8.0\mu s)$
		100(fperiph/16)	$fc/2^5(1.0\mu s)$	$fc/2^7(4.0\mu s)$	$fc/2^9(16.0\mu s)$
		101(fperiph/32)	$fc/2^6(2.0\mu s)$	$fc/2^8(8.0\mu s)$	$fc/2^{10}(32.0\mu s)$
	101(fc/4)	000(fperiph/1)	—	$fc/2^3(0.25\mu s)$	$fc/2^5(1.0\mu s)$
		001(fperiph/2)	—	$fc/2^4(0.5\mu s)$	$fc/2^6(2.0\mu s)$
		010(fperiph/4)	$fc/2^3(0.25\mu s)$	$fc/2^5(1.0\mu s)$	$fc/2^7(4.0\mu s)$
		011(fperiph/8)	$fc/2^4(0.5\mu s)$	$fc/2^6(2.0\mu s)$	$fc/2^8(8.0\mu s)$
		100(fperiph/16)	$fc/2^5(1.0\mu s)$	$fc/2^7(4.0\mu s)$	$fc/2^9(16.0\mu s)$
		101(fperiph/32)	$fc/2^6(2.0\mu s)$	$fc/2^8(8.0\mu s)$	$fc/2^{10}(32.0\mu s)$
	110(fc/8)	000(fperiph/1)	—	—	$fc/2^5(1.0\mu s)$
		001(fperiph/2)	—	$fc/2^4(0.5\mu s)$	$fc/2^6(2.0\mu s)$
		010(fperiph/4)	—	$fc/2^5(1.0\mu s)$	$fc/2^7(4.0\mu s)$
		011(fperiph/8)	$fc/2^4(0.5\mu s)$	$fc/2^6(2.0\mu s)$	$fc/2^8(8.0\mu s)$
		100(fperiph/16)	$fc/2^5(1.0\mu s)$	$fc/2^7(4.0\mu s)$	$fc/2^9(16.0\mu s)$
		101(fperiph/32)	$fc/2^6(2.0\mu s)$	$fc/2^8(8.0\mu s)$	$fc/2^{10}(32.0\mu s)$

- (Note 1) The prescaler output clock  $\phi T_n$  must be selected so that  $\phi T_n < f_{sys}$  is satisfied (so that  $\phi T_n$  is slower than  $f_{sys}$ ).
- (Note 2) Do not change the clock gear while the timer is operating.
- (Note 3) “—” denotes a setting prohibited.

### 10.5.2 Up-counter (UC0)

UC0 is a 16-bit binary counter.

- Source clock

UC0 source clock, specified by TB0MOD<TB0CLK[1:0]>, can be selected from either three types -  $\phi T1$ ,  $\phi T4$  and  $\phi T16$  - of prescaler output clock or the external clock of the TB0IN0 pin.

- Count start/ stop

Counter operation is specified by TB0RUN<TB0RUN>. UC0 starts counting if <TB0RUN> = "1", and stops counting and clears counter value if <TB0RUN> = "0".

- Timing to clear UC0

1) When a match is detected

By setting TB0MOD<TB0CLE> = "1", UC0 is cleared if when the comparator detects a match between counter value and the value set in TB0RG1. UC0 operates as a free-running counter if TB0MOD<TB0CLE> = "0".

2) When UC0 stops

UC0 stops counting and clears counter value if TB0RUN <TB0RUN> = "0".

- UC0 overflow

If UC0 overflow occurs, the INTTB0 overflow interrupt is generated.

### 10.5.3 Timer registers (TB0RG0, TB0RG1)

TB0RG0 and TB0RG1 are registers for setting values to compare with up-counter values and two registers are built into each channel. If the comparator detects a match between a value set in this timer register and that in a UC0 up-counter, it outputs the match detection signal.

- Configuration

TB0RG0 and TB0RG1 of this timer registers are paired with register buffer 0 - a double-buffered configuration. The two registers use TB0CR<TB0WBF> to control the enabling/disabling of double buffering. If <TB0WBF> = "0", double buffering is disabled and if <TB0WBF> = "1", it is enabled. If double buffering is enabled, data is transferred from register buffer 0 to the TB0RG0 and TB0RG1 timer registers when there is a match between UC0 and TB0RG1.

- Default setting

The values of TB0RG0 and TB0RG1 become undefined after a reset. A reset disables the double buffer.

- Register setting

- 1) When not using double-buffering

To write data to the timer registers, either a 2-byte data transfer instruction or a 1-byte data transfer instruction written twice in the order of low-order 8 bits followed by high-order 8 bits can be used.

- 2) When using double-buffering

TB0RG0/ TB0RG1 and the register buffers are assigned to the same address. If <TB0WBF> = "0," the same value is written to TB0RG0, TB0RG1 and each register buffer; if <TB0WBF> = "1," the value is only written to each register buffer. To write an initial value to the timer register, therefore, the register buffers must be set to "disable". Then set <TB0WBF> = "1" and write the following data to the register.

#### 10.5.4 Capture

This is a circuit that controls the timing of latching values from the UC0 up-counter into the TB0CP0 and TB0CP1 capture registers. The timing with which to latch data is specified by TB0MOD <TB0CPM[1:0]>.

Software can also be used to import values from the UC0 up-counter into the capture register; specifically, UC0 values are taken into the TB0CP0 capture register each time “0” is written to TB0MOD<TB0CP0>.

#### 10.5.5 Capture Registers (TB0CP0H/L, TB0CP1H/L)

These are 16-bit registers for latching values from the UC0 up-counter.

#### 10.5.6 Up-counter capture register (TB0UCH/L)

Other than the capturing functions shown above, the current count value of the UC0 can be captured by reading the TB0UC registers.

#### 10.5.7 Comparators (CP0, CP1)

These are 16-bit comparators for detecting a match by comparing set values of the UC0 up-counter with set values of the TB0RG0 and TB0RG1 timer registers. If a match is detected, INTTB0 is generated.

#### 10.5.8 Timer Flip-flop (TB0FF0)

The timer flip-flop (TB0FF0) is reversed by a match signal from the comparator and a latch signal to the capture registers. It can be enabled or disabled to reverse by setting the TB0FFCR<TB0C1T1, TB0C0T1, TB0E1T1, TB0E0T1>.

The value of TB0FF0 becomes undefined after a reset. The flip-flop can be reversed by writing “00” to TB0FFCR<TB0FF0C1:0>. It can be set to “1” by writing “01,” and can be cleared to “0” by writing “10.”

The value of TB0FF0 can be output to the timer output pin, TB0OUT (shared with PI0). To enable timer output, the port I related registers PICR and PIFR1 must be programmed beforehand.

#### 10.5.9 Capture interrupt (INTCAP00, INTCAP01)

Interrupts INTCAP00 and INTCAP01 can be generated at the timing of latching values from the UC0 up-counter into the TB0CP0 and TB0CP1 capture registers. The interrupt timing is specified by the CPU.

## 10.6 Description of Operations for Each Mode

### 10.6.1 16-bit Interval Timer Mode

#### -Generating interrupts at periodic cycles

To generate the INTTB0 interrupt, specify a time interval in the TB0RG1 timer register.

### 10.6.2 16-bit Event Counter Mode

It is possible to make it the event counter by using an input clock as an external clock (TB0IN0 pin input).

The up-counter counts up on the rising edge of TB0IN0 pin input. It is possible to read the count value by capturing value using software and reading the captured value.

To use it as an event counter, put the prescaler in a "RUN" state (TB0RUN<TB0PRUN> = "1").

### 10.6.3 16-bit Programmable Square Wave Output Mode (PPG)

Square waves with any frequency and any duty (programmable square waves) can be output. The output pulse can be either low-active or high-active.

Programmable square waves can be output from the TB0OUT pin by triggering the timer flip-flop (TB0FF) to reverse when the set value of the up-counter (UCO) matches the set values of the timer registers (TB0RG0 and TB0RG1). Note that the set values of TB0RG0 and TB0RG1 must satisfy the following requirement:

$$(\text{Set value of TB0RG0}) < (\text{Set value of TB0RG1})$$

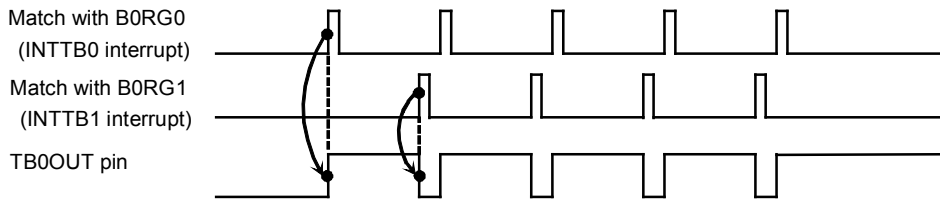

Fig. 10-2 Example of Output of Programmable Square Wave (PPG)

In this mode, by enabling the double buffering of TB0RG0, the value of register buffer 0 is shifted into TB0RG0 when the set value of the up-counter matches the set value of TB0RG1. This facilitates handling of small duties.

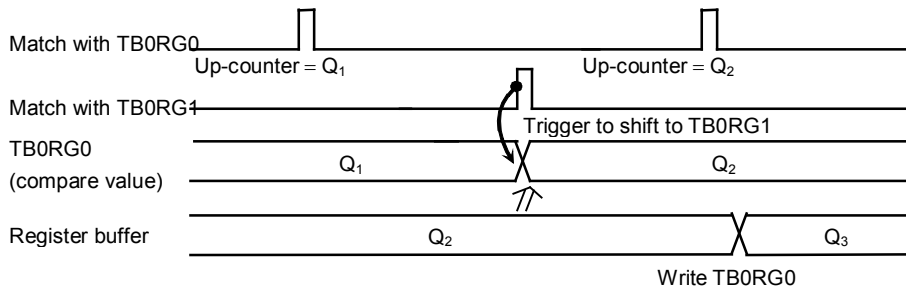

Fig. 10-3 Register Buffer Operation

The block diagram of this mode is shown below.

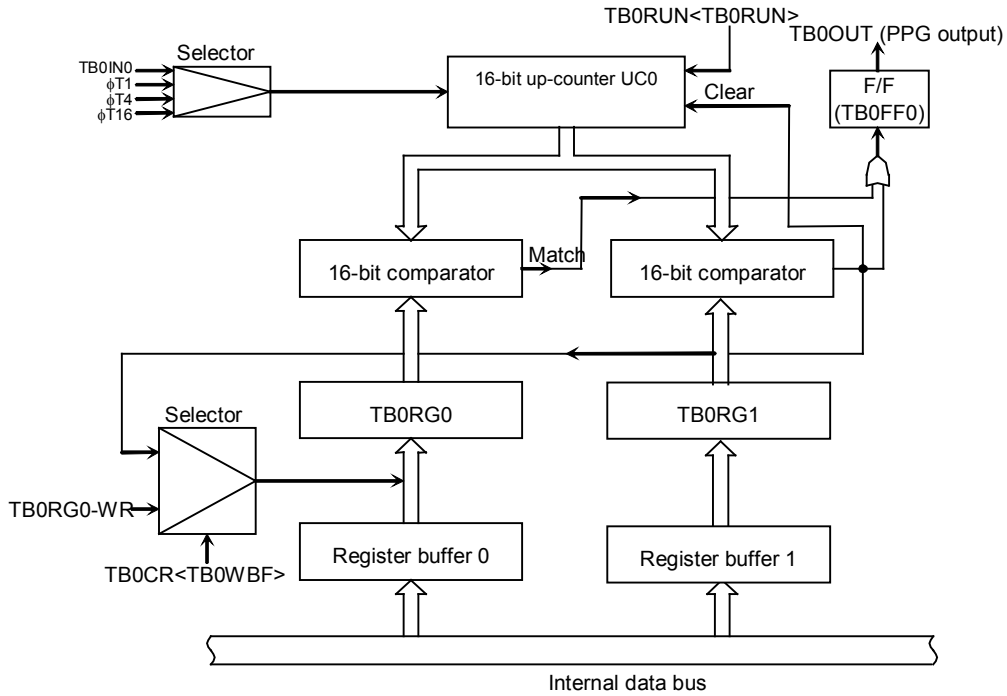

Fig. 10-4 Block Diagram of 16-bit PPG Mode

Each register in the 16-bit PPG output mode must be programmed as listed below.

	7	6	5	4	3	2	1	0	
TB0EN	← 1	X	X	X	X	X	X	X	Starts the TMRB0 module.
TB0RUN	← X	X	X	X	X	0	X	0	Stops the TMRB0 module.
TBORG0	← *	*	*	*	*	*	*	*	Specifies a duty. (16 bits *32-bits for register)
TBORG1	← *	*	*	*	*	*	*	*	Specifies a cycle. (16 bits *32-bits for register)
TB0CR	← 1	0	X	0	0	0	0	0	Enables the TBORG0 double buffering. (Changes the duty/cycle when the INTTB0 interrupt is generated)
TB0FFCR	← X	X	0	0	1	1	1	0	Specifies to trigger TB0FF0 to reverse when a match with TBORG0 or TBORG1 is detected, and sets the initial value of TB0FF0 to "0."
TB0MOD	← 0	0	1	0	0	1	*	*	Designates the prescaler output clock as the input clock, and disables the capture function. (* = 01, 10, 11)
PICR	← -	-	-	-	-	-	-	1	Assigns PI0 to TB0OUT
PIFR1	← -	-	-	-	-	-	-	1	
TB0RUN	← *	*	*	*	*	1	X	1	Starts TMRB0

X; Don't care -; no change

### 10.7 Timer synchronous mode

This mode enables the timers to start synchronously.

If the mode is used with PPG output, the output can be applied to drive a motor.

Use of the timer synchronous mode is specified in TBNCR<TBNSYNC>.

<TBNSYNC> =“0”: Timers operates individually.

<TBNSYNC> =“1”: Timers operate synchronously.

The channels are in two segments: channels TMRB0 through 3 and channels TMRB4 through 7.

If <TBNSYNC> =“1” is set, the start timing is synchronized with TMRB0 and TMRB4. The start timing of each channel, TBmRUN <TBmPRUN,TBmRUN> =“1,1”, is ignored.

- (Note 1) The channels designated for synchronous output must be started by TBmRUN<TBmPRUN,TBmRUN>=“1,1” before the start triggered by TMRB0 and TMRB4.**
- (Note 2) Set TBNCR<TBNSYNC> to “0” unless the timer synchronous mode is used. The timer synchronous mode keeps the other channels operation waiting until TMRB0, TMRB4 and TMRB8 start operation.**
- (Note 3) TMRB0 and TMRB4 are the master clocks of the timer synchronous mode. Therefore, their TBNSYNC bit must be set to “0”.**
- (Note 4) This mode cannot be applied to TMRB8 and TMRB9.**

TBNCR (0x4001_0xx8)		7	6	5	4	3	2	1	0
	bit Symbol	TBNWBF		TBNSYNC		I2TBn			
	Read/Write	R/W	R/W	R/W	R	R/W	R	R	R
	After reset	0	0	0	0	0	0	0	0
	Function	Double Buffer 0:Disabled 1:Enabled	Write “0”.	Timer operation 0:Individual	“0” is read.	IDLE 0:Stop 1:Operation	“0” is read.	“0” is read.	“0” is read.

Set the TBNSYNC bit of the timers, which are used as the slave clocks, to “1”.

TBNCR (0x4001_0xx8)		7	6	5	4	3	2	1	0
	bit Symbol	TBNWBF		TBNSYNC		I2TBn			
	Read/Write	R/W	R/W	R/W	R	R/W	R	R	R
	After reset	0	0	0	0	0	0	0	0
	Function	Double Buffer 0:Disabled 1:Enabled	Write “0”.	Timer operation 1:Synchro nous	“0” is read.	IDLE 0:Stop 1:Operation	“0” is read.	“0” is read.	“0” is read.

### 10.8 Applications using the Capture Function

The capture function can be used to develop many applications, including those described below:

- ① One-shot pulse output triggered by an external pulse
- ② Frequency measurement
- ③ Pulse width measurement
- ④ Time difference measurement

① One-shot pulse output triggered by an external pulse

One-shot pulse output triggered by an external pulse is carried out as follows:

The 16-bit up-counter is made to count up by putting it in a free-running state using the prescaler output clock. An external pulse is input through the TB5IN0 pin. A trigger is generated at the rising of the external pulse by using the capture function and the value of the up-counter is taken into the capture registers (TB5CP0).

The CPU must be programmed so that an interrupt INTCAP50 is generated at the rising of an external trigger pulse. This interrupt is used to set the timer registers (TB5RG0) to the sum of the TB5CP0 value (c) and the delay time (d), (c + d), and set the timer registers (TB5RG1) to the sum of the TB5RG0 values and the pulse width (p) of one-shot pulse, (c + d + p).

TB5RG1 change must be completed before the next match.

In addition, the timer flip-flop control registers (TB5FFCR<TB5E1T1, TB5E0T1>) must be set to “11.” This enables triggering the timer flip-flop (TB5FF0) to reverse when UC5 matches TB5RG0 and TB5RG1. This trigger is disabled by the INTTB5 interrupt after a one-shot pulse is output.

Symbols (c), (d) and (p) used in the text correspond to symbols c, d and p in “Fig. 10-5 One-shot Pulse Output (With Delay).”

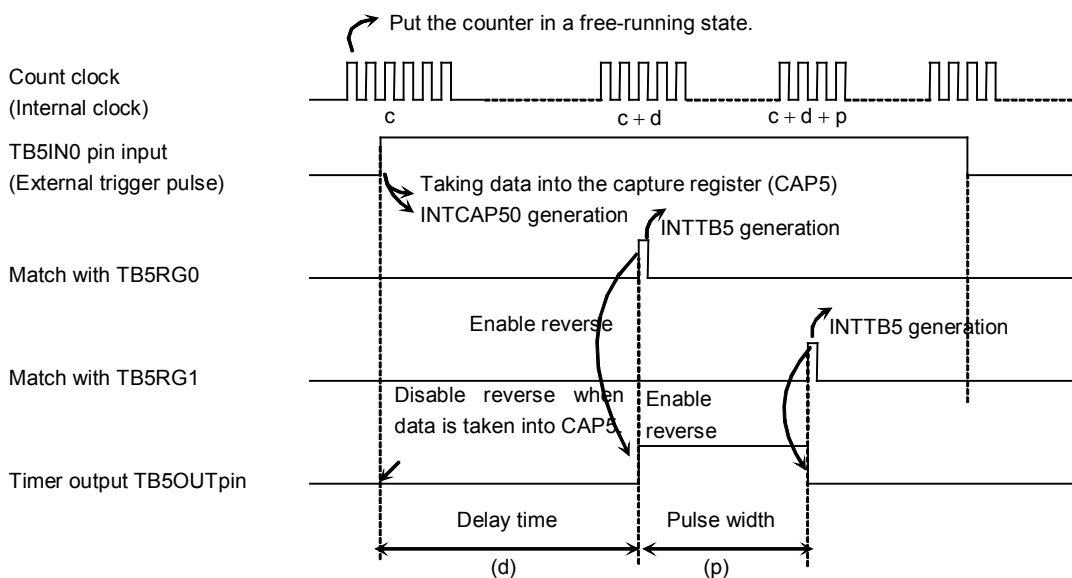

Fig. 10-5 One-shot Pulse Output (With Delay)

If a delay is not required, TB5FF0 is reversed when data is taken into TB5CP0, and TB5RG1 is set to the sum of the TB5CPO value (c) and the one-shot pulse width (p), (c + p), by generating the INT0 interrupt. TB5RG1 change must be completed before the next match. TB5FF0 is enabled to reverse when UC5 matches with TB5RG1, and is disabled by generating the INTTB5 interrupt.

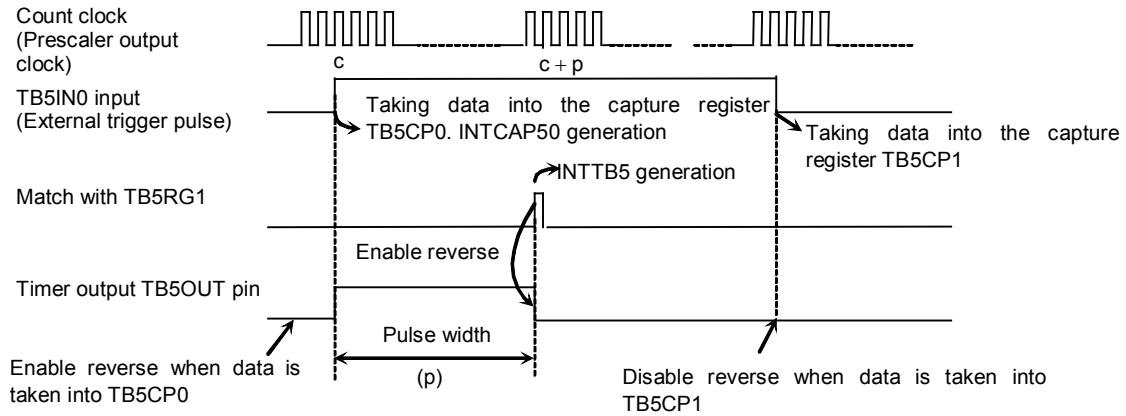

Fig. 10-6 One-shot Pulse Output Triggered by an External Pulse (Without Delay)

② Frequency measurement

The frequency of an external clock can be measured by using the capture function. To measure frequency, another 16-bit timer (TMRB0) is used in combination with the 16-bit event counter mode. As an example, we explain with TMRB3 and TMRB8. TB8OUT of the 16-bit timer TMRB8 is used to specify the measurement time. The TB3IN0 pin input is selected as the TMRB3 count clock to perform the count operation using an external input clock. TB3MOD<TB3CPM[1:0]> is set to “11.” This setting allows a count value of the 16-bit up-counter UC3 to be taken into the capture register (TB3CP0) upon rising of a timer flip-flop output (TB8OUT) of the 16-bit timer (TMRB8), and an UC3 counter value to be taken into the capture register (TB3CP1) upon falling of TB8OUT of the 16-bit timer (TMRB8). A frequency is then obtained from the difference between TB3CP0 and TB3CP1 based on the measurement, by generating the INTTB8 16-bit timer interrupt.

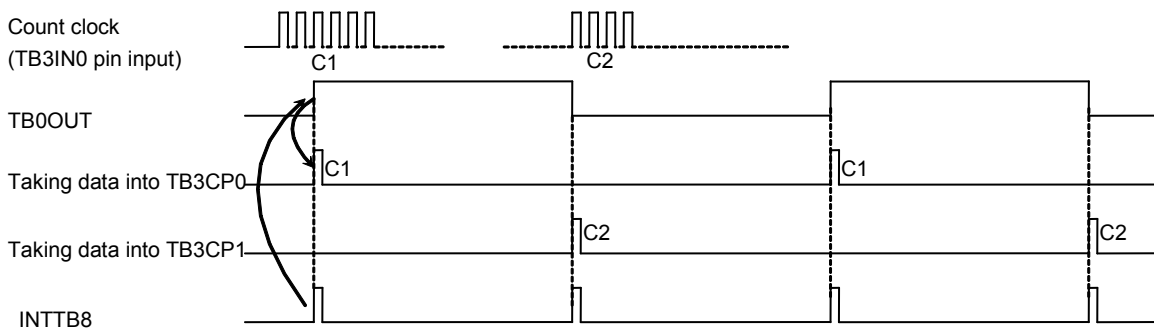

Fig. 10-7 Frequency Measurement

For example, if the set width of TB0FF level “1” of the 16-bit timer is 0.5 s and if the difference between TB3CP0 and TB3CP1 is 100, the frequency is  $100 / 0.5 \text{ s} = 200 \text{ Hz}$ .

③ Pulse width measurement

By using the capture function, the “H” level width of an external pulse can be measured. Specifically, by putting it in a free-running state using the prescaler output clock, an external pulse is input through the TB5IN0 pin and the up-counter (UC5) is made to count up. A trigger is generated at each rising and falling edge of the external pulse by using the capture function and the value of the up-counter is taken into the capture registers (TB5CP0, TB5CP1). The CPU must be programmed so that INTCAP51 is generated at the falling edge of an external pulse input through the TB5IN0 pin.

The “H” level pulse width can be calculated by multiplying the difference between TB5CP0 and TB5CP1 by the clock cycle of an internal clock.

For example, if the difference between TB5CP0 and TB5CP1 is 100 and the cycle of the prescaler output clock is 0.5  $\mu$ s, the pulse width is  $100 \times 0.5 \mu\text{s} = 50 \mu\text{s}$ .

Caution must be exercised when measuring pulse widths exceeding the UC5 maximum count time which is dependant upon the source clock used. The measurement of such pulse widths must be made using software.

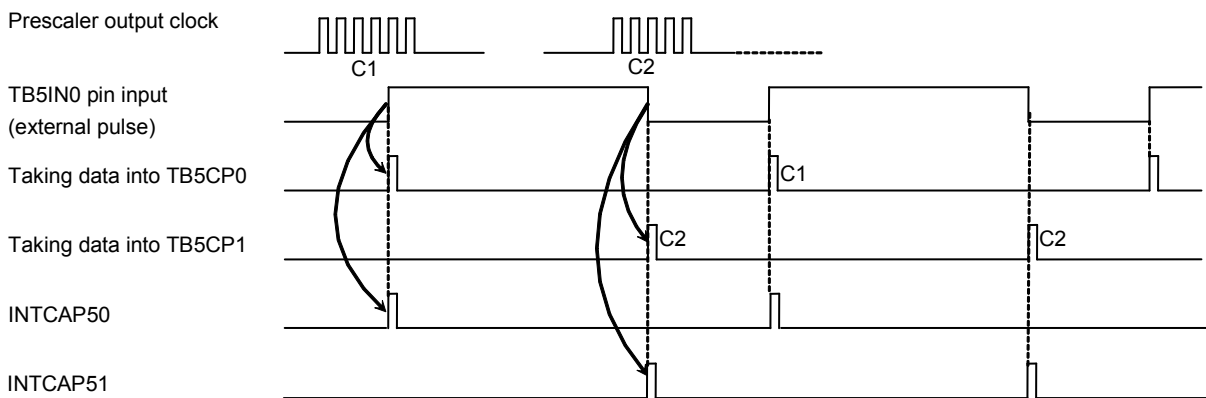

Fig. 10-8 Pulse Width Measurement

The “L” level width of an external pulse can also be measured. In such cases, the difference between C2 generated the first time and C1 generated the second time is initially obtained by performing the second stage of INTCAP50 interrupt processing as shown in “Fig. 10-8 Pulse Width Measurement” and this difference is multiplied by the cycle of the prescaler output clock to obtain the “L” level width.

## ④ Time Difference Measurement

The up-counter (UC5) is made to count up by putting it in a free-running state using the prescaler output clock. The value of UC5 is taken into the capture register (TB5CP0) at the rising edge of the TB5IN0 pin input pulse. The CPU must be programmed to generate INTCAP50 interrupt at this time.

The value of UC5 is taken into the capture register TB5CP1 at the rising edge of the TB5IN1 pin input pulse. The CPU must be programmed to generate INTCAP51 interrupt at this time.

The time difference can be calculated by multiplying the difference between TB5CP1 and TB5CP0 by the clock cycle of an internal clock.

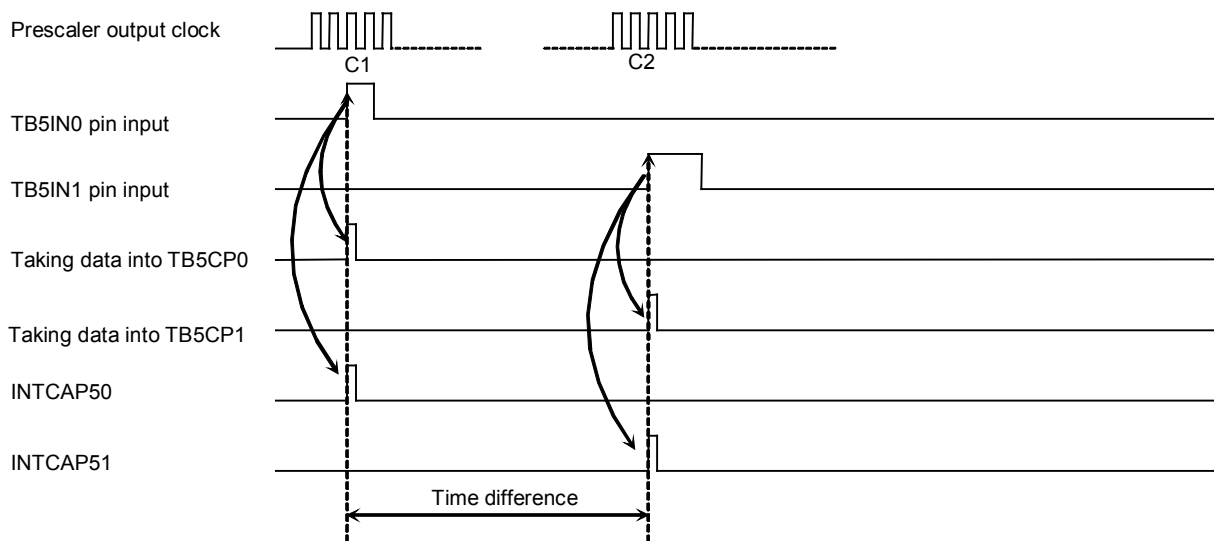

Fig. 10-9 Time Difference Measurement

## 11 Serial Channel (SIO)

### 11.1 Features

This device has three serial I/O channels: SIO0 to SIO2. Each channel operates in either the UART mode (asynchronous communication) or the I/O interface mode (synchronous communication) which is selected by the user.

I/O interface mode  
data

—— Mode 0: This is the mode to transmit and receive I/O  
and associated synchronization signals (SCLK) to extend  
I/O.

Asynchronous (UART) mode:

— Mode 1: TX/RX Data Length: 7 bits  
— Mode 2: TX/RX Data Length: 8 bits  
— Mode 3: TX/RX Data Length: 9 bits

In the above modes 1 and 2, parity bits can be added. The mode 3 has a wakeup function in which the master controller can start up slave controllers via the serial link (multi-controller system). Fig. 11-2 shows the block diagram of SIO0.

Each channel consists of a prescaler, a serial clock generation circuit, a receive buffer, its control circuit, a transmit buffer and its control circuit. Each channel functions independently.

As the SIOs 0 to 2 operate in the same way, only SIO0 is described here.

Table 11-1 Difference in the Specifications of SIO Modules

		Channel 0	Channel 1	Channel 2
Pin name		TXD0 (PE0) RXD0 (PE1) $\overline{\text{CTS}}_0$ / SCLK0 (PE2)	TXD1 (PE4) RXD1 (PE5) $\overline{\text{CTS}}_1$ / SCLK1 (PE6)	TXD1 (PF0) RXD1 (PF1) $\overline{\text{CTS}}_1$ / SCLK1 (PF2)
Interrupt		INTRX0 INTTX0	INTRX1 INTTX1	INTRX2 INTTX2
Register name (address)	Enable register	SC0EN 0x4002_0080	SC1EN 0x4002_00C0	SC2EN 0x4002_0100
	Transmit/ receive buffer register	SC0BUF 0x4002_0084	SC1BUF 0x4002_00C4	SC2BUF 0x4002_0104
	Control register	SC0CR 0x4002_0088	SC1CR 0x4002_00C8	SC2CR 0x4002_0108
	Mode control register 0	SC0MOD0 0x4002_008C	SC1MOD0 0x4002_00CC	SC2MOD0 0x4002_010C
	Baud rate generator control	SC0BRCR 0x4002_0090	SC1BRCR 0x4002_00D0	SC2BRCR 0x4002_0110
	Baud rate generator control 2	SC0BRADD 0x4002_0094	SC1BRADD 0x4002_00D4	SC2BRADD 0x4002_0114
	Mode control register 1	SC0MOD1 0x4002_0098	SC1MOD1 0x4002_00D8	SC2MOD1 0x4002_0118
	Mode control register 2	SC0MOD2 0x4002_009C	SC1MOD2 0x4002_00DC	SC2MOD2 0x4002_011C
	Receive FIFO configuration register	SC0RFC 0x4002_00A0	SC1RFC 0x4002_00E0	SC2RFC 0x4002_0120
	Transmit FIFO configuration register	SC0TFC 0x4002_00A4	SC1TFC 0x4002_00E4	SC2TFC 0x4002_0124
	Receive FIFO status register	SC0RST 0x4002_00A8	SC1RST 0x4002_00E8	SC2RST 0x4002_0128
	Transmit FIFO status register	SC0TST 0x4002_00AC	SC1TST 0x4002_00EC	SC2TST 0x4002_012C
	FIFO configuration register	SC0FCNF 0x4002_00B0	SC1FCNF 0x4002_00F0	SC2FCNF 0x4002_0130

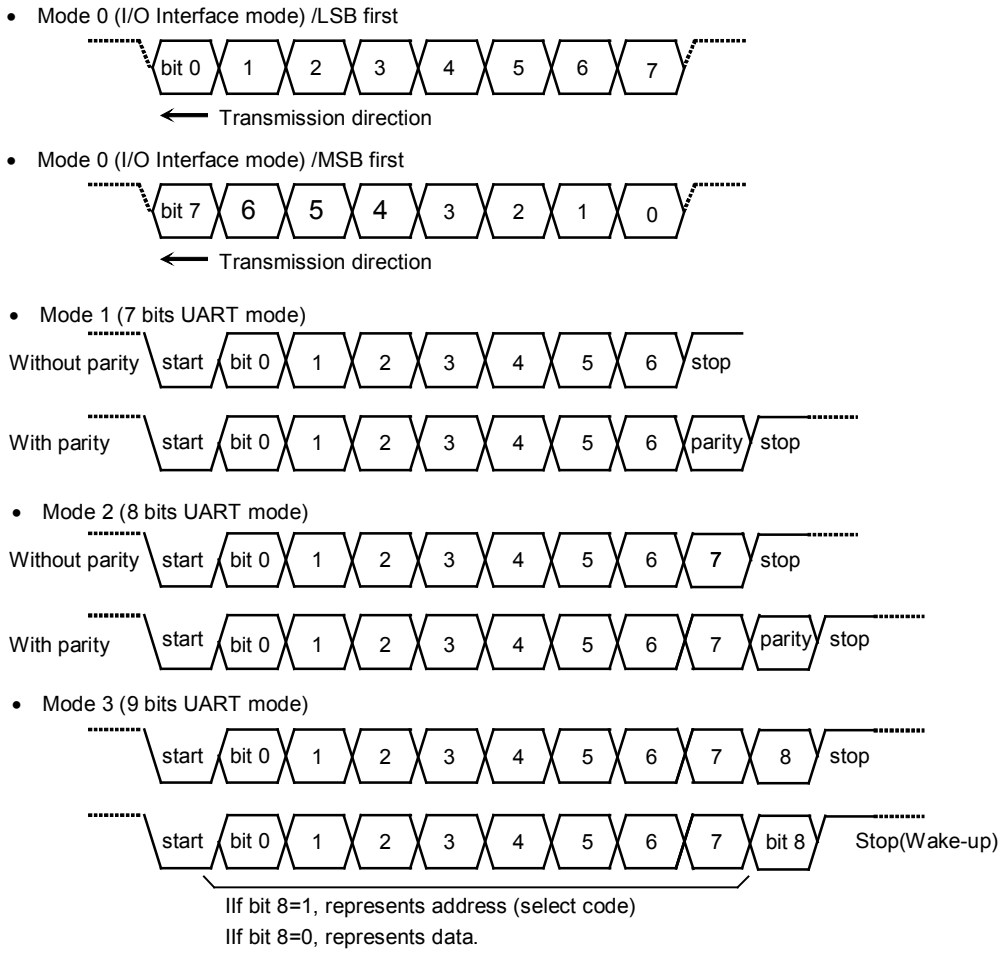

Fig. 11-1 Data Format

11.2 Block Diagram (Channel 0)

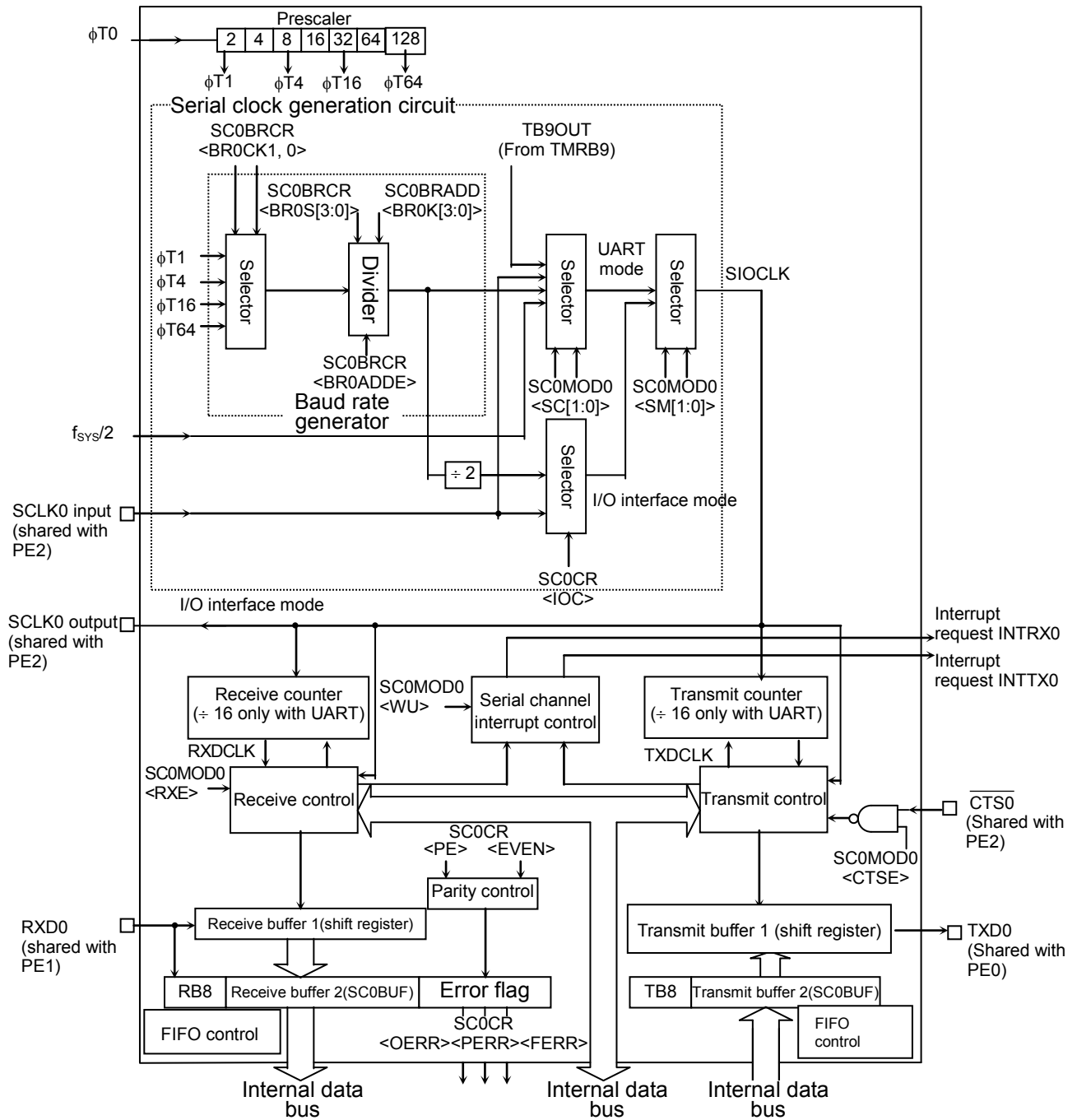

Fig. 11-2 SIO0 Block Diagram

## 11.3 Operation of Each Circuit (Channel 0)

### 11.3.1 Prescaler

The device includes a 7-bit prescaler to generate necessary clocks to drive SIO0. The input clock  $\phi T0$  to the prescaler is selected by CGSYSCR of CG <PRCK[2:0]> to provide the frequency of either  $f_{periph}/1$ ,  $f_{periph}/2$ ,  $f_{periph}/4$ ,  $f_{periph}/8$ ,  $f_{periph}/16$  or  $f_{periph}/32$ .

The clock frequency  $f_{periph}$  is either the clock “fgear,” to be selected by CGSYSCR<FPSEL> of CG, or the clock “fc” before it is divided by the clock gear.

The prescaler becomes active only when the baud rate generator is selected for generating the serial transfer clock. Table 11-2 and Table 11-3 list the prescaler output clock resolution.

Table 11-2 Clock Resolution to the Baud Rate Generator @ = 40MHz

Clear peripheral clock <FPSEL>	Clock gear value <GEAR[2:0]>	Prescaler clock selection <PRCK[2:0]>	Prescaler output clock resolution			
			$\phi T1$	$\phi T4$	$\phi T16$	$\phi T64$
0 (fgear)	000 (fc)	000(fperiph/1)	$fc/2^1(0.05\mu s)$	$fc/2^3(0.2\mu s)$	$fc/2^5(0.8\mu s)$	$fc/2^7(3.2\mu s)$
		001(fperiph/2)	$fc/2^2(0.1\mu s)$	$fc/2^4(0.4\mu s)$	$fc/2^6(1.6\mu s)$	$fc/2^8(6.4\mu s)$
		010(fperiph/4)	$fc/2^3(0.2\mu s)$	$fc/2^5(0.8\mu s)$	$fc/2^7(3.2\mu s)$	$fc/2^9(12.8\mu s)$
		011(fperiph/8)	$fc/2^4(0.4\mu s)$	$fc/2^6(1.6\mu s)$	$fc/2^8(6.4\mu s)$	$fc/2^{10}(25.6\mu s)$
		100(fperiph/16)	$fc/2^5(0.8\mu s)$	$fc/2^7(3.2\mu s)$	$fc/2^9(12.8\mu s)$	$fc/2^{11}(51.2\mu s)$
		101(fperiph/32)	$fc/2^6(1.6\mu s)$	$fc/2^8(6.4\mu s)$	$fc/2^{10}(25.6\mu s)$	$fc/2^{12}(102.4\mu s)$
	100(fc/2)	000(fperiph/1)	$fc/2^2(0.1\mu s)$	$fc/2^4(0.4\mu s)$	$fc/2^6(1.6\mu s)$	$fc/2^8(6.4\mu s)$
		001(fperiph/2)	$fc/2^3(0.2\mu s)$	$fc/2^5(0.8\mu s)$	$fc/2^7(3.2\mu s)$	$fc/2^9(12.8\mu s)$
		010(fperiph/4)	$fc/2^4(0.4\mu s)$	$fc/2^6(1.6\mu s)$	$fc/2^8(6.4\mu s)$	$fc/2^{10}(25.6\mu s)$
		011(fperiph/8)	$fc/2^5(0.8\mu s)$	$fc/2^7(3.2\mu s)$	$fc/2^9(12.8\mu s)$	$fc/2^{11}(51.2\mu s)$
		100(fperiph/16)	$fc/2^6(1.6\mu s)$	$fc/2^8(6.4\mu s)$	$fc/2^{10}(25.6\mu s)$	$fc/2^{12}(102.4\mu s)$
		101(fperiph/32)	$fc/2^7(3.2\mu s)$	$fc/2^9(12.8\mu s)$	$fc/2^{11}(51.2\mu s)$	$fc/2^{13}(204.8\mu s)$
	101(fc/4)	000(fperiph/1)	$fc/2^3(0.2\mu s)$	$fc/2^5(0.8\mu s)$	$fc/2^7(3.2\mu s)$	$fc/2^9(12.8\mu s)$
		001(fperiph/2)	$fc/2^4(0.4\mu s)$	$fc/2^6(1.6\mu s)$	$fc/2^8(6.4\mu s)$	$fc/2^{10}(25.6\mu s)$
		010(fperiph/4)	$fc/2^5(0.8\mu s)$	$fc/2^7(3.2\mu s)$	$fc/2^9(12.8\mu s)$	$fc/2^{11}(51.2\mu s)$
		011(fperiph/8)	$fc/2^6(1.6\mu s)$	$fc/2^8(6.4\mu s)$	$fc/2^{10}(25.6\mu s)$	$fc/2^{12}(102.4\mu s)$
		100(fperiph/16)	$fc/2^7(3.2\mu s)$	$fc/2^9(12.8\mu s)$	$fc/2^{11}(51.2\mu s)$	$fc/2^{13}(204.8\mu s)$
		101(fperiph/32)	$fc/2^8(6.4\mu s)$	$fc/2^{10}(25.6\mu s)$	$fc/2^{12}(102.4\mu s)$	$fc/2^{14}(409.6\mu s)$
	110(fc/8)	000(fperiph/1)	$fc/2^4(0.4\mu s)$	$fc/2^6(1.6\mu s)$	$fc/2^8(6.4\mu s)$	$fc/2^{10}(25.6\mu s)$
		001(fperiph/2)	$fc/2^5(0.8\mu s)$	$fc/2^7(3.2\mu s)$	$fc/2^9(12.8\mu s)$	$fc/2^{11}(51.2\mu s)$
		010(fperiph/4)	$fc/2^6(1.6\mu s)$	$fc/2^8(6.4\mu s)$	$fc/2^{10}(25.6\mu s)$	$fc/2^{12}(102.4\mu s)$
		011(fperiph/8)	$fc/2^7(3.2\mu s)$	$fc/2^9(12.8\mu s)$	$fc/2^{11}(51.2\mu s)$	$fc/2^{13}(204.8\mu s)$
		100(fperiph/16)	$fc/2^8(6.4\mu s)$	$fc/2^{10}(25.6\mu s)$	$fc/2^{12}(102.4\mu s)$	$fc/2^{14}(409.6\mu s)$
		101(fperiph/32)	$fc/2^9(12.8\mu s)$	$fc/2^{11}(51.2\mu s)$	$fc/2^{13}(204.8\mu s)$	$fc/2^{15}(819.2\mu s)$
1 (fc)	000 (fc)	000(fperiph/1)	$fc/2^1(0.05\mu s)$	$fc/2^3(0.2\mu s)$	$fc/2^5(0.8\mu s)$	$fc/2^7(3.2\mu s)$
		001(fperiph/2)	$fc/2^2(0.1\mu s)$	$fc/2^4(0.4\mu s)$	$fc/2^6(1.6\mu s)$	$fc/2^8(6.4\mu s)$
		010(fperiph/4)	$fc/2^3(0.2\mu s)$	$fc/2^5(0.8\mu s)$	$fc/2^7(3.2\mu s)$	$fc/2^9(12.8\mu s)$
		011(fperiph/8)	$fc/2^4(0.4\mu s)$	$fc/2^6(1.6\mu s)$	$fc/2^8(6.4\mu s)$	$fc/2^{10}(25.6\mu s)$
		100(fperiph/16)	$fc/2^5(0.8\mu s)$	$fc/2^7(3.2\mu s)$	$fc/2^9(12.8\mu s)$	$fc/2^{11}(51.2\mu s)$
		101(fperiph/32)	$fc/2^6(1.6\mu s)$	$fc/2^8(6.4\mu s)$	$fc/2^{10}(25.6\mu s)$	$fc/2^{12}(102.4\mu s)$
	100(fc/2)	000(fperiph/1)	-	$fc/2^3(0.2\mu s)$	$fc/2^5(0.8\mu s)$	$fc/2^7(3.2\mu s)$
		001(fperiph/2)	$fc/2^2(0.1\mu s)$	$fc/2^4(0.4\mu s)$	$fc/2^6(1.6\mu s)$	$fc/2^8(6.4\mu s)$
		010(fperiph/4)	$fc/2^3(0.2\mu s)$	$fc/2^5(0.8\mu s)$	$fc/2^7(3.2\mu s)$	$fc/2^9(12.8\mu s)$
		011(fperiph/8)	$fc/2^4(0.4\mu s)$	$fc/2^6(1.6\mu s)$	$fc/2^8(6.4\mu s)$	$fc/2^{10}(25.6\mu s)$
		100(fperiph/16)	$fc/2^5(0.8\mu s)$	$fc/2^7(3.2\mu s)$	$fc/2^9(12.8\mu s)$	$fc/2^{11}(51.2\mu s)$
		101(fperiph/32)	$fc/2^6(1.6\mu s)$	$fc/2^8(6.4\mu s)$	$fc/2^{10}(25.6\mu s)$	$fc/2^{12}(102.4\mu s)$
	101(fc/4)	000(fperiph/1)	-	$fc/2^3(0.2\mu s)$	$fc/2^5(0.8\mu s)$	$fc/2^7(3.2\mu s)$
		001(fperiph/2)	-	$fc/2^4(0.4\mu s)$	$fc/2^6(1.6\mu s)$	$fc/2^8(6.4\mu s)$
		010(fperiph/4)	$fc/2^3(0.2\mu s)$	$fc/2^5(0.8\mu s)$	$fc/2^7(3.2\mu s)$	$fc/2^9(12.8\mu s)$
		011(fperiph/8)	$fc/2^4(0.4\mu s)$	$fc/2^6(1.6\mu s)$	$fc/2^8(6.4\mu s)$	$fc/2^{10}(25.6\mu s)$
		100(fperiph/16)	$fc/2^5(0.8\mu s)$	$fc/2^7(3.2\mu s)$	$fc/2^9(12.8\mu s)$	$fc/2^{11}(51.2\mu s)$
		101(fperiph/32)	$fc/2^6(1.6\mu s)$	$fc/2^8(6.4\mu s)$	$fc/2^{10}(25.6\mu s)$	$fc/2^{12}(102.4\mu s)$
	110(fc/8)	000(fperiph/1)	-	-	$fc/2^5(0.8\mu s)$	$fc/2^7(3.2\mu s)$
		001(fperiph/2)	-	$fc/2^4(0.4\mu s)$	$fc/2^6(1.6\mu s)$	$fc/2^8(6.4\mu s)$
		010(fperiph/4)	-	$fc/2^5(0.8\mu s)$	$fc/2^7(3.2\mu s)$	$fc/2^9(12.8\mu s)$
		011(fperiph/8)	$fc/2^4(0.4\mu s)$	$fc/2^6(1.6\mu s)$	$fc/2^8(6.4\mu s)$	$fc/2^{10}(25.6\mu s)$
		100(fperiph/16)	$fc/2^5(0.8\mu s)$	$fc/2^7(3.2\mu s)$	$fc/2^9(12.8\mu s)$	$fc/2^{11}(51.2\mu s)$
		101(fperiph/32)	$fc/2^6(1.6\mu s)$	$fc/2^8(6.4\mu s)$	$fc/2^{10}(25.6\mu s)$	$fc/2^{12}(102.4\mu s)$

- (Note 1)** The prescaler output clock  $\phi T_n$  must be selected so that the relationship “ $\phi T_n < f_{sys}$ ” is satisfied (so that  $\phi T_n$  is slower than  $f_{sys}$ ).
- (Note 2)** Do not change the clock gear while SIO is operating.
- (Note 3)** The horizontal lines in the above table indicate that the setting is prohibited.

The serial interface baud rate generator uses four different clocks, i.e.,  $\phi T_1$ ,  $\phi T_4$ ,  $\phi T_{16}$  and  $\phi T_{64}$ , supplied from the prescaler output clock.

Table 11-3 Clock Resolution to the Baud Rate Generator

@ = 32MHz

Clear peripheral clock <FPSEL>	Clock gear value <GEAR[2:0]>	Prescaler clock selection <PRCK[2:0]>	Prescaler output clock resolution			
			$\phi T1$	$\phi T4$	$\phi T16$	$\phi T64$
0 (fgear)	000 (fc)	000(fperiph/1)	$fc/2^1(0.0625\mu s)$	$fc/2^3(0.25\mu s)$	$fc/2^5(1.0\mu s)$	$fc/2^7(4.0\mu s)$
		001(fperiph/2)	$fc/2^2(0.125\mu s)$	$fc/2^4(0.5\mu s)$	$fc/2^6(2.0\mu s)$	$fc/2^8(8.0\mu s)$
		010(fperiph/4)	$fc/2^3(0.25\mu s)$	$fc/2^5(1.0\mu s)$	$fc/2^7(4.0\mu s)$	$fc/2^9(16.0\mu s)$
		011(fperiph/8)	$fc/2^4(0.5\mu s)$	$fc/2^6(2.0\mu s)$	$fc/2^8(8.0\mu s)$	$fc/2^{10}(32.0\mu s)$
		100(fperiph/16)	$fc/2^5(1.0\mu s)$	$fc/2^7(4.0\mu s)$	$fc/2^9(16.0\mu s)$	$fc/2^{11}(64.0\mu s)$
		101(fperiph/32)	$fc/2^6(2.0\mu s)$	$fc/2^8(8.0\mu s)$	$fc/2^{10}(32.0\mu s)$	$fc/2^{12}(128.0\mu s)$
	100(fc/2)	000(fperiph/1)	$fc/2^1(0.0625\mu s)$	$fc/2^4(0.5\mu s)$	$fc/2^6(2.0\mu s)$	$fc/2^8(8.0\mu s)$
		001(fperiph/2)	$fc/2^3(0.25\mu s)$	$fc/2^5(1.0\mu s)$	$fc/2^7(4.0\mu s)$	$fc/2^9(16.0\mu s)$
		010(fperiph/4)	$fc/2^4(0.5\mu s)$	$fc/2^6(2.0\mu s)$	$fc/2^8(8.0\mu s)$	$fc/2^{10}(32.0\mu s)$
		011(fperiph/8)	$fc/2^5(1.0\mu s)$	$fc/2^7(4.0\mu s)$	$fc/2^9(16.0\mu s)$	$fc/2^{11}(64.0\mu s)$
		100(fperiph/16)	$fc/2^6(2.0\mu s)$	$fc/2^8(8.0\mu s)$	$fc/2^{10}(32.0\mu s)$	$fc/2^{12}(128.0\mu s)$
		101(fperiph/32)	$fc/2^7(4.0\mu s)$	$fc/2^9(16.0\mu s)$	$fc/2^{11}(64.0\mu s)$	$fc/2^{13}(256.0\mu s)$
	101(fc/4)	000(fperiph/1)	$fc/2^1(0.0625\mu s)$	$fc/2^5(1.0\mu s)$	$fc/2^7(4.0\mu s)$	$fc/2^9(16.0\mu s)$
		001(fperiph/2)	$fc/2^4(0.5\mu s)$	$fc/2^6(2.0\mu s)$	$fc/2^8(8.0\mu s)$	$fc/2^{10}(32.0\mu s)$
		010(fperiph/4)	$fc/2^5(1.0\mu s)$	$fc/2^7(4.0\mu s)$	$fc/2^9(16.0\mu s)$	$fc/2^{11}(64.0\mu s)$
		011(fperiph/8)	$fc/2^6(2.0\mu s)$	$fc/2^8(8.0\mu s)$	$fc/2^{10}(32.0\mu s)$	$fc/2^{12}(128.0\mu s)$
		100(fperiph/16)	$fc/2^7(4.0\mu s)$	$fc/2^9(16.0\mu s)$	$fc/2^{11}(64.0\mu s)$	$fc/2^{13}(256.0\mu s)$
		101(fperiph/32)	$fc/2^8(8.0\mu s)$	$fc/2^{10}(32.0\mu s)$	$fc/2^{12}(128.0\mu s)$	$fc/2^{14}(512.0\mu s)$
	110(fc/8)	000(fperiph/1)	$fc/2^1(0.0625\mu s)$	$fc/2^6(2.0\mu s)$	$fc/2^8(8.0\mu s)$	$fc/2^{10}(32.0\mu s)$
		001(fperiph/2)	$fc/2^5(1.0\mu s)$	$fc/2^7(4.0\mu s)$	$fc/2^9(16.0\mu s)$	$fc/2^{11}(64.0\mu s)$
		010(fperiph/4)	$fc/2^6(2.0\mu s)$	$fc/2^8(8.0\mu s)$	$fc/2^{10}(32.0\mu s)$	$fc/2^{12}(128.0\mu s)$
		011(fperiph/8)	$fc/2^7(4.0\mu s)$	$fc/2^9(16.0\mu s)$	$fc/2^{11}(64.0\mu s)$	$fc/2^{13}(256.0\mu s)$
		100(fperiph/16)	$fc/2^8(8.0\mu s)$	$fc/2^{10}(32.0\mu s)$	$fc/2^{12}(128.0\mu s)$	$fc/2^{14}(512.0\mu s)$
		101(fperiph/32)	$fc/2^9(16.0\mu s)$	$fc/2^{11}(64.0\mu s)$	$fc/2^{13}(256.0\mu s)$	$fc/2^{15}(1024\mu s)$
1 (fc)	000 (fc)	000(fperiph/1)	$fc/2^1(0.0625\mu s)$	$fc/2^3(0.25\mu s)$	$fc/2^5(1.0\mu s)$	$fc/2^7(4.0\mu s)$
		001(fperiph/2)	$fc/2^2(0.125\mu s)$	$fc/2^4(0.5\mu s)$	$fc/2^6(2.0\mu s)$	$fc/2^8(8.0\mu s)$
		010(fperiph/4)	$fc/2^3(0.25\mu s)$	$fc/2^5(1.0\mu s)$	$fc/2^7(4.0\mu s)$	$fc/2^9(16.0\mu s)$
		011(fperiph/8)	$fc/2^4(0.5\mu s)$	$fc/2^6(2.0\mu s)$	$fc/2^8(8.0\mu s)$	$fc/2^{10}(32.0\mu s)$
		100(fperiph/16)	$fc/2^5(1.0\mu s)$	$fc/2^7(4.0\mu s)$	$fc/2^9(16.0\mu s)$	$fc/2^{11}(64.0\mu s)$
		101(fperiph/32)	$fc/2^6(2.0\mu s)$	$fc/2^8(8.0\mu s)$	$fc/2^{10}(32.0\mu s)$	$fc/2^{12}(128.0\mu s)$
	100(fc/2)	000(fperiph/1)	-	$fc/2^3(0.25\mu s)$	$fc/2^5(1.0\mu s)$	$fc/2^7(4.0\mu s)$
		001(fperiph/2)	$fc/2^2(0.125\mu s)$	$fc/2^4(0.5\mu s)$	$fc/2^6(2.0\mu s)$	$fc/2^8(8.0\mu s)$
		010(fperiph/4)	$fc/2^3(0.25\mu s)$	$fc/2^5(1.0\mu s)$	$fc/2^7(4.0\mu s)$	$fc/2^9(16.0\mu s)$
		011(fperiph/8)	$fc/2^4(0.5\mu s)$	$fc/2^6(2.0\mu s)$	$fc/2^8(8.0\mu s)$	$fc/2^{10}(32.0\mu s)$
		100(fperiph/16)	$fc/2^5(1.0\mu s)$	$fc/2^7(4.0\mu s)$	$fc/2^9(16.0\mu s)$	$fc/2^{11}(64.0\mu s)$
		101(fperiph/32)	$fc/2^6(2.0\mu s)$	$fc/2^8(8.0\mu s)$	$fc/2^{10}(32.0\mu s)$	$fc/2^{12}(128.0\mu s)$
	101(fc/4)	000(fperiph/1)	-	$fc/2^3(0.25\mu s)$	$fc/2^5(1.0\mu s)$	$fc/2^7(4.0\mu s)$
		001(fperiph/2)	-	$fc/2^4(0.5\mu s)$	$fc/2^6(2.0\mu s)$	$fc/2^8(8.0\mu s)$
		010(fperiph/4)	$fc/2^3(0.25\mu s)$	$fc/2^5(1.0\mu s)$	$fc/2^7(4.0\mu s)$	$fc/2^9(16.0\mu s)$
		011(fperiph/8)	$fc/2^4(0.5\mu s)$	$fc/2^6(2.0\mu s)$	$fc/2^8(8.0\mu s)$	$fc/2^{10}(32.0\mu s)$
		100(fperiph/16)	$fc/2^5(1.0\mu s)$	$fc/2^7(4.0\mu s)$	$fc/2^9(16.0\mu s)$	$fc/2^{11}(64.0\mu s)$
		101(fperiph/32)	$fc/2^6(2.0\mu s)$	$fc/2^8(8.0\mu s)$	$fc/2^{10}(32.0\mu s)$	$fc/2^{12}(128.0\mu s)$
	110(fc/8)	000(fperiph/1)	-	-	$fc/2^5(1.0\mu s)$	$fc/2^7(4.0\mu s)$
		001(fperiph/2)	-	$fc/2^4(0.5\mu s)$	$fc/2^6(2.0\mu s)$	$fc/2^8(8.0\mu s)$
		010(fperiph/4)	-	$fc/2^5(1.0\mu s)$	$fc/2^7(4.0\mu s)$	$fc/2^9(16.0\mu s)$
		011(fperiph/8)	$fc/2^4(0.5\mu s)$	$fc/2^6(2.0\mu s)$	$fc/2^8(8.0\mu s)$	$fc/2^{10}(32.0\mu s)$
		100(fperiph/16)	$fc/2^5(1.0\mu s)$	$fc/2^7(4.0\mu s)$	$fc/2^9(16.0\mu s)$	$fc/2^{11}(64.0\mu s)$
		101(fperiph/32)	$fc/2^6(2.0\mu s)$	$fc/2^8(8.0\mu s)$	$fc/2^{10}(32.0\mu s)$	$fc/2^{12}(128.0\mu s)$

- (Note 1)** The prescaler output clock  $\phi T_n$  must be selected so that the relationship “ $\phi T_n < f_{sys}$ ” is satisfied (so that  $\phi T_n$  is slower than  $f_{sys}$ ).
- (Note 2)** Do not change the clock gear while SIO is operating.
- (Note 3)** The horizontal lines in the above table indicate that the setting is prohibited.

The serial interface baud rate generator uses four different clocks, i.e.,  $\phi T_1$ ,  $\phi T_4$ ,  $\phi T_{16}$  and  $\phi T_{64}$ , supplied from the prescaler output clock.

### 11.3.2 Baud Rate Generator

The baud rate generator generates transmit and receive clocks to determine the serial channel transfer rate.

The baud rate generator uses either the  $\phi T1$ ,  $\phi T4$ ,  $\phi T16$  or  $\phi T64$  clock supplied from the 7-bit prescaler. This input clock selection is made by setting the baud rate generator control register, SC0BRCCR <BR0CK[1:0]>.

The baud rate generator contains built-in dividers for divide by 1,  $N + m/16$  ( $N=2\sim 15$ ,  $m=0\sim 15$ ), and 16. The division is performed according to the settings of the baud rate generator control registers SC0BRCCR <BR0ADDE> <BR0S[3:0]> and SC0BRADD <BR0K[3:0]> to determine the resulting transfer rate.

- UART mode

- 1) If SC0BRCCR <BR0ADDE> = 0,

The setting of SC0BRADD <BR0K[3:0]> is ignored and the counter is divided by N where N is the value set to SC0BRCCR <BR0S[3:0]>. ( $N = 1$  to 16).

- 2) If SC0BRCCR <BR0ADDE> = 1,

The  $N + (16 - K)/16$  division function is enabled and the division is made by using the values N (set in SC0BRCCR <BR0S[3:0]>) and K (set in SC0BRADD <BR0K[3:0]>). ( $N = 2$  to 15,  $K = 1$  to 15)

**(Note) For the N values of 1 and 16, the above  $N+(16-K)/16$  division function is inhibited. So, be sure to set SC0BRCCR<BR0ADDE> to "0."**

- I/O interface mode

The  $N + (16 - K)/16$  division function cannot be used in the I/O interface mode. Be sure to divide by N, by setting SC0BRCCR <BR0ADDE> to "0".

- Baud rate calculation to use the baud rate generator:

- 1) UART mode

$$\text{Baud rate} = \frac{\text{Baud rated generator input clock}}{\text{Frequency divided by the divide ratio}} / 16$$

The highest baud rate out of the baud rate generator is 1.25 Mbps when  $\phi T1$  is 20 MHz.

The  $f_{\text{sys}}$  frequency, which is independent of the baud rate generator, can be used as the serial clock. In this case, the highest baud rate will be 2.5 Mbps when  $f_{\text{sys}}$  is 40 MHz.

- 2) I/O interface mode

$$\text{Baud rate} = \frac{\text{Baud rated generator input clock}}{\text{Frequency divided by the divide ratio}} / 2$$

The highest baud rate will be generated when  $\phi T1$  is 20 MHz. The divide ratio can be set to 1 if double buffer is used and the resulting output baud rate will be 10 Mbps. (If double buffering is not used, the highest baud rate will be 5.0 Mbps applying the divide ratio of "2").



- Baud rate calculation for an external clock input:

- 1) UART mode

Baud Rate = external clock input / 16

In this, the period of the external clock input must be equal to or greater than  $2/f_{sys}$ .

If  $f_{sys} = 40$  MHz, the highest baud rate will be  $40 \div 2 \div 16 = 1.25$  (Mbps).

- 2) I/O interface mode

Baud Rate = external clock input

When double buffering is used, it is necessary to satisfy the following relationship:

External clock input period  $> 6/f_{sys}$

Therefore, when  $f_{sys} = 40$  MHz, the baud rate must be set to a rate lower than  $40 \div 6 = 6.66$  (Mbps).

When double buffering is not used, it is necessary to satisfy the following relationship:

External clock input period  $> 8/f_{sys}$

Therefore, when  $f_{sys} = 40$  MHz, the baud rate must be set to a rate lower than  $40 \div 8 = 5.0$  (Mbps).

The baud rate examples for the UART mode are shown in Table 11-4 and Table 11-5.

Table 11-4 Selection of UART Baud Rate  
(Using the baud rate generator with SC0BRCR <BR0ADDE> = 0) Unit: (kbps)

fc [MHz]	Input clock				
	Divide ratio N (Set to SC0BRCR <BR0S[3:0]>)	$\phi T1$ (fc/4)	$\phi T4$ (fc/16)	$\phi T16$ (fc/64)	$\phi T64$ (fc/256)
9.830400	2	76.800	19.200	4.800	1.200
↑	4	38.400	9.600	2.400	0.600
↑	8	19.200	4.800	1.200	0.300
↑	0	9.600	2.400	0.600	0.150

**(Note)** This table shows the case where the system clock is set to fc, the clock gear is set to fc/1, and the prescaler clock is set to  $f_{periph}/2$ .

Table 11-5 Selection of UART Baud Rate  
(The TMRB9 timer output (internal TB9OUT) is used with the timer input clock set to  $\phi T0$ .) Unit: (Kbbs)

TB0RG	fc		
	32 MHz	9.8304 MHz	8 MHz
1H	250	76.8	62.5
2H	125	38.4	31.25
3H		25.6	
4H	62.5	19.2	15.625
5H	50	15.36	12.5
6H		12.8	
8H	31.25	9.6	
AH	25	7.68	6.25
10H	15.625	4.8	
14H	12.5	3.84	3.125

Baud rate calculation to use the TMRB9 timer:

$$\text{Transfer rate} = \frac{\text{Clock frequency selected by CGSYSCR<PRCK[1:0]>}}{(\text{TB0RG} \times 2) \times 2^{16}}$$

↑  
(When input clock to the timer TMRB9 is  $\phi T0$ )

**(Note 1)** In the I/O interface mode, the TMRB9 timer output signal cannot be used internally as the transfer clock.

**(Note 2)** This table shows the case where the system clock is set to fc, the clock gear is set to fc, and the prescaler clock is set to  $f_{periph}/4$ .

### 11.3.3 Serial Clock Generation Circuit

This circuit generates basic transmit and receive clocks.

- I/O interface mode

In the SCLK output mode with the SC0CR <IOC> serial control register set to “0,” the output of the previously mentioned baud rate generator is divided by 2 to generate the basic clock.

In the SCLK input mode with SC0CR <IOC> set to “1,” rising and falling edges are detected according to the SC0CR <SCLKS> setting to generate the basic clock.

- Asynchronous (UART) mode :

According to the settings of the serial control mode register SC0MOD0 <SC[1:0]>, either the clock from the baud rate register, the system clock ( $f_{SYS}$ ), the internal output signal of the TMRB9 timer, or the external clock (SCLKO pin) is selected to generate the basic clock, SIOCLK.

### 11.3.4 Receive Counter

The receive counter is a 4-bit binary counter used in the asynchronous (UART) mode and is up-counted by SIOCLK. Sixteen SIOCLK clock pulses are used in receiving a single data bit while the data symbol is sampled at the seventh, eighth, and ninth pulses. From these three samples, majority logic is applied to decide the received data.

### 11.3.5 Receive Control Unit

- I/O interface mode:

In the SCLK output mode with SC0CR <IOC> set to “0,” the RXD0 pin is sampled on the rising edge of the shift clock output to the SCLK0 pin.

In the SCLK input mode with SC0CR <IOC> set to “1,” the serial receive data RXD0 pin is sampled on the rising or falling edge of SCLK input depending on the SC0CR <SCLKS> setting.

- Asynchronous (UART) mode:

The receive control unit has a start bit detection circuit, which is used to initiate receive operation when a normal start bit is detected.

### 11.3.6 Receive Buffer

The receive buffer is of a dual structure to prevent overrun errors. The first receive buffer (a shift register) stores the received data bit-by-bit. When a complete set of bits have been stored, they are moved to the second receive buffer (SC0BUF). At the same time, the receive buffer full flag (SC0MOD2 “RBFL”) is set to “1” to indicate that valid data is stored in the second receive buffer. However, if the receive FIFO is set enabled, the receive data is moved to the receive FIFO and this flag is immediately cleared.

If the receive FIFO has been disabled (SC0FCNF <CNFG> = 0 and SC0MOD1<FDPX[1:0]> = 01), the INTRX0 interrupt is generated at the same time. If the receive FIFO has been enabled (SCNFCNF <CNFG> = 1 and SC0MOD1<FDPX[1:0]> = 01), an interrupt will be generated according to the SC0RFC <RIL[1:0]> setting.

The CPU will read the data from either the second receive buffer (SC0BUF) or from the receive FIFO (the address is the same as that of the receive buffer). If the receive FIFO has not been enabled, the receive buffer full flag <RBFL> is cleared to "0" by the read operation. The next data received can be stored in the first receive buffer even if the CPU has not read the previous data from the second receive buffer (SC0BUF) or the receive FIFO.

If SCLK is set to generate clock output in the I/O interface mode, the double buffer control bit SC0MOD2 <WBUF> can be programmed to enable or disable the operation of the second receive buffer (SC0BUF).

By disabling the second receive buffer (i.e., the double buffer function) and also disabling the receive FIFO (SC0FCNF <CNFG> = 0 and <FDPX[1:0]> = 01), handshaking with the other side of communication can be enabled and the SCLK output stops each time one frame of data is transferred. In this setting, the CPU reads data from the first receive buffer. By the read operation of CPU, the SCLK output resumes.

If the second receive buffer (i.e., double buffering) is enabled but the receive FIFO is not enabled, the SCLK output is stopped when the first receive data is moved from the first receive buffer to the second receive buffer and the next data is stored in the first buffer filling both buffers with valid data. When the second receive buffer is read, the data of the first receive buffer is moved to the second receive buffer and the SCLK output is resumed upon generation of the receive interrupt INTRX. Therefore, no buffer overrun error will be caused in the I/O interface SCLK output mode regardless of the setting of the double buffer control bit SC0MOD2 <WBUF>.

If the second receive buffer (double buffering) is enabled and the receive FIFO is also enabled (SCNFCNF <CNFG> = 1 and <FDPX[1:0]> = 01/11), the SCLK output will be stopped when the receive FIFO is full (according to the setting of SC0FCNF <RFST>) and both the first and second receive buffers contain valid data. Also in this case, if SC0FCNF <RXTXCNT> has been set to "1," the receive control bit RXE will be automatically cleared upon suspension of the SCLK output. If it is set to "0," automatic clearing will not be performed.

**(Note) In this mode, the SC0CR <OEER> flag is insignificant and the operation is undefined. Therefore, before switching from the SCLK output mode to another mode, the SC0CR register must be read to initialize this flag.**

In other operating modes, the operation of the second receive buffer is always valid, thus improving the performance of continuous data transfer. If the receive FIFO is not enabled, an overrun error occurs when the data in the second receive buffer (SC0BUF) has not been read before the first receive buffer is full with the next receive data. If an overrun error occurs, data in the first receive buffer will be lost while data in the second receive buffer and the contents of SC0CR <RB8> remain intact. If the receive FIFO is enabled, the FIFO must be read before the FIFO is full and the second receive buffer is written by the next data through the first buffer. Otherwise, an overrun error will be generated and the receive FIFO overrun error flag will be set. Even in this case, the data already in the receive FIFO remains intact.

The parity bit to be added in the 8-bit UART mode as well as the most significant bit in the 9-bit UART mode will be stored in SC0CR <RB8>.

In the 9-bit UART mode, the slave controller can be operated in the wake-up mode by

setting the wake-up function SC0MOD0 <WU> to “1.” In this case, the interrupt INTRX0 will be generated only when SC0CR <RB8> is set to “1.”

**11.3.7 Receive FIFO Buffer**

In addition to the double buffer function already described, data may be stored using the receive FIFO buffer. By setting <CNFG> of the SC0FCNF register and <FDPX[1:0]> of the SC0MOD1 register, the 4-byte receive buffer can be enabled. Also, in the UART mode or I/O interface mode, data may be stored up to a predefined fill level. When the receive FIFO buffer is to be used, be sure to enable the double buffer function.

If data with parity bit is to be received in the UART mode, parity check must be performed each time a data frame is received.

**11.3.8 Receive FIFO Operation**

① I/O interface mode with SCLK output:

The following example describes the case a 4-byte data stream is received in the half duplex mode:

SC0MOD1<[6:5]>=01: Sets the half duplex mode.

SC0FCNF <[4:0]>=10111: Automatically inhibits continued reception after reaching the fill level. The number of bytes to be used in the receive FIFO is the same as the interrupt generation fill level.

SC0RFC<[1:0]>=00: Sets the interrupt to be generated at fill level 4.

SC0RFC<[7:6]>=01: Clears receive FIFO and sets the condition of interrupt generation.

In this condition, 4-byte data reception may be initiated by setting the half duplex transmission mode and writing “1” to the RXE bit. After receiving 4 bytes, the RXE bit is automatically cleared and the receive operation is stopped (SCLK is stopped).

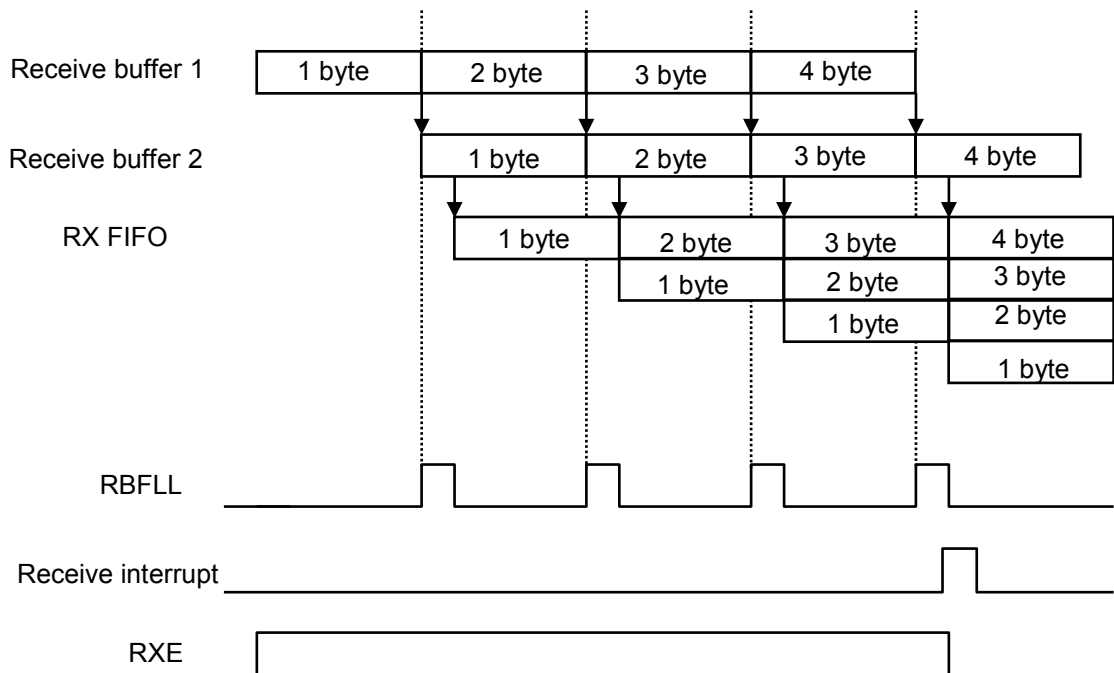

Fig. 11-3 Receive FIFO Operation

② I/O interface mode with SCLK input:

The following example describes the case a 4-byte data stream is received:

Data transmission can be initiated by setting the transfer mode to half duplex.

SC0MOD1<[6:5]>=01: Sets the half duplex mode.

SC0FCNF <[4:0]> = 10101: Automatically allows continued reception after reaching the fill level. The number of bytes to be used in the receive FIFO is the maximum allowable number.

SC0RFC <[1:0]> = 00: Sets the interrupt to be generated at fill level 4.

SC0RFC <[7:6]> = 10: Clears receive FIFO and sets the condition of interrupt generation

In this condition, 4-byte data reception may be initiated by writing “1” to the RXE bit. After receiving 4 bytes, receive FIFO interrupt is generated. This setting enables the next data reception as well. The next 4 bytes can be received before all the data is read from FIFO.

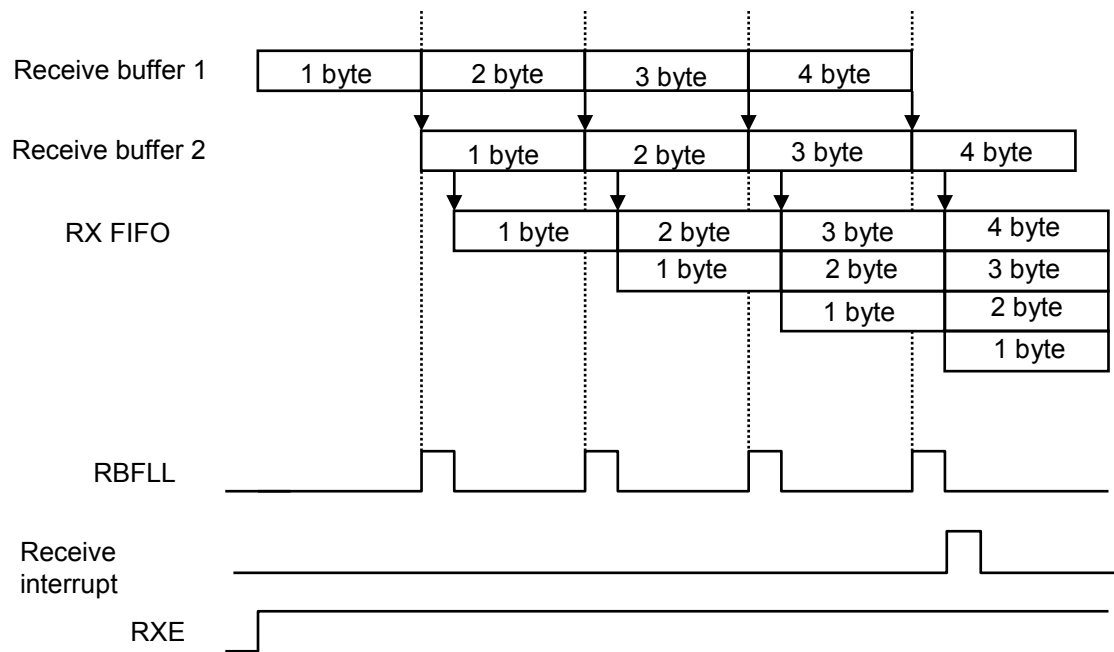

Fig. 11-4 Receive FIFO Operation

### 11.3.9 Transmit Counter

The transmit counter is a 4-bit binary counter used in the asynchronous communication (UART) mode. It is counted by SIOCLK as in the case of the receive counter and generates a transmit clock (TXDCLK) on every 16th clock pulse.

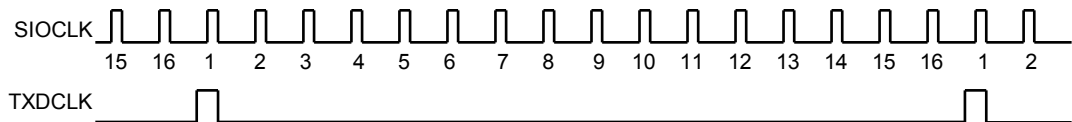

Fig. 11-5 Transmit Clock Generation

### 11.3.10 Transmit Control Unit

- I/O interface mode:

In the SCLK output mode with SC0CR <IOC> set to “0,” each bit of data in the transmit buffer is output to the TXD0 pin on the rising edge of the shift clock output from the SCLK0 pin.

In the SCLK input mode with SC0CR <IOC> set to “1,” each bit of data in the transmit buffer is output to the TXD0 pin on the rising or falling edge of the input SCLK signal according to the SC0CR <SCLKS> setting.

- Asynchronous (UART) mode:

When the CPU writes data to the transmit buffer, data transmission is initiated on the rising edge of the next TXDCLK and the transmit shift clock (TXDSFT) is also generated.

- Handshake function

The  $\overline{\text{CTS}}$  pin enables frame by frame data transmission so that overrun errors can be prevented. This function can be enabled or disabled by SC0MOD0 <CTSE>.

When the  $\overline{\text{CTS0}}$  pin is set to the “H” level, the current data transmission can be completed but the next data transmission is suspended until the  $\overline{\text{CTS0}}$  pin returns to the “L” level. However in this case, the INTTX0 interrupt is generated, the next transmit data is requested to the CPU, data is written to the transmit buffer, and it waits until it is ready to transmit data.

Although no  $\overline{\text{RTS}}$  pin is provided, a handshake control function can be easily implemented by assigning a port for the  $\overline{\text{RTS}}$  function. By setting the port to “H” level upon completion of data reception (in the receive interrupt routine), the transmit side can be requested to suspend data transmission.

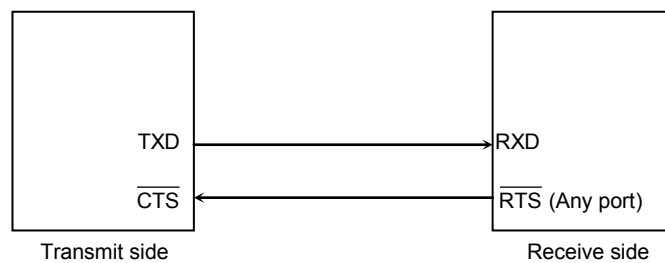

Fig. 11-6 Handshake Function

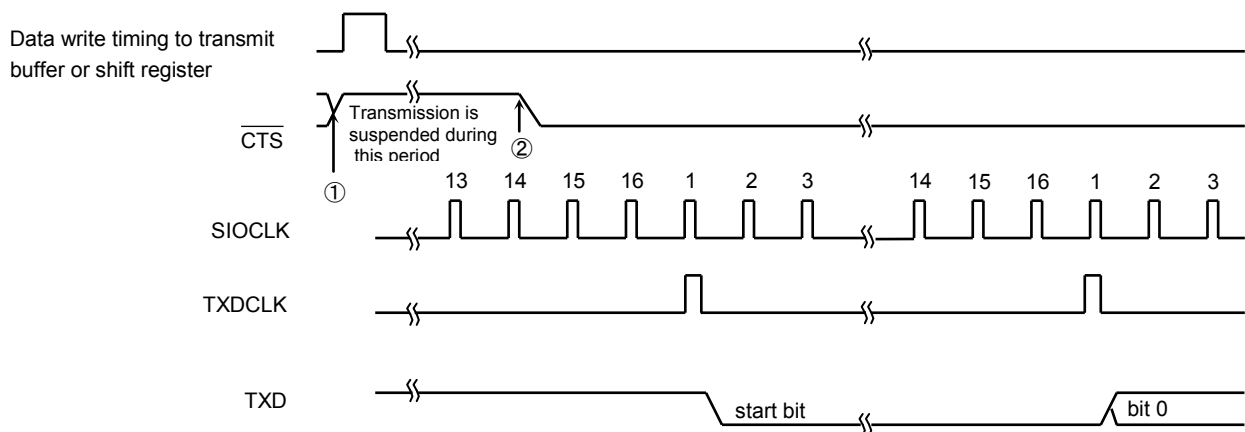

Fig. 11-7  $\overline{\text{CTS}}$  (Clear to Transmit) Signal Timing

**(Note 1)** If the  $\overline{\text{CTS}}$  signal is set to “H” during transmission, the next data transmission is suspended after the current transmission is completed.

**(Note 2)** Data transmission starts on the first falling edge of the TXDCLK clock after  $\overline{\text{CTS}}$  is set to “L.”

### 11.3.11 Transmit Buffer

The transmit buffer (SC0BUF) is in a dual structure. The double buffering function may be enabled or disabled by setting the double buffer control bit <WBUF> in serial mode control register 2 (SC0MOD2). If double buffering is enabled, data written to Transmit Buffer 2 (SC0BUF) is moved to Transmit Buffer 1 (shift register).

If the transmit FIFO has been disabled (SC0FCNF <CNFG> = 0 or 1 and SC0MOD1 <FDPX[1:0]> = 01), the INTTX0 interrupt is generated at the same time and the transmit buffer empty flag <TBEMP> of SC0MOD2 is set to "1." This flag indicates that Transmit Buffer 2 is now empty and that the next transmit data can be written. When the next data is written to Transmit Buffer 2, the <TBEMP> flag is cleared to "0."

If the transmit FIFO has been enabled (SCNFCNF <CNFG> = 1 and SC0MOD1 <FDPX[1:0]> = 10/11), any data in the transmit FIFO is moved to the Transmit Buffer 2 and <TBEMP> flag is immediately cleared to "0." The CPU writes data to Transmit Buffer 2 or to the transmit FIFO.

If the transmit FIFO is disabled in the I/O interface SCLK input mode and if no data is set in Transmit Buffer 2 before the next frame clock input, which occurs upon completion of data transmission from Transmit Buffer 1, an under-run error occurs and a serial control register (SC0CR) <PERR> parity/under-run flag is set.

If the transmit FIFO is enabled in the I/O interface SCLK input mode, when data transmission from Transmit Buffer 1 is completed, the Transmit Buffer 2 data is moved to Transmit Buffer 1 and any data in transmit FIFO is moved to Transmit Buffer 2 at the same time.

If the transmit FIFO is disabled in the I/O interface SCLK output mode, when data in Transmit Buffer 2 is moved to Transmit Buffer 1 and the data transmission is completed, the SCLK output stops. So, no under-run errors can be generated.

If the transmit FIFO is enabled in the I/O interface SCLK output mode, the SCLK output stops upon completion of data transmission from Transmit Buffer 1 if there is no valid data in the transmit FIFO.

**Note) In the I/O interface SCLK output mode, the SC0CR <PEER> flag is insignificant. In this case, the operation is undefined. Therefore, to switch from the SCLK output mode to another mode, SC0CR must be read in advance to initialize the flag.**

If double buffering is disabled, the CPU writes data only to Transmit Buffer 1 and the transmit interrupt INTTX0 is generated upon completion of data transmission.

If handshaking with the other side is necessary, set the double buffer control bit <WBUF> to "0" (disable) to disable Transmit Buffer 2; any setting for the transmit FIFO should not be performed.

### 11.3.12 Transmit FIFO Buffer

In addition to the double buffer function already described, data may be stored using the transmit FIFO buffer. By setting <CNFG> of the SC0FCNF register and <FDPX[1:0]> of the SC0MOD1 register, the 4-byte transmit buffer can be enabled. In the UART mode or I/O interface mode, up to 4 bytes of data may be stored.

If data is to be transmitted with a parity bit in the UART mode, parity check must be performed on the receive side each time a data frame is received.

**Note) When using transmit FIFO buffer, transmit FIFO buffer should be clear after setting the transfer mode to half duplex or full duplex and enable FIFO(setting SC0FCNF<CNFG>="1")**

### 11.3.13 Transmit FIFO Operation

- ① I/O interface mode with SCLK output (normal mode):

The following example describes the case a 4-byte data stream is transmitted:

Data transmission can be initiated by setting the transfer mode to half duplex.

SC0FCNF <[4:0]> = 01011: Inhibits continued transmission after reaching the fill level.

SC0TFC <[1:0]> = 00: Sets the interrupt to be generated at fill level 0.

SC0TFC <[7:6]> = 01: Clears transmit FIFO and sets the condition of interrupt generation

In this condition, data transmission can be initiated by writing 4 bytes of data to the transmit FIFO, and setting the <TXE> bit to "1." When the last transmit data is moved to the transmit buffer, the transmit FIFO interrupt is generated. When transmission of the last data is completed, the clock is stopped and the transmission sequence is terminated.

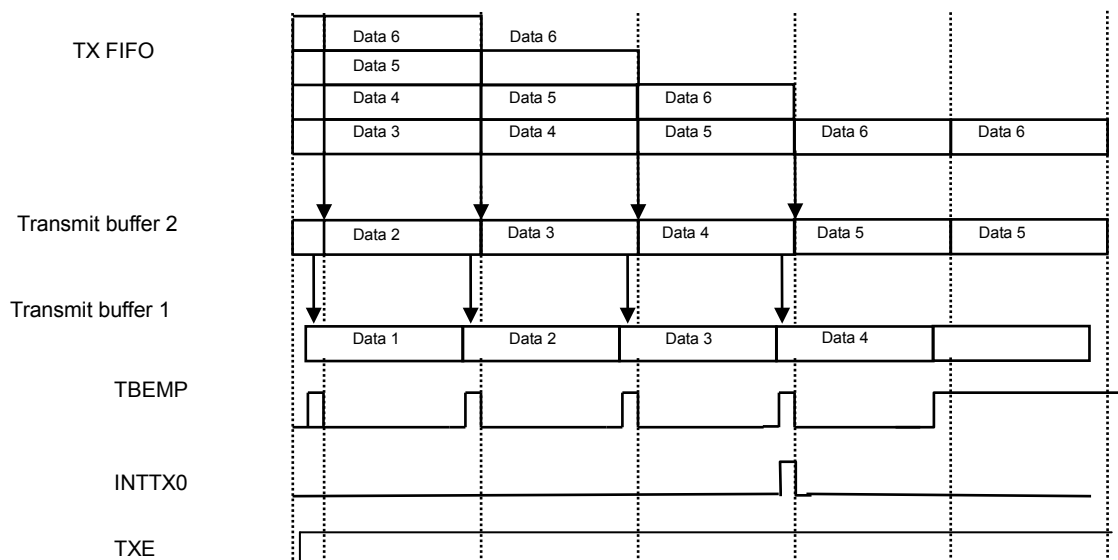

Fig. 11-8 Transmit FIFO Operation

② I/O interface mode with SCLK input (normal mode):

The following example describes the case a 4-byte data stream is transmitted:

Data transmission can be initiated by setting the transfer mode to half duplex.

SC0FCNF <[4:0]> = 01001: Allows continued transmission after reaching the fill level.

SC0TFC <[1:0]> = 01: Clears the transmit FIFO and sets the condition of interrupt generation.

SC0TFC <[7:6]> = 00: Sets the interrupt to be generated at fill level 0.

In this condition, data transmission can be initiated along with the input clock by setting the transfer mode to half duplex, writing 4 bytes of data to the transmit FIFO, and setting the <TXE> bit to "1." When the last transmit data is moved to the transmit buffer, the transmit FIFO interrupt is generated.

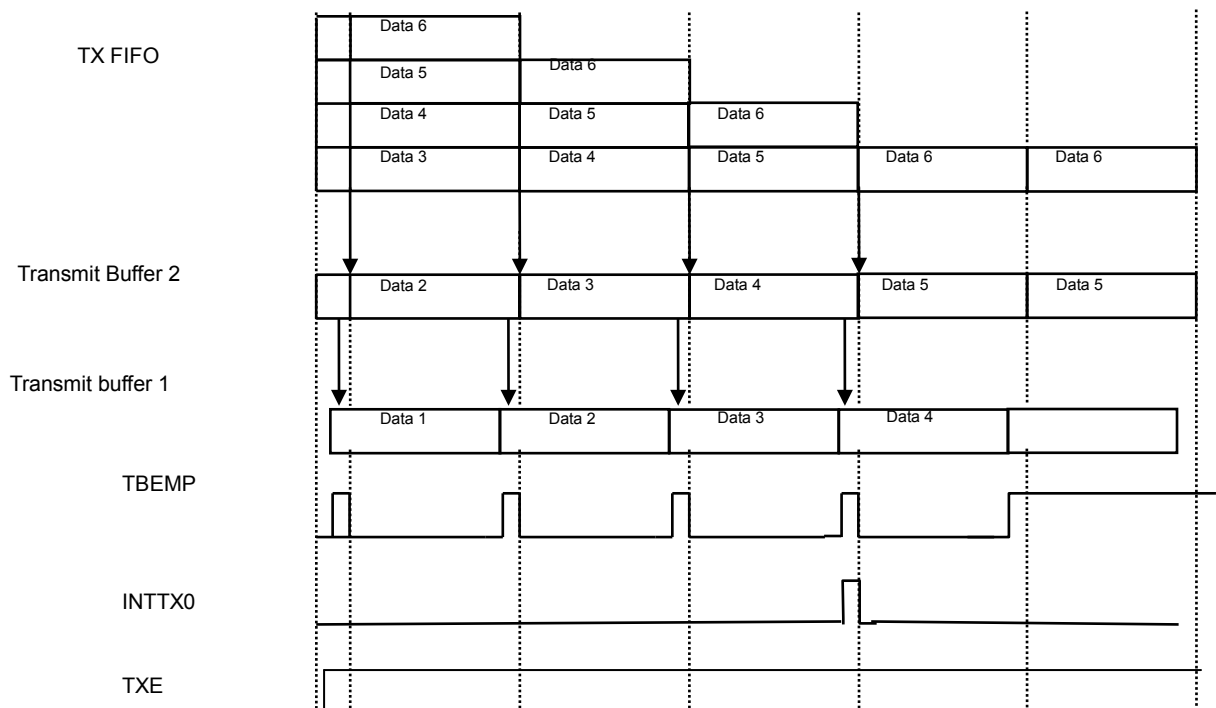

Fig. 11-9 Transmit FIFO Operation

### 11.3.14 Parity Control Circuit

If the parity addition bit <PE> of the serial control register SC0CR is set to “1,” data is sent with the parity bit. Note that the parity bit may be used only in the 7- or 8-bit UART mode. The <EVEN> bit of SC0CR selects either even or odd parity.

Upon data transmission, the parity control circuit automatically generates the parity with the data written to the transmit buffer (SC0BUF). After data transmission is complete, the parity bit will be stored in SC0BUF bit 7 <TB7> in the 7-bit UART mode and in bit 7 <TB8> in the serial mode control register SC0MOD in the 8-bit UART mode. The <PE> and <EVEN> settings must be completed before data is written to the transmit buffer.

Upon data reception, the parity bit for the received data is automatically generated while the data is shifted to receive buffer 1 and moved to receive buffer 2 (SC0BUF). In the 7-bit UART mode, the parity generated is compared with the parity stored in SC0BUF <RB7>, while in the 8-bit UART mode, it is compared with the bit 7 <RB8> of the SC0CR register. If there is any difference, a parity error occurs and the <PERR> flag of the SC0CR register is set.

In the I/O interface mode, the SC0CR <PERR> flag functions as an under-run error flag, not as a parity flag.

### 11.3.15 Error Flag

Three error flags are provided to improve the reliability of received data.

1. Overrun error <OERR>: Bit 4 of the serial control register SC0CR

In both UART and I/O interface modes, this bit is set to “1” when an error is generated by completing the reception of the next frame receive data before the receive buffer has been read. If the receive FIFO is enabled, the received data is automatically moved to the receive FIFO and no overrun error will be generated until the receive FIFO is full (or until the usable bytes are fully occupied). This flag is set to “0” when it is read. In the I/O interface SCLK output mode, no overrun error is generated and therefore, this flag is inoperative and the operation is undefined.

2. Parity error/under-run error <PERR>: Bit 3 of the SC0CR register

In the UART mode, this bit is set to “1” when a parity error is generated. A parity error is generated when the parity generated from the received data is different from the parity received. This flag is set to “0” when it is read.

In the I/O interface mode, this bit indicates an under-run error. When the double buffer control bit <WBUF> of the serial mode control register SC0MOD2 is set to “1” in the SCLK input mode, if no data is set to the transmit double buffer before the next data transfer clock after completing the transmission from the transmit shift register, this error flag is set to “1” indicating an under-run error. If the transmit FIFO is enabled, any data content in the transmit FIFO will be moved to the buffer. When the transmit FIFO and the double buffer are both empty, an under-run error will be generated. Because no under-run errors can be generated in the SCLK output mode, this flag is inoperative and the operation is undefined. If Transmit Buffer 2 is disabled, the under-run flag <PERR> will not be set. This flag is set to “0” when it is read.

### 3. Framing error <FERR>: Bit 2 of the SC0CR register

In the UART mode, this bit is set to “1” when a framing error is generated. This flag is set to “0” when it is read. A framing error is generated if the corresponding stop bit is determined to be “0” by sampling the bit at around the center. Regardless of the <SBLN> (stop bit length) setting of the serial mode control register 2, SC0MOD2, the stop bit status is determined by only 1 bit on the receive side.

Operation mode	Error flag	Function
UART	OERR	Overrun error flag
	PERR	Parity error flag
	FERR	Framing error flag
I/O Interface (SCLK input)	OERR	Overrun error flag
	PERR	Underrun error flag (WBUF = 1)
		Fixed to 0 (WBUF = 0)
FERR	Fixed to 0	
I/O Interface (SCLK output)	OERR	Operation undefined
	PERR	Operation undefined
	FERR	Fixed to 0

#### 11.3.16 Direction of Data Transfer

In the I/O interface mode, the direction of data transfer can be switched between “MSB first” and “LSB first” by the data transfer direction setting bit <DRCHG> of the SC0MOD2 serial mode control register 2. Don't switch the direction when data is being transferred.

#### 11.3.17 Stop Bit Length

In the UART transmission mode, the stop bit length can be set to either 1 or 2 bits by bit 4 <SBLN> of the SC0MOD2 register.

#### 11.3.18 Status Flag

If the double buffer function is enabled (SC0MOD2 <WBUF> = “1”), the bit 6 flag <RBFLL> of the SC0MOD2 register indicates the condition of receive buffer full. When one frame of data has been received and transferred from buffer 1 to buffer 2, this bit is set to “1” to show that buffer 2 is full (data is stored in buffer 2). When the receive buffer is read by CPU/DMAC, it is cleared to “0.” If <WBUF> is set to “0,” this bit is insignificant and must not be used as a status flag. When double buffering is enabled (SC0MOD2 <WBUF> = “1”), the bit 7 flag <TBEMP> of the SC0MOD2 register indicates that Transmit Buffer 2 is empty. When data is moved from Transmit Buffer 2 to Transmit Buffer 1 (shift register), this bit is set to “1” indicating that Transmit Buffer 2 is now empty. When data is set to the transmit buffer by CPU/DMAC, the bit is cleared to “0.” If <WBUF> is set to “0,” this bit is insignificant and must not be used as a status flag.

### 11.3.19 Configurations of Transmit/Receive Buffer

		<WBUF> = 0	<WBUF> = 1
UART	Transmit buffer	Single	Double
	Receive buffer	Double	Double
I/O Interface (SCLK input)	Transmit buffer	Single	Double
	Receive buffer	Double	Double
I/O Interface (SCLK output)	Transmit buffer	Single	Double
	Receive buffer	Single	Double

### 11.3.20 Software reset

Software reset is generated by writing the bits 1 and 0 of SC0MOD2 <SWRST[1:0]> as “10” followed by “01”. As a result, SC0MOD0<RXE>, SC0MOD1<TXE>, SC0MOD2<TBEMP>, <RBFL>, <TXRUN> of mode registers and SC0CR<OERR>, <PERR>, <FERR> of control registers and internal circuit is initialized. Other states are maintained.

### 11.3.21 Signal Generation Timing

#### ① UART Mode:

##### Receive Side

Mode	9-bit	8-bit with parity	8-bit, 7-bit, and 7-bit with parity
Interrupt generation timing	Around the center of the 1st stop bit	Around the center of the 1st stop bit	Around the center of the 1st stop bit
Framing error generation timing	Around the center of the stop bit	Around the center of the stop bit	Around the center of the stop bit
Parity error generation timing	—	Around the center of the last (parity) bit	Around the center of the last (parity) bit
Overrun error generation timing	Around the center of the stop bit	Around the center of the stop bit	Around the center of the stop bit

##### Transmit Side

Mode	9-bit	8-bit with parity	8-bit, 7-bit, and 7-bit with parity
Interrupt generation timing (<WBUF> = 0)	Just before the stop bit is sent	Just before the stop bit is sent	Just before the stop bit is sent
Interrupt generation timing (<WBUF> = 1)	Immediately after data is moved to transmit buffer 1 (just before start bit transmission)	Immediately after data is moved to transmit buffer 1 (just before start bit transmission).	Immediately after data is moved to transmit buffer 1 (just before start bit transmission)

#### ② I/O interface mode:

##### Receive Side

Interrupt generation timing (<WBUF> = 0)	SCLK output mode	Immediately after the rising edge of the last SCLK
	SCLK input mode	Immediately after the rising or falling edge of the last SCLK (for rising or falling edge mode, respectively).
Interrupt generation timing (<WBUF> = 1)	SCLK output mode	Immediately after the rising edge of the last SCLK (just after data transfer to receive buffer 2) or just after receive buffer 2 is read.
	SCLK input mode	Immediately after the rising edge or falling edge of the last SCLK (right after data is moved to receive buffer 2).
Overrun error generation timing	SCLK input mode	Immediately after the rising or falling edge of the last SCLK (for rising or falling edge mode, respectively)

##### Transmit Side

Interrupt generation timing (<WBUF> = 0)	SCLK output mode	Immediately after the rising edge of the last SCLK
	SCLK input mode	Immediately after the rising or falling edge of the last SCLK (for rising or falling edge mode, respectively)
Interrupt generation timing (<WBUF> = 1)	SCLK output mode	Immediately after the rising edge of the last SCLK or just after data is moved to Transmit Buffer 1
	SCLK input mode	Immediately after the rising or falling edge of the last SCLK or just after data is moved to Transmit Buffer 1
Under-run error generation timing	SCLK input mode	Immediately after the falling or rising edge of the next SCLK

**(Note 1) Do not modify any control register when data is being sent or received (in a state ready to transmit or receive).**

**(Note 2) Do not stop the receive operation (by setting SC0MOD0 <RXE> = "0") when data is being received.**

**(Note 3) Do not stop the transmit operation (by setting SC0MOD1 <TXE> = "0") when data is being transmitted.**

## 11.4 Register Description (Only for Channel 0)

The channel 0 registers are described here. Each register for all the channels operates in the same way.

### 11.4.1 Enable register

	7	6	5	4	3	2	1	0	
SC0EN									SIOE
bit Symbol									
Read/Write									R/W
After reset									0
Function	"0" is read.								SIO operation 0: disabled 1: enabled

<SIOE>: Specified the SIO operation.  
To use the SIO, enable the SIO operation.  
When the operation is disabled, no clock is supplied to the other registers in the SIO module.  
This can reduce the power consumption.  
If the SIO operation is executed and then disabled, the settings will be maintained in each register except SC0TFC[1:0].

**(Note)** In case that SCxEN<SIOE>="0" (Stop SIO operation) or the operation mode is changed to IDLE mode with SCxMOD1<I2SC>="0" (Stop SIO operation in IDLE mode), SCxTFC is initialized again.

### 11.4.2 Buffer register



SC0BUF works as a transmit buffer for WR operation and as a receive buffer for RD operation.

	7	6	5	4	3	2	1	0
SC0BUF	TB7/RB7	TB6/RB6	TB5/RB5	TB4/RB4	TB3/RB3	TB2/RB2	TB1/RB1	TB0/RB0
bit Symbol								
Read/Write	R/W							
After reset	0	0	0	0	0	0	0	0
Function	TB7~0 : Transmit buffer/FIFO RB7~0 : Receive buffer/FIFO							

<TB[7:0]> Transmit buffer (at WR operation).

<RB[7:0]> Receive buffer (at RD operation).

11.4.3 Control register

	7	6	5	4	3	2	1	0
bit Symbol	RB8	EVEN	PE	OERR	PERR	FERR	SCLKS	IOC
Read/Write	R	R/W		R (Cleared to "0" when read)			R/W	
After reset	0	0	0	0	0	0	0	0
Function	Receive data bit 8 (For UART)	Parity (For UART) 0: Odd 1: Even	Add parity (For UART) 0: Disabled 1: Enabled	0: Normal operation 1: Error  Overrun      Parity/underrun      Framing			0: SCLK0  1: SCLK0 	(For I/O interface) 0: Baud rate generator 1: SCLK0 pin input

<RB8>: 9<sup>th</sup> bit of the received data in the 9 bits UART mode.

<EVEN>: Selects even or odd parity.  
 "0": odd parity.  
 "1": even parity.  
 The parity bit may be used only in the 7- or 8-bit UART mode.

<PE>: Controls enabling/ disabling parity.  
 The parity bit may be used only in the 7- or 8-bit UART mode.

<OERR>: Error flag (see note)  
 <PERR>: Indicate overrun error, parity error, underrun error and framing error.  
 <FERR>:

<SCLKS>: Selecting input clock edge (For I/O Interface)  
 Set to "0" in the clock output mode.

0:Data in the transmit buffer is sent to TXDx pin one bit at a time on the falling edge of SCLKx. Data from RXDx pin is received in the receive buffer one bit at a time on the rising edge of SCLKx. In this case, the SCLKx starts from high level.

1:Data in the transmit buffer is sent to TXDx pin one bit at a time on the rising edge of SCLKx. Data from RXDx pin is received in the receive buffer one bit at a time on the falling edge of SCLKx. In this case, the SCLKx starts from low level.

<IOC>: Selects input clock in the I/O interface mode.  
 "0": baud rate generator  
 "1": SCLK0 pin input.

**(Note) Any error flag is cleared when read.**

11.4.4 Mode control register 0

		7	6	5	4	3	2	1	0
	bit Symbol	TB8	CTSE	RXE	WU	SM1	SM0	SC1	SC0
	Read/Write	R/W							
SC0MOD0	After reset	0	0	0	0	0	0	0	0
	Function	Transmit data bit 8	Handshake function control 0: CTS disable 1: CTS enable	Receive control 0: Reception disabled 1: Reception enabled	Wake-up function 0: Reception disabled 1: Reception enabled	Serial transfer mode 00: I/O interface mode 01: 7-bit length UART mode 10: 8-bit length UART mode 11: 9-bit length UART mode	Serial transfer clock <b>(for UART)</b> 00: Timer TB9OUT 01: Baud rate generator 10: Internal clock f <sub>SYS</sub> 11: External clock (SCLK0 input)		

<TB8>: Writes the 9<sup>th</sup> bit of transmit data in the 9 bits UART mode.

<CTSE>: Controls handshake function.  
Setting "1" enables handshake function using  $\overline{\text{CTS}}$  pin.

<RXE>: Controls reception (**see note**).  
Set <RXE> after setting each mode register (SC0MOD0, SC0MOD1 and SC0MOD2).

<WU>: Controls wake-up function.  
This function is available only at 9-bit UART mode.

	9-bit UART mode		Other modes
0	Interrupt when received		don't care
1	Interrupt only when RB9=1		

<SM[1:0]>: Specifies transfer mode.

<SC[1:0]>: Selects the serial transfer clock in the UART mode.  
As for the I/O interface mode, the serial transfer clock can be set in the control register SC0CR.

**(Note)** With <RXE> set to "0," set each mode register (SC0MOD0, SC0MOD1 and SC0MOD2). Then set <RXE> to "1."

## 11.4.5 Mode control register 1

		7	6	5	4	3	2	1	0
bit Symbol		I2S0	FDPX1	FDPX0	TXE	SINT2	SINT1	SINT0	-
Read/Write		R/W	R/W	R/W	R/W	R/W	R/W	R/W	R/W
After reset		0	0	0	0	0	0	0	0
Function		IDLE 0: Stop 1: Start	Transfer mode setting 00: Transfer prohibited 01: Half duplex(RX) 10: Half duplex(TX) 11: Full duplex		Transmit control 0: Disable 1: Enabled	Interval time of continuous transmission <b>(for I/O interface)</b> 000: None 100: 8SCLK 001: 1SCLK 101: 16SCLK 010: 2SCLK 110: 32SCLK 011: 4SCLK 111: 64SCLK			Write "0".

<I2S0>: Specifies the IDLE mode operation.

<FDPX[1:0]>: Configures the transfer mode in the I/O interface mode. Also configures the FIFO if it is enabled. In the UART mode, it is used only to specify the FIFO configuration.

<TXE>: This bit enables transmission and is valid for all the transfer modes (**see note**). If disabled while transmission is in progress, transmission is inhibited only after the current frame of data is completed for transmission.

<SINT[2:0]>: Specifies the interval time of continuous transmission when double buffering or FIFO is enabled in the I/O interface mode. This parameter is valid only for the I/O interface mode when SCLK0 pin input is not selected.

**(Note 1)** Specify the mode first and then specify the <TXE> bit.

**(Note 2)** In case that SCxEN<SIOE>="0" (Stop SIO operation) or the operation mode is changed to IDLE mode with SCxMOD1<I2SC>="0" (Stop SIO operation in IDLE mode), SCxTFC is initialized again.

11.4.6 Mode control register 2

	7	6	5	4	3	2	1	0
bit Symbol	TBEMP	RBFL	TXRUN	SBLN	DRCHG	WBUF	SWRST1	SWRST0
Read/Write	R			R/W			W	
After reset	1	0	0	0	0	0	0	0
Function	Transmit buffer empty flag 0: full 1: Empty	Receive Buffer full flag 0: Empty 1: full	In transmission flag 0: Stop 1: Start	STOP bit (for UART) 0: 1-bit 1: 2-bit	Setting transfer direction 0: LSB first 1: MSB first	W-buffer 0: Disabled 1: Enabled	SOFT RESET Overwrite "01" on "10" to reset.	

<TBEMP>: This flag shows that the transmit double buffers are empty. When data in the transmit double buffers is moved to the transmit shift register and the double buffers are empty, this bit is set to "1." Writing data again to the double buffers sets this bit to "0." If double buffering is disabled, this flag is insignificant.

<RBFL>: This is a flag to show that the receive double buffers are full. When a receive operation is completed and received data is moved from the receive shift register to the receive double buffers, this bit changes to "1" while reading this bit changes it to "0." If double buffering is disabled, this flag is insignificant.

<TXRUN>: This is a status flag to show that data transmission is in progress. <TXRUN> and <TBEMP> bits indicate the following status.

<TXRUN>	<TBEMP>	Status
1	-	Transmission in progress
0	1	Transmission completed
	0	Wait state with data in TX buffer

<SBLN>: This specifies the length of stop bit transmission in the UART mode. On the receive side, the decision is made using only a single bit regardless of the <SBLN> setting.

<DRCHG>: Specifies the direction of data transfer in the I/O interface mode. In the UART mode, it is fixed to LSB first.

<WBUF>: This parameter enables or disables the transmit/receive buffers to transmit (in both SCLK output/input modes) and receive (in SCLK output mode) data in the I/O interface mode and to transmit data in the UART. When receiving data in the I/O interface mode (I SCLK input) and UART mode, double buffering is enabled in both cases that 0 or 1 is set to <WBUF> bit.

<SWRST[1:0]>: Overwriting "01" in place of "10" generates a software reset. When this software reset is executed, the following bits and their internal circuits are initialized (**see note 1, 2 and 3**).

Register	Bit
SC0MOD0	RXE
SC0MOD1	TXE
SC0MOD2	TBEMP, RBFL, TXRUN,
SC0CR	OERR, PERR, FERR

- (Note 1) While data transmission is in progress, any software reset operation must be executed twice in succession.
- (Note 2) A software reset requires 2 clocks-duration at the time between the end of recognition and the start of execution of software reset instruction.
- (Note 3) A software reset initializes other bits. Resetting a mode register and a control register are needed.

**11.4.7 Baud rate generator control register(SC0BRCR)  
Baud rate generator control register 2(SC0BRADD)**

		7	6	5	4	3	2	1	0	
SC0BRCR	bit Symbol	-	BR0ADDE	BR0CK1	BR0CK0	BR0S3	BR0S2	BR0S1	BR0S0	
	Read/Write	R/W								
	After reset	0	0	0	0	0	0	0	0	
	Function	Write "0".	N + (16 - K)/16 divider function 0: disabled 1: enabled	Select input clock to the baud rate generator 00: φT1 01: φT4 10: φT16 11: φT64	Division ratio "N" 0000: 16 0001: 1 0010: 2 : 1111: 15					
		7	6	5	4	3	2	1	0	
SC0BRADD	bit Symbol					BR0K3	BR0K2	BR0K1	BR0K0	
	Read/Write	R				R/W				
	After reset	0				0	0	0	0	
	Function	"0" is read.				Specify K for the "N + (16 - K)/16" division 0000: Prohibited 0001: K=1 0010: K=2 : 1111: K=15				

<RB0ADDE>: Specifies N + (16-K)/16 division function.  
N + (16-K)/16 division function can only be used in the UART mode.

<RB0CK[1:0]>: Specifies the baud rate generator input clock.

<RB0S[3:0]>: Specifies division ratio "N".

<RB0K[3:0]>: Specifies K for the "N+(16-K)/16" division.

The division ratio of the baud rate generator can be specified in the registers shown above. Table 11-6 lists the settings of baud rate generator division ratio.

Table 11-6 Setting division ratio

	BR0ADDE=0	BR0ADDE=1 (Note 1) (Only UART)
BR0S	Specify "N" (Note 2) (Note 3)	
BR0K	No setting required	Setting "K" (Note 4)
Division ratio	Divide by N	$N + \frac{(16-K)}{16}$ division

- (Note 1) To use the " $N + (16 - K)/16$ " division function, be sure to set BR0K <BR0ADDE> to "1" after setting the K value to BR0K. The " $N + (16 - K)/16$ " division function can only be used in the UART mode.
- (Note 2) The division ratio "1" of the baud rate generator can be specified only when
- the " $N + (16 - K)/16$ " division function is not used in the UART mode.
  - double buffering is used in the I/O interface mode.
- (Note 3) As a division ratio, 1 ("0001") or 16 ("0000") cannot be applied to N when using the " $N + (16 - K)/16$ " division function.
- (Note 4) Specifying "K = 0" is prohibited.

11.4.8 FIFO configuration register

	7	6	5	4	3	2	1	0
bit Symbol	Reserved	Reserved	Reserved	RFST	TFIE	RFIE	RXTXCNT	CNFG
Read/Write	R/W							
After reset	0	0	0	0	0	0	0	0
Function	<b>Be sure to write "000".</b>			Bytes used in RX FIFO 0: Maximum 1: Same as FILL level of RX FIFO	TX interrupt for TX FIFO 0: Disabled 1: Enabled	RX interrupt for RX FIFO 0: Disabled 1: Enabled	Automatic disable of RXE/TXE 0: None 1: Auto disable	FIFO enable 0: Disabled 1: Enabled

<RFST>: When RX FIFO is enabled, the number of RX FIFO bytes to be used is selected (**see note**).

0: The maximum number of bytes of the FIFO configured (see also <CNFG>).  
1: Same as the fill level for receive interrupt generation specified by SC0RFC <RIL1:0>.

<TFIE>: When TX FIFO is enabled, transmit interrupts are enabled or disabled by this parameter.

<RFIE>: When RX FIFO is enabled, receive interrupts are enabled or disabled by this parameter.

<RXTXCNT>: Controls automatic disabling of transmission and reception. The mode control register SCOMOD1 <FDPX[1:0]> is used to set the types of TX/RX. Setting "1" enables to operate as follows.

Half duplex RX	When the RX FIFO is filled up to the specified number of valid bytes, SC0MOD0<RXE> is automatically set to "0" to inhibit further reception.
Half duplex TX	When the TX FIFO is empty, SC0MOD1<TXE> is automatically set to "0" to inhibit further transmission.
Full duplex	When either of the above two conditions is satisfied, TXE/RXE are automatically set to "0" to inhibit further transmission and reception.

<CNFG>: Enables FIFO. If enabled, the SCOMOD1 <FDPX1:0> setting automatically configures FIFO as follows: (The type of TX/RX can be specified in the mode control register 1 SCOMOD1<FDPX1:0>).

Half duplex RX	RX FIFO 4byte
Half duplex TX	TX FIFO 4byte
Full duplex	RX FIFO 2byte + TX FIFO 2byte

**(Note) Regarding TX FIFO, the maximum number of bytes being configured is always available. The available number of bytes is the bytes already written to the TX FIFO.**

11.4.9 RX FIFO configuration register

	7	6	5	4	3	2	1	0
bit Symbol	RFCS	RFIS					RIL1	RIL0
Read/Write	W	R/W	R				R/W	
After reset	0	0	0				0	0
Function	RX FIFO clear 1: Clear "0" is read.	Select interrupt generation condition 0: when the data reaches to the specified fill level. 1: when the data reaches to the specified fill level or the data exceeds the specified fill level at the time data is read.	"0" is read.				FIFO fill level to generate RX interrupts 00:4byte(2 Byte at full duplex) 01:1byte 10:2byte 11:3byte	

<RFCS>: Clears RX FIFO  
When SCxRFC<RFCS> is set to "1", the receive FIFO is cleared and SCxRST<RLVL> is "000". And also the read pointer is initialized.

<RFIS>: Specifies the condition of interrupt generation.  
0: An interrupt is generated when it reaches to the specified fill level.  
An interrupt is generated when it is reaches to the specified fill level or if it exceeds the specified fill level at the time data is read.

<RIL[1:0]>: Specifies FIFO fill level(see note).

	Other than full duplex	Full duplex
00	4byte	2byte
01	1byte	1byte
10	2byte	2byte
11	3byte	1byte

**(Note) RIL1 is ignored when FDPX[1:0] = 11 (full duplex)**

11.4.10 TX FIFO configuration register

	7	6	5	4	3	2	1	0
bit Symbol	TFCS	TFIS					TIL1	TIL0
Read/Write	W	R/W	R				R/W	
After reset	0	0	0				0	0
Function	TX FIFO clear 1:Clear Always reads "0".	Select interrupt generation condition 0: when the data reaches to the specified fill level. 1: when the data reaches to the specified fill level or the data cannot reach the specified fill level at the time new data is read.	"0" is read.				FIFO fill level to generate TX interrupts. 00:Empty 01:1byte 10:2byte 11:3byte Note: TIL1 is ignored when FDPX1:0=11 (full duplex).	

<TFCS>: Clears TX FIFO.  
When SCxTST<TFCS> is set to "1", the transmit FIFO is cleared and SCxTST<TLVL> is "000". And also the write pointer is initialized.

<TFIS>: Selects interrupt generation condition.  
0: An interrupt is generated when the data reaches to the specified fill level.  
1: An interrupt is generated when the data reaches to the specified fill level or the data cannot reach the specified fill level at the time new data is read.

<TIL[1:0]>: Selects FIFO fill level (see note).

	Other than full duplex	Full duplex
00	Empty	Empty
01	1byte	1byte
10	2byte	Empty
11	3byte	1byte

(Note1) TIL1 is ignored when FDPX[1:0] = 11 (full duplex).  
 (Note2) When setting SC0EN<0>=0 (SIO function disable, clock stop) or shifting standby mode(IDLE,SLEEP,STOP)(function disable in standby mode, clock stop), setting SC0TFC register again.

11.4.11 RX FIFO status register

		7	6	5	4	3	2	1	0
SC0RST	bit Symbol	ROR					RLVL2	RLVL1	RLVL0
	Read/Write	R	R				R		
	After reset	0	0				0	0	0
	Function	RX FIFO Overflow  1: Generated	"0" is read.				Status of RX FIFO fill level 000:Empty 001:1Byte 010:2Byte 011:3Byte 100:4Byte		

<ROR>: Flags for RX FIFO overrun. When the overrun occurs, these bits are set to "1" (see note).

<RLVL[2:0]>: Shows the fill level of RX FIFO.

**(Note)** The <ROR> bit is cleared to "0" when receive data is read from the SC0BUF register.

11.4.12 TX FIFO status register

		7	6	5	4	3	2	1	0
SC0TST	bit Symbol	TUR					TLVL2	TLVL1	TLVL0
	Read/Write	R	R				R		
	After reset	1	0				0	0	0
	Function	TX FIFO Under run 1:Generated Cleared by writing FIFO	"0" is read.				Status of TX FIFO fill level 000:Empty 001:1Byte 010:2Byte 011:3Byte 100:4Byte		

<TUR>: Flags for TX FIFO underrun. When the underrun occurs, these bits are set to "1" (see note).

<TLVL[2:0]>: Shows the fill level of TX FIFO.

**(Note)** The <TUR> bit is cleared to "0" when transmit data is written to the SC0BUF register.

## 11.5 Operation in Each Mode

### 11.5.1 Mode 0 (I/O interface mode)

Mode 0 consists of two modes, the “SCLK output” mode to output synchronous clock and the “SCLK input” mode to accept synchronous clock from an external source. The following operational descriptions are for the case use of FIFO is disabled. For details of FIFO operation, refer to the previous sections describing receive/transmit FIFO functions.

① Transmitting data

SCLK output mode

In the SCLK output mode, if SC0MOD2<WBUF> is set to “0” and the transmit double buffers are disabled, 8 bits of data are output from the TXD0 pin and the synchronous clock is output from the SCLK0 pin each time the CPU writes data to the transmit buffer. When all data is output, the INTTX0 interrupt is generated.

If SC0MOD2 <WBUF> is set to “1” and the transmit double buffers are enabled, data is moved from Transmit Buffer 2 to Transmit Buffer 1 when the CPU writes data to Transmit Buffer 2 while data transmission is halted or when data transmission from Transmit Buffer 1 (shift register) is completed. When data is moved from Transmit Buffer 2 to Transmit Buffer 1, the transmit buffer empty flag SC0MOD2 <TBEMP> is set to “1,” and the INTTX0 interrupt is generated. If Transmit Buffer 2 has no data to be moved to Transmit Buffer 1, the INTTX0 interrupt is not generated and the SCLK0 output stops.

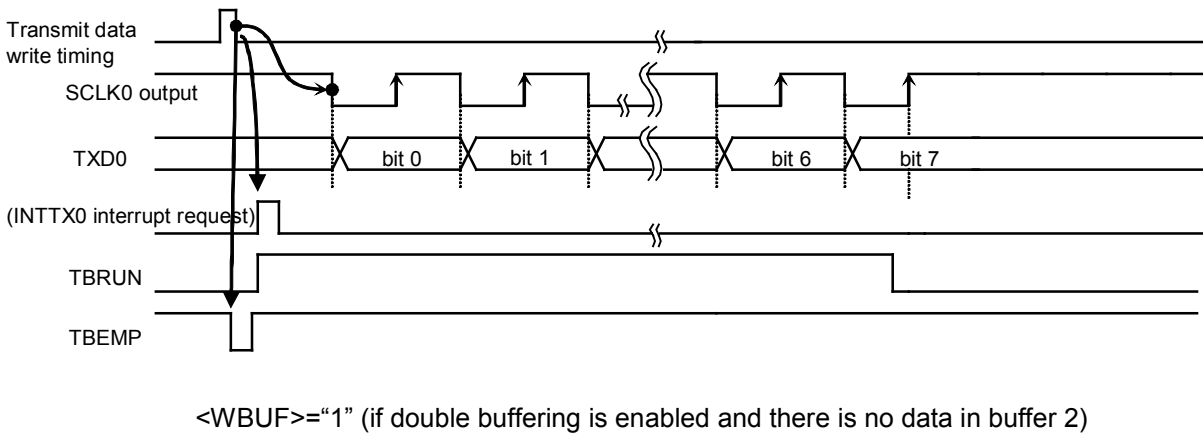
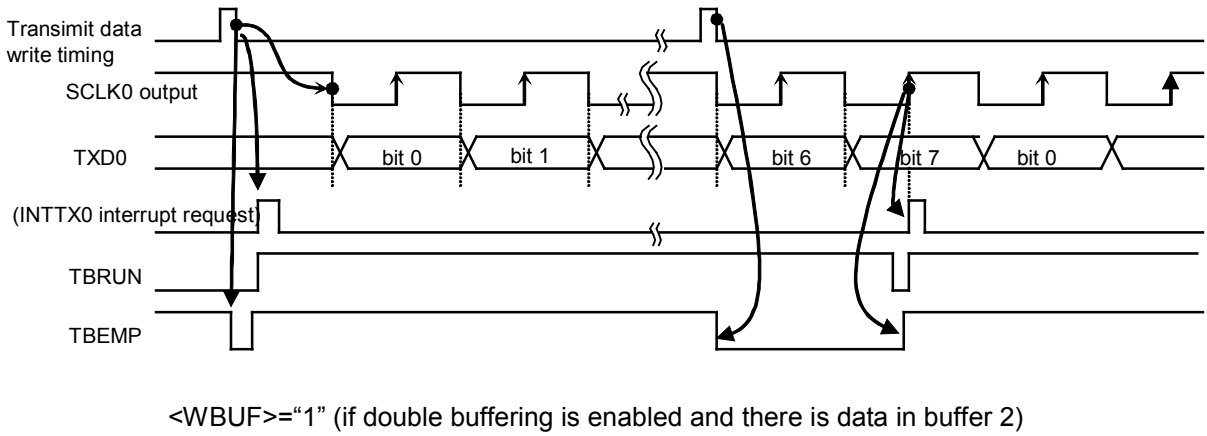
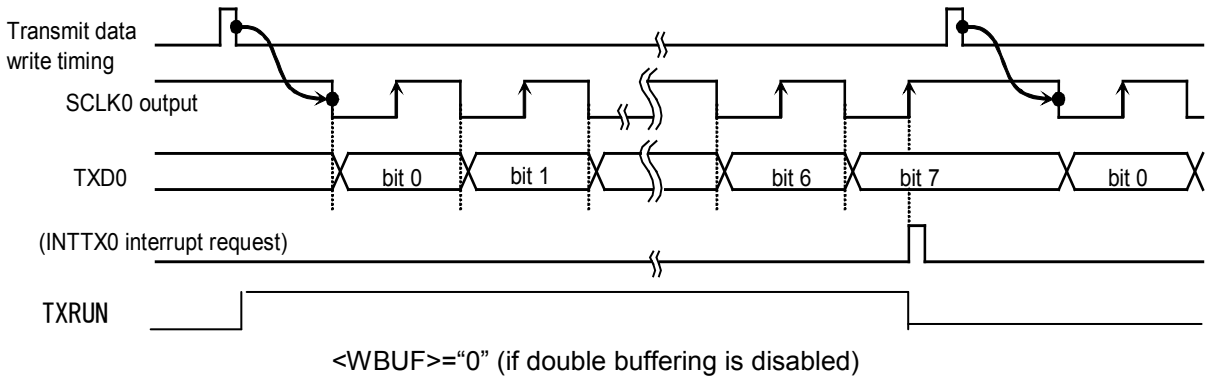
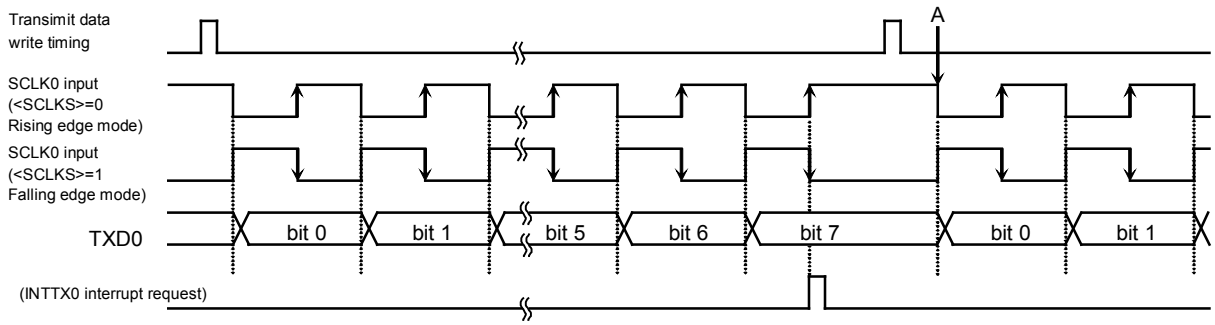

Fig. 11-10 Transmit Operation in the I/O Interface Mode (SCLK0 Output Mode)

### SCLK input mode

In the SCLK input mode, if SC0MOD2 <WBUF> is set to “0” and the transmit double buffers are disabled, 8-bit data that has been written in the transmit buffer is output from the TXD0 pin when the SCLK0 input becomes active. When all 8 bits are sent, the INTTX0 interrupt is generated. The next transmit data must be written before the timing point “A” as shown in Fig. 11-11.

If SC0MOD2 <WBUF> is set to “1” and the transmit double buffers are enabled, data is moved from Transmit Buffer 2 to Transmit Buffer 1 when the CPU writes data to Transmit Buffer 2 before the SCLK0 becomes active or when data transmission from Transmit Buffer 1 (shift register) is completed. As data is moved from Transmit Buffer 2 to Transmit Buffer 1, the transmit buffer empty flag SC0MOD2 <TBEMP> is set to “1” and the INTTX0 interrupt is generated. If the SCLK0 input becomes active while no data is in Transmit Buffer 2, although the internal bit counter is started, an under-run error occurs and 8-bit dummy data (FFh) is sent.



<WBUF>="0" (if double buffering is disabled)

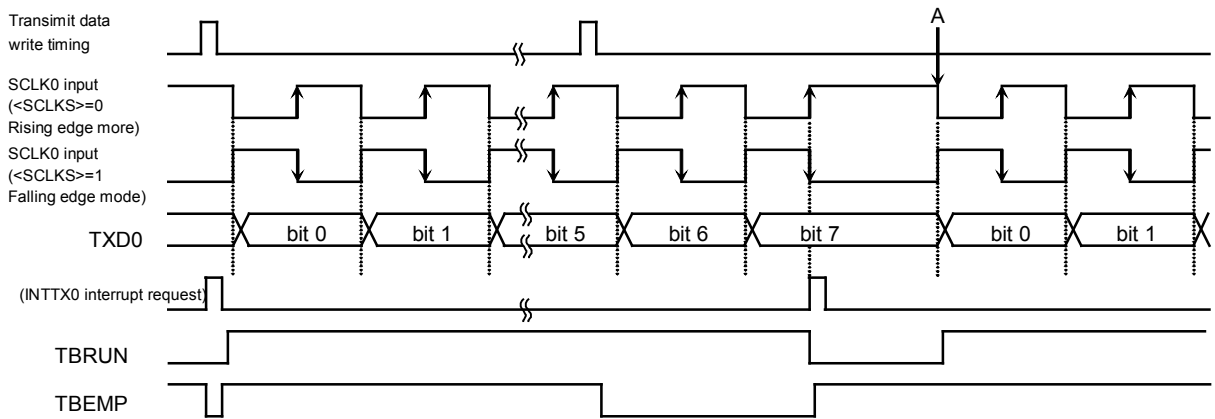

<WBUF>="1" (if double buffering is enabled and there is data in buffer 2)

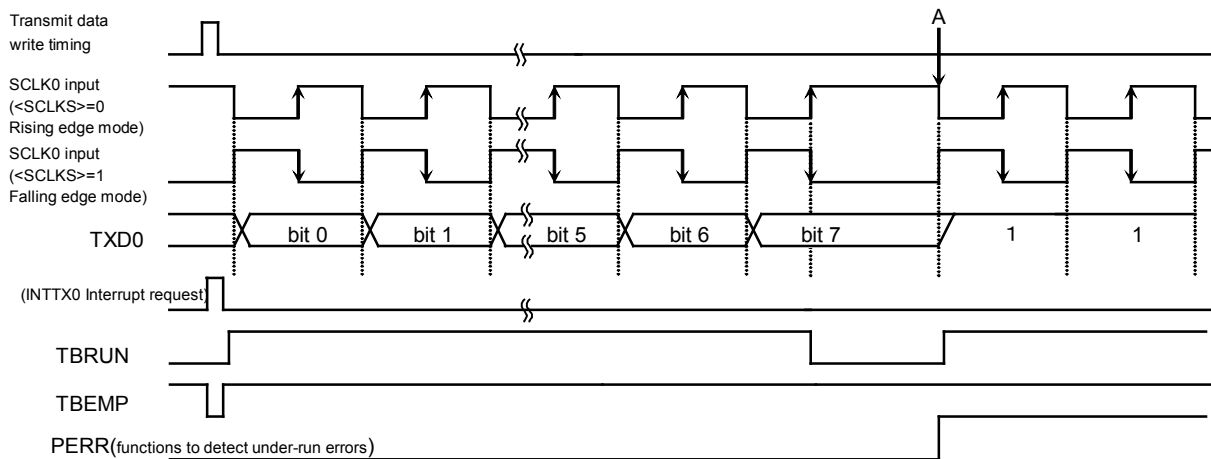

<WBUF>="1" (if double buffering is enabled and there is no data in buffer 2)

Fig. 11-11 Transmit Operation in the I/O Interface Mode (SCLK0 Input Mode)

② Receiving data  
SCLK output mode

In the SCLK output mode, if SC0MOD2 <WBUF> = "0" and receive double buffering is disabled, a synchronous clock pulse is output from the SCLK0 pin and the next data is shifted into receive buffer 1 each time the CPU reads received data. When all the 8 bits are received, the INTRX0 interrupt is generated.

The first SCLK output can be started by setting the receive enable bit SC0MOD0 <RXE> to "1." If the receive double buffering is enabled with SC0MOD2 <WBUF> set to "1," the first frame received is moved to receive buffer 2 and receive buffer 1 can receive the next frame successively. As data is moved from receive buffer 1 to receive buffer 2, the receive buffer full flag SC0MOD2 <RBFULL> is set to "1" and the INTRX0 interrupt is generated.

While data is in receive buffer 2, if CPU/DMAC cannot read data from receive buffer 2 before completing reception of the next 8 bits, the INTRX0 interrupt is not generated and the SCLK0 clock stops. In this state, reading data from receive buffer 2 allows data in receive buffer 1 to move to receive buffer 2 and thus the INTRX0 interrupt is generated and data reception resumes.

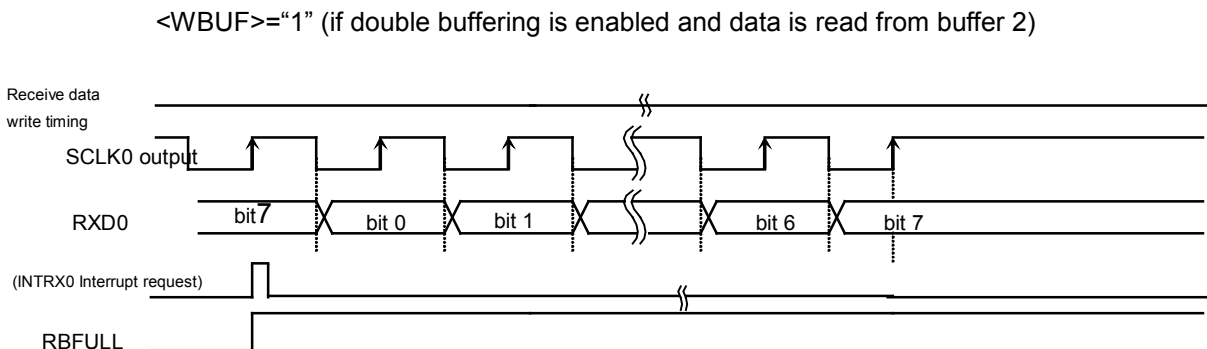
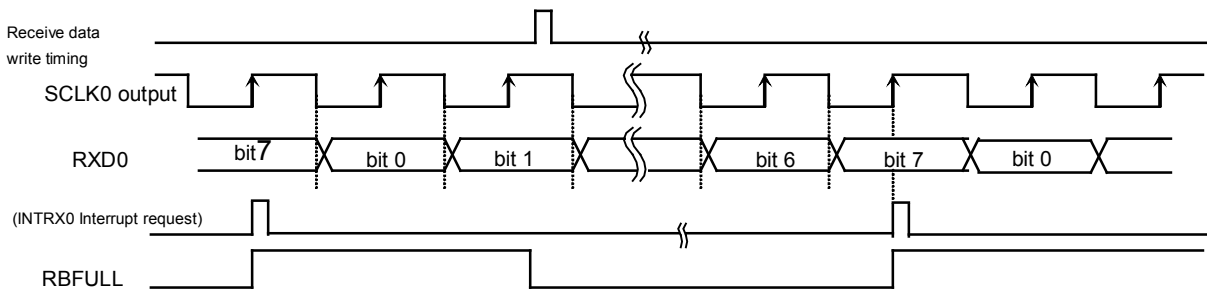
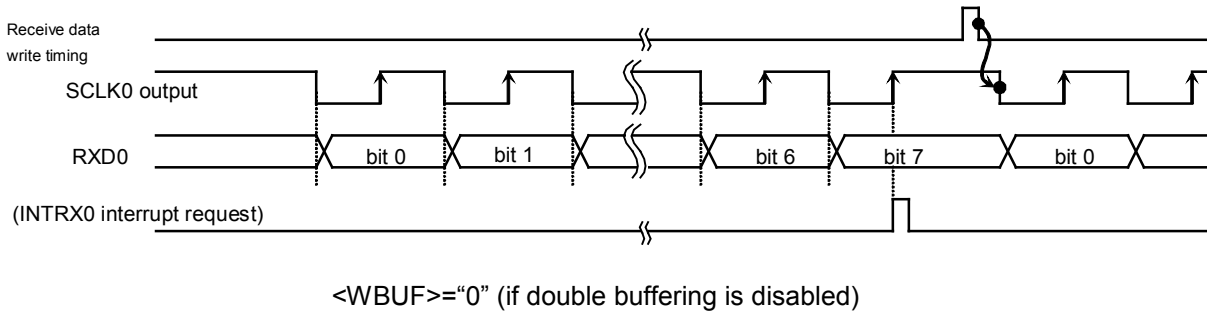

<WBUF>="1" (if double buffering is enabled and data cannot be read from buffer 2)

Fig. 11-12 Receive Operation in the I/O Interface Mode (SCLK0 Output Mode)

SCLK input mode

In the SCLK input mode, receiving double buffering is always enabled, the received frame can be moved to receive buffer 2 and receive buffer 1 can receive the next frame successively.

The INTRX receive interrupt is generated each time received data is moved to received buffer 2.

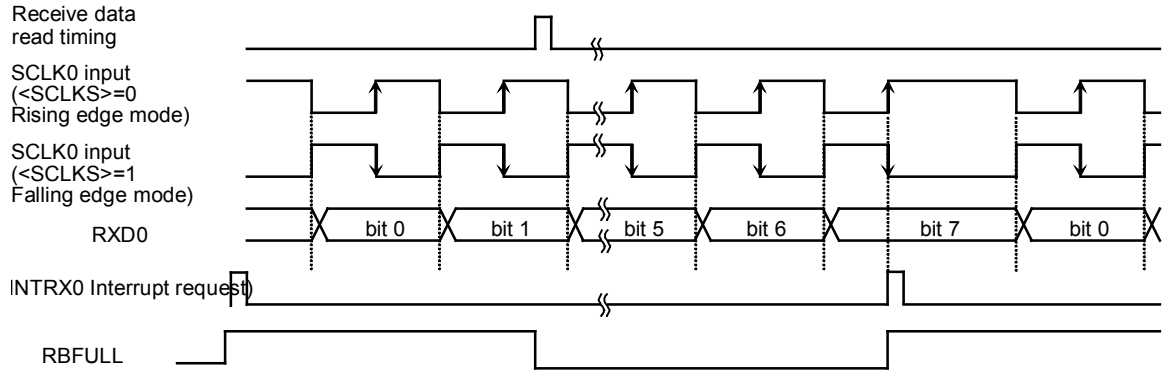

If data is read from buffer 2

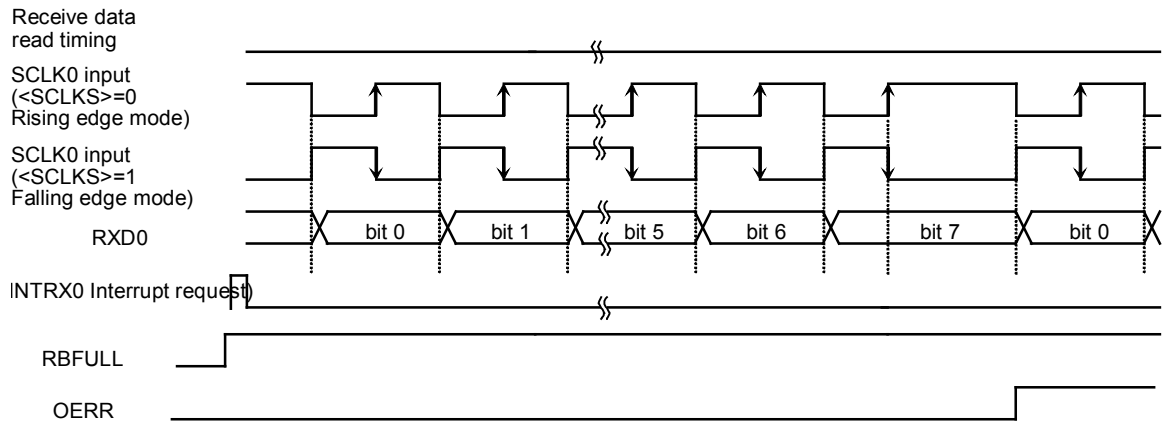

If data cannot be read from buffer 2

Fig. 11-13 Receive Operation in the I/O Interface Mode (SCLK0 Input Mode)

**(Note) To receive data, SC0MOD <RXE> must always be set to "1" (receive enable) in the SCLK output / SCLK input mode.**

③ Transmit and receive (full-duplex)

The full-duplex mode is enabled by setting bit 6 <FDPX0> of the serial mode control register 1 (SC0MOD1) to "1".

SCLK output mode

In the SCLK output mode, if SC0MOD2 <WBUF> is set to "0" and both the transmit and receive double buffers are disabled, SCLK is output when the CPU writes data to the transmit buffer. Subsequently, 8 bits of data are shifted into receive buffer 1 and the INTRX0 receive interrupt is generated. Concurrently, 8 bits of data written to the transmit buffer are output from the TXD0 pin, the INTTX0 transmit interrupt is generated when transmission of all data bits has been completed. Then, the SCLK output stops. In this, the next round of data transmission and reception starts when the data is read from the receive buffer and the next transmit data is written to the transmit buffer by the CPU. The order of reading the receive buffer and writing to the transmit buffer can be freely determined. Data transmission is resumed only when both conditions are satisfied.

If SC0MOD2 <WBUF> = "1" and double buffering is enabled for both transmission and reception, SCLK is output when the CPU writes data to the transmit buffer. Subsequently, 8 bits of data are shifted into receive buffer 1, moved to receive buffer 2, and the INTRX0 interrupt is generated. While 8 bits of data is received, 8 bits of transmit data is output from the TXD0 pin. When all data bits are sent out, the INTTX0 interrupt is generated and the next data is moved from the Transmit Buffer 2 to Transmit Buffer 1. If Transmit Buffer 2 has no data to be moved to Transmit Buffer 1 (SC0MOD2 <TBEMP> = 1) or when receive buffer 2 is full (SC0MOD2 <RBFULL> = 1), the SCLK clock is stopped. When both conditions, receive data is read and transmit data is written, are satisfied, the SCLK output is resumed and the next round of data transmission is started.

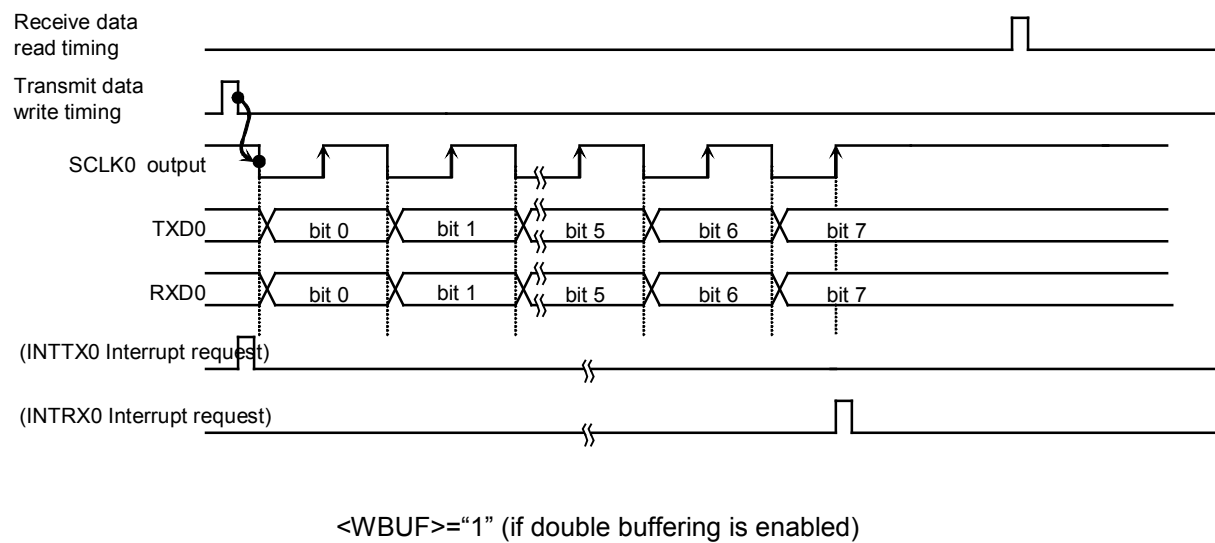
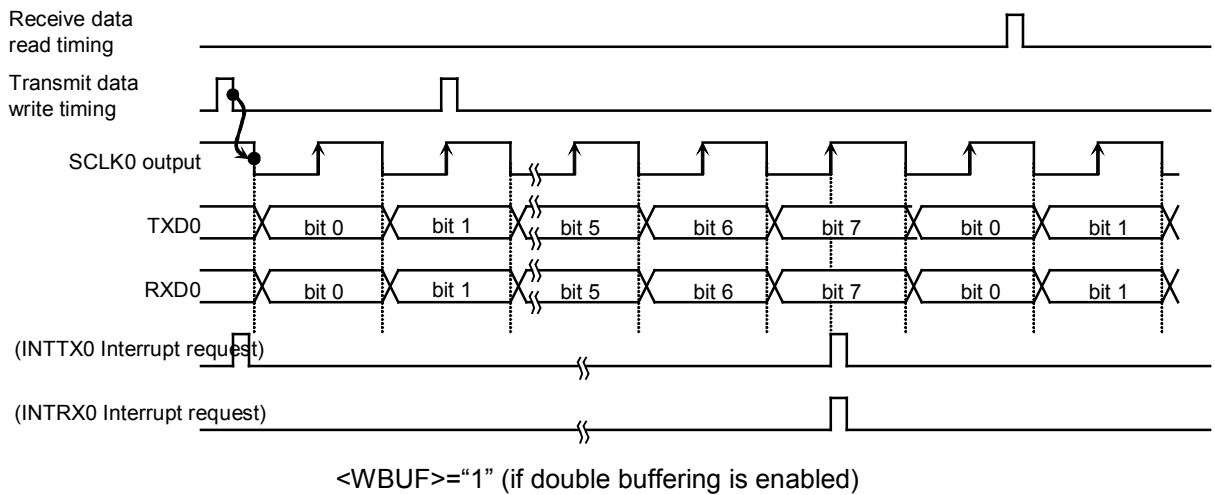
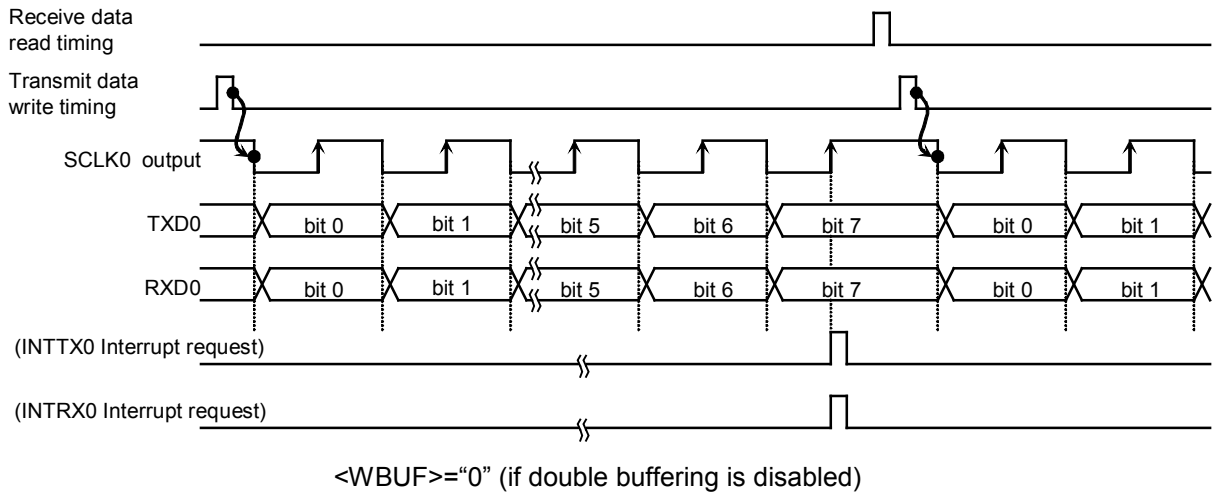
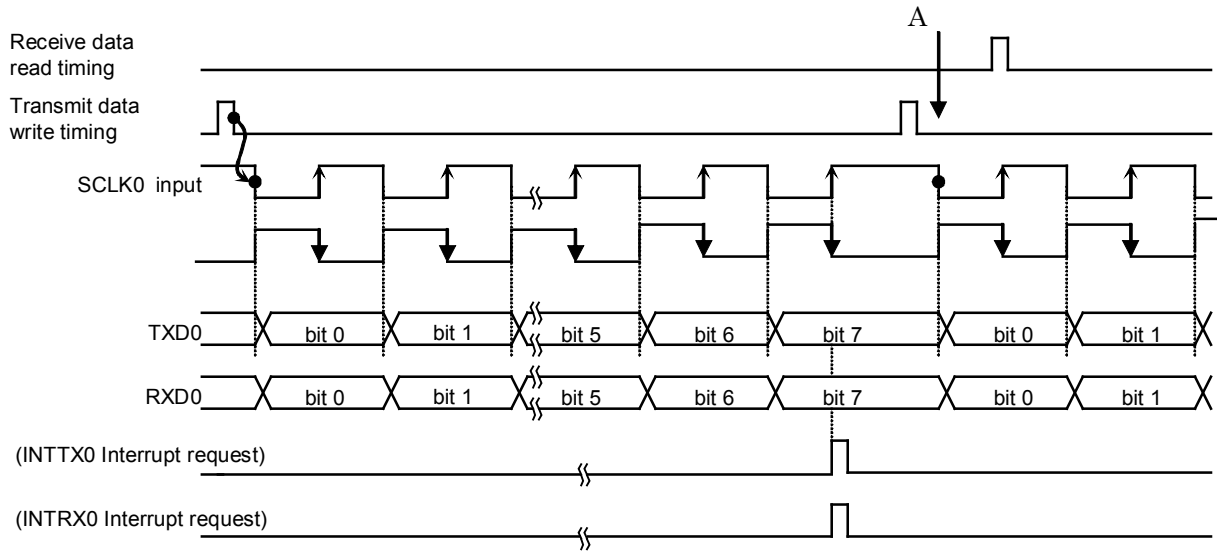

Fig. 11-14 Transmit/Receive Operation in the I/O Interface Mode (SCLK0 Output Mode)

### SCLK input mode

In the SCLK input mode with SC0MOD2 <WBUF> set to “0” and the transmit double buffers are disabled (double buffering is always enabled for the receive side), 8-bit data written in the transmit buffer is output from the TXD0 pin and 8 bits of data is shifted into the receive buffer when the SCLK input becomes active. The INTTX0 interrupt is generated upon completion of data transmission and the INTRX0 interrupt is generated at the instant the received data is moved from receive buffer 1 to receive buffer 2. Note that transmit data must be written into the transmit buffer before the SCLK input for the next frame (data must be written before the point A in Fig. 11-15). As double buffering is enabled for data reception, data must be read before completing reception of the next frame data.

If SC0MOD2 <WBUF> = “1” and double buffering is enabled for both transmission and reception, the interrupt INTRX0 is generated at the timing Transmit Buffer 2 data is moved to Transmit Buffer 1 after completing data transmission from Transmit Buffer 1. At the same time, the 8 bits of data received is shifted to buffer 1, it is moved to receive buffer 2, and the INTRX0 interrupt is generated. Upon the SCLK input for the next frame, transmission from Transmit Buffer 1 (in which data has been moved from Transmit Buffer 2) is started while receive data is shifted into receive buffer 1 simultaneously. If data in receive buffer 2 has not been read when the last bit of the frame is received, an overrun error occurs. Similarly, if there is no data written to Transmit Buffer 2 when SCLK for the next frame is input, an under-run error occurs.



<WBUF>="0" (if double buffering is disabled)

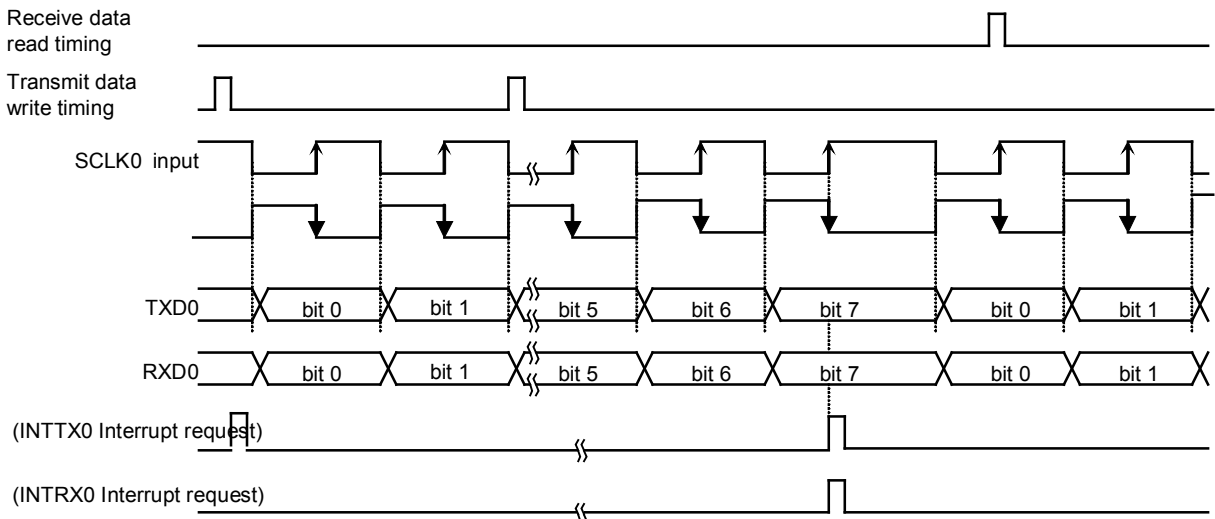

<WBUF>="1" (if double buffering is enabled with no errors)

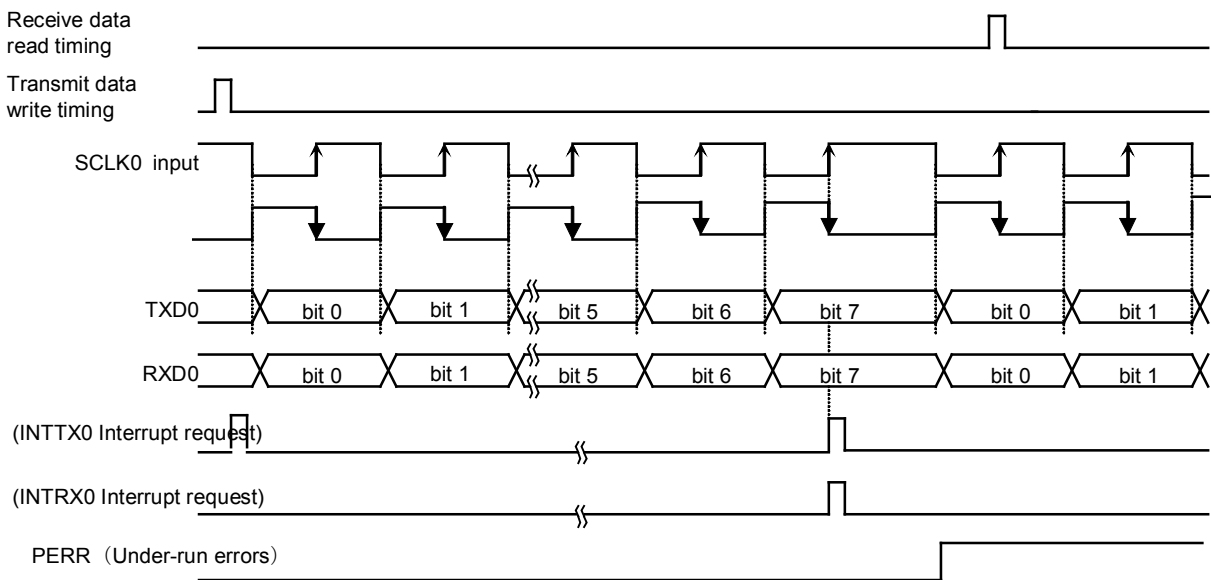

<WBUF>="1" (if double buffering is enabled with error generation)

Fig. 11-15 Transmit/Receive Operation in the I/O Interface Mode (SCLK0 Input Mode)

### 11.5.2 Mode 1 (7-bit UART Mode)

The 7-bit UART mode can be selected by setting the serial mode control register (SCOMOD <SM[1, 0]>) to "01".

In this mode, parity bits can be added to the transmit data stream; the serial mode control register (SCOCR <PE>) controls the parity enable/disable setting. When <PE> is set to "1" (enable), either even or odd parity may be selected using the SCOCR <EVEN> bit. The length of the stop bit can be specified using SCOMOD2<SBLEN>.

The following table shows the control register settings for transmitting in the following data format.

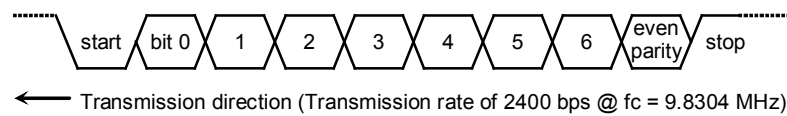

* Clocking conditions	{	System clock : high- speed ( $f_c$ ) High-speed clock gear : x1 ( $f_c$ ) Prescaler clock : $f_{\text{periph}}/2$ ( $f_{\text{periph}} = f_{\text{sys}}$ )
-----------------------	---	--

### 11.5.3 Mode 2 (8-bit UART Mode)

The 8-bit UART mode can be selected by setting SC0MOD0 <SM[1:0]> to "10." In this mode, parity bits can be added and parity enable/disable is controlled using SC0CR <PE>. If <PE> = "1" (enabled), either even or odd parity can be selected using SC0CR <EVEN>.

The control register settings for receiving data in the following format are as follows:

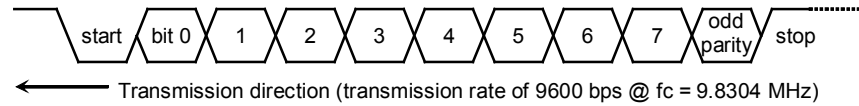

* Clocking conditions	{	System clock	: High-speed ( $f_c$ )
		High-speed clock gear	: x1 ( $f_c$ )
		Prescaler clock	: $f_{\text{periph}}/4$ ( $f_{\text{periph}} = f_{\text{sys}}$ )

### 11.5.4 Mode 3 (9-bit UART)

The 9-bit UART mode can be selected by setting SC0MOD0 <SM[1:0]> to "11." In this mode, parity bits must be disabled (SC0CR <PE> = "0").

The most significant bit (9th bit) is written to bit 7 <TB8> of the serial mode control register 0 (SC0MOD0) for transmitting data. The data is stored in bit 7 <RB8> of the serial control register SC0CR. When writing or reading data to/from the buffers, the most significant bit must be written or read first before writing or reading to/from SC0BUF. The stop bit length can be specified using SC0MOD2 <SBLEN>.

#### Wakeup function

In the 9-bit UART mode, slave controllers can be operated in the wake-up mode by setting the wake-up function control bit SC0MOD0 <WU> to "1." In this case, the interrupt INTRX0 will be generated only when SC0CR <RB8> is set to "1".

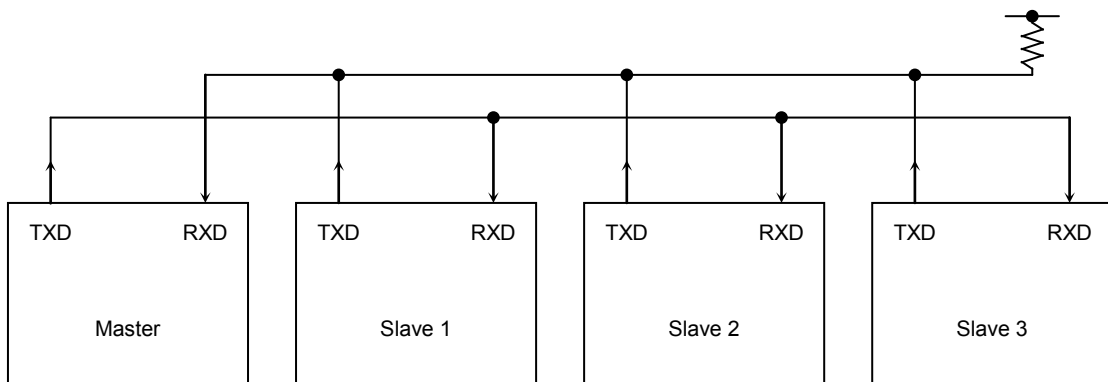

**(Note) The TXD pin of the slave controller must be set to the open drain output mode using the ODE register.**

Fig. 11-16 Serial Links to Use Wake-up Function

Protocol

- ① Select the 9-bit UART mode for the master and slave controllers.
- ② Set SC0MOD <WU> to “1” for the slave controllers to make them ready to receive data.
- ③ The master controller is to transmit a single frame of data that includes the slave controller select code (8 bits). In this, the most significant bit (bit 8) <TB8> must be set to “1”.

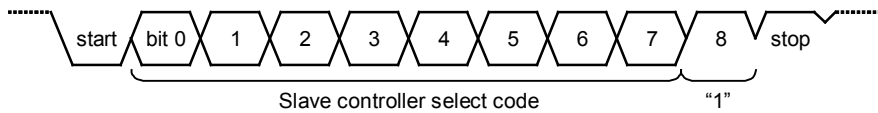

- ④ Each slave controller receives the above data frame; if the code received matches with the controller's own select code, it clears the WU bit to “0”.
- ⑤ The master controller transmits data to the designated slave controller (the controller of which SC0MOD <WU> bit is cleared to “0”). In this, the most significant bit (bit 8) <TB8> must be set to “0”.

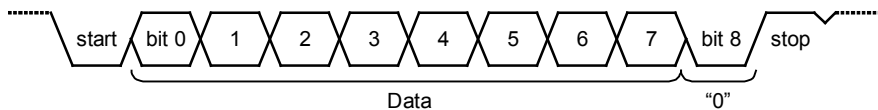

- ⑥ The slave controllers with the <WU> bit set to “1” ignore the receive data because the most significant bit (bit 8) <RB8> is set to “0” and thus no interrupt (INTRX0) is generated. Also, the slave controller with the <WU> bit set to “0” can transmit data to the master controller to inform that the data has been successfully received.

An example: Using the internal clock  $f_{SYS}$  as the transfer clock, two slave controllers are serially linked as follows.

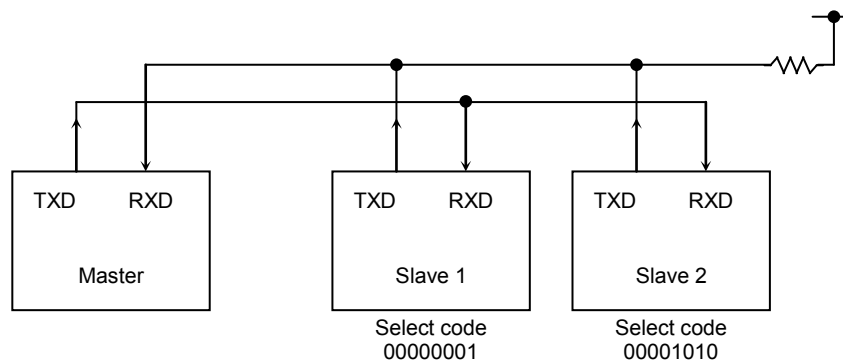

## 12 Serial Bus Interface (SBI)

The TMPM330 contains three Serial Bus Interface (SBI) channels, in which the following two operating modes are included:

- I<sup>2</sup>C bus mode (with multi-master capability)
- Clock-synchronous 8-bit SIO mode

In the I<sup>2</sup>C bus mode, the SBI is connected to external devices via SCL and SDA. In the clock-synchronous 8-bit SIO mode, the SBI is connected to external devices via SCK, SI and SO.

The following table shows the programming required to put the SBI in each operating mode.

		Pin name (PIN No.)	Port Function Register	Port Control Register	Port Input Register	Port Open Drain Output
Channel 0	I <sup>2</sup> C bus mode	SCL : PG1 (27) SDA : PG0 (26)	PGFR1[1:0] = 11	PGCR[1:0] = 11	PGIE[1:0] = 11	PGOD[1:0] = 11
	Clock-synchronous 8-bit SIO mode	SCK : PG2 (28) SI : PG1 (27) SO : PG0 (26)	PGFR1[2:0] = 111	PGCR[2:0] = 101	PGIE[2:0] = 110	PGOD[2:0] = xxx
Channel 1	I <sup>2</sup> C bus mode	SCL : PF5 (45) SDA : PF4 (44)	PFFR1[5:4] = 11	PFCR[5:4] = 11	PFIE[5:4] = 11	PFOD[5:4] = 11
	Clock-synchronous 8-bit SIO mode	SCK : PF6 (46) SI : PF5 (45) SO : PF4 (44)	PFFR1[6:4] = 111	PFCR[6:4] = 101	PFIE[6:4] = 110	PFOD[6:4] = xxx
Channel 2	I <sup>2</sup> C bus mode	SCL : PG5 (16) SDA : PG4 (15)	PGFR1[5:4] = 11	PGCR[5:4] = 11	PGIE[5:4] = 11	PGOD[5:4] = 11
	Clock-synchronous 8-bit SIO mode	SCK : PG6 (17) SI : PG5 (16) SO : PG4 (15)	PGFR1[6:4] = 111	PGCR[6:4] = 101	PGIE[6:4] = 110	PGOD[6:4] = xxx

X: Don't care

### 12.1 Configuration

The configuration is shown in Fig. 12-1.

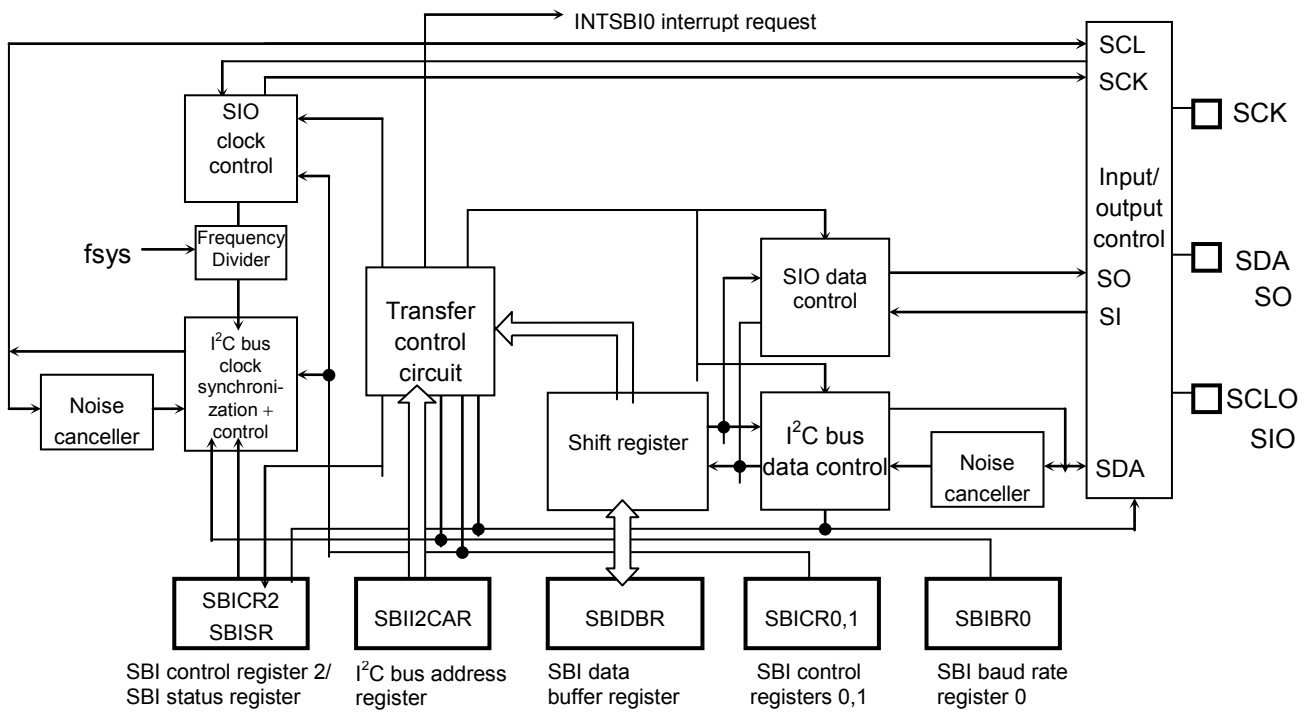

Fig. 12-1 SBI Block Diagram

## 12.2 Control

The following registers control the serial bus interface and provide its status information for monitoring.

- Serial bus interface control registers 0 (SBIxCR0)
- Serial bus interface control registers 1 (SBIxCR1)
- Serial bus interface control registers 2 (SBIxCR2)
- Serial bus interface buffer registers (SBIxDBR)
- I<sup>2</sup>C bus address register (SBIxI2CAR)
- Serial bus interface status registers (SBIxSR)
- Serial bus interface baud rate registers 0 (SBIxBR0)

The functions of these registers vary, depending on the mode in which the SBI is operating. For a detailed description of the registers, refer to “12.5 Control in the I2C Bus Mode” and “12.7 Control in the Clock-synchronous 8-bit SIO Mode”.

The addresses of each register are shown below.

		Channel 0	Channel 1	Channel 2
Register name (address)	Serial bus interface control register 0	SBI0CR0 0x4002_0000	SBI1CR0 0x4002_0020	SBI2CR0 0x4002_0040
	Serial bus interface control register 1	SBI0CR1 0x4002_0004	SBI1CR1 0x4002_0024	SBI2CR1 0x4002_0044
	Serial bus interface control register 2	SBI0CR2 (reading) 0x4002_0010	SBI1CR2 (reading) 0x4002_0030	SBI2CR2 (reading) 0x4002_0050
	Serial bus interface status register	SBI0SR (writing)	SBI1SR (writing)	SBI2SR (writing)
	Serial bus interface baud rate register 0	SBI0BR0 0x4002_0014	SBI1BR0 0x4002_0034	SBI2BR0 0x4002_0054
	Serial bus interface data buffer register	SBI0DBR 0x4002_0008	SBI1DBR 0x4002_0028	SBI2DBR 0x4002_0048
	I <sup>2</sup> C bus address register	SBI0I2CAR 0x4002_000C	SBI1I2CAR 0x4002_002C	SBI2I2CAR 0x4002_004C

### 12.3 I<sup>2</sup>C Bus Mode Data Formats

Fig. 12-2 shows the data formats used in the I<sup>2</sup>C bus mode.

(a) Addressing format

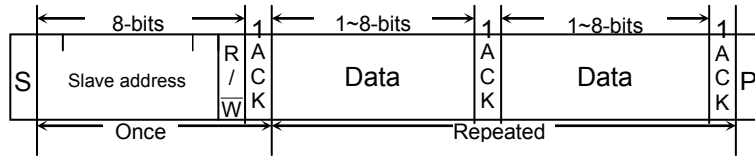

(b) Addressing format (with repeated start condition)

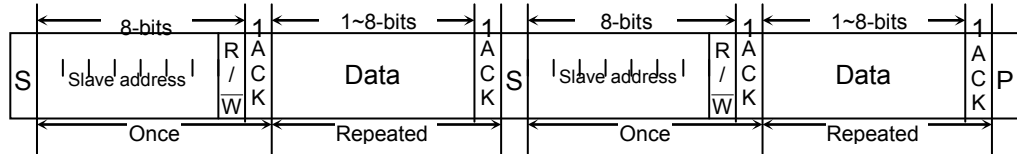

(c) Free data format (master-transmitter to slave-receiver)

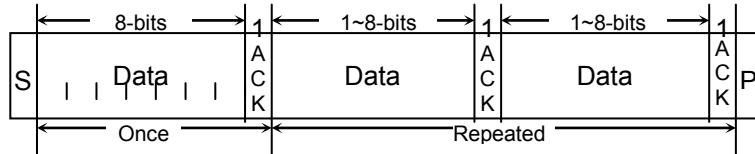

Note) S: Start condition  
 R/ $\bar{W}$ : Direction bit  
 ACK: Acknowledge bit  
 P: Stop condition

Fig. 12-2 I<sup>2</sup>C Bus Mode Data Formats

### 12.4 Control Registers in the I2C Bus Mode

The following registers control the serial bus interface (SBI) in the I<sup>2</sup>C bus mode and provide its status information for monitoring.

		Serial bus control register 0							
		7	6	5	4	3	2	1	0
SBIxCR0	bit Symbol	SBIEN							
	Read/Write	R/W							
	After reset	0							
	Function	SBI operation 0: Disable 1: Enable							
		This can be read as "0."							
		15	14	13	12	11	10	9	8
bit Symbol									
Read/Write		R							
After reset		0							
Function		This can be read as "0."							
		23	22	21	20	19	18	17	16
bit Symbol									
Read/Write		R							
After reset		0							
Function		This can be read as "0."							
		31	30	29	28	27	26	25	24
bit Symbol									
Read/Write		R							
After reset		0							
Function		This can be read as "0."							

<SBIEN>: To use the SBI, enable the SBI operation ("1") before setting each register in the SBI module.

**Fig. 12-3 I<sup>2</sup>C Bus Mode register**

SBixCR1

Serial bus control register 1

	7	6	5	4	3	2	1	0
Bit symbol	BC2	BC1	BC0	ACK		SCK2	SCK1	SCK0/ SWRMON
Read/Write	R/W			R/W	R	R/W		R/W
After reset	0	0	0	0	1	0	0	1
Function	Select the number of bits per transfer (Note 1)			Acknowledgment clock 0: Not generate 1: Generate	This can be read as "1."	Select internal SCL output clock frequency (Note 2) and reset monitor.		
	15	14	13	12	11	10	9	8
Bit symbol								
Read/Write	R							
After reset	0							
Function	This can be read as "0."							
	23	22	21	20	19	18	17	16
Bit symbol								
Read/Write	R							
After reset	0							
Function	This can be read as "0."							
	31	30	29	28	27	26	25	24
Bit symbol								
Read/Write	R							
After reset	0							
Function	This can be read as "0."							

<Bit 2:0><SCK[2:0]>: Select internal SCL output clock frequency

On writing <SCK[2:0]>: Select internal SCL output clock frequency

000	n=5	196 kHz	System clock: fsys (=40 MHz) Clock gear : fc/1 Frequency = $\frac{fsys}{2^n + 72}$ [ Hz ]
001	n=6	149 kHz	
010	n=7	101 kHz	
011	n=8	61 kHz	
100	n=9	34 kHz	
101	n=10	18 kHz	
110	n=11	9 kHz	
111		reserved	

<Bit 0>< SWRMON :0>: Software reset status monitor

On reading <SWRMON>: Software reset status monitor

0	Software reset operation is in progress.
1	Software reset operation is not in progress.

<Bit 7:5><BC[2:0]> : Select the number of bits per transfer

Select the number of bits per transfer

<BC[2:0]>	When <ACK> = 0		When <ACK> = 1	
	Number of clock cycles	Data length	Number of clock cycles	Data length
000	8	8	9	8
001	1	1	2	1
010	2	2	3	2
011	3	3	4	3
100	4	4	5	4
101	5	5	6	5
110	6	6	7	6
111	7	7	8	7

Fig. 12-4 I<sup>2</sup>C Bus Mode register

- (Note 1) Clear <BC[2:0]> to "000" before switching the operation mode to the clock-synchronous 8-bit SIO mode.
- (Note 2) For details on the SCL line clock frequency, refer to "12.5.3 Serial Clock."
- (Note 3) After a reset, the <SCK0/SWRMON> bit is read as "1." However, if the SIO mode is selected at the SB<sub>l</sub>xCR2 register, the initial value of the <SCK0> bit is "0."
- (Note 4) The initial value for selecting a frequency is <SCK[2:0]>=000 and is independent of read initial value.
- (Note 5) When <BC[2:0]>="001" and <ACK>="0" in master mode, SCL line may be fixed to "L" by falling edge of SCL line after generation of STOP condition and the other master devices can not use the bus. In the case of bus which is connected with several master devices, the number of bits per transfer should be set equal or more than 2 before generation of STOP condition.

Serial bus control register 2

SBIXCR2	bit Symbol	7	6	5	4	3	2	1	0
	Read/Write	W				W (Note 2)		W (Note 1)	
	After reset	0	0	0	1	0	0	0	0
	Function	Select master/slave 0: Slave 1: Master	Select transmit/receive 0: Receive 1: Transmit	Start/stop condition generation 0: Stop condition generated 1: Start condition generated	Clear INTSBI <sub>n</sub> interrupt request 0: – 1: Clear interrupt request	Select serial bus interface operating mode (Note 2) 00: Port mode 01: SIO mode 10: I <sup>2</sup> C bus mode 11: (Reserved))		Software reset generation Write “10” followed by “01” to generate a reset.	
	15	14	13	12	11	10	9	8	
	bit Symbol								
	Read/Write R								
	After reset 0								
	Function This can be read as “0.”								
	23	22	21	20	19	18	17	16	
	bit Symbol								
	Read/Write R								
	After reset 0								
	Function This can be read as “0.”								
	31	30	29	28	27	26	25	24	
	bit Symbol								
	Read/Write R								
	After reset 0								
	Function This can be read as “0.”								

<Bit 1:0><SWRST[1:0]>: Write “10” followed by “01” to generate a reset.  
 <Bit 3:2><SBIM[1:0]> : Select serial bus interface operating mode

Select serial bus interface operating mode (Note 2)

00	Port mode (disables serial bus interface output)
01	Clock –synchronous 8-bit SIO mode
10	I <sup>2</sup> C bus mode
11	(Reserved)

<Bit 4><PIN> : Clear INTSBI<sub>n</sub> interrupt request  
 <Bit 5><BB> : Start/stop condition generation  
 <Bit 6><TRX> : Select transmit/ receive  
 <Bit 7><MST> : Select master/slave

- (Note 1) Reading this register causes it to function as the SBInSR register.
- (Note 2) Ensure that the bus is free before switching the operating mode to the port mode. Ensure that the port is at the “H” level before switching the operating mode from the port mode to the I<sup>2</sup>C bus or clock-synchronous 8-bit SIO mode.
- (Note 3) Ensure that serial transfer is completed before switching the mode.

Fig. 12-5 I<sup>2</sup>C Bus Mode register

**Table 12-1 Base Clock Resolution**

@fsys = 40 MHz

Clock gear value <GEAR[1:0]>	Base clock resolution
00 (fc)	$f_{sys}/2^2$ (0.1 $\mu$ s)
01 (fc/2)	$f_{sys}/2^3$ (0.2 $\mu$ s)
10 (fc/4)	$f_{sys}/2^4$ (0.4 $\mu$ s)
11 (fc/8)	$f_{sys}/2^5$ (0.8 $\mu$ s)

Serial bus interface status register

SBIxSR	bit Symbol	7	6	5	4	3	2	1	0
	Read/Write	R							
	After reset	0	0	0	1	0	0	0	0
	Function	Master/ slave selection monitor 0: Slave 1: Master	Transmit/ receive selection monitor 0: Receive 1: Transmit	I <sup>2</sup> C bus state monitor 0: Free 1: Busy	INTSBIIn interrupt request monitor 0: Interrupt request generated 1: Interrupt request cleared	Arbitration lost detection 0: – 1: Detected	Slave address match detection 0: – 1: Detected	General call detection 0: – 1: Detected	Last received bit monitor 0: "0" 1: "1"
	bit Symbol	15	14	13	12	11	10	9	8
	Read/Write	R							
	After reset	0							
	Function	This can be read as "0."							
	bit Symbol	23	22	21	20	19	18	17	16
	Read/Write	R							
After reset	0								
Function	This can be read as "0."								
bit Symbol	31	30	29	28	27	26	25	24	
Read/Write	R								
After reset	0								
Function	This can be read as "0."								

**(Note) Writing to this register causes it to function as SBI0CR2.**

Fig. 12-6 I<sup>2</sup>C Bus Mode register

- <Bit 0><LRB> : Last received bit monitor
- <Bit 1><ADO> : General call detection
- <Bit 2><AAS> : Slave address match detection  
(This bit is set when the general call is detected as well.)
- <Bit 3><AL> : Arbitration lost detection
- <Bit 4><PIN> : INTSBIIn interrupt request monitor
- <Bit 5><BB> : I<sup>2</sup>C bus state monitor
- <Bit 6><TRX> : Transmit/ receive selection monitor
- <Bit 7><MST> : Master/ slave selection monitor

Serial bus interface baud rate register 0

SBIxBR0

	7	6	5	4	3	2	1	0	
bit Symbol		I2SBI							
Read/Write	R	R/W	R						R/W
After reset	1	0	1						0
Function	This can be read as "1".	IDLE 0: Stop 1: Operate	This can be read as "1".						Be sure to write "0".
	15	14	13	12	11	10	9	8	
bit Symbol									
Read/Write	R								
After reset	0								
Function	This can be read as "0".								
	23	22	21	20	19	18	17	16	
bit Symbol									
Read/Write	R								
After reset	0								
Function	This can be read as "0".								
	31	30	29	28	27	26	25	24	
bit Symbol									
Read/Write	R								
After reset	0								
Function	This can be read as "0".								

<Bit 6><I2SBI0> : Operation at the IDLE mode

Serial bus interface data buffer register

SB1xDBR		7	6	5	4	3	2	1	0
	bit Symbol	DB7	DB6	DB5	DB4	DB3	DB2	DB1	DB0
	Read/Write	R (Receive)/W (Transmit)							
	After reset	0							
	Function	RX data/ TX data.							
		15	14	13	12	11	10	9	8
	bit Symbol								
	Read/Write	R							
	After reset	0							
	Function	This can be read as "0".							
		23	22	21	20	19	18	17	16
	bit Symbol								
	Read/Write	R							
	After reset	0							
	Function	This can be read as "0".							
		31	30	29	28	27	26	25	24
bit Symbol									
Read/Write	R								
After reset	0								
Function	This can be read as "0".								

- (Note 1)** The transmission data must be written in to the register from the MSB (bit 7). The received data is stored in the LSB.
- (Note 2)** Since SB1xI2CAR has independent buffers for writing and reading, a written data cannot be read. Thus, read-modify-write instructions, such as bit manipulation, cannot be used.

I<sup>2</sup>C bus address register

SBIxI2CAR		7	6	5	4	3	2	1	0	
	bit Symbol	SA6	SA5	SA4	SA3	SA2	SA1	SA0	ALS	
	Read/Write	R/W								
	After reset	0	0	0	0	0	0	0	0	
	Function	Set the slave address when the SBI acts as a slave device.							Specify address recognition mode	
		15	14	13	12	11	10	9	8	
	bit Symbol									
	Read/Write	R								
	After reset	0								
	Function	This can be read as "0".								
	23	22	21	20	19	18	17	16		
bit Symbol										
Read/Write	R									
After reset	0									
Function	This can be read as "0".									
	31	30	29	28	27	26	25	24		
bit Symbol										
Read/Write	R									
After reset	0									
Function	This can be read as "0".									

<Bit 0><ALS> : Specify address recognition mode

- (Note 1)** Please set the bit 0 <ALS> of I<sup>2</sup>C bus address register SBIxI2CAR to "0", except when you use a free data format. It operates as a free data format when setting it to "1". Selecting the master fixes to transmission. Selecting the slave fixes to reception.
- (Note 2)** Do not set SBIxI2CAR to "0x00" in slave mode. (If SBIxI2CAR is set to "0x00", it's recognized that the slave address matches the START byte ("0x01") of the I<sup>2</sup>C standard received in slave mode.)

Fig. 12-7 I<sup>2</sup>C Bus Mode Register

## 12.5 Control in the I2C Bus Mode

### 12.5.1 Setting the Acknowledgement Mode

Setting SBIxCR1<ACK> to “1” selects the acknowledge mode. When operating as a master, the SBI adds one clock for acknowledgment signals. As a transmitter, the SBI releases the SDA pin during this clock cycle to receive acknowledgment signals from the receiver. As a receiver, the SBI pulls the SDA pin to the “L” level during this clock cycle and generates acknowledgment signals.

By setting <ACK> to “0”, the non-acknowledgment mode is activated. When operating as a master, the SBI does not generate clock for acknowledgment signals.

### 12.5.2 Setting the Number of Bits per Transfer

SBIxCR1 <BC[2:0]> specifies the number of bits of the next data to be transmitted or received.

Under the start condition, <BC[2:0]> is set to “000,” causing a slave address and the direction bit to be transferred in a packet of eight bits. At other times, <BC[2:0]> keeps a previously programmed value.

### 12.5.3 Serial Clock

① Clock source

SBIxCR1 <SCK[2:0]> specifies the maximum frequency of the serial clock to be output from the SCL pin in the master mode.

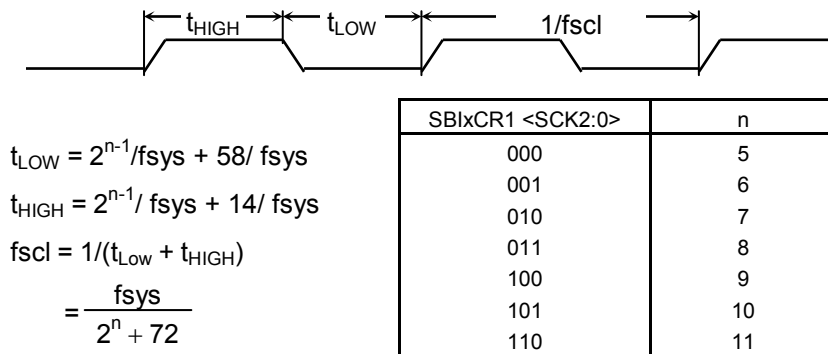

Fig. 12-8 Clock Source

**(Note)** The highest speeds in the standard and high-speed modes are specified to 100KHz and 400KHz respectively following the communications standards. Note that the internal SCL clock frequency is determined by the fsys used and the calculation formula shown above.

### ② Clock Synchronization

The I<sup>2</sup>C bus is driven by using the wired-AND connection due to its pin structure. The first master that pulls its clock line to the “L” level overrides other masters producing the “H” level on their clock lines. This must be detected and responded by the masters producing the “H” level.

Clock synchronization assures correct data transfer on a bus that has two or more master.

For example, the clock synchronization procedure for a bus with two masters is shown below.

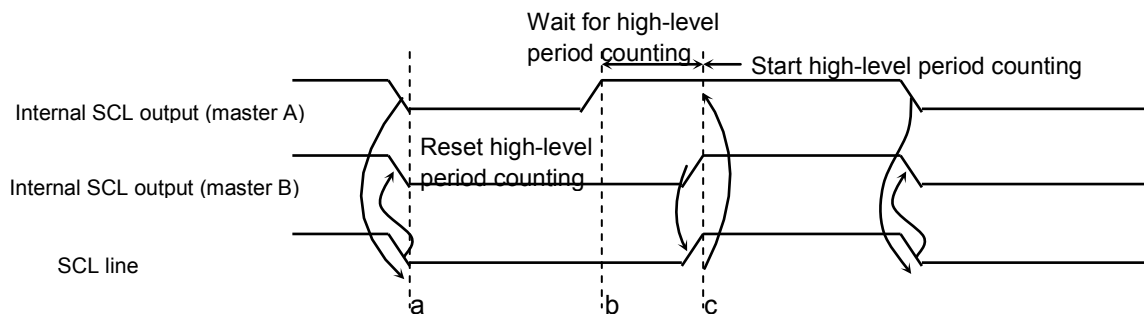

**Fig. 12-9 Example of Clock Synchronization**

At the point a, Master A pulls its internal SCL output to the “L” level, bringing the SCL bus line to the “L” level. Master B detects this transition, resets its “H” level period counter, and pulls its internal SCL output level to the “L” level.

Master A completes counting of its “L” level period at the point b, and brings its internal SCL output to the “H” level. However, Master B still keeps the SCL bus line at the “L” level, and Master A stops counting of its “H” level period counting. After Master A detects that Master B brings its internal SCL output to the “H” level and brings the SCL bus line to the “H” level at the point c, it starts counting of its “H” level period.

This way, the clock on the bus is determined by the master with the shortest “H” level period and the master with the longest “L” level period among those connected to the bus.

#### 12.5.4 Slave Addressing and Address Recognition Mode

When the SBI is configured to operate as a slave device, the slave address <SA[6:0]> and <ALS> must be set at SBIxI2CAR. Setting <ALS> to “0” selects the address recognition mode.

#### 12.5.5 Configuring the SBI as a Master or a Slave

Setting SBIxCR2<MST> to “1” configures the SBI to operate as a master device.

Setting <MST> to “0” configures the SBI as a slave device. <MST> is cleared to “0” by the hardware when it detects the stop condition on the bus or the arbitration lost.

### 12.5.6 Configuring the SBI as a Transmitter or a Receiver

Setting SBIxCR2 <TRX> to “1” configures the SBI as a transmitter. Setting <TRX> to “0” configures the SBI as a receiver.

At the slave mode, the SBI receives the direction bit ( $\overline{R/W}$ ) from the master device on the following occasions:

- when data is transmitted in the addressing format
- when the received slave address matches the value specified at I2CCR
- when a general-call address is received; i.e., the eight bits following the start condition are all zeros

If the value of the direction bit ( $\overline{R/W}$ ) is “1,” <TRX> is set to “1” by the hardware. If the bit is “0,” <TRX> is set to “0”.

As a master device, the SBI receives acknowledgement from a slave device. If the direction bit of “1” is transmitted, <TRX> is set to “0” by the hardware. If the direction bit is “0,” <TRX> changes to “1.” If the SBI does not receive acknowledgement, <TRX> retains the previous value.

<TRX> is cleared to “0” by the hardware when it detects the stop condition on the bus or the arbitration lost.

### 12.5.7 Generating Start and Stop Conditions

When SBIxSR<BB> is “0,” writing “1” to SBIxCR2 <MST, TRX, BB, PIN> causes the SBI to generate the start condition on the bus and output 8-bit data. <ACK> must be set to “1” in advance.

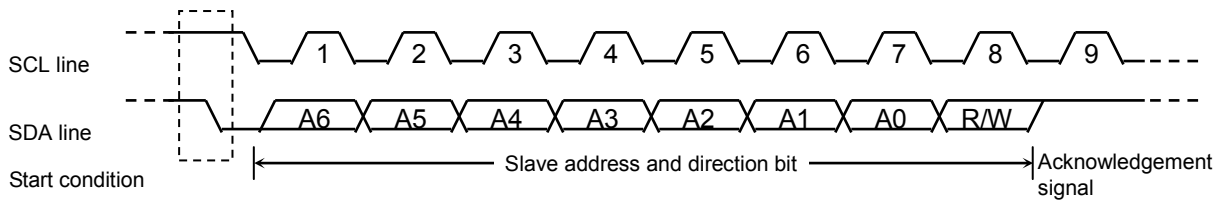

**Fig. 12-10 Generating the Start Condition and a Slave Address**

When <BB> is “1,” writing “1” to <MST, TRX, PIN> and “0” to <BB> causes the SBI to start a sequence for generating the stop condition on the bus. The contents of <MST, TRX, BB, PIN> should not be altered until the stop condition appears on the bus.

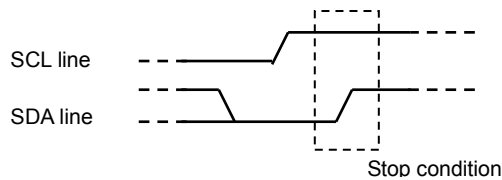

**Fig. 12-11 Generating the Stop Condition**

SBIxSR<BB> can be read to check the bus state. <BB> is set to “1” when the start condition is detected on the bus (the bus is busy), and set to “0” when the stop condition is detected (the bus is free).

### 12.5.8 Interrupt Service Request and Release

In master mode, a serial bus interface request (INTSB<sub>I</sub>x) is generated when the transfer of the number of clock cycles set by <BC> and <ACK> is completed.

In slave mode, INTSB<sub>I</sub>x is generated under the following conditions.

- After output of the acknowledge signal which is generated when the received slave address matches the slave address set to SB<sub>I</sub>xI2CAR<SA[6:0]>.
- After the acknowledge signal is generated when a general-call address is received.
- When the slave address matches or a data transfer is completed after receiving a general-call address.

In the address recognition mode (<ALS> = "0"), INTSB<sub>I</sub>x is generated when the received slave address matches the values specified at SB<sub>I</sub>xI2CAR or when a general-call (eight bits data following the start condition is all "0") is received.

When an interrupt request (INTSB<sub>I</sub>x) is generated, SB<sub>I</sub>xCR2<PIN> is cleared to "0". While <PIN> is cleared to "0", the SBI pulls the SCL line to the "Low" level.

<PIN> is set to "1" when data is written to or read from SB<sub>I</sub>xDBR. It takes a period of t<sub>LOW</sub> for the SCL line to be released after <PIN> is set to "1". When the program writes "1" to <PIN>, it is set to "1". However, writing "0" does not clear this bit to "0".

Note: When arbitration is lost in master mode, <PIN> is not cleared to "0" if the slave address does not match (INTSB<sub>I</sub>x is generated).

### 12.5.9 Serial Bus Interface Operating Modes

SB<sub>I</sub>xCR2 <SBIM1:0> selects an operating mode of the serial bus interface. <SBIM1:0> must be set to "10" to configure the SBI for the I<sup>2</sup>C bus mode. Make sure that the bus is free before switching the operating mode to the port mode.

### 12.5.10 Lost-arbitration Detection Monitor

The I<sup>2</sup>C bus has the multi-master capability (there are two or more masters on a bus), and requires the bus arbitration procedure to ensure correct data transfer.

A master that attempts to generate the start condition while the bus is busy loses bus arbitration, with no start condition occurring on the SDA and SCL lines. The I<sup>2</sup>C-bus arbitration takes place on the SDA line.

The arbitration procedure for two masters on a bus is shown below. Up until the point a, Master A and Master B output the same data. At the point a, Master A outputs the "L" level and Master B outputs the "H" level. Then Master A pulls the SDA bus line to the "L" level because the line has the wired-AND connection. When the SCL line goes high at the point b, the slave device reads the SDA line data, i.e., data transmitted by Master A. At this time, data transmitted by Master B becomes invalid. This condition of Master B is called "Lost Arbitration". Master B releases its SDA pin, so that it does not affect the data transfer initiated by another master. If two or more masters have transmitted exactly the same first data word, the arbitration procedure continues with the second data word.

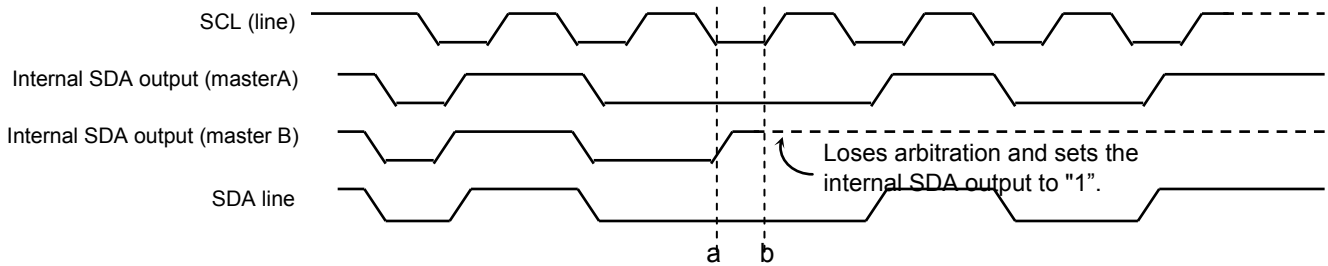

Fig. 12-12 Lost Arbitration

A master compares the SDA bus line level and the internal SDA output level at the rising of the SCL line. If there is a difference between these two values, Arbitration Lost occurs and SBIXSR <AL> is set to "1".

When <AL> is set to "1," SBIXSR <MST, TRX> are cleared to "0," causing the SBI to operate as a slave receiver. <AL> is cleared to "0" when data is written to or read from SBIXDBR or data is written to SBIXCR2.

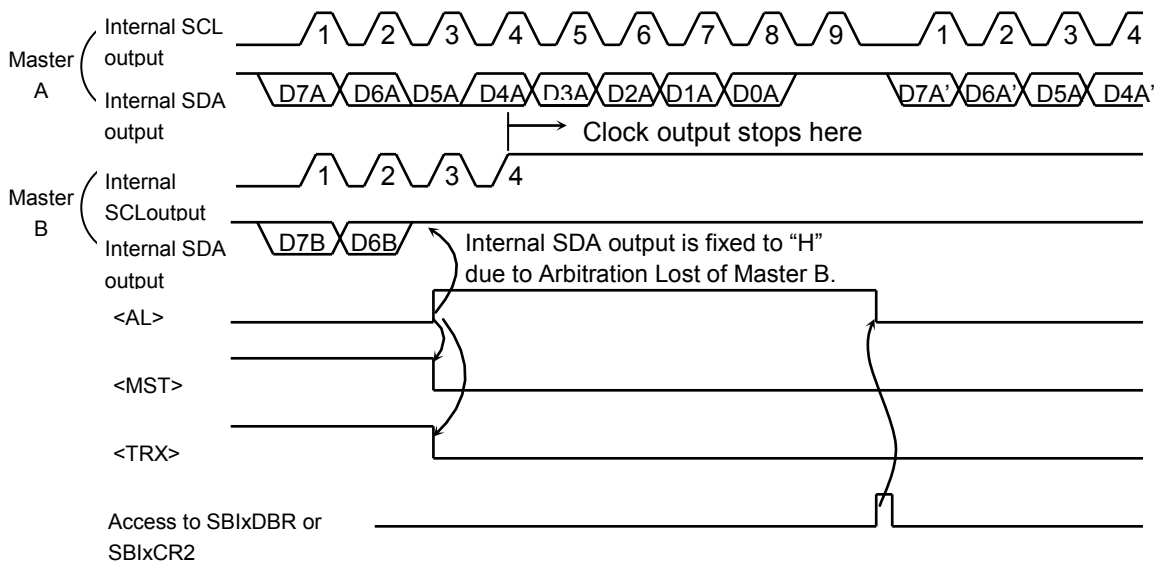

Fig. 12-13 Example of Master B Lost Arbitration (D7A = D7B, D6A = D6B)

12.5.11 Slave Address Match Detection Monitor

When the SBI operates as a slave device in the address recognition mode (SBIX2CAR <ALS> = "0"), SBIXSR <AAS> is set to "1" on receiving the general-call address or the slave address that matches the value specified at SBIX2CAR. When <ALS> is "1," <AAS> is set to "1" when the first data word has been received. <AAS> is cleared to "0" when data is written to or read from SBIXDBR.

### 12.5.12 General-call Detection Monitor

When the SBI operates as a slave device, SBIXSR <AD0> is set to “1” when it receives the general-call address; i.e., the eight bits following the start condition are all zeros. <AD0> is cleared to “0” when the start or stop condition is detected on the bus.

### 12.5.13 Last Received Bit Monitor

SBIXSR <LRB> is set to the SDA line value that was read at the rising of the SCL line. In the acknowledgment mode, reading SBIXSR <LRB> immediately after generation of the INTSBIX interrupt request causes ACK signal to be read.

### 12.5.14 Software Reset

If the serial bus interface circuit locks up due to external noise, it can be initialized by using a software reset.

Writing “10” followed by “01” to SBIXCR2 <SWRST[1:0]> generates a reset signal that initializes the serial bus interface circuit. After a reset, all control registers and status flags are initialized to their reset values. When the serial bus interface is initialized, <SWRST> is automatically cleared to “0”.

<b>(Note)</b>	<b>A software reset causes the SBI operating mode to switch from the I<sup>2</sup>C mode to the port mode.</b>
---------------	--

### 12.5.15 Serial Bus Interface Data Buffer Register (SBIXDBR)

Reading or writing SBIXDBR initiates reading received data or writing transmitted data. When the SBI is acting as a master, setting a slave address and a direction bit to this register generates the start condition.

### 12.5.16 I2C Bus Address Register (SBIXI2CAR)

When the SBI is configured as a slave device, the SBIXI2CAR<SA[6:0]> bit is used to specify a slave address. If I2CAR <ALS> is set to “0,” the SBI recognizes a slave address transmitted by the master device and receives data in the addressing format. If <ALS> is set to “1,” the SBI does not recognize a slave address and receives data in the free data format.

### 12.5.17 IDLE Setting Register (SBIXBR0)

The SBIXBR0<I2SBI> register determines if the SBI operates or not when it enters the IDLE mode. This register must be programmed before executing an instruction to switch to the standby mode.

## 12.6 Data Transfer Procedure in the I2C Bus Mode

### 12.6.1 Device Initialization

First, program SBIXCR1<ACK, SCK[2:0]> by writing "0" to bits 7 to 5 in SBIXCR1.

Next, program SBIXI2CAR by specifying a slave address at <SA[6:0]> and an address recognition mode at <ALS>. (<ALS> must be set to "0" when using the addressing format).

Then program SBIXCR2 to initially configure the SBI in the slave receiver mode by writing "0" to <MST, TRX, BB> , "1" to <PIN> , "10" to <SBIM[1:0]> and "0" to bits 1 and 0.

	7	6	5	4	3	2	1	0	
SBIXCR1	←	0	0	0	X	0	X	X	X
SBIXI2CAR	←	X	X	X	X	X	X	X	X
SBIXCR2	←	0	0	0	1	1	0	0	0

(Note) X: Don't care

Specifies ACK and SCL clock.  
Specifies a slave address and an address recognition mode.  
Configures the SBI as a slave receiver.

### 12.6.2 Generating the Start Condition and a Slave Address

① Master mode

In the master mode, the following steps are required to generate the start condition and a slave address.

First, ensure that the bus is free (<BB> = "0"). Then, write "1" to SBIxCR1 <ACK> to select the acknowledgment mode. Write to SBIxDBR a slave address and a direction bit to be transmitted.

When <BB> = "0," writing "1111" to SBIxCR2 <MST, TRX, BB, PIN> generates the start condition on the bus. Following the start condition, the SBI generates nine clocks from the SCL pin. The SBI outputs the slave address and the direction bit specified at SBIxDBR with the first eight clocks, and releases the SDA line in the ninth clock to receive an acknowledgment signal from the slave device.

The INTSBIx interrupt request is generated on the falling of the ninth clock, and <PIN> is cleared to "0." In the master mode, the SBI holds the SCL line at the "L" level while <PIN> is "0." <TRX> changes its value according to the transmitted direction bit at generation of the INTSBIx interrupt request, provided that an acknowledgment signal has been returned from the slave device.

Settings in main routine

```

          7 6 5 4 3 2 1 0
    Reg.   ← SBISR
    Reg.   ← Reg. e 0x20
    if Reg. ≠ 0x00
    Then
    SBIxCR1 ← X X X 1 0 X X X
    SBIxDBR ← X X X X X X X X
    SBIxCR2 ← 1 1 1 1 1 0 0 0
    
```

Ensures that the bus is free.

Selects the acknowledgement mode.

Specifies the desired slave address and direction.

Generates the start condition.

Example of INTSBI0 interrupt routine

Clears the interrupt request.  
 Processing  
 End of interrupt

② Slave mode

In the slave mode, the SBI receives the start condition and a slave address.

After receiving the start condition from the master device, the SBI receives a slave address and a direction bit from the master device during the first eight clocks on the SCL line. If the received address matches its slave address specified at SBIxI2CAR or is equal to the general-call address, the SBI pulls the SDA line to the “L” level during the ninth clock and outputs an acknowledgment signal.

The INTSBIx interrupt request is generated on the falling of the ninth clock, and <PIN> is cleared to “0.” In the slave mode, the SBI holds the SCL line at the “L” level while <PIN> is “0”.

**(Note) The user can only use a DMA transfer:**

- when there is only one master and only one slave and
- continuous transmission or reception is possible.

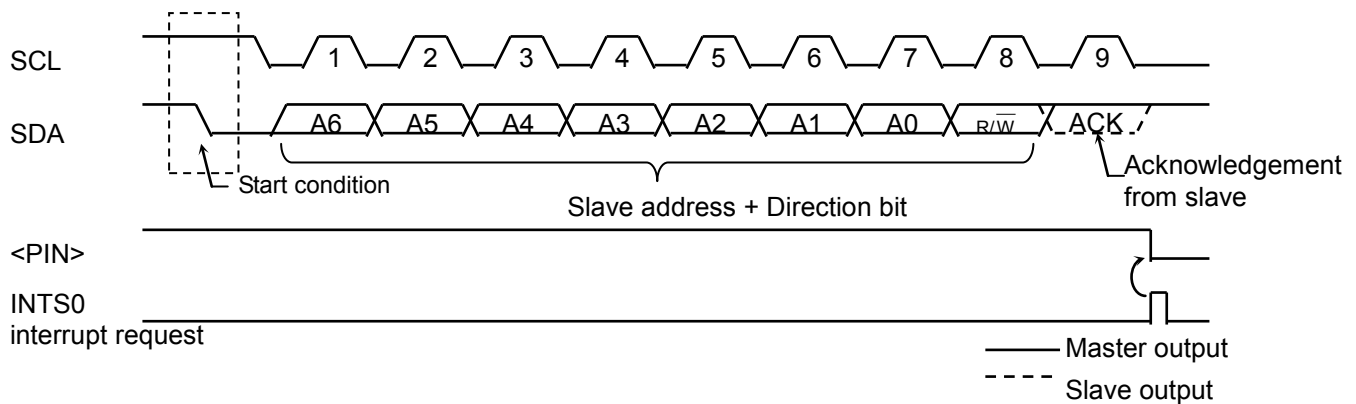

Fig. 12-14 Generation of the Start Condition and a Slave Address

### 12.6.3 Transferring a Data Word

At the end of a data word transfer, the INTSBIx interrupt is generated to test <MST> to determine whether the SBI is in the master or slave mode.

① Master mode (<MST> = “1”)

Test <TRX> to determine whether the SBI is configured as a transmitter or a receiver.

Transmitter mode (<TRX> = “1”)

Test <LRB>. If <LRB> is “1,” that means the receiver requires no further data. The master then generates the stop condition as described later to stop transmission.

If <LRB> is “0,” that means the receiver requires further data. If the next data to be transmitted has eight bits, the data is written into SBIxDBR. If the data has different length, <BC[2:0]> and <ACK> are programmed and the transmit data is written into SBIxDBR. Writing the data makes <PIN> to “1,” causing the SCL pin to generate a serial clock for transferring a next data word, and the SDA pin to transfer the data word. After the transfer is completed, the INTSBIx interrupt request is generated, <PIN> is set to “0,” and the SCL pin is pulled to the “L” level. To transmit more data words, test <LRB> again and repeat the above procedure.

INTSBIx interrupt

```

if MST = 0
Then go to the slave-mode processing
if TRX = 0
Then go to the receiver-mode processing
if LRB = 0

```

Then go to processing for generating the stop condition

SBIxCR1 ← X X X X 0 X X X      Specifies the number of bits to be transmitted and specify whether ACK is required.

SBIxDBR ← X X X X X X X X      Writes the transmit data.

End of interrupt processing

(Note)    X: Don't care

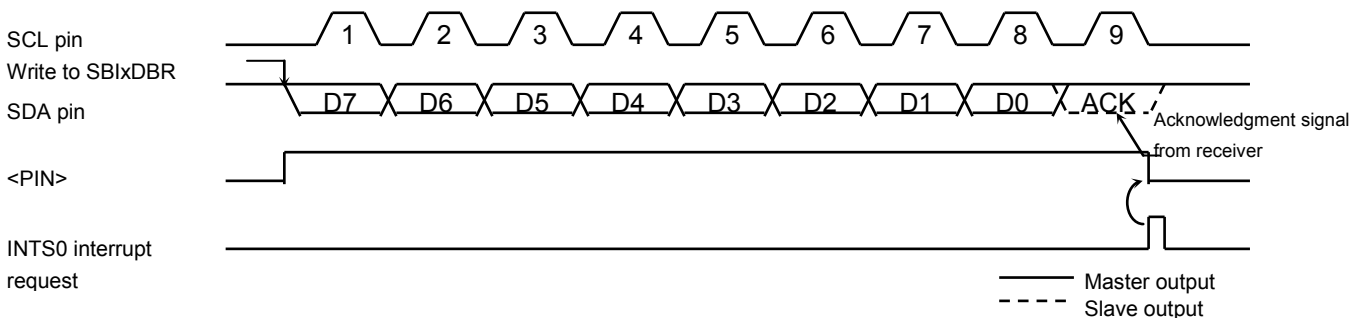
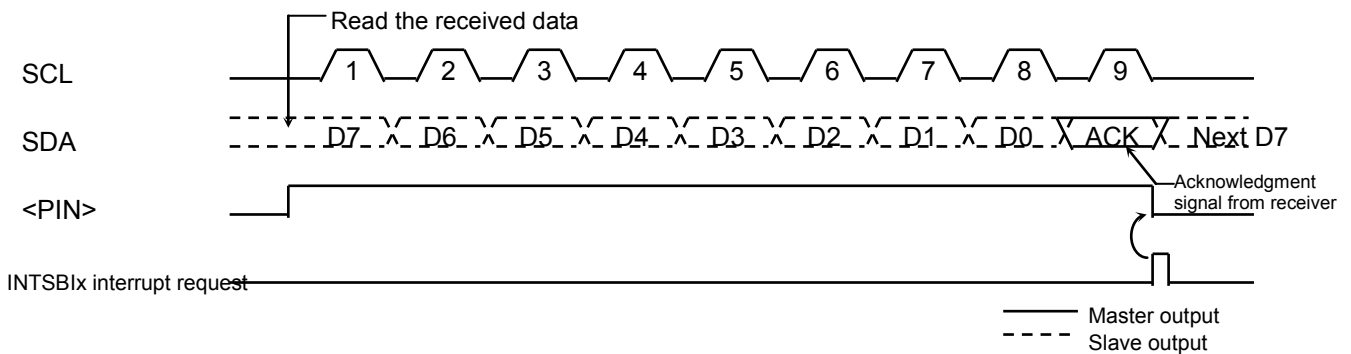

Fig. 12-15 <BC[2:0]> = “000” and <ACK> = “1” (Transmitter Mode)

Receiver mode (<TRX> = "0")

If the next data to be transmitted has eight bits, the transmit data is written into SB<sub>l</sub>xDBR. If the data has different length, <BC[2:0]> and <ACK> are programmed and the received data is read from SB<sub>l</sub>xDBR to release the SCL line. (The data read immediately after transmission of a slave address is undefined.) On reading the data, <PIN> is set to "1," and the serial clock is output to the SCL pin to transfer the next data word. In the last bit, when the acknowledgment signal becomes the "L" level, "0" is output to the SDA pin.

After that, the INTSB<sub>l</sub>x interrupt request is generated, and <PIN> is cleared to "0," pulling the SCL pin to the "L" level. Each time the received data is read from SB<sub>l</sub>xDBR, one-word transfer clock and an acknowledgment signal are output.



**Fig. 12-16 <BC[2:0]> = "000" and <ACK> = "1" (Receiver Mode)**

To terminate the data transmission from the transmitter, <ACK> must be set to "0" immediately before reading the data word second to last. This disables generation of an acknowledgment clock for the last data word. When the transfer is completed, an interrupt request is generated. After the interrupt processing, <BC[2:0]> must be set to "001" and the data must be read so that a clock is generated for 1-bit transfer. At this time, the master receiver holds the SDA bus line at the "H" level, which signals the end of transfer to the transmitter as an acknowledgment signal.

In the interrupt processing for terminating the reception of 1-bit data, the stop condition is generated to terminate the data transfer.

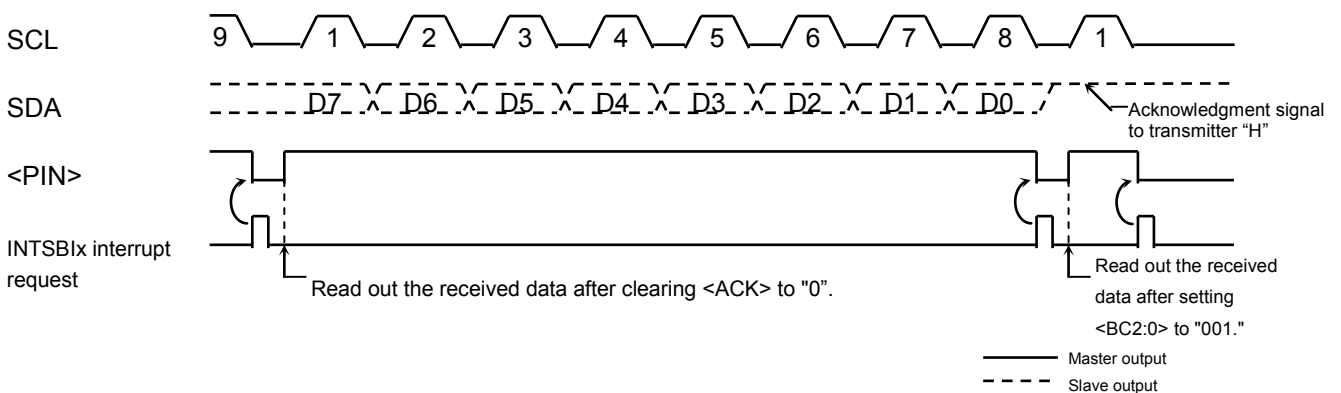

**Fig. 12-17 Terminating Data Transmission in the Master Receiver Mode**

Example: When receiving N data word

INTSBIx interrupt (after data transmission)

	7 6 5 4 3 2 1 0	
SBIxCR1	← X X X X 0 X X X	Sets the number of bits of data to be received and specify whether ACK is required.
Reg.	← SBI0DBR	Reads dummy data.
End of interrupt		

INTSBIx interrupt (first to (N-2)th data reception)

	7 6 5 4 3 2 1 0	
Reg.	← SBIxDBR	Reads the first to (N-2)th data words.
End of interrupt		

INTSBIx interrupt ((N-1)th data reception)

	7 6 5 4 3 2 1 0	
SBIxCR1	← X X X 0 0 X X X	Disables generation of acknowledgement clock.
Reg.	← SBIxDBR	Reads the (N-1)th data word.
End of interrupt		

INTSBIx interrupt (Nth data reception)

	7 6 5 4 3 2 1 0	
SBIxCR1	← 0 0 1 0 0 X X X	Disables generation of acknowledgement clock.
Reg.	← SBIxDBR	Reads the Nth data word.
End of interrupt		

INTSBIx interrupt (after completing data reception)

Processing to generate the stop condition.	Terminates the data transmission.
End of interrupt	

(Note) X: Don't care

② Slave mode (<MST> = "0")

In the slave mode, the SBI generates the INTSBIx interrupt request on four occasions: 1) when the SBI has received any slave address from the master, 2) when the SBI has received a general-call address, 3) when the received slave address matches its own address, and 4) when a data transfer has been completed in response to a general-call. Also, if the SBI detects Arbitration Lost in the master mode, it switches to the slave mode. Upon the completion of data word transfer in which Arbitration Lost is detected, the INTSBIx interrupt request is generated, <PIN> is cleared to "0," and the SCL pin is pulled to the "L" level. When data is written to or read from SBIxDBR or when <PIN> is set to "1," the SCL pin is released after a period of  $t_{LOW}$ .

In the slave mode, the normal slave mode processing or the processing as a result of Arbitration Lost is carried out.

SBIxSR <AL>, <TRX>, <AAS> and <AD0> are tested to determine the processing required.

Table **12-2** shows the slave mode states and required processing.

Example: When the received slave address matches the SBI's own address and the direction bit is "1" in the slave receiver mode.

INTSBIx interrupt

```

if TRX = 0
  Then go to other processing
if AL = 1
  Then go to other processing
if AAS = 0
  Then go to other processing
SBIxCR1 ← X X X 1 0 X X X      Sets the number of bits to be transmitted.
SBIxDBR ← X X X X 0 X X X      Sets the transmit data.

```

(Note) X: Don't care

Table 12-2 Processing in Slave Mode

<TRX>	<AL>	<AAS>	<AD0>	State	Processing
1	1	1	0	Arbitration Lost is detected while the slave address was being transmitted and the SBI received a slave address with the direction bit "1" transmitted by another master.	Set the number of bits in a data word to <BC[2:0]> and write the transmit data into SBIXDBR.
		0	0	In the slave receiver mode, the SBI received a slave address with the direction bit "1" transmitted by the master.	
	0	0	0	In the slave transmitter mode, the SBI has completed a transmission of one data word.	Test LRB. If it has been set to "1," that means the receiver does not require further data. Set <PIN> to 1 and reset <TRX> to 0 to release the bus. If <LRB> has been reset to "0," that means the receiver requires further data. Set the number of bits in the data word to <BC[2:0]> and write the transmit data to the SBIXDBR.
0	1	1	1/0	Arbitration Lost is detected while a slave address is being transmitted, and the SBI receives either a slave address with the direction bit "0" or a general-call address transmitted by another master.	Read the SBIXDBR (a dummy read) to set <PIN> to 1, or write "1" to <PIN>.
		0	0	Arbitration Lost is detected while a slave address or a data word is being transmitted, and the transfer is terminated.	
	0	1	1/0	In the slave receiver mode, the SBI received either a slave address with the direction bit "0" or a general-call address transmitted by the master.	
		0	1/0	In the slave receiver mode, the SBI has completed a reception of a data word.	

### 12.6.4 Generating the Stop Condition

When SBIxSR <BB> is "1," writing "1" to SBIxCR2 <MST, TRX, PIN> and "0" to <BB> causes the SBI to start a sequence for generating the stop condition on the bus. Do not alter the contents of <MST, TRX, BB, PIN> until the stop condition appears on the bus.

If another device is holding down the SCL bus line, the SBI waits until the SCL line is released. After that, the SDA pin goes high, causing the stop condition to be generated.

7 6 5 4 3 2 1 0  
SBIxCR2 ← 1 1 0 1 1 0 0 0      Generates the stop condition.

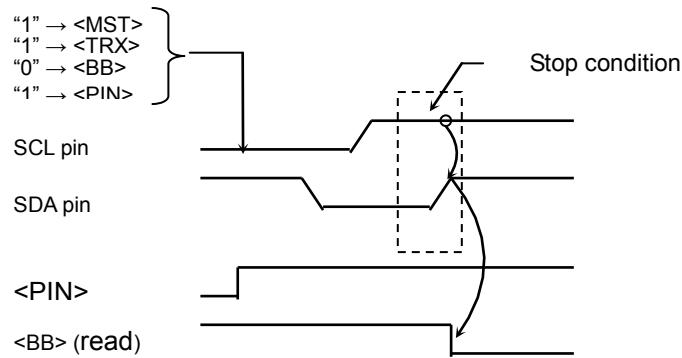

Fig. 12-18 Generating the Stop Condition

**12.6.5 Restart Procedure**

Restart is used when a master device changes the data transfer direction without terminating the transfer to a slave device. The procedure of generating a restart in the master mode is described below.

First, set SBIxCR2 <MST, TRX, BB> to “0” and write “1” to <PIN> to release the bus. At this time, the SDA pin is held at the “H” level and the SCL pin is released. Because no stop condition is generated on the bus, other devices recognize that the bus is busy. Then, test SBIxSR <BB> and wait until it becomes “0” to ensure that the SCL pin is released. Next, test <LRB> and wait until it becomes “1” to ensure that no other device is pulling the SCL bus line to the “L” level. Once the bus is determined to be free this way, use the above-mentioned steps 12.6.2 to generate the start condition.

To satisfy the setup time of restart, at least 4.7-μs wait period (in the standard mode) must be created by the software after the bus is determined to be free.

```

    7 6 5 4 3 2 1 0
    ┌ SBIxCR2 ← 0 0 0 1 1 0 0 0
    │ if SBIxSR<BB> ≠ 0
    └─┘ Releases the bus.
        Checks that the SCL pin is released.
    ┌ Then
    │ if SBIxSR<LRB> ≠ 1
    └─┘ Checks that no other device is pulling the SCL pin to the
        “L” level.

    Then
    4.7 μs Wait
    SBIxCR1 ← X X X 1 0 X X X
    SBIxDBR ← X X X X X X X X
    SBIxCR2 ← 1 1 1 1 1 0 0 0
    └─┘ Selects the acknowledgment mode.
        Sets the desired slave address and direction.
        Generates the start condition.
    
```

(Note) X: Don't care

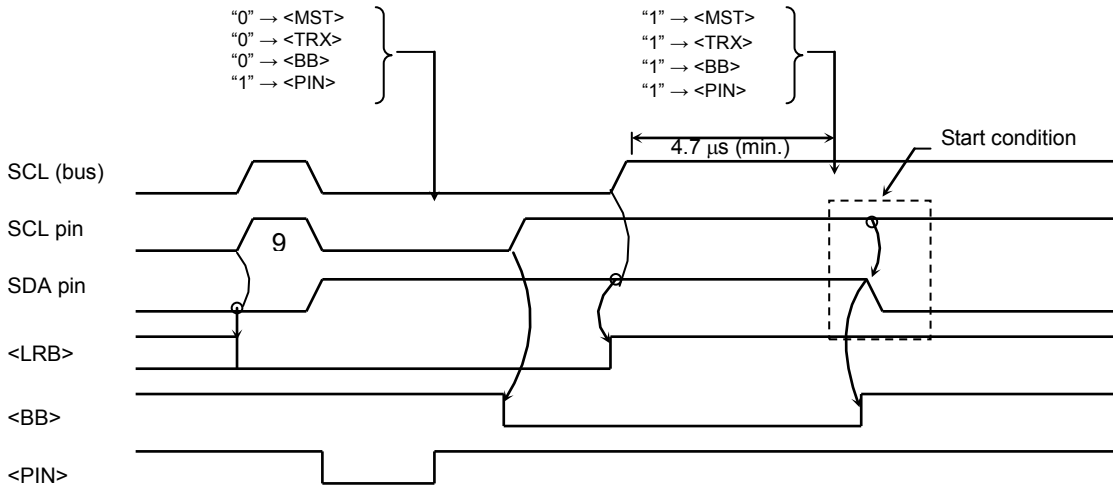

**(Note) Do not write <MST> to “0” when it is “0.” (Restart cannot be initiated.)**

**Fig. 12-19 Timing Chart of Generating a Restart**

### 12.7 Control in the Clock-synchronous 8-bit SIO Mode

The following registers control the serial bus interface in the clock-synchronous 8-bit SIO mode and provide its status information for monitoring.

Serial bus interface control register 0

		7	6	5	4	3	2	1	0
SBIxCR0	bit Symbol	SBIEN							
	Read/Write	R/W	R						
	After reset	0							
	Function	SBI operation 0: Disable 1: Enable	This can be read as "0."						
		15	14	13	12	11	10	9	8
	bit Symbol								
	Read/Write	R							
	After reset	0							
	Function	This can be read as "0."							
		23	22	21	20	19	18	17	16
	bit Symbol								
	Read/Write	R							
	After reset	0							
	Function	This can be read as "0."							
		31	30	29	28	27	26	25	24
	bit Symbol								
	Read/Write	R							
	After reset	0							
	Function	This can be read as "0."							

<SBIEN>: To use the SBI, enable the SBI operation ("1") before setting each register of SBI module.

**Fig. 12-20 SIO Mode Registers**

Serial bus interface control register 1

SBIxCR1	bit Symbol	7	6	5	4	3	2	1	0
	Read/Write	SIOS	SIOINH	SIOM1	SIOM0		SCK2	SCK1	SCK0
	After reset	R/W				R	R/W		
	Function	0	0	0	0	1	0	0	0
	Function	Start transfer 0: Stop 1: Start	Transfer 0: Continue 1: Forced termination	Select transfer mode 00: Transmit mode 01: (Reserved) 10: Transmit/receive mode 11: Receive mode		This can be read as "1".	Select serial clock frequency		
bit Symbol	15	14	13	12	11	10	9	8	
Read/Write	R								
After reset	0								
Function	This can be read as "0".								
bit Symbol	23	22	21	20	19	18	17	16	
Read/Write	R								
After reset	0								
Function	This can be read as "0".								
bit Symbol	31	30	29	28	27	26	25	24	
Read/Write	R								
After reset	0								
Function	This can be read as "0".								

On writing <SCK2:0>: Select serial clock frequency

000	n = 3	2.5 MHz	$\left( \begin{array}{l} \text{System clock} : f_{\text{sys}} \\ \text{Clock gear} : fc/1 \\ \text{Frequency} : \frac{f_{\text{sys}}/2^n}{2} \text{ [ Hz ]} \end{array} \right)$
001	n = 4	1.25 MHz	
010	n = 5	625 kHz	
011	n = 6	313 kHz	
100	n = 7	156 kHz	
101	n = 8	78 kHz	
110	n = 9	39 kHz	
111	—	External clock	

**(Note1)** After a reset, the <SCK[0]> bit is read as "1". However, if the SIO mode is selected at the SBIxCR2 register, the initial value is read as "0". In this document, the value written in the column "after reset" is the value after setting the SIO mode in the initial state. The descriptions of the SBIxCR2 register and SBIxSR register are the same.

**(Note2)** Set <SIOS> to "0" and <SIOINH> to "1" before programming the transfer mode and the serial clock.

Fig. 12-21 SIO Mode Registers

Serial bus interface data buffer register

SBlxDBR

	7	6	5	4	3	2	1	0
bit Symbol	DB7	DB6	DB5	DB4	DB3	DB2	DB1	DB0
Read/Write	R (Receive)/W (Transmit)							
After reset	0							
Function	RX data/ TX data							
	15	14	13	12	11	10	9	8
bit Symbol								
Read/Write	R							
After reset	0							
Function	This can be read as "0".							
	23	22	21	20	19	18	17	16
bit Symbol								
Read/Write	R							
リセット後	0							
機能	This can be read as "0".							
	31	30	29	28	27	26	25	24
bit Symbol								
Read/Write	R							
After reset	0							
Function	This can be read as "0".							

Serial bus interface control register 2

SBlxCR2

	7	6	5	4	3	2	1	0
bit Symbol					SBIM1	SBIM0		
Read/Write	R				W		R	
After reset	1				0	0	1	
Function	This can be read as "1".				Select serial bus interface operating mode 00: Port mode 01: Clock-synchronous 8-bit SIO mode 10: I <sup>2</sup> C bus mode 11: (Reserved)		This can be read as "1".	
	15	14	13	12	11	10	9	8
bit Symbol								
Read/Write	R							
After reset	0							
Function	This can be read as "0".							
	23	22	21	20	19	18	17	16
bit Symbol								
Read/Write	R							
After reset	0							
Function	This can be read as "0".							
	31	30	29	28	27	26	25	24
bit Symbol								
Read/Write	R							
After reset	0							
Function	This can be read as "0".							

Fig. 12-22 SIO Mode Registers

Serial bus interface register

SBIXSR		7	6	5	4	3	2	1	0	
	bit Symbol					SIOF	SEF			
	Read/Write	R				R		R		
	After reset	1				0	0	1		
Function	This can be read as "1".				Serial transfer status monitor 0: Completed 1: In progress	Shift operation status monitor 0: Completed 1: In progress	This can be read as "1".			
		15	14	13	12	11	10	9	8	
bit Symbol										
Read/Write	R									
After reset	0									
Function	This can be read as "0".									
		23	22	21	20	19	18	17	16	
bit Symbol										
Read/Write	R									
After reset	0									
Function	This can be read as "0".									
		31	30	29	28	27	26	25	24	
bit Symbol										
Read/Write	R									
After reset	0									
Function	This can be read as "0".									

Serial bus interface baud rate register 0

SBIXBR0		7	6	5	4	3	2	1	0	
	bit Symbol		I2SBI							
	Read/Write	R	R/W	R						W
	After reset	1	0	1						0
Function	This can be read as "1".	IDLE 0: Stop 1: Operate	This can be read as "1".						Make sure to write "0".	
		15	14	13	12	11	10	9	8	
bit Symbol										
Read/Write	R									
After reset	0									
Function	This can be read as "0".									
		23	22	21	20	19	18	17	16	
bit Symbol										
Read/Write	R									
After reset	0									
Function	This can be read as "0".									
		31	30	29	28	27	26	25	24	
bit Symbol										
Read/Write	R									
After reset	0									
Function	This can be read as "0".									

Fig. 12-23 SIO Mode Registers

### 12.7.1 Serial Clock

① Clock source

Internal or external clocks can be selected by programming SBlxCR1 <SCK[2:0]>.

Internal clocks

In the internal clock mode, one of the seven frequencies can be selected as a serial clock, which is output to the outside through the SCK pin. At the beginning of a transfer, the SCK pin output becomes the “H” level.

If the program cannot keep up with this serial clock rate in writing the transmit data or reading the received data, the SBI automatically enters a wait period. During this period, the serial clock is stopped automatically and the next shift operation is suspended until the processing is completed.

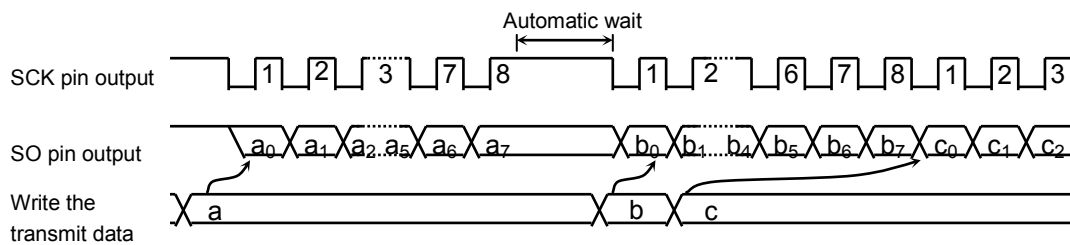

**Fig. 12-24 Automatic Wait**

External clock (<SCK[2:0]> = “111”)

The SBI uses an external clock supplied from the outside to the SCK pin as a serial clock. For proper shift operations, the serial clock at the “H” and “L” levels must have the pulse widths as shown below.

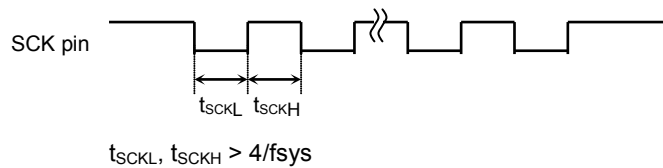

**Fig. 12-25 Maximum Transfer Frequency of External Clock Input**

② Shift Edge

Leading-edge shift is used in transmission. Trailing-edge shift is used in reception.

Leading-edge shift

Data is shifted at the leading edge of the serial clock (or the falling edge of the SCK pin input/output).

Trailing-edge shift

Data is shifted at the trailing edge of the serial clock (or the rising edge of the SCK pin input/output).

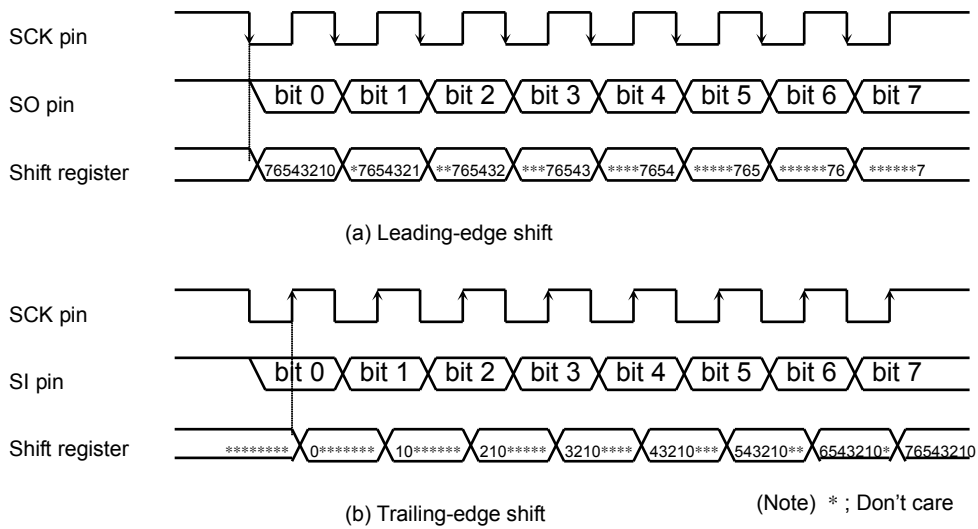

**Fig. 12-26 Shift Edge**

## 12.7.2 Transfer Modes

The transmit mode, the receive mode or the transmit/receive mode can be selected by programming SBIXCR1 <SIOM[1:0]>.

### ① 8-bit transmit mode

Set the control register to the transmit mode and write the transmit data to SBIXDBR.

After writing the transmit data, writing “1” to SBIXCR1 <SIOS> starts the transmission. The transmit data is moved from SBIXDBR to a shift register and output to the SO pin, with the least-significant bit (LSB) first, in synchronization with the serial clock. Once the transmit data is transferred to the shift register, SBIXDBR becomes empty, and the INTSBIX (buffer-empty) interrupt is generated, requesting the next transmit data.

In the internal clock mode, the serial clock will be stopped and automatically enter the wait state, if next data is not loaded after the 8-bit data has been fully transmitted. The wait state will be cleared when SBIXDBR is loaded with the next transmit data.

In the external clock mode, SBIXDBR must be loaded with data before the next data shift operation is started. Therefore, the data transfer rate varies depending on the maximum latency between when the interrupt request is generated and when SBIXDBR is loaded with data in the interrupt service program.

At the beginning of transmission, the same value as in the last bit of the previously transmitted data is output in a period from setting SBIXSR <SIOF> to “1” to the falling edge of SCK.

Transmission can be terminated by clearing <SIOS> to “0” or setting <SIOINH> to “1” in the INTSBIX interrupt service program. If <SIOS> is cleared, remaining data is output before transmission ends. The program checks SBIXSR <SIOF> to determine whether transmission has come to an end. <SIOF> is cleared to “0” at the end of transmission. If <SIOINH> is set to “1,” the transmission is aborted immediately and <SIOF> is cleared to “0”.

In the external clock mode, <SIOS> must be set to “0” before the next transmit data shift operation is started. Otherwise, operation will stop after dummy data is transmitted.

	7 6 5 4 3 2 1 0	
SBIXCR1	← 0 1 0 0 0 X X X	Selects the transmit mode.
SBIXDBR	← X X X X X X X X	Writes the transmit data.
SBIXCR1	← 1 0 0 0 0 X X X	Starts transmission.
INTSBIX interrupt		
SBIXDBR	← X X X X X X X X	Writes the transmit data.

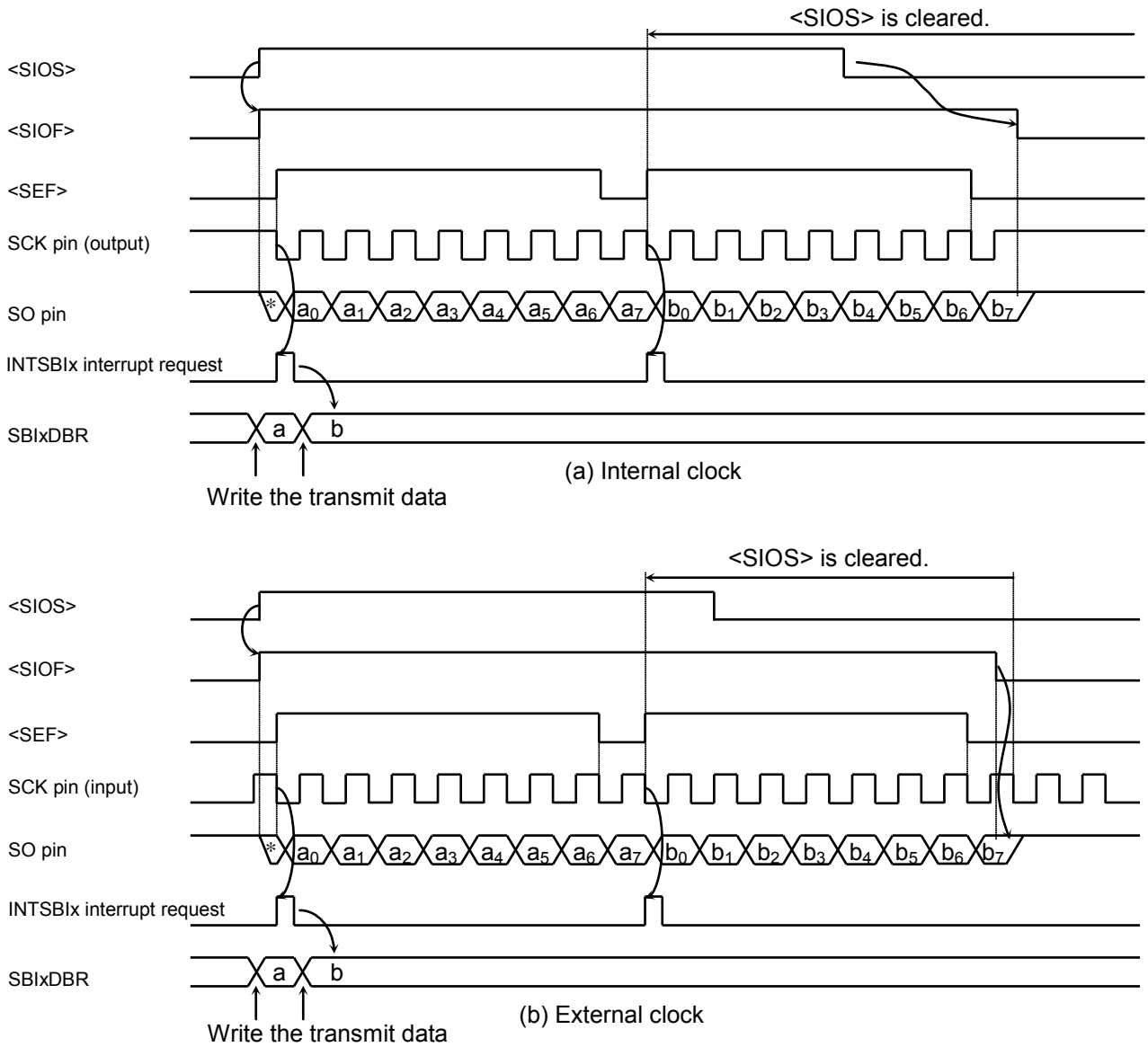

Fig. 12-27 Transmit Mode

Example: Example of programming (external clock) to terminate transmission by <SIO>

```

    7 6 5 4 3 2 1 0
    ┌ if SBISR<SIOF> ≠ 0           Recognizes the completion of the transmission.
    │ Then
    └ if SCK ≠ 1                   Recognizes "1" is set to the SCK pin by monitoring the port.
    │ Then
    └ SBIXCR1 ← 0 0 0 0 0 1 1 1    Completes the transmission by setting <SIOS> = 0.
    
```

## ② 8-bit receive mode

Set the control register to the receive mode. Then writing "1" to SB<sub>I</sub>xCR1 <SIOS> enables reception. Data is taken into the shift register from the SI pin, with the least-significant bit (LSB) first, in synchronization with the serial clock. Once the shift register is loaded with the 8-bit data, it transfers the received data to SB<sub>I</sub>xDBR and the INTSB<sub>I</sub>x (buffer-full) interrupt request is generated to request reading the received data. The interrupt service program then reads the received data from SB<sub>I</sub>xDBR.

In the internal clock mode, the serial clock will be stopped and automatically be in the wait state until the received data is read from SB<sub>I</sub>xDBR.

In the external clock mode, shift operations are executed in synchronization with the external clock. The maximum data transfer rate varies, depending on the maximum latency between generating the interrupt request and reading the received data.

Reception can be terminated by clearing <SIOS> to "0" or setting <SIOINH> to "1" in the INTSB<sub>I</sub>x interrupt service program. If <SIOS> is cleared, reception continues until all the bits of received data are written to SB<sub>I</sub>xDBR. The program checks SB<sub>I</sub>xSR <SIOF> to determine whether reception has come to an end. <SIOF> is cleared to "0" at the end of reception. After confirming the completion of the reception, last received data is read. If <SIOINH> is set to "1," the reception is aborted immediately and <SIOF> is cleared to "0." (The received data becomes invalid, and there is no need to read it out.)

**(Note) The contents of SB<sub>I</sub>xDBR will not be retained after the transfer mode is changed. The ongoing reception must be completed by clearing <SIOS> to "0" and the last received data must be read before the transfer mode is changed.**

7 6 5 4 3 2 1 0	SB <sub>I</sub> xCR1 ← 0 1 1 1 0 X X X	Selects the receive mode.
-----------------	--	---------------------------

7 6 5 4 3 2 1 0	SB <sub>I</sub> xCR1 ← 1 0 1 1 0 X X X	Starts reception.
-----------------	--	-------------------

INTSB<sub>I</sub>x interrupt

Reg.	← SB <sub>I</sub> xDBR	Reads the received data.
------	------------------------	--------------------------

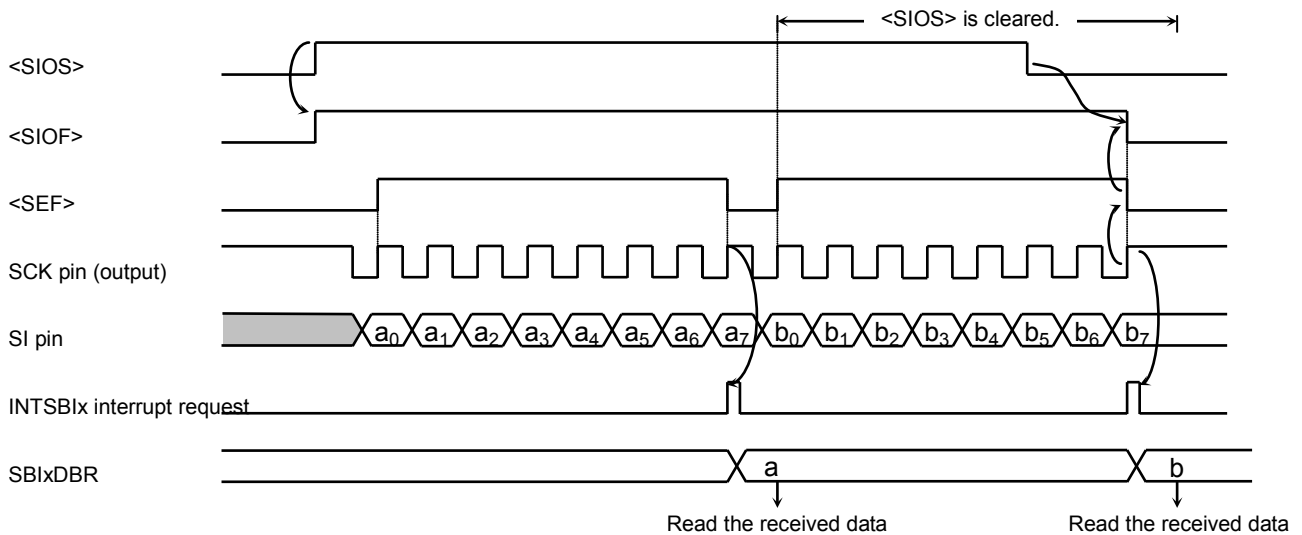

**Fig. 12-28 Receive Mode (Example: Internal Clock)**

③ 8-bit transmit/receive mode

Set the control register to the transfer/receive mode. Then writing the transmit data to SBIXDBR and setting SBIXCR1 <SIOS> to “1” enables transmission and reception. The transmit data is output through the SO pin at the falling of the serial clock, and the received data is taken in through the SI pin at the rising of the serial clock, with the least-significant bit (LSB) first. Once the shift register is loaded with the 8-bit data, it transfers the received data to SBIXDBR and the INTSBIx interrupt request is generated. The interrupt service program reads the received data from the data buffer register and writes the next transmit data. Because SBIXDBR is shared between transmit and receive operations, the received data must be read before the next transmit data is written.

In the internal clock operation, the serial clock will be automatically in the wait state until the received data is read and the next transmit data is written.

In the external clock mode, shift operations are executed in synchronization with the external serial clock. Therefore, the received data must be read and the next transmit data must be written before the next shift operation is started. The maximum data transfer rate for the external clock operation varies depending on the maximum latency between when the interrupt request is generated and when the transmit data is written.

At the beginning of transmission, the same value as in the last bit of the previously transmitted data is output in a period from setting <SIOF> to “1” to the falling edge of SCK. Transmission and reception can be terminated by clearing <SIOS> to “0” or setting SBIXCR1 <SIOINH> to “1” in the INTSBIx interrupt service program. If <SIOS> is cleared, transmission and reception continue until the received data is fully transferred to SBIXDBR. The program checks SBIXSR <SIOF> to determine whether transmission and reception have come to an end. <SIOF> is cleared to “0” at the end of transmission and reception. If <SIOINH> is set, the transmission and reception are aborted immediately and <SIOF> is cleared to “0.”

**(Note)** The contents of SBIXDBR will not be retained after the transfer mode is changed. The ongoing transmission and reception must be completed by clearing <SIOS> to “0” and the last received data must be read before the transfer mode is changed.

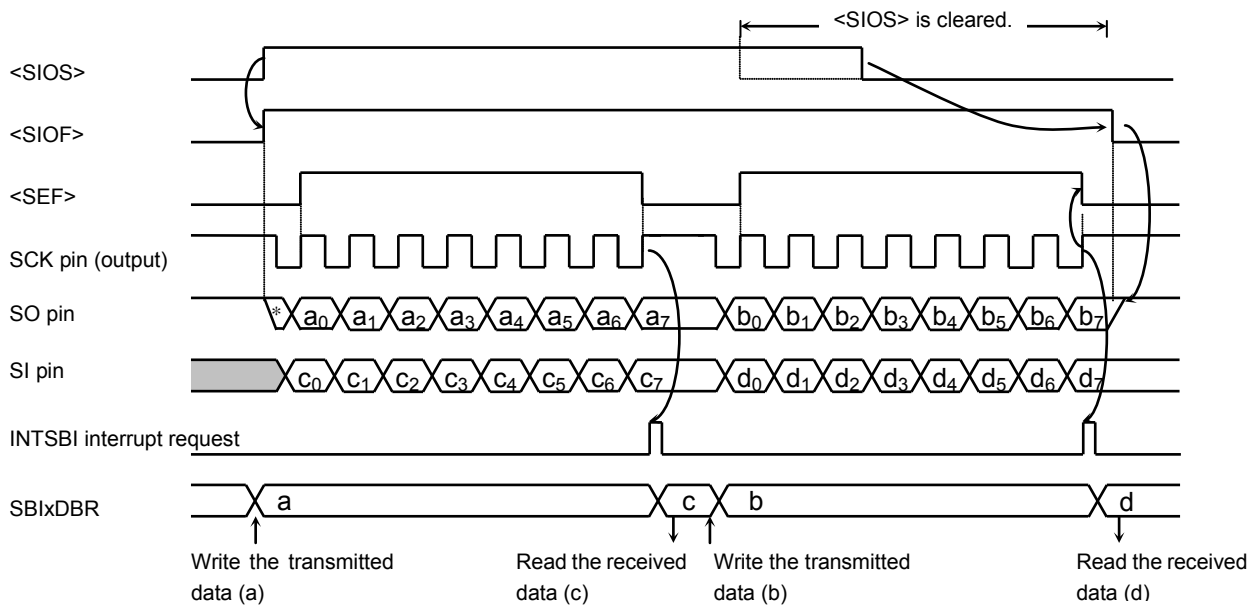

**Fig. 12-29 Transmit/Receive Mode (Example: Internal Clock)**

7 6 5 4 3 2 1 0  
 SBIXCR1 ← 0 1 1 0 0 X X X      Selects the transmit/receive mode.

SBIXDBR ← X X X X X X X X      Writes the transmit data.  
 SBIXCR1 ← 1 0 1 0 0 X X X      Starts reception/transmission.

**INTSBIx interrupt**

Reg. ← SBIXDBR      Reads the received data.  
 SBIXDBR ← X X X X X X X X      Writes the transmit data.

## 13 Consumer Electronics Control (CEC)

### 13.1 Outline

This IP enables to transmit or receive data that conforms to Consumer Electronics Control (hereafter referred to as CEC) protocol (conforms to HDMI 1.3a specifications).

#### 13.1.1 Reception

- Clock sampling at 32KHz
  - Adjustable noise canceling time
- Data reception per 1byte
  - Flexible data sampling point
  - Data reception is available even when an address discrepancy is detected.
- Error detection
  - Cycle error (min./ max.)
  - ACK collision
  - Waveform error

#### 13.1.2 Transmission

- Data transmission per 1byte
  - Triggered by auto-detection of bus free state
- Flexible waveform
  - Adjustable rising edge and cycle
- Error detection
  - Arbitration lost
  - ACK response error

#### 13.1.3 Precautions

Be careful about the following in the receive operation.

Address condition	Setting of CECRCR1<CECOTH>	Precautions
Logical address match	—	If the initiator sends a new message beginning with the start bit without having sent the last block with EOM="1", a maximum cycle error is determined for the ACK bit and an interrupt is generated. Then, the receive operation is performed in the usual way.
Logical address discrepancy	When data reception at logical address discrepancy is enabled. (CECRCR1<CECOTH>="1")	
	When data reception at logical address discrepancy is disabled. (CECRCR1<CECOTH>="0")	The initiator must send the last block of data with the EOM bit set to "1". If the last block is sent with EOM="0", the subsequent operation cannot be guaranteed.

## 13.2 Registers

### 13.2.1 Control Registers and Addresses

The control registers and address for CEC are as follows.

Registers		Addresses
CEC Enable Register	CECEN	0x4004_0300
Logical Address Register	CECADD	0x4004_0304
Software Reset Register	CECRESET	0x4004_0308
Receive Enable Register	CECREN	0x4004_030C
Receive Buffer Register	CECRBUF	0x4004_0310
Receive Control Register 1	CECR1	0x4004_0314
Receive Control Register 2	CECR2	0x4004_0318
Receive Control Register 3	CECR3	0x4004_031C
Transmit Enable Register	CECTEN	0x4004_0320
Transmit Buffer Register	CECTBUF	0x4004_0324
Transmit Control Register	CECTCR	0x4004_0328
Receive Interrupt Status Register	CECRSTAT	0x4004_032C
Transmit Interrupt Status Register	CECTSTAT	0x4004_0330
CEC Sampling Clock Delected Register	CECFSEL	0x4004_0334

### 13.2.2 CEC Enable Register [CECEN]

	7	6	5	4	3	2	1	0
bit Symbol	—						—	CECEN
Read/Write	R						R/W	R/W
After reset	0						0	0
Function	"0" is read.						Write as "1".	CEC operation  0: Disabled 1: Enabled

<CECEN>: Specifies the CEC operation.

Enable CEC before using.

When the CEC operation is disabled, no clocks are supplied to the CEC module except for the enable register. Thus power consumption can be reduced.

When CEC is disabled after it was enabled, each register setting is maintained.

### 13.2.3 Logical Address Register [CECADD]

	15	14	13	12	11	10	9	8
bit Symbol	CECADD 15	CECADD 14	CECADD 13	CECADD 12	CECADD 11	CECADD 10	CECADD 9	CECADD 8
Read/Write	R/W							
After reset	0							
Function	Logical address 15	Logical address 14	Logical address 13	Logical address 12	Logical address 11	Logical address 10	Logical address 9	Logical address 8

	7	6	5	4	3	2	1	0
bit Symbol	CECADD 7	CECADD 6	CECADD 5	CECADD 4	CECADD 3	CECADD 2	CECADD 1	CECADD 0
Read/Write	R/W							
After reset	0							
Function	Logical address 7	Logical address 6	Logical address 5	Logical address 4	Logical address 3	Logical address 2	Logical address 1	Logical address 0

<CECADD[15:0]>: Specifies the logical address assigned to CEC.

Multiple addresses can be set simultaneously since each bit corresponds with each address.

**(Note)** A broadcast message is received regardless of the register setting. By allocating a logical address of a device to 15, logical "0" is sent as an ACK response to the broadcast message.

13.2.4 Software Reset Register [CECRESET]

	7	6	5	4	3	2	1	0
bit Symbol	—							CEC RESET
Read/Write	R							W
After reset	0							0
Function	"0" is read.							Software reset 0: Disabled 1: Enabled  "0" is read.

<CECRESET>: Stops all the CEC operation and initializes the register.  
 Setting this bit to "1" affects as follows:  
 Reception: Stops immediately. The received data is discarded.  
 Transmission (including the CEC line): Stops immediately.  
 Register: All the registers other than CECEN are initialized.

13.2.5 Receive Enable Register [CECREN]

	7	6	5	4	3	2	1	0
bit Symbol	—							CECREN
Read/Write	R							R/W
After reset	0							Undefined
Function	"0" is read.							Receptio n control  [Write] 0: Disabled 1: Enabled [Read] 0: Stopped 1: in operation

<CECREN>: Controls the reception operation of CEC.  
 Writing "0" or "1" to this bit enables or disables data reception. This bit becomes ready for data reception by writing "1".  
 The state of the reception circuit is monitored by reading this bit. It enables you to check if what you set has properly been reflected.

- (Note 1) Enable the <CECREN> bit after setting the reception control register 1, 2 and 3.
- (Note 2) It takes a little time to reflect the setting of the <CECREN> bit to the circuit. Stop transmission and reception before changing the settings or enabling the transmission and reception.

**13.2.6 Receive Buffer Register [CECRBUF]**

	15	14	13	12	11	10	9	8
bit Symbol	—						CECACK	CECEOM
Read/Write	R						R	R
After reset	0						0	0
Function	"0" is read.						ACK bit	EOM bit
	7	6	5	4	3	2	1	0
bit Symbol	CECRBUF 7	CECRBUF 6	CECRBUF 5	CECRBUF 4	CECRBUF 3	CECRBUF 2	CECRBUF 1	CECRBUF 0
Read/Write	R							
After reset	0							
Function	Received data							

<CECACK>: Reads the received ACK bit.

<CECEOM>: Reads the received EOM bit.

<CECRBUF[7:0]>: Reads one byte of data received. The bit 7 is the MSB.

**(Note 1) Writing to this register is ignored.**

**(Note 2) Read this register as soon as a receive interrupt is generated. The subsequent reading data may not be ensured.**

13.2.7 Receive Control Register 1 [CECRCR1]

	31	30	29	28	27	26	25	24
bit Symbol	—							CECACK DIS
Read/Write	R							R/W
After reset	0							0
Function	"0" is read.							Logical "0" as ACK response 0: send 1: not send
	23	22	21	20	19	18	17	16
bit Symbol	—		CECHNC 1	CECHNC 0	—	CECLNC 2	CECLNC 1	CECLNC 0
Read/Write	R		R/W		R	R/W		
After reset	0		0		0	0		
Function	"0" is read.		The number of "1" samplings for noise cancellation. 00: 1 01: 2 10: 3 11: 4		"0" is read.	The number of "0" samplings for noise cancellation. 000: 1 001: 2 010: 3 011: 4 100: — (Reserved) 101: — (Reserved) 110: — (Reserved) 111: — (Reserved)		
	15	14	13	12	11	10	9	8
bit Symbol	—	CECMIN2	CECMIN1	CECMIN0	—	CECMAX 2	CECMAX 1	CECMAX 0
Read/Write	R	R/W			R	R/W		
After reset	0	0			0	0		
Function	"0" is read.	Time to identify as min. cycle error 000: 2.05ms 001: 2.05ms+1cycle 010: 2.05ms+2cycles 011: 2.05ms+3cycles 100: 2.05ms-1cycle 101: 2.05ms-2cycles 110: 2.05ms-3cycles 111: 2.05ms-4cycles			"0" is read.	Time to identify as max. cycle error 000: 2.75ms 001: 2.75ms+1cycle 010: 2.75ms+2cycles 011: 2.75ms+3cycles 100: 2.75ms-1cycle 101: 2.75ms-2cycles 110: 2.75ms-3cycles 111: 2.75ms-4cycles		
	7	6	5	4	3	2	1	0
bit Symbol	—	CECDAT 2	CECDAT 1	CECDAT 0	CECTOU T1	CECTOU T0	CECRI HLD	CECOTH
Read/Write	R	R/W			R/W		R/W	R/W
After reset	0	0			0		0	0
Function	"0" is read.	Point of determining the data as 0 or 1. 000: 1.05ms 001: 1.05ms+2cycles 010: 1.05ms+4cycles 011: 1.05ms+6cycles 100: 1.05ms-2cycles 101: 1.05ms-4cycles 110: 1.05ms-6cycles 111: Reserved			Cycle to identify timeout 00: 1 bit cycle 01: 2 bit cycles 10: 3 bit cycles 11: Reserved		Error interrupt suspend 0: Yes 1: No	Data reception at logical address discrepan cy 0: Yes 1: No

- <CECACKDIS>: Specifies if logical “0” is sent or not as an ACK response to the data block when destination address corresponds with the address set in the logical address register. (The header block sends logical “0” as an ACK response regardless of the bit setting when detecting the addresses corresponding).
- <CECHNC[1:0]>: Specifies the time of the noise cancellation for each sampling clock cycle when detecting “1”.  
It is considered as noise if “1”s of the same number as the specified cycles are not sampled.
- <CECLNC[2:0]>: Specifies the time of the noise cancellation for each sampling clock cycle when detecting “0”.  
It is considered as noise if “0”s of the same number as the specified cycles are not sampled.
- <CECMIN[2:0]>: Specifies the minimum time to identify a valid bit.  
Enables to specify it for each sampling clock cycle between the ranges of -4 to +3 cycles from approx. 2.05 ms.  
An interrupt is generated and “0” is output to CEC for approx. 3.6 ms when one bit cycle is shorter than the specified time.
- <CECMAX[2:0]>: Specifies the maximum time to identify a valid bit.  
Enables to specify it for each sampling clock cycle between the ranges of -4 to +3 cycles from approx. 2.75 ms.  
An interrupt is generated when one bit cycle is longer than the specified time.
- <CECDAT[2:0]>: Specifies the point of determining the data as 0 or 1.  
Enables to specify it per two sampling clock cycles between the ranges of + or - 6 cycles from approx. 1.05 ms.
- <CECTOUT[1:0]>: Specifies the time to determine a timeout. Enables to specify it between 1 bit and 3 bits for each bit cycle.  
This setting is used to detect a timeout occurs when the <CECRIHLD> bit is valid.
- <CECRIHLD>: Specifies if a receive error interrupt (maximum cycle error, buffer overrun and waveform error) is suspended or not.  
Setting “1” generates no interrupt at the error detection. If data continues to an ACK bit, an ACK response is executed by a reversed logic. If the subsequent bits are interrupted, it is determined as a timeout, based on the setting in <CECTOUT>.  
After the ACK response or the timeout determination, an interrupt is generated.
- <CECOTH>: Specifies if data is received or not when destination address does not correspond with the address set in the logical address register.

- (Note 1)** The settings in <CECHNC>, <CECLNC> and <CECDAT> are also used in receiving an ACK response at transmission.
- (Note 2)** Changing the configurations during transmission or reception may harm its proper operation. Before the change, set the CECREN <CECREN> bit to disable the reception and read the <CECREN> bit and the CECTEN <CECTRANS> bit to ensure that the operation is stopped.
- (Note 3)** A broadcast message is received regardless of the <CECOTH> register setting.
- (Note 4)** <CECLNC> must be used under the same setting as CECTCR<CECDTRS>.

## 13.2.8 Receive Control Register 2 [CECR2]

	15	14	13	12	11	10	9	8
bit Symbol	—	CEC SWAV32	CEC SWAV31	CEC SWAV30	—	CEC SWAV22	CEC SWAV21	CEC SWAV20
Read/Write	R	R/W			R	R/W		
After reset	0	0			0	0		
Function	"0" is read.	Max. cycle to detect start bit 000: 4.7ms 001: 4.7ms+1cycle 010: 4.7ms+2cycles 011: 4.7ms+3cycles 100: 4.7ms+4cycles 101: 4.7ms+5cycles 110: 4.7ms+6cycles 111: 4.7ms+7cycles			"0" is read.	Min. cycle to detect start bit 000: 4.3ms 001: 4.3ms-1cycle 010: 4.3ms-2cycles 011: 4.3ms-3cycles 100: 4.3ms-4cycles 101: 4.3ms-5cycles 110: 4.3ms-6cycles 111: 4.3ms-7cycles		
	7	6	5	4	3	2	1	0
bit Symbol	—	CEC SWAV12	CEC SWAV11	CEC SWAV10	—	CEC SWAV02	CEC SWAV01	CEC SWAV00
Read/Write	R	R/W			R	R/W		
After reset	0	0			0	0		
Function	"0" is read.	Max. time of start bit rising timing. 000: 3.9ms 001: 3.9ms+1cycle 010: 3.9ms+2cycles 011: 3.9ms+3cycles 100: 3.9ms+4cycles 101: 3.9ms+5cycles 110: 3.9ms+6cycles 111: 3.9ms+7cycles			"0" is read.	Min. time of start bit rising timing. 000: 3.5ms 001: 3.5ms-1cycle 010: 3.5ms-2cycles 011: 3.5ms-3cycles 100: 3.5ms-4cycles 101: 3.5ms-5cycles 110: 3.5ms-6cycles 111: 3.5ms-7cycles		

- <CECSWAV3 [2:0]>: Specifies the cycles to detect a start bit.  
 <CECSWAV2 [2:0]>: <CECSWAV3> is for the maximum cycles. Enables to set it for each sampling clock cycle between the ranges of 0 to +7 cycles from default value (4.7 ms).  
 <CECSWAV2> is for the minimum cycles. Enables to set it for each sampling clock cycle between the ranges of 0 to +7 cycles from default value (4.3 ms).
- <CECSWAV1 [2:0]>: Specifies the rising timing of a start bit in its detection.  
 <CECSWAV0 [2:0]>: <CECSWAV1> is for the maximum time of the rising timing. Enables to set it for each sampling clock cycle between the ranges of 0 to +7 cycles from default value (3.9 ms).  
 <CECSWAV0> is for the minimum time of the rising timing. Enables to set it for each sampling clock cycle between the ranges of 0 to -7 cycles from default value (3.5 ms).

**(Note)** Changing the configurations during transmission or reception may harm its proper operation. Before the change, set CECREN <CECREN> to disable the reception and read the <CECREN> bit to ensure that the operation is stopped.

**13.2.9 Receive Control Register 3 [CECR3]**

	23	22	21	20	19	18	17	16
bit Symbol	—	CEC WAV32	CEC WAV31	CEC WAV30	—	CEC WAV22	CEC WAV21	CEC WAV20
Read/Write	R	R/W			R	R/W		
After reset	0	0			0	0		
Function	“0” is read.	The latest rising timing of logical “0” determined as proper waveform. 000: 1.7ms 001: 1.7ms+1cycle 010: 1.7ms+2cycles 011: 1.7ms+3cycles 100: 1.7ms+4cycles 101: 1.7ms+5cycles 110: 1.7ms+6cycles 111: 1.7ms+7cycles			“0” is read.	The fastest rising timing of logical “0” determined as proper waveform. 000: 1.3ms 001: 1.3ms-1cycle 010: 1.3ms-2cycles 011: 1.3ms-3cycles 100: 1.3ms-4cycles 101: 1.3ms-5cycles 110: 1.3ms-6cycles 111: 1.3ms-7cycles		
	15	14	13	12	11	10	9	8
bit Symbol	—	CEC WAV12	CEC WAV11	CEC WAV10	—	CEC WAV02	CEC WAV01	CEC WAV00
Read/Write	R	R/W			R	R/W		
After reset	0	0			0	0		
Function	“0” is read.	The latest rising timing of logical “1” determined as proper waveform. 000: 0.8ms 001: 0.8ms+1cycle 010: 0.8ms+2cycles 011: 0.8ms+3cycles 100: 0.8ms+4cycles 101: 0.8ms+5cycles 110: 0.8ms+6cycles 111: 0.8ms+7cycles			“0” is read.	The fastest rising timing of logical “1” determined as proper waveform. 000: 0.4ms 001: 0.4ms-1cycle 010: 0.4ms-2cycles 111: 0.4ms-3cycles 100: 0.4ms-4cycles 101: 0.4ms-5cycles 110: 0.4ms-6cycles 111: 0.4ms-7cycles		
	7	6	5	4	3	2	1	0
bit Symbol	—							CEC WAVEN
Read/Write	R							R/W
After reset	0							0
Function	“0” is read.							Waveform error detection 1: Enabled 0: Disabled

**(Note) Changing the configurations during transmission or reception may harm its proper operation. Before the change, configure the <CECREN> bits to disable the reception and read the <CECREN> bit to ensure that the operation is stopped.**

- <CECWAV3 [2:0]>: This setting is enabled when the <CECWAVEN> bit is set to "1".  
By setting these bits, an error is detected if rising edge of the received waveform comes later than that of proper logical "0". Enables to set it for each sampling clock cycle between the ranges of 0 to 7 cycles from defined maximum tolerance (1.7 ms). The received waveform is considered to be an error if a rising edge is not detected from the start point of the bit to the value specified in <CECWAV3>.
- <CECWAV2 [2:0]>: This setting is enabled when the <CECWAVEN> bit is set to "1".  
<CECWAV1 [2:0]>: By setting these bits, an error is detected if rising edge of the received waveform comes faster than logical "0" and later than that of proper logical "1".  
Enables to set <CECWAV1> for each sampling clock cycle between the ranges of 0 to 7 cycles from defined maximum tolerance (0.8 ms) of logical "1" waveform.  
Enables to set <CECWAV2> for each sampling clock cycle between the ranges of 0 to -7 cycles from defined minimum tolerance (1.3 ms) of logical "0" waveform.  
The received waveform is considered to be an error if a rising edge is detected between the values specified in <CECWAV2> and <CECWAV1>.
- <CECWAV0 [2:0]>: This setting is enabled when the <CECWAVEN> bit is set to "1".  
By setting these bits, an error is detected if rising edge of the received waveform comes faster than that of proper logical "1". Enables to set <CECWAV0> for each sampling clock cycle between the ranges of 0 to -7 cycles from defined minimum tolerance (0.4 ms).  
The received waveform is considered to be an error if a rising edge is not detected from a start point of the bit to the value specified in <CECWAV0>.
- <CECWAVEN>: Detects a received waveform does not identical to the one defined and generates waveform error interrupt.  
If enabled, an error is detected according to the setting of <CECWAV0> <CECWAV1> <CECWAV2> <CECWAV3>.

**13.2.10 Transmit Enable Register [CECTEN]**

	7	6	5	4	3	2	1	0
bit Symbol	—						CEC TRANS	CECTEN
Read/Write	R						R	W
After reset	0						0	Undefined
Function	"0" is read.						Transmis sion state  0: not in progress 1: in progress	Transmis sion control  0: Disabled 1: Enabled

<CECTRANS>: Indicates whether the transmission is in progress or not. It indicates "1" upon starting the transmission of the start bit. It indicates "0" if transmission is completed or an interrupt is generated. Writing to this bit is ignored.

<CECTEN>: Controls the CEC transmission. Writing this bit enables or disables the transmission. Writing "1" to this bit initiates the transmission. This bit is automatically cleared by a transmit completion interrupt or an error interrupt.

**(Note 1) Set <CECTEN> after setting the transmit buffer register and transmit control register.**

**(Note 2) Stop transmission and reception before changing the settings or enabling the transmission and reception.**

## 13.2.11 Transmit Buffer Register [CECTBUF]

	15	14	13	12	11	10	9	8
bit Symbol	—							CECTEOM
Read/Write	R							R/W
After reset	0							0
Function	"0" is read.							EOM bit
	7	6	5	4	3	2	1	0
bit Symbol	CECTBUF 7	CECTBUF 6	CECTBUF 5	CECTBUF 4	CECTBUF 3	CECTBUF 2	CECTBUF 1	CECTBUF 0
Read/Write	R/W							
After reset	0							
Function	Transmitted data							

<CECTEOM>: Specifies the EOM bit to transmit.

<CECTBUF[7:0]>: Specifies a byte of data to transmit. The bit 7 is the MSB.

**13.2.12 Transmit Control Register [CECTCR]**

	23	22	21	20	19	18	17	16	
bit Symbol	—	CECSTRS 2	CECSTRS 1	CECSTRS 0	—	CECSPRD 2	CECSPRD 1	CECSPRD 0	
Read/Write	R	R/W			R	R/W			
After reset	0	0			0	0			
Function	"0" is read.	Rising timing of start bit 000: Reference value (RV) 001: RV -1cycle 010: RV -2cycle 011: RV -3cycle 100: RV -4cycle 101: RV -5cycle 110: RV -6cycle 111: RV -7cycle			"0" is read.	Start bit cycle 000: RV 001: RV -1cycle 010: RV -2cycle 011: RV -3cycle 100: RV -4cycle 101: RV -5cycle 110: RV -6cycle 111: RV -7cycle			
	15	14	13	12	11	10	9	8	
bit Symbol	—	CECDTRS 2	CECDTRS 1	CECDTRS 0	CECDPRD 3	CECDPRD 2	CECDPRD 1	CECDPRD 0	
Read/Write	R	R/W			R/W				
After reset	0	0			0				
Function	"0" is read.	Rising timing of data bit 000: RV 001: RV -1cycle 010: RV -2cycle 011: RV -3cycle 100: — (Reserved) 101: — (Reserved) 110: — (Reserved) 111: — (Reserved)			Data bit cycle 0000: RV 0001: RV -1cycle 0010: RV -2cycle 0011: RV -3cycle 0100: RV -4cycle 0101: RV -5cycle 0110: RV -6cycle 0111: RV -7cycle				1000: RV -8cycle 1001: RV -9cycle 1010: RV -10cycle 1011: RV -11cycle 1100: RV -12cycle 1101: RV -13cycle 1110: RV -14cycle 1111: RV -15cycle
	7	6	5	4	3	2	1	0	
bit Symbol	—			CECBRD	CECFREE 3	CECFREE 2	CECFREE 1	CECFREE 0	
Read/Write	R			R/W	R/W				
After reset	0			0	0				
Function	"0" is read.			Broadcast transmission 0: No 1: Yes	Time of bus to be free 0000: 1 bit cycle 0001: 2 bit cycle 0010: 3 bit cycle 0011: 4 bit cycle 0100: 5 bit cycle 0101: 6 bit cycle 0110: 7 bit cycle 0111: 8 bit cycle				1000: 9 bit cycle 1001: 10 bit cycle 1010: 11 bit cycle 1011: 12 bit cycle 1100: 13 bit cycle 1101: 14 bit cycle 1110: 15 bit cycle 1111: 16 bit cycle

- <CECSTRS[2:0]>: Specifies the rising timing of a start bit.  
Enables to set it for each sampling clock cycle between the ranges of 0 to -7 cycles from default value (3.7 ms approx.).
- <CECSPRD[2:0]>: Specifies a cycle of a start bit.  
Enables to set it for each sampling clock cycle between the ranges of 0 to -7 cycles from default value (4.5 ms approx.).
- <CECDTRS[2:0]>: Specifies the rising timing of a data bit.  
Enables to set it for each sampling clock cycle between the ranges of 0 to -7 cycles from default value (logical "1": 0.6 ms approx., logical "0": 1.5 ms approx.).
- <CECDPRD[3:0]>: Specifies a cycle of a data bit.  
Enables to set it for each sampling clock cycle between the ranges of 0 to -15 cycles from default value (2.4 ms approx.).
- <CECBRD>: Set this bit to "1" when transmitting a broadcast message.
- <CECFREE[3:0]>: Specifies time of a bus to be free that checked before transmission. Start transmission after checking the CEC line kept inactive during the specified cycles.

<b>(Note)</b> <CECDTRS> must be used under the same setting as CECRCR1<CECLNC>.
---

**13.2.13 Receive Interrupt Status Register [CECRSTAT]**

	7	6	5	4	3	2	1	0
bit Symbol	—	CECRIWAV	CECRIOR	CECRIACK	CECRIMIN	CECRIMAX	CECRISTA	CECRIEND
Read/Write	R	R	R	R	R	R	R	R
After reset	0	0	0	0	0	0	0	0
Function	"0" is read.	Interrupt flag 1: Waveform error	Interrupt flag 1: Receive buffer overrun	Interrupt flag 1: ACK collision	Interrupt flag 1: Min. cycle error	Interrupt flag 1: Max. cycle error	Interrupt flag 1: Start bit detection	Interrupt flag 1: Completion of 1 byte data reception

<CECRIWAV>: Indicates that waveform error is detected. The error occurs when waveform error detection is enabled in CECRCR3 <CECWAVEN>.

<CECRIOR>: Indicates the receive buffer receives next data before reading the data that had already been set.

<CECRIACK>: Indicates "0" is detected after the specified time to output ACK bit "0".

<CECRIMIN>: Indicates one bit cycle is shorter than the minimum cycle error detection time specified in CECRCR1<CECMIN>.

<CECRIMAX>: Indicates one bit cycle is longer than the maximum cycle error detection time specified in CECRCR1<CECMAX>.

<CECRISTA>: Indicates a start bit is detected.

<CECRIEND>: Indicates 1 byte of data reception is completed.

<b>(Note)</b>	<b>Writing to this bit is ignored.</b>
---------------	--

## 13.2.14 Transmit Interrupt Status Register [CECTSTAT]

	7	6	5	4	3	2	1	0
bit Symbol	—			CECTIUR	CECTIACK	CECTIAL	CECTIEND	CECTISTA
Read/Write	R			R	R	R	R	R
After reset	0			0	0	0	0	0
Function	"0" is read.			Interrupt flag 1: Transmit buffer underrun	Interrupt flag 1: ACK error detection	Interrupt flag 1: Arbitration lost occurs	Interrupt flag 1: data transmission is completed	Interrupt flag 1: Start transmission

<CECTIUR>: Indicates next data has not set to the transmission buffer within a byte of data transmission.

<CECTIACK>: Indicates one of the following conditions occurs.

- When logical "0" is not detected in transmission to the specific address.
- When logical "1" is not detected in transmission of a broadcast message .

<CECTIAL>: Indicates "0" is detected while transmitting "1".

<CECTIEND>: Indicates data transmission including the EOM bit is completed.

<CECTISTA>: Indicates 1 byte of data transmission is started.

<b>(Note)</b>	<b>Writing to this bit is ignored.</b>
---------------	--

**13.2.15 CEC Sampling Clock Select Register [CECFSSSEL]**

	7	6	5	4	3	2	1	0
bit Symbol	—							CECCLK
Read/Write	R							R/W
After reset	0							0
Function	"0" is read.							CEC clock 0:Low(fs) 1:TBAOUT

<CECCLK>: CEC sampling clock  
 0: Low-speed clock(fs)  
 1: TBAOUT

Sets the sampling clock for CEC function. Enables to select either low-speed clock(fs) or timer output as of CEC sampling clock. Timer output range is 30KHz to 34KHz by setting TBAOUT.

<b>(Note)</b>	<b>When changing sampling clock by CECFSSSEL register, stop(prohibit) CEC operation by CECEN&lt;CECEN&gt; register once. Then set CECFSSSEL register first prior to other CEC related registers after starting(permitting) the CEC operation again. And also in the case of software reset by CECRESET register, set CECFSSSEL register first prior to other CEC related registers when changing sampling clock.</b>
---------------	--

### 13.3 Operations

#### 13.3.1 Reception

##### 13.3.1.1 Sampling Clock

CEC lines are sampled by a 32.768KHz of low speed clock(fs) or TBxOUT which is output of 16bit Timer/Event counters.

The sampling clock is configurable with the <CECCLK> bits of the CECFSEL register.

##### 13.3.1.2 Basic Operation

If a start bit is detected, a start bit interruption generates. By generating start bit interruption, CECRSTAT<CECRISTA> is set.

If one byte data, EOM bit and ACK bit are received, the received data is stored in CECRBUF register, and a received interruption generates. By generating the received interruption, CECRSTAT<CECRIEND> is set.

In the CECRBUF register, 8bit data, EOM bit and ACK bit are stored. The ACK bit is not generated in the CEC circuit internally. This bit is generated from a observation of CEC signal same as other data.

After one data block is received, receiving operation continues until detecting the last block of data with EOM bit set to "1". Detecting the end of last block, CEC becomes the start bit waiting mode.

Detecting an error during data reception causes an error interrupt, and CEC waits for the next start bit. The received data is discarded.

**(Note)** Be careful about the precautions of chapter 13.1.3 in the operation.

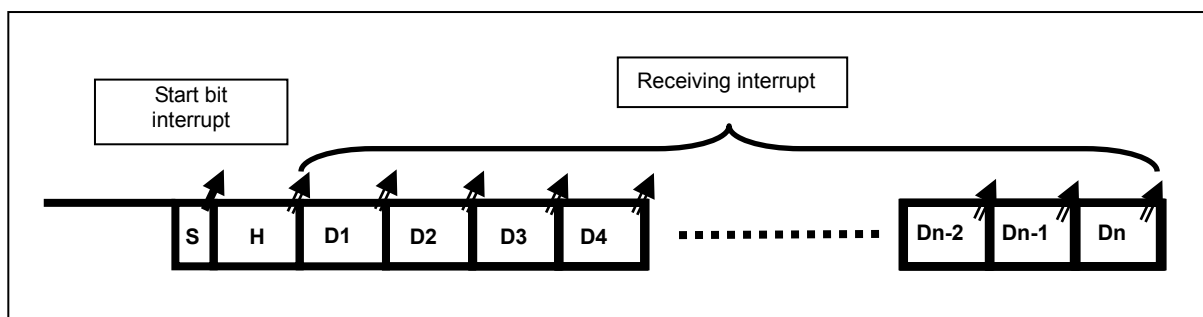

**13.3.1.3 Preconfiguration**

Before receiving data, reception settings to the Logical Address Register <CECADD>, the Receive Control Register 1 <CECR1>, the Receive Control Register 2 <CECR2> and the Receive Control Register 3 <CECR3> are required.

(1) Logical Address Configuration

Configure logical address assigned to this product to the CECADD register. Multiple addresses can be set simultaneously since every bit in this register corresponds with each address.

**(Note) A broadcast message is received regardless of the CECADD register setting. By allocating a logical address of a device to 15, logical "0" is sent as an ACK response to the broadcast message.**

(2) Noise Cancellation Time

The noise cancellation time is configurable with the <CECHNC[1:0]><CECLNC[2:0]> bits of the CECR1 register. You can configure the time to detect "1" and "0" respectively.

It is considered as noise if "1"s or "0"s of the same number as the specified value are not sampled.

A CEC line is monitored at each rising edge of a sampling clock. In the case that the CEC line is changed from "1" to "0", the change is fully recognized if "0"s of the same number as specified in the <CECLNC> bit are monitored. In the case that the CEC line is changed from "0" to "1", the change is fully recognized if "1"s of the same number as specified in the <CECHNC> bit are sampled.

**(Note) <CECLNC> must be used under the same setting as CECTCR<CEDTRS>.**

The following illustrates the operation of a case that a noise cancelling is configured as <CECHNC [1:0]>=10 (3 samplings) and <CECLNC [2:0]>=011 (4 samplings). By cancelling the noise, a signal "1" shifts to "0" after "0" is sampled four times. The signal "0" shifts to "1" after "1" is sampled three times.

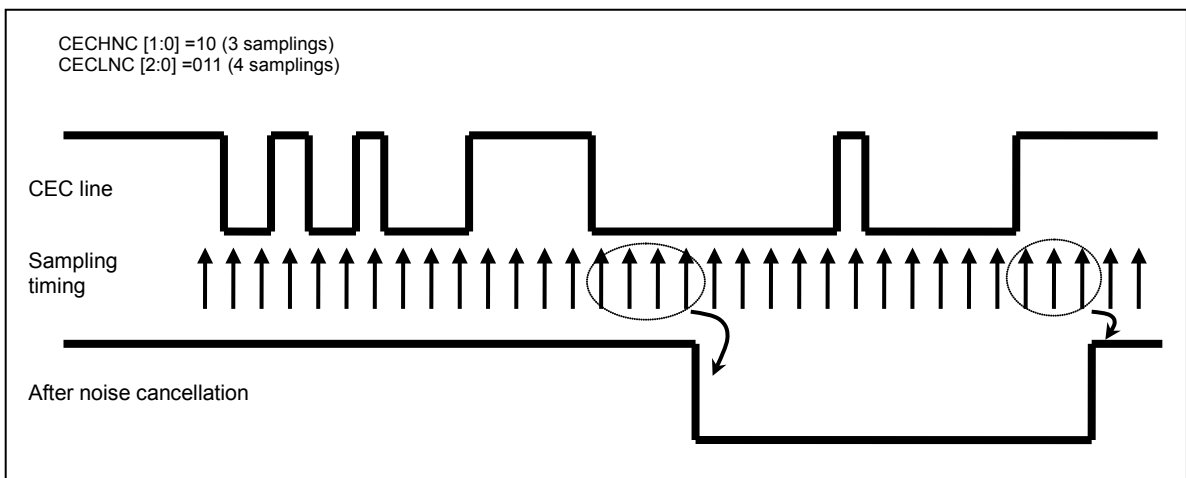

(3) Cycle Error

Configure the CECRCR1 <CECMIN[2:0]> <CECMAX[2:0]> bits to detect a cycle error.

You can specify the time to detect a cycle error for each sampling clock cycle between the ranges of -4 to +3 cycles from the maximum or minimum time set in the CEC standard.

Detecting an error during data reception causes an error interrupt, and CEC waits for the next start bit. The received data is discarded.

(4) Point of Determining Data

Configure the CECRCR1 <CECDAT> bit for the point of determining the data as "0" or "1".

You can specify it per two sampling clock cycles between the ranges of + or - 6 cycles with approx. 1.05 ms from the bit start point.

(5) ACK Response

Configuring the CECRCR1 <CECACKDIS> bit enables you to specify if logical "0" is sent or not as an ACK response to the data block when destination address corresponds with the address set in the logical address register.

The header block sends logical "0" as an ACK response regardless of the bit setting when detecting the addresses corresponding.

(6) Receive Error Interrupt Suspend

Configure the CECRCR1 <CECRIHLD> bit to specify if a receive error interrupt (maximum cycle error, buffer overrun and waveform error) is suspended or not.

Setting "1" generates no interrupt at the error detection. If data continues to the ACK bit, an ACK response is executed by a reversed logic. If the subsequent bits are interrupted, it is determined as a timeout, based on the setting in <CECTOUT> of the CECRCR1 register. After the ACK response or the timeout determination, an interrupt is generated.

(7) Cycles to Identify Timeout

Configure the CECRCR1 <CECTOUT> bit to specify the time to determine a timeout.

This is used when the setting of a receive error interrupt suspension, which is specified in CECRCR1 <CECRIHLD>, is valid.

(8) Data Reception at Logical Address Discrepancy

By setting CECRCR1 <CECOTH>, you can specify if data is received or not when destination address does not correspond with the address set in the logical address register.

In this case, data is received as usual, and an interrupt is generated by detecting an error. However, an ACK response of neither the header block nor the data block is sent.

**(Note 1)** A broadcast message is received regardless of the <CECOTH> register setting.

**(Note 2)** If the initiator sends a new message beginning with the start bit without having sent the last block with EOM="1", a maximum cycle error is determined for the ACK bit and an interrupt is generated. Then, the receive operation is performed in the usual way.

(9) Start Bit Detection

Configuring the CECRCR2 register allows you to specify the rising timing and a cycle of the start bit detection respectively.

<CECSWAV0> is to specify the fastest start bit rising timing. <CECSWAV1> is to specify the latest start bit rising timing ((1) in the figure shown below).

<CECSWAV2> is to specify the minimum cycle of a start bit. <CECSWAV3> is to specify the maximum cycle of a start bit ((2) in the figure shown below).

If a rising edge during the period (1) and a falling edge during the period (2) are detected, the start bit is considered to be valid.

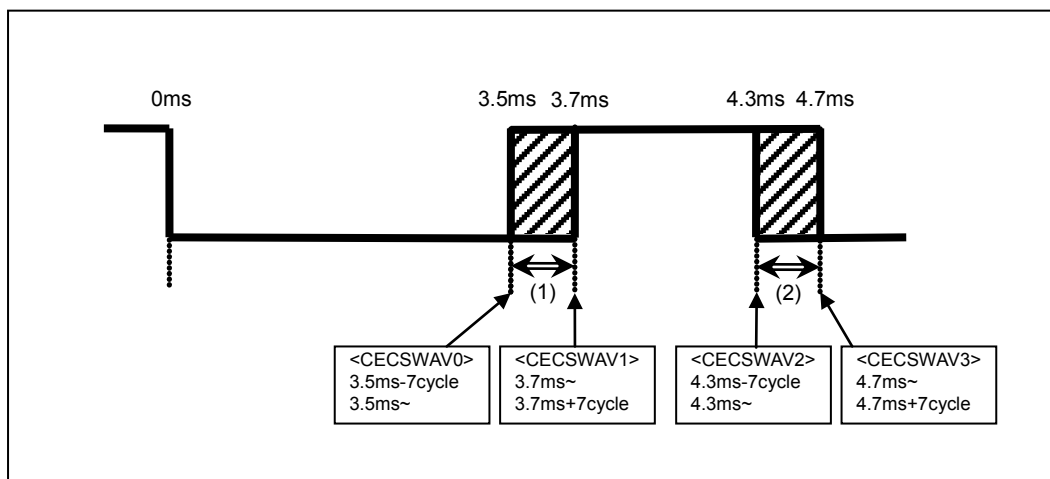

(10) Waveform Error Detection

To detect an error when a received waveform is out of the defined tolerance range, configure the CECRCR3 register.

An error is detected when the <CECWAVEN> bit of the CECRCR3 register is enabled. You can specify the detection time in the <CECWAV0> <CECWAV1> <CECWAV2> <CECWAV3> bits.

If the rising edge is detected during the period (1) or (2) shown below, or not detected in the timing described in (3), a waveform error interrupt is generated.

- (1) A period between the beginning of a bit and the fastest logical "1" rising timing.
- (2) A period between the latest logical "1" rising timing and the fastest logical "0" rising timing.
- (3) The latest logical "0" rising timing.

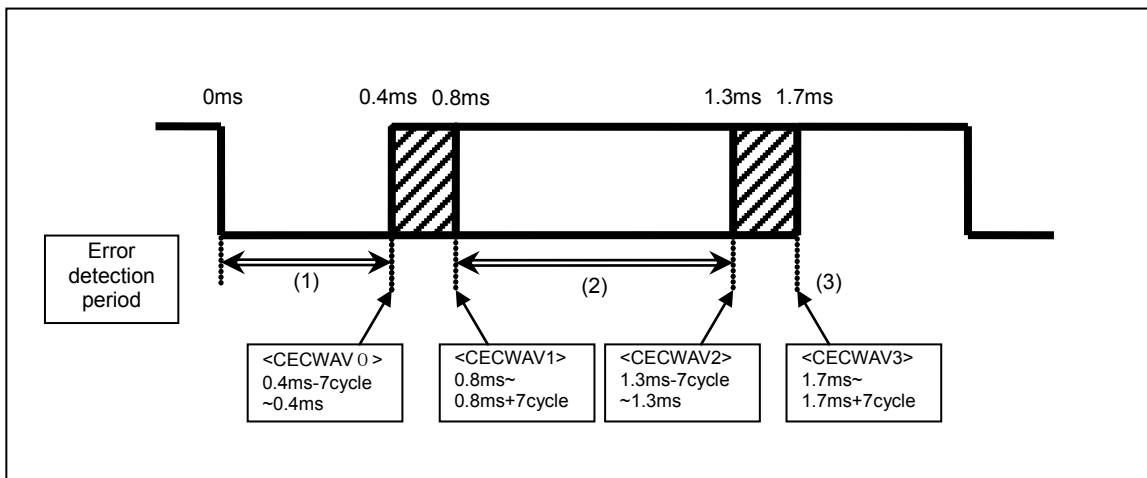

### 13.3.1.4 Enabling Reception

After configuring the CECADD, CECRCR1, CECRCR2 and CECRCR3 registers, CEC is ready for reception by enabling the CECREN <CECREN> bit. Detecting a start bit initiates the reception.

**(Note)** Changing the configurations of the CECADD, CECRCR1, CECRCR2 and CECRCR3 registers during transmission or reception may harm its proper operation. Before the change of the registers shown below, set the CECREN <CECREN> bit to disable the reception and read the <CECREN> bit and the CECTEN <CECTRANS> bit to ensure that the operation is stopped.

<b>CECADD</b>	<b>&lt;CECADD[15:0]&gt;</b>	<b>Logical address</b>
<b>CECRCR1</b>	<b>&lt;CECHNC&gt;&lt;CECLNC&gt;</b>	<b>Noise cancellation time</b>
	<b>&lt;CECMIN&gt;&lt;CECMAX&gt;</b>	<b>Time to identify cycle error</b>
	<b>&lt;CECOTH&gt;</b>	<b>Data reception at logical address discrepancy</b>
<b>CECRCR2</b>	<b>&lt;CECSWAV0&gt;&lt;CECSWAV1&gt; &lt;CECSWAV2&gt;&lt;CECSWAV3&gt;</b>	<b>Start bit detection</b>
<b>CECRCR3</b>	<b>&lt;CECWAV0&gt;&lt;CECWAV1&gt; &lt;CECWAV2&gt;&lt;CECWAV3&gt;</b>	<b>Waveform error detection (when enabled)</b>

### 13.3.1.5 Reception

After detecting a start bit, a start bit interrupt is generated, and the CECRSTAT <CECRISTA> bit is set.

Upon receiving a byte of data, the EOM and ACK bits, they are stored in the CECRBUF register. A receive interrupt is generated and it causes the CECRSTAT <CECRIEND> bit to be set. Same as the other data, the ACK bit that monitored the CEC line is stored instead of the one generated in the CEC circuit.

The reception continues from the first data block until the final data block that has the EOM bit indicating "1". After detecting the final data block, CEC waits for a next start bit.

### 13.3.1.6 Data Sampling Point

The figure shown below illustrates a data sampling timing.

With the CECRCR1 <CECDAT> bit, you can specify a data sampling point per two sampling clock cycles between the ranges of + or - 6 cycles from a reference point (approx. 1.05 ms).

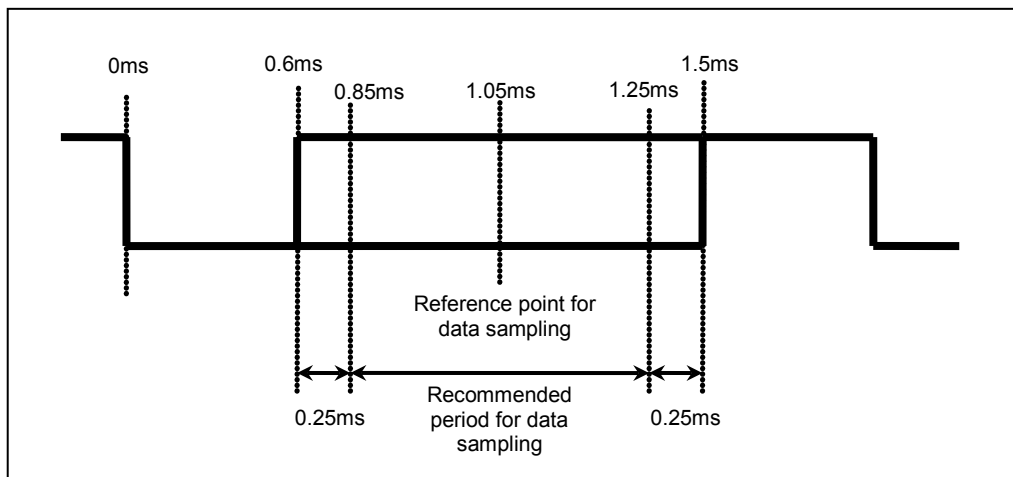

**13.3.1.7 ACK Response**

Setting the CECRCR1 <CECACKDIS> bit enables to specify if logical “0” is sent or not as an ACK response to the data block when destination address corresponds with the address set in the logical address register. The header block sends logical “0” as an ACK response regardless of the bit setting when detecting the addresses corresponding.

The following lists the ACK responses.

“Yes” indicates that CEC outputs “0” as a response to the ACK signal from a transmission device (ACK bit: logical “0”). “No” indicates that CEC does not output “0” as a response to the ACK signal from a transmission device (ACK bit: logical “1”).

Register setting		Header block address		Data block address	
		Conformity	Discrepancy	Conformity	Discrepancy
CECRCR1 <CECACKDIS>	“0” (responding logical “0”)	Yes	No	Yes	No
	“1” (not responding logical “0”)			No	No

The following describes the ACK response timing.

When the falling edge of the ACK bit from the initiator is detected, this IP outputs “0” for approximately 1.526ms. The start time of outputting “0” is specified with CECRCR1<CECLNC> bit that sets the noise cancelling time.

**(Note) <CECLNC> must be used under the same setting as CECTCR<CECDTRS>.**

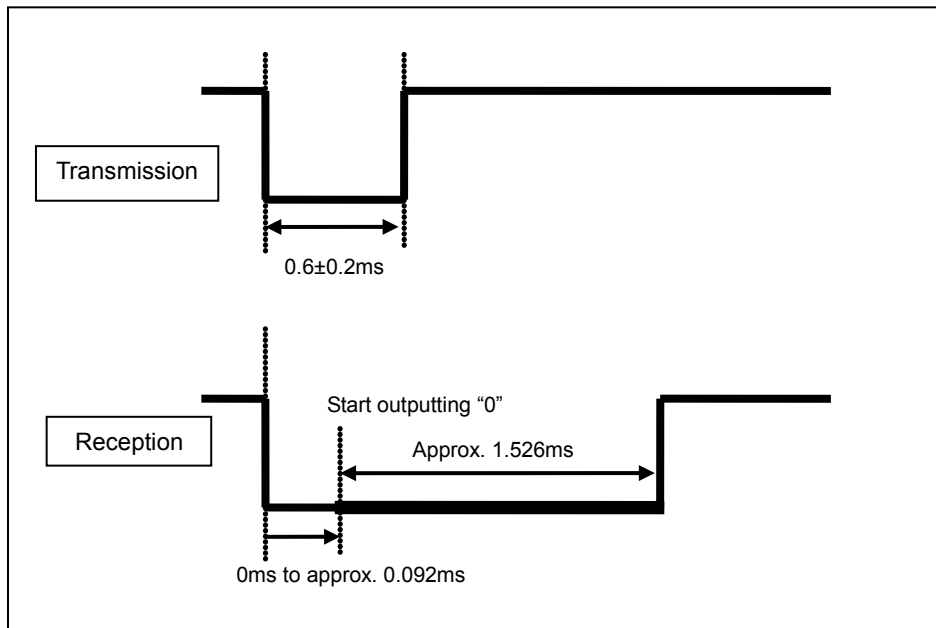

### 13.3.1.8 Detecting Error Interrupt

Detecting an error during data reception causes an error interrupt, and CEC waits for the next start bit. The received data is discarded.

It is possible to suspend a receive error interrupt (maximum cycle error, receive buffer overrun and waveform error), continue reception and send the reversed ACK response.

You can check the interrupt factor by monitoring the bit of the CECRSTAT register corresponding to the interrupt.

### 13.3.1.9 Details of Receive Error

#### (1) Cycle Error

Period between the falling edges of the two sequential bits is measured during reception. If the period does not comply with the specified minimum or maximum value, a cycle error interrupt is generated.

The maximum and minimum cycles are specified in the CECRCR1 <CECMIN[2:0]> <CECMAX[2:0]> bits. A cycle error can be detected for each sampling clock cycle between the ranges of -4 to +3 cycles from the minimum value (approx. 2.045 ms) or the maximum value (approx. 2.747 ms) defined by the CEC standard.

The CECRSTAT <CECRIMIN> bit or the <CECRIMAX> bit is set if a cycle error interrupt is generated.

The minimum cycle error causes CEC to output "0" for approx. 3.63 ms.

**(Note 1) When minimum cycle error is detected, "0" is output after "0" detecting noise cancellation time.**

**(Note 2) If the initiator sends a new message beginning with the start bit without having sent the last block with EOM="1", a maximum cycle error may be determined for the ACK bit. For detail, refer to the Chapter13.1.3.**

#### (2) ACK Collision

At an ACK response, detecting "0" after the specified period to output generates an ACK collision interrupt or a minimum cycle error interrupt.

The ACK collision interrupt sets the CECRSTAT <CECRIACK> bit. The minimum cycle error interrupt sets the CECRSTAT <CECRIMIN> bit.

The following describes the period and method of detection.

Detection starts approx. 0.3 ms after the end of the period of outputting "0" and ends approx 2.0 ms from the starting point (the falling edge) of the ACK bit.

At 0.3 ms from the end of the period of outputting "0", CEC checks if the CEC line is "0" or not. If it is "0", an ACK collision interrupt is generated. If it is "1", and "0" is detected during the detection period, the minimum cycle error interrupt is generated. The minimum cycle error causes CEC to output "0" for approx. 3.6 ms.

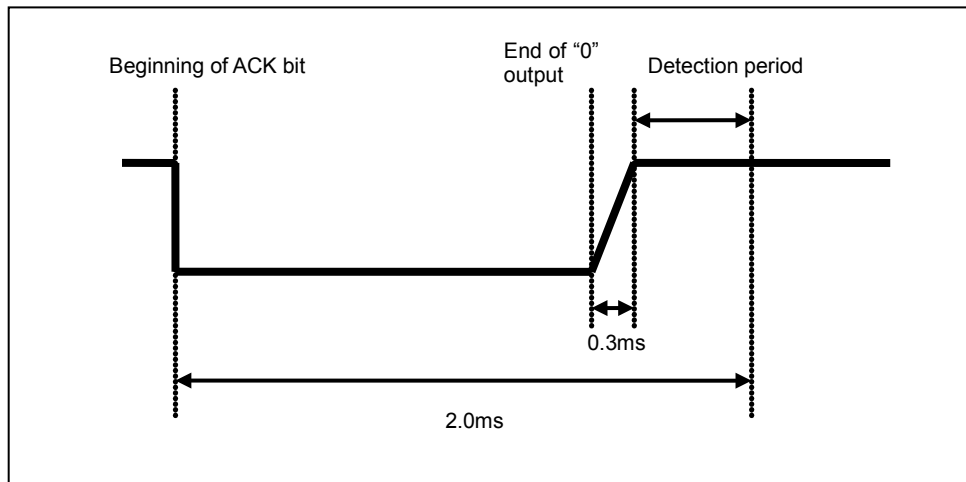

### (3) Receive Buffer Overrun

A receive buffer overrun interrupt is generated when the next data reception is completed before reading the data stored in the receive buffer.

The interrupt sets the CECRSTAT <CECRIOR> bit.

### (4) Waveform Error

A waveform error occurs when waveform error detection is enabled in CECR3. Detecting a waveform, which does not identical to the defined, results in the waveform error. The interrupt is generated.

The interrupt sets the CECRSTAT <CECRIWAV> bit.

### (5) Suspending Receive Error Interrupt

You can specify if a maximum cycle error, a buffer overrun and a waveform error are suspended or not without generating an interrupt at error detection. This can be set in the CECR1 <CECRIHLD> bit. To enable the setting, a timeout setting with the CECR1 <CECTOUT> bit is required.

Under suspend-enable condition, if CEC keeps receiving the next bit and the entire reception including the ACK bit is completed, CEC generates an interrupt after a reversed ACK response is executed. "1" is set to the bits of the CECRSTAT register: the <CECRIEND> bit that indicates the reception completion, and the bits corresponding to the detected errors.

If the reception of the next bit is interrupted, CEC starts to measure the timeout period, and an interrupt is generated after the timeout. "1" is set to the bits of the CECRSTAT register corresponding to the detected error.

The timeout is measured from the end of the last bit received as is the case with wait time of a bus to be free in transmission.

The information that the interrupts are suspended is held until the EOM bit is received or the timeout occurs. Thus, an interrupt is generated in each reception of a byte of data if multiple bytes are received while interrupts are suspended. "1" is set to the bits of the CECRSTAT register: the <CECRIEND> bit that indicates the reception completion, and the bits corresponding to the detected errors. The flags of the suspended interrupts and the reception completion are set to the bits of the CECRSTAT register.

- (Note 1)** A minimum cycle error interrupt is generated upon detecting a minimum cycle error in the next received bit while interrupts are suspended. "0" is output to CEC for approx. 3.6 ms.  
The flags of the suspended interrupts and the minimum cycle error are set to the bits of the CECRSTAT register.
- (Note 2)** If an interrupt other than a minimum cycle error interrupt is generated while interrupts are suspended, CEC continues reception until the ACK response or the timeout.  
All the flags of the detected interrupts are set to the bits of the CECRSTAT register.

#### 13.3.1.10 Stopping Reception

Writing "0" to the CECREN <CECREN> bit disables data reception. The reception is stopped upon disabling the bit during reception. The received data is discarded.

- (Note)** If the reception is disabled while "0" is sent as a signal of minimum cycle error, the "0" output is stopped as well.

### 13.3.2 Transmission

#### 13.3.2.1 Basic Operation

Configure a start bit of transmission after configuring the data buffer. It enables the start bit to be transmitted after time that a bus is free is properly maintained.

Transmitting the first data bit subsequent to the start bit generates a transfer interrupt. It indicates that the next data can be set to a transmit buffer. The ACK bit is sent after a byte of data (8 bit) and the EOM bit are transmitted, and then the ACK response is detected.

The data transmission per byte continues until the data including the EOM bit that indicates "1" is stored in the transmit buffer. If its transmission is completed, a transmit completion interrupt is generated.

If an error is generated during transmission, an error interrupt is generated to stop transmission. Even if reception is enabled, no reception is executed during transmission.

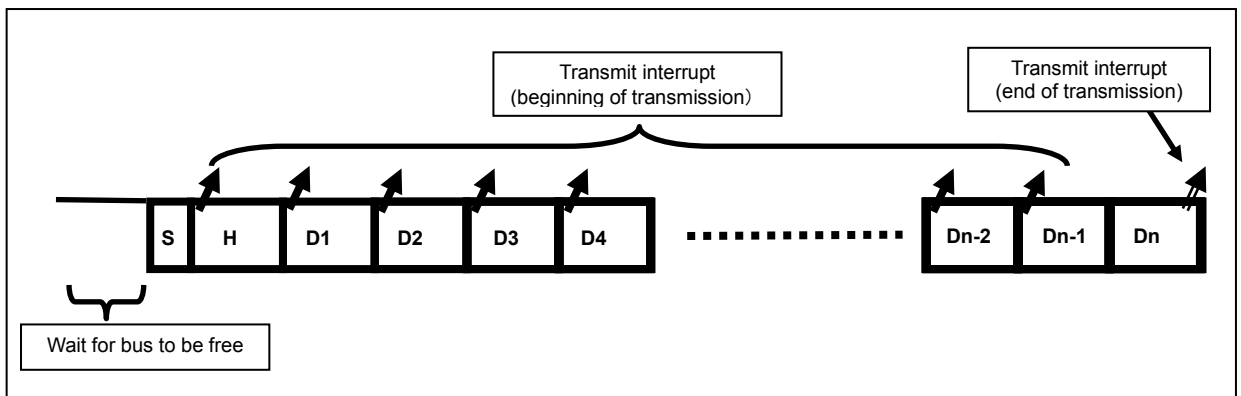

### 13.3.2.2 Preconfiguration

Before transmitting data, transmission settings to the Transmit Control Register CECTCR>and the transmit buffer <CECTBUF> are required.

#### (1) Bus Free Wait Time

Specify the bus free wait time in the CECTCR<CECFREE> bits. It can be specified in a range of 1 to 16 bit cycles.

Counting of the bus free wait time begins one bit cycle after the falling edge of the final bit. If the signal stays high for the specified number of bit cycles, transmission starts.

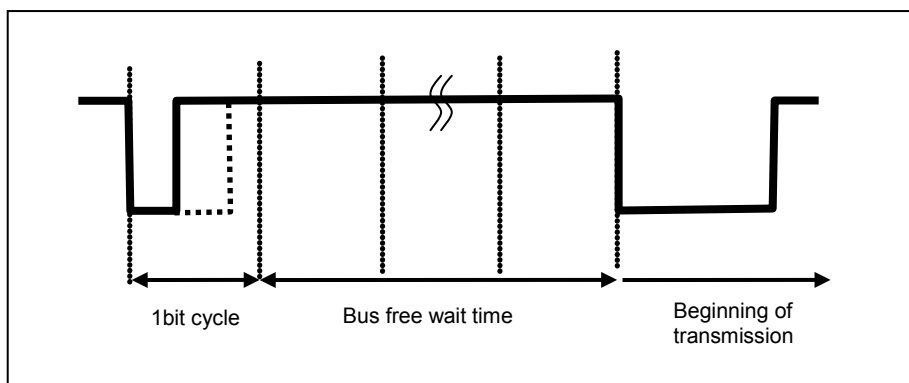

#### (2) Transmitting Broadcast Message

Set the CECTCR <CECBRD> bit when transmitting a broadcast message. If this bit is set, “0” response during an ACK cycle results in an error. If not, “1” response during an ACK cycle results in an error.

#### (3) Adjusting Transmission Waveform

Both start bit and data bit are capable of adjusting the rising timing and cycle. With the CECTCR <CECSTRS> <CECSPRD> <CECDTRS> <CECDPRD> bits, the timing can be specified between the defined fastest rising/cycle timing and the reference value.

The following figures show how the waveforms differ according to the configurations of the start bit, logical “0” and logical “1”.

(Note) The configuration of <CECDTRS> is applied for waveform of an ACK response during reception. The ACK response and the logical “0” output show the same waveform.

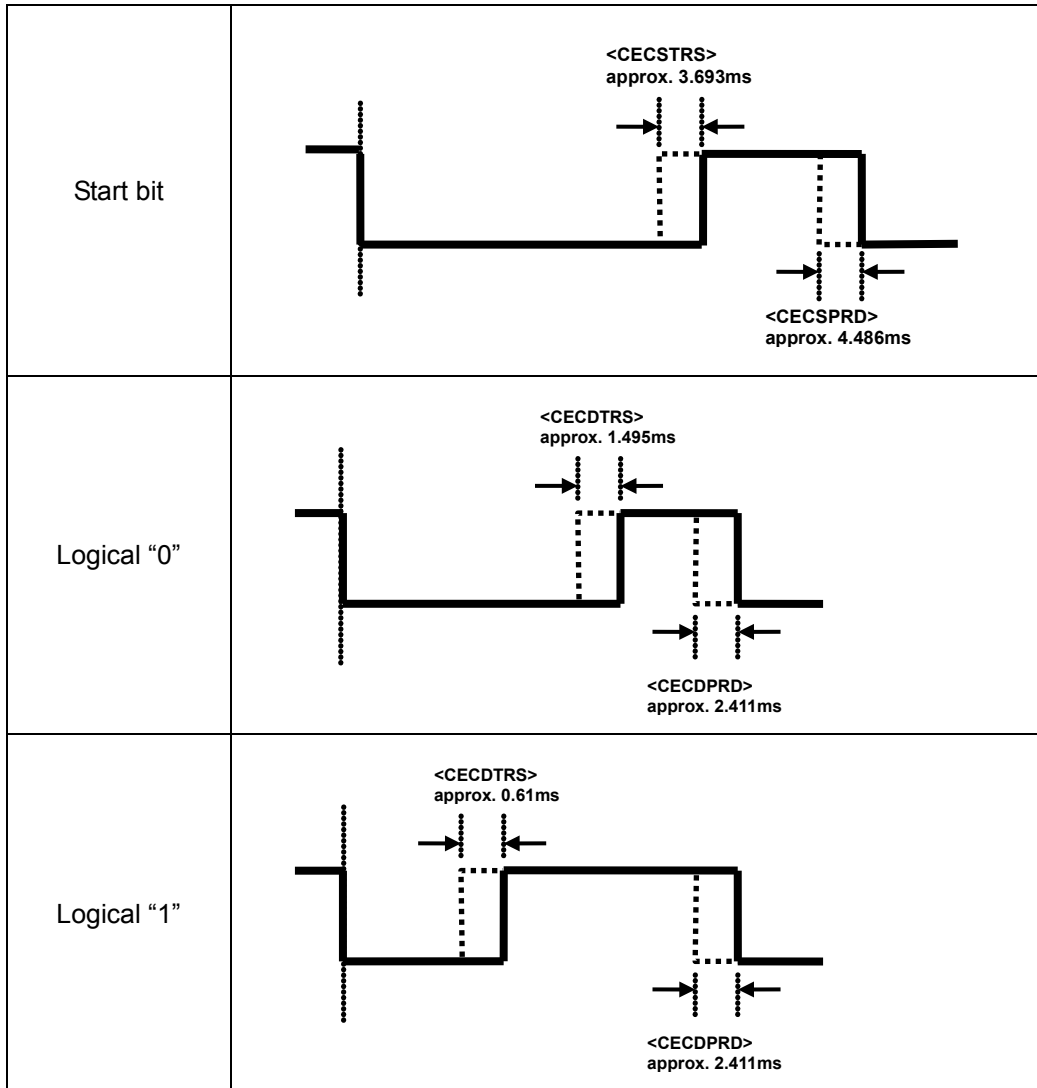

(4) Preparing Transmission Data

Configure a byte of transmission data and EOM data with the CECTBUF register.

### 13.3.2.3 Starting Transmission

Transmission is ready by setting the CECTEN <CECTEN> bit to start transmission after setting the CECTCR and CECTBUF registers.

The <CECTEN> bit is never cleared to "0" until a transmit completion interrupt or an error interrupt occurs. Thus you don't need to set this bit for each a byte of data transmission.

**(Note) Changing the configurations of the CECTCR register during transmission or reception may harm its proper operation. Be careful if you change it during transmission.**

### 13.3.2.4 Transmission

Next to the setting for starting transmission, CEC checks if a bus is free. If "1" is sampled as a CEC line for specified bit cycles, start bit is transmitted. The CEC always checks if bus is free. Transmission starts anytime if bus is free for specified bit cycles.

After transmitting a start bit, a byte of data and the EOM data that are set in the buffer are sent to the shift register, and data transmission is started. When CEC starts transmitting the first bit of a byte of data, a transmit interrupt is generated. It sets the CECTSTAT <CECTISTA> bit. Subsequent to the transmit interrupt, a byte of next data can be set to the transmit buffer.

Then 8 bit data, the EOM bit and the ACK bit are transmitted, and the ACK response is checked. This is the end of a byte of data transmission.

Data transfer continues in the above sequence until "1" is set to the EOM bit.

If "1" is set to the EOM, a transmit completion interrupt is generated subsequent to the ACK bit check as described above. Generation of this interrupt, which means the end of a sequence of transmission operation, sets the CECTSTAT <CECTIEND> bit, and clears the CECTEN <CECTEN> bit.

### 13.3.2.5 ACK Transmission and ACK Error Criterion

A criterion of the ACK error differs depending on the CECTCR <CECBRD> bit.

If this bit is set, broadcast message is transmitted, and the ACK response of logical "0" is determined as an error. If this bit is not set, the ACK response of logical "1" is determined as an error.

**13.3.2.6 Detecting Transmission Error**

Error detection during transmission generates an interrupt and stops transmission. It clears the CECTEN <CECTEN> bit.

To identify an error factor, the CECTSTAT register has bits that correspond with each interrupt. You can identify the interrupt factor by checking these bits.

**(Note)** An attempt to stop transmission by an error may cause an improper waveform output to CEC. This is because output is stopped immediately after the error occurs.

**13.3.2.7 Details of Transmission Error**

(1) Arbitration Lost

An arbitration lost error occurs when CEC detects “0” on completion of appropriate low duration.

Detecting an arbitration lost error sets the CECTSTAT <CECTIAL> bit.

Two types of the arbitration lost detection periods are shown below.

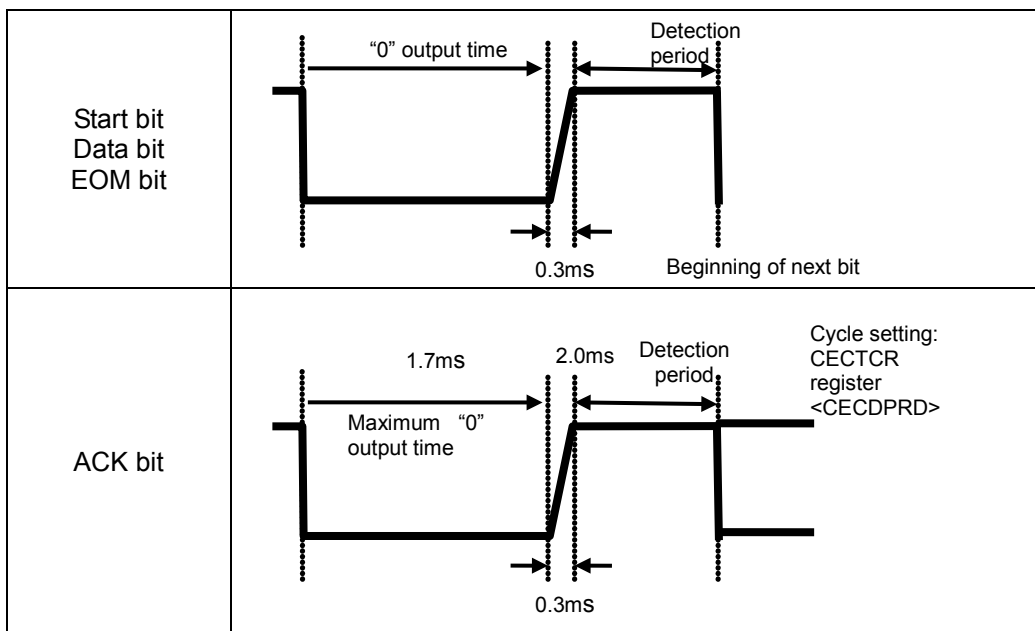

## (2) ACK error

An ACK error interrupt occurs when an ACK response does not conform to the configuration specified in the CECTCR <CECBRD> bit.

When the ACK error interrupt occurs, the CECTSTAT <CECTIACK> bit is set.

The ACK error is detected in the following cases.

Configuration	Determined as an ACK error when
<CECBRD>=0 Broadcast transmission?: No	ACK response is logical "1"
<CECBRD>=1 Broadcast transmission?: Yes	ACK response is logical "0"

## (3) Transmit Buffer Under run

A transmit buffer under run error is caused by the following sequence.

1. Data in the transmit buffer is transmit to the shift register.
2. An interrupt occurs.
3. A byte of data is transmitted.
4. No data is set to the transmit buffer before starting transmission of a byte of subsequent data.

When an under run error occurs, the CECTSTAT <CECTIUR> bit is set.

## (4) Order of ACK Error and Transmit Buffer Overrun

If interrupt factors of the ACK error and transmit buffer under run are detected at the end of transmission of a byte of data, the transmit buffer under run has priority. The transmit buffer under run interrupt occurs first and then the ACK error interrupt occurs.

**13.3.2.8 Stopping Transmission**

To stop transmission, send data including the EOM bit that indicates "1". This generates a transmit completion interrupt.

Please note that proper operation is not ensured if the start bit of transmission is set to "0" during transmission.

**13.3.2.9 Retransmission**

Transmission is stopped by error detection. To retry the transmission, configure the condition and data of starting the transmission.

### 13.3.3 Software Reset

The entire CEC function can be initialized by software.

Setting “1” to the software reset register CECRESET <CECRESET> bit causes the following operations.

- Reception : Immediately stops. The received data is discarded.
- Transmission : Immediately stops including output to the CEC line.
- Register : All the registers other than CECEN are initialized.

Please note that software reset during transmission may cause the CEC line waveform that does not identical to the defined.

## 14 Remote control signal preprocessor (RMC)

### 14.1 Basic operation

Remote control signal preprocessor (hereafter referred to as RMC) receives a remote control signal of which carrier is removed.

#### 14.1.1 Reception of Remote Control Signal

- Sampled by 32KHz clock
- Noise canceller
- Leader detection
- Batch reception up to 72bit of data

## 14.2 Registers

### 14.2.1 Register Map

Addresses and names of RMC control registers are shown below.

Register		Address	
		Channel 0	Channel 1
Remote Control Enable Register	RMCxEN	0x4004_0400	0x4004_0440
Remote Control Receive Enable Register	RMCxREN	0x4004_0404	0x4004_0444
Remote Control Receive Data Buffer Register 1	RMCxRBUF1	0x4004_0408	0x4004_0448
Remote Control Receive Data Buffer Register 2	RMCxRBUF2	0x4004_040C	0x4004_044C
Remote Control Receive Data Buffer Register 3	RMCxRBUF3	0x4004_0410	0x4004_0450
Remote Control Receive Control Register 1	RMCxRCR1	0x4004_0414	0x4004_0454
Remote Control Receive Control Register 2	RMCxRCR2	0x4004_0418	0x4004_0458
Remote Control Receive Control Register 3	RMCxRCR3	0x4004_041C	0x4004_045C
Remote Control Receive Control Register 4	RMCxRCR4	0x4004_0420	0x4004_0460
Remote Control Receive Status Register	RMCxRSTAT	0x4004_0424	0x4004_0464

### 14.2.2 Remote Control Enable Register [RMCEN]

	7	6	5	4	3	2	1	0	
bit Symbol	—							—	RMCEN
Read/Write	R							R/W	R/W
After reset	0							0	0
Function	"0" is read.							Write as "1".	RMC operation 0: Disabled 1: Enabled

<RMCEN>: Controls RMC operation.

To allow RMC to function, enable the RMCEN bit first. If the operation is disabled, all the clocks for RMC except for the enable register are stopped, and it can reduce power consumption.

If RMC is enabled and then disabled, the settings in each register remain intact.

### 14.2.3 Remote Control Receive Enable Register [RMCREN]

	7	6	5	4	3	2	1	0	
bit Symbol	—							—	RMCREN
Read/Write	R							R/W	R/W
After reset	0							0	0
Function	"0" is read.							Reception	0: Disabled 1: Enabled

<RMCREN>: Controls reception of RMC.

Setting this bit to "1" enables reception.

**(Note) Enable the <RMCREN> bit after setting the RMCxRCR1, RMCxRCR2 and RMCxRCR3.**

#### 14.2.4 Remote Control Receive Data Buffer Register 1 [RMCRBUF1]

	31	30	29	28	27	26	25	24
bit Symbol	RMCRBUF 31	RMCRBUF 30	RMCRBUF 29	RMCRBUF 28	RMCRBUF 27	RMCRBUF 26	RMCRBUF 25	RMCRBUF 24
Read/Write	R							
After reset	0							
Function	Received data							
	23	22	21	20	19	18	17	16
bit Symbol	RMCRBUF 23	RMCRBUF 22	RMCRBUF 21	RMCRBUF 20	RMCRBUF 19	RMCRBUF 18	RMCRBUF 17	RMCRBUF 16
Read/Write	R							
After reset	0							
Function	Received data							
	15	14	13	12	11	10	9	8
bit Symbol	RMCRBUF 15	RMCRBUF 14	RMCRBUF 13	RMCRBUF 12	RMCRBUF 11	RMCRBUF 10	RMCRBUF 9	RMCRBUF 8
Read/Write	R							
After reset	0							
Function	Received data							
	7	6	5	4	3	2	1	0
bit Symbol	RMCRBUF 7	RMCRBUF 6	RMCRBUF 5	RMCRBUF 4	RMCRBUF 3	RMCRBUF 2	RMCRBUF 1	RMCRBUF 0
Read/Write	R							
After reset	0							
Function	Received data							

<RMCRBUF[31:0]>: Reads 4 bytes of received data.

### 14.2.5 Remote Control Receive Data Buffer Register 2 [RMCRBUF2]

	31	30	29	28	27	26	25	24
bit Symbol	RMCRBUF 63	RMCRBUF 62	RMCRBUF 61	RMCRBUF 60	RMCRBUF 59	RMCRBUF 58	RMCRBUF 57	RMCRBUF 56
Read/Write	R							
After reset	0							
Function	Received data							
	23	22	21	20	19	18	17	16
bit Symbol	RMCRBUF 55	RMCRBUF 54	RMCRBUF 53	RMCRBUF 54	RMCRBUF 53	RMCRBUF 52	RMCRBUF 51	RMCRBUF 50
Read/Write	R							
After reset	0							
Function	Received data							
	15	14	13	12	11	10	9	8
bit Symbol	RMCRBUF 47	RMCRBUF 46	RMCRBUF 45	RMCRBUF 44	RMCRBUF 43	RMCRBUF 42	RMCRBUF 41	RMCRBUF 40
Read/Write	R							
After reset	0							
Function	Received data							
	7	6	5	4	3	2	1	0
bit Symbol	RMCRBUF 39	RMCRBUF 38	RMCRBUF 37	RMCRBUF 36	RMCRBUF 35	RMCRBUF 34	RMCRBUF 33	RMCRBUF 32
Read/Write	R							
After reset	0							
Function	Received data							

<RMCRBUF[63:32]>: Reads 4 bytes of received data.

### 14.2.6 Remote Control Receive Data Buffer Register 3 [RMCRBUF3]

	7	6	5	4	3	2	1	0
bit Symbol	RMCRBUF 71	RMCRBUF 70	RMCRBUF 69	RMCRBUF 68	RMCRBUF 67	RMCRBUF 66	RMCRBUF 65	RMCRBUF 64
Read/Write	R							
After reset	0							
Function	Received data							

<RMCRBUF[71:64]>: Reads a byte of received data.

- |          |   |
|----------|---|
| (Note 1) | Received data is stored from RMCRBUF1 <RMCRBUF0> to RMCRBUF3 <RMCRBUF71> in sequence.   |
| (Note 2) | The first received bit is stored in the MSB. The last received bit is stored in the LSB (bit 0).<br>If the remote control signal is received in the LSB first algorithm, the received data is stored in reverse sequence. |

### 14.2.7 Remote Control Receive Control Register 1 [RMCRCR1]

	31	30	29	28	27	26	25	24
bit Symbol	RMCLC MAX7	RMCLC MAX6	RMCLC MAX5	RMCLC MAX4	RMCLC MAX3	RMCLC MAX2	RMCLC MAX1	RMCLC MAX0
Read/Write	R/W							
After reset	0							
Function	Maximum cycle of leader detection: $RMCLC_{MAX} \times 4 / fs[s]$							
	23	22	21	20	19	18	17	16
bit Symbol	RMCLC MIN7	RMCLC MIN6	RMCLC MIN5	RMCLC MIN4	RMCLC MIN3	RMCLC MIN2	RMCLC MIN1	RMCLC MIN0
Read/Write	R/W							
After reset	0							
Function	Minimum cycle of leader detection: $RMCLC_{MIN} \times 4 / fs[s]$							
	15	14	13	12	11	10	9	8
bit Symbol	RMCLL MAX7	RMCLL MAX6	RMCLL MAX5	RMCLL MAX4	RMCLL MAX3	RMCLL MAX2	RMCLL MAX1	RMCLL MAX0
Read/Write	R/W							
After reset	0							
Function	Maximum low width of leader detection: $RMCLL_{MAX} \times 4 / fs[s]$							
	7	6	5	4	3	2	1	0
bit Symbol	RMCLL MIN7	RMCLL MIN6	RMCLL MIN5	RMCLL MIN4	RMCLL MIN3	RMCLL MIN2	RMCLL MIN1	RMCLL MIN0
Read/Write	R/W							
After reset	0							
Function	Minimum low width of leader detection: $RMCLL_{MIN} \times 4 / fs[s]$							

- <RMCLCMAX[7:0]>: Specifies a maximum cycle of leader detection.  
Calculating formula of the maximum cycle:  $RMCLC_{MAX} \times 4 / fs[s]$ .  
RMC detects the first cycle as a leader if it is within the maximum cycle.
- <RMCLCMIN[7:0]>: Specifies a minimum cycle of leader detection.  
Calculating formula of the minimum cycle:  $RMCLC_{MIN} \times 4 / fs[s]$ .  
RMC detects the first cycle as a leader if it exceeds the minimum cycle.
- <RMCLLMAX[7:0]>: Specifies a maximum low width of leader detection.  
Calculating formula of the maximum low width:  $RMCLL_{MAX} \times 4 / fs[s]$   
RMC detects the first cycle as a leader if its low width is within the maximum low width.
- <RMCLLMIN[7:0]>: Specifies a minimum low width of leader detection.  
Calculating formula of the minimum low width:  $RMCLL_{MIN} \times 4 / fs[s]$   
RMC detects the first cycle as a leader if its low width exceeds the minimum low width.  
If  $RMCRCR2<RMCLD> = 1$ , a value less than the specified is determined as data.

**(Note)**

When you configure the register, you must follow the rule shown below.

Leader	Rules
Low width + high width	<RMCLCMAX[7:0]> > <RMCLCMIN[7:0]> <RMCLLMAX[7:0]> > <RMCLLMIN[7:0]> <RMCLCMIN[7:0]> > <RMCLLMAX[7:0]>
Only with high width	<RMCLCMAX[7:0]> > <RMCLCMIN[7:0]> <RMCLLMAX[7:0]> = 0x00000000 <RMCLLMIN[7:0]> = don't care
No leader	<RMCLCMAX[7:0]> = 0x00000000 <RMCLCMIN[7:0]> = don't care <RMCLLMAX[7:0]> = don't care <RMCLLMIN[7:0]> = don't care

### 14.2.8 Remote Control Receive Control Register 2 [RMCR2]

	31	30	29	28	27	26	25	24
bit Symbol	RMCLIEN	RMCEDIEN	—	—	—	—	RMCLD	RMCPHM
Read/Write	R/W	R/W	R				R/W	R/W
After reset	0	0	0				0	0
Function	Leader detection interrupt 0: Not generated 1: Generated	Remote control input falling edge interrupt 0: Not generated 1: Generated	"0" is read.				Receiving remote control signal with or without leader 0: Disabled 1: Enabled	Receive a remote control signal in phase method? 0: No (receive in cycle method) 1: Yes
	23	22	21	20	19	18	17	16
bit Symbol	—	—	—	—	—	—	—	—
Read/Write	R							
After reset	0							
Function	"0" is read.							
	15	14	13	12	11	10	9	8
bit Symbol	RMCLL7	RMCLL6	RMCLL5	RMCLL4	RMCLL3	RMCLL2	RMCLL1	RMCLL0
Read/Write	R/W							
After reset	1							
Function	Excess low width that triggers reception completion and interrupt generation 00000000~11111110: $RMCLL \times 1/fs[s]$ 11111111: not to use as the trigger							
	7	6	5	4	3	2	1	0
bit Symbol	RMCDMA X7	RMCDMA X6	RMCDMA X5	RMCDMA X4	RMCDMA X3	RMCDMA X2	RMCDMA X1	RMCDMA X0
Read/Write	R/W							
After reset	1							
Function	Maximum data bit cycle that triggers reception completion and interrupt generation 00000000~11111110: $RMCDMAX \times 1/fs[s]$ 11111111: not to use as the trigger							

<RMCLIEN>: Enables to generate a leader detection interrupt by detecting a leader.

<RMCEDIEN>: Enables to generate a remote control input falling edge Interrupt.

<RMCLD>: Enables RMC to receive signals with or without a leader.

<RMCPHM>: Specifies data reception mode of a phase method. If you use the phase method of which signal cycle is fixed, set "1".

<RMCLL[7:0]>: Specifies an excess low width. If an excess low width is detected, reception is completed and an interrupt is generated. The low width is not detected if <RMCLL[7:0]> = 1111111b. Calculating formula of an excess low width:  $RMCLL \times 1/fs[s]$ .

<RMCDMAX[7:0]>: Specifies a threshold for detecting a maximum data bit cycle. It is detected when a data bit cycle exceeds the threshold. It is not detected when <RMCDMAX[7:0]> = 1111111b. Calculating formula of the threshold:  $RMCDMAX \times 1/fs[s]$ .

## 14.2.9 Remote Control Receive Control Register 3 [RMCR3]

	15	14	13	12	11	10	9	8
bit Symbol	—	RMCDAT H6	RMCDAT H5	RMCDAT H4	RMCDAT H3	RMCDAT H2	RMCDAT H1	RMCDAT H0
Read/Write	R	R/W						
After reset	0	0						
Function	"0" is read.	Larger threshold to determine a signal pattern in a phase method $RMCDATH \times 1/fs[s]$						
	7	6	5	4	3	2	1	0
bit Symbol	—	RMCDAT L6	RMCDAT L5	RMCDAT L4	RMCDAT L3	RMCDAT L2	RMCDAT L1	RMCDAT L0
Read/Write	R	R/W						
After reset	0	0						
Function	"0" is read.	Threshold to determine 0 or 1/ smaller threshold to determine a signal pattern in a phase method $RMCDATL \times 1/fs[s]$						

<RMCDATH[6:0]>: Specifies a larger threshold (within a range of 1.5T and 2T) to determine a pattern of remote control signal in a phase method. If the measured cycle exceeds the threshold, the bit is determined as "10". If not, the bit is determined as "01". Calculating formula of the threshold:  $RMCDATH \times 1/fs[s]$ .

<RMCDATL[6:0]>: Specifies two kinds of thresholds: a threshold to determine whether a data bit is 0 or 1; a smaller threshold (within a range of 1T and 1.5T) to determine a pattern of remote control signal in a phase method. As for the determination of data bit, if the measured cycle exceeds the threshold, the bit is determined as "1". If not, the bit is determined as "0". Calculating formula of the threshold:  $RMCDATL \times 1/fs[s]$ . As for the determination of a remote control signal pattern in a phase method, if the measured cycle exceeds the threshold, the bit is determined as "01". If not, the bit is determined as "00". Calculating formula of the threshold to determine 0 or 1:  $RMCDATL \times 1/fs[s]$ .

**(Note)** If the <RMCPHM> bit of the Remote Control Receive Control Register 2 is "0", <RMCDATH[6:0]> are not enabled. The bits are enabled when <RMCPHM> is "1".

**14.2.10 Remote Control Receive Control Register 4 [RMCR4]**

	7	6	5	4	3	2	1	0
bit Symbol	RMCP0	—	—	—	RMCNC 3	RMCNC 2	RMCNC 1	RMCNC 0
Read/Write	R/W	R			R/W			
After reset	0	0			0			
Function	Remote control input signal 0: Not reversed 1: Reversed	"0" is read.			Noise cancellation time 0000: No cancellation 0001~1111:RMCNC×1/fs[s]			

<RMCP0>: Specifies whether a remote control input signal is reversed or not.

<RMCNC[3:0]>: Specifies time noises are cancelled by a noise canceller. If <RMCNC[3:0]> = 0000b, noises are not cancelled. Calculating formula of noise cancellation time: RMCNC x 1/fs[s].

## 14.2.11 Remote Control Receive Status Register [RMCRSTAT]

	15	14	13	12	11	10	9	8
bit Symbol	RMCLIF	RMCLIF	RMCDMAXIF	RMCEDIF	—	—	—	—
Read/Write	R	R	R	R	R			
After reset	0	0	0	0	0			
Function	Leader detection is interrupt factor? 0: No 1: Yes	Low width detection is interrupt factor? 0: No 1: Yes	Maximum data bit cycle detection is interrupt factor? 0: No 1: Yes	Remote control input falling edge interrupt is interrupt factor? 0: No 1: Yes	"0" is read.			
	7	6	5	4	3	2	1	0
bit Symbol	RMCLDR	RMCRNUM6	RMCRNUM5	RMCRNUM4	RMCRNUM3	RMCRNUM2	RMCRNUM1	RMCRNUM0
Read/Write	R	R						
After reset	0	0						
Function	Leader detection 0: No 1: Yes	The number of received data bit 0000000:no data bit (only with leader) 0000001~1001000:1~72bit 1001001~1111111:73bit and more						

<RMCLIF>: Indicates that leader detection is the interrupt factor.

<RMCLIF>: Indicates that low width detection is the interrupt factor.

<RMCDMAXIF>: Indicates that maximum data bit cycle detection is the interrupt factor.

<RMCEDIF>: Indicates that a remote control input falling edge interrupt is the interrupt factor.

<RMCLDR>: Detects a leader of a received remote control signal

<RMCRNUM[6:0]>: Indicates the number of bits received as remote control signal data. The number cannot be monitored during reception. On completion of reception, the number is stored.

**(Note 1)** This register is updated every time an interrupt is generated.  
Writing to this register is ignored.

**(Note 2)** RMC keeps receiving 73 bit or more data unless reception is completed by detecting the maximum data bit cycle or the excess low width. If so, the received data in the data buffer may not be correct.

## 14.3 Operation Description

### 14.3.1 Reception of Remote Control Signal

#### 14.3.1.1 Sampling Clock

A remote control signal is sampled by low-speed clock (fs).

#### 14.3.1.2 Basic Operation

RMC starts to receive a data bit if a leader is detected while RMC is waiting for a leader. Based on a falling edge cycle, the data bit is determined as 0 or 1. By detecting a leader while RMC is waiting for a leader, a leader detection interrupt is generated, and the data bit reception starts. The data bit is determined as 0 or 1 based on a falling edge cycle. RMC is capable of receiving data up to 72bit. Reception is completed by detecting either a maximum data bit cycle or the excess low width. On completion of reception, RMC is waiting for the next leader, and the Remote Control Receive Data Buffer Registers and the Remote Control Receive Status Register are updated.

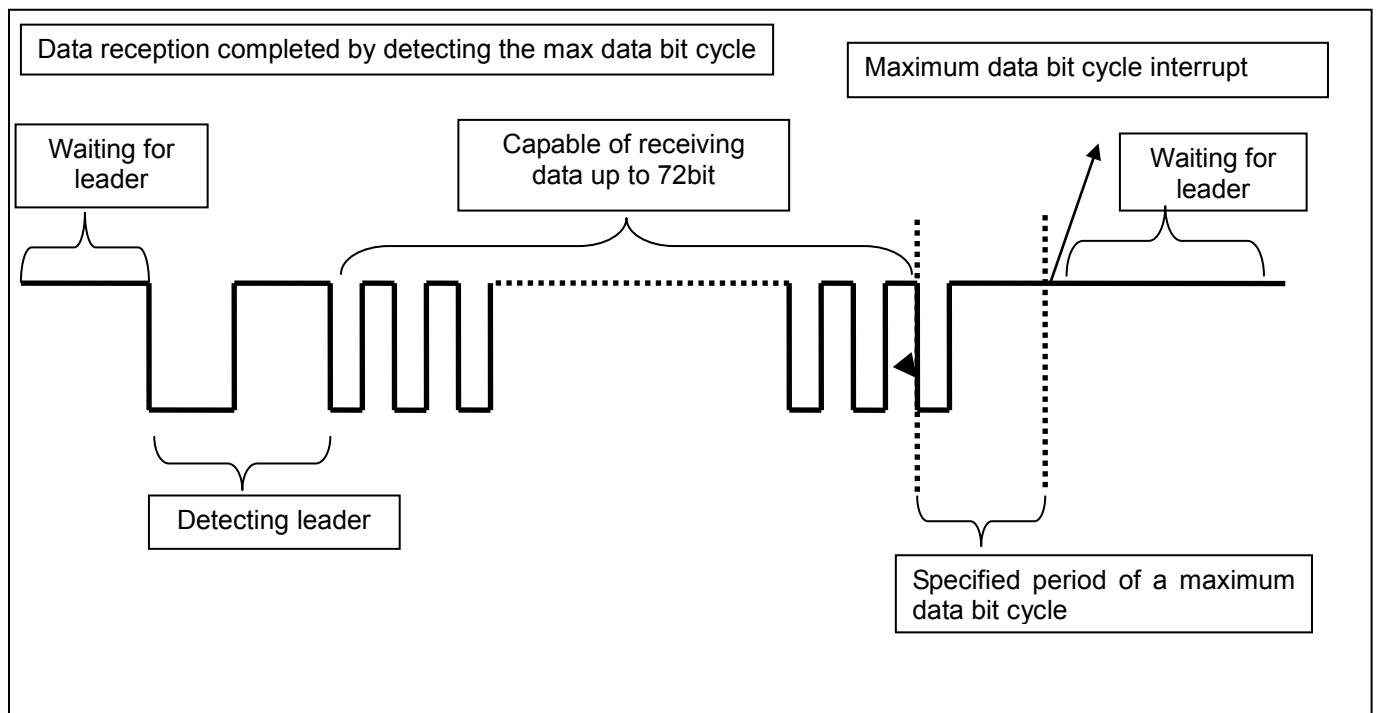

14.3.1.3 Preparation

Configure reception operation of a remote control signal with the Remote Control Signal Receive Control Registers (RMCR1, RMCR2 and RMCR3) before reception.

(1) Settings of Noise Cancelling Time

Configure noise cancelling time with the RMCR4 <RMCNC[3:0]> bit.

RMC monitors a remote control signal in each rising edge of a sampling clock. If “High” is monitored, RMC recognizes that the signal was changed to “Low” after monitoring cycles of “Low” specified in RMCNC. If “Low” is monitored, RMC recognizes that the signal was changed to “High” after monitoring cycles of “High” specified in RMCNC.

The following figure shows how RMC operates according to the noise cancel setting of RMCNC [3:0] = 0011 (3 cycles). Subsequent to noise cancellation, the signal is changed from “High” to “Low” upon monitoring 3 cycles of “Low” s, and the signal is changed from “Low” to “High” upon monitoring 3 cycles of “High” s.

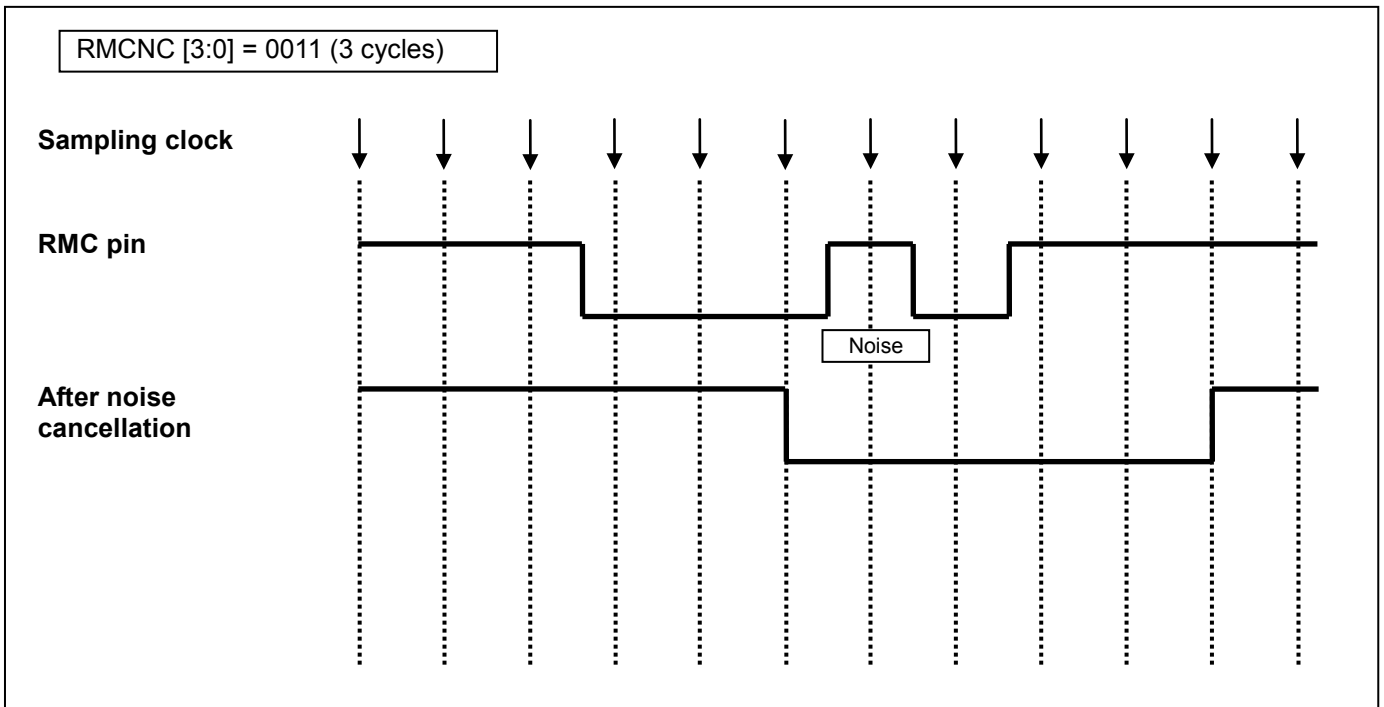

(2) Settings of Detecting Leader

To detect a leader, configure cycle and low width of the leader with the RMCRCR1 <RMCLLMIN[7:0]> <RMCLLMAX[7:0]> <RMCLCMIN[7:0]> <RMCLCMAX[7:0]> bits. When you configure the register, you must follow the rule shown below.

Leader	Rules
Low width + High width	<RMCLCMAX[7:0]> > <RMCLCMIN[7:0]> <RMCLLMAX[7:0]> > <RMCLLMIN[7:0]> <RMCLCMIN[7:0]> > <RMCLLMAX[7:0]>
Only with high width	<RMCLCMAX[7:0]> > <RMCLCMIN[7:0]> <RMCLLMAX[7:0]> = 0x00000000 <RMCLLMIN[7:0]> = don't care
No leader	<RMCLCMAX[7:0]> = 0x00000000 <RMCLCMIN[7:0]> = don't care <RMCLLMAX[7:0]> = don't care <RMCLLMIN[7:0]> = don't care

The following shows a leader waveform and the RMCRCR1 register settings.

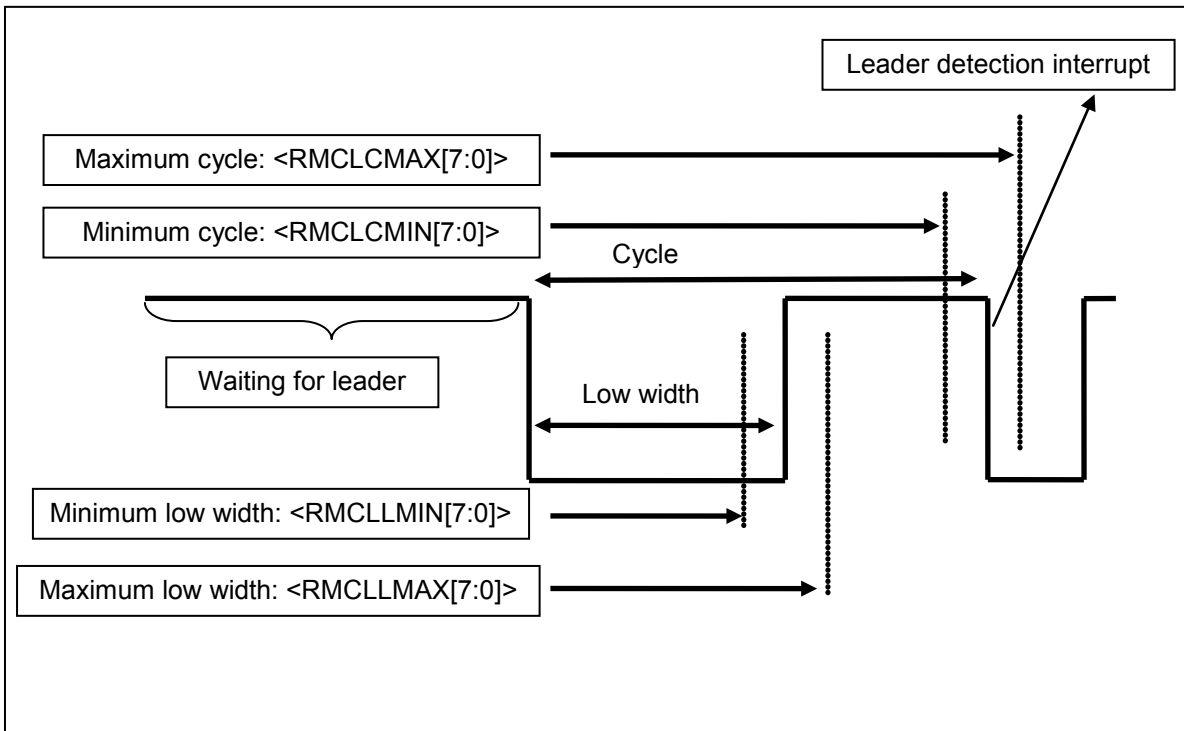

If you want to generate an interrupt when detecting a leader, configure the RMCRCR2 <RMCLIEN> bit. A remote control signal without a leader cannot generate a leader detection interrupt.

(3) Settings of Data Bit Determination

Based on a falling edge cycle, the data bit is determined as 0 or 1.

Configure a threshold of the determination with the RMCRCR3 <RMCDATL[6:0]> bit. If the cycle exceeds the threshold, the bit is determined as "1". If not, the bit is determined as "0".

By setting "1" to the RMCRCR2 <RMCEDIEN> bit, a remote control signal input falling edge interrupt can be generated in each falling edge of the data bit. Using this interrupt together with a 16-bit timer enables the determination to be done by software.

The following shows how the data bit is determined as "0" or "1".

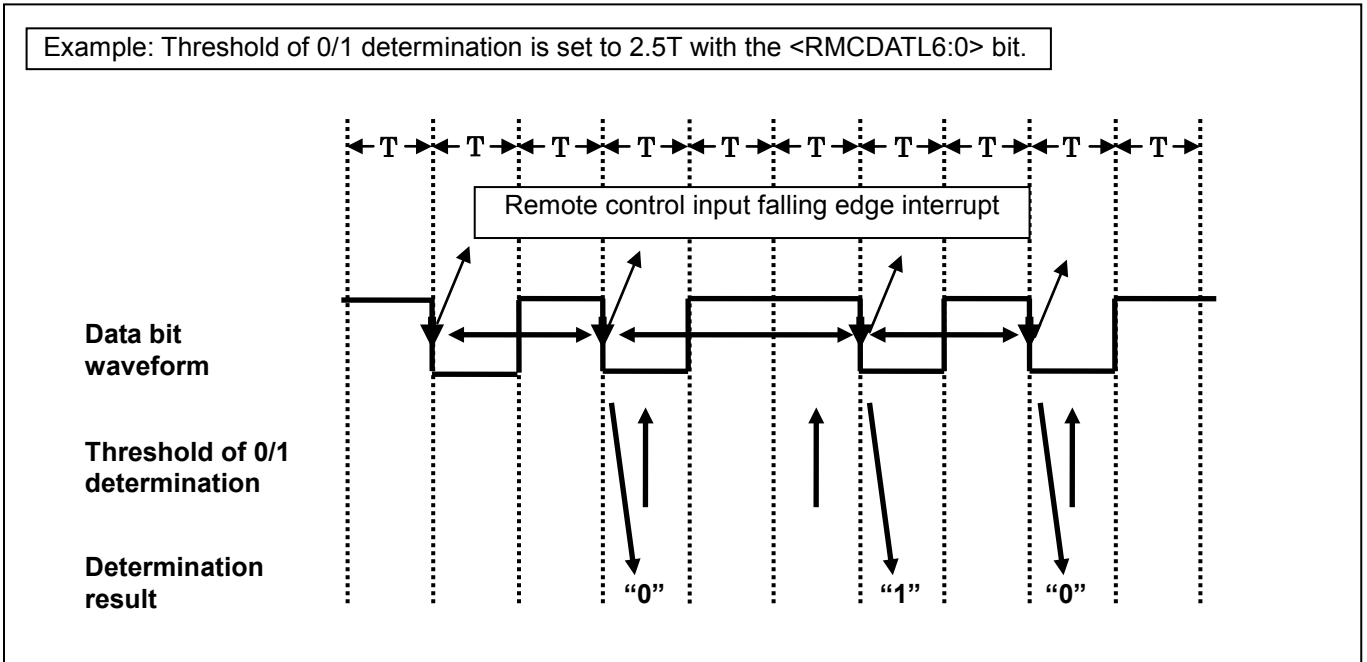

As for data bit determination of a remote control signal in a phase method, see 14.3.1.10 "Receiving a Remote Control Signal in a Phase Method".

(4) Settings of Reception Completion

To complete data reception, settings of detecting the maximum data bit cycle and excess low width are required. If multiple factors are specified, reception is completed by the factor detected first. Make sure to configure the reception completion settings.

1) Completed by a maximum data bit cycle

To complete reception by detecting a maximum data bit cycle, you need to configure the RMCRCR2 <RMCDMAX[7:0]> bits. If the falling edge of the data bit cycle isn't monitored after time specified as threshold in the <RMCDMAX[7:0]> bits, a maximum data bit cycle is detected. The detection completes reception and generates an interrupt.

2) Completed by excess low width

To complete reception by detecting the low width, you need to configure the RMCRCR2 <RMCLL[7:0]> bits. After the falling edge of the data bit is detected, if the signal stays low longer than specified, excess low width is detected. The detection completes reception and generates an interrupt.

#### 14.3.1.4 Enabling Reception

By enabling the RMCREN <RMCREN> bit after configuring the RMCRCR1, RMCRCR2, RMCRCR3 and RMCRCR4 registers, RMC is ready for reception. Detecting a leader initiates reception.

**(Note) Changing the configurations of the RMCRCR1, RMCRCR2, RMCRCR3 and RMCRCR4 registers during reception may harm their proper operation. Be careful if you change them during reception.**

#### 14.3.1.5 Reception

Detecting a leader sets the RMCSTAT <RMCRLDR> bit. Simultaneously, a leader detection interrupt is generated if the RMCRCR2 <RMCLIEN> bit is set. When the interrupt is generated, the RMCSTAT <RMCRLIF> bit is set.

Next to the leader detection, each data bit is determined as 0 or 1. The results are stored in the RMCRCR1, RMCRCR2 and RMCRCR3 registers up to 72bit. By setting "1" to the RMCRCR2 <RMCEDIEN> bit, a remote control signal input falling edge interrupt can be generated in each falling edge of the data bit. When the interrupt is generated, the RMCSTAT <RMCEDIF> bit is set.

Detecting the maximum data bit cycle or the excess low width completes reception and generates an interrupt.

To check the status of RMC after reception is completed, read the Remote Control Receive Status Register.

On completion of reception, RMC is waiting for the next leader.

By setting RMC to receive a signal without a leader, RMC recognizes the received data and starts reception without detecting a leader.

If the next data reception is completed before reading the preceding received data, the preceding data is overwritten by the next one.

14.3.1.6 Reception Completion

1) Completed by a maximum data bit cycle

Detecting a maximum data bit cycle completes reception and generates an interrupt. After the interrupt is generated, the RMCRSTAT <RMCDMAXIF> bit is set to "1".

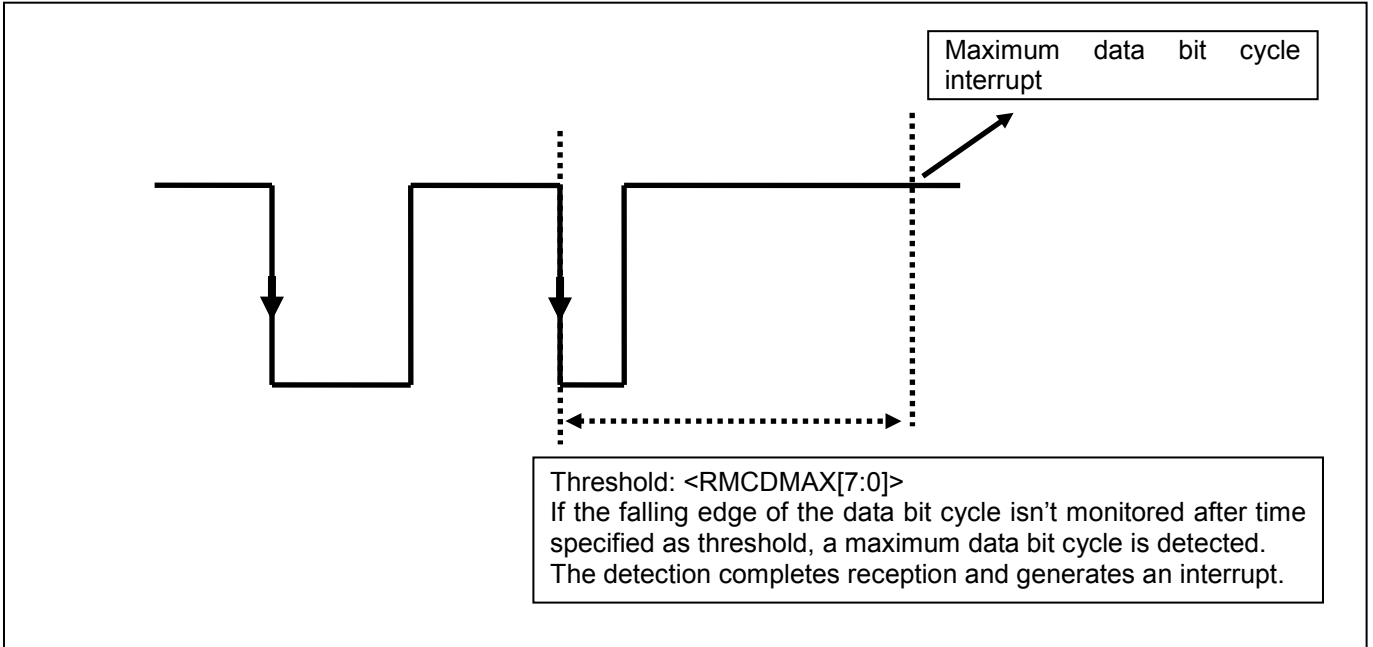

2) Completed by excess low width

Detecting excess low width completes reception and generates an interrupt. After the interrupt is generated, the RMCRSTAT <RMCLOIF> bit is set to "1".

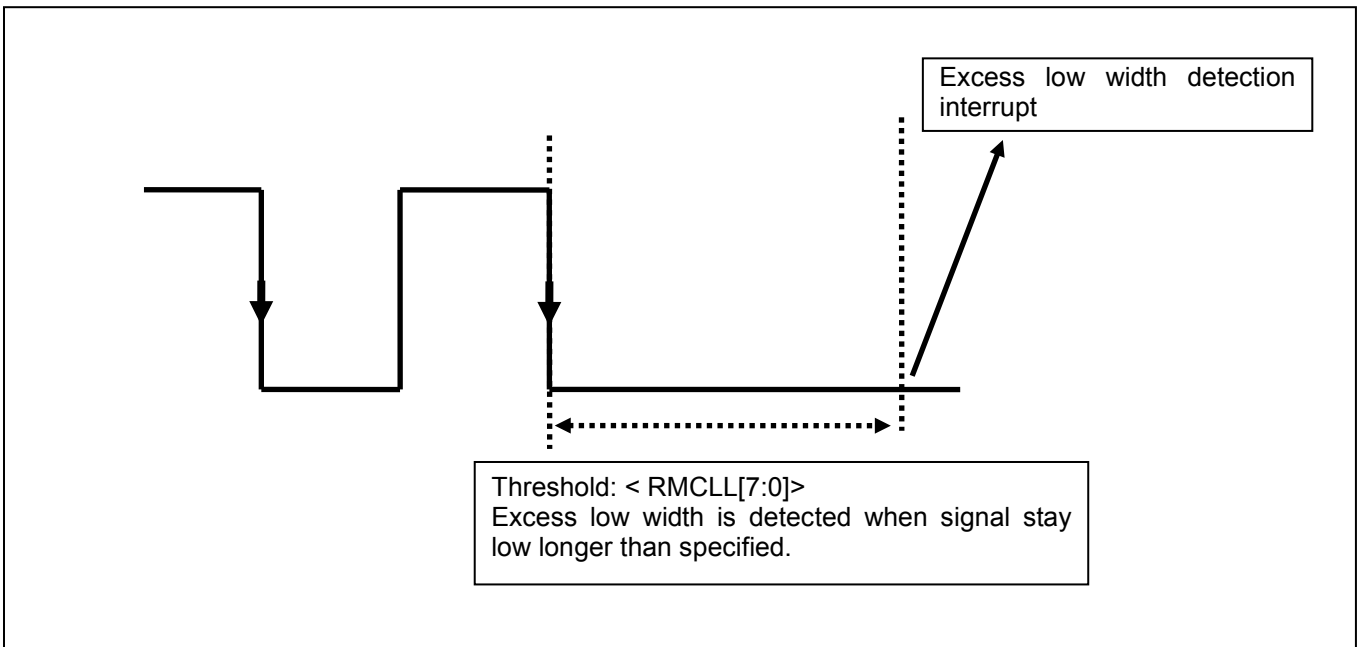

RMC keeps receiving 73 bit or more data unless reception is completed by detecting the maximum data bit cycle or the excess low width. If so, the received data in the data buffer may not be correct.

To check the status of RMC after reception is completed, read the Remote Control Receive Status Register. The status of RMC that each bit type indicates is shown below.

<RMCRLDR>	<RMCRNUM[6:0]>	RMC Status
0	0000001~1001000	Receiving remote control signal without a leader (Data bits: 1~72bit)
0	1001001~1111111	Receiving remote control signal without a leader (Data bits: 73bit and more)
1	0000000	Only with a leader
1	0000001~1001000	Receiving remote control signal with a leader (Data bits: 1~72bit)
1	1001001~1111111	Receiving remote control signal without a leader (Data bits: 73bit and more)

14.3.1.7 Stopping Reception

RMC stops reception by clearing the RMCREN <RMCREN> bit to "0" (reception disabled). Clearing this bit during reception stops reception immediately and the received data is discarded.

14.3.1.8 Receiving Remote Control Signal without Leader

Setting RMCRCR2 <RMCLD> enables RMC to receive signals with or without a leader. By setting RMCRCR2 <RMCLD>, RMC starts receiving data if it recognizes a signal of which low width is shorter than a maximum low width of leader detection specified in the RMCRCR1 <RMCLLMAX[7:0]> bits. RMC keeps receiving data until the final data bit is received.

If RMCRCR2 <RMCLD> is enabled, the same settings of error detection, reception completion and data bit determination of 0 or 1 are applied regardless of whether a signal has a leader or not. Thus receivable remote control signals are limited.

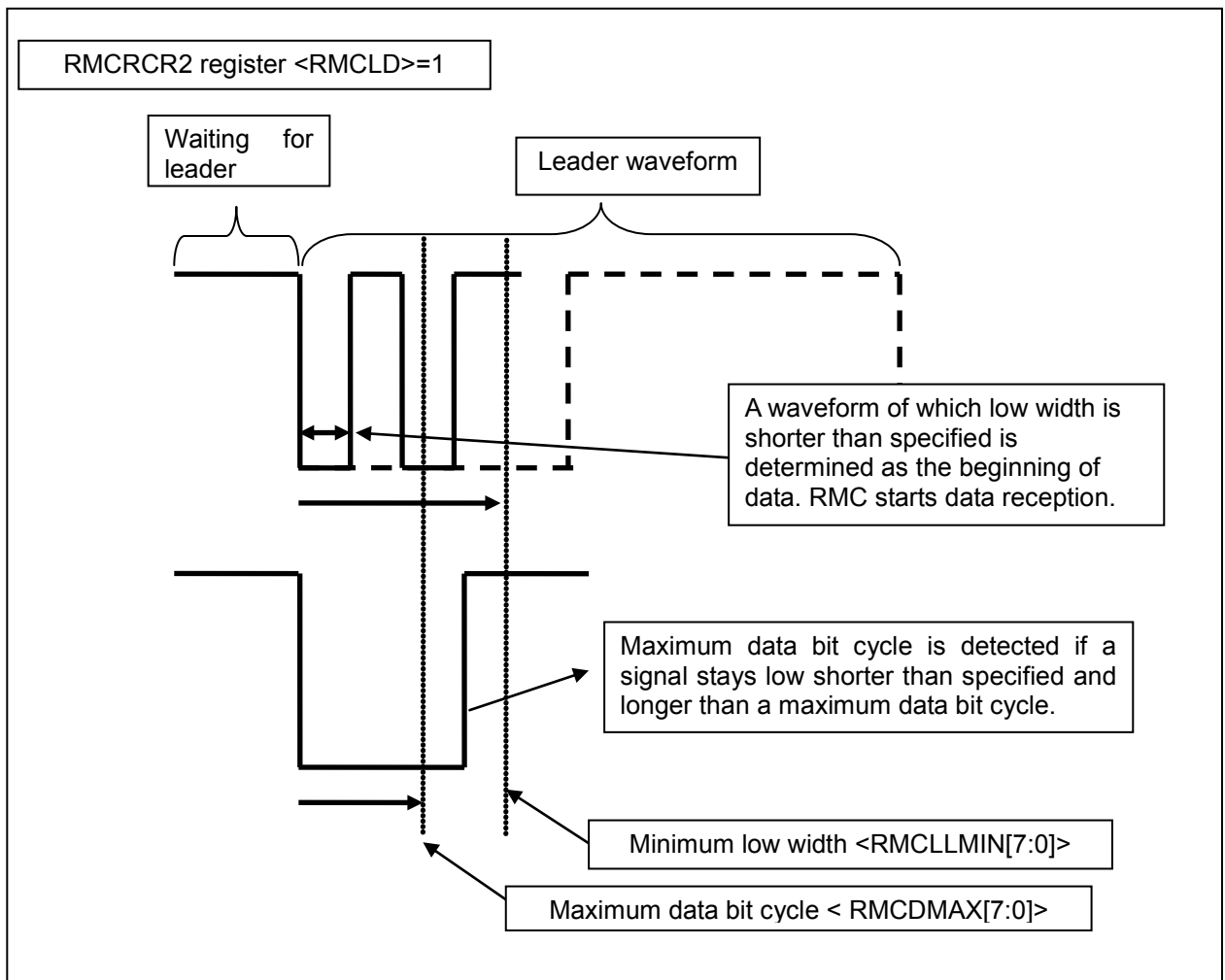

#### 14.3.1.9 A Leader only with Low Width

The figure shown below illustrates a remote control signal that starts with a leader of which waveform only has low width. This signal starts with a leader that only has low width and a data bit cycle starts from the rising edge. To enable the signal, it must be sent after being reversed by setting the RMCRCR4 <RMCPO> bit to "1". This is because RMC is configured to detect a data bit cycle from the falling edge.

A leader is detected by the low width. When you configure the RMCRCR1 register, you must follow the rule shown below.

```
<RMCLLMAX[7:0]> = 0x00000000  
<RMCLCMAX[7:0]> > <RMCLCMIN[7:0]>
```

If the rules are applied, RMC does not care about the value of <RMCLLMIN[7:0]>.

To determine the data bit as 0 or 1, configure a threshold of the determination with the RMCRCR3 <RMCDATL[6:0]> bit.

Configure a maximum data bit cycle with the <RMCDMAX[7:0]> bits of the Remote Control Receive Control Register 2.

To complete reception by detecting the maximum data bit cycle, you need to configure the RMCRCR2 <RMCDMAX[7:0]> bits. To complete reception by detecting the low width, you need to configure the RMCRCR2 <RMCLL[7:0]> bits. Detecting the maximum data bit cycle or the excess low width completes reception and generates an interrupt. RMC waits for the next leader.

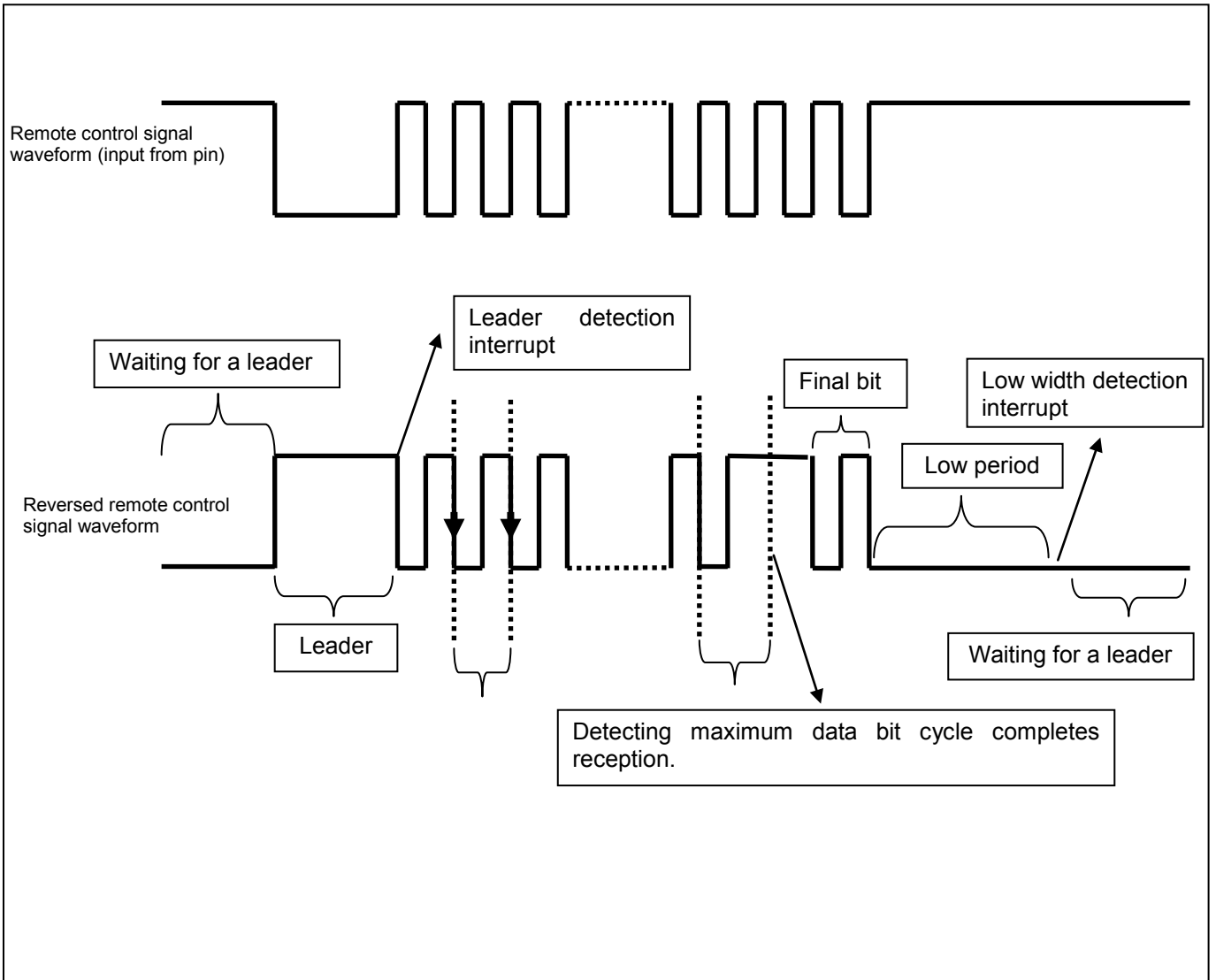

**14.3.1.10 Receiving a Remote Control Signal in a Phase Method**

RMC is capable of receiving a remote control signal in a phase method of which signal cycle is fixed. A signal in the phase method has three waveform patterns (see the figure shown below). By setting two thresholds a remote control signal pattern is determined. RMC converts the signal into data "0" or "1". On completion of reception, received data "0" and "1" are stored in the RMCRCR3, RMCRCR2 and RMCRCR1.

By setting RMCRCR2<RMCPPHM>="1", RMC enables to receive a remote control signal in the phase method. Each threshold can be configured with the RMCRCR3<RMCDDL[6:0]> bits and <RMCDDH[6:0]> bits. Two thresholds are used to distinguish three waveform patterns. On condition that a cycle between two falling edges is "T", three patterns show cycles of 1T, 1.5T and 2T. Details of the two thresholds are shown below.

To determine a remote control signal in the phase method, three patterns of data waveform and preceding data are required. In addition, the signal needs to start from data "1".

	Determined by	Threshold	Register bits to set
Threshold 1	Pattern 1 & pattern 2	1T~1.5T	RMCRCR3 register <RMCDDL[6:0]>
Threshold 2	Pattern 2 & pattern 3	1.5T~2T	RMCRCR3 register <RMCDDH[6:0]>

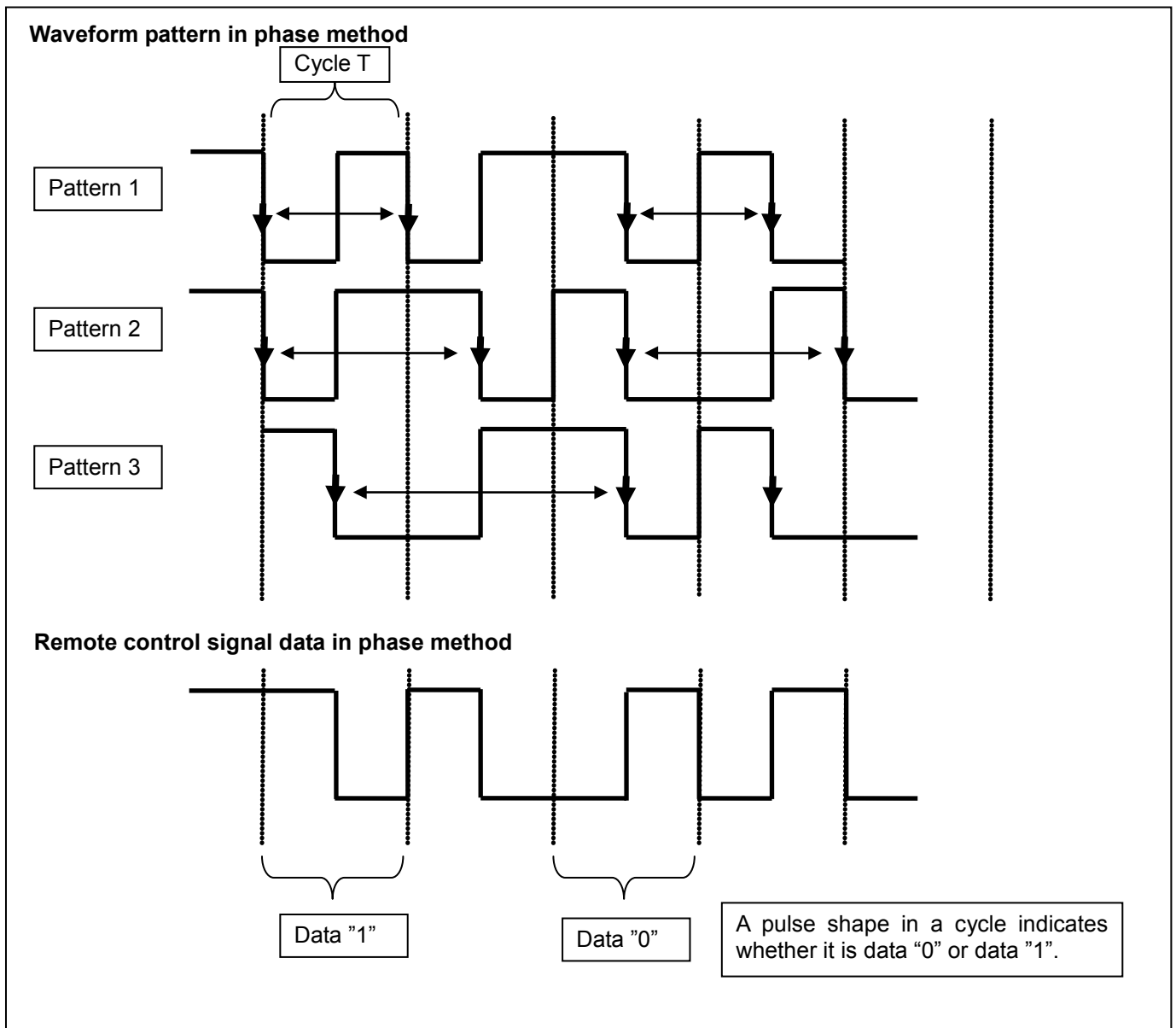

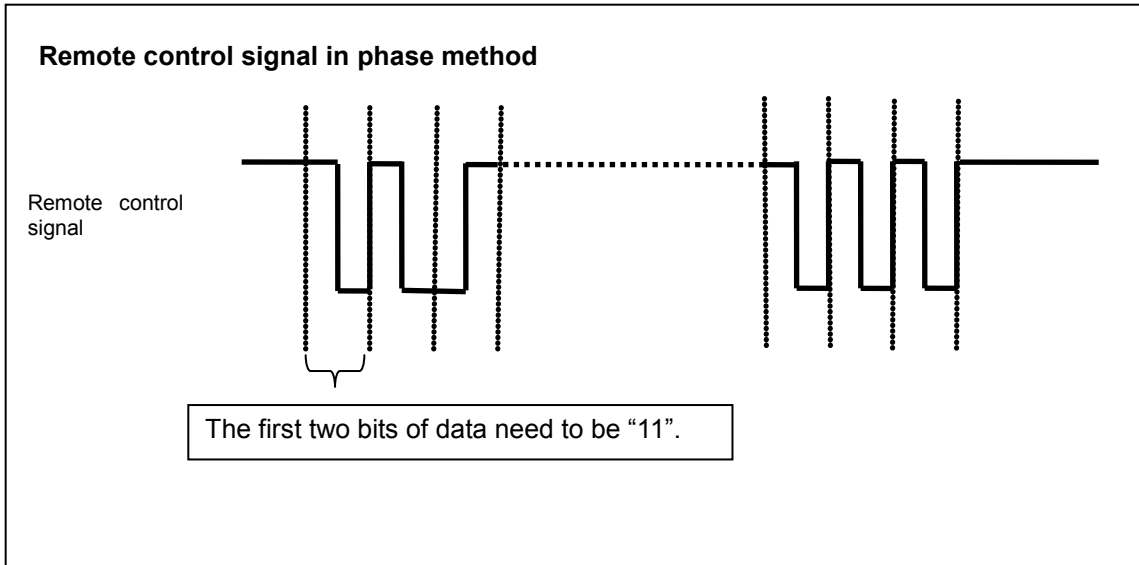

## 15 Analog/Digital Converter

A 10-bit, sequential-conversion analog/digital converter (A/D converter) is built into the TMPM330. This A/D converter is equipped with 12 analog input channels.

Fig. 15-1 shows the block diagram of this A/D converter.

These 12 analog input channels (pins AN0 through AN11) are also used as input/ output ports.

**(Note)** If it is necessary to reduce a power current by operating the TMPM330 in IDLE or STOP mode and if either case shown below is applicable, you must first stop the A/D converter and then execute the instruction to put the TMPM330 into standby mode:

- 1) The TMPM330 must be put into IDLE mode when ADMOD1<I2AD> is "0."
- 2) The TMPM330 must be put into STOP mode.

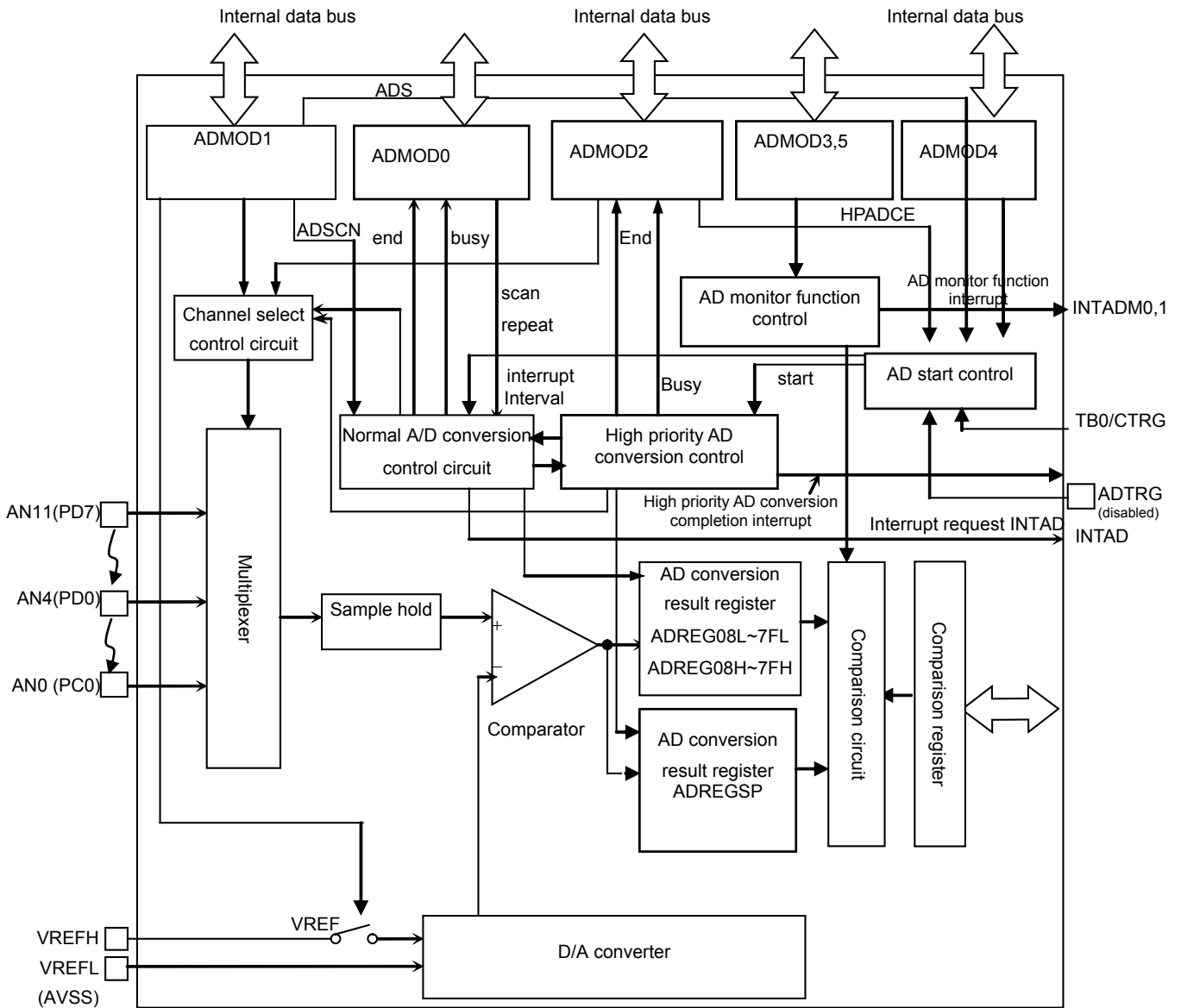

Fig. 15-1 A/D Converter Block Diagram

## 15.1 Registers

The control registers and addresses of the A/D converter are as follows.

Register name		Address
A/D Conversion Clock Setting Register	ADCLK	0x4003_0000
A/D Mode Control Register 0	ADMOD0	0x4003_0004
A/D Mode Control Register 1	ADMOD1	0x4003_0008
A/D Mode Control Register 2	ADMOD2	0x4003_000C
A/D Mode Control Register 3	ADMOD3	0x4003_0010
A/D Mode Control Register 4	ADMOD4	0x4003_0014
A/D Mode Control Register 5	ADMOD5	0x4003_0018
A/D Conversion Accuracy Setting Register (Note)	ADCBAS	0x4003_0020
Lower A/D Conversion Result Register 08L	ADREG08L	0x4003_0030
Upper A/D Conversion Result Register 08H	ADREG08H	0x4003_0031
Lower A/D Conversion Result Register 19L	ADREG19L	0x4003_0034
Upper A/D Conversion Result Register 19H	ADREG19H	0x4003_0035
Lower A/D Conversion Result Register 2AL	ADREG2AL	0x4003_0038
Upper A/D Conversion Result Register 2AH	ADREG2AH	0x4003_0039
Lower A/D Conversion Result Register 3BL	ADREG3BL	0x4003_003C
Upper A/D Conversion Result Register 3BH	ADREG3BH	0x4003_003D
Lower A/D Conversion Result Register 4CL	ADREG4CL	0x4003_0040
Upper A/D Conversion Result Register 4CH	ADREG4CH	0x4003_0041
Lower A/D Conversion Result Register 5DL	ADREG5DL	0x4003_0044
Upper A/D Conversion Result Register 5DH	ADREG5DH	0x4003_0045
Lower A/D Conversion Result Register 6EL	ADREG6EL	0x4003_0048
Upper A/D Conversion Result Register 6EH	ADREG6EH	0x4003_0049
Lower A/D Conversion Result Register 7FL	ADREG7FL	0x4003_004C
Upper A/D Conversion Result Register 7FH	ADREG7FH	0x4003_004D
Lower A/D Conversion Result Register SP	ADREGSPL	0x4003_0050
Upper A/D Conversion Result Register SP	ADREGSPH	0x4003_0051
Lower A/D Conversion Result Comparison Register 0	ADCMP0L	0x4003_0054
Upper A/D Conversion Result Comparison Register 0	ADCMP0H	0x4003_0055
Lower A/D Conversion Result Comparison Register 1	ADCMP1L	0x4003_0058
Upper A/D Conversion Result Comparison Register 1	ADCMP1H	0x4003_0059

**Note) To assure conversion accuracy, the ADCBAS register must be configured as follows.**

$$0x4003_0020 = 0x58$$

		7	6	5	4	3	2	1	0
ADCBAS	bit Symbol								
	Read/Write	R/W	R/W	R/W	R/W	R/W	R/W	R/W	R/W
	After reset	0	0	1	1	1	0	0	0
	Function	Write "0".	Write "1".	Write "0".	Write "1".	Write "1".	Write "0".	Write "0".	Write "0".

### 15.2 Registers Description

The A/D converter is controlled by A/D mode control registers (ADMOD0, ADMOD1, ADMOD2, ADMOD3, ADMOD4 and ADMOD5). Results of A/D conversion are stored in 16 upper and lower A/D conversion result registers ADREG08H/L through ADREG7FH/L. Results of top-priority conversion are stored in ADREGSPH/L.

Here are the descriptions of the registers.

A/D Mode Control Register 0

	7	6	5	4	3	2	1	0
Bit symbol	EOCFN	ADBFN	/	ITM1	ITM0	REPEAT	SCAN	ADS
Read/Write	R		R	R/W				
After reset	0	0	0	0	0	0	0	0
Function	Normal A/D conversion completion flag 0: Before or during conversion 1: Completion	Normal A/D conversion BUSY flag 0: Conversion stop 1: During conversion	"0" is read.	Specify interrupt in fixed channel repeat conversion mode	Specify interrupt in fixed channel repeat conversion mode.	Specify repeat mode 0: Single conversion mode 1: Repeat conversion mode	Specify scan mode 0: Fixed channel mode 1: Channel scan mode	Start A/D conversion 0: Don't care 1: Start conversion "0" is always read.

Specify A/D conversion interrupt in fixed channel repeat conversion mode

	/	Fixed channel repeat conversion mode <SCAN> = "0", <REPEAT> = "1"
00		Generate interrupt once every single conversion
01		Generate interrupt once every 4 conversions
10		Generate interrupt once every 8 conversions
11		Setting prohibited

Fig. 15-2 A/D Mode Control Register 0

**(Note 1) Please specify the mode first and then specify the <ADS> bit.**

A/D Mode Control Register 1

ADMOD1

	7	6	5	4	3	2	1	0
Bit symbol	VREFON	I2AD	ADSCN	—	ADCH3	ADCH2	ADCH1	ADCH0
Read/Write	R/W							
After reset	0	0	0	0	0	0	0	0
Function	VREF application control 0 : OFF 1 : ON	IDLE 0 : Stop 1 : Operation	Specify operation mode for channel scanning 0: 4ch scan 1: 8ch scan	Write "0."	Select analog input channel			

Select analog input channel

<ADCH[3:0]>	<SCAN>		
	0 Fixed channel	1 Channel scan (ADSCN=0)	1 Channel scan (ADSCN= 1 )
0000	AN0	AN0	AN0
0001	AN1	AN0~AN1	AN0~AN1
0010	AN2	AN0~AN2	AN0~AN2
0011	AN3	AN0~AN3	AN0~AN3
0100	AN4	AN4	AN0~AN4
0101	AN5	AN4~AN5	AN0~AN5
0110	AN6	AN4~AN6	AN0~AN6
0111	AN7	AN4~AN7	AN0~AN7
1000	AN8	AN 8	AN8
1001	AN9	AN8~AN9	AN8~AN9
1010	AN10	AN8~AN10	AN8~AN10
1011	AN11	AN8~AN11	AN8~AN11
1101	Setting prohibited		
1110			
1111			

(Note 1) Before starting AD conversion, write "1" to the <VREFON> bit, wait for 3 μs during which time the internal reference voltage should stabilize, and then write "1" to the ADMOD0<ADS> bit.

(Note 2) To go into standby mode upon completion of AD conversion, set <VREFON> to "0."

Fig. 15-3 A/D Mode Control Register 1

A/D Mode Control Register 2

ADMOD2

	7	6	5	4	3	2	1	0
Bit symbol	EOCFHP	ADBFHP	HPADCE	—	HPADCH3	HPADCH2	HPADCH1	HPADCH0
Read/Write	R	R	R/W					
After reset	0	0	0	0	0	0	0	0
Function	Top-priority AD conversion completion flag 0: Before or during conversion 1: Upon completion	Top-priority AD conversion BUSY flag 0: During conversion halts 1: During conversion	Activate top-priority conversion 0: Don't care 1: Start conversion. "0" is always read.	Write "0".	Select analog input channel when activating top-priority conversion.			

<HPADCH[3:0]>	Analog input channel when executing top-priority conversion
0000	AN0
0001	AN1
0010	AN2
0011	AN3
0100	AN4
0101	AN5
0110	AN6
0111	AN7
1000	AN8
1001	AN9
1010	AN10
1011	AN11
1100	AN12
1101	Setting prohibited
1110	
1111	

Fig. 15-4 A/D Mode Control Register 2

A/D Mode Control Register 3

ADMOD3

	7	6	5	4	3	2	1	0
Bit symbol			ADOBIC	REGS3	REGS2	REGS1	REGS0	ADOBVS
Read/Write	R/W	R	R/W					
After reset	0	0	0	0	0	0	0	0
Function	Write "0".	"0" can be read.	Make AD monitor function interrupt setting 0: Smaller than comparison Reg. 1: Larger than comparison Reg.	BIT for selecting the AD conversion result storage Reg. that is to be compared with the comparison Reg. if the AD monitor function is enabled				AD monitor function 0 : Disable 1 : Enable

<REGS[3:0]>	AD conversion result storage Reg. to be compared
0000	ADREG08
0001	ADREG19
0010	ADREG2A
0011	ADREG3B
0100	ADREG4C
0101	ADREG5D
0110	ADREG6E
0111	ADREG7F
1XXX	ADREGSP

Fig. 15-5 A/D Mode Control Register 3

A/D Mode Control Register 5

ADM05

	7	6	5	4	3	2	1	0
Bit symbol			ADOBIC	REGS3	REGS2	REGS1	REGS0	ADOBVS
Read/Write	R		R/W					
After reset	0	0	0	0	0	0	0	0
Function	"0" can be read.		Make AD monitor function interrupt setting Smaller than comparison Reg. Larger than comparison Reg.	BIT for selecting the AD conversion result storage Reg. that is to be compared with the comparison Reg. if the AD monitor function is enabled .				AD monitor function 0 : Disable 1 : Enable

<REGS[3:0]>	AD conversion result storage Reg. to be compared
0000	ADREG08
0001	ADREG19
0010	ADREG2A
0011	ADREG3B
0100	ADREG4C
0101	ADREG5D
0110	ADREG6E
0111	ADREG7F
1XXX	ADREGSP

Fig. 15-6 A/D Mode Control Register 5

A/D Mode Control Register 4

	7	6	5	4	3	2	1	0
Bit symbol	HADHS	HADHTG	ADHS	ADHTG			ADRST1	ADRST0
Read/Write	R/W				R		W	W
After reset	0	0	0	0	0		0	0
Function	HW source for activating top-priority A/D conversion 0: External TRG 1: Match with TB5RG0	HW for activating top-priority A/D conversion 0: Disable 1: Enable	HW source for activating normal A/D conversion 0: External TRG 1: Match with TB6RG0	HW for activating normal A/D conversion 0: Disable 1: Enable	"0" can be read.		Overwriting 10 with 01 allows ADC to be software reset.	

**(Note 1)** If AD conversion is executed with the match triggers <ADHTG> and <HADHTG> of a 16-bit timer set to "1" by using a source for triggering H/W, A/D conversion can be activated at specified intervals by performing three steps shown below when the timer is idle:

1. Select a source for triggering HW: <ADHS>, <HADHS>
2. Enable H/W activation of AD conversion: <ADHTG>, <HADHTG>
3. Start the timer.

**(Note 2)** Do not make a top-priority AD conversion setting and a normal AD conversion setting simultaneously.

**(Note 3)** The external trigger cannot be used for H/W activation of AD conversion when it is used for H/W activation of top priority AD conversion.

**(Note 4)** A software reset initializes other bits. Resetting a mode register is needed.

**(Note)** The TMPM330 disables the external trigger used for H/W activation. Therefore "0" cannot be set to <HADHS> and <ADHS>.

Fig. 15-7 A/D Mode Control Register 4

Lower A/D Conversion Result Register 08

	7	6	5	4	3	2	1	0
ADREG08L	Bit symbol	ADR01	ADR00				OVR0	ADR0RF
	Read/Write	R		R			R	R
	After reset	0		0			0	0
	Function	Store lower 2 bits of A/D conversion result		"0" can be read.			Over RUN flag 0: Not generate 1: Generate	A/D conversion result storage flag 1: Presence of conversion result

Upper A/D Conversion Result Register 08

	7	6	5	4	3	2	1	0	
ADREG08H	Bit symbol	ADR09	ADR08	ADR07	ADR06	ADR05	ADR04	ADR03	ADR02
	Read/Write	R							
	After reset	0							
	Function	Store upper 8 bits of A/D conversion result							

Lower A/D Conversion Result Register 19

	7	6	5	4	3	2	1	0
ADREG19L	Bit symbol	ADR11	ADR10				OVR1	ADR1RF
	Read/Write	R		R			R	R
	After reset	0		0			0	0
	Function	Store lower 2 bits of A/D conversion result		"0" can be read.			Over RUNflag 0: Not generate 1: Generate	A/D conversion result storage flag 1: Presence of conversion result

Upper A/D Conversion Result Register 19

	7	6	5	4	3	2	1	0	
ADREG19H	Bit symbol	ADR19	ADR18	ADR17	ADR16	ADR15	ADR14	ADR13	ADR12
	Read/Write	R							
	After reset	0							
	Function	Store upper 8 bits of A/D conversion result							

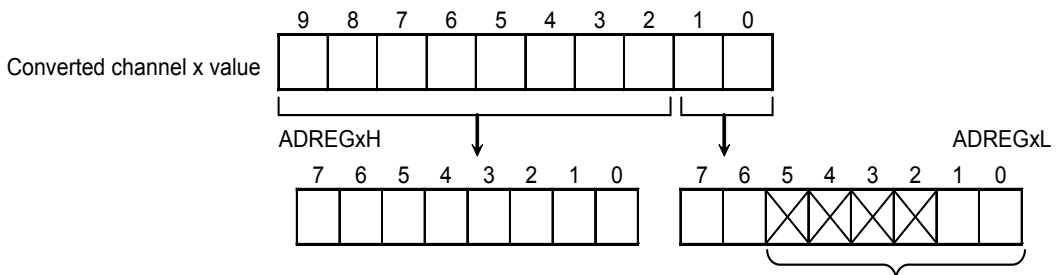

- Bit 0 of ADREG08L/ADREG19L is the A/D conversion result storage flag <ADR<sub>x</sub>RF>. This bit is set to "1" after an A/D converted value is stored. A read of a lower register (ADREG<sub>x</sub>L) will set this bit to "0".
- Bit 1 of ADREG08L/ADREG19L is the over RUN flag <OVR<sub>x</sub>>. This bit is set to "1" if a conversion result is overwritten before both conversion result storage registers (ADREG<sub>x</sub>H and ADREG<sub>x</sub>L) are read. A read of a flag will clear this bit to "0."
- When reading conversion result storage registers on a byte-by-byte basis, first read upper registers and then read lower registers.

Fig. 15-8 A/D Conversion Result Register

Lower A/D Conversion Result Register 2A

	7	6	5	4	3	2	1	0
ADREG2AL	Bit symbol	ADR21	ADR20				OVR2	ADR2RF
	Read/Write	R		R			R	R
	After reset	0		0			0	0
	Function	Store lower 2 bits of A/D conversion result		"0" is read.			Over RUN flag 0: Not generate 1: Generate	A/D conversion result storage flag 1: Presence of conversion result

Upper A/D Conversion Result Register 2A

	7	6	5	4	3	2	1	0	
ADREG2AH	bit Symbol	ADR29	ADR28	ADR27	ADR26	ADR25	ADR24	ADR23	ADR22
	Read/Write	R							
	After reset	0							
	Function	Store upper 8 bits of A/D conversion result							

Lower A/D Conversion Result Register 3B

	7	6	5	4	3	2	1	0
ADREG3BL	bit Symbol	ADR31	ADR30				OVR3	ADR3RF
	Read/Write	R		R			R	R
	After reset	0		0			0	0
	Function	Store lower 2 bits of A/D conversion result		"0" is read.			Over RUN flag 0: Not generate 1: Generate	A/D conversion result storage flag 1: Presence of conversion result

Upper A/D Conversion Result Register 3B

	7	6	5	4	3	2	1	0	
ADREG3BH	bit Symbol	ADR39	ADR38	ADR37	ADR36	ADR35	ADR34	ADR33	ADR32
	Read/Write	R							
	After reset	0							
	Function	Store upper 8 bits of A/D conversion result							

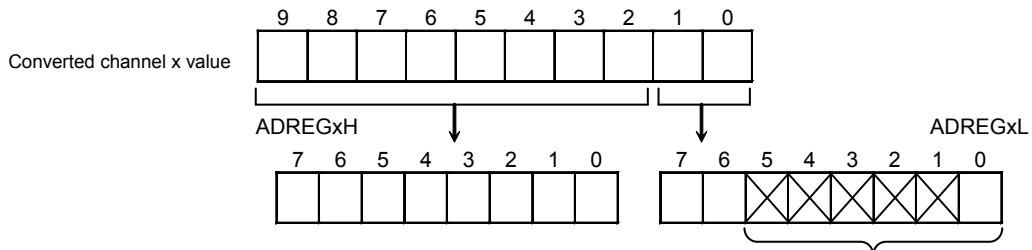

- Bit 0 of the ADREG2AL/ADREG3BL is the A/D conversion result storage flag <ADR2RF>. It is set to "1" after an A/D converted value is stored. A read of a lower register (ADREGxL) will set this bit to "0".
- Bit 1 of the ADREG2AL/ADREG3BL is the over RUN flag <OVRx>. It is set to "1" if a conversion result is overwritten before both conversion result storage registers (ADREGxH,ADREGxL) are read. A read of a flag will clear this bit to "0".
- When reading conversion result storage registers on a byte-by-byte basis, first read upper registers and then read lower registers.

Fig. 15-9 A/D Conversion Result Register

Lower A/D Conversion Result Register 4C

	7	6	5	4	3	2	1	0
ADREG4CL	ADR41	ADR40					OVR4	ADR4RF
Read/Write	R		R				R	R
After reset	0		0				0	0
Function	Store lower 2 bits of A/D conversion result		"0" is read.				Over RUN flag 0: Not generate 1: Generate	A/D conversion result storage flag 1: Presence of conversion result

Upper A/D Conversion Result Register 4C

	7	6	5	4	3	2	1	0
ADREG4CH	ADR49	ADR48	ADR47	ADR46	ADR45	ADR44	ADR43	ADR42
Read/Write	R							
After reset	0							
Function	Store upper 8 bits of A/D conversion result							

Lower A/D Conversion Result Register 5D

	7	6	5	4	3	2	1	0
ADREG5DL	ADR51	ADR50					OVR5	ADR5RF
Read/Write	R		R				R	R
After reset	0		0				0	0
Function	Store lower 2 bits of A/D conversion result		"0" is read.				Over RUN flag 0: Not generate 1: Generate	A/D conversion result storage flag Presence of conversion result

Upper A/D Conversion Result Register 5D

	7	6	5	4	3	2	1	0
ADREG5DH	ADR59	ADR58	ADR57	ADR56	ADR55	ADR54	ADR53	ADR52
Read/Write	R							
After reset	0							
Function	Store upper 8 bits of A/D conversion result							

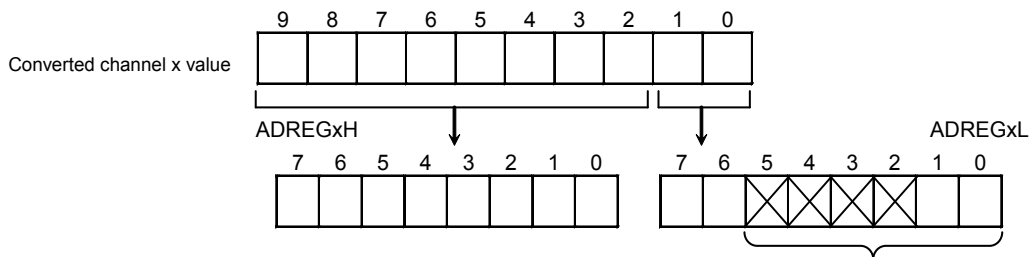

- Bit 0 of the ADREG4CL/ADREG5DL is the A/D conversion result storage flag <ADR<sub>x</sub>RF>. It is set to "1" after an A/D converted value is stored. A read of a lower register (ADREG<sub>x</sub>L) will set this bit to "0".
- Bit 1 of the ADREG4CL/ADREG5DL is the over Run flag <OVR<sub>x</sub>>. It is set to "1" if a conversion result is overwritten before both conversion result storage registers (ADREG<sub>x</sub>H and ADREG<sub>x</sub>L) are read. A read of a flag will clear this bit to "0".
- When reading conversion result storage registers on a byte-by-byte basis, first read upper registers and then read lower registers.

Fig. 15-10 A/D Conversion Result Register

Lower A/D Conversion Result Register 6E

	7	6	5	4	3	2	1	0
ADREG6EL	Bit Symbol	ADR61	ADR60				OVR6	ADR6RF
	Read/Write	R		R			R	R
	After reset	0		0			0	0
	Function	Store lower 2 bits of A/D conversion result		"0" is read.			Over RUN flag 0: Not generate 1: Generate	A/D conversion result storage flag 1: Presence of conversion result

Upper A/D Conversion Result Register 6E

	7	6	5	4	3	2	1	0	
ADREG6EH	Bit Symbol	ADR69	ADR68	ADR67	ADR66	ADR65	ADR64	ADR63	ADR62
	Read/Write	R							
	After reset	0							
	Function	Store upper 8 bits of A/D conversion result							

Lower A/D Conversion Result Register 7F

	7	6	5	4	3	2	1	0
ADREG7FL	Bit Symbol	ADR71	ADR70				OVR7	ADR7RF
	Read/Write	R		R			R	R
	After reset	0		0			0	0
	Function	Store lower 2 bits of A/D conversion result		"0" is read.			Over RUN flag 0: Not generate 1: Generate	A/D conversion result storage flag 1: Presence of conversion result

Upper A/D Conversion Result Register 7F

	7	6	5	4	3	2	1	0	
ADREG7FH	Bit Symbol	ADR79	ADR78	ADR77	ADR76	ADR75	ADR74	ADR73	ADR72
	Read/Write	R							
	After reset	0							
	Function	Store upper 8 bits of A/D conversion result							

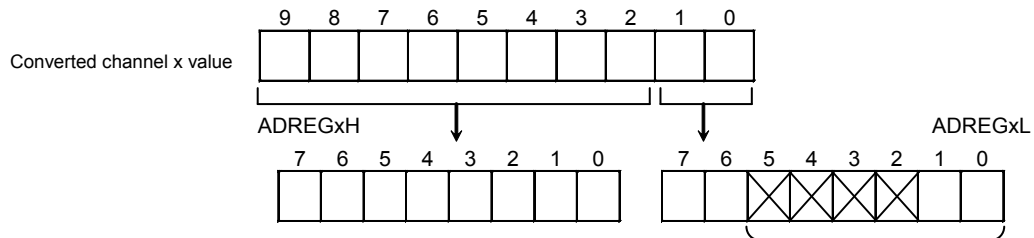

- Bit 0 of the ADREG6EL/ADREG7FL is the A/D conversion result storage flag <ADR<sub>x</sub>RF>. It is set to "1" if an A/D converted value is stored. A read of a lower register (ADREG<sub>x</sub>L) will set this bit to "0".
- Bit 1 of the ADREG6EL/ADREG7FL is the over Run flag <OVR<sub>x</sub>>. It is set to "1" if a conversion result is overwritten before both conversion result storage registers (ADREG<sub>x</sub>H and ADREG<sub>x</sub>L) are read. A read of a flag will clear this bit to "0".
- When reading conversion result storage registers on a byte-by-byte basis, first read upper registers and then read lower registers.

Fig. 15-11 A/D Conversion Result Register

Lower A/D Conversion Result Register SP

	7	6	5	4	3	2	1	0
ADREGSPL	Bit symbol	ADRSP1	ADRSP0				OVRSP	ADRSPRF
	Read/Write	R			R			R
	After reset	0			0			0
	Function	Store lower 2 bits of A/D conversion result			"0" is read.			Over RUN flag 0: Not generate 1: Generate  A/D conversion result storage flag 1: Presence of conversion result

Upper A/D Conversion Result Register SP

	7	6	5	4	3	2	1	0	
ADREGSPH	Bit symbol	ADRSP9	ADRSP8	ADRSP7	ADRSP6	ADRSP5	ADRSP4	ADRSP3	ADRSP2
	Read/Write	R							
	After reset	0							
	Function	Store upper 8 bits of A/D conversion result							

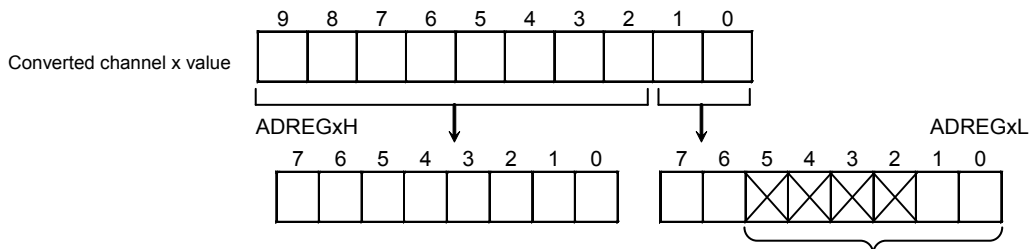

- Bit 0 of the ADREGSP is the A/D conversion result storage flag <ADR<sub>x</sub>RF>. It is set to "1" after an A/D converted value is stored. A read of a lower register (ADREG<sub>x</sub>L) will set this bit to "0."
- Bit 1 of the ADREGSP is the over RUN flag <OVR<sub>x</sub>>. It is set to "1" if a conversion result is overwritten before both conversion result storage registers (ADREG<sub>x</sub>H and ADREG<sub>x</sub>L) are read. A read of a flag will clear this bit to "0".
- When reading conversion result storage registers on a byte-by-byte basis, first read upper registers and then read lower registers.

Fig. 15-12 A/D Conversion Result Register

Lower A/D Conversion Result Comparison Register 0

	7	6	5	4	3	2	1	0
ADCMP0L	Bit symbol	ADR021	ADR020					
	Read/Write	R/W		R				
	After reset	0		0				
	Function	Store lower 2 bits of A/D conversion result comparison		"0" is read.				

Upper A/D Conversion Result Comparison Register 0

	7	6	5	4	3	2	1	0	
ADCMP0H	Bit symbol	ADR029	ADR028	ADR027	ADR026	ADR025	ADR024	ADR023	ADR022
	Read/Write	R/W							
	After reset	0							
	Function	Store upper 8 bits of A/D conversion result comparison							

Lower A/D Conversion Result Comparison Register 1

	7	6	5	4	3	2	1	0
ADCMP1L	Bit symbol	ADR121	ADR120					
	Read/Write	R/W		R				
	After reset	0		0				
	Function	Store lower 2 bits of A/D conversion result comparison		"0" is read.				

Upper A/D Conversion Result Comparison Register 1

	7	6	5	4	3	2	1	0	
ADCMP1H	Bit symbol	ADR129	ADR128	ADR127	ADR126	ADR125	ADR124	ADR123	ADR122
	Read/Write	R/W							
	After reset	0							
	Function	Store upper 8 bits of A/D conversion result comparison							

**(Note)** To set or change a value in this register, the AD monitor function must be disabled (ADMOD3, 5 <ADOBSVx>="0").

Fig. 15-13 A/D Conversion Result Register

### 15.3 Conversion Clock

- The conversion time is calculated by the 46 conversion clock.

A/D Conversion Clock Setting Register

	7	6	5	4	3	2	1	0
Bit symbol	TSH3	tSH2	tSH1	tSH0	\	ADCLK2	ADCLK1	ADCLK0
Read/Write	R/W	R/W	R/W	R/W		R	R/W	R/W
After reset	1	0	0	0	0	0	0	0
Function	Select the A/D sample hold time 1000: 8 conversion clock      1001: 16 conversion clock 1010: 24 conversion clock    1011: 32 conversion clock 0011: 64 conversion clock 1100: 128 conversion clock    1101: 512 conversion clock The setup other than those above: reserved				"0" is read.	Select the A/D prescaler output 000: fc 001: fc/2 010: fc/4 011: fc/8 100: fc/16 111:reserved		

Fig. 15-14 A/D Conversion Clock Setting Register

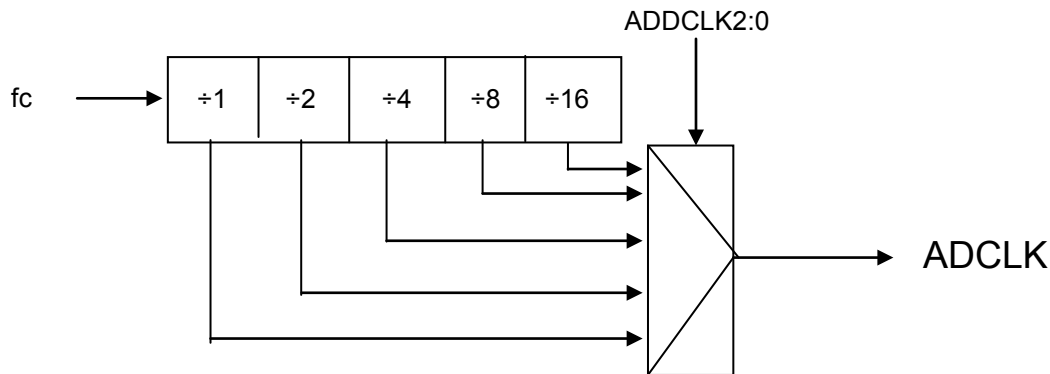

Example: If  $f_{sys} = f_c = 32 \text{ MHz} / 54 \text{ MHz}$

Prescaler <ADDCLK[2:0]>	tconv.(conversion time) 40MHz	tconv. (conversion time) 32MHz
1	1.15µs	1.44µs
1/2	2.3µs	2.88µs
1/4	4.6µs	5.75µs

Variable S/H time

Conversion clock	S/H time 40MHz	tconv. (conversion time)
40MHz	Conversion clk*8 (0.2 µs)	1.15µs
	Conversion clk*16 (0.4 µs)	1.35µs
	Conversion clk*24 (0.6 µs)	1.55µs
	Conversion clk*32 (0.8 µs)	1.75µs
	Conversion clk*64 (1.6 µs)	2.55µs
	Conversion clk*128 (3.2 µs)	4.15µs
	Conversion clk*512 (12.8 µs)	13.75µs

**(Note) Please do not change the analog to digital conversion clock setting during the analog to digital conversion.**

Fig. 15-15 A/D Conversion Time

## 15.4 Description of Operations

### 15.4.1 Analog Reference Voltage

The "H" level of the analog reference voltage shall be applied to the VREFH pin, and the "L" level shall be applied to the VREFL pin. By writing "0" to the ADMOD1<VREFON> bit, a switched-on state of VREFH-VREFL can be turned into a switched-off state. To start AD conversion, make sure that you first write "1" to the <VREFON> bit, wait for 3 μs during which time the internal reference voltage should stabilize, and then write "1" to the ADMOD0<ADS> bit.

### 15.4.2 Selecting the Analog Input Channel

How the analog input channel is selected is different depending on A/D converter operation mode used.

#### (1) Normal AD conversion mode

- If the analog input channel is used in a fixed state (ADMOD0<SCAN>="0"): One channel is selected from analog input pins AIN0 through AIN11 by setting ADMOD1<ADCH[3:0]> to an appropriate setting.
- If the analog input channel is used in a scan state (ADMOD0<SCAN>="1"): One scan mode is selected from 12 scan modes by setting ADMOD1<ADCH[3:0]> and ADSCN to appropriate settings.

#### (2) Top-priority AD conversion mode

One channel is selected from analog input pins AIN0 through AIN11 by setting ADMOD2<HPADCH[3:0]> to an appropriate setting.

After a reset, ADMOD0<SCAN> is initialized to "0" and ADMOD1<ADCH[3:0]> is initialized to "0000." This initialization works as a trigger to select a fixed channel input through the AN0 pin. The pins that are not used as analog input channels can be used as ordinary input ports.

If top-priority AD conversion is activated during normal AD conversion, normal AD conversion is discontinued, top-priority AD conversion is executed and completed, and then normal AD conversion is resumed.

Example:

A case in which repeat-scan conversion is ongoing at channels AIN0 through AIN3 with ADMOD0<REPEAT:SCAN> set to "11" and ADMOD1<ADCH[3:0]> set to 0011, and top-priority AD conversion has been activated at AIN12 with ADMOD2<HPADCH[3:0]>=1100.

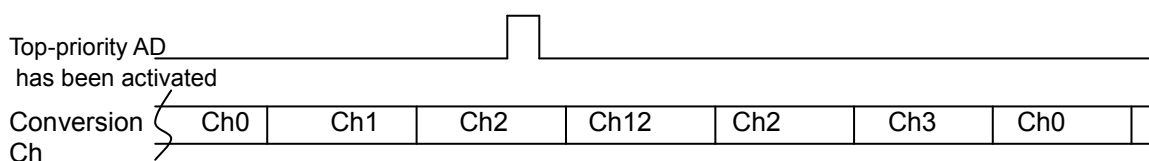

### 15.4.3 Starting A/D Conversion

Two types of A/D conversion are supported: normal AD conversion and top-priority AD conversion. Normal AD conversion is software activated by setting ADMOD0<ADS> to "1." Top-priority AD conversion is software activated by setting ADMOD2<HPADCE> to "1." 4 operation modes are made available to normal AD conversion. In performing normal AD conversion, one of these operation modes must be selected by setting ADMOD0<[2:1]> to an appropriate setting. For top-priority AD conversion, only one operation mode can be used: fixed channel single conversion mode. Normal AD conversion can be activated using the HW activation source selected by ADMOD3<ADHS>, and top-priority AD conversion can be activated using the HW activation source selected by ADMOD3<HADHS>. If this bit is "0," normal and top-priority AD conversions are activated in response to the input of a falling edge through the  $\overline{\text{ADTRG}}$  pin. If this bit is "1," normal AD conversion is activated in response to TB6RG0 generated by the 16-bit timer 6, and top-priority AD conversion is activated in response to TB5RG0 generated by the 16-bit timer 5. Software activation is still valid even after H/W activation has been authorized.

**(Note) When an external trigger is used for the HW activation source of a top priority analog to digital conversion, an external trigger cannot usually be set for activating analog to digital conversion HW.**

**(Note) The TMPM330 disables the external trigger used for H/W activation. Therefore "0" cannot be set to <HADHS> and <ADHS>.**

When normal A/D conversion starts, the A/D conversion Busy flag (ADMOD0<ADBF>) showing that A/D conversion is under way is set to "1." When top-priority A/D conversion starts, the A/D conversion Busy flag (ADMOD2<ADBFHP>) showing that A/D conversion is under way is set to "1." At that time, the value of the Busy flag for normal A/D conversion before the start of top-priority A/D conversion is retained. The value of the conversion completion flag EOCFN for normal A/D conversion before the start of top-priority A/D conversion can also be retained.

**(Note) Normal A/D conversion must not be activated when top-priority A/D conversion is under way. In that case, the top-priority A/D conversion completion flag cannot be set, and the flag for previous normal A/D conversion cannot be cleared.**

To reactivate normal A/D conversion while the conversion is under way, a software reset (ADMOD4<ADRST[1:0]>) must be performed before starting A/D conversion. The HW activation method must not be used to reactivate normal A/D conversion.

If ADMOD2<HPADCE> is set to "1" during normal A/D conversion, ongoing A/D conversion is discontinued and top-priority A/D conversion starts; specifically, A/D conversion (fixed channel single conversion) is executed for a channel designated by ADMOD2<[3:0]>. After the result of this top-priority A/D conversion is stored in the storage register ADREGSP, normal A/D conversion is resumed.

If HW activation of top-priority A/D conversion is authorized during normal A/D conversion, ongoing A/D conversion is discontinued when requirements for activation using a resource are met, and top-priority A/D conversion (fixed channel single conversion) starts for a channel designated by ADMOD2<[3:0]>. After the result of this top-priority A/D conversion is stored in the storage register ADREGSP, normal A/D conversion is resumed.

#### 15.4.4 A/D Conversion Modes and A/D Conversion Completion Interrupts

For A/D conversion, the following four operation modes are supported. For normal A/D conversion, an operation mode can be selected by setting ADMOD0<[2:1]> to an appropriate setting. For top-priority A/D conversion, the fixed channel single conversion mode is automatically selected, irrespective of the ADMOD0<[2:1]> setting.

- Fixed channel single conversion mode
- Channel scan single conversion mode
- Fixed channel repeat conversion mode
- Channel scan repeat conversion mode

##### (1) Normal A/D conversion

An operation mode is selected with ADMOD0<REPEAT, SCAN>. As A/D conversion starts, ADMOD0<ADBFN> is set to "1." When specified A/D conversion is completed, the A/D conversion completion interrupt (INTAD) is generated, and ADMOD0<EOCF> showing the completion of A/D conversion is set to "1." If <REPEAT>="0," <ADBFN> returns to "0" concurrently with the setting of EOCF. If <REPEAT> is set to "1," <ADBFN> remains at "1" and A/D conversion continues.

##### 1. Fixed channel single conversion mode

If ADMOD0 <REPEAT, SCAN> is set to "00," A/D conversion is performed in the fixed channel single conversion mode.

In this mode, A/D conversion is performed once for one channel selected. After A/D conversion is completed, ADMOD0<EOCF> is set to "1," ADMOD0<ADBF> is cleared to "0," and the interrupt request INTAD is generated. <EOCF> is cleared to "0" upon read.

##### 2. Channel scan single conversion mode

If ADMOD0 <REPET,SCAN> is set to "01," A/D conversion is performed in the channel scan single conversion mode.

In this mode, A/D conversion is performed once for each scan channel selected. After A/D scan conversion is completed, ADMOD0<EOCF> is set to "1," ADMOD0<ADBF> is cleared to "0," and the interrupt request INTAD is generated. <EOCF> is cleared to "0" upon read.

### 3. Fixed channel repeat conversion mode

If ADMOD0<REPEAT,SCAN> is set to "10," A/D conversion is performed in fixed channel repeat conversion mode.

In this mode, A/D conversion is performed repeatedly for one channel selected. After A/D conversion is completed, ADMOD <EOCF> is set to "1." ADMOD0 <ADBF> is not cleared to "0." It remains at "1." The timing with which the interrupt request INTAD is generated can be selected by setting ADMOD0 <ITM[1:0]> to an appropriate setting. <EOCF> is set with the same timing as this interrupt INTAD is generated.

<EOCF> is cleared to "0" upon read.

With <ITM[1:0]> set to "00," an interrupt request is generated each time one A/D conversion is completed. In this case, the conversion results are always stored in the storage register ADREG08. After the conversion result is stored, EOCF changes to "1."

With <ITM[1:0]> set to "01," an interrupt request is generated each time four A/D conversion are completed. In this case, the conversion results are sequentially stored in storage registers ADREG08 through ADREG3B. After the conversion results are stored in ADREG3B, <EOCF> is set to "1," and the storage of subsequent conversion results starts from ADREG08. <EOCF> is cleared to "0" upon read.

With <ITM[1:0]> set to "10," an interrupt request is generated each time eight A/D conversions are completed. In this case, the conversion results are sequentially stored in storage registers ADREG08 through ADREG7F. After the conversion results are stored in ADREG7F, <EOCF> is set to "1," and the storage of subsequent conversion results starts from ADREG08.

<EOCF> is cleared to "0" upon read.

### 4. Channel scan repeat conversion mode

If ADMOD0 <REPEAT, SCAN> is set to "11," A/D conversion is performed in the channel scan repeat conversion mode.

In this mode, A/D conversion is performed repeatedly for a scan channel selected. Each time one A/D scan conversion is completed, ADMOD0 <EOCF> is set to "1," and the interrupt request INTAD is generated. ADMOD0 <ADBF> is not cleared to "0." It remains at "1." <EOCF> is cleared to "0" upon read.

To stop the A/D conversion operation in the repeat conversion mode (modes described in 3. and 4. above), write "0" to ADMOD0 <REPEAT>. When ongoing A/D conversion is completed, the repeat conversion mode terminates, and ADMOD0 <ADBF> is set to "0."

Before switching from one mode to standby mode (such standby modes as IDLE, STOP, etc.), check that A/D conversion is not being executed. If A/D conversion is under way, you must stop it or wait until it is completed.

#### (2) Top-priority A/D conversion

Top-priority A/D conversion is performed only in fixed channel single conversion mode. The ADMOD0<REPEAT, SCAN> setting has no relevance to the top-priority A/D conversion operations or preparations. As activation requirements are met, A/D conversion is performed only once for a channel designated by ADMOD2<HPADCH[3:0]>. After the A/D conversion is completed, the top-priority A/D conversion completion interrupt is generated, ADMOD2<EOCFHP> is set to "1," and <ADBFHP> returns to "0." The EOCFHP Flag is cleared upon read.

**Table 15-1 Relationships among A/D Conversion Modes, Interrupt Generation Timings and Flag Operations**

Conversion mode	Interrupt generation timing	EOCF setting timing (see Note)	ADBF (after the interrupt is generated)	ADMODO		
				ITM1: 0	REPEAT	SCAN
Fixed channel single conversion	After conversion is completed	After conversion is completed	0	—	0	0
Fixed channel repeat conversion	Each time one conversion is completed	After one conversion is completed	1	00	1	0
	Each time four conversions are completed	After four conversions are completed	1	01		
	Each time eight conversions are completed	After eight conversions are completed	1	10		
Channel scan single conversion	After scan conversion is completed	After scan conversion is completed	0	—	0	1
Channel scan repeat conversion	Each time one scan conversion is completed	After one scan conversion is completed	1	—	1	1

**(Note) EOCF is cleared upon read.**

## 15.5 High-priority Conversion Mode

By interrupting ongoing normal A/D conversion, top-priority A/D conversion can be performed. Top-priority A/D conversion can be software activated by setting  $ADMOD2\langle HPADCE \rangle$  to "1" or it can be activated using the HW resource by setting  $ADMOD3\langle [7:6] \rangle$  to an appropriate setting. If top-priority A/D conversion has been activated during normal A/D conversion, ongoing normal A/D conversion is interrupted, and single conversion is performed for a channel designated by  $ADMOD2\langle [3:0] \rangle$ . The result of single conversion is stored in ADREGSP, and the top-priority A/D conversion interrupt is generated. After top-priority A/D conversion is completed, normal A/D conversion is resumed; the status of normal A/D conversion immediately before being interrupted is maintained. Top-priority A/D conversion activated while top-priority A/D conversion is under way is ignored.

For example, if channel repeat conversion is activated for channels AN0 through AN8 and if  $\langle HPADCE \rangle$  is set to "1" during AN3 conversion, AN3 conversion is suspended, and conversion is performed for a channel designated by  $\langle HPADC[3:0] \rangle$ . After the result of conversion is stored in ADREGSP, channel repeat conversion is resumed, starting from AN3.

## 15.6 A/D Monitor Function

If  $ADCMPx\langle ADOBSVx \rangle$  is set to "1," the A/D monitor function is enabled. If the value of the conversion result storage register specified by  $REGS\langle [3:0] \rangle$  becomes larger or smaller ("larger" or "smaller" to be designated by  $ADOBIC$ ) than the value of a comparison register, the A/D monitor function interrupt is generated. This comparison operation is performed each time a result is stored in a corresponding conversion result storage register, and the interrupt is generated if the conditions are met. Because storage registers assigned to perform the A/D monitor function are usually not read by software, overrun flag  $\langle OVRn \rangle$  is always set and the conversion result storage flag  $\langle ADRnRF \rangle$  is also set. To use the A/D monitor function, therefore, a flag of a corresponding conversion result storage register must not be used.

## 15.7 Storing and Reading A/D Conversion Results

A/D conversion results are stored in upper and lower A/D conversion result registers for normal A/D conversion (ADREG08H/L through ADRG7FH/L).

In fixed channel repeat conversion mode, A/D conversion results are sequentially stored in ADREG08H/L through ADREG7FH/L. If  $\langle ITM1:0 \rangle$  is so set as to generate the interrupt each time one A/D conversion is completed, conversion results are stored only in ADREG08H/L. If  $\langle ITM[1:0] \rangle$  is so set as to generate the interrupt each time four A/D conversions are completed, conversion results are sequentially stored in ADREG08H/L through ADREG3BH/L.

Table 15-2 shows analog input channels and related A/D conversion result registers.

Table 15-2 Analog Input Channels and Related A/D Conversion Result Registers

Analog input channel (port A)	A/D conversion result register			
	Conversion modes other than shown to the right	Fixed channel repeat conversion mode (every one conversion)	Fixed channel repeat conversion mode (every four conversions)	Fixed channel repeat conversion mode (every eight conversions)
AN0	ADREG08H/L	ADREG08H/L fixed		
AN1	ADREG19H/L			
AN2	ADREG2AH/L			
AN3	ADREG3BH/L			
AN4	ADREG4CH/L			
AN5	ADREG5DH/L			
AN6	ADREG6EH/L			
AN7	ADREG7FH/L			
AN8	ADREG08H/L			
AN9	ADREG19H/L			
AN10	ADREG2AH/L			
AN11	ADREG3BH/L			
AN12	ADREG4CH/L			

## 15.8 Data Polling

To process A/D conversion results without using interrupts,  $ADMOD0<EOCF>$  must be polled. If this flag is set, conversion results are stored in a specified A/D conversion result register. After confirming that this flag is set, read that conversion result storage register. In reading the register, make sure that you first read upper bits and then lower bits to detect an overrun. If  $OVRn$  is "0" and  $ADRnRF$  is "1" in lower bits, a correct conversion result has been obtained.

## 16 Watchdog Timer (Runaway Detection Timer)

The watchdog timer (WDT) is for detecting malfunctions (runaways) of the CPU caused by noises or other disturbances and remedying them to return the CPU to normal operation. If the timer detects a runaway, it generates a non-maskable interrupt to notify the CPU and outputs "0" from the output pin of the watchdog timer ( $\overline{\text{WDTOUT}}$ ) to notify peripherals.

**(Note)** The TMPM330 does not include a watchdog timer out pin ( $\overline{\text{WDTOUT}}$ ).

The watchdog timer can reset the CPU by connecting the  $\overline{\text{WDTOUT}}$  pin to internal reset.

### 16.1 Configuration

Fig. 16-1 shows the block diagram of the watchdog timer

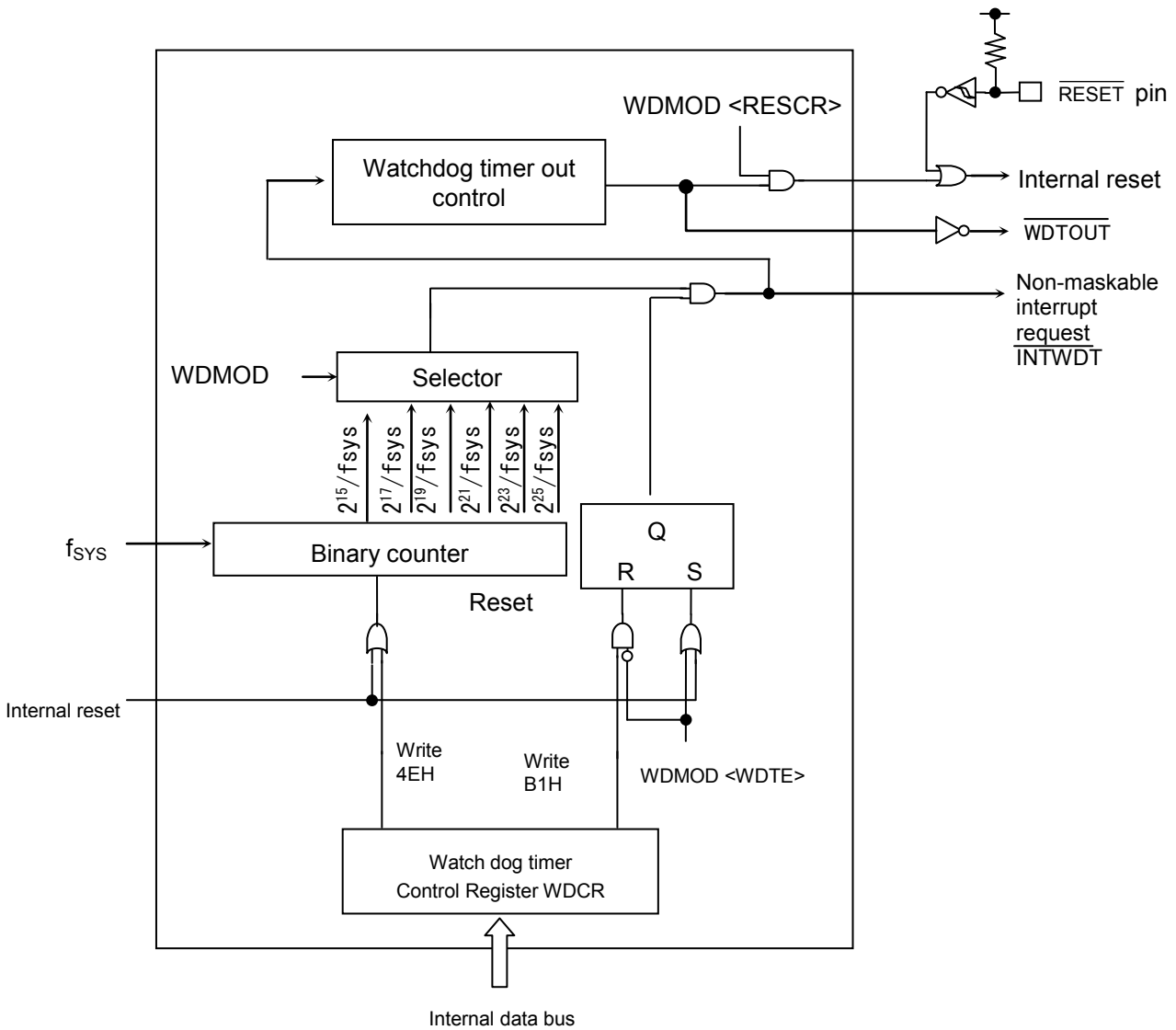

**Fig. 16-1 Block Diagram of the Watchdog Timer**

### 16.2 Watchdog Timer Interrupt

The watchdog timer consists of the binary counters that work using the  $f_{SYS}$  system clock as an input clock. The outputs produced by these binary counters are  $2^{15}$ ,  $2^{17}$ ,  $2^{19}$ ,  $2^{21}$ ,  $2^{23}$  and  $2^{25}$ . By selecting one of these outputs with  $WDMOD <WDTP[2:0]>$ , a watchdog timer interrupt  $\overline{INTWDT}$  can be generated and the  $\overline{WDTOUT}$  is output when an overflow occurs, as shown in Fig. 16-2.

The  $\overline{INTWDT}$  interrupt is one of the non-maskable interrupt factors. The  $\overline{INTWDT}$  interrupt can be identified with the  $NMIFLG <NMIFLG0>$  bit in the clock generator

The output pin of the watchdog timer can reset the peripherals by outputting “0” caused by an overflow. The output is set to “1” if the watchdog timer is cleared (if the clear code 4EH is written to the WDCR register). The  $\overline{WDTOUT}$  pin outputs “0” at normal mode unless the clear code is written to WDCR register.

**(Note)** The TMPM330 does not include a watchdog timer out pin ( $\overline{WDTOUT}$ ).

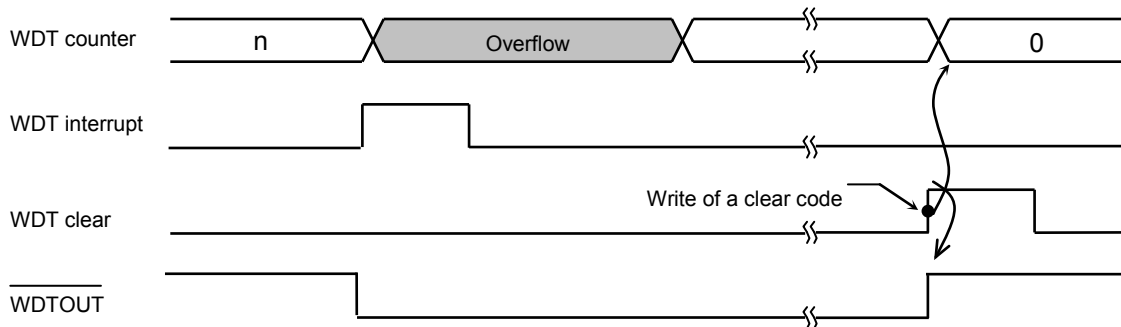

**Fig. 16-2 Normal Mode**

When an overflow occurs, resetting the chip itself is an option to choose. If the chip is reset, a reset is affected for a 32-state time, as shown in Fig. 16-3. If this reset is affected, the clock  $f_{SYS}$  that the clock gear generates by dividing the clock  $f_C$  of the high-speed oscillator by 1 is used as an input clock  $f_{SYS}$ .

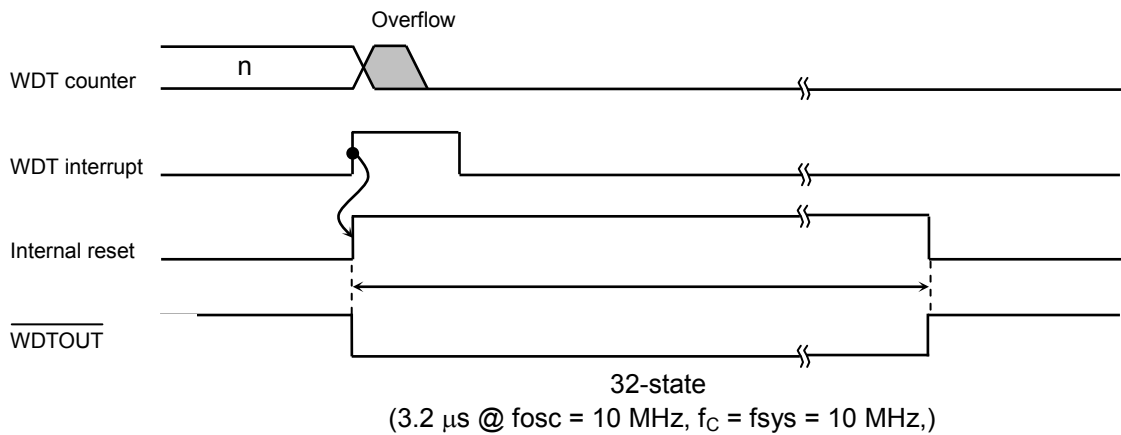

**Fig. 16-3 Reset Mode**

## 16.3 Control Registers

The watchdog timer (WDT) is controlled by two control registers WDMOD and WDCR.

### 16.3.1 Watchdog Timer Mode Register (WDMOD)

1. Specifying the detection time of the watchdog timer <WDTP[2:0]>

This is a 2-bit register for specifying the watchdog timer interrupt time for runaway detection. When a reset is effected, this register is initialized to WDMOD <WDTP[2:0]> = "000." Fig. 16-4 shows the detection time of the watchdog timer.

2. Enabling/disabling the watchdog timer <WDTE>

When resetting, WDMOD <WDTE> is initialized to "1" and the watchdog timer is enabled.

To disable the watchdog timer, this bit must be set to "0" and, at the same time, the disable code (B1H) must be written to the WDCR register. This dual setting is intended to minimize the probability that the watchdog timer may inadvertently be disabled if a runaway occurs.

To change the status of the watchdog timer from "disable" to "enable," set the <WDTE> bit to "1".

3. Watchdog timer out reset connection <RESCR>

Setting this bit to "1" enables the watch dog timer to be reset when a runaway is detected. Since a reset initializes this bit to "1," a counter overflow causes a reset.

### 16.3.2 Watchdog Timer Control Register (WDCR)

This is a register for disabling the watchdog timer function and controlling the clearing function of the binary counter.

- Disabling control

By writing the disable code (B1H) to this WDCR register after setting WDMOD <WDTE> to "0," the watchdog timer can be disabled.

WDMOD	← 0 - - - - -	Clears WDTE to "0."
WDCR	← 1 0 1 1 0 0 0 1	Writes the disable code (B1H).

- Enabling control

Set WDMOD <WDTE> to "1".

- Watchdog timer clearing control

Writing the clear code (4EH) to the WDCR register clears the binary counter and allows it to resume counting.

WDCR	← 0 1 0 0 1 1 1 0	Writes the clear code (4EH)
------	-------------------	-----------------------------

<b>(Note) Writing the disable code (BIH) clears the binary counter.</b>
---

Watchdog Timer Mode Register

WDMOD  
(0x4004\_0000)

	7	6	5	4	3	2	1	0
bit Symbol	WDTE	WDTP2	WDTP1	WDTP0		I2WDT	RESCR	
Read/Write	R/W	R/W			R	R/W		R/W
After reset	1	0	0	0		0	1	0
Function	WDT control 1: enable	Selects WDT detection time 000: $2^{15}/f_{SYS}$ 001: $2^{17}/f_{SYS}$ 010: $2^{19}/f_{SYS}$ 011: $2^{21}/f_{SYS}$ 100: $2^{23}/f_{SYS}$ 101: $2^{25}/f_{SYS}$ 110: Setting prohibited 111: Setting prohibited			"0" is read.	IDLE 0: Stop 1: Start	0: Generates NMI interrupt 1: Connects WDTOUT to reset	Write "0."

Watchdog timer out control

0	Generates NMI interrupt
1	Connects WDT out to reset

Detection time of watchdog timer

@ fc = 40 MHz

SYSCR1 clock gear value <GEAR[2:0]>	Detection time of watchdog timer						
	WDMOD<WDTP[2:0]>						
	000	001	010	011	100	101	
000 (fc)	0.82 ms	3.28 ms	13.11 ms	52.43 ms	209.72 ms	838.86 ms	
100 (fc/2)	1.63 ms	6.55 ms	26.21 ms	104.86 ms	419.43 ms	1.68 s	
101 (fc/4)	3.28 ms	13.11 ms	52.43 ms	209.72 ms	838.86 ms	3.36 s	
110 (fc/8)	6.55 ms	26.21 ms	104.86 ms	419.43 ms	1.68 s	6.71 s	

Enable/disable control of the watchdog timer

0	Disable
1	Enable

Watchdog Timer Control Register

WDCR  
(0x4004\_0004)

	7	6	5	4	3	2	1	0
bit Symbol	—							
Read/Write	W							
After reset	—							
Function	B1H : WDT disable code 4EH : WDT clear code							

Disable & clear of WDT

B1H	WDT disable code
4EH	WDT clear code
Others	—

Fig. 16-4 Watchdog Timer Registers

### 16.4 Control Register

The watchdog timer generates the  $\overline{\text{INTWDT}}$  interrupt after a lapse of the detection time specified by the WDMOD <WDTP[2:0]> register and outputs a signal at low level from the output pin of the watchdog timer ( $\overline{\text{WDTOUT}}$ ). Before generating the  $\overline{\text{INTWDT}}$  interrupt, the binary counter for the watchdog timer must be cleared to "0" using software (instruction). If the CPU malfunctions (runaways) due to noise or other disturbances and cannot execute the instruction to clear the binary counter, the binary counter overflows and the non-maskable interrupt is generated by the  $\overline{\text{INTWDT}}$  interrupt. The CPU is able to recognize the occurrence of a malfunction (runaway) by identifying the non-maskable interrupt and to restore the faulty condition to normal by using a malfunction (runaway) countermeasure program. Additionally, it is possible to resolve the problem of a malfunction (runaway) of the CPU by connecting the watchdog timer out pin to reset pins of peripheral devices.

**(Note)** The TMPM330 does not include a watchdog timer out pin ( $\overline{\text{WDTOUT}}$ ).

The watchdog timer begins operation immediately after a reset is cleared.

In STOP mode, the watchdog timer is reset and in an idle state. When the bus is released ( $\overline{\text{BUSAK}} = \text{"L"}$ ), it continues counting. In IDLE mode, its operation depends on the WDMOD <I2WDT> setting. Before putting it in IDLE mode, WDMOD <I2WDT> must be set to an appropriate setting, as required.

**(Note)** Releasing bus is disabled since no external bus feature is available on the TMPM330.

Example:

1. To clear the binary counter

```

      7 6 5 4 3 2 1 0
WDCR ← 0 1 0 0 1 1 1 0    Writes the clear code (4EH)
    
```

2. To set the detection time of the watchdog timer to  $2^{21}/f_{\text{SYS}}$ .

```

      7 6 5 4 3 2 1 0
WDMOD ← 1 0 1 1 - - - (
    
```

3. To disable the watchdog timer.

```

      7 6 5 4 3 2 1 0
WDMOD ( 0 ( ( ( ( ( ( (
WDCR  ( 1 0 1 1 0 0 0 1    Clears WDTE to "0"
                                   Writes the disable code (B1H)
    
```

**(Note 1)** If the watchdog timer is operated when the high-frequency oscillator is idle, the system reset operation initiated by the watchdog timer becomes erratic due to the unstable oscillation of the high-frequency oscillator. Therefore, do not operate the watchdog timer when the high-frequency oscillator is idle.

**(Note 2)** The counter of the watchdog timer stops at the debug mode.

## 17 Real Time Clock (RTC)

### 17.1 Functions

- 1) Clock (hour, minute and second)
- 2) Calendar (month, week, date and leap year)
- 3) Selectable 12 (am/ pm) and 24 hour display
- 4) Time adjustment + or - 30 seconds (by software)
- 5) Alarm (alarm output)
- 6) Alarm interrupt

### 17.2 Block Diagram

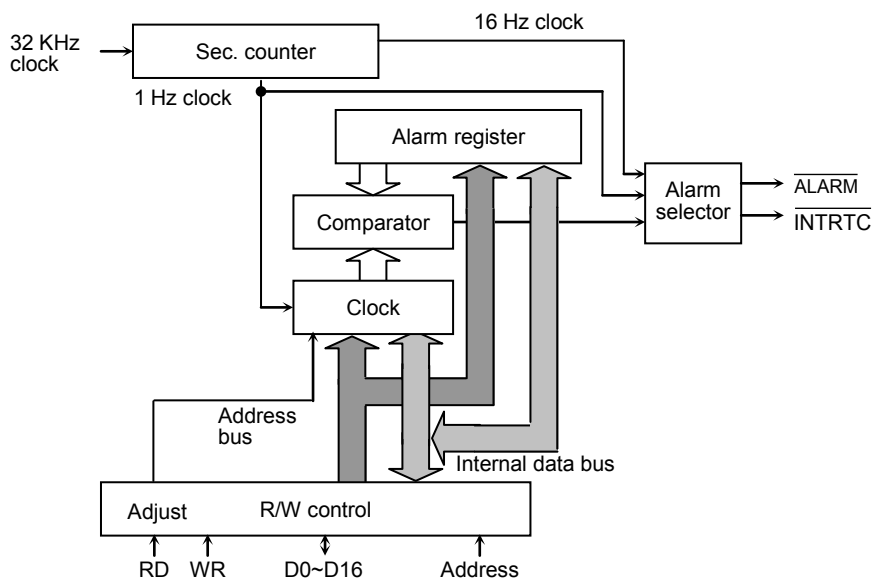

Fig. 17-1 Block Diagram

**(Note 1) Western calendar year column:**

This product uses only the final two digits of the year. The year following 99 is 00 years. Please take into account the first two digits when handling years in the western calendar.

**(Note 2) Leap year:**

A leap year is divisible by 4 excluding a year divisible by 100; the year divisible by 100 is not considered to be a leap year. Any year divisible by 400 is a leap year. This product is considered the year divisible by 4 to be a leap year and does not take into account the above exceptions. It needs adjustments for the exceptions.

### 17.3 Control Registers

Reset operation initializes the following registers:

- PAGER<PAGE>,<ADJUST>,<INTENA>
- RESTR<RSTALM>,<RSTTMR>,<DIS16HZ>,<DIS1HZ>

Other clock-related registers are not initialized by reset operation.

Before starting the RTC, set the time, month, day, day of the week, year and leap year in the relevant registers.

Caution is required in setting clock data, adjusting seconds or resetting the clock. Refer to “17.5.3 Entering the Low Power Consumption Mode”.

Table 17-1 PAGE0 (clock function) register

Symbol	Address	Bit7	Bit6	Bit5	Bit4	Bit3	Bit2	Bit1	Bit0	Function	Read/Write
SECR	0x4004_0100H	/	40 sec	20 sec	10 sec	8 sec	4 sec	2 sec	1 sec	Second column	R/W
MINR	0x4004_0101H	/	40 min	20 min	10 min	8 min	4 min	2 min	1 min	Minute column	R/W
HOURL	0x4004_0102H	/	/	20 hours /PM/AM	10 hours	8 hours	4 hours	2 hours	1 hours	Hour column	R/W
DAYR	0x4004_0104H	/	/	/	/	/	W2	W1	W0	Day of the week column	R/W
DATER	0x4004_0105H	/	/	Day 20	Day 10	Day 8	Day 4	Day 2	Day 1	Day column	R/W
MONTHR	0x4004_0106H	/	/	/	Oct.	Aug.	Apr.	Feb.	Jan.	Month column	R/W
YEARR	0x4004_0107H	Year 80	Year 40	Year 20	Year 10	Year 8	Year 4	Year 2	Year 1	Year column (lower two columns)	R/W
PAGER	0x4004_0108H	Interrupt enable	/	/	Adjustment function	Clock enable	Alarm enable	/	PAGE setting	PAGE register	W, R/W
RESTR	0x4004_010CH	1Hz enable	16Hz enable	Clock reset	Alarm reset	Always write “0”.				Reset register	W only

**(Note) Reading SECR, MINR, HOURL, DAYR, MONTHR, YEARR of PAGE0 captures the current state.**

Table 17-2 PAGE1 (alarm function) registers

Symbol	Address	Bit7	Bit6	Bit5	Bit4	Bit3	Bit2	Bit1	Bit0	Function	Read/Write
SECR	0x4004_0100H	/	/	/	/	/	/	/	/	/	/
MINR	0x4004_0101H	/	40 min	20 min	10 min	8 min	4 min	2 min	1 min	Minute column	R/W
HOURL	0x4004_0102H	/	/	20 hours /PM/AM	10 hours	8 hours	4 hours	2 hours	1 hour	Hour column	R/W
DAYR	0x4004_0104H	/	/	/	/	/	W2	W1	W0	Day of the week column	R/W
DATER	0x4004_0105H	/	/	Day 20	Day 10	Day 8	Day 4	Day 2	Day 1	Day column	R/W
MONTHR	0x4004_0106H	/	/	/	/	/	/	/	24/12	24-hour clock mode	R/W
YEARR	0x4004_0107H	/	/	/	/	/	/	Leap-year setting		Leap-year mode	R/W
PAGER	0x4004_0108H	Interrupt enable	/	/	Adjustment function	Clock enable	Alarm enable	/	PAGE setting	PAGE register	W,R/W
RESTR	0x4004_010CH	1Hz enable	16Hz enable	Clock reset	Alarm reset	Always write “0”.				Reset register	W only

**(Note 1) Reading SECR, MINR, HOURL, DAYR, MONTHR, YEARR of PAGE1 captures the current state.**

**(Note 2) SECR, MINR, HOURL, DAYR, MONTHR, YEARR of PAGE0 and YEARR of PAGE1 (for leap year) must be read twice and compare the data captured.**

### 17.4 Detailed Description of Control Register

The RTC is not initialized by system reset. All registers must be initialized at the beginning of the program.

(1) Second column register (for PAGE0 only)

	7	6	5	4	3	2	1	0	
SECR	Bit symbol	—	SE6	SE5	SE4	SE3	SE2	SE1	SE0
	Read/Write	R	R/W						
	After reset	0	Undefined						
	Function	"0" is read.	40 sec. column	20 sec. column	10 sec. column	8 sec. column	4 sec. column	2 sec. column	1 sec. column

0	0	0	0	0	0	0	0	0 sec
0	0	0	0	0	0	0	1	1 sec
0	0	0	0	0	0	1	0	2 sec
0	0	0	0	0	0	1	1	3 sec
0	0	0	0	0	1	0	0	4 sec
0	0	0	0	0	1	0	1	5 sec
0	0	0	0	0	1	1	0	6 sec
0	0	0	0	0	1	1	1	7 sec
0	0	0	1	0	0	0	0	8 sec
0	0	0	1	0	0	0	1	9 sec
0	0	1	0	0	0	0	0	10 sec
:								
0	0	1	1	0	0	1	1	19 sec
0	1	0	0	0	0	0	0	20 sec
:								
0	1	0	1	0	0	1	1	29 sec
0	1	1	0	0	0	0	0	30 sec
:								
0	1	1	1	0	0	1	1	39 sec
1	0	0	0	0	0	0	0	40 sec
:								
1	0	0	1	0	0	1	1	49 sec
1	0	1	0	0	0	0	0	50 sec
:								
1	0	1	1	0	0	1	1	59 sec

Note) The setting other than listed above is prohibited.

(2) Minute column register (for PAGE0/1)

	7	6	5	4	3	2	1	0	
MINR	Bit symbol	—	MI6	MI5	MI4	MI3	MI2	MI1	MI0
	Read/Write	R	R/W						
	After reset	0	Undefined						
	Function	"0" is read	40 min. column	20 min. column	10 min. column	8 min. column	4 min. column	2 min. column	1 min. column

0	0	0	0	0	0	0	0	0 min
0	0	0	0	0	0	0	1	1 min
0	0	0	0	0	0	1	0	2 min
0	0	0	0	0	0	1	1	3 min
0	0	0	0	0	1	0	0	4 min
0	0	0	0	0	1	0	1	5 min
0	0	0	0	0	1	1	0	6 min
0	0	0	0	0	1	1	1	7 min
0	0	0	0	1	0	0	0	8 min
0	0	0	0	1	0	0	1	9 min
0	0	1	0	0	0	0	0	10 min
:								
0	0	1	1	0	0	0	1	19 min
0	1	0	0	0	0	0	0	20 min
:								
0	1	0	1	0	0	0	1	29 min
0	1	1	0	0	0	0	0	30 min
:								
0	1	1	1	0	0	0	1	39 min
1	0	0	0	0	0	0	0	40 min
:								
1	0	0	1	0	0	0	1	49 min
1	0	1	0	0	0	0	0	50 min
:								
1	0	1	1	0	0	0	1	59 min

Note) The setting other than listed above is prohibited.

(3) Hour column register (for PAGE0/1)

1. 24-hour clock mode (MONTHR<MO0>="1")

	7	6	5	4	3	2	1	0
Bit symbol	—		HO5	HO4	HO3	HO2	HO1	HO0
Read/Write	R		R/W					
After reset	0		Undefined					
Function	"0" is read.		20 hour column	10 hour column	8 hour column	4 hour column	2 hour column	1 hour column

0	0	0	0	0	0	0	0 o' clock
0	0	0	0	0	0	1	1 o' clock
0	0	0	0	0	1	0	2 o' clock
:							
0	0	1	0	0	0	0	8 o' clock
0	0	1	0	0	0	1	9 o' clock
0	1	0	0	0	0	0	10 o' clock
:							
0	1	1	0	0	0	1	19 o' clock
1	0	0	0	0	0	0	20 o' clock
:							
1	0	0	0	0	1	1	23 o' clock

Note) The setting other than listed above is prohibited.

2. 12-hour clock mode (MONTHR<MO0>="0")

	7	6	5	4	3	2	1	0
Bit symbol	—		HO5	HO4	HO3	HO2	HO1	HO0
Read/Write	R		R/W					
After reset	0		Undefined					
Function	"0" is read.		PM/AM	10 hour column	8 hour column	4 hour column	2 hour column	1 hour column

0	0	0	0	0	0	0	0 o' clock (AM)
0	0	0	0	0	0	1	1 o' clock
0	0	0	0	0	1	0	2 o' clock
:							
0	0	1	0	0	0	1	9 o' clock
0	1	0	0	0	0	0	10 o' clock
0	1	0	0	0	0	1	11 o' clock
1	0	0	0	0	0	0	0 o' clock (PM)
1	0	0	0	0	0	1	1 o' clock

Note) The setting other than listed above is prohibited.

(4) Day of the week column register (for PAGE0/1)

	7	6	5	4	3	2	1	0
DAYR	—					WE2	WE1	WE0
Bit symbol	—					WE2	WE1	WE0
Read/Write	R					R/W		
After reset	0					Undefined		
Function	"0" is read.					W2	W1	W0

0	0	0	Sunday
0	0	1	Monday
0	1	0	Tuesday
0	1	1	Wednesday
1	0	0	Thursday
1	0	1	Friday
1	1	0	Saturday

Note) The setting other than listed above is prohibited.

(5) Day column register (PAGE0/1)

	7	6	5	4	3	2	1	0
DATER	—		DA5	DA4	DA3	DA2	DA1	DA0
Bit symbol	—		DA5	DA4	DA3	DA2	DA1	DA0
Read/Write	R		R/W					
After reset	0		Undefined					
Function	"0" is read.		Day 20	Day 10	Day 8	Day 4	Day 2	Day 1

0	0	0	0	0	0	0	0
0	0	0	0	0	0	1	1st day
0	0	0	0	0	1	0	2nd day
0	0	0	0	0	1	1	3rd day
0	0	0	1	0	0	0	4th day
:							
0	0	1	0	0	1	1	9th day
0	1	0	0	0	0	0	10th day
0	1	0	0	0	0	1	11th day
:							
0	1	1	0	0	1	1	19th day
1	0	0	0	0	0	0	20th day
:							
1	0	1	0	0	1	1	29th day
1	1	0	0	0	0	0	30th day
1	1	0	0	0	0	1	31st day

Note 1) The setting other than listed above is prohibited.

Note 2) Do not set for non-existent days (e.g.: 30th Feb)

(6) Month column register (for PAGE0 only)

	7	6	5	4	3	2	1	0
MONTHR	—			MO4	MO4	MO2	MO1	MO0
Bit symbol	—			MO4	MO4	MO2	MO1	MO0
Read/Write	R			R/W				
After reset	0			Undefined				
Function	"0" is read.			10 months	8 months	4 months	2 months	1 month

0	0	0	0	1	January
0	0	0	1	0	February
0	0	0	1	1	March
0	0	1	0	0	April
0	0	1	0	1	May
0	0	1	1	0	June
0	0	1	1	1	July
0	1	0	0	0	August
0	1	0	0	1	September
1	0	0	0	0	October
1	0	0	0	1	November
1	0	0	1	0	December

Note) The setting other than listed above is prohibited.

(7) Selection of 24-hour clock or 12-hour clock (for PAGE1 only)

	7	6	5	4	3	2	1	0
MONTHR	—							MO0
Bit symbol	—							MO0
Read/Write	R							R/W
After reset	0							Undefined
Function	"0" is read.							1: 24-hour 0: 12-hour

**(Note) Do not change the MONTHR<MO0> bit while the RTC is in operation.**

(8) Year column register (for PAGE0 only)

	7	6	5	4	3	2	1	0	
YEARR	Bit symbol	YE7	YE6	YE5	YE4	YE3	YE2	YE1	YE0
	Read/Write	R/W							
	After reset	Undefined							
	Function	80 years	40 years	20 years	10 years	8 years	4 years	2 years	1 year

0	0	0	0	0	0	0	0	00
0	0	0	0	0	0	0	1	01 years
0	0	0	0	0	0	1	0	02 years
0	0	0	0	0	0	1	1	03 years
0	0	0	0	0	1	0	0	04 years
0	0	0	0	0	1	0	1	05 years
:								
1	0	0	1	1	0	0	1	99 years

Note) The setting other than listed above is prohibited.

(9) Leap year register (for PAGE1 only)

	7	6	5	4	3	2	1	0
YEARR	—						LEAP1	LEAP0
	R						R/W	
	0						Undefined	
	"0" is read.						00: leap year 01: one year after leap year 10: two years after leap year 11: three years after leap year	

0	0	Current year is a leap-year.
0	1	Current year is the year following a leap-year.
1	0	Current year is two years after a leap year.
1	1	Current year is three years after a leap year

(10) PAGE register (for PAGE0/1)

	7	6	5	4	3	2	1	0
PAGER	Bit symbol	INTENA	—	ADJUST	ENATMR	ENAALM	—	PAGE
	Read/Write	R/W	R	R/W	R/W		R	R/W
	After reset	0	0	0	Undefined		0	0
A read-modify-write operation cannot be performed.	Function	INTRTC 0: Disabled 1: Enabled	"0" is read.	[Write] 0: Don't care 1: Sets ADJUST request [Read] 0: No ADJUST request 1: ADJUST requested	Clock 0: Disabled 1: Enabled	ALARM 0: Disabled 1: Enabled	"0" is read.	PAGE selection

**(Note1)**A read-modify-write operation cannot be performed.  
**(Note2)**To set interrupt enable bits to <ENATMR>, <ENAALM>and<INTENA>, you must follow the order specified here. Make sure not to set them at the same time(make sure that there is time lag between interrupt enable and clock/alarm enable). To change the setting of <ENATMR>, <ENAALM> and <INTENA> must be disabled first.

Example: Clock setting/Alarm setting

7 6 5 4 3 2 1 0  
PAGER ← 0 0 0 0 1 1 0 0 Enables Clock and alarm  
PAGER ← 1 0 0 0 1 1 0 0 Enables interrupt

PAGE	0	Selects Page0
	1	Selects Page1

ADJUST	0	Don't care
	1	Adjusts seconds. The request is sampled when the sec. counter counts up. If the time elapsed is between 0 and 29 seconds, the sec. counter is cleared to "0". If the time elapsed is between 30 and 59 seconds, the min. counter is carried and sec. counter is cleared to "0". Reading this bit shows if ADJUST is requested or not.

(11) Reset register (for PAGE0/1)

	7	6	5	4	3	2	1	0
RESTR	Bit symbol	DIS1HZ	DIS16HZ	RSTTMR	RSTALM	-		
	Read/Write	R/W				R		
	After reset	1	1	0	0	0		
A read-modify-write operation cannot be performed.	Function	1 Hz 0: Enabled 1: Disabled	16 Hz 0: Enabled 1: Disabled	[Write] 0: Don't care 1: Clock reset [Read] 0: No RESET request 1: RESET request ed	0: Don't care 1: Alarm reset	"0" is read.		

**(Note) A read-modify-write operation cannot be performed.**

RSTALM	0	Unused
	1	Initializes alarm registers (Minute Column, Hour Column, Day Column and Day of the week Column) as follows. Minute: 00, Hour: 00, Day: 01, Day of the week: Sunday
RSTTMR	0	Unused
	1	Resets sec counter. Reading this bit shows if RESET is requested or not. The request is sampled using low-speed clock.

The setting of <DIS1HZ> and <DIS16MHZ>,RTCPAGER<ENAALM> used for alarm, 1Hz interrupt and 16Hz interrupt is shown as below.

<DIS1HZ>	<DIS16MHZ>	PAGER<ENAALM>	Interrupt source signal
1	1	1	Alarm
0	1	0	1Hz
1	0	0	16Hz
Others			Outputs "0".

## 17.5 Operational Description

The RTC incorporates a sec. counter that generates a 1Hz signal from a 32.768 KHz signal. The sec. counter operation must be taken into account when using the RTC.

### 17.5.1 Reading clock data

#### 1. Using 1Hz interrupt

The 1Hz interrupt is generated being synchronized with counting up of the sec. counter. Data can be read correctly if reading data after 1Hz interrupt occurred.

#### 2. Using pair reading

There is a possibility that the clock data may be read incorrectly if the internal counter operates carry during reading. To ensure correct data reading, read the clock data twice as shown below. A pair of data read successively needs to match.

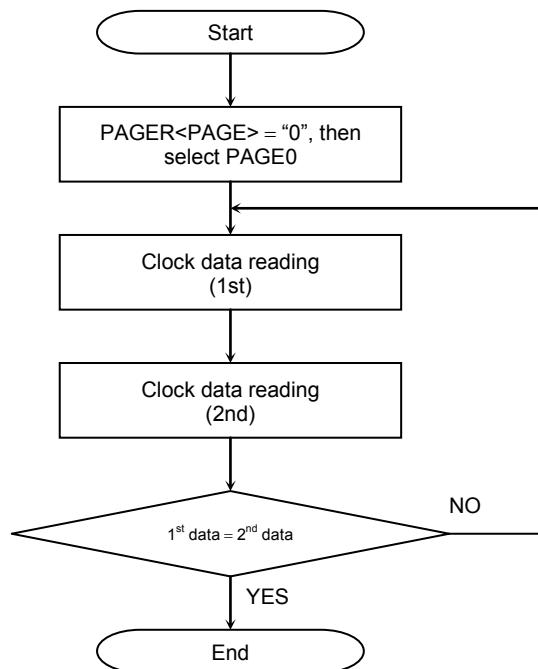

Fig. 17-2 Flowchart of the clock data reading

### 17.5.2 Writing clock data

A carry during writing ruins correct data writing. The following procedure ensures the correct data writing.

#### 1. Using 1Hz interrupt

The 1Hz interrupt is generated being synchronized with counting up of the sec. counter. If data is written in the time between 1Hz interrupt and subsequent one second count, it completes correctly.

#### 2. Resetting counter

Write data after resetting the sec. counter.

The 1Hz-interrupt is generated one second after enabling the interrupt subsequent to counter reset. The time must be set within one second after the interrupt.

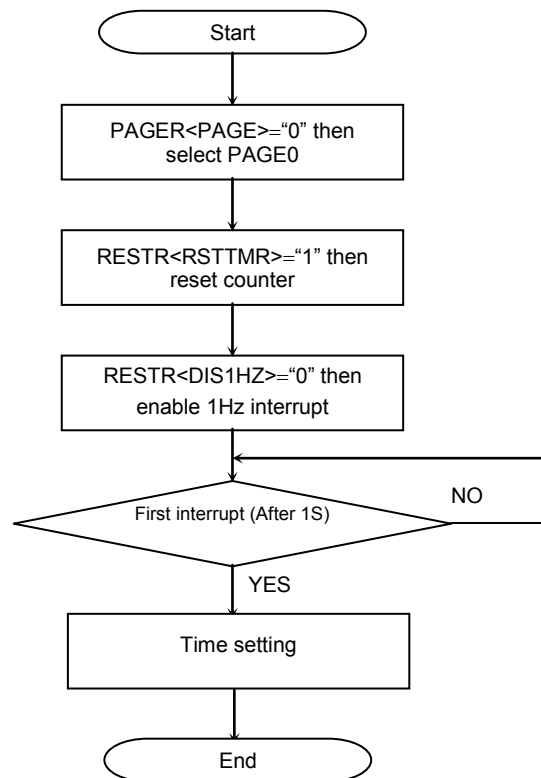

Fig. 17-3 Flowchart of the clock data writing

### 3. Disabling the clock

Writing "0" to PAGER<ENATMR> disables clock operation including a carry.

Stop the clock after the 1Hz-interrupt. The sec. counter keeps counting. Set the clock again and enable the clock within one second before next 1Hz-interrupt.

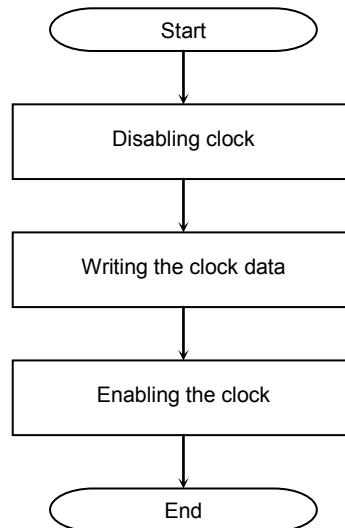

Fig. 17-4 Flowchart of the disabling clock

### 17.5.3 Entering the Low Power Consumption Mode

To enter SLEEP mode, in which the system clock stops, after changing clock data, adjusting seconds or resetting the clock, be sure to observe one of the following procedures:

1. After changing the clock setting registers, setting the PAGER<ADJUST> bit or setting the RESTR<RSTTMR> bit, wait for one second for an interrupt to be generated.
2. After changing the clock setting registers, setting the PAGER<ADJUST> bit or setting the RESTR<RSTTMR> bit, read the corresponding clock register values, <ADJUST> or <RSTTMR> to make sure that the setting you have made is reflected.

## 17.6 Alarm Function

By writing "1" to PAGER<PAGE>, the alarm function of the PAGE1 registers is enabled. One of the following three signals is output to the  $\overline{\text{ALARM}}$  pin.

- (1) "0" pulse (when the alarm register corresponds with the clock)
- (2) 1Hz cycle "0" pulse
- (3) 16Hz cycle "0" pulse

In any cases shown above, the INTRTC outputs one cycle pulse of low-speed clock. It outputs the INTRTC interrupt request simultaneously.

The INTRTC interrupt signal is falling edge triggered. Specify the falling edge as the active state in the CG Interrupt Mode Control Register.

- (1) "0" pulse (when the alarm register corresponds with the clock)

"0" pulse is output to the  $\overline{\text{ALARM}}$  pin when the values of the PAGE0 clock register and the PAGE1 alarm register correspond. The INTRTC interrupt is generated and the alarm is triggered.

### The alarm settings

Initialize the alarm with alarm prohibited. Write "1" to RESTR<RSTALM>. It makes the alarm setting to be 00 minute, 00 hour, 01 day and Sunday.

Setting alarm for min., hour, date and day is done by writing data to the relevant PAGE1 register. Enable the alarm with the PAGER <ENAALM> bit. Enable the interrupt with the PAGER <INTENA> bit.

The following is an example program for outputting an alarm from the  $\overline{\text{ALARM}}$  pin at noon (PM12:00) on Monday 5<sup>th</sup>.

	7	6	5	4	3	2	1	0		
PAGER	←	0	0	0	0	1	0	0	1	Disables alarm, sets PAGE1
RESTR	←	1	1	0	1	0	0	0	0	Initializes alarm
DAYR	←	0	0	0	0	0	0	0	1	Monday
DATAR	←	0	0	0	0	0	1	0	1	5th day
HOURR	←	0	0	0	1	0	0	1	0	Sets 12 o'clock
MINR	←	0	0	0	0	0	0	0	0	Sets 00 min.
PAGER	←	0	0	0	0	1	1	0	0	Enables alarm
PAGER	←	1	0	0	0	1	1	0	0	Enables interrupt

The above alarm works in synchronization with the low-speed clock. When the CPU is operating at high frequency oscillation, a maximum of one clock delay at 32 kHz (about 30μs) may occur for the time register setting to become valid.

**(Note)** To make the alarm work repeatedly (e.g. every Wednesday at 12:00), next alarm must be set during the INTRTC interrupt routine that is generated when the time set for the alarm matches the RTC count.

## (2) 1Hz cycle "0" pulse

The RTC outputs a "0" pulse cycle of low-speed 1Hz clock to the  $\overline{\text{ALARM}}$  pin by setting  $\text{PAGER<INTENA>}=1$  after setting  $\text{PAGER<ENAALM>}= "0"$ ,  $\text{RESTR<DIS1HZ>}= "0"$  and  $\text{<DIS16HZ>}= "1"$ . It generates an INTRTC interrupt simultaneously.

## (3) 16Hz cycle "0" pulse

The RTC outputs a "0" pulse cycle of low-speed 16Hz clock to the  $\overline{\text{ALARM}}$  pin by setting  $\text{PAGER<INTENA>}=1$  after setting  $\text{PAGER<ENAALM>}= "0"$ ,  $\text{RESTR<DIS1HZ>}= "1"$  and  $\text{<DIS16HZ>}= "0"$ . It generates an INTRTC interrupt simultaneously.

## 18 Flash Memory Operation

This section describes the hardware configuration and operation of the flash memory.

### 18.1 Flash Memory

#### 18.1.1 Features

1) Memory capacity

The TMPM330 device contains flash memory. The memory sizes and configurations are shown in the table below. Independent write access to each block is available. When the CPU is to access the internal flash memory, 32-bit data bus width is used.

2) Write/erase time

Writing is executed per page. The TMPM330 contains 128 words in a page.

Page writing requires 1.25ms (typical) regardless of number of words.

A block erase requires 0.1 sec. (typical).

The following table shows write and erase time per chip.

Product Name	Memory Size	Block Configuration				# of Words	Write Time	Erase Time
		128KB	64KB	32KB	16KB			
TMPM330FYWFG	256KB	1	1	2	-	128	0.64sec	0.4sec

**(Note) The above values are theoretical values not including data transfer time.**

**The write time per chip depends on the write method to be used by the user.**

3) Programming method

The onboard programming mode is available for the user to program (rewrite) the device while it is mounted on the user's board.

- The onboard programming mode

3-1) User boot mode

The user's original rewriting method can be supported.

3-2) Single boot mode

The rewriting method to use serial data transfer (Toshiba's unique method) can be supported.

4) Rewriting method

The flash memory included in this device is generally compliant with the applicable JEDEC standards except for some specific functions. Therefore, if the user is currently using an external flash memory device, it is easy to implement the functions into this device. Furthermore, the user is not required to build his/her own programs to realize complicated write and erase functions because such functions are automatically performed using the circuits already built-in the flash memory chip.

JEDEC compliant functions	Modified, added, or deleted functions
<ul style="list-style-type: none"> <li>• Automatic programming</li> <li>• Automatic chip erase</li> <li>• Automatic block erase</li> </ul>	<p>&lt;Modified&gt; Block protect (only software protection is supported)</p> <p>&lt;Deleted&gt; Erase resume - suspend function</p>
<ul style="list-style-type: none"> <li>• Data polling/toggle bit</li> </ul>	

5) Protect/Security Function

This device is also implemented with a read-protect function to inhibit reading flash memory data from any external writer device. On the other hand, rewrite protection is available only through command-based software programming; any hardware setting method to apply +12VDC is not supported. See chapter 19 for details of ROM protection and security function.

Note: If a password is set to 0xFF (erased data), it is difficult to protect data securely due to an easy-to-guess password. Even if Single Boot mode is not used, it is recommended to set a unique value as a password.

18.1.2 Block Diagram of the Flash Memory Section

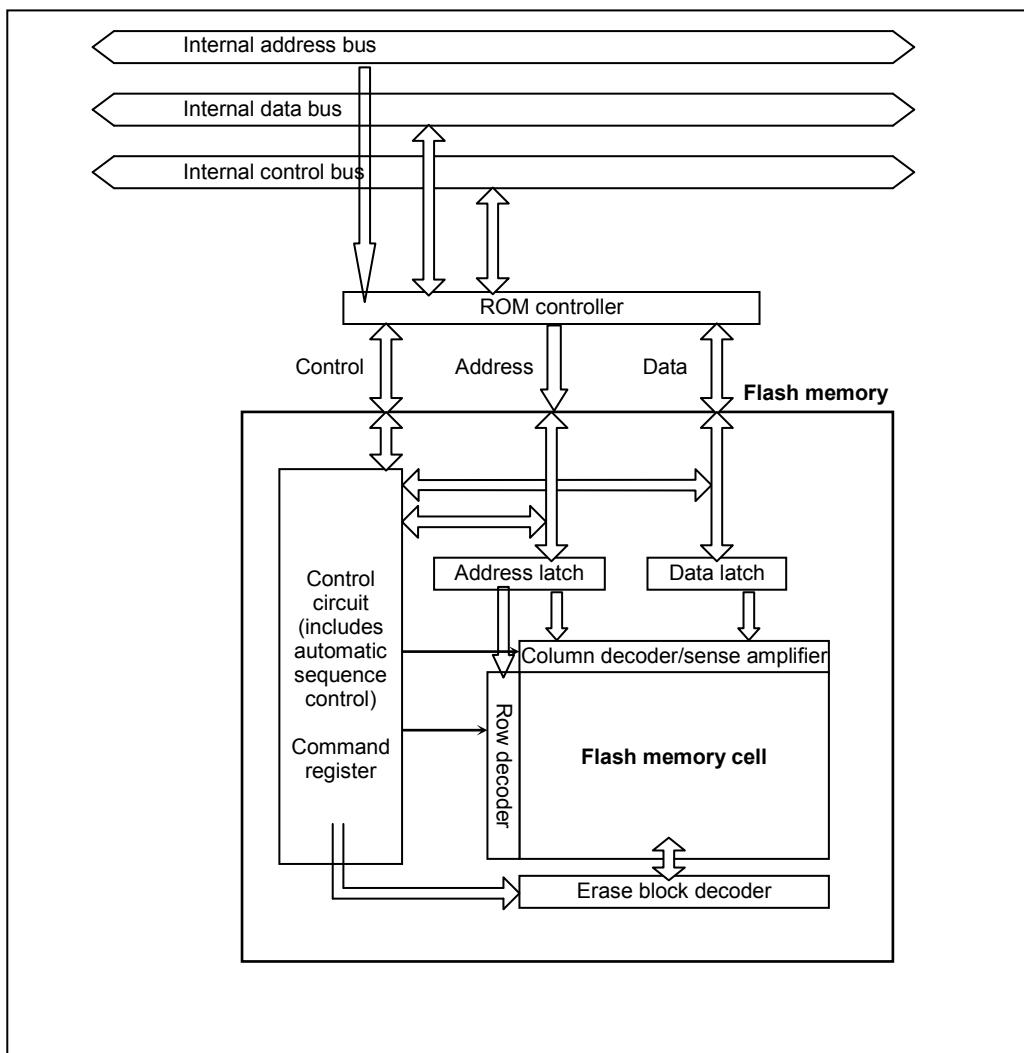

Fig. 18-1 Block Diagram of the Flash Memory Section

## 18.2 Operation Mode

This device has three operation modes including the mode not to use the internal flash memory.

**Table 18-1 Operation Modes**

Operation mode	Operation details
Single chip mode	After reset is cleared, it starts up from the internal flash memory.
Normal mode	In this operation mode, two different modes, i.e., the mode to execute user application programs and the mode to rewrite the flash memory onboard the user's card, are defined. The former is referred to as "normal mode" and the latter "user boot mode."
User boot mode	The user can uniquely configure the system to switch between these two modes. For example, the user can freely design the system such that the normal mode is selected when the port "A0" is set to "1" and the user boot mode is selected when it is set to "0." The user should prepare a routine as part of the application program to make the decision on the selection of the modes.
Single boot mode	After reset is cleared, it starts up from the internal Boot ROM (Mask ROM). In the Boot ROM, an algorithm to enable flash memory rewriting on the user's set through the serial port of this device is programmed. By connecting to an external host computer through the serial port, the internal flash memory can be programmed by transferring data in accordance with predefined protocols.

Among the flash memory operation modes listed in the above table, the User Boot mode and the Single Boot mode are the programmable modes. These two modes, the User Boot mode and the Single Boot mode, are referred to as "Onboard Programming" modes where onboard rewriting of internal flash memory can be made on the user's card.

Either the Single Chip or Single Boot operation mode can be selected by externally setting the level of the  $\overline{\text{BOOT}}$  (PH0) pin while the device is in reset status.

After the level is set, the CPU starts operation in the selected operation mode when the reset condition is removed. Regarding the  $\overline{\text{BOOT}}$  (PH0) pin, be sure not to change the levels during operation once the mode is selected.

The mode setting method and the mode transition diagram are shown below:

**Table 18-2 Operation Mode Setting**

Operation mode	Pin	
	$\overline{\text{RESET}}$	$\overline{\text{BOOT}}$ (PH0)
Single chip mode	0 → 1	1
Single boot mode	0 → 1	0

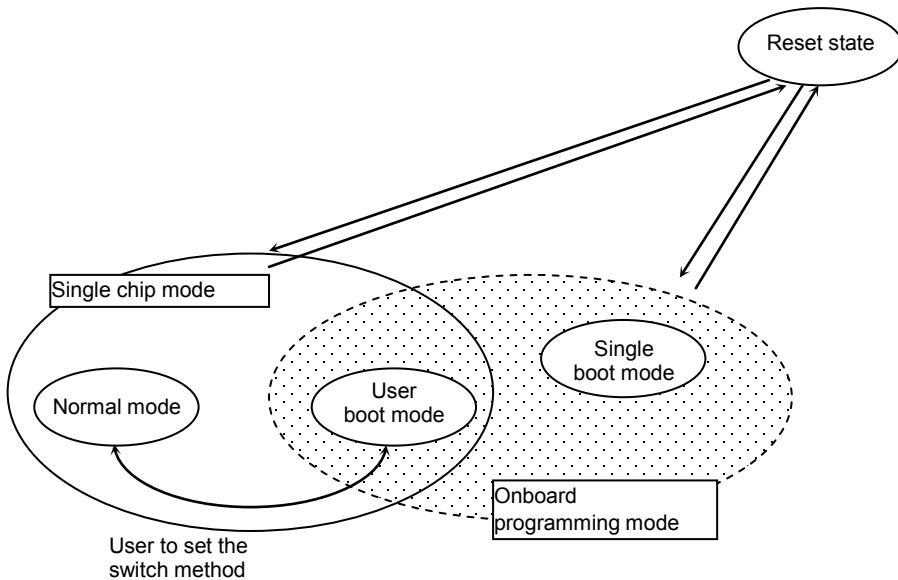

**Fig. 18-2 Mode Transition Diagram**

**18.2.1 Reset Operation**

To reset the device, ensure that the power supply voltage is within the operating voltage range, that the internal oscillator has been stabilized, and that the  $\overline{\text{RESET}}$  input is held at "0" for a minimum duration of 12 system clocks (0.3  $\mu\text{s}$  with 40MHz operation; the "1/1" clock gear mode is applied after reset).

**(Note 1) Regarding power-on reset of devices with internal flash memory;**  
 for devices with internal flash memory, it is necessary to apply "0" to the  $\overline{\text{RESET}}$  inputs upon power on for a minimum duration of 700 microseconds regardless of the operating frequency.

**(Note 2) While flash auto programming or deletion is in progress,** at least 0.5 microseconds of reset period is required regardless of the system clock frequency. In this condition, it takes approx. 2 ms to enable reading after reset.

### 18.2.2 User Boot Mode (Single chip mode)

User Boot mode is to use flash memory programming routine defined by users. It is used when the data transfer buses for flash memory program code on the old application and for serial I/O are different. It operates at the single chip mode; therefore, a switch from normal mode in which user application is activated at the single chip mode to User Boot Mode for programming flash is required. Specifically, add a mode judgment routine to a reset program in the old application.

The condition to switch the modes needs to be set by using the I/O of TMPM330 in conformity with the user's system setup condition. Also, flash memory programming routine that the user uniquely makes up needs to be set in the new application. This routine is used for programming after being switched to User Boot Mode. The execution of the programming routine must take place while it is stored in the area other than the flash memory since the data in the internal flash memory cannot be read out during delete/ writing mode. Once re-programming is complete, it is recommended to protect relevant flash blocks from accidental corruption during subsequent Single-Chip (Normal mode) operations. All the interruption including a non-maskable are inhibited at User Boot Mode.

(1-A) and (1-B) are the examples of programming with routines in the internal flash memory and in the external memory. For a detailed description of the erase and program sequence, refer to 0 On-board Programming of Flash Memory (Rewrite/Erase).

**User Boot Mode**

(1-A) Method 1: Storing a Programming Routine in the Flash Memory

**(Step-1)**

Determine the conditions (e.g., pin states) required for the flash memory to enter User Boot mode and the I/O bus to be used to transfer new program code. Create hardware and software accordingly. Before installing the TMPM330 on a printed circuit board, write the following program routines into an arbitrary flash block using programming equipment.

- (a) Mode judgment routine: Code to determine whether or not to switch to User Boot mode
- (b) Programming routine: Code to download new program code from a host controller and re-program the flash memory
- (c) Copy routine: Code to copy the data described in (b) from the TMPM330 flash memory to either the TMPM330 on-chip RAM or external memory device.

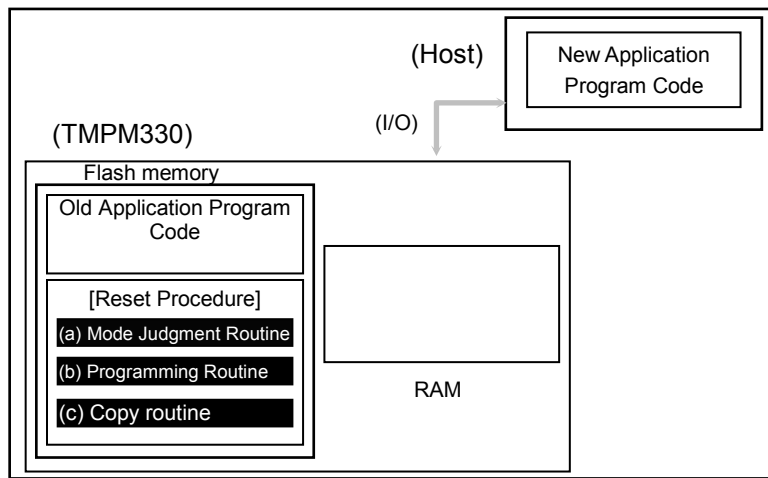

**(Step-2)**

After  $\overline{\text{RESET}}$  is released, the reset procedure determines whether to put the TMPM330 flash memory in User Boot mode. If mode switching conditions are met, the flash memory enters User Boot mode. (All interrupts including NMI must be disabled while in User Boot mode.)

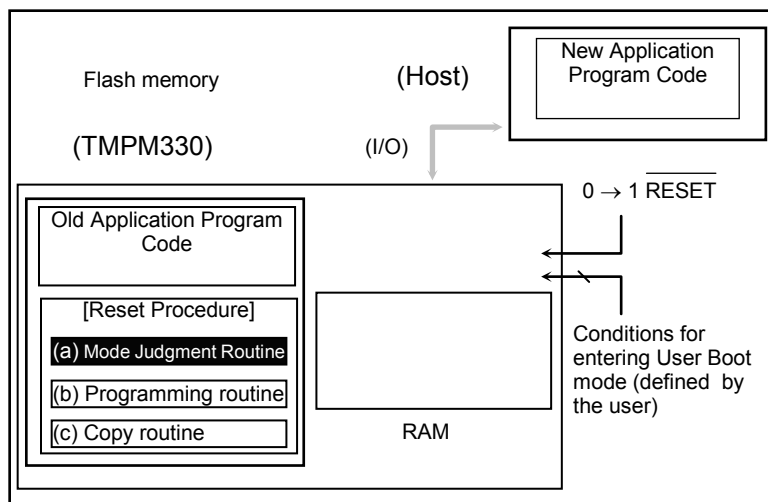

**(Step-3)**

Once transition to User Boot mode is occurred, execute the copy routine (c) to copy the flash programming routine (b) to the TMPM330 on-chip RAM.

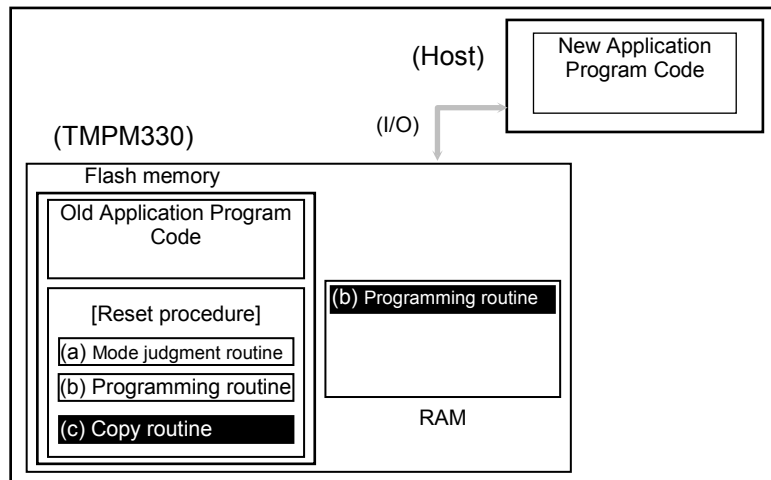

**(Step-4)**

Jump program execution to the flash programming routine in the on-chip RAM to erase a flash block containing the old application program code.

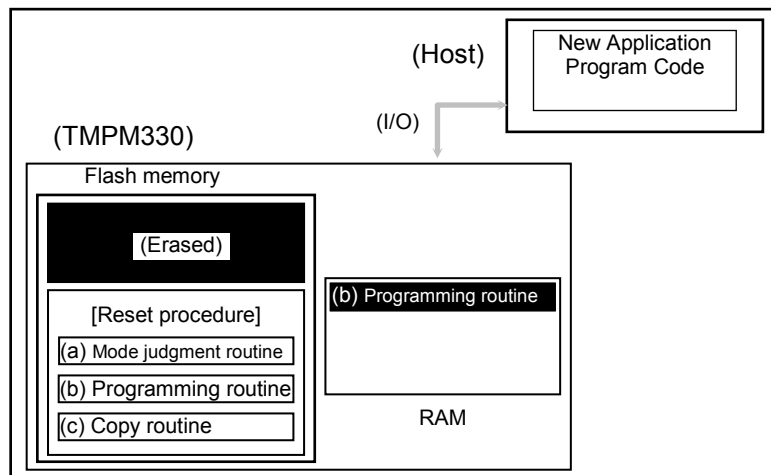

**(Step-5)**

Continue executing the flash programming routine to download new program code from the host controller and program it into the erased flash block. Once programming is complete, turn on the protection of that flash block.

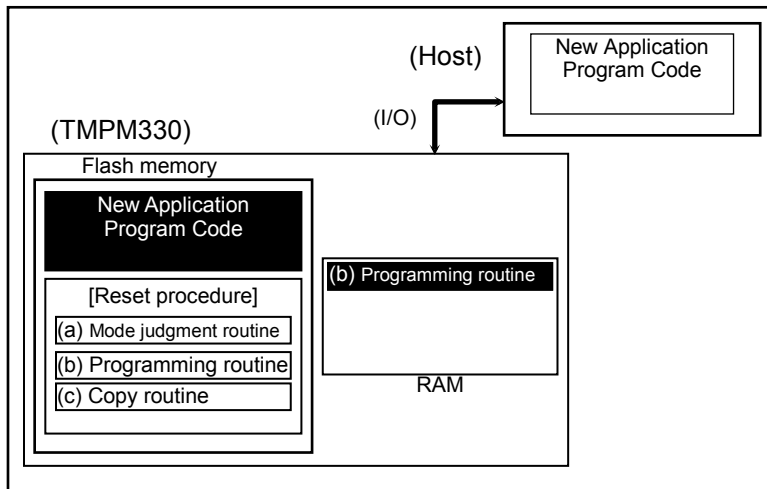

**(Step-6)**

Set  $\overline{\text{RESET}}$  to "0" to reset the TMPM330. Upon reset, the on-chip flash memory is put in Normal mode. After  $\overline{\text{RESET}}$  is released, the CPU will start executing the new application program code.

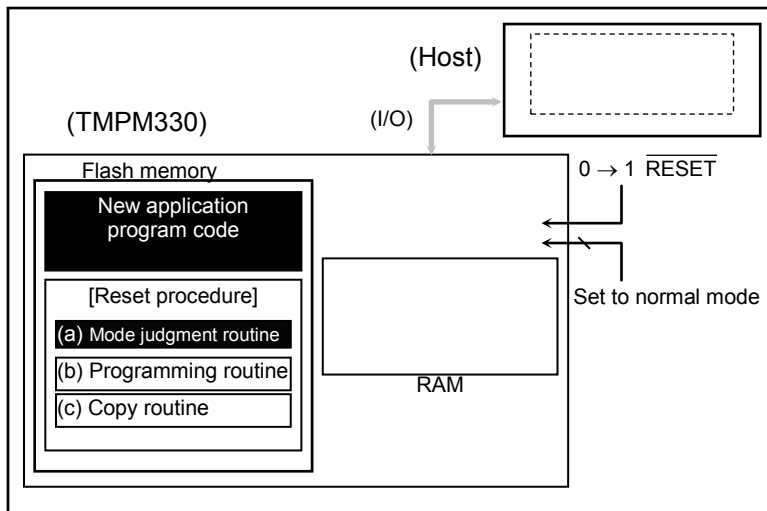

(1-B) Method 2: Transferring a Programming Routine from an External Host

**(Step-1)**

Determine the conditions (e.g., pin states) required for the flash memory to enter User Boot mode and the I/O bus to be used to transfer new program code. Create hardware and software accordingly. Before installing the TMPM330 on a printed circuit board, write the following program routines into an arbitrary flash block using programming equipment.

- (a) Mode judgment routine: Code to determine whether or not to switch to User Boot mode
- (b) Transfer routine: Code to download new program code from a host controller

Also, prepare a programming routine shown below on the host controller:

- (c) Programming routine: Code to download new program code from an external host controller and re-program the flash memory

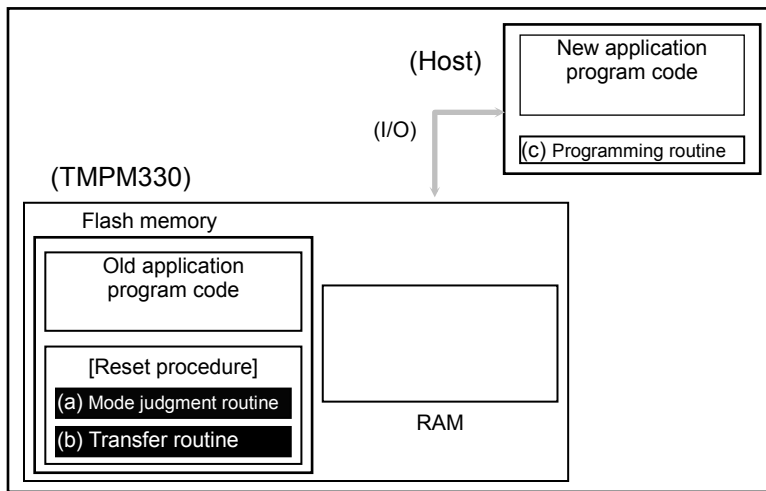

**(Step-2)**

After  $\overline{\text{RESET}}$  is released, the reset procedure determines whether to put the TMPM330 flash memory in User Boot mode. If mode switching conditions are met, the flash memory enters User Boot mode. (All interrupts including NMI must be disabled while in User Boot mode).

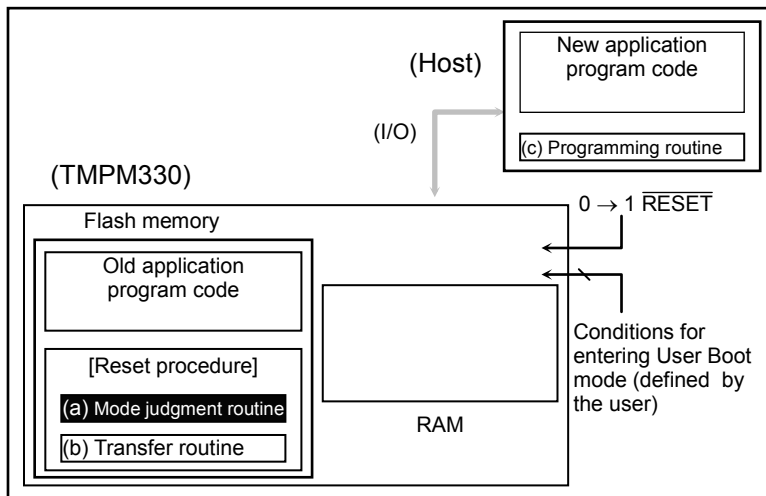

**(Step-3)**

Once User Boot mode is entered, execute the transfer routine (b) to download the flash programming routine (c) from the host controller to the TMPM330 on-chip RAM.

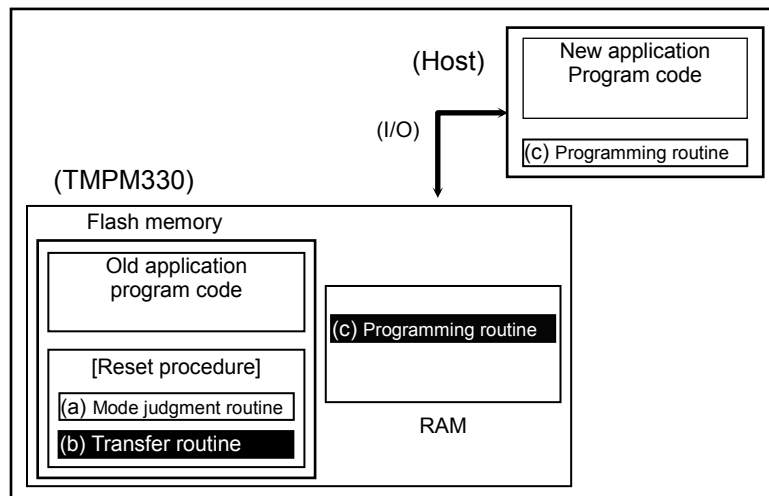

**(Step-4)**

Jump program execution to the flash programming routine in the on-chip RAM to erase a flash block containing the old application program code.

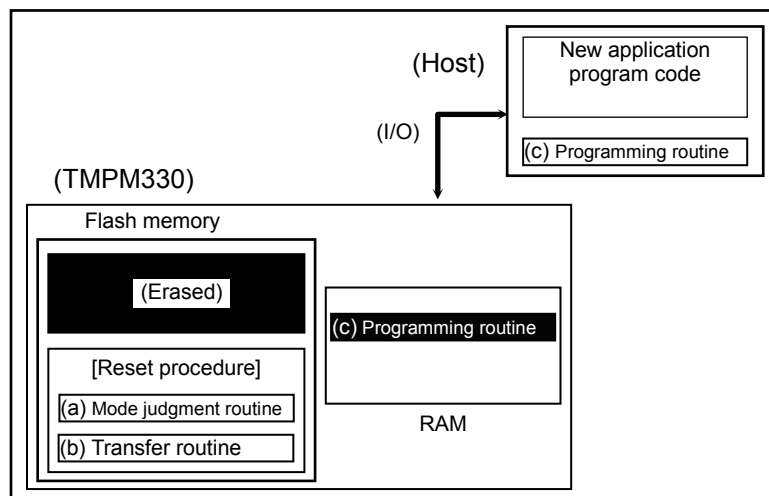

**(Step-5)**

Continue executing the flash programming routine to download new program code from the host controller and program it into the erased flash block. Once programming is complete, turn on the protection of that flash block.

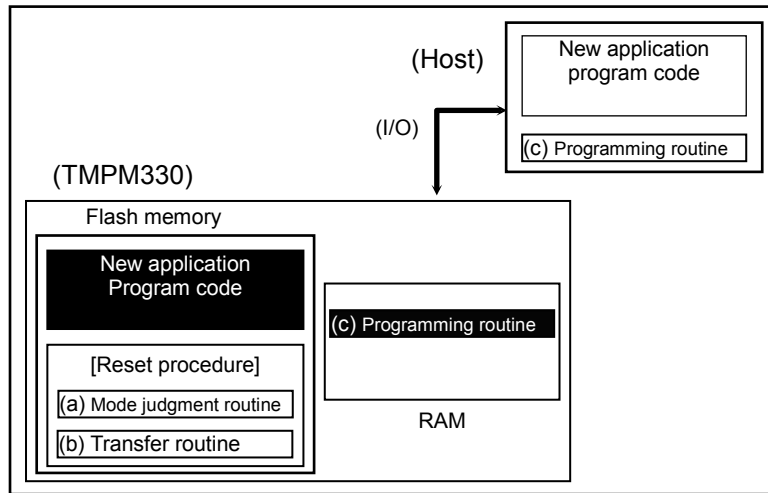

**(Step-6)**

Set  $\overline{\text{RESET}}$  to "0" low to reset the TMPM330. Upon reset, the on-chip flash memory is put in Normal mode. After  $\overline{\text{RESET}}$  is released, the CPU will start executing the new application program code.

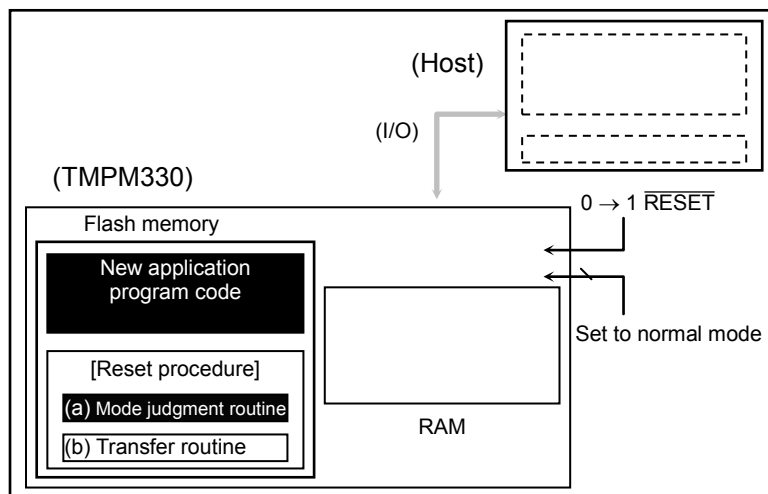

### 18.2.3 Single Boot Mode

In Single Boot mode, the flash memory can be re-programmed by using a program contained in the TMPM330 on-chip boot ROM. This boot ROM is a masked ROM. When Single Boot mode is selected upon reset, the boot ROM is mapped to the address region including the interrupt vector table while the flash memory is mapped to an address region different from it.

Single Boot mode allows for serial programming of the flash memory. Channel 0 of the SIO (SIO0) of the TMPM330 is connected to an external host controller. Via this serial link, a programming routine is downloaded from the host controller to the TMPM330 on-chip RAM. Then, the flash memory is re-programmed by executing the programming routine. The host sends out both commands and programming data to re-program the flash memory.

Communications between the SIO0 and the host must follow the protocol described later. To secure the contents of the flash memory, the validity of the application's password is verified before a programming routine is downloaded into the on-chip RAM. If password matching fails, the transfer of a programming routine itself is aborted.

As in the case of User Boot mode, all interrupts including the non-maskable interrupt (NMI) must be disabled in Single Boot mode while the flash memory is being erased or programmed. In Single Boot mode, the boot-ROM programs are executed in Normal mode.

Once re-programming is complete, it is recommended to protect relevant flash blocks from accidental corruption during subsequent Single-Chip (Normal mode) operations.

**Single Boot Mode**

(2-A) Using the Program in the On-Chip Boot ROM

**(Step-1)**

The flash block containing the older version of the program code need not be erased before executing the programming routine. Since a programming routine and programming data are transferred via the SIO (SIO2), the SIO2 must be connected to a host controller. Prepare a programming routine (a) on the host controller.

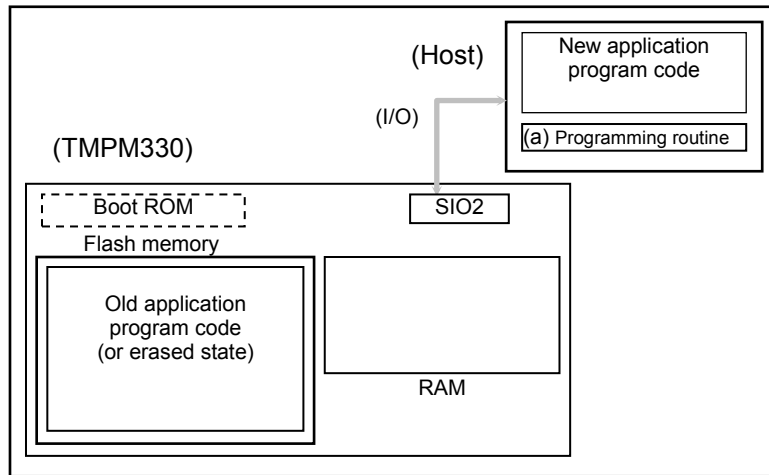

**(Step-2)**

Cancel the reset of the TMPM330 by setting the Single Boot mode pin to “0”, so that the CPU re-boots from the on-chip boot ROM. The 12-byte password transferred from the host controller via SIO2 is first compared to the contents of the special flash memory locations. (If the flash block has already been erased, the password is 0xFFFF).

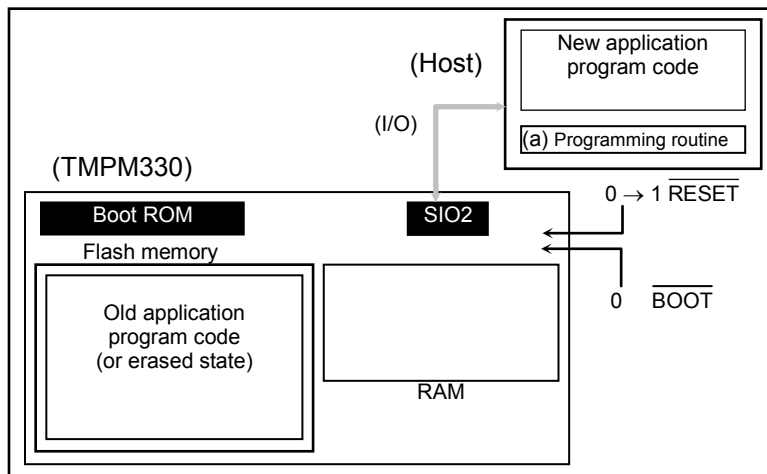

**(Step-3)**

If the password was correct, the boot program downloads, via the SIO0, the programming routine (a) from the host controller into the on-chip RAM of the TMPM330. The programming routine must be stored in the range from 0x2000\_0400 to the end address of RAM.

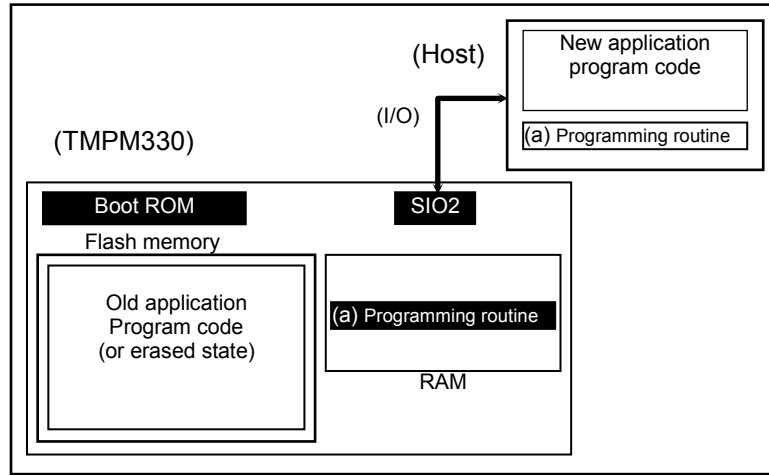

**(Step-4)**

The CPU jumps to the programming routine (a) in the on-chip RAM to erase the flash block containing the old application program code. The Block Erase or Chip Erase command may be used.

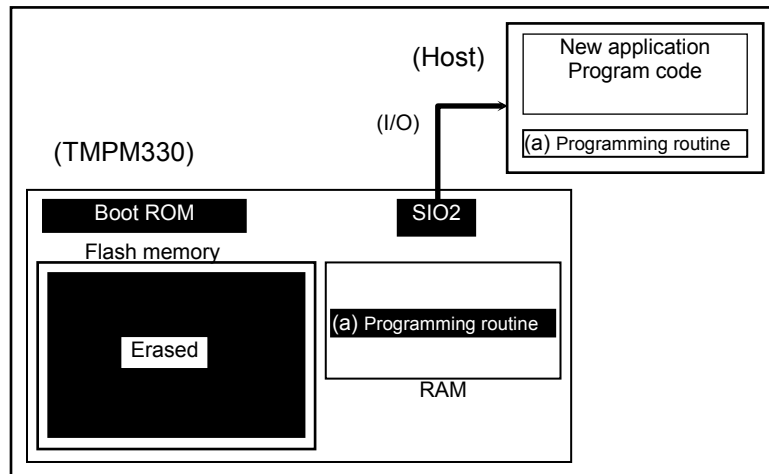

**(Step-5)**

Next, the programming routine (a) downloads new application program code from the host controller and programs it into the erased flash block. Once programming is complete, protection of that flash block is turned on. It is not allowed to move program control from the programming routine (a) back to the boot ROM.

In the example below, new program code comes from the same host controller via the same SIO0 channel as for the programming routine. However, once the programming routine has begun to execute, it is free to change the transfer path and the source of the transfer. Create board hardware and a programming routine to suit your particular needs.

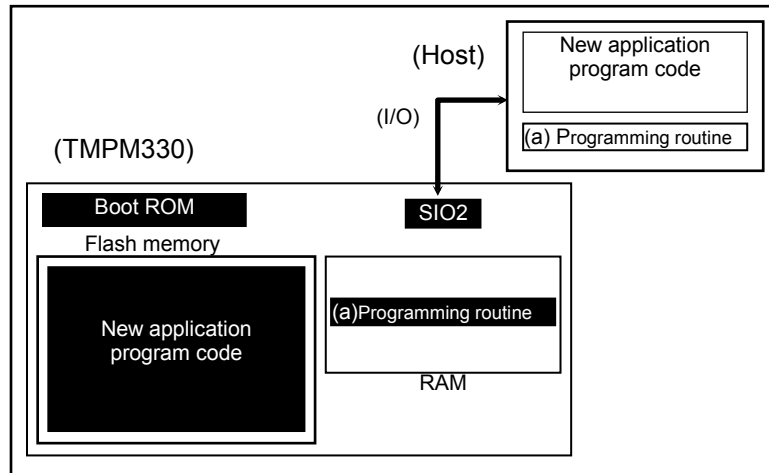

**(Step-6)**

When programming of the flash memory is complete, power off the board and disconnect the cable leading from the host to the target board. Turn on the power again so that the TMPM330 re-boots in Single-Chip (Normal) mode to execute the new program.

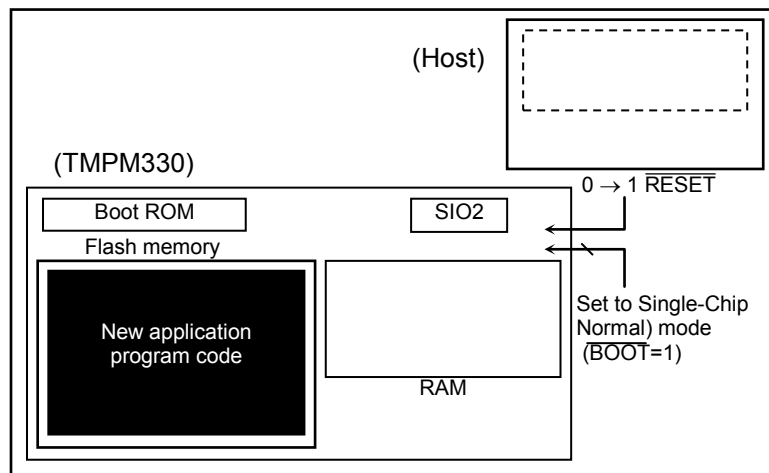

(1) Configuration for Single Boot Mode

To execute the on-board programming, boot the TMPM330 with Single Boot mode following the configuration shown below.

$$\overline{\text{BOOT}} \text{ (PH0)} = 0$$

$$\overline{\text{RESET}} = 0 \rightarrow 1$$

Set the  $\overline{\text{RESET}}$  input to 0, and set the each  $\overline{\text{BOOT}}$  (PH0) pins to values shown above, and then release RESET (high).

(2) Memory Map

Fig. 18-3 shows a comparison of the memory maps in Normal and Single Boot modes. In Single Boot mode, the internal flash memory is mapped to 0x3F80\_0000 and later addresses, and the Internal boot ROM (Mask ROM) is mapped to 0x0000\_0000 through 0x0000\_1FFF.

Product Name	Flash Size	RAM Size	Flash Address (Single Chip/ Single Boot Mode)	RAM Address
TMPM330FYWFG	256KB	16KB	0x0000_0000 - 0x0003_FFFF (0x0007_FE00 – 0x0007_FFFF)(Note) 0x3F80_0000 - 0x3F83_FFFF (0x3F87_FE00 – 0x3F87_FFFF)(Note)	0x2000_0000 - 0x2000_3FFF

**(Note) In addition to 256KB flash area, the TMPM330FYWFG provides 128-word data/password area (1 page) for Show Product Information command.**

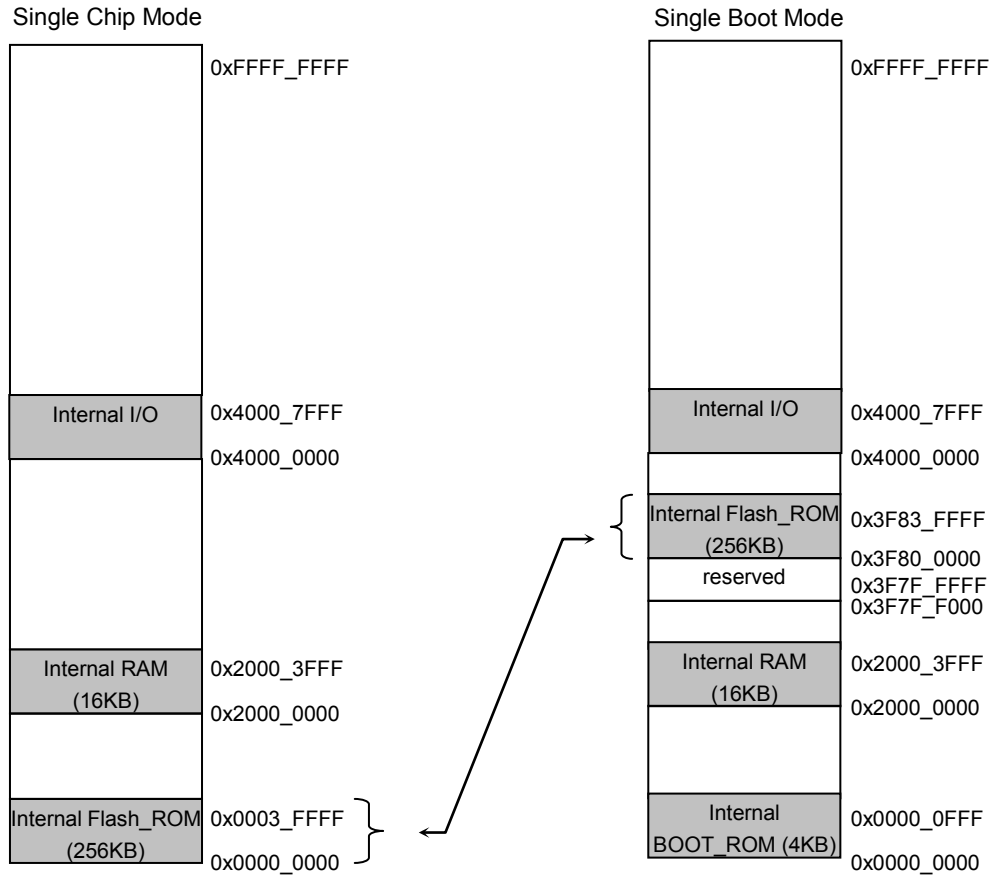

Fig. 18-3 Memory Maps

(3) Interface specification

In Single Boot mode, an SIO channel is used for communications with a programming controller. The same configuration is applied to a communication format on a programming controller to execute the on-board programming. Both UART (asynchronous) and I/O Interface (synchronous) modes are supported. The communication formats are shown below.

- UART communication

Communication channel : SIO channel 0  
 Serial transfer mode : UART (asynchronous), half -duplex, LSB fast  
 Data length : 8 bit  
 Parity bits : None  
 STOP bits : 1 bit  
 Baud rate : Arbitrary baud rate

- I/O interface mode

Communication channel : SIO channel 0  
 Serial transfer mode : I/O interface mode, full -duplex, LSB fast  
 Synchronization clock (SCLK0) : Input mode  
 Handshaking signal : PE4 configured as an output mode  
 Baud rate : Arbitrary baud rate

**Table 18-3 Required Pin Connections**

Pins		Interface	
		UART	I/O Interface Mode
Power supply pins	REGVCC	○	○
	AVCC	○	○
	DVCC	○	○
	CVCC	○	○
	REGVSS	○	○
	AVSS	○	○
	DVSS	○	○
	CVSS	○	○
Mode-setting pin	$\overline{\text{BOOT}}$ (PH0)	○	○
Reset pin	$\overline{\text{RESET}}$	○	○
Communication pins	TXD0(PE0)	○	○
	RXD0(PE1)	○	○
	SCLK0(PE2)	x	○ (Input mode)
	PE4	x	○ (Output mode)

## (4) Data Transfer Format

Table 18-4 and Table 18-6 to Table 18-9 illustrate the operation commands and data transfer formats at each operation mode. In conjunction with this section, refer to (6) Operation of Boot Program.

**Table 18-4 Single Boot Mode Commands**

Code	Command
10H	RAM transfer
20H	Show Flash Memory SUM
30H	Show Product Information
40H	Chip and protection bit erase

## (5) Restrictions on internal memories

Single Boot Mode places restrictions on the internal RAM and ROM as shown in Table 18-5.

**Table 18-5 Restrictions in Single Boot Mode**

Memory	Details
Internal RAM	BOOT ROM is mapped to 0x2000_0000 to 0x2000_03FF. Store the RAM transfer program from 0x2000_0400 through the end address of RAM.
Internal ROM	The following addresses are assigned for storing software ID information and passwords. Storing program in these addresses is not recommendable. TMPM330FYWFG : 0x3F87_FF00 - 0x3F87_FF0F

Table 18-6 Transfer Format for the RAM Transfer Command

	Byte	Data Transferred from the Controller to the TMPM330	Baud rate	Data Transferred from the TMPM330 to the Controller
Boot ROM	1 byte	Serial operation mode and baud rate For UART mode 86H For I/O Interface mode 30H	Desired baud rate (Note 1)	-
	2 byte	-		ACK for the serial operation mode byte For UART mode -Normal acknowledge 86H (The boot program aborts if the baud rate can not be set correctly.) For I/O Interface mode -Normal acknowledge 30H
	3 byte	Command code (10H)		-
	4 byte	-		ACK for the command code byte (Note 2) -Normal acknowledge 10H -Negative acknowledge x 1H -Communication error x 8H
	5 byte - 16 byte	Password sequence (12 bytes) 0x3F87_FF04~0x3F87_FF0F		-
	17 byte	Check SUM value for bytes 5 - 16		-
	18 byte	-		ACK for the checksum byte (Note 2) -Normal acknowledge 10H -Negative acknowledge x1H -Communication error x8H
	19 byte	RAM storage start address 31 - 24		-
	20 byte	RAM storage start address 23 - 16		-
	21 byte	RAM storage start address 15 - 8		-
	22 byte	RAM storage start address 7 - 0		-
	23 byte	RAM storage byte count 15 - 8		-
	24 byte	RAM storage byte count 7 - 0		-
	25 byte	Check SUM value for bytes 19 - 24		-
	26 byte	-		ACK for the checksum byte (Note 2) -Normal acknowledge 10H -Negative acknowledge x1H -Communication error x8H
	27 byte ~ m byte	RAM storage data		-
	m + byte	Checksum value for bytes 27 - m		-
m + byte	-	ACK for the checksum byte (Note 2) -Normal acknowledge 10H -Negative acknowledge x1H -Communication error x8H		
RAM	m + byte	-	Jump to RAM storage start address	

(Note 1) In I/O Interface mode, the baud rate for the transfers of the first and second bytes must be 1/16 of the desired baud rate.

(Note 2) In case of any negative acknowledge, the boot program returns to a state in which it waits for a command code (3rd byte). In I/O Interface mode, if a communication error occurs, a negative acknowledge does not occur.

(Note 3) The 19th to 25th bytes must be within the RAM address range from 0x2000\_0400 through the end address of RAM.

**Table 18-7 Transfer Format for the Show Flash Memory Sum Command**

	Byte	Data Transferred from the Controller to the TMPM330	Baud rate	Data Transferred from the TMPM330 to the Controller
Boot ROM	1 byte	Serial operation mode and baud rate For UART mode 86H For I/O Interface mode 30H	Desired baud rate (Note 1)	-
	2 byte	-		ACK for the serial operation mode byte For UART mode -Normal acknowledge 86H (The boot program aborts if the baud rate can not be set correctly.) For I/O Interface mode -Normal acknowledge 30H
	3 byte	Command code (20H)	-----	-
	4 byte	-		ACK for the command code byte (Note 2) -Normal acknowledge 20H -Negative acknowledge x1H -Communication error x8H
	5 byte	-		SUM (upper byte)
	6 byte	-		SUM (lower byte)
	7 byte	-		Checksum value for bytes 5 and 6
	8 byte	(Wait for the next command code.)		-

**(Note 1)** In I/O Interface mode, the baud rate for the transfers of the first and second bytes must be 1/16 of the desired baud rate.

**(Note 2)** In case of any negative acknowledge, the boot program returns to a state in which it waits for a command code (3rd byte). In I/O Interface mode, if a communication error occurs, a negative acknowledge does not occur.

Table 18-8 Transfer Format for the Show Product Information Command (1/2)

	Byte	Data Transferred from the Controller to the TMPM330	Baud rate	Data Transferred from the TMPM330 to the Controller
Boot ROM	1 byte	Serial operation mode and baud rate For UART mode 86H For I/O Interface mode 30H	Desired baud rate (Note 1)	-
	2 byte	-		ACK for the serial operation mode byte For UART mode -Normal acknowledge 86H (The boot program aborts if the baud rate can not be set correctly.) For I/O Interface mode -Normal acknowledge 30H
	3 byte	Command code (30H)		-
	4 byte	-		ACK for the command code byte (Note 2) -Normal acknowledge 30H -Negative acknowledge × 1H -Communication error × 8H
	5 byte	-		Flash memory data at address 0x3F87_FF00
	6 byte	-		Flash memory data at address 0x3F87_FF01
	7 byte	-		Flash memory data at address 0x3F87_FF02
	8 byte	-		Flash memory data at address 0x3F87_FF03
	9 byte - 20 byte	-		Product name (12-byte ASCII code) From the 9th byte: 'TMPM330FD_ _'
	21 byte - 24 byte	-		Password comparison start address (4 bytes) From the 21 <sup>st</sup> byte: 04H, FFH, 87H, 3FH
	25 byte - 28 byte	-		RAM start address (4 bytes) 00H, 00H, 00H and 20H from the 25 <sup>th</sup> byte
	29 byte - 32 byte	-		Dummy data (4 bytes) 00H, 00H, 00H and 00H from the 29 <sup>th</sup> byte
	33 byte - 36 byte	-		RAM end address (4 bytes) From the 33 <sup>rd</sup> byte: FFH, 7FH, 00H, 20H
	37 byte - 40 byte	-		Dummy data (4 bytes) 00H, 00H, 00H and 00H from the 37 <sup>th</sup> byte.
	41 byte - 44 byte	-		Dummy data (4 bytes) 00H, 00H, 00H and 00H from the 41 <sup>st</sup> byte
	45 byte - 46 byte	-		Fuse information (2 bytes) 00H and 00H from the 45 <sup>th</sup> byte.
	47 byte - 50 byte	-		Flash memory start address (4 bytes) 00H, 00H, 80H and 3FH from the 47 <sup>th</sup> byte
	51 byte - 54 byte	-		Flash memory end address (4 bytes) From the 51 <sup>st</sup> byte: FFH, FFH, 87H, 3FH
	55 byte - 56 byte	-		Flash memory block count (2 bytes) From the 55 <sup>th</sup> byte: 06H, 00H

**Table 18-8 Transfer Format for the Show Product Information Command (2/2)**

	Byte	Data Transferred from the Controller to the TMPM330	Baud rate	Data Transferred from the TMPM330 to the Controller
Boot ROM	57 byte - 60 byte	-		Start address of a group of the same-size (16K) flash blocks (4 bytes) From 57 <sup>th</sup> byte: 00H, 00H, 00H, 00H
	61 byte - 64 byte	-		Size (in halfwords) of the same-size (16K) flash blocks (4 bytes) 00H, 20H, 00H and 00H from the 61 <sup>st</sup> byte
	65 byte	-		Number of flash blocks of the same size (1 byte) 00H
	66 byte - 69 byte	-		Start address of a group of the same-size (32K) flash blocks (4 bytes) From 66 <sup>th</sup> byte: 00H, 00H, 80H, 3FH
	70 byte - 73 byte			Size (in halfwords) of the same-size (32K) flash blocks (4 bytes) 00H, 40H, 00H and 00H from the 70 <sup>th</sup> byte
	74 byte			Number of flash blocks of the same size (32K) (1 byte) 02H
	75 byte - 78 byte			Start address of a group of the same-size (64K) flash blocks (4 bytes) 00H, 00H, 81H and 3FH from 75 <sup>th</sup> byte
	79 byte - 82 byte			Size (in halfwords) of the same-size (64K) flash blocks (4 bytes) 00H, 80H, 00H and 00H from the 79 <sup>th</sup> byte
	83 byte			Number of flash blocks of the same size (64K) (1 byte) From 83 <sup>rd</sup> byte: 01H
	84 byte - 87 byte			Start address of a group of the same-size (128K) flash blocks (4 bytes) From 84 <sup>th</sup> byte: 00H, 00H, 82H, 3FH
	88 byte - 91 byte			Size (in halfwords) of the same-size (128K) flash blocks (4 bytes) 00H, 00H, 01H and 00H from the 88 <sup>th</sup> byte
	92 byte			Number of flash blocks of the same size (128K) (1 byte) 03H
	93 byte			Checksum value for bytes 5 - 92
	94 byte	(Wait for the next command code.)		-

**(Note 1)** In I/O Interface mode, the baud rate for the transfers of the first and second bytes must be 1/16 of the desired baud rate.

**(Note 2)** In case of any negative acknowledge, the boot program returns to a state in which it waits for a command code (3rd byte). In I/O Interface mode, if a communication error occurs, a negative acknowledge does not occur.

**(Note 3)** The flash memory actual end address of the TMPM330FYWFG is 0x3F83\_FFFF. In addition to 256KB flash area, the TMPM330FYWFG provides 128-word data/ password area (0x3F87\_FF00 to 0x3F87\_FF80, 1 page) for Show Product Information command.

Table 18-9 Transfer Format for the Chip and Protection Bit Erase Command

	Byte	Data Transferred from the Controller to the TMPM330	Baud rate	Data Transferred from the TMPM330 to the Controller
Boot ROM	1 byte	Serial operation mode and baud rate For UART mode 86H For I/O Interface mode 30H	Desired baud rate (Note 1)	—
	2 byte	—		ACK for the serial operation mode byte For UART mode -Normal acknowledge 86H For I/O Interface mode -Normal acknowledge 30H (The boot program aborts if the baud rate can not be set correctly.)
	3 byte	Command code (40H)		—
	4 byte	—		ACK for the command code byte (Note 2) -Normal acknowledge 40H -Negative acknowledge × 1H -Communication error × 8H
	5 byte	Chip erase command code (54H)		—
	6 byte	—		ACK for the command code byte (Note 2) -Normal acknowledge 54H -Negative acknowledge × 1H -Communication error × 8H
	7 byte	—		ACK for the chip erase command code byte -Normal acknowledge 4FH -Negative acknowledge 4CH
	8 byte	(Wait for the next command code.)		—

**(Note 1)** In I/O Interface mode, the baud rate for the transfers of the first and second bytes must be 1/16 of the desired baud rate.

**(Note 2)** In case of any negative acknowledge, the boot program returns to a state in which it waits for a command code (3rd byte). In I/O Interface mode, if a communication error occurs, a negative acknowledge does not occur.

(6) Operation of Boot Program

When Single Boot mode is selected, the boot program is automatically executed on startup. The boot program offers these three commands, of which the details are provided on the following subsections. The addresses described in this section are the virtual unless otherwise noted.

1. RAM Transfer command

The RAM Transfer command stores program code transferred from a host controller to the on-chip RAM and executes the program once the transfer is successfully completed. The user program RAM space can be assigned to the range from 0x2000\_0400 to the end address of RAM, whereas the boot program area (0x2000\_0000 ~ 0x2000\_03FF) is unavailable. The user program starts at the assigned RAM address.

The RAM Transfer command can be used to download a flash programming routine of your own; this provides the ability to control on-board programming of the flash memory in a unique manner. The programming routine must utilize the flash memory command sequences described in Section 0.

Before initiating a transfer, the RAM Transfer command verifies a password sequence coming from the controller against that stored in the flash memory.

Note: If a password is set to 0xFF (erased data), it is difficult to protect data securely due to an easy-to-guess password.

Even if Single Boot mode is not used, it is recommended to set a unique value as a password.

2. Show Flash Memory Sum command

The Show Flash Memory Sum command adds the entire contents of the flash memory together. The boot program does not provide a command to read out the contents of the flash memory. Instead, the Flash Memory Sum command can be used for software revision management.

3. Show Product Information command

The Show Product Information command provides the product name, on-chip memory configuration and the like. This command also reads out the contents of the flash memory locations at addresses shown below. In addition to the Show Flash Memory Sum command, these locations can be used for software revision management.

Product name	Area
TMPM330FYWFG	0x3F87_FF00 – 0x3F87_FF03

4. Chip and Protection Bit Erase command

This command erases the entire area of the flash memory automatically without verifying a password. All the blocks in the memory cell and their protection conditions are erased even when any of the blocks are prohibited from writing and erasing. When the command is completed, the SECBIT <SECBIT> bit is set to “1”.

This command serves to recover boot programming operation when a user forgets the password. Therefore password verification is not executed.

- 1) RAM Transfer Command (See Table 18-6)
  1. The 1st byte specifies which one of the two serial operation modes is used. For a detailed description of how the serial operation mode is determined, see Determination of a Serial Operation Mode described later. If it is determined as UART mode, the boot program then checks if the SIO0 is programmable to the baud rate at which the 1st byte was transferred. During the first-byte interval, the RXE bit in the HSC0MOD register is cleared
    - To communicate in UART mode  
Send, from the controller to the target board, 86H in UART data format at the desired baud rate. If the serial operation mode is determined as UART, then the boot program checks if the SIO0 can be programmed to the baud rate at which the first byte was transferred. If that baud rate is not possible, the boot program aborts, disabling any subsequent communications.
    - To communicate in I/O Interface mode  
Send, from the controller to the target board, 30H in I/O Interface data format at 1/16 of the desired baud rate. Also send the 2nd byte at the same baud rate. Then send all subsequent bytes at a rate equal to the desired baud rate.

In I/O Interface mode, the CPU sees the serial receive pin as if it were a general input port in monitoring its logic transitions. If the baud rate of the incoming data is high or the chip's operating frequency is high, the CPU may not be able to keep up with the speed of logic transitions. To prevent such situations, the 1st and 2nd bytes must be transferred at 1/16 of the desired baud rate; then the boot program calculates 16 times that as the desired baud rate. When the serial operation mode is determined as I/O Interface mode, the SIO0 is configured for SCLK Input mode. Beginning with the third byte, the controller must ensure that its AC timing restrictions are satisfied at the selected baud rate. In the case of I/O Interface mode, the boot program does not check the receive error flag; thus there is no such thing as error acknowledge (bit 3, x8H).

2. The 2nd byte, transmitted from the target board to the controller, is an acknowledge response to the 1st byte. The boot program echoes back the first byte: 86H for UART mode and 30H for I/O Interface mode.
  - UART mode  
If the SIO0 can be programmed to the baud rate at which the 1st byte was transferred, the boot program programs the SC0BRCCR and sends back 86H to the controller as an acknowledge. If the SIO0 is not programmable at that baud rate, the boot program simply aborts with no error indication. Following the 1st byte, the controller should allow for a time-out period of five seconds. If it does not receive 86H within the allowed time-out period, the controller should give up the communication. The boot program sets the RXE bit in the SC0MOD0 register to enable reception (1) before loading the SIO transmit buffer with 86H.
  - I/O Interface mode  
The boot program programs the SC0MOD0 and SC0CR registers to configure the SIO0 in I/O Interface mode (clocked by the rising edge of SCLK0), writes 30H to the

SC0BUF. Then, the SIO0 waits for the SCLK0 signal to come from the controller. Following the transmission of the 1st byte, the controller should send the SCLK clock to the target board after a certain idle time (several microseconds). This must be done at 1/16 the desired baud rate. If the 2nd byte, which is from the target board to the controller, is 30H, then the controller should take it as a go-ahead. The controller must then deliver the 3rd byte to the target board at a rate equal to the desired baud rate. The boot program sets the RXE bit in the SC0MOD register to enable reception before loading the SIO transmit buffer with 30H.

3. The 3rd byte transmitted from the controller to the target board is a command. The code for the RAM Transfer command is 10H.
4. The 4th byte, transmitted from the target board to the controller, is an acknowledge response to the 3rd byte. Before sending back the acknowledge response, the boot program checks for a receive error. If there was a receive error, the boot program transmits x8H (bit 3) and returns to the state in which it waits for a command (the third byte) again. In this case, the upper four bits of the acknowledge response are undefined - they hold the same values as the upper four bits of the previously issued command. When the SIO0 is configured for I/O Interface mode, the boot program does not check for a receive error.

If the 3rd byte is equal to any of the command codes listed in Table 18-4, the boot program echoes it back to the controller. When the RAM Transfer command was received, the boot program echoes back a value of 10H and then branches to the RAM Transfer routine. Once this branch is taken, password verification is done. Password verification is detailed in a later section "Password". If the 3rd byte is not a valid command, the boot program sends back x1H (bit 0) to the controller and returns to the state in which it waits for a command (the third byte) again. In this case, the upper four bits of the acknowledge response are undefined - they hold the same values as the upper four bits of the previously issued command.

5. The 5th to 16th bytes transmitted from the controller to the target board, are a 12-byte password. Each byte is compared to the contents of following addresses in the flash memory. The verification is started with the 5<sup>th</sup> byte and the smallest address in the designated area. If the password verification fails, the RAM Transfer routine sets the password error flag.

Product name	Area
TMPM330FYWFG	0x3F87_FF04 – 0x3F87_FF0F

6. The 17th byte is a checksum value for the password sequence (5th to 16th bytes). To calculate the checksum value for the 12-byte password, add the 12 bytes together, drop the carries and take the two's complement of the total sum. Transmit this checksum value from the controller to the target board. The checksum calculation is described in details in a later section "Checksum Calculation".
7. The 18th byte, transmitted from the target board to the controller, is an acknowledge response to the 5th to 17th bytes. First, the RAM Transfer routine checks for a receive

error in the 5th to 17th bytes. If there was a receive error, the boot program sends back 18H (bit 3) and returns to the state in which it waits for a command (i.e., the 3rd byte) again. In this case, the upper four bits of the acknowledge response are the same as those of the previously issued command (i.e., all 1s). When the SIO0 is configured for I/O Interface mode, the RAM Transfer routine does not check for a receive error.

Next, the RAM Transfer routine performs the checksum operation to ensure data integrity. Adding the series of the 5th to 16th bytes must result in 00H (with the carry dropped). If it is not 00H, one or more bytes of data has been corrupted. In case of a checksum error, the RAM Transfer routine sends back 11H to the controller and returns to the state in which it waits for a command (i.e., the 3rd byte) again.

Finally, the RAM Transfer routine examines the result of the password verification. The following two cases are treated as a password error. In these cases, the RAM Transfer routine sends back 11H (bit 0) to the controller and returns to the state in which it waits for a command (i.e., the 3rd byte) again.

- Irrespective of the result of the password comparison, all the 12 bytes of a password in the flash memory are the same value other than FFH. Not the entire password bytes transmitted from the controller matched those contained in the flash memory.

When all the above verification has been successful, the RAM Transfer routine returns a normal acknowledge response (10H) to the controller.

8. The 19th to 22nd bytes, transmitted from the controller the target board, indicate the start address of the RAM region where subsequent data (e.g., a flash programming routine) should be stored. The 19th byte corresponds to bits 31–24 of the address and the 22nd byte corresponds to bits 7–0 of the address. The start address of the stored RAM must be even address.
9. The 23rd and 24th bytes, transmitted from the controller to the target board, indicate the number of bytes that will be transferred from the controller to be stored in the RAM. The 23rd byte corresponds to bits 15–8 of the number of bytes to be transferred, and the 24th byte corresponds to bits 7–0 of the number of bytes.
10. The 25th byte is a checksum value for the 19th to 24th bytes. To calculate the checksum value, add all these bytes together, drop the carries and take the two's complement of the total sum. Transmit this checksum value from the controller to the target board. The checksum calculation is described in details in a later section "Checksum Calculation".
11. The 26th byte, transmitted from the target board to the controller, is an acknowledge response to the 19th to 25th bytes of data. First, the RAM Transfer routine checks for a receive error in the 19th to 25th bytes. If there was a receive error, the RAM Transfer routine sends back 18H and returns to the command wait state (i.e., the 3rd byte) again. In this case, the upper four bits of the acknowledge response are the same as those of the previously issued command (i.e., all 1s). When the SIO0 is configured for I/O Interface mode, the RAM Transfer routine does not check for a receive error.

Next, the RAM Transfer routine performs the checksum operation to ensure data integrity. Adding the series of the 19th to 25th bytes must result in 00H (with the carry dropped). If it is not 00H, one or more bytes of data has been corrupted. In case of a checksum error, the RAM Transfer routine sends back 11H to the controller and returns to the state in which it waits for a command (i.e., the 3rd byte) again.

- The RAM storage start address must be within the range of 0x2000\_0400 to the end address of RAM.

When the above checks have been successful, the RAM Transfer routine returns a normal acknowledge response (10H) to the controller.

12. The 27th to mth bytes from the controller are stored in the on-chip RAM of the TMPM330. Storage begins at the address specified by the 19th–22nd bytes and continues for the number of bytes specified by the 23rd–24th bytes.
13. The (m+1) th byte is a checksum value. To calculate the checksum value, add the 27th to mth bytes together, drop the carries and take the two's complement of the total sum. Transmit this checksum value from the controller to the target board. The checksum calculation is described in details in a later section "Checksum Calculation".
14. The (m+2) th byte is a acknowledge response to the 27th to (m+1) th bytes.  
First, the RAM Transfer routine checks for a receive error in the 27th to (m+1) th bytes. If there was a receive error, the RAM Transfer routine sends back 18H (bit 3) and returns to the state in which it waits for a command (i.e., the 3rd byte) again. In this case, the upper four bits of the acknowledge response are the same as those of the previously issued command (i.e., all 1s). When the SIO0 is configured for I/O Interface mode, the RAM Transfer routine does not check for a receive error.

Next, the RAM Transfer routine performs the checksum operation to ensure data integrity. Adding the series of the 27th to (m+1) th bytes must result in 00H (with the carry dropped). If it is not 00H, one or more bytes of data has been corrupted. In case of a checksum error, the RAM Transfer routine sends back 11H (bit 0) to the controller and returns to the command wait state (i.e., the 3rd byte) again. When the above checks have been successful, the RAM Transfer routine returns a normal acknowledge response (10H) to the controller.

15. If the (m+2) th byte was a normal acknowledge response, a branch is made to the address specified by the 19th to 22nd bytes.

## 2) Show Flash Memory Sum Command (See Table 18-7)

1. The processing of the 1st and 2nd bytes are the same as for the RAM Transfer command.
2. The 3rd byte, which the target board receives from the controller, is a command. The code for the Show Flash Memory Sum command is 20H.
3. The 4th byte, transmitted from the target board to the controller, is an acknowledge response to the 3rd byte. Before sending back the acknowledge response, the boot program checks for a receive error. If there was a receive error, the boot program transmits x8H (bit 3) and returns to the command wait state again. In this case, the upper four bits of the acknowledge response are undefined - they hold the same values as the upper four bits of the previously issued command. When the SIO0 is configured for I/O Interface mode, the boot program does not check for a receive error.

If the 3rd byte is equal to any of the command codes listed in Table 18-4, the boot program echoes it back to the controller. When the Show Flash Memory Sum command was received, the boot program echoes back a value of 20H and then branches to the Show Flash Memory Sum routine. If the 3rd byte is not a valid command, the boot program sends back x1H (bit 0) to the controller and returns to the command wait state (the third byte) again. In this case, the upper four bits of the acknowledge response are undefined - they hold the same values as the upper four bits of the previously issued command.

4. The Show Flash Memory Sum routine adds all the bytes of the flash memory together. The 5th and 6th bytes, transmitted from the target board to the controller, indicate the upper and lower bytes of this total sum, respectively. For details on sum calculation, see a later section "Calculation of the Show Flash Memory Sum Command".
5. The 7th byte is a checksum value for the 5th and 6th bytes. To calculate the checksum value, add the 5th and 6th bytes together, drop the carry and take the two's complement of the sum. Transmit this checksum value from the controller to the target board.
6. The 8th byte is the next command code.

3) Show Product Information Command (See Table 18-8)

1. The processing of the 1st and 2nd bytes are the same as for the RAM Transfer command.
2. The 3rd byte, which the target board receives from the controller, is a command. The code for the Show Product Information command is 30H.
3. The 4th byte, transmitted from the target board to the controller, is an acknowledge response to the 3rd byte. Before sending back the acknowledge response, the boot program checks for a receive error. If there was a receive error, the boot program transmits x8H (bit 3) and returns to the command wait state again. In this case, the upper four bits of the acknowledge response are undefined - they hold the same values as the upper four bits of the previously issued command. When the SIO0 is configured for I/O Interface mode, the boot program does not check for a receive error.

If the 3rd byte is equal to any of the command codes listed in Table 18-4, the boot program echoes it back to the controller. When the Show Flash Memory Sum command was received, the boot program echoes back a value of 30H and then branches to the Show Flash Memory Sum routine. If the 3rd byte is not a valid command, the boot program sends back x1H (bit 0) to the controller and returns to the state in which it waits for a command (the third byte) again. In this case, the upper four bits of the acknowledge response are undefined - they hold the same values as the upper four bits of the previously issued command.

4. The 5th to 8th bytes, transmitted from the target board to the controller, are the data read from addresses shown below in the flash memory. Software version management is possible by storing a software ID in these locations.

Product name	Area
TMPM330FYWFG	0x3F87_FF00 – 0x3F87_FF03

5. The 9th to 20th bytes, transmitted from the target board to the controller, indicate the product name as shown below (where [ ] is a space) in ASCII code.

Product name	Code
TMPM330FYWFG	T, M, P, M, 3, 3, 0, F, D, _, [ ], _

6. The 21st to 24th bytes, transmitted from the target board to the controller, indicate the start address of the flash memory area containing the password.

Product name	Address
TMPM330FYWFG	04H, FFH, 87H, 3FH

7. The 25th to 28th bytes, transmitted from the target board to the controller, indicate the start address of the on-chip RAM, i.e., 00H, 00H, FDH, FFH.
8. The 29th to 32nd bytes, transmitted from the target board to the controller, are dummy data (00H, 00H, 00H and 00H).
9. The 33rd to 36th bytes, transmitted from the target board to the controller, indicate the end address of the on-chip RAM.

Product name	Address
TMPM330FYWFG	FFH, 7FH, 00H, 20H

**(Note) The RAM actual end address of the TMPM330FYWFG is 0x2000\_3FFF.**

10. The 37th to 40th bytes, transmitted from the target board to the controller, are 00H, 00H, 00H and 00H. The 41st to 44th bytes, transmitted from the target board to the controller, are FFH, EFH, FDH and FFH.

11. The 45th and 46th bytes transmitted are 01H, 00H.
12. The 47th to 50th bytes, transmitted from the target board to the controller, indicate the start address of the on-chip flash memory, are 00H, 00H, 80H, and 3FH.
13. The 51st to 54th bytes, transmitted from the target board to the controller, indicate the end address of the on-chip flash memory.

Product name	Address
TMPM330FYWFG	FFH, FFH, 87H, 3FH

**(Note)** The flash memory actual end address of the TMPM330FYWFG is 0x3F83\_FFFF. In addition to 256KB flash area, the TMPM330FYWFG provides 128-word data area (0x3F87\_FF00 . 0x3F87\_FF80, 1 page) for Show Product Information command and the password area.

14. The 55th to 56th bytes, transmitted from the target board to the controller, indicate the number of flash blocks available.

Product name	Number of flash blocks
TMPM330FYWFG	06H, 00H

15. The 57th to 83rd bytes, transmitted from the target board to the controller, contain information about the flash blocks. Flash blocks of the same size are treated as a group. Information about the flash blocks indicate the start address of a group, the size of the blocks in that group (in halfwords) and the number of the blocks in that group.

The 57th to 65th bytes are the information about the 16-kbyte blocks. The 66th to 74th bytes are the information about the 32-kbyte blocks. The 75th to 83rd bytes are the information about the 64-kbyte blocks. The 84th to 92nd bytes are the information about the 128-kbyte blocks. See Table 18-8 for the values of bytes transmitted.

16. The 66th byte, transmitted from the target board to the controller, is a checksum value for the 5th to 92nd bytes. The checksum value is calculated by adding all these bytes together, dropping the carry and taking the two's complement of the total sum.
17. The 94th byte is the next command code.

- 4) Chip and Protection Bit Erase command (See Table 18-9)
  1. The processing of the 1st and 2nd bytes are the same as for the RAM Transfer command.
  2. The 3rd byte, which the target board receives from the controller, is a command. The code for the Show Product Information command is 40H.
  3. The 4th byte, transmitted from the target board to the controller, is an acknowledge response to the 3rd byte. Before sending back the acknowledge response, the boot program checks for a receive error. If there was a receive error, the boot program transmits x8H (bit 3) and returns to the command wait state again. In this case, the upper four bits of the acknowledge response are undefined - they hold the same values as the upper four bits of the previously issued command.

If the 3rd byte is equal to any of the command codes listed in Table 18-4, the boot program echoes it back to the controller. When the Show Flash Memory Sum command was received, the boot program echoes back a value of 40H. If the 3rd byte is not a valid command, the boot program sends back x1H (bit 0) to the controller and returns to the state in which it waits for a command (the third byte) again. In this case, the upper four bits of the acknowledge response are undefined - they hold the same values as the upper four bits of the previously issued command.
  4. The 5th byte, transmitted from the target board to the controller, is the Chip Erase Enable command code (54H).
  5. The 6th byte, transmitted from the target board to the controller, is an acknowledge response to the 5th byte.

Before sending back the acknowledge response, the boot program checks for a receive error. If there was a receive error, the boot program transmits x8H (bit 3) and returns to the command wait state again. In this case, the upper four bits of the acknowledge response are undefined - they hold the same values as the upper four bits of the previously issued command.

If the 5th byte is equal to any of the command codes to enable erasing, the boot program echoes it back to the controller. When the Show Flash Memory Sum command was received, the boot program echoes back a value of 54H and then branches to the Chip Erase routine. If the 5th byte is not a valid command, the boot program sends back x1H (bit 0) to the controller and returns to the state in which it waits for a command (the third byte) again. In this case, the upper four bits of the acknowledge response are undefined - they hold the same values as the upper four bits of the previously issued command.
  6. The 7<sup>th</sup> byte indicates whether the Chip Erase command is normally completed or not.

At normal completion, completion code (4FH) is sent.

When an error was detected, error code (4CH) is sent.
  7. The 9th byte is the next command code.

5) Acknowledge Responses

The boot program represents processing states with specific codes. Table 18-10 to Table 18-13 show the values of possible acknowledge responses to the received data. The upper four bits of the acknowledge response are equal to those of the command being executed. Bit 3 of the code indicates a receive error. Bit 0 indicates an invalid command error, a checksum error or a password error. Bit 1 and bit 2 are always 0. Receive error checking is not done in I/O Interface mode.

**Table 18-10 ACK Response to the Serial Operation Mode Byte**

Return Value	Meaning
0x86	The SIO can be configured to operate in UART mode. (See Note)
0x30	The SIO can be configured to operate in I/O Interface mode.

**(Note) If the serial operation mode is determined as UART, the boot program checks if the SIO can be programmed to the baud rate at which the operation mode byte was transferred. If that baud rate is not possible, the boot program aborts, without sending back any response.**

**Table 18-11 ACK Response to the Command Byte**

Return Value	Meaning
0x?8 (See Note)	A receive error occurred while getting a command code.
0x?1 (See Note)	An undefined command code was received. (Reception was completed normally.)
0x10	The RAM Transfer command was received.
0x20	The Show Flash Memory Sum command was received.
0x30	The Show Product Information command was received.
0x40	The Chip Erase command was received.

**(Note) The upper four bits of the ACK response are the same as those of the previous command code.**

**Table 18-12 ACK Response to the Checksum Byte**

Return Value	Meaning
0xN8 (See Note)	A receive error occurred.
0xN1 (See Note)	A checksum or password error occurred.
0xN0 (See Note)	The checksum was correct.

**(Note) The upper four bits of the ACK response are the same as those of the operation command code. It is 1 ( N=RAM transfer command data [7:4] ) when password error occurs.**

**Table 18-13 ACK Response to Chip and Protection Bit Erase Byte**

Return Value	Meaning
54H	The Chip Erase enabling command was received.
4FH	The Chip Erase command was completed.
4CH	The Chip Erase command was abnormally completed.

## 6) Determination of a Serial Operation Mode

The first byte from the controller determines the serial operation mode. To use UART mode for communications between the controller and the target board, the controller must first send a value of 86H at a desired baud rate to the target board. To use I/O Interface mode, the controller must send a value of 30H at 1/16 the desired baud rate. Fig. 18-4 shows the waveforms for the first byte.

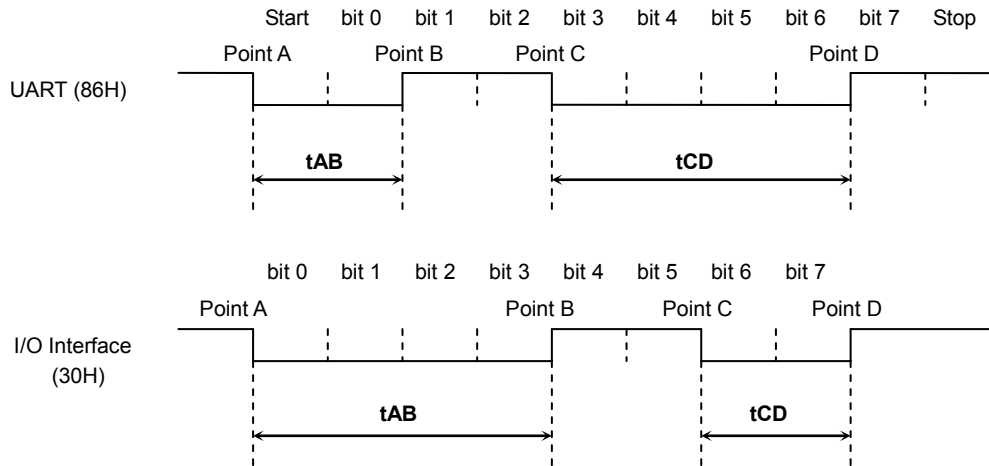

**Fig. 18-4 Serial Operation Mode Byte**

After  $\overline{\text{RESET}}$  is released, the boot program monitors the first serial byte from the controller, with the SIO reception disabled, and calculates the intervals of t<sub>AB</sub>, t<sub>AC</sub> and t<sub>AD</sub>. Fig. 18-5 shows a flowchart describing the steps to determine the intervals of t<sub>AB</sub>, t<sub>AC</sub> and t<sub>AD</sub>. As shown in the flowchart, the boot program captures timer counts each time a logic transition occurs in the first serial byte. Consequently, the calculated t<sub>AB</sub>, t<sub>AC</sub> and t<sub>AD</sub> intervals are bound to have slight errors. If the transfer goes at a high baud rate, the CPU might not be able to keep up with the speed of logic transitions at the serial receive pin. In particular, I/O Interface mode is more prone to this problem since its baud rate is generally much higher than that for UART mode. To avoid such a situation, the controller should send the first serial byte at 1/16 the desired baud rate.

The flowchart in Fig. 18-5 shows how the boot program distinguishes between UART and I/O Interface modes. If the length of t<sub>AB</sub> is equal to or less than the length of t<sub>CD</sub>, the serial operation mode is determined as UART mode. If the length of t<sub>AB</sub> is greater than the length of t<sub>CD</sub>, the serial operation mode is determined as I/O Interface mode. Bear in mind that if the baud rate is too high or the timer operating frequency is too low, the timer resolution will be coarse, relative to the intervals between logic transitions. This becomes a problem due to inherent errors caused by the way in which timer counts are captured by software; consequently the boot program might not be able to determine the serial operation mode correctly. To prevent this problem, reset UART mode within the programming routine.

For example, the serial operation mode may be determined to be I/O Interface mode when the intended mode is UART mode. To avoid such a situation, when UART mode is utilized, the controller should allow for a time-out period within which it expects to receive an echo-back (86H) from the target board. The controller should give up the communication if it fails to get that echo-back within the allowed time. When I/O Interface mode is utilized, once the first serial byte has been transmitted, the controller should send the SCLK clock after a certain idle time to get an acknowledge response. If the received acknowledge response is not 30H, the controller should give up further communications.

When the intended mode is I/O interface mode, the first byte does not have to be 0x30 as long as  $t_{AB}$  is greater than  $t_{CD}$  as shown above. 0x91, 0xA1 or 0xB1 can be sent as the first byte code to determine the falling edges of Point A and Point C and the rising edges of Point B and Point D. If  $t_{AB}$  is greater than  $t_{CD}$  and SIO is selected by the resolution of the operation mode determination, the second byte code is 0x30 even though the transmitted code on the first byte is not 0x30 (The first byte code to determine I/O interface mode is described as 0x30).

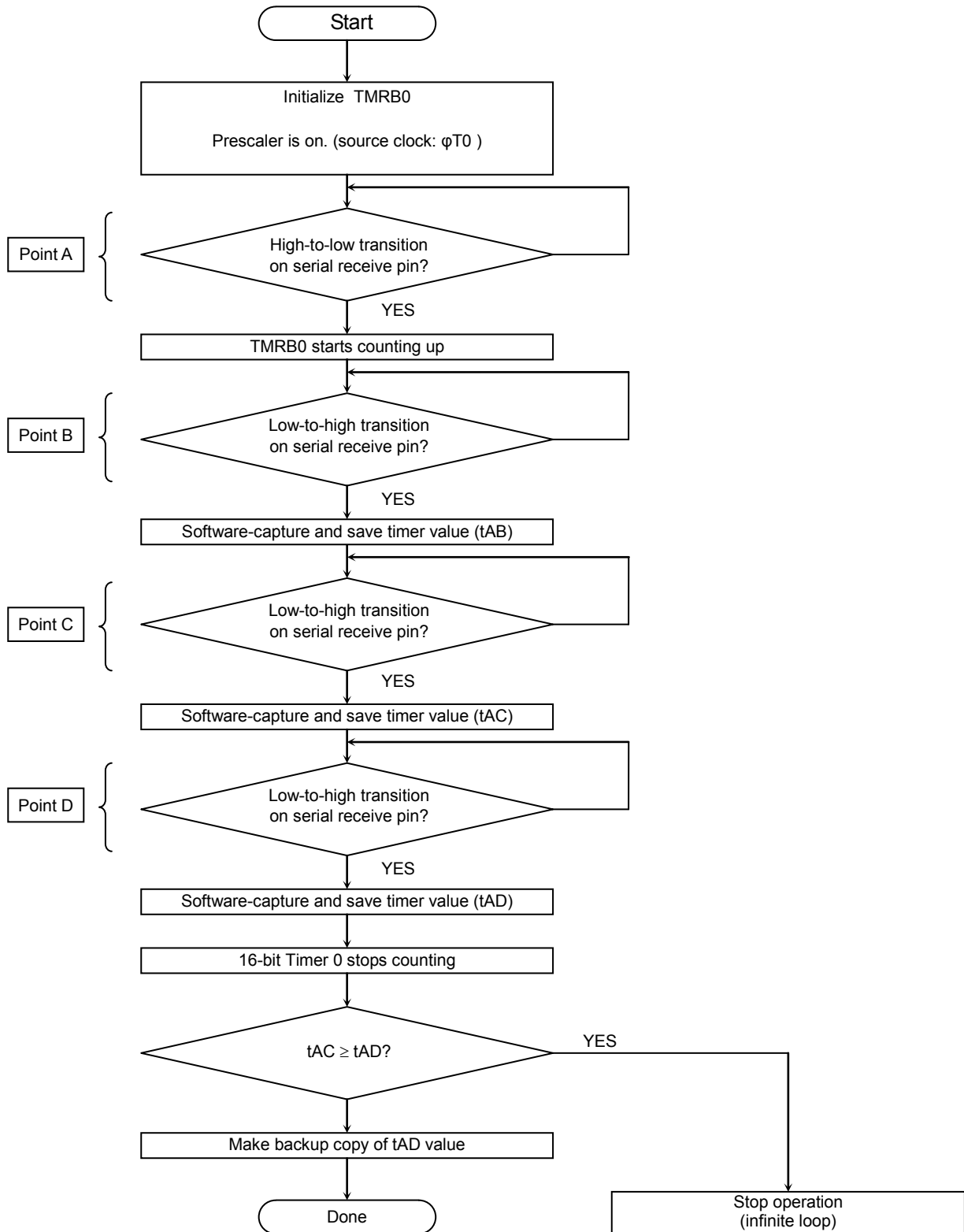
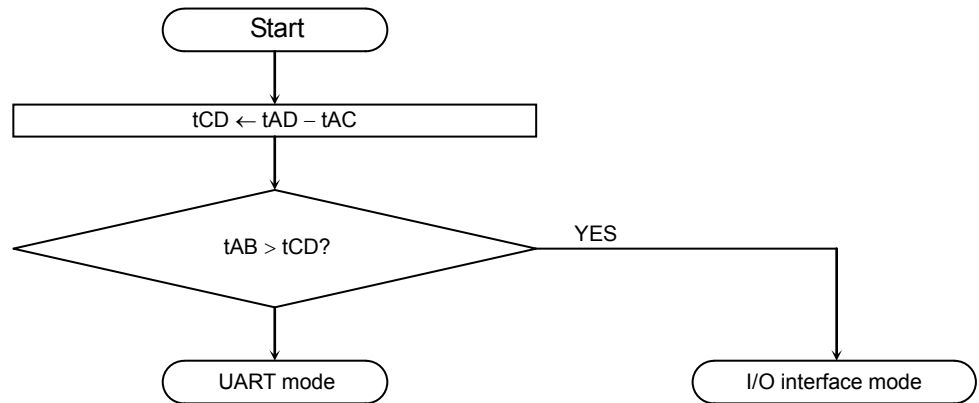

Fig. 18-5 Serial Operation Mode Byte Reception Flow



**Fig. 18-6 Serial Operation Mode Determination Flow**

### 7) Password

The RAM Transfer command (10H) causes the boot program to perform password verification. Following an echo-back of the command code, the boot program verifies the contents of the 12-byte password area within the flash memory.

Product name	Area
TMPM330FYWFG	0x3F87_FF04 – 0x3F87_FF0F

If all these address locations contain the same bytes of data other than FFH, a password area error occurs as shown in Fig. 18-7. In this case, the boot program returns an error acknowledge (11H) in response to the checksum byte (the 17th byte), regardless of whether the password sequence sent from the controller is all FFHs.

The password sequence received from the controller (5th to 16th bytes) is compared to the password stored in the flash memory. All of the 12 bytes must match to pass the password verification. Otherwise, a password error occurs, which causes the boot program to reply an error acknowledge in response to the checksum byte (the 17th byte).

The password verification is performed even if the security function is enabled.

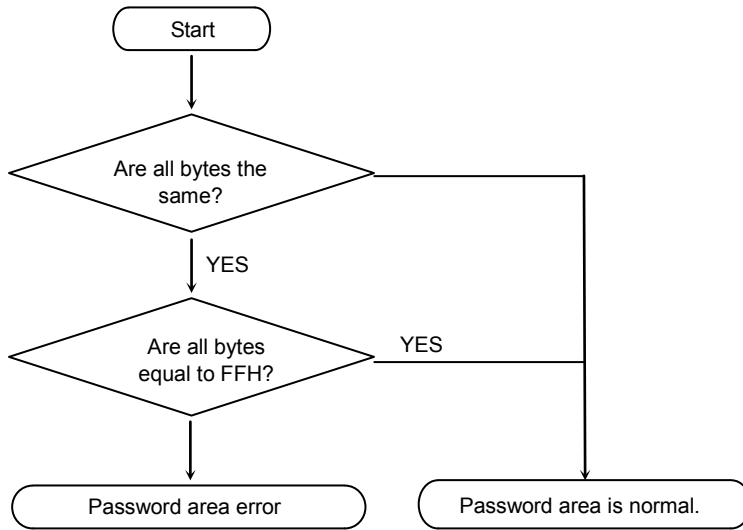

Fig. 18-7 Password Area Verification Flow

## 8) Calculation of the Show Flash Memory Sum Command

The result of the sum calculation “byte + byte + byte + ...” is responded by a word quantity. The Show Flash Memory Sum command adds all 512 Kbytes of the flash memory together and provides the total sum as a word quantity. The sum is sent to the controller, with the upper eight bits first, followed by the lower eight bits.

**Note: In the TMP330FYWFG, the range from 256KB through the password area and from the password area through 0x007\_FFFF area are calculated as "0xFF".**

Example)

A1H
B2H
C3H
D4H

For the interest of simplicity, assume the depth of the flash memory is four locations. Then the sum of the four bytes is calculated as:

$$A1H + B2H + C3H + D4H = 02EAH$$

Hence, 02H is first sent to the controller, followed by EAH.

## 9) Checksum Calculation

The checksum byte for a series of bytes of data is calculated by adding the bytes together, dropping the carries, and taking the two's complement of the total sum. The Show Flash Memory Sum command and the Show Product Information command perform the checksum calculation. The controller must perform the same checksum operation in transmitting checksum bytes.

Example) Assume the Show Flash Memory Sum command provides the upper and lower bytes of the sum as E5H and F6H. To calculate the checksum for a series of E5H and F6H:

Add the bytes together

$$E5H + F6H = 1DBH$$

Take the two's complement of the sum, and that is the checksum byte.

$$0 - DBH = 25H$$

(7) General Boot Program Flowchart

Fig. 18-8 shows an overall flowchart of the boot program.

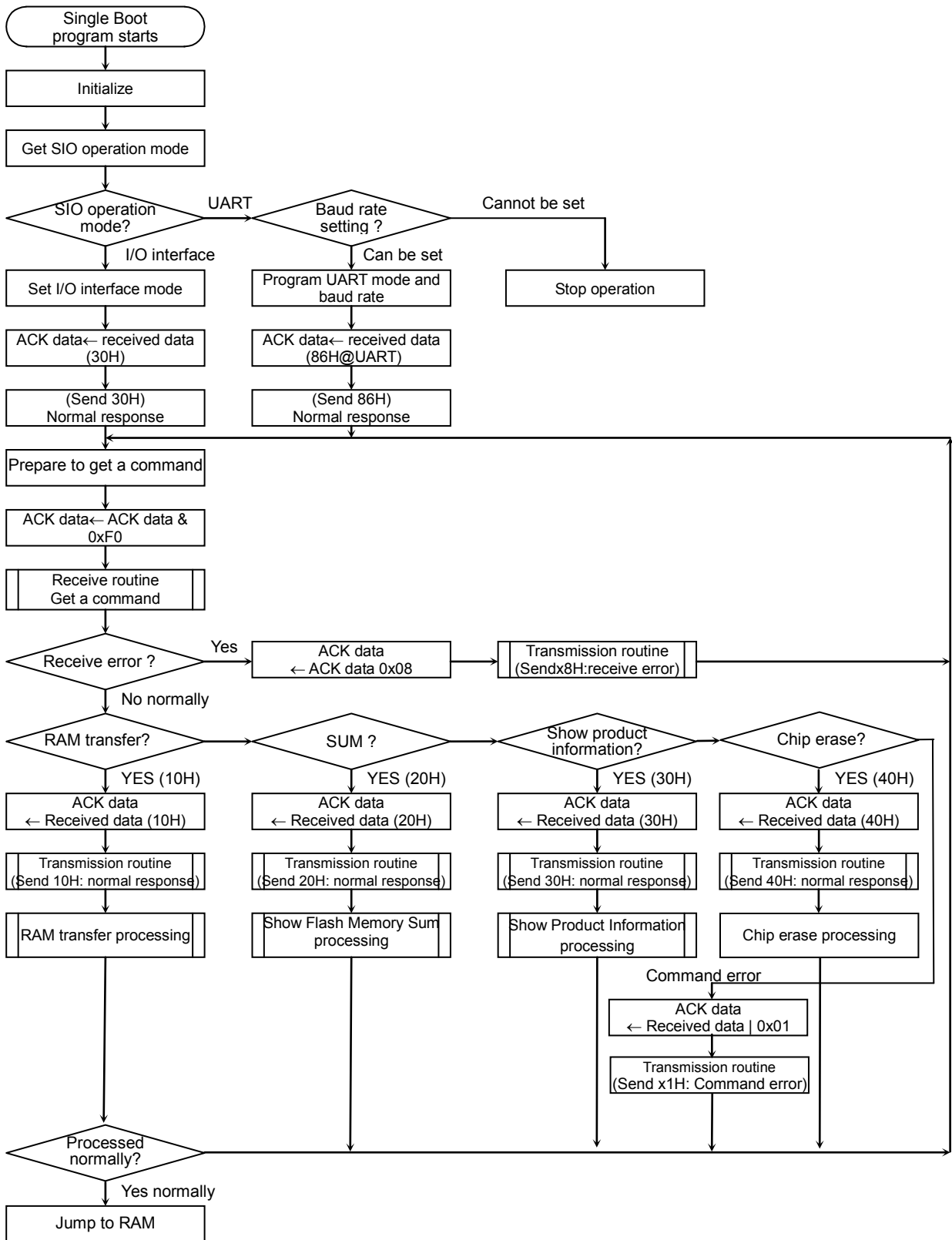

Fig. 18-8 Overall Boot Program Flow

### 18.3 On-board Programming of Flash Memory (Rewrite/Erase)

In on-board programming, the CPU is to execute software commands for rewriting or erasing the flash memory. The rewrite/erase control program should be prepared by the user beforehand. Because the flash memory content cannot be read while it is being written or erased, it is necessary to run the rewrite/erase program from the internal RAM or from an external memory device after shifting to the user boot mode.

#### 18.3.1 Flash Memory

Except for some functions, writing and erasing flash memory data are in accordance with the standard JEDEC commands. In writing or erasing, use 32-bit data transfer command of the CPU to enter commands to the flash memory. Once the command is entered, the actual write or erase operation is automatically performed internally.

**Table 18-14 Flash Memory Functions**

Major functions	Description
Automatic page program	Writes data automatically per page.
Automatic chip erase	Erases the entire area of the flash memory automatically.
Automatic block erase	Erases a selected block automatically.
Protect function	By writing a 4-bit protection code, the write or erase function can be individually inhibited for each block.

Note that addressing of operation commands is different from the case of standard commands due to the specific interface arrangements with the CPU. Also note that the flash memory is written in 32-bit blocks. So, 32-bit (word) data transfer commands must be used in writing the flash memory.

(1) Block configuration

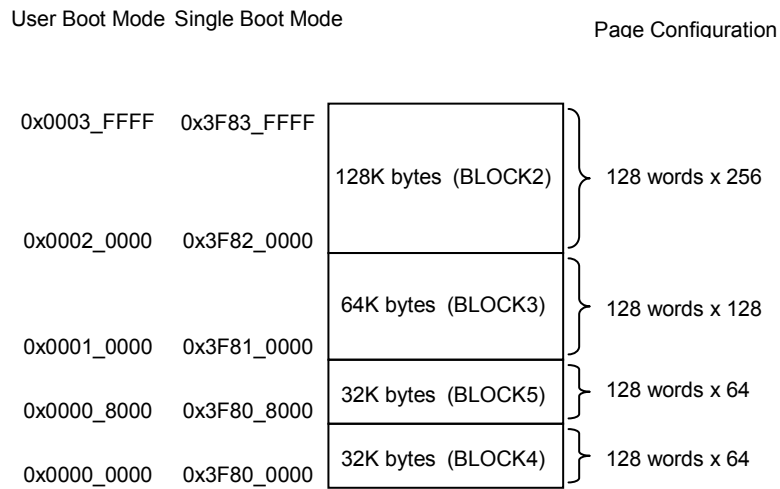

Fig. 18-9 Block Configuration of Flash Memory

**(Note)** In addition to 256KB flash area, the TMPM330FYWFG provides 128-word data/password area (0x3F87\_FE00 – 0x3F87\_FFFF, 1 page) for Show Product Information command. To erase the content, execute the automatic chip erase command or assign block 0 with the automatic block erase command.

## (2) Basic operation

Generally speaking, this flash memory device has the following two operation modes:

- The mode to read memory data (Read mode)
- The mode to automatically erase or rewrite memory data (Automatic operation)

Transition to the automatic mode is made by executing a command sequence while it is in the memory read mode. In the automatic operation mode, flash memory data cannot be read and any commands stored in the flash memory cannot be executed. In the automatic operation mode, any interrupt or exception generation cannot set the device to the read mode except when a hardware reset is generated. During automatic operation, be sure not to cause any exceptions other than debug exceptions and reset while a debug port is connected. Any exception generation cannot set the device to the read mode except when a hardware reset is generated.

### 1) Read

When data is to be read, the flash memory must be set to the read mode. The flash memory will be set to the read mode immediately after power is applied, when CPU reset is removed, or when an automatic operation is normally terminated. In order to return to the read mode from other modes or after an automatic operation has been abnormally terminated, either the Read/reset command (a software command to be described later) or a hardware reset is used. The device must also be in the read mode when any command written on the flash memory is to be executed.

- **Read/reset command and Read command (software reset)**

When ID-Read command is used, the reading operation is terminated instead of automatically returning to the read mode. In this case, the Read/reset command can be used to return the flash memory to the read mode. Also, when a command that has not been completely written has to be canceled, the Read/reset command must be used. The Read command is used to return to the read mode after executing 32-bit data transfer command to write the data "0x0000\_00F0" to an arbitrary address of the flash memory.

- **With the Read/reset command, the device is returned to the read mode after completing the third bus write cycle.**

### 2) Command write

This flash memory uses the command control method. Commands are executed by executing a command sequence to the flash memory. The flash memory executes automatic operation commands according to the address and data combinations applied (refer to Command Sequence).

If it is desired to cancel a command write operation already in progress or when any incorrect command sequence has been entered, the Read/reset command is to be executed. Then, the flash memory will terminate the command execution and return to the read

While commands are generally comprised of several bus cycles, the operation to apply 32-bit data transmit command to the flash memory is called "bus write cycle." The bus write cycles are to be in a specific sequential order and the flash memory will perform an automatic operation when the sequence of the bus write cycle data and address of a

command write operation is in accordance with a predefined specific sequence. If any bus write cycle does not follow a predefined command write sequence, the flash memory will terminate the command execution and return to the read mode.

**(Note 1) Command sequences are executed from outside the flash memory area.**

**(Note 2) Each bus write cycle must be sequentially executed by 32-bit data transmit command. While a command sequence is being executed, access to the flash memory is prohibited. Also, don't generate any interrupt (except debug exceptions when a DSU probe is connected). If such an operation is made, it can result in an unexpected read access to the flash memory and the command sequencer may not be able to correctly recognize the command. While it could cause an abnormal termination of the command sequence, it is also possible that the written command is incorrectly recognized.**

**(Note 3) For the command sequencer to recognize a command, the device must be in the read mode prior to executing the command. Be sure to check before the first bus write cycle that the FCFLCS RDY/BSY bit is set to "1." It is recommended to subsequently execute a Read command.**

**(Note 4) Upon issuing a command, if any address or data is incorrectly written, be sure to perform a software reset to return to the read mode again.**

### (3) Reset

#### Hardware reset

A hardware reset is used to cancel the operational mode set by the command write operation when forcibly termination during auto programming/ erasing or abnormal termination during auto operations occurs. The flash memory has a reset input as the memory block and it is connected to the CPU reset signal. Therefore, when the RESET input pin of this device is set to  $V_{IL}$  or when the CPU is reset due to any overflow of the watch dog timer, the flash memory will return to the read mode terminating any automatic operation that may be in progress. It should also be noted that applying a hardware reset during an automatic operation can result in incorrect rewriting of data. In such a case, be sure to perform the rewriting again.

Refer to Section 18.2.1 "Reset Operation" for CPU reset operations. After a given reset input, the CPU will read the reset vector data from the flash memory and starts operation after the reset is removed.

## (4) Commands

## 1) Automatic Page Programming

Writing to a flash memory device is to make "1" data cells to "0" data cells. Any "0" data cell cannot be changed to a "1" data cell. For making "0" data cells to "1" data cells, it is necessary to perform an erase operation.

The automatic page programming function of this device writes data of each page. The TMPM330 contains 128 words in a page. A 128 word block is defined by a same [31:9] address and it starts from the address [8:0] = 0 and ends at the address [8:0] = 0x1FF. A 64 word block is defined by a same [31:8] address and it starts from the address [7:0] = 0 and ends at the address [7:0] = 0xFF. This programming unit is hereafter referred to as a "page."

Writing to data cells is automatically performed by an internal sequencer and no external control by the CPU is required. The state of automatic page programming (whether it is in writing operation or not) can be checked by the FCFLCS [0] <RDY/BSY> register.

Also, any new command sequence is not accepted while it is in the automatic page programming mode. If it is desired to interrupt the automatic page programming, use the hardware reset function. If the operation is stopped by a hardware reset operation, it is necessary to once erase the page and then perform the automatic page programming again because writing to the page has not been normally terminated.

The automatic page programming operation is allowed only once for a page already erased. No programming can be performed twice or more times irrespective of the data cell value whether it is "1" or "0." Note that rewriting to a page that has been once written requires execution of the automatic block erase or automatic chip erase command before executing the automatic page programming command again. Note that an attempt to rewrite a page two or more times without erasing the content can cause damages to the device.

No automatic verify operation is performed internally to the device. So, be sure to read the data programmed to confirm that it has been correctly written.

The automatic page programming operation starts when the third bus write cycle of the command cycle is completed. On and after the fifth bus write cycle, data will be written sequentially starting from the next address of the address specified in the fourth bus write cycle (in the fourth bus write cycle, the page top address will be command written) (32 bits of data is input at a time). Be sure to use the 32-bit data transfer command in writing commands on and after the fourth bus cycle. In this, any 32-bit data transfer commands shall not be placed across word boundary. On and after the fifth bus write cycle, data is command written to the same page area. Even if it is desired to write the page only partially, it is required to perform the automatic page programming for the entire page. In this case, the address input for the fourth bus write cycle shall be set to the top address of the page. Be sure to perform command write operation with the input data set to "1" for the data cells not to be set to "0." For example, if the top address of a page is not to be written, set the input data of the fourth bus write cycle to 0xFFFFFFFF to command write the data.

Once the fourth bus cycle is executed, it is in the automatic programming operation. This condition can be checked by monitoring the register bit FCFLCS [0] <RDY/BSY> (See Table 18-15). Any new command sequence is not accepted while it is in automatic page programming mode. If it is desired to stop operation, use the hardware reset function. Be careful in doing so because data cannot be written normally if the operation is interrupted.

When a single page has been command written normally terminating the automatic page writing process, the FCFLCS [0] <RDY/BSY> bit is set to "1" and it returns to the read mode.

When multiple pages are to be written, it is necessary to execute the page programming command for each page because the number of pages to be written by a single execution of the automatic page program command is limited to only one page. It is not allowed for automatic page programming to process input data across pages.

Data cannot be written to a protected block. When automatic programming is finished, it automatically returns to the read mode. This condition can be checked by monitoring FCFLCS [0] <RDY/BSY> (Table 18-15). If automatic programming has failed, the flash memory is locked in the mode and will not return to the read mode. For returning to the read mode, it is necessary to execute hardware reset to reset the flash memory or the device. In this case, while writing to the address has failed, it is recommended not to use the device or not to use the block that includes the failed address.

**(Note) Software reset becomes ineffective in bus write cycles on and after the fourth bus write cycle of the automatic page programming command.**

## 2) Automatic chip erase

The automatic chip erase operation starts when the sixth bus write cycle of the command cycle is completed.

This condition can be checked by monitoring FCFLCS [0] <RDY/BSY> (See Table 18-15). While no automatic verify operation is performed internally to the device, be sure to read the data to confirm that data has been correctly erased. Any new command sequence is not accepted while it is in an automatic chip erase operation. If it is desired to stop operation, use the hardware reset function. If the operation is forced to stop, it is necessary to perform the automatic chip erase operation again because the data erasing operation has not been normally terminated.

Also, any protected blocks cannot be erased. If all the blocks are protected, the automatic chip erase operation will not be performed and it returns to the read mode after completing the sixth bus read cycle of the command sequence. When an automatic chip erase operation is normally terminated, it automatically returns to the read mode. If an automatic chip erase operation has failed, the flash memory is locked in the mode and will not return to the read mode.

For returning to the read mode, it is necessary to execute hardware reset to reset the device. In this case, the failed block cannot be detected. It is recommended not to use the device anymore or to identify the failed block by using the block erase function for not to use the identified block anymore.

## 3) Automatic block erase (for each block)

The automatic block erase operation starts when the sixth bus write cycle of the command cycle is completed.

This status of the automatic block erase operation can be checked by monitoring FCFLCS <RDY/BSY> (See Table 18-15). While no automatic verify operation is performed internally to the device, be sure to read the data to confirm that data has been correctly erased. Any new command sequence is not accepted while it is in an automatic block erase operation. If it is desired to stop operation, use the hardware reset function. In this case, it is necessary to perform the automatic block erase operation again because the data erasing operation has not been normally terminated.

Also, any protected blocks cannot be erased. If an automatic block erase operation has failed, the flash memory is locked in the mode and will not return to the read mode. In this case, execute hardware reset to reset the device.

4) Automatic programming of protection bits (for each block)

This device is implemented with protection bits. This protection can be set for each block. See Table 18-20 for table of protection bit addresses. This device assigns 1 bit to 1 block as a protection bit. The applicable protection bit is specified by PBA in the seventh bus write cycle. By automatically programming the protection bits, write and/or erase functions can be inhibited (for protection) individually for each block. The protection status of each block can be checked by the FCFLCS <BLPRO> register to be described later. This status of the automatic programming operation to set protection bits can be checked by monitoring FCFLCS <RDY/BSY> (See Table 18-15). Any new command sequence is not accepted while automatic programming is in progress to program the protection bits. If it is desired to stop the programming operation, use the hardware reset function. In this case, it is necessary to perform the programming operation again because the protection bits may not have been correctly programmed. If all the protection bits have been programmed, all the FCFLCS <BLPRO> bits are set to "1" indicating that it is in the protected state (See Table 18-15). This disables subsequent writing and erasing of all blocks.

**(Note) Software reset is ineffective in the seventh bus write cycle of the automatic protection bit programming command. The FCFLCS <RDY/BSY> bit turns to "0" after entering the seventh bus write cycle.**

## 5) Automatic erasing of protection bits

Different results will be obtained when the automatic protection bit erase command is executed depending on the status of the protection bits and the security bits. It depends on the status of FCFLCS <BLPRO> whether all the <BLPRO> bits are set to "1" or not if FCSECBIT<SECBIT> is 0x1. Be sure to check the value of FCFLCS <BLPRO> before executing the automatic protection bit erase command. See chapter 17 for details.

**(Note) The TMPM330FYWFG is configured with block 2 through 5. Block 0 and 1 require a programming of protection bits when using security function.**

**· When all the FCFLCS <BLPRO> bits are set to "1" (all the protection bits are programmed):**

When the automatic protection bit erase command is command written, the flash memory is automatically initialized within the device. When the seventh bus write cycle is completed, the entire area of the flash memory data cells is erased and then the protection bits are erased. This operation can be checked by monitoring FCFLCS <RDY/BSY>. If the automatic operation to erase protection bits is normally terminated, FCFLCS will be set to "0x00000001." While no automatic verify operation is performed internally to the device, be sure to read the data to confirm that it has been correctly erased. For returning to the read mode while the automatic operation after the seventh bus cycle is in progress, it is necessary to use the hardware reset to reset the device. If this is done, it is necessary to check the status of protection bits by FCFLCS <BLPRO> after retuning to the read mode and perform either the automatic protection bit erase, automatic chip erase, or automatic block erase operation, as appropriate.

**· When the FCFLCS <BLPRO> bits include "0" (not all the protection bits are programmed):**

The protection condition can be canceled by the automatic protection bit erase operation. With this device, protection bits set by an individual block can be erased handling all the blocks at a time as shown in Table 18-21. The target bits are specified in the seventh bus write cycle and when the command is completed, the device is in a condition all the blocks are erased. The protection status of each block can be checked by FCFLCS <BLPRO> to be described later. This status of the programming operation for automatic protection bits can be checked by monitoring FCFLCS <RDY/BSY>. When the automatic operation to erase protection bits is normally terminated, the protection bits of FCFLCS <BLPRO> selected for erasure are set to "0."

In any case, any new command sequence is not accepted while it is in an automatic operation to erase protection bits. If it is desired to stop the operation, use the hardware reset function. When the automatic operation to erase protection bits is normally terminated, it returns to the read mode.

**(Note) The FCFLCS <RDY/BSY> bit is "0" while in automatic operation and it turns to "1" when the automatic operation is terminated.**

## 6) ID-Read

Using the ID-Read command, you can obtain the type and other information on the flash memory contained in the device. The data to be loaded will be different depending on the address [15:14] of the fourth and subsequent bus write cycles (recommended input data is 0x00). On and after the fourth bus write cycle, when an arbitrary flash memory area is read, the ID value will be loaded. Once the fourth bus write cycle of an ID-Read command has passed, the device will not automatically return to the read mode. In this condition, the set of the fourth bus write cycle and ID-Read commands can be repetitively executed. For returning to the read mode, use the Read/reset command or hardware reset command.

(5) Flash control/ status register

This register is used to monitor the status of the flash memory and to indicate the protection status of each block.

**Table 18-15 Flash Control Register**

FCFLCS  
0x4004\_0520

	31	30	29	28	27	26	25	24
bit Symbol	-	-	-	-	-	-	-	-
Read/Write	R							
After reset	0							
Function	"0" is read.							
	23	22	21	20	19	18	17	16
bit Symbol	-	-	BLPRO5	BLPRO4	BLPRO3	BLPRO2	BLPRO1	BLPRO0
Read/Write	R		R	R	R	R	R	R
After reset	0		(Note 2)	(Note 2)	(Note 2)	(Note 2)	(Note 2)	(Note 2)
Function	"0" is read.		Protection for Block 5 0: disabled 1: enabled	Protection for Block 4 0: disabled 1: enabled	Protection for Block 3 0: disabled 1: enabled	Protection for Block 2 0: disabled 1: enabled	Protection for Block 1 0: disabled 1: enabled	Protection for Block 0 0: disabled 1: enabled
	15	14	13	12	11	10	9	8
bit Symbol	-	-	-	-	-	-	-	-
Read/Write	R							
After reset	0							
Function	"0" is read.							
	7	6	5	4	3	2	1	0
bit Symbol	-	-	-	-	-	-	-	RDY/BSY
Read/Write	R							R
After reset	0							1
Function	"0" is read.							Ready/Busy (Note 1) 0: Auto operating 1: Auto operation terminated

Bit 0: Ready/Busy flag bit

The RDY/BSY output is provided as a means to monitor the status of automatic operation. This bit is a function bit for the CPU to monitor the function. When the flash memory is in automatic operation, it outputs "0" to indicate that it is busy. When the automatic operation is terminated, it returns to the ready state and outputs "1" to accept the next command. If the automatic operation has failed, this bit maintains the "0" output. By applying a hardware reset, it returns to "1."

Bit [21:16]: Protection status bits

Each of the protection bits represents the protection status of the corresponding block. When a bit is set to "1," it indicates that the block corresponding to the bit is protected. When the block is protected, data cannot be written to it.

**(Note 1)** This command must be issued in the ready state. Issuing the command in the busy state may disable both correct command transmission and further command input. To exit from the condition, execute system reset. System reset requires at least 0.5 microseconds regardless of the system clock frequency. In this condition, it takes approx. 2 ms to enable reading after reset.

**(Note 2)** The value varies depending on protection applied.

**Table 18-16 Security bit register**

FCSECBIT  
0x4004\_0500

	31	30	29	28	27	26	25	24
bit Symbol	-	-	-	-	-	-	-	-
Read/Write	R							
After reset	0							
Function	"0" is read							
	23	22	21	20	19	18	17	16
bit Symbol	-	-	-	-	-	-	-	-
Read/Write	R							
After reset	0							
Function	"0" is read							
	15	14	13	12	11	10	9	8
bit Symbol	-	-	-	-	-	-	-	-
Read/Write	R							
After reset	0							
Function	"0" is read							
	7	6	5	4	3	2	1	0
bit Symbol	-	-	-	-	-	-	-	SECBIT
Read/Write	R							R/W
After reset	0							1
Function	"0" is read							Security bits 0:disabled 1:enabled

**(Note)** This register is initialized only by power-on reset.

## (6) List of Command Sequences

**Table 18-17 Flash Memory Access from the Internal CPU**

Command sequence	First bus cycle	Second bus cycle	Third bus cycle	Fourth bus cycle	Fifth bus cycle	Sixth bus cycle	Seventh bus cycle
	Addr.	Addr.	Addr.	Addr.	Addr.	Addr.	Addr.
	Data	Data	Data	Data	Data	Data	Data
Read	0xXX	—	—	—	—	—	—
	0xF0	—	—	—	—	—	—
Read/Reset	0x54XX	0xAAXX	0x54XX	RA	—	—	—
	0xAA	0x55	0xF0	RD	—	—	—
ID-Read	0x54XX	0xAAXX	0x54XX	IA	0xXX	—	—
	0xAA	0x55	0x90	0x00	ID	—	—
Automatic page programming	0x54XX	0xAAXX	0x54XX	PA	PA	PA	PA
	0xAA	0x55	0xA0	PD0	PD1	PD2	PD3
Automatic chip erase	0x54XX	0xAAXX	0x54XX	0x54XX	0xAAXX	0x54XX	—
	0xAA	0x55	0x80	0xAA	0x55	0x10	—
Auto Block erase	0x54XX	0xAAXX	0x54XX	0x54XX	0xAAXX	BA	—
	0xAA	0x55	0x80	0xAA	0x55	0x30	—
Protection bit programming	0x54XX	0xAAXX	0x54XX	0x54XX	0xAAXX	0x54XX	PBA
	0xAA	0x55	0x9A	0xAA	0x55	0x9A	0x9A
Protection bit erase	0x54XX	0xAAXX	0x54XX	0x54XX	0xAAXX	0x54XX	PBA
	0xAA	0x55	0x6A	0xAA	0x55	0x6A	0x6A

## Supplementary explanation

- RA: Read address
- RD: Read data
- IA: ID address
- ID: ID data
- PA: Program page address  
PD: Program data (32 bit data)  
After the fourth bus cycle, enter data in the order of the address for a page.
- BA: Block address
- PBA: Protection bit address

**(Note 1)** Always set "0" to the address bits [1:0] in the entire bus cycle. (Recommendable setting values to bits [7:2] are "0".)

**(Note 2)** Bus cycles are "bus write cycles" except for the second bus cycle of the Read command, the fourth bus cycle of the Read/reset command, and the fifth bus cycle of the ID-Read command. Bus write cycles are executed by 32-bit data transfer commands. The address [31:16] in each bus write cycle should be the target flash memory address [31:16] of the command sequence. Use "Addr." in the table for the address [15:0].

(7) Address bit configuration for bus write cycles

**Table 18-18 Address Bit Configuration for Bus Write Cycles**

Address	Addr [31:19]	Addr [18]	Addr [17]	Addr [16]	Addr [15]	Addr [14]	Addr [13:11]	Addr [10]	Addr [9]	Addr [8]	Addr [7:0]
Normal commands	<b>Normal bus write cycle address configuration</b>										
	Flash area	"0" is recommended.				Command				Addr[1:0]="0" (fixed) Others:0 (recommended)	
ID -READ	<b>IA: ID address (Set the fourth bus write cycle address for ID-Read operation)</b>										
	Flash area	"0" is recommended.		ID address		Addr[1:0]="0" (fixed) , Others:0 (recommended)					
Block erase	<b>BA: Block address (Set the sixth bus write cycle address for block erase operation)</b>										
	Block selection (Table 18-19)					Addr[1:0]="0" (fixed) , Others:0 (recommended)					
Auto page programming	<b>PA: Program page address (Set the fourth bus write cycle address for page programming operation)</b>										
	Page selection								Addr[1:0]="0" (fixed) Others:0 (recommended)		
Protection bit programming	<b>PBA: Protection bit address (Set the seventh bus erase cycle address for protection bit erasure)</b>										
	Flash area	Protection bit selection (Table 18-20)			Fixed to "0".			Protection bit selection (Table 18-20)		Addr[1:0]="0" (fixed) Others:0 (recommended)	
Protection bit erase	<b>PBA: Protection bit address (Set the seventh bus erase cycle address for protection bit erasure)</b>										
	Flash area	Protection bit selection (Table 18-21)		"0" is recommended.				Protection bit selection (Table 18-21)		Addr[1:0]="0" (fixed) Others:0 (recommended)	

- (Note 1) Table 18-17 "Flash Memory Access from the Internal CPU" can also be used.
- (Note 2) Address setting can be performed according to the "Normal bus write cycle address configuration" from the first bus cycle.
- (Note 3) "0" is recommended" can be changed as necessary.

**Table 18-19 Block Address Table**

Block	Address (User boot mode)	Address (Single boot mode)	Size (Kbyte)
4	0x0000_0000-0x0000_7FFF	0x3F80_0000-0x3F80_7FFF	32
5	0x0000_8000-0x0000_FFFF	0x3F80_0000-0x3F80_FFFF	32
3	0x0001_0000-0x0001_FFFF	0x3F81_0000-0x3F81_FFFF	64
2	0x0002_0000-0x0003_FFFF	0x3F82_0000-0x3F83_FFFF	128

As block address, specify any address in the block to be erased.

**(Note) As for the addresses from the first to the fifth bus cycles, specify the upper 4 bit with the corresponding flash memory addresses of the blocks to be erased.**

**Table 18-20 Protection Bit Programming Address Table**

Block	Protection bit	The seventh bus write cycle address						
		Address [18]	Address [17]	Address [16]	Address [15:11]	Address [10]	Address [9]	Address [8]
Block0	-	0	0	1	Fixed to "0".	0	0	"0" is recommended.
Block1	-	0	0	1		0	1	
Block2	BLPRO2	0	0	1		1	0	
Block3	BLPRO3	0	0	1		1	1	
Block4	BLPRO4	0	1	0		0	0	
Block5	BLPRO5	0	1	0		0	1	

**Table 18-21 Protection Bit Erase Address Table**

Block	Protection bit	The seventh bus write cycle address [18:17]	
		Address [18]	Address [17]
Block0~3	BLPRO0~3	0	0
Block4~5	BLPRO4~5	0	1

**(Note) The protection bit erase command cannot erase by individual block.**

**Table 18-22 The ID-Read command's fourth bus write cycle ID address (IA) and the data to be read by the following 32-bit data transfer command (ID)**

IA [15:14]	ID [7: 0]	Code
00b	0x98	Manufacturer code
01b	0x5A	Device code
10b	Reserved	---
11b	0x12(TMPM330)	Macro code

(8) Flowchart

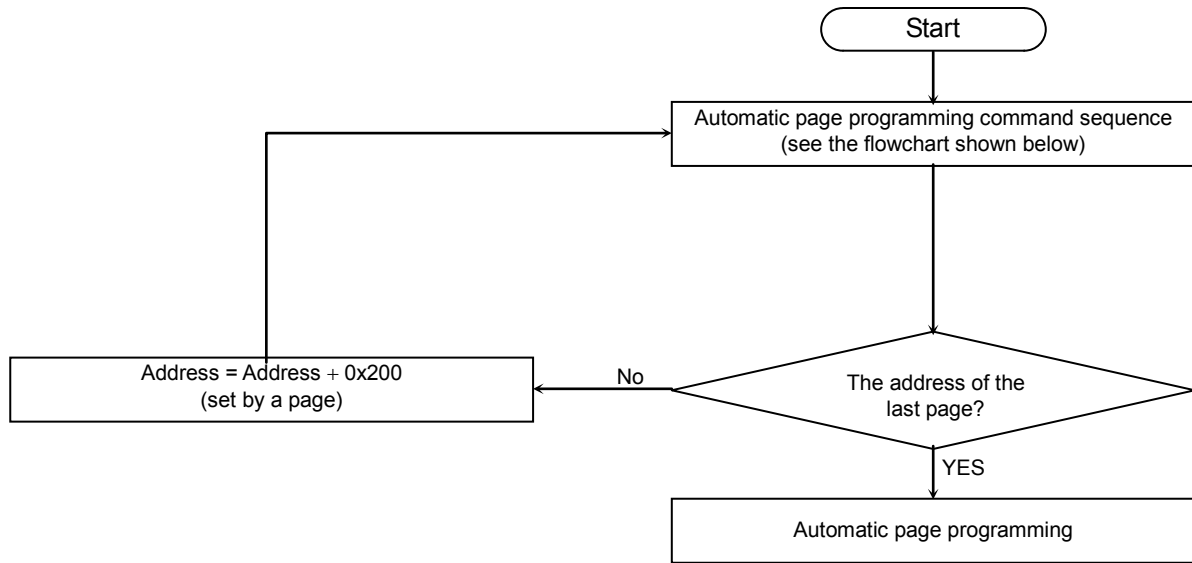

Automatic Page Programming Command Sequence (Address/ Command)

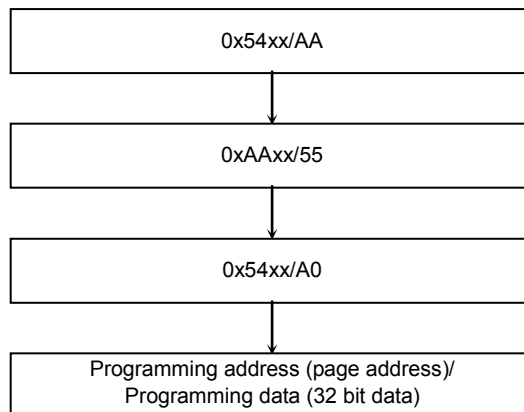

(Note) Command sequence is executed by 0x54xx or 0x55xx.

Fig. 18-10 Automatic Programming

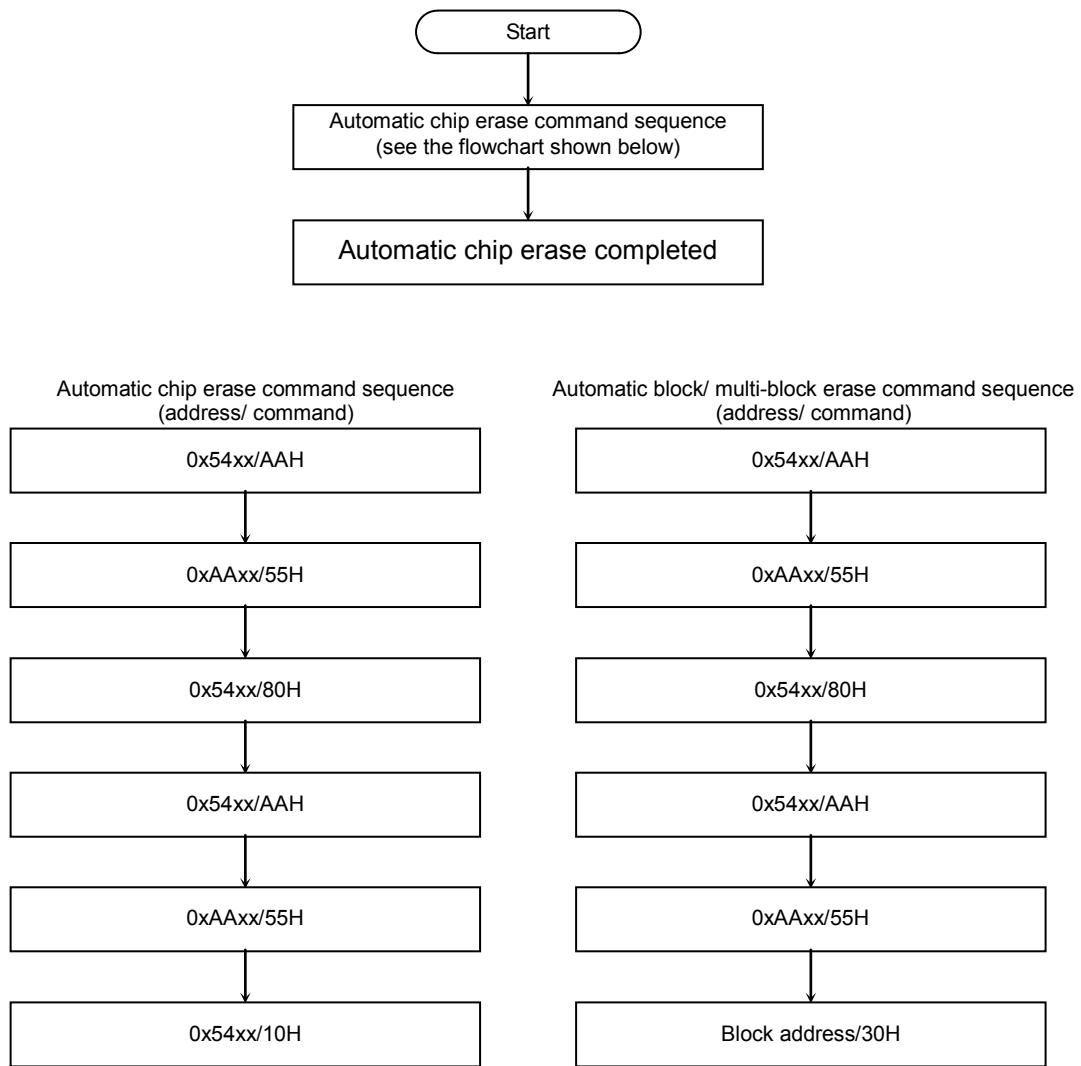

(Note) Command sequence is executed by 0x54xx or 0x55xx.

Fig. 18-11 Automatic Erase

## 19 ROM protection

### 19.1 Outline

The TMPM330 offers two kinds of ROM protection/ security functions. One is a write/ erase-protection function for the internal flash ROM data. The other is a security function that restricts internal flash ROM data readout and debugging.

### 19.2 Features

#### 19.2.1 Write/ erase-protection function

The write/ erase-protection function enables the internal flash to prohibit the writing and erasing operation for each block.

This function is available with a single chip mode, single boot mode and writer mode. To activate the function, write “1” to the corresponding bits to a block to protect. Writing “0” to the bits cancels the protection. The protection settings of the bits can be monitored by the FCFLCS <BLPRO> bit. See chapter 21 for programming details.

#### 19.2.2 Security function

The security function restricts flash ROM data readout and debugging. This function is available under the conditions shown below.

- 1) The FCSECBIT <SECBIT> bit is set to “1”.
- 2) All the protection bits (the FCFLCS<BLPRO> bits) used for the write/erase-protection function are set to “1”.

Note) The FCSECBIT <SECBIT> bit is set to “1” at a power-on reset right after power-on.

Table 19-1 shows details of the restrictions by the security function.

Table 19-1 Restrictions by the security function

Item	Details
1) ROM data readout	Data in the ROM area cannot be read out when writer mode is set. By executing readout, the company code 0x0098 is read. The ROM reading operation is available with a single chip mode and single boot mode.
2) Debug port	Communication of JTAG/SW and trace are prohibited.
3) Command for flash memory	Writing a command to the flash memory is prohibited. An attempt to erase the contents in the bits used for the write/erase-protection erases all the protection bits.

### 19.3 Register

The flash control register shows the status of the flash memory operation and the protection of each block.

Table 19-2 Flash control register

FCFLCS  
0x4004\_0520

	31	30	29	28	27	26	25	24
bit Symbol	-	-	-	-	-	-	-	-
Read/Write	R							
After reset	0							
Function	"0" is read							
	23	22	21	20	19	18	17	16
bit Symbol	-	-	BLPRO5	BLPRO4	BLPRO3	BLPRO2	BLPRO1	BLPRO0
Read/Write	R		R	R	R	R	R	R
After reset	0		(Note 2)	(Note 2)	(Note 2)	(Note 2)	(Note 2)	(Note 2)
Function	"0" is read		Protection for Block 5 0: disabled 1: enabled	Protection for Block 4 0: disabled 1: enabled	Protection for Block 3 0: disabled 1: enabled	Protection for Block 2 0: disabled 1: enabled	Protection for Block 1 0: disabled 1: enabled	Protection for Block 0 0: disabled 1: enabled
	15	14	13	12	11	10	9	8
bit Symbol	-	-	-	-	-	-	-	-
Read/Write	R							
After reset	0							
Function	"0" is read							
	7	6	5	4	3	2	1	0
bit Symbol	-	-	-	-	-	-	-	RDY/BSY
Read/Write	R							R
After reset	0							1
Function	"0" is read							Ready/Busy (Note 1) 0: Auto operating 1: Auto operation terminated

#### Bit 0: Ready/Busy flag bit

The RDY/BSY output is provided as a means to monitor the status of automatic operation. This bit is a function bit for the CPU to monitor the function. When the flash memory is in automatic operation, it outputs "0" to indicate that it is busy. When the automatic operation is terminated, it returns to the ready state and outputs "1" to accept the next command. If the automatic operation has failed, this bit maintains the "0" output. By applying a hardware reset, it returns to "1."

#### Bit [21:16]: Protection status bits

Each of the protection bits (6 bits) represents the protection status of the corresponding block. When a bit is set to "1," it indicates that the block corresponding to the bit is protected. When the block is protected, data cannot be written to it.

**(Note 1)** This command must be issued in the ready state. Issuing the command in the busy state may disable both correct command transmission and further command input. To exit from the condition, execute system reset. System reset requires at least 0.5 microseconds regardless of the system clock frequency. In this condition, it takes approx. 2 ms to enable reading after reset.

**(Note 2)** The value varies depending on protection applied.

Table 19-3 Security bit register

FCSECBIT  
0x4004\_0500

	31	30	29	28	27	26	25	24
bit Symbol	-	-	-	-	-	-	-	-
Read/Write	R							
After reset	0							
Function	"0" is read							
	23	22	21	20	19	18	17	16
bit Symbol	-	-	-	-	-	-	-	-
Read/Write	R							
After reset	0							
Function	"0" is read							
	15	14	13	12	11	10	9	8
bit Symbol	-	-	-	-	-	-	-	-
Read/Write	R							
After reset	0							
Function	"0" is read							
	7	6	5	4	3	2	1	0
bit Symbol	-	-	-	-	-	-	-	SECBIT
Read/Write	R							R/W
After reset	0							1
Function	"0" is read							Security bits 0:disabled 1:enabled

**(Note)** This register is initialized only by power-on reset.

## 19.4 Writing and erasing

### 19.4.1 Protection bits

Writing and erasing protection bits are available with a single chip mode, single boot mode and writer mode.

Writing to the protection bits is done on block-by-block basis.

Erasing of the protection bits is done by two groups of the blocks: block 0 through 3 and block 4 through 5. When the settings for all the blocks are "1", erasing must be done after setting the FCSECBIT <SECBIT> bit to "0". Setting "1" at that situation erases all the protection bits. To write and erase the protection bits, command sequence is used.

See chapter 18 for details.

### 19.4.2 Security bit

Rewriting of the security bits is available with a single chip mode and single boot mode. The FCSECBIT <SECBIT> bit that activates security function is set to "1" at a power-on reset right after power-on. The bit is rewritten by the following procedure.

- 1) Write the code 0xa74a9d23 to FCSECBIT register.
- 2) Write data within 16 clocks from the above.

Note) The above procedure is enabled only when using 32-bit data transfer command.

## 20 Electrical Characteristics

### 20.1 Absolute Maximum Ratings

Parameter		Symbol	Rating	Unit
Supply voltage		DVCC (I/O)	- 0.3~3.9	V
		AVCC (A/D)	- 0.3~3.9	
		CVCC (CLK)	- 0.3~3.9	
		REGVCC	- 0.3~3.9	
Input voltage		$V_{IN}$	- 0.3~ $V_{CC} + 0.3$	V
Low-level output current	Per pin	$I_{OL}$	5	mA
	Total	$\Sigma I_{OL}$	50	
High-level output current	Per pin	$I_{OH}$	- 5	
	Total	$\Sigma I_{OH}$	50	
Power consumption ( $T_a = 85^\circ\text{C}$ )		PD	600	mW
Soldering temperature (10s)		$T_{SOLDER}$	260	$^\circ\text{C}$
Storage temperature		$T_{STG}$	- 55~125	$^\circ\text{C}$
Operating Temperature	Except during Flash W/E	$T_{OPR}$	- 40 ~ 85	$^\circ\text{C}$
	During Flash W/E		0 ~ 70	

**(Note)** Absolute maximum ratings are limiting values of operating and environmental conditions which should not be exceeded under the worst possible conditions. The equipment manufacturer should design so that no Absolute maximum rating value is exceeded with respect to current, voltage, power consumption, temperature, etc. Exposure to conditions beyond those listed above may cause permanent damage to the device or affect device reliability, which could increase potential risks of personal injury due to IC blowup and/or burning.

## 20.2 DC Electrical Characteristics (1/2)

Ta = -40~85°C

Parameter		Symbol	Rating	Min.	Typ. (Note 1)	Max.	Unit
Supply voltage	DVCC = AVCC = CVCC = REGVCC (Note 2) DVSS = AVSS = 0V	DVCC AVCC CVCC REGVCC	fosc = 8 ~ 10MHz fsys = 1 ~ 40MHz Fs = 30 ~ 34KHz	2.7	-	3.6	V
	Low-level input voltage	PC, PD	V <sub>IL1</sub>	2.7V ≤ AVCC ≤ 3.6V	-0.3	-	0.3 AVCC
Normal port		V <sub>IL2</sub>	2.7V ≤ DVCC ≤ 3.6V	0.3 DVCC			
Schmitt-Triggered port		V <sub>IL3</sub>		0.2 DVCC			
X1		V <sub>IL4</sub>	2.7V ≤ CVCC ≤ 3.6V	0.1 CVCC			
High-level input voltage	PC, PD	V <sub>IH1</sub>	2.7V ≤ AVCC ≤ 3.6V	0.7 AVCC	-	AVCC+0.3	V
	Normal port	V <sub>IH2</sub>	2.7V ≤ DVCC ≤ 3.6V	0.7 DVCC		DVCC+0.3	
	Schmitt-Triggered port	V <sub>IH3</sub>		0.8 DVCC		CVCC+0.3	
	X1	V <sub>IH4</sub>	2.7V ≤ CVCC ≤ 3.6V	0.9 CVCC			
Low-level output voltage		V <sub>OL</sub>	I <sub>OL</sub> = 2mA DVCC ≥ 2.7V	-	-	0.4	V
High-level output voltage		V <sub>OH</sub>	I <sub>OH</sub> = -2mA DVCC ≥ 2.7V	2.4	-	-	V
Input leakage current	Except CEC	I <sub>LI1</sub>	0.0 ≤ V <sub>IN</sub> ≤ DVCC 0.0 ≤ V <sub>IN</sub> ≤ AVCC	-	0.02	± 5	μA
	CEC	I <sub>LI2</sub>	0.0 ≤ V <sub>IN</sub> ≤ 3.6				
Output leakage current	Except CEC	I <sub>LO1</sub>	0.2 ≤ V <sub>IN</sub> ≤ DVCC - 0.2 0.2 ≤ V <sub>IN</sub> ≤ AVCC - 0.2	-	0.05	± 10	
	CEC	I <sub>LO2</sub>	0.2 ≤ V <sub>IN</sub> ≤ 3.4				
Pull-up resistor at Reset		RRST	DVCC = 2.7V~3.6V	-	50	150	kΩ
Schmitt-Triggered port		V <sub>TH</sub>	2.7V ≤ DVCC ≤ 3.6V	0.3	0.6	-	V
Programmable pull-up/ pull-down resistor		PKH	DVCC = 2.7V~3.6V	-	50	150	kΩ
Pin capacitance (Except power supply pins)		C <sub>IO</sub>	fc = 1MHz	-	-	10	pF

(Note 1) Ta=25°C, DVCC = REGVCC = AVCC = 3.3V, unless otherwise noted.

(Note 2) The same voltage must be supplied to DVCC, AVCC, CVCC and REGVCC.

### 20.3 DC Electrical Characteristics (2/2)

(1) TMPM330

DVCC = AVCC = CVCC = REGVCC = 2.7V~3.6V, Ta = -40~85°C

Parameter	Symbol	Rating	Min.	Typ. (Note 1)	Max.	Unit
NORMAL (Note 2) Gear 1/1	I <sub>CC</sub>	f <sub>sys</sub> = 40 MHz ( f <sub>osc</sub> = 10 MHz )	-	32	42	mA
IDLE (Note 3)			-	8	13	
SLOW		f <sub>s</sub> = 32.768kHz	-	2.5	6	μA
SLEEP			-	55	500	
STOP			-	-	45	

(Note 1) Ta=25°C, DVCC = AVCC = CVCC = REGVCC = 3.3V, unless otherwise noted.

(Note 2) ICC NORMAL: Measured with the dhrystone ver. 2.1 operated in FLASH. All functions operats excluding A/D.

(Note 3) ICC IDLE: Measured with all functions stopped. The currents flow through DVCC, AVCC, CVCC15 and REGVCC are included.

## 20.4 10-bit ADC Electrical Characteristics

DVCC = AVCC = CVCC = REGVCC = VREFH = 2.7V~3.6V,

AVSS = DVSS, Ta = -40~85°C

AVCC load capacitance  $\geq 3.3\mu\text{F}$ , VREFH load capacitance  $\geq 3.3\mu\text{F}$

Parameter		Symbol	Rating	Min	Typ	Max	Unit
Analog reference voltage (+)		VREFH	-	2.7	3.3	3.6	V
Analog input voltage		VAIN	-	AVSS	-	VREFH	V
Analog supply current	A/D conversion	IREF	DVSS = AVSS	-	2.5	5.5	mA
	Non-A/D conversion			-	$\pm 0.02$	$\pm 5$	$\mu\text{A}$
Supply current	A/D conversion	-	Non-IREF	-	-	3	mA
INL error		-	AIN resistance $\leq 600\Omega$ AIN load capacitance $\leq 30\text{pF}$ Conversion time $\geq 1.15\mu\text{s}$	-	$\pm 2$	$\pm 3$	LSB
DNL error				-	$\pm 1$	$\pm 2$	
Offset error				-	$\pm 2$	$\pm 4$	
Full-scale error				-	$\pm 2$	$\pm 4$	
INL error		-	AIN resistance $\leq 600\Omega$ AIN load capacitance $\leq 0.1\mu\text{F}$ Conversion time $\geq 1.15\mu\text{s}$	-	$\pm 2$	$\pm 3$	
DNL error				-	$\pm 1$	$\pm 2$	
Offset error				-	$\pm 2$	$\pm 4$	
Full-scale error				-	$\pm 2$	$\pm 4$	
INL error		-	AIN resistance $\leq 10\text{k}\Omega$ AIN load capacitance $\geq 0.1\mu\text{F}$ Conversion time $\geq 2.30\mu\text{s}$	-	$\pm 2$	$\pm 3$	
DNL error				-	$\pm 1$	$\pm 2$	
Offset error				-	$\pm 2$	$\pm 4$	
Full-scale error				-	$\pm 2$	$\pm 4$	

(Note) 1LSB = (VREFH - AVSS) / 1024[V]

## 20.5 AC Electrical Characteristics

### 21.5.1 Serial Channel Timing (SIO)

#### (1) I/O Interface mode

In the table below, the letter x represents the SIO operation clock cycle time which is identical to the fsys cycle time. It varies depending on the programming of the clock gear function.

#### 1) SCLK input mode

[Input]

Parameter	Symbol	Equation		40 MHz		Unit
		Min	Max	Min	Max	
SCLK Clock High width (input)	$t_{SCH}$	4x	-	100	-	ns
SCLK Clock Low width (input)	$t_{SCL}$	4x	-	100	-	
SCLK cycle	$t_{SCY}$	$t_{SCH} + t_{SCL}$	-	200	-	
RxD valid to SCLK rise or fall (Note 1)	$t_{SRD}$	30	-	30	-	
RxD hold or fall after SCLK rising (Note 1)	$t_{HSR}$	x + 30	-	55	-	

[Output]

Parameter	Symbol	Equation		40 MHz		Unit
		Min	Max	Min	Max	
SCLK Clock High width (input)	$t_{SCH}$	4x	-	120 (Note 3)	-	ns
SCLK Clock Low width (input)	$t_{SCL}$	4x	-	120 (note 3)	-	
SCLK cycle	$t_{SCY}$	$t_{SCH} + t_{SCL}$	-	240	-	
TxD to SCLK rise or fall (Note 1)	$t_{OSS}$	$t_{SCY} / 2 - 3x - 45$	-	0 (Note 2)	-	
TxD hold or fall after SCLK rising (Note 1)	$t_{OHS}$	$t_{SCY} / 2$	-	75	-	

**(Note 1) SCLK rise or fall: Measured relative to the programmed active edge of SCLK.**

**(Note 2) Use the frequency of SCLK in a range where the calculation value keeps positive.**

**(Note 3) The value indicates a minimum value that enables tOSS to be zero or more.**

2) SCLK output mode

Parameter	Symbol	Equation		40 MHz		Unit
		Min	Max	Min	Max	
SCLK cycle (programmable)	$t_{SCY}$	4x	-	100	-	ns
TxD to SCLK rise	$t_{OSS}$	$t_{scv} / 2 - 20$	-	30	-	
TxD hold after SCLK rising	$t_{OHS}$	$t_{scv} / 2 - 20$	-	30	-	
RxD valid to SCLK rise	$t_{SRD}$	45	-	45	-	
RxD hold after SCLK rising	$t_{HSR}$	0	-	0	-	

AC measurement condition

/Output levels: High 0.8DVCC3 V/Low 0.2DVCC3V, CL=30 pF

/Input levels: Refer to low-level input voltage and high-level input voltage in 21.2 DC Electrical Characteristics.

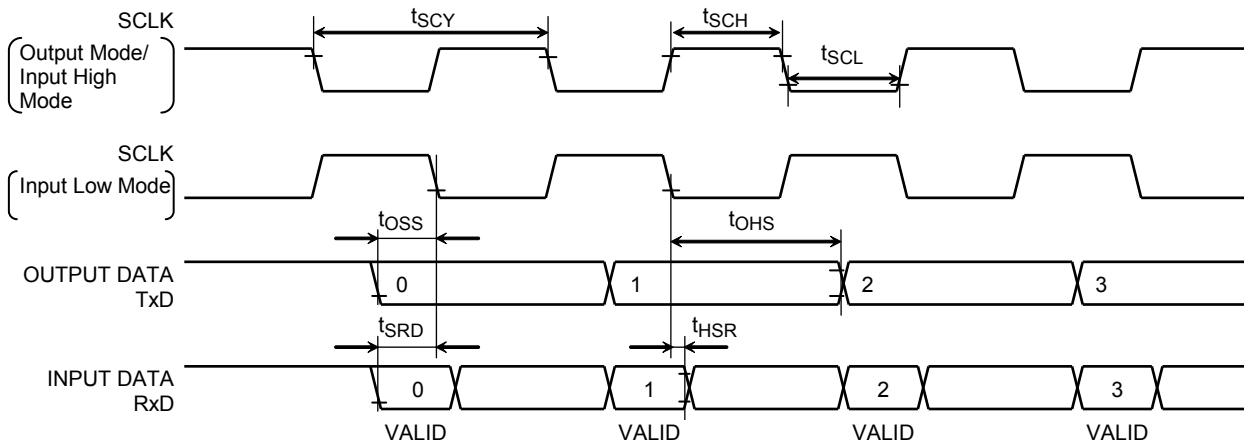

### 21.5.2 SBI (I2C)

#### (1) I2C Mode

In the table below, the letter x represents the I2C operation clock cycle time which is identical to the fsys cycle time. It varies depending on the programming of the clock gear function.

n denotes the value of n programmed into the SCK (SCL output frequency select) field in the SBInCR.

Parameter	Symbol	Equation		Standard Mode		Fast Mode		Unit
		Min	Max	Min	Max	Min	Max	
SCL clock frequency	t <sub>SCL</sub>	0	-	0	100	0	400	kHz
Hold time for START condition	t <sub>HD;STA</sub>	-	-	4.0	-	0.6	-	μs
SCL low width (Input) (Note 1)	t <sub>LOW</sub>	-	-	4.7	-	1.3	-	μs
SCL high width (Input) (Note 2)	t <sub>HIGH</sub>	-	-	4.0	-	0.6	-	μs
Setup time for a repeated START condition	t <sub>SU;STA</sub>	(Note 5)	-	4.7	-	0.6	-	μs
Data hold time (Input) (Note 3, 4)	t <sub>HD;DAT</sub>	-	-	0.0	-	0.0	-	μs
Data setup time	t <sub>SU;DAT</sub>	-	-	250	-	100	-	ns
Setup time for a stop condition	t <sub>SU;STO</sub>	-	-	4.0	-	0.6	-	μs
Bus free time between stop condition and start condition	t <sub>BUF</sub>	(Note 5)	-	4.7	-	1.3	-	μs

AC measurement condition

/Output levels: High 0.8DVCC3 V/Low 0.2DVCC3V, CL=30 pF

/Input levels: Refer to low-level input voltage and high-level input voltage in 21.2 DC Electrical Characteristics.

**(Note 1) SCL clock low width (output) is calculated with:  $(2^{n-1} + 58)/x$**

**(Note 2) SCL clock high width (output) is calculated with:  $(2^{n-1} + 14)/x$**

**Notice: On I2C-bus specification, Maximum Speed of Standard Mode is 100KHz, Fast mode is 400Khz. Internal SCL Frequency setting should comply with Note1 & Note2 shown above.**

**(Note 3) The output data hold time is equal to 4x of internal SCL.**

**(Note 4) The Philips I2C-bus specification states that a device must internally provide a hold time of at least 300 ns for the SDA signal to bridge the undefined region of the falling edge of SCL. However, this SBI does not satisfy this requirement. Also, the output buffer for SCL does not incorporate slope control of the falling edges; therefore, the equipment manufacturer should design so that the input data hold time shown in the table is satisfied, including tr/tf of the SCL and SDA lines.**

**(Note 5) Software-dependent.**

**(Note 6) The Philips I2C-bus specification instructs that if the power supply to a Fast-mode device is switched off, the SDA and SCL I/O pins must be floating so that they don't obstruct the bus lines. However, this SBI does not satisfy this requirement.**

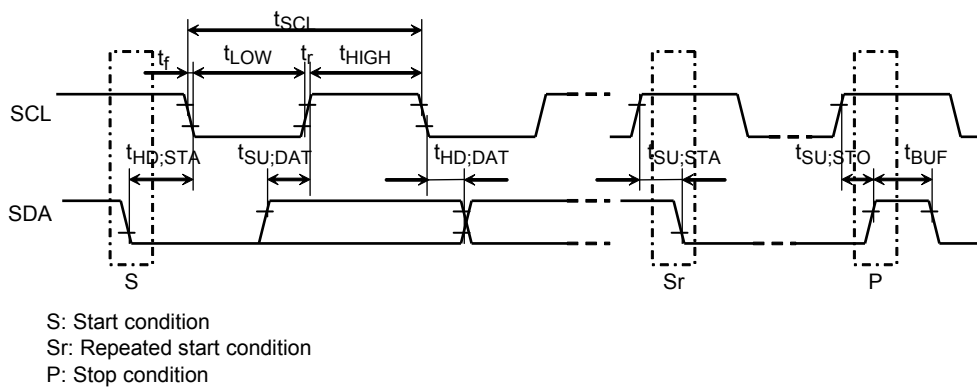

## (2) Clock-Synchronous 8-Bit SIO mode

In the table below, the letter x represents the I2C operation clock cycle time which is identical to the fsys cycle time. It varies depending on the programming of the clock gear function.

The electrical specifications below are for an SCK signal with a 50% duty cycle.

## 1) SCK Input Mode

## [INPUT]

Parameter	Symbol	Equation		40MHz		Unit
		Min	Max	Min	Max	
SCK Clock High width (input)	t <sub>SCH</sub>	4x	-	100	-	ns
SCK Clock Low width (input)	t <sub>SCL</sub>	4x	-	100	-	
SCK cycle	t <sub>SCY</sub>	t <sub>SCH</sub> + t <sub>SCL</sub>	-	200	-	
RxD valid to SCK rise	t <sub>SRD</sub>	30 - x	-	5	-	
RxD hold after SCK rising	t <sub>HSR</sub>	2x+30	-	80	-	

## [OUTPUT]

Parameter	Symbol	Equation		40MHz		Unit
		Min	Max	Min	Max	
SCK Clock High width (input)	t <sub>SCH</sub>	4x	-	100	-	ns
SCK Clock Low width (input)	t <sub>SCL</sub>	4x	-	100	-	
SCK cycle	t <sub>SCY</sub>	t <sub>SCH</sub> + t <sub>SCL</sub>	-	200	-	
TxD to SCK rise	t <sub>OSS</sub>	t <sub>SCY</sub> /2 - 3x - 45	-	0 (Note1)	-	
TxD hold after SCK rising	t <sub>OHS</sub>	t <sub>SCY</sub> /2 + x	-	125	-	

## AC measurement condition

/Output levels: High 0.8DVCC3 V/Low 0.2DVCC3V, CL=30 pF

/Input levels: Refer to low-level input voltage and high-level input voltage in 21.2 DC Electrical Characteristics.

**(Note1)** Use the frequency of SCLK in a range where the calculation value keeps positive.

**(Note2)** The value indicates a minimum value that enables t<sub>OSS</sub> to be zero or more.

2) SCK Output Mode

Parameter	Symbol	Equation		40MHz		Unit
		Min	Max	Min	Max	
SCK cycle (programmable)	$t_{SCY}$	16x (Note1)	-	400	-	ns
TxD to SCK rise	$t_{OSS}$	$t_{SCY}/2 - 20$ (Note2)	-	180	-	
TxD hold after SCK rising	$t_{OHS}$	$t_{SCY}/2 - 20$	-	180	-	
RxD valid to SCK rise	$t_{SRD}$	x+45	-	70	-	
RxD data hold after SCK rising	$t_{HSR}$	0	-	0	-	

AC measurement condition

/Output levels: High 0.8DVCC3 V/Low 0.2DVCC3V, CL=30 pF

/Input levels: Refer to low-level input voltage and high-level input voltage in 21.2 DC Electrical Characteristics.

**(Note1) SCK cycle after automatic wait becomes 14x.**

**(Note2)  $t_{OSS}$  after automatic wait may be  $t_{SCY}/2-x-20$ .**

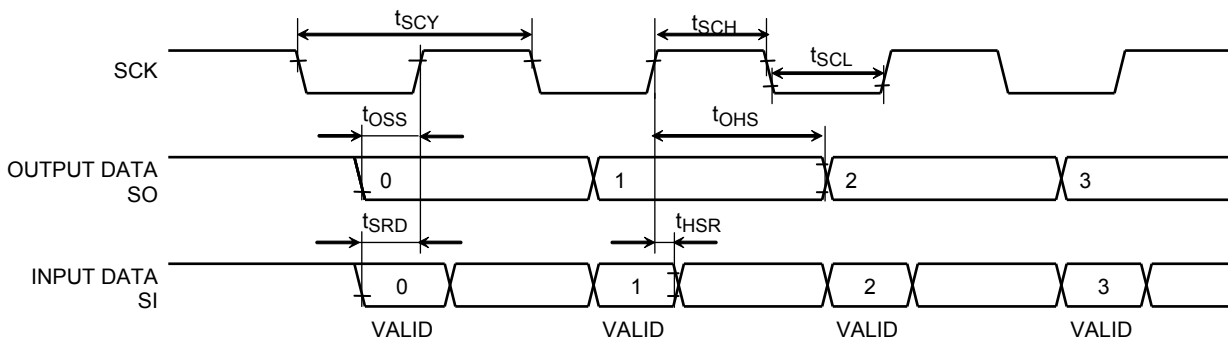

### 21.5.3 Event Counter

In the table below, the letter x represents the TMRB operation clock cycle time which is identical to the fsys cycle time. It varies depending on the programming of the clock gear function.

Parameter	Symbol	Equation		40MHz		Unit
		Min	Max	Min	Max	
Clock low pulse width	t <sub>VCKL</sub>	2x + 100	-	150	-	ns
Clock high pulse width	t <sub>VCKH</sub>	2x + 100	-	150	-	ns

AC measurement condition

/Output levels: High 0.8DVCC3 V/Low 0.2DVCC3V, CL=30 pF

/Input levels: Refer to low-level input voltage and high-level input voltage in 21.2 DC Electrical Characteristics.

### 21.5.4 Capture

In the table below, the letter x represents the TMRB operation clock cycle time which is identical to the fsys cycle time. It varies depending on the programming of the clock gear function.

Parameter	Symbol	Equation		40MHz		Unit
		Min	Max	Min	Max	
Low pulse width	t <sub>CPL</sub>	2x + 100	-	150	-	ns
High pulse width	t <sub>CPH</sub>	2x + 100	-	150	-	ns

AC measurement condition

/Output levels: High 0.8DVCC3 V/Low 0.2DVCC3V, CL=30 pF

/Input levels: Refer to low-level input voltage and high-level input voltage in 21.2 DC Electrical Characteristics.

### 21.5.5 External Interrupts

In the table below, the letter x represents the fsys cycle time.

- except STOP release interrupts

Parameter	Symbol	Equation		40MHz		Unit
		Min	Max	Min	Max	
Low pulse width for INT0~7	t <sub>INTAL</sub>	x + 100	-	125	-	ns
High pulse width for INT0~7	t <sub>INTAH</sub>	x + 100	-	125	-	ns

- STOP release interrupts

Parameter	Symbol	Min	Max	Unit
Low pulse width for INT0~7	t <sub>INTBL</sub>	100	-	ns
High pulse width for INT0~7	t <sub>INTBL</sub>	100	-	ns

AC measurement condition

/Output levels: High 0.8DVCC3 V/Low 0.2DVCC3V, CL=30 pF

/Input levels: Refer to low-level input voltage and high-level input voltage in 21.2 DC Electrical Characteristics.

21.5.6  $\overline{\text{NMI}}$

Parameter	Symbol	Min	Max	Unit
Low pulse width for $\overline{\text{NMI}}$	$t_{\text{INTCL}}$	100	-	ns

AC measurement condition

/Output levels: High 0.8DVCC3 V/Low 0.2DVCC3V, CL=30 pF

/Input levels: Refer to low-level input voltage and high-level input voltage in 21.2 DC Electrical Characteristics.

21.5.7 SCOUT Pin AC Characteristic

Parameter	Symbol	Equation		40MHz		Unit
		Min	Max	Min	Max	
High pulse width	$t_{\text{SCH}}$	0.5T - 5		7.5		ns
Low pulse width	$t_{\text{SCL}}$	0.5T - 5		7.5		ns

AC measurement condition

/Output levels: High 0.8DVCC3 V/Low 0.2DVCC3V, CL=30 pF

/Input levels: Refer to low-level input voltage and high-level input voltage in 21.2 DC Electrical Characteristics.

(Note) In the above table, the letter T represents the cycle time of the SCOUT output clock.

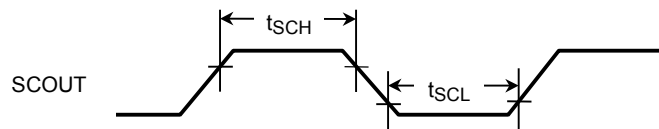

### 21.5.8 Debug Communication

(1) SWD Interface

Parameter	Symbol	Min	Max	Unit
CLK cycle	$T_{dck}$	83.33	-	ns
DATA to CLK rising	$T_{dos}$	12	-	ns
DATA hold after CLK rising	$T_{doh}$	4	-	ns
DATA hold after CLK falling	$T_{dih}$	-	6	ns

AC measurement condition

/Output levels: High 0.8DVCC3 V/Low 0.2DVCC3V, CL=30 pF

/Input levels: Refer to low-level input voltage and high-level input voltage in 21.2 DC Electrical Characteristics.

(2) JTAG Interface

Parameter	Symbol	Min	Max	Unit
CLK cycle	$T_{dck}$	100	-	ns
DATA to CLK rising	$T_{dos}$	3	-	ns
DATA hold after CLK rising	$T_{doh}$	25	-	ns
DATA hold after CLK falling	$T_{dih}$	-	15	ns

AC measurement condition

/Output levels: High 0.8DVCC3 V/Low 0.2DVCC3V, CL=30 pF

/Input levels: Refer to low-level input voltage and high-level input voltage in 21.2 DC Electrical Characteristics.

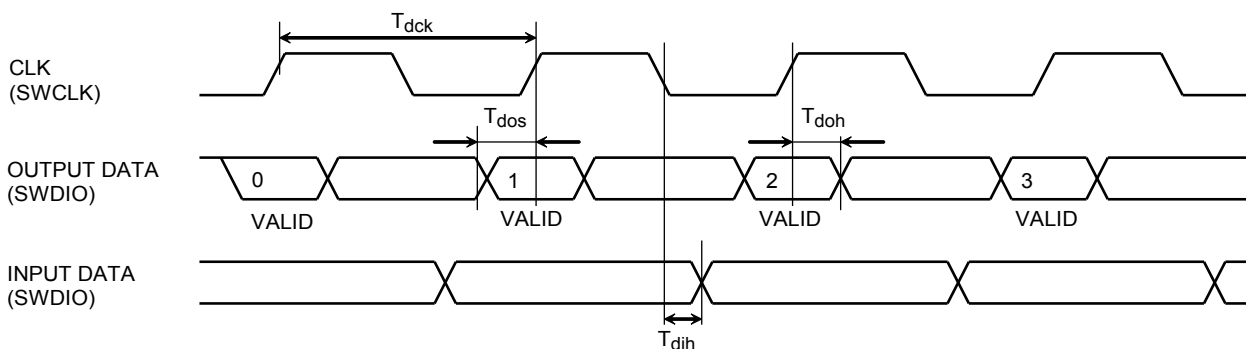

21.5.9 TRACE Output

Parameter	Symbol	Min	Max	Unit
TRACECLK cycle	$T_{dclk}$	50	-	ns
TRACEDATA valid to DCLK rise	$t_{setupr}$	2	-	ns
TRACEDATA hold after DCLK rising	$t_{holdr}$	1	-	ns
TRACEDATA valid to DCLK fall	$t_{setupf}$	2	-	ns
TRACEDATA hold after DCLK falling	$t_{holdf}$	1	-	ns

AC measurement condition

/Output levels: High 0.8DVCC3 V/Low 0.2DVCC3V, CL=30 pF

/Input levels: Refer to low-level input voltage and high-level input voltage in 21.2 DC Electrical Characteristics.

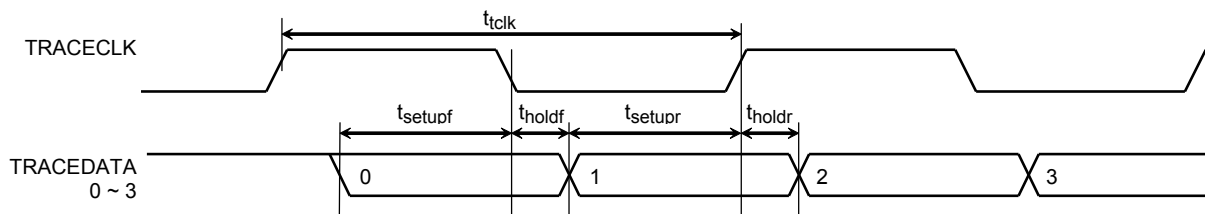

## 20.6 Oscillation Circuit

The TMPM330 has been evaluated by the oscillator vendor below. Use this information when selecting external parts.

**(Note)**The load value of the oscillator is the sum of loads (C1 and C2) and the floating load of the actual assembled board. There is a possibility of operating error when using C1 and C2 values in the table below. When designing the board, design the minimum length pattern around the oscillator. We also recommend that oscillator evaluation be carried out using the actual board.

### (1) Connection example

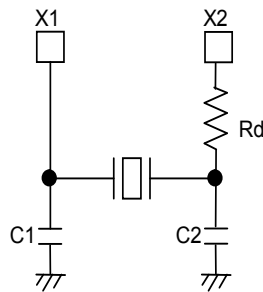

Fig. 21-1 High-frequency oscillation connection

### (2) Recommended ceramic oscillator

The TMPM330 recommends the high-frequency oscillator by Murata Manufacturing Co., Ltd.  
Please refer to the following URL for details.  
<http://www.murata.co.jp>

### (3) Recommended ceramic oscillator

The TMPM330 recommends the high-frequency oscillator by KYOCERA Crystal Device Corporation.  
Please refer to the following URL for details.  
<http://www.kinseki.co.jp>

## 20.7 Handling Precaution

### 21.7.1 Notice of Power supply

#### 21.7.1.1 Notice if Power-on

The power supply must be raised (from 0V to 2.7V) at a speed of 0.37ms/V or slower.

The power-on sequence must include the time for the internal regulator and oscillator to be stable. In the TMPM330, the internal regulator requires at least 700  $\mu$ s to be stable. The time required to achieve stable oscillation varies with system. At cold reset, the external reset pin must be kept low for a duration of time sufficiently long enough for the internal regulator and oscillator to be stable.

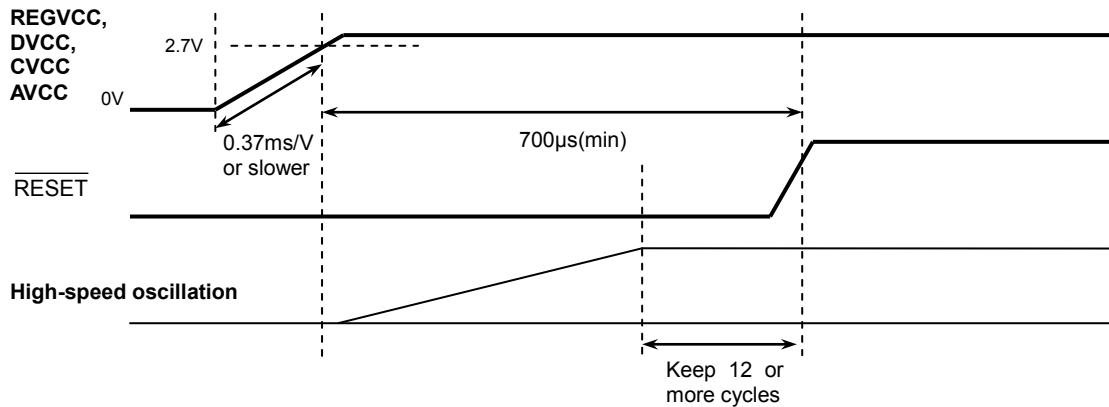

#### 21.7.1.2 Notice of Power on again

When power on again after power off, the voltage of power supply is equal or less than 0.5V and keeps this level until more than 2ms.

After this, the power supply must be raised at a speed of 0.1ms/V or slower.

Regarding to reset, refer to 21.7.1.1.

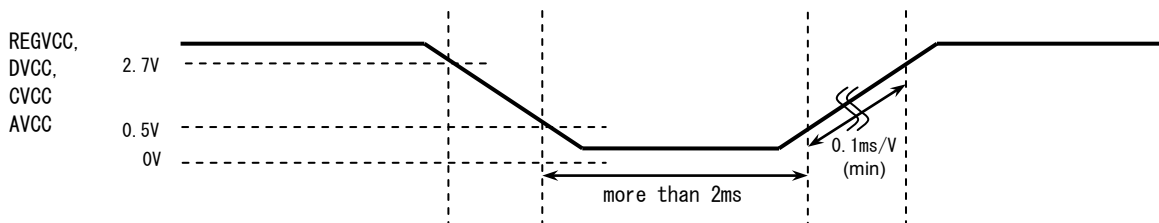

## 21 Port Section Equivalent Circuit Schematic

- Reading the schematics

Basically, the gate symbols written are the same as those used for the standard CMOS logic IC [74HCXX] series.

The input protection resistance ranges from several tens of ohms to several hundreds of ohms. Damping resistors X2 and XT2 are shown with a typical value.

- PA0, PB1-2, PE1-3, PE5-6, PF1-7, PG0-6, PH0-7, PI6-7, PJ0-3, PJ6-7

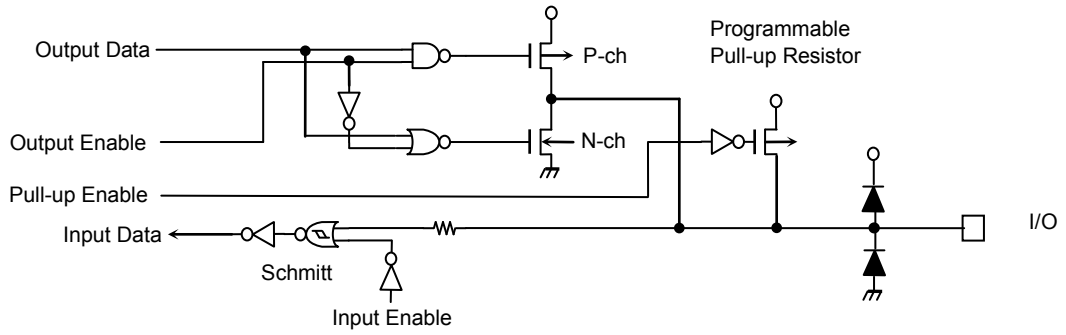

- PA1

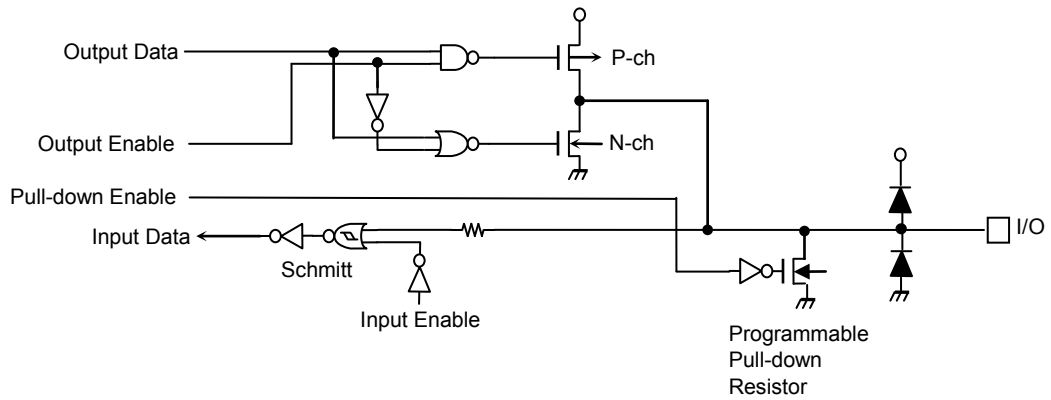

- PA2-7, PB0, PB3-7, PE0, PE4, PF0, PG7, PI0-5, PJ4-5, PK1-2

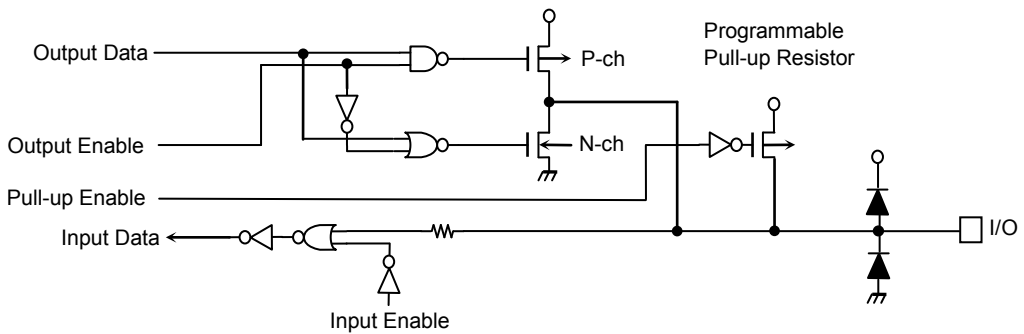

- PC0-3, PD4-7

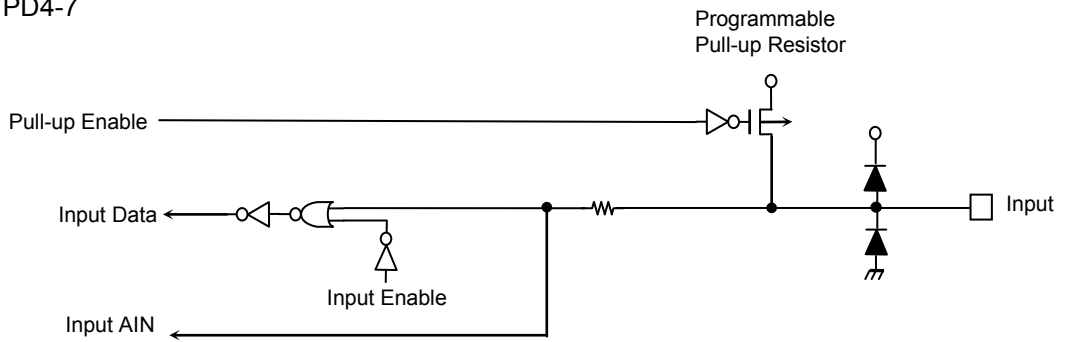

- PD0-3

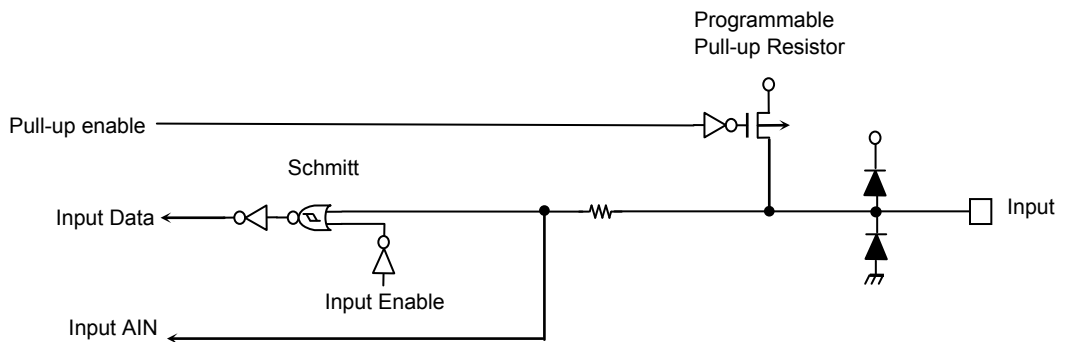

- PK0

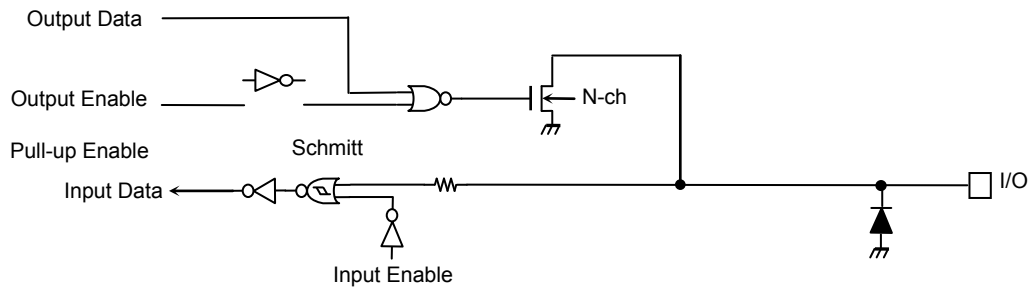

- $\overline{\text{NMI}}$ , MODE

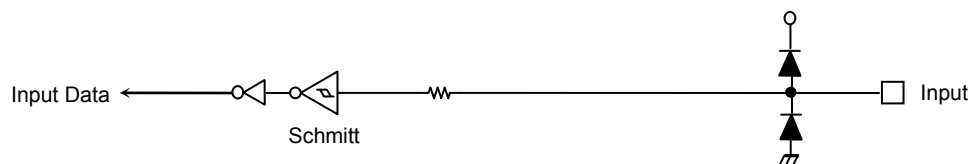

- $\overline{\text{RESET}}$

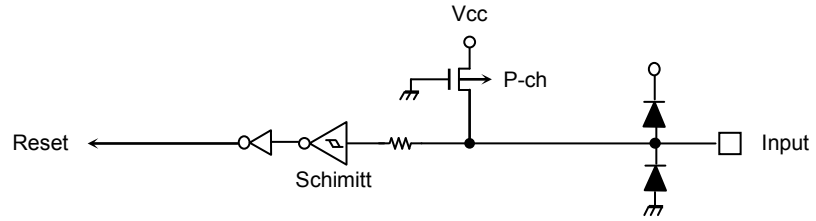

- X1, X2

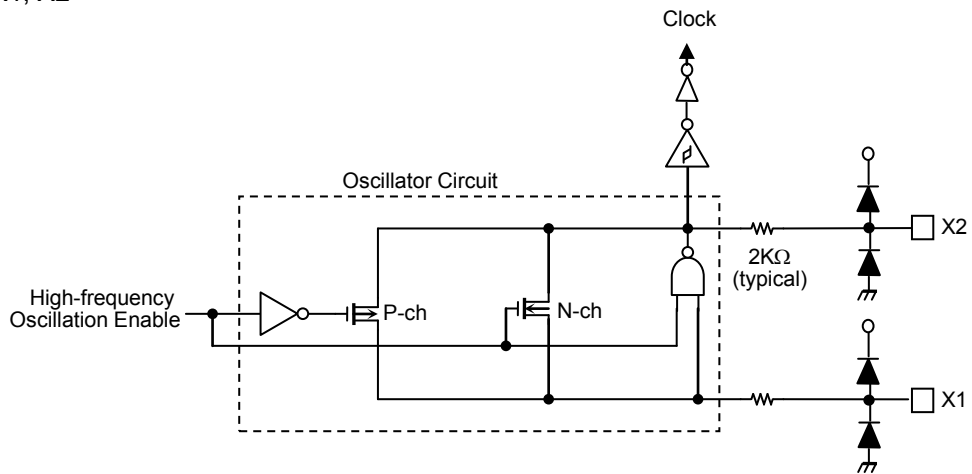

- XT1, XT2

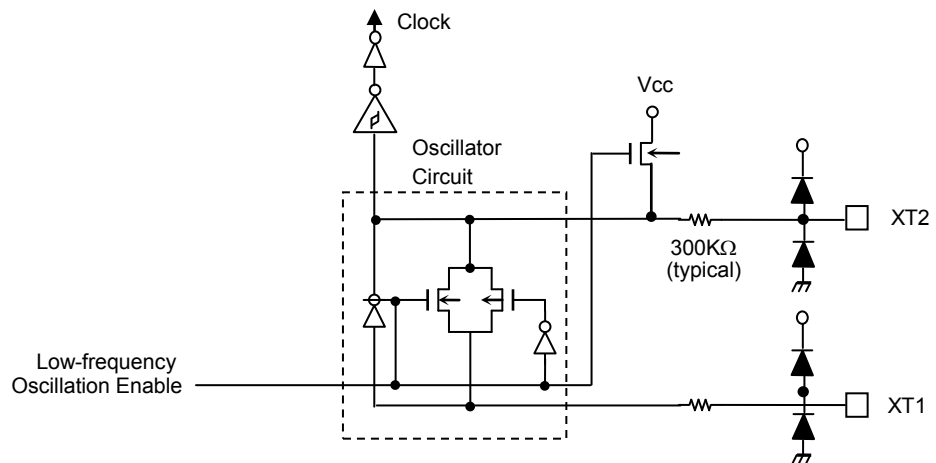

- VREFH, AVSS

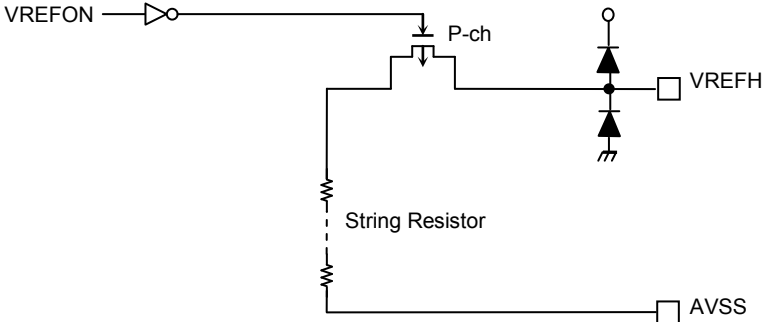



Pin detail

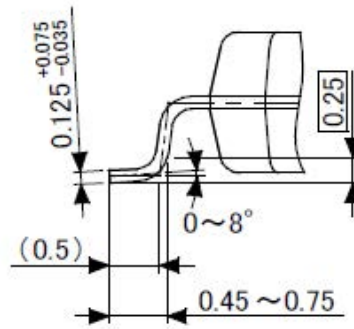

## RESTRICTIONS ON PRODUCT USE

- Toshiba Corporation, and its subsidiaries and affiliates (collectively "TOSHIBA"), reserve the right to make changes to the information in this document, and related hardware, software and systems (collectively "Product") without notice.
- This document and any information herein may not be reproduced without prior written permission from TOSHIBA. Even with TOSHIBA's written permission, reproduction is permissible only if reproduction is without alteration/omission.
- Though TOSHIBA works continually to improve Product's quality and reliability, Product can malfunction or fail. Customers are responsible for complying with safety standards and for providing adequate designs and safeguards for their hardware, software and systems which minimize risk and avoid situations in which a malfunction or failure of Product could cause loss of human life, bodily injury or damage to property, including data loss or corruption. Before customers use the Product, create designs including the Product, or incorporate the Product into their own applications, customers must also refer to and comply with (a) the latest versions of all relevant TOSHIBA information, including without limitation, this document, the specifications, the data sheets and application notes for Product and the precautions and conditions set forth in the "TOSHIBA Semiconductor Reliability Handbook" and (b) the instructions for the application with which the Product will be used with or for. Customers are solely responsible for all aspects of their own product design or applications, including but not limited to (a) determining the appropriateness of the use of this Product in such design or applications; (b) evaluating and determining the applicability of any information contained in this document, or in charts, diagrams, programs, algorithms, sample application circuits, or any other referenced documents; and (c) validating all operating parameters for such designs and applications. **TOSHIBA ASSUMES NO LIABILITY FOR CUSTOMERS' PRODUCT DESIGN OR APPLICATIONS.**
- **PRODUCT IS NEITHER INTENDED NOR WARRANTED FOR USE IN EQUIPMENTS OR SYSTEMS THAT REQUIRE EXTRAORDINARILY HIGH LEVELS OF QUALITY AND/OR RELIABILITY, AND/OR A MALFUNCTION OR FAILURE OF WHICH MAY CAUSE LOSS OF HUMAN LIFE, BODILY INJURY, SERIOUS PROPERTY DAMAGE AND/OR SERIOUS PUBLIC IMPACT ("UNINTENDED USE").** Except for specific applications as expressly stated in this document, Unintended Use includes, without limitation, equipment used in nuclear facilities, equipment used in the aerospace industry, Class 3 medical devices, equipment used for automobiles, and military vehicles and munitions. **IF YOU USE PRODUCT FOR UNINTENDED USE, TOSHIBA ASSUMES NO LIABILITY FOR PRODUCT.** For details, please contact your TOSHIBA sales representative or contact us via our website.
- Do not disassemble, analyze, reverse-engineer, alter, modify, translate or copy Product, whether in whole or in part.
- Product shall not be used for or incorporated into any products or systems whose manufacture, use, or sale is prohibited under any applicable laws or regulations.
- The information contained herein is presented only as guidance for Product use. No responsibility is assumed by TOSHIBA for any infringement of patents or any other intellectual property rights of third parties that may result from the use of Product. No license to any intellectual property right is granted by this document, whether express or implied, by estoppel or otherwise.
- **ABSENT A WRITTEN SIGNED AGREEMENT, EXCEPT AS PROVIDED IN THE RELEVANT TERMS AND CONDITIONS OF SALE FOR PRODUCT, AND TO THE MAXIMUM EXTENT ALLOWABLE BY LAW, TOSHIBA (1) ASSUMES NO LIABILITY WHATSOEVER, INCLUDING WITHOUT LIMITATION, INDIRECT, CONSEQUENTIAL, SPECIAL, OR INCIDENTAL DAMAGES OR LOSS, INCLUDING WITHOUT LIMITATION, LOSS OF PROFITS, LOSS OF OPPORTUNITIES, BUSINESS INTERRUPTION AND LOSS OF DATA, AND (2) DISCLAIMS ANY AND ALL EXPRESS OR IMPLIED WARRANTIES AND CONDITIONS RELATED TO SALE, USE OF PRODUCT, OR INFORMATION, INCLUDING WARRANTIES OR CONDITIONS OF MERCHANTABILITY, FITNESS FOR A PARTICULAR PURPOSE, ACCURACY OF INFORMATION, OR NONINFRINGEMENT.**
- Do not use or otherwise make available Product or related software or technology for any military purposes, including without limitation, for the design, development, use, stockpiling or manufacturing of nuclear, chemical, or biological weapons or missile technology products (mass destruction weapons). Product and related software and technology may be controlled under the applicable export laws and regulations including, without limitation, the Japanese Foreign Exchange and Foreign Trade Law and the U.S. Export Administration Regulations. Export and re-export of Product or related software or technology are strictly prohibited except in compliance with all applicable export laws and regulations.
- Please contact your TOSHIBA sales representative for details as to environmental matters such as the RoHS compatibility of Product. Please use Product in compliance with all applicable laws and regulations that regulate the inclusion or use of controlled substances, including without limitation, the EU RoHS Directive. **TOSHIBA ASSUMES NO LIABILITY FOR DAMAGES OR LOSSES OCCURRING AS A RESULT OF NONCOMPLIANCE WITH APPLICABLE LAWS AND REGULATIONS.**