

TOSHIBA BiCD Integrated Circuit Silicon Monolithic

# TB67S213FTAG

## PWM method PHASE-IN Bipolar stepping motor driver

The TB67S213FTAG is a pwm method phase signal controlled motor driver for two-phase bipolar stepping motor.

Using the BiCD process, the TB67S213FTAG is rated at 40V/2.5A.(Absolute maximum ratings)

Also, with the built-in VCC regulator, the TB67S213FTAG can be operated with a single motor power(VM) supply.

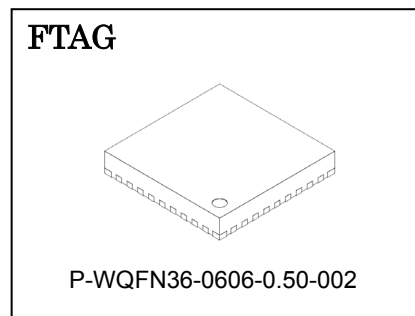

Weight:0.14(g)

## Features

- The TB67S213FTAG can operate a single bipolar stepping motor.
- PWM method current feedback control.
- Operational in Full, Half, and Quarter step resolutions.
- Uses low on-resistance MOSFETs for output stage.
- High voltage and large current. (For specification, please refer to the absolute maximum ratings and operation ranges.)
- Error detection circuits (Thermal Shutdown(TSD), Over current shutdown(ISD), and Power-on reset(POR))
- The built-in VCC regulator allows the TB67S213FTAG to operate with a single VM power supply.
- Customizable PWM chopping frequency using the external components (resistance/condenser).
- Package:

TB67S213FTAG: P-WQFN36-0606-0.50-002

Note) Please be careful about thermal conditions during use.

## Pin assignment

(Top View)

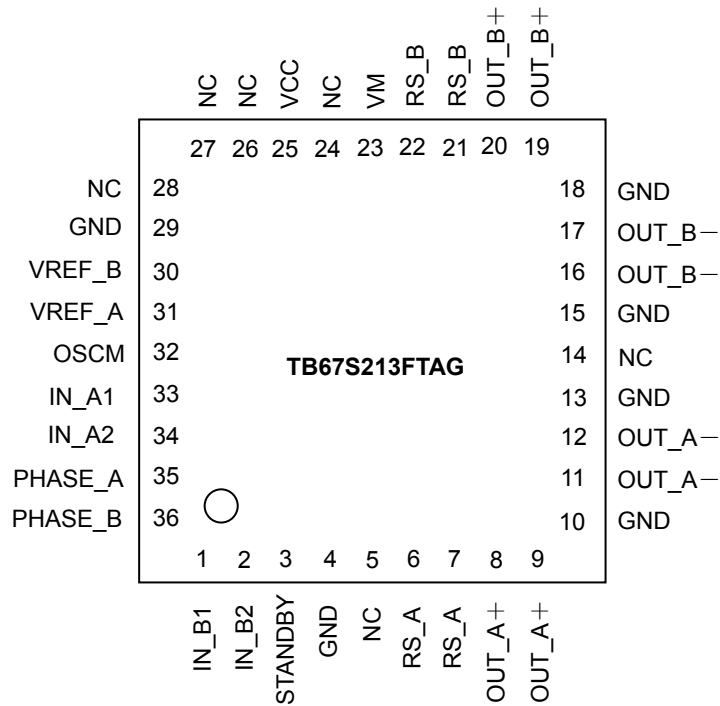

\* Please make sure to short the corner pads and the backside exposed pad to the ground pattern of the board.

## Block Diagram

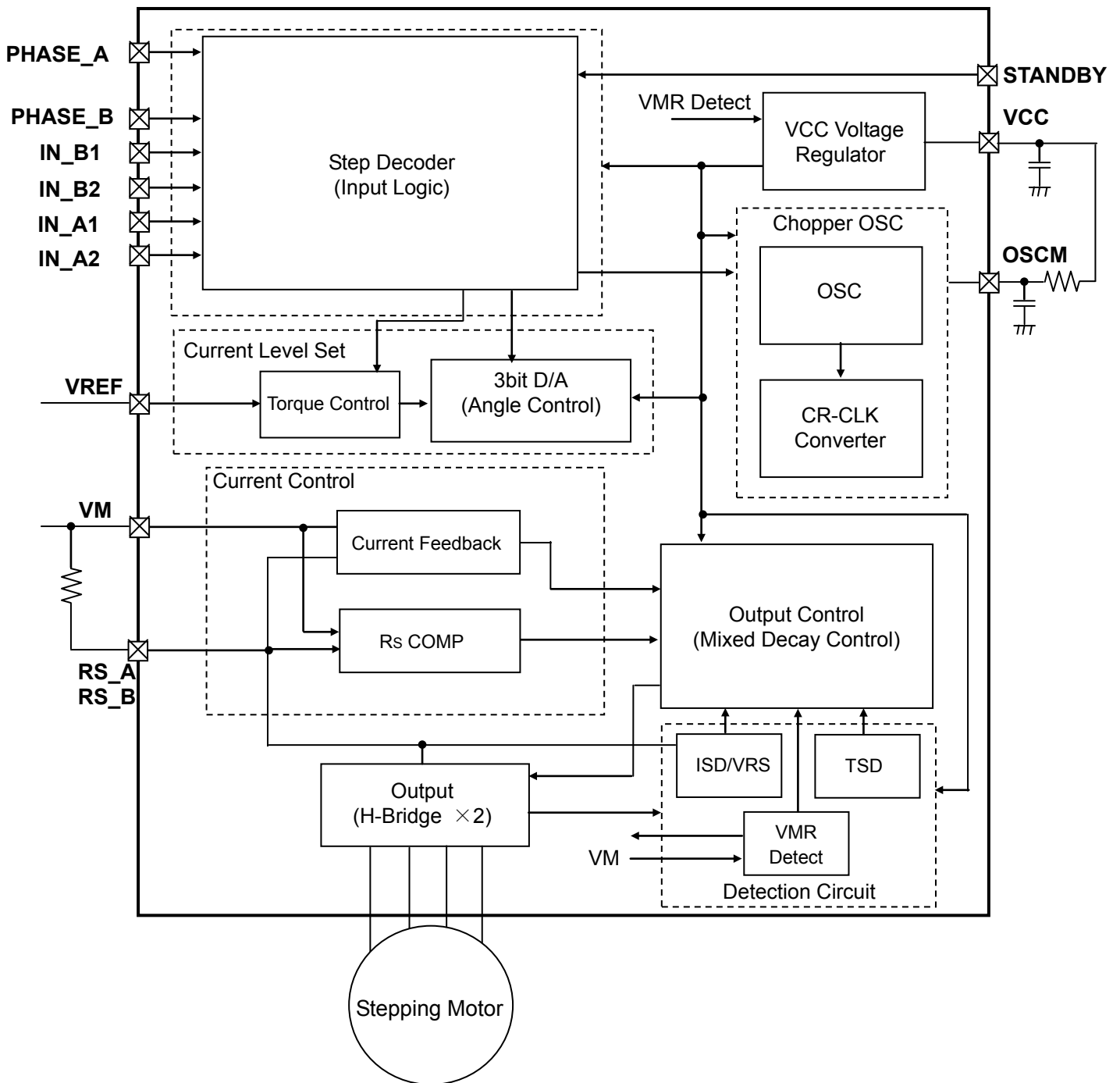

\* Please note that in the block diagram, functional blocks or constants may be omitted or simplified for explanatory purposes.

\* Please make sure that all GND pins are shorted to the board's ground pattern with a single point. Also, make sure to take extra care with pattern layout, due to heat generation.

Please take extra care while tracing the layout of the VM, GND and output patterns to avoid shortage across output, GND or power supplies. If such shortage occurs, the TB67S213 may be permanently damaged.

The utmost care should also be taken for pattern designing and implementation of the TB67S213. If power-relevant pins such as VM, RS, OUT, and GND (which is capable of running particularly large current) are wired incorrectly, an operation error may occur or the TB67S213 may be destroyed. The logic input pins must also be wired correctly. Otherwise, the TB67S213 may be damaged by a current larger than the specified current running through the IC.

## Pin assignment / function

### TB67S213FTAG (QFN36)

Pin No.1 – 36

Pin No.	Pin Name	Function
1	IN_B1	Bch step resolution control 1
2	IN_B2	Bch step resolution control 2
3	STANDBY	Standby set pin
4	GND	Ground pin
5	NC	Non-connection pin
6	RS_A	Motor Ach current sense pin
7	RS_A	Motor Ach current sense pin
8	OUT_A+	Motor Ach (+) output pin
9	OUT_A+	Motor Ach (+) output pin
10	GND	Ground pin
11	OUT_A-	Motor Ach (-) output pin
12	OUT_A-	Motor Ach (-) output pin
13	GND	Ground pin
14	NC	Non-connection pin
15	GND	Ground pin
16	OUT_B-	Motor Bch (-) output pin
17	OUT_B-	Motor Bch (-) output pin
18	GND	Ground pin
19	OUT_B+	Motor Bch (+) output pin
20	OUT_B+	Motor Bch (+) output pin
21	RS_B	Motor Bch current sense pin
22	RS_B	Motor Bch current sense pin
23	VM	VM power supply pin
24	NC	Non-connection pin
25	VCC	Internal VCC regulator monitor pin
26	NC	Non-connection pin
27	NC	Non-connection pin
28	NC	Non-connection pin
29	GND	Ground pin
30	VREF_B	Motor Bch current threshold set pin
31	VREF_A	Motor Ach current threshold set pin
32	OSCM	Internal Oscillator frequency set pin
33	IN_A1	Ach step resolution control 1
34	IN_A2	Ach step resolution control 2
35	PHASE_A	Ach phase set pin
36	PHASE_B	Bch phase set pin

•Please do not run patterns under NC pins.

•Please short the pins with the same pin names, while using the TB67S213.

## Equivalent circuit

### TB67S213FTAG(QFN36)

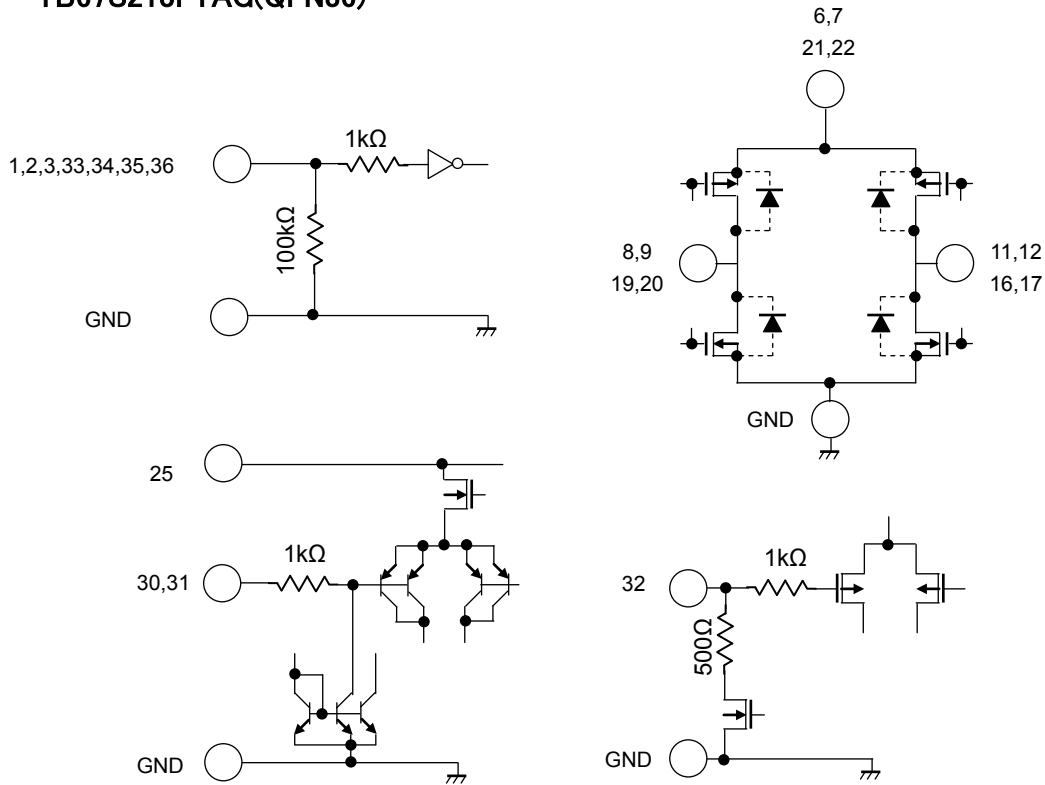

The equivalent circuit diagrams may be simplified or some parts of them may be omitted for explanatory purposes.

Pin No	Pin name
1	IN_B1
2	IN_B2
3	STANDBY
6,7	RS_A
8,9	OUT_A+
11,12	OUT_A-
16,17	OUT_B-
19,20	OUT_B+
21,22	RS_B
23	VM
25	VCC
30	VREF_B
31	VREF_A
32	OSCM
33	IN_A1
34	IN_A2
35	PHASE_A
36	PHASE_B

## Function explanation(Stepping motor control)

Note: The current is defined “+(plus)” when the motor current flows from OUT\_X+ → OUT\_X-. Also, the current is defined “-(minus)” when the motor current flows from OUT\_X- → OUT\_X+.

### <Full step resolution>

Phase A				Phase B			
Input			Output	Input			Output
PHASE_A	IN_A1	IN_A2	IOUT(A)	PHASE_B	IN_B1	IN_B2	IOUT(B)
H	H	H	100%	H	H	H	100%
L	H	H	-100%	H	H	H	100%
L	H	H	-100%	L	H	H	-100%
H	H	H	100%	L	H	H	-100%

IN\_A1,IN\_A2,IN\_B1,IN\_B2 is recommended to set to “Low” level during power-on sequence.

### <Half step resolution>

Phase A				Phase B			
Input			Output	Input			Output
PHASE_A	IN_A1	IN_A2	IOUT(A)	PHASE_B	IN_B1	IN_B2	IOUT(B)
H	H	H	100%	H	H	H	100%
X	L	L	0%	H	H	H	100%
L	H	H	-100%	H	H	H	100%
L	H	H	-100%	X	L	L	0%
L	H	H	-100%	L	H	H	-100%
X	L	L	0%	L	H	H	-100%
H	H	H	100%	L	H	H	-100%
H	H	H	100%	X	L	L	0%

X: Don't care

## <Quarter step resolution>

Phase A				Phase B			
Input			Output	Input			Output
PHASE_A	IN_A1	IN_A2	IOUT(A)	PHASE_B	IN_B1	IN_B2	IOUT(B)
H	H	L	71%	H	H	L	71%
H	L	H	38%	H	H	H	100%
X	L	L	0%	H	H	H	100%
L	L	H	-38%	H	H	H	100%
L	H	L	-71%	H	H	L	71%
L	H	H	-100%	H	L	H	38%
L	H	H	-100%	X	L	L	0%
L	H	H	-100%	L	L	H	-38%
L	H	L	-71%	L	H	L	-71%
L	L	H	-38%	L	H	H	-100%
X	L	L	0%	L	H	H	-100%
H	L	H	38%	L	H	H	-100%
H	H	L	71%	L	H	L	-71%
H	H	H	100%	L	L	H	-38%
H	H	H	100%	X	L	L	0%
H	H	H	100%	H	L	H	38%

X: Don't care

## Other functions

Pin Name	H	L	Notes
PHASE_X	OUT_X+ :H OUT_X- :L	OUT_X+ :L OUT_X- :H	When set to "H", the motor current is set to flow from OUT_X+ -> OUT_X-.
STANDBY	Motor function ready	Standby mode	When the STANDBY pin is set to "Low", the internal OSC and motor output stage will be set to OFF status; therefore the motor will not be operational.

## Absolute maximum ratings (Ta = 25° C)

Characteristics	Symbol	Rating	Unit	Note
Motor power supply	VM	40	V	-
Motor output voltage	VOUT	40	V	-
Motor output current	IOUT	2.5	A	Note 1
VCC voltage	VCC	6.0	V	-
Digital input voltage	VIN(H)	6.0	V	-
	VIN(L)	-0.4	V	-
Power dissipation	QFN36 PD	1.15	W	Note 2
Operating temperature	TOPR	-20 to 85	°C	-
Storage temperature	TSTR	-55 to 150	°C	-
Junction temperature	Tj(max)	150	°C	-

Note 1: While in use, please make sure that the motor current is controlled to be under 80 % of the absolute maximum ratings. (In this case, about 2.0A (max) ).

Note 2: The value in the state where it is not mounted on the board

Ta: Ambient temperature.

Topr: Operating ambient temperature.

Tj: Operating junction temperature. The maximum junction temperature is limited by the thermal shutdown.

Note: Use the maximum junction temperature (Tj) at 120° C or less.

The maximum current cannot be used under certain thermal conditions.

### Note: The absolute maximum ratings

The absolute maximum ratings are a specification that must not be exceeded, even for a moment.

Exceeding the ratings may cause device breakdown, damage or deterioration, and may result in injury by explosion or combustion.

## Operating Ranges (Ta=0 to 85°C)

Characteristics	Symbol	Min	Typ	Max	Unit	Note
Motor power supply	VM	10	24	35	V	
Motor output current	IOUT	-	1.0	2.0	A	
Logic input voltage	VIN(H)	2.0	-	5.5	V	Logic 'High' level
	VIN(L)	0	-	0.8	V	Logic 'Low' level
CLK input frequency	fCLK	-	-	100	kHz	
PWM signal frequency range	fchop(range)	40	100	150	kHz	
VREF reference voltage	Vref	GND	3.0	3.6	V	
RS pin voltage	VRS	-	±1.0	±1.5	V	Reference value: VM

Note 1: The actual maximum current may be limited by the operating environment (operating conditions such as excitation mode or operating duration, or by the surrounding temperature or board heat dissipation). Determine a realistic maximum current by calculating the heat generated under the operating environment.

Note 2: The maximum VRS voltage should not exceed the maximum rated voltage.

## Electrical Specifications 1 (Ta=25°C, VM=24V, unless specified otherwise)

Characteristics		Symbol	Test Circuit	Test Condition	Min	Typ.	Max	Unit
Logic input pin voltage	HIGH	VIN(H)	DC	Logic input pins (Note)	2	–	5.5	V
	LOW	VIN(L)	DC	Logic input pins (Note)	0	–	0.8	V
Logic input voltage hysteresis		VIN(HYS)	DC	Logic input pins (Note)	100	–	300	mV
Logic input pin current	HIGH	IIN(H)	DC	Logic input pins; VIN=3.3V	–	33	50	μA
	LOW	IIN(L)	DC	Logic input pins; VIN=0V	–	–	1	μA
Power consumption		IM1	DC	Output:OPEN, Standby mode	–	2	3	mA
		IM2	DC	Output:OPEN, ENABLE=L	–	3.5	5	mA
		IM3	DC	Output:OPEN (Full step setting)	–	5	7	mA
Motor output leakage current	Hi-side	IOH	DC	VRS=VM=40V, VOUT=0V	–	–	1	μA
	Low-side	IOL	DC	VRS=VM=VOUT=40V	1	–	–	μA
Bridge-to-Bridge current differential		ΔIOUT1	DC	Channel A and B differential	–5	0	5	%
Output current error relative to the predetermined value		ΔIOUT2	DC	IOUT=1.0A	–5	0	5	%
RS pin current		IRS	DC	VRS=VM=24V	0	–	10	μA
Drain-source ON-resistance (The sum of high side & low side)		Ron(S)_PN		IOUT=2.0A, Tj=25°C, (Hi-side+Low side MOSFET)	–	0.53	0.75	Ω

Note: VIN (L → H) is defined as the VIN voltage that causes the outputs (OUT\_A+, OUT\_A-, OUT\_B+ and OUT\_B-) to change when a pin under test is gradually raised from 0 V. VIN (H → L) is defined as the VIN voltage that causes the outputs (OUT\_A+, OUT\_A-, OUT\_B+ and OUT\_B-) to change when the pin is then gradually lowered.

The difference between VIN (L → H) and VIN (H → L) is defined as the input hysteresis.

Note: The internal circuits are designed to avoid miss-function or leakage current; when the logic signal is applied while the VM voltage is not supplied. But for fail-safe, please control the power supply and logic signal timing correctly.

## Electrical Specifications 2 (Ta=25°C, VM=24V, unless specified otherwise)

Characteristics	Symbol	Test Circuit	Test Condition	Min	Typ.	Max	Unit
Vref input voltage	VREF	DC	VM=24V,VCC=5V	GND	3.0	3.6	V
Vref input current	IREF		VREF=3.0V	–	0	1	μA
VCC voltage	VCC		ICC=5.0mA	4.75	5.0	5.25	V
VCC current	ICC		VCC=5.0V	–	2.5	5	mA
Vref gain	VREF(gain)		VREF=2.0V	1/5.2	1/5.0	1/4.8	–
TSD threshold (Note1)	TjTSD		–	140	150	170	°C
VM POR threshold	VMR		–	7.0	8.0	9.0	V
Over current threshold (Note2)	ISD		–	(3.1)	(4.0)	(5.0)	A

Note 1: Thermal shutdown (TSD) circuit

When the junction temperature of the device reaches the TSD threshold, the TSD circuit is triggered; the internal reset circuit then turns off the output transistors. Once the TSD circuit is triggered, the device keeps the output off until power-on reset (POR), is reasserted or set to Standby mode.

Note 2: Over-current/voltage shutdown (ISD) circuit

When the output current or the RS pin voltage reaches the threshold, the ISD circuit is triggered; the internal reset circuit then turns off the output transistors. Once the ISD circuit is triggered, the device keeps the output off until power-on reset (POR), is reasserted or set to Standby mode.

For fail-safe, please insert a fuse to avoid secondary trouble.

## Back-EMF

While a motor is rotating, there is a timing at which power is fed back to the power supply. At that timing, the motor current recirculates back to the power supply due to the effect of the motor back-EMF.

If the power supply does not have enough sink capability, the power supply and output pins of the device might rise above the rated voltages. The magnitude of the motor back-EMF varies with usage conditions and motor characteristics. It must be fully verified that there is no risk that the TB67S213 or other components will be damaged or fail due to the motor back-EMF.

## Cautions on Overcurrent Shutdown (ISD) and Thermal Shutdown (TSD)

- The ISD and TSD circuits are only intended to provide temporary protection against irregular conditions such as an output short-circuit; they do not necessarily guarantee the complete IC safety.
- If the device is used beyond the specified operating ranges, these circuits may not operate properly: then the device may be damaged due to an output short-circuit.
- The ISD circuit is only intended to provide a temporary protection against an output short-circuit. If such a condition persists for a long time, the device may be damaged due to overstress. Overcurrent conditions must be removed immediately by external hardware.

## IC Mounting

Do not insert devices incorrectly or in the wrong orientation. Otherwise, it may cause breakdown, damage and/or deterioration of the device.

## Electrical Specifications 2 (Ta = 25° C, VM = 24 V, 6.8 mH/5.7 Ω)

Characteristics	Symbol	Test Circuit	Test Condition	Min	Typ.	Max	Unit
PHASE input frequency	fPHASE	AC	fOSC=1600kHz	-	-	150	kHz
Minimum PHASE High width	tPHASE(H)	AC	Minimum PHASE width: PHASE= 'H'	50	-	-	ns
Minimum PHASE Low width	tPHASE(L)	AC	Minimum PHASE width: PHASE= 'L'	50	-	-	ns
Output stage Switching specifications	tr	AC		150	200	250	ns
	tf	AC		100	150	200	ns
	tpLH(CLK)	AC	PHASE to OUT	250	-	1200	ns
	tpHL(CLK)	AC	PHASE to OUT	250	-	1200	ns
Analog noise rejection blank time	AtBLK	AC	VM=24V,IOUT=1.0A Analog tBLK	250	400	550	ns
Internal oscillator frequency	fOSC	AC	COSC= 270 pF, ROsc =3.6 kΩ	1360	1600	1840	kHz
Motor chopping frequency	fchop	AC	Output active (IOUT =1.0 A), fOSC = 1600 kHz	-	100	-	kHz

### AC timing chart

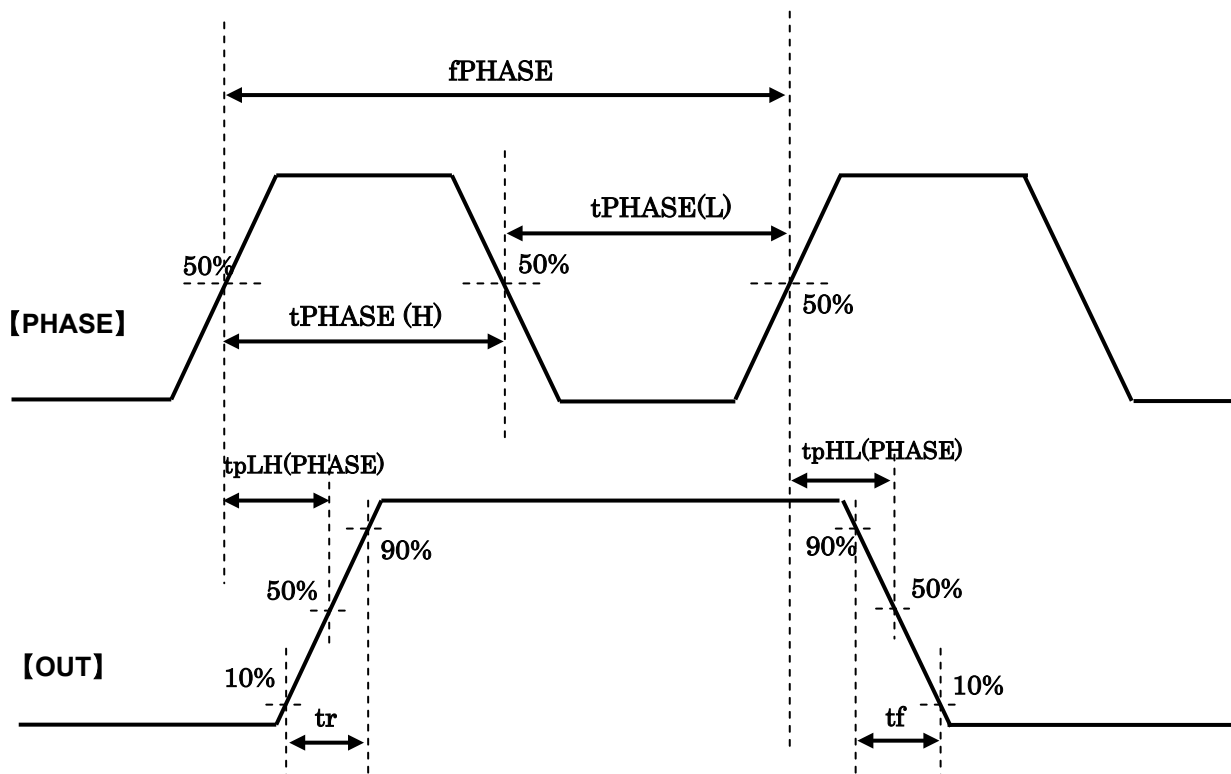

Timing charts may be simplified for explanatory purpose.

**Application Note**

**Motor control (Current feedback control)**

The 'Mixed Decay Timing' is a fixed value of 37.5% of 1 fchop cycle.

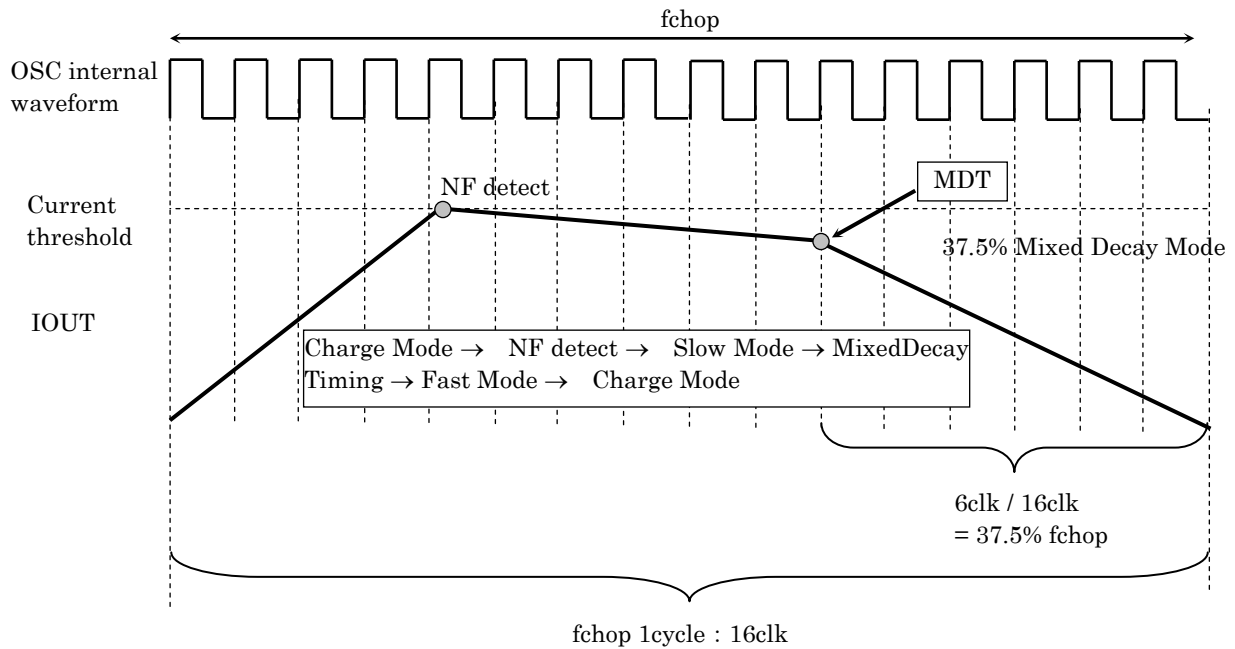

**Waveform of Mixed Decay Mode sequence (Motor current)**

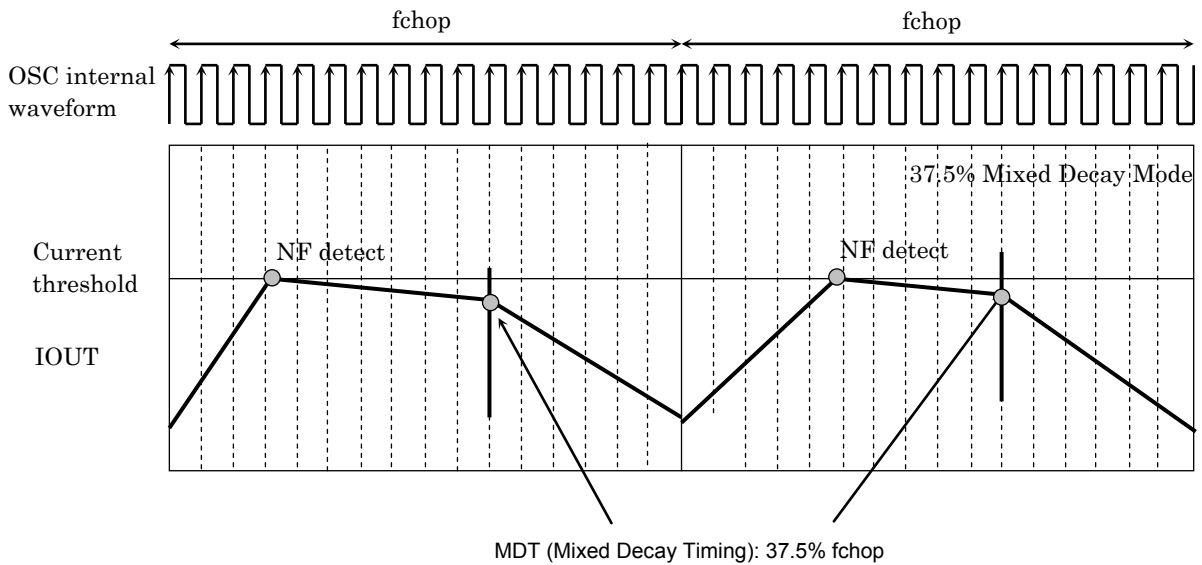

Timing charts may be simplified for explanatory purposes.

**Note: About Mixed Decay Timing**

Mixed Decay Timing (MDT) is a unique value of the TB67S213 ( $f_{chop} \times 37.5\%$ ), but when the motor output current reaches NF threshold after MDT, the rest of fchop (※) becomes fast decay mode.

## Mixed (Slow + Fast) Decay Mode current waveform

•When the next step's current threshold is above the previous step

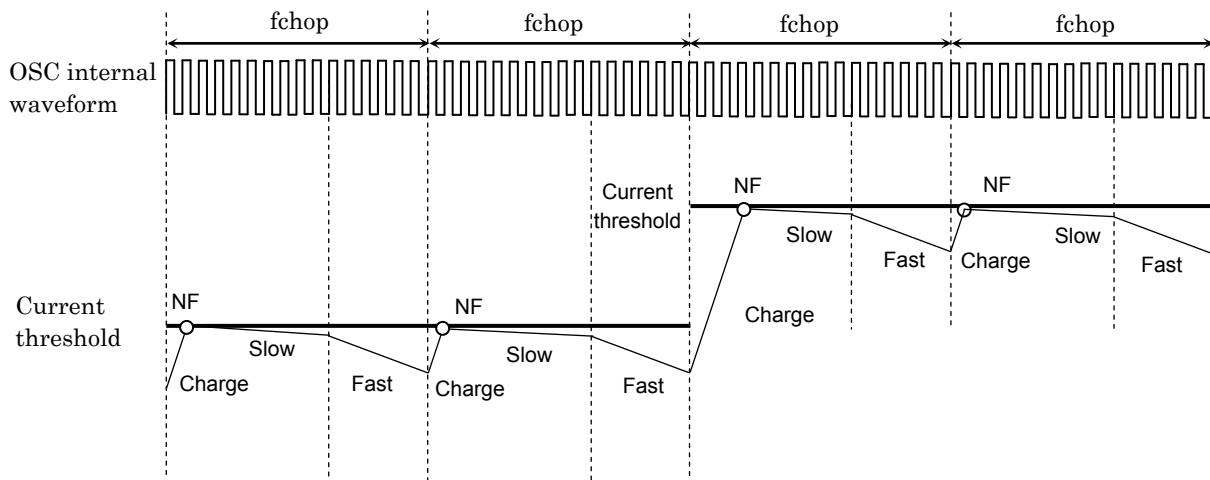

•When the next step's current threshold is below the previous step

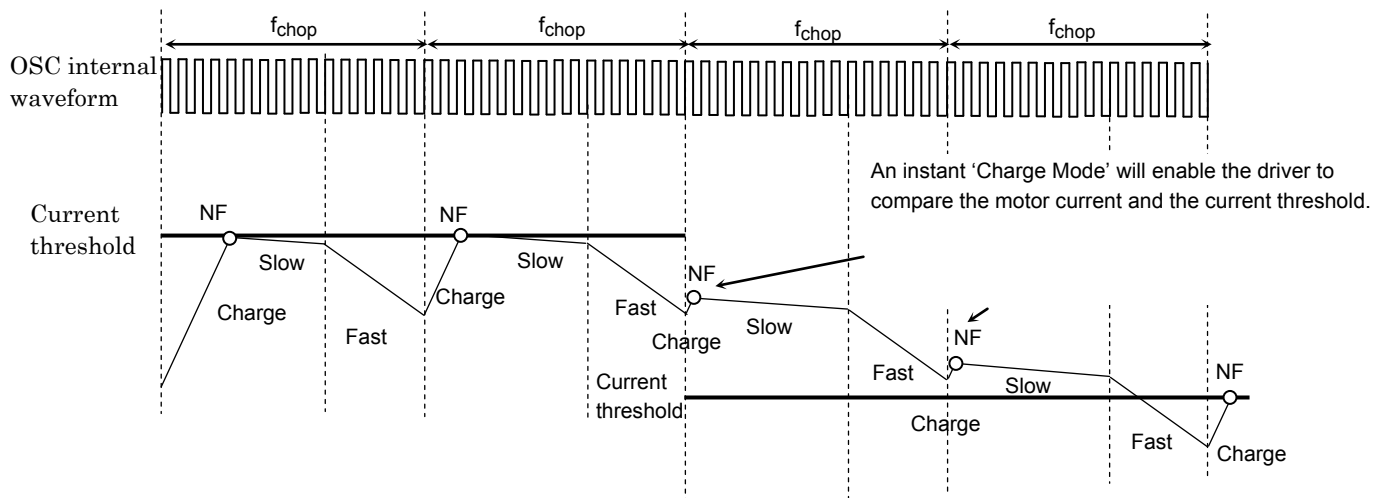

Timing charts may be simplified for explanatory purposes.

## Output Transistor Operation Mode

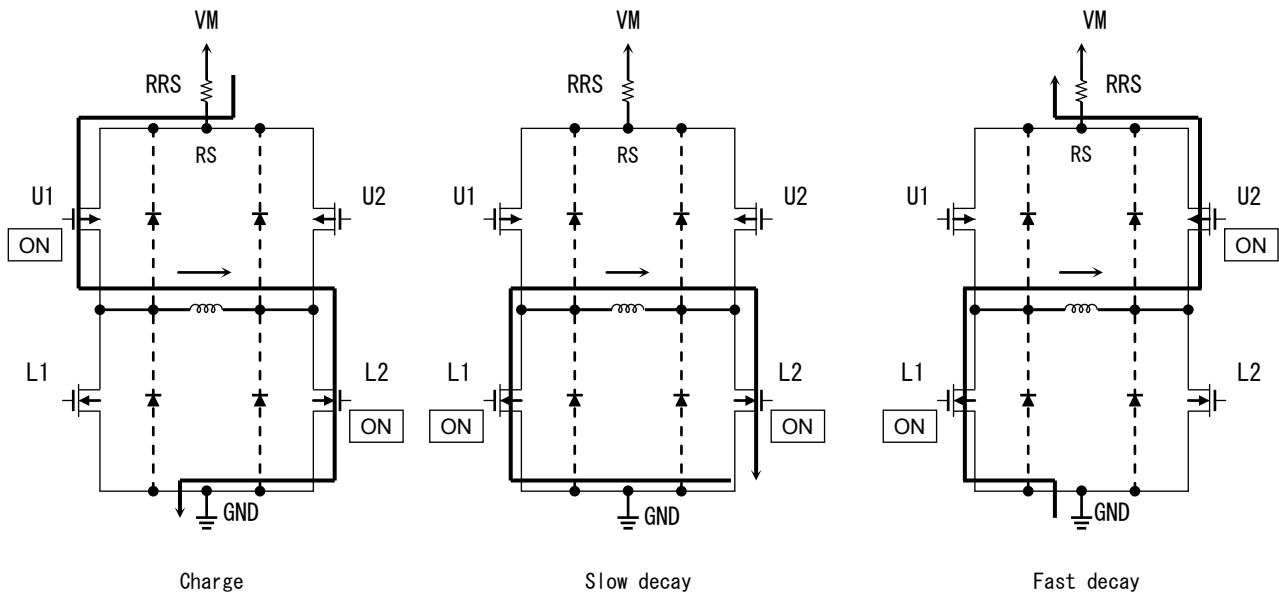

Some of the functional blocks, circuits, or constants omitted or simplified for explanatory purpose.

## Output Transistor Operational Function

Mode	U1	L1	U2	L2
Charge	ON	OFF	OFF	ON
Slow decay	OFF	ON	OFF	ON
Fast decay	OFF	ON	ON	OFF

Note: The parameters shown in the table above are examples when the current flows in the directions shown in the figures above. For the current flowing in the reverse direction, the parameters change as shown in the table below.

Mode	U1	L1	U2	L2
Charge	OFF	ON	ON	OFF
Slow decay	OFF	ON	OFF	ON
Fast decay	ON	OFF	OFF	ON

### Calculation of the Predefined Output Current

For PWM constant-current control, the TB67S213FTAG uses a clock generated by the CR oscillator. The peak output current can be set via the current-sensing resistor (RRS) and the reference voltage (Vref), as follows:

$$I_{OUT} = V_{ref}/5 \div RRS (\Omega)$$

where, 1/5 is the Vref decay rate, Vref (GAIN). For the value of Vref (GAIN), see the Electrical Characteristics table. For example, when Vref = 3 V, to set the current feedback threshold (Iout)=1.8A, RS resistance is calculated as:

$$RRS = (V_{ref} / 5) \div I_{OUT} = (3/5) \div 1.8 = 0.33 \Omega. (\geq 1.1 \text{ W})$$

### Calculation of the OSCM oscillation frequency (chopper reference frequency)

An approximation of the OSCM oscillation frequency (fOSCM) and chopper frequency (fchop) can be calculated by the following expressions.

$$f_{OSCM} = 1 / [0.56 \times (C_x(R_1 + 500))] \quad \dots\dots\dots C, R_1: \text{External components for OSCM } (C=270\text{pF}, R=3.6\text{k}\Omega \Rightarrow 1.6\text{MHz})$$

$$f_{chop} = f_{OSCM} / 16$$

### IC Power Consumption

The power consumed by the TB67S213FTAG is approximately the sum of the following:

- 1) the power consumed by the output transistors
- 2) the power consumed by the digital logic and pre-drivers.

The power consumed by the output transistors is calculated, using the RON (D-S) value of 0.6Ω (typ).

An approximation of the peak power consumption for H-SW can be calculated by the following expressions.

$$P(\text{out}) = H\text{-SW}(\text{ch}) \times I_{out}(\text{A}) \times I_{out}(\text{A}) \times R_{on}(\Omega) \quad (1)$$

In full step operation (for example, 1.0A), the average power consumption in the output stage is calculated as follows:

$$\begin{aligned} R_{on} &= 0.6 \Omega, I_{out} = 1.0 \text{ A}, VM = 24 \text{ V} \\ P(\text{out}) &= 2(\text{ch}) \times 1.0(\text{A})^2 \times 0.6(\Omega) && (2) \\ &= 1.2(\text{W}) \end{aligned}$$

The power consumption in the IM domain is calculated as:

$$\begin{aligned} P(\text{IM}) &= 24(\text{V}) \times 0.005(\text{A}) && (3) \\ &= 0.12(\text{W}) \end{aligned}$$

$$(IM3) = 5.0 \text{ mA (typ.)}, VM=24\text{V}$$

All over, the total peak power consumption of TB67S213FTAG is:

$$P = P(\text{out}) + P(\text{IM}) = 1.32(\text{W})$$

Board design should be fully verified, taking thermal dissipation into consideration.

## Step resolution timing charts (PHASE-IN)

[Full step resolution]

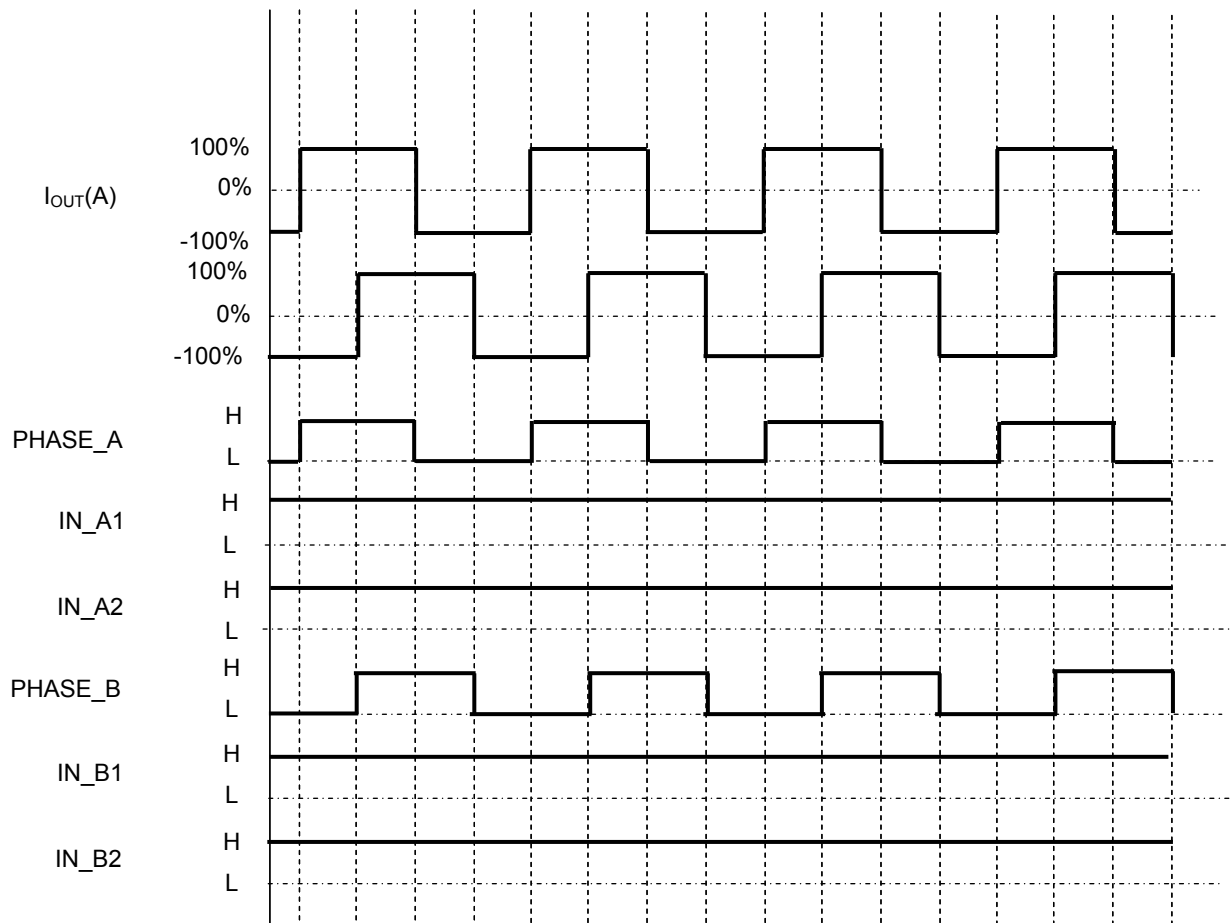

Timing charts may be simplified for explanatory purposes.

[Half step resolution]

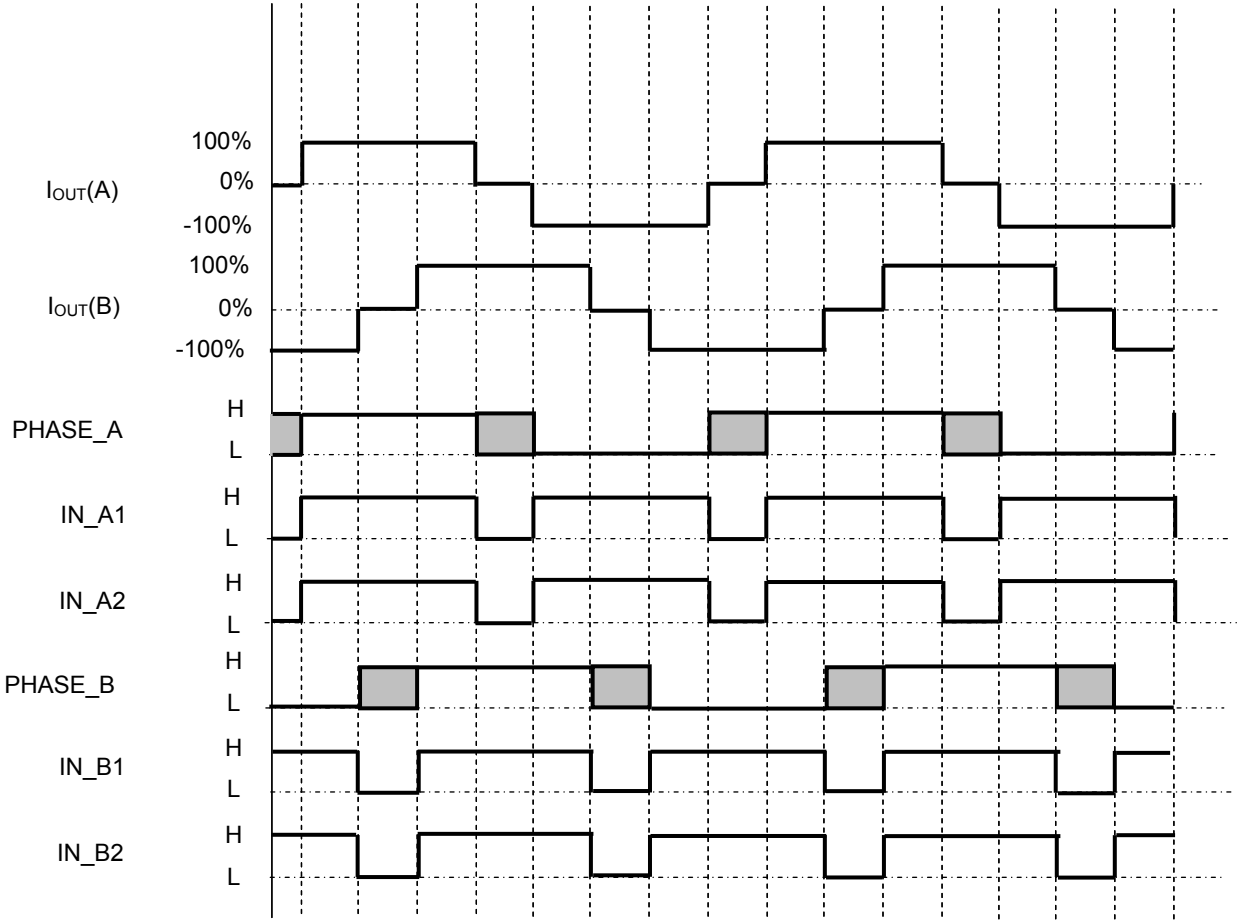

Timing charts may be simplified for explanatory purposes.

## [Quarter step resolution]

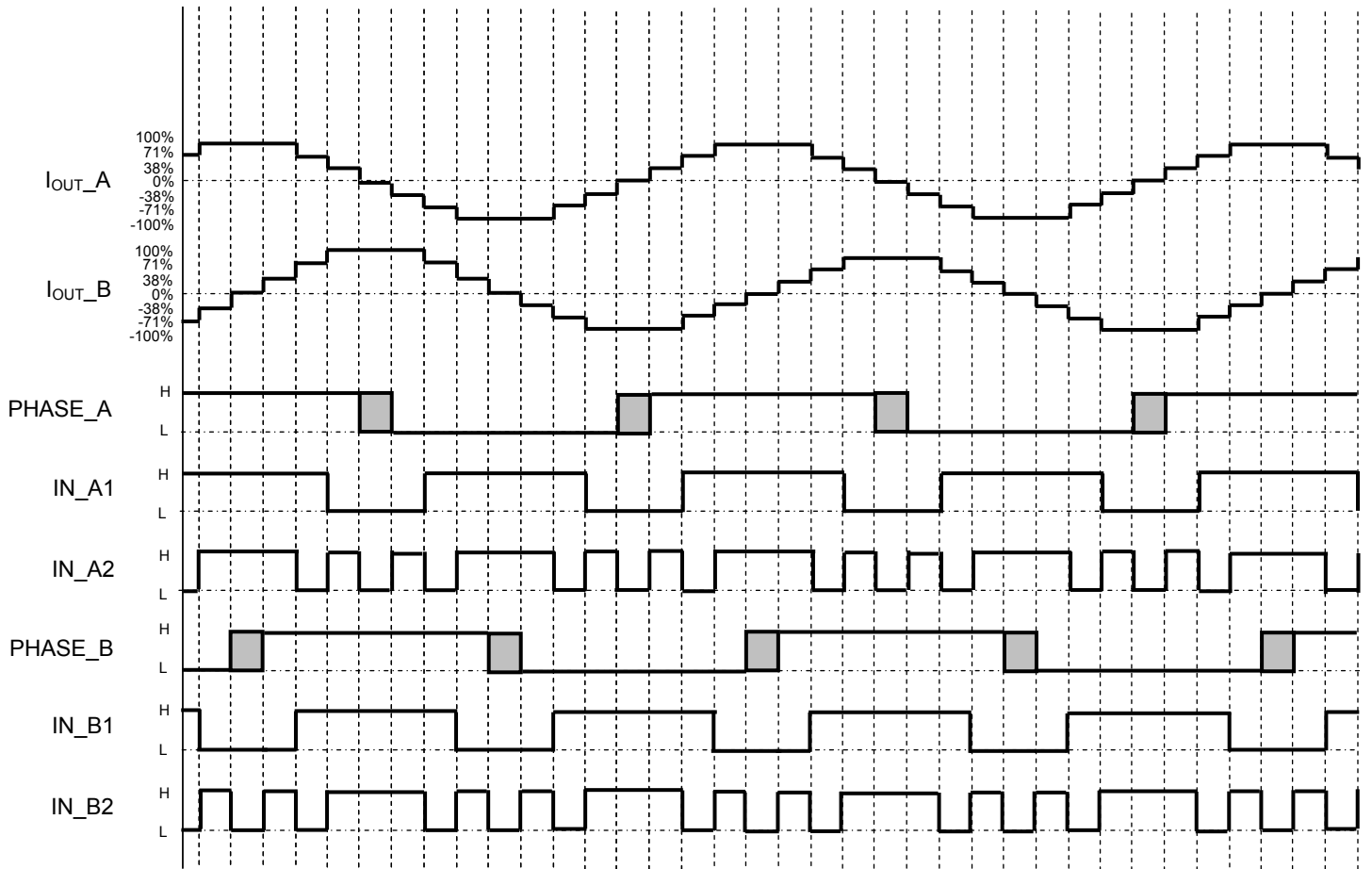

Timing charts may be simplified for explanatory purposes.

## Example Application Circuits

The values shown in the following figure are typical values. For input conditions, see the Operating Ranges.

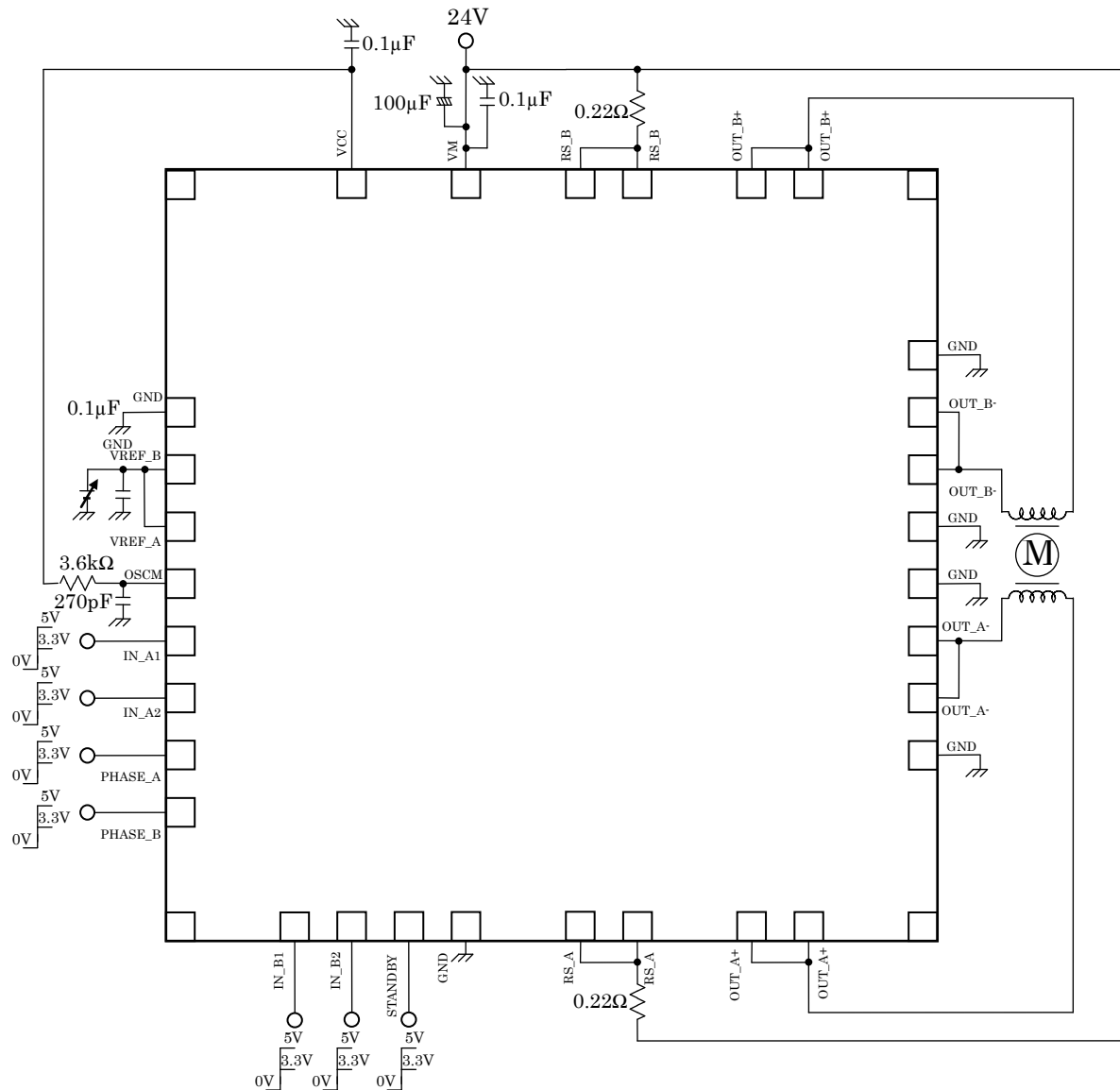

Note: Bypass capacitors should be added as necessary. It is recommended to use a single ground plane for the entire board whenever possible.

The above application circuit example is presented only as a guide and should be fully evaluated prior to production. Also, no intellectual property right is ceded in any way whatsoever in regard to its use.

## Package Dimensions

P-WQFN36-0606-0.50-002

Unit:mm

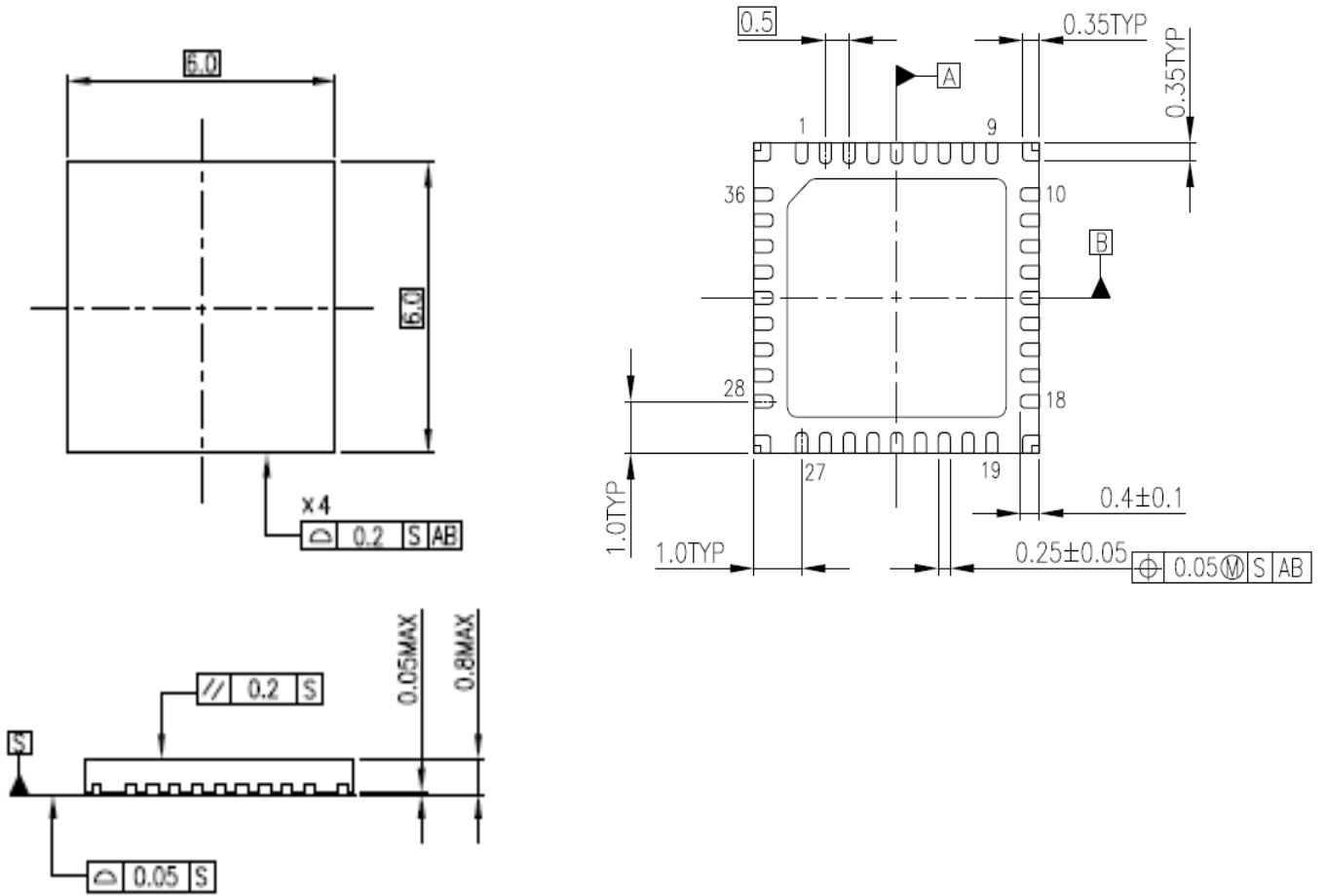

## Notes on Contents

### Block Diagrams

Some of the functional blocks, circuits, or constants in the block diagram may be omitted or simplified for explanatory purposes.

### Equivalent Circuits

The equivalent circuit diagrams may be simplified or some parts of them may be omitted for explanatory purposes.

### Timing Charts

Timing charts may be simplified for explanatory purposes.

### Application Circuits

The application circuits shown in this document are provided for reference purposes only. Thorough evaluation is required at the mass production design stage. Toshiba does not grant any license to any industrial property rights by providing these examples of application circuits.

### Test Circuits

Components in the test circuits are used only to obtain and confirm the device characteristics. These components and circuits are not guaranteed to prevent malfunction or failure from occurring in the application equipment.

## IC Usage Considerations

### Notes on handling of ICs

The absolute maximum ratings of a semiconductor device are a set of ratings that must not be exceeded, even for a moment. Do not exceed any of these ratings. Exceeding the rating(s) may cause device breakdown, damage or deterioration, and may result in injury by explosion or combustion.

Use an appropriate power supply fuse to ensure that a large current does not continuously flow in the case of over-current and/or IC failure. The IC will fully break down when used under conditions that exceed its absolute maximum ratings, when the wiring is routed improperly or when an abnormal pulse noise occurs from the wiring or load, causing a large current to continuously flow and the breakdown can lead to smoke or ignition. To minimize the effects of the flow of a large current in the case of breakdown, appropriate settings, such as fuse capacity, fusing time and insertion circuit location, are required.

If your design includes an inductive load such as a motor coil, incorporate a protection circuit into the design to prevent device malfunction or breakdown caused by the current resulting from the inrush current at power ON or the negative current resulting from the back electromotive force at power OFF. IC breakdown may cause injury, smoke or ignition. Use a stable power supply with ICs with built-in protection functions. If the power supply is unstable, the protection function may not operate, causing IC breakdown. IC breakdown may cause injury, smoke or ignition.

Do not insert devices in the wrong orientation or incorrectly. Make sure that the positive and negative terminals of power supplies are connected properly. Otherwise, the current or power consumption may exceed the absolute maximum rating, and exceeding the rating(s) may cause device breakdown, damage or deterioration, and may result in injury by explosion or combustion. In addition, do not use any device that has been inserted incorrectly.

Please take extra care when selecting external components (such as power amps and regulators) or external devices (for instance, speakers). When large amounts of leak current occurs from capacitors, the DC output level may increase. If the output is connected to devices such as speakers with low resist voltage, overcurrent or IC failure may cause smoke or ignition. (The over-current may cause smoke or ignition from the IC itself.) In particular, please pay attention when using a Bridge Tied Load (BTL) connection-type IC that inputs output DC voltage to a speaker directly.

## Points to remember on handling of ICs

### Over current detection circuit

Over current detection circuits (referred to as current limiter circuits) do not necessarily protect ICs under all circumstances. If the Over current detection circuits operate against the over current, clear the over current status immediately.

Depending on the method of use and usage conditions, such as exceeding absolute maximum ratings can cause the over current protection circuit to not operate properly or IC breakdown before operation. In addition, depending on the method of use and usage conditions, if over current continues to flow for a long time after operation, the IC may generate heat resulting in breakdown.

### Thermal Shutdown Circuit

Thermal shutdown circuits do not necessarily protect ICs under all circumstances. If the thermal shutdown circuits operate against the over temperature, clear the heat generation status immediately.

Depending on the method of use and usage conditions, such as exceeding absolute maximum ratings can cause the thermal shutdown circuit to not operate properly or IC breakdown before operation.

### Heat Radiation Design

In using an IC with large current flow such as power amp, regulator or driver, please design the device so that heat is appropriately radiated, not to exceed the specified junction temperature (T<sub>J</sub>) at any time and condition. These ICs generate heat even during normal use. An inadequate IC heat radiation design can lead to decrease in IC life, deterioration of IC characteristics or IC breakdown. In addition, please design the device taking into consideration the effect of IC heat radiation with peripheral components.

### Back-EMF

When a motor rotates in the reverse direction, stops or slows down abruptly, a current flow back to the motor's power supply due to the effect of back-EMF. If the current sink capability of the power supply is small, the device's motor power supply and output pins might be exposed to conditions beyond maximum ratings. To avoid this problem, take the effect of back-EMF into consideration in system design.

## RESTRICTIONS ON PRODUCT USE

- Toshiba Corporation, and its subsidiaries and affiliates (collectively "TOSHIBA"), reserve the right to make changes to the information in this document, and related hardware, software and systems (collectively "Product") without notice.
- This document and any information herein may not be reproduced without prior written permission from TOSHIBA. Even with TOSHIBA's written permission, reproduction is permissible only if reproduction is without alteration/omission.
- Though TOSHIBA works continually to improve Product's quality and reliability, Product can malfunction or fail. Customers are responsible for complying with safety standards and for providing adequate designs and safeguards for their hardware, software and systems which minimize risk and avoid situations in which a malfunction or failure of Product could cause loss of human life, bodily injury or damage to property, including data loss or corruption. Before customers use the Product, create designs including the Product, or incorporate the Product into their own applications, customers must also refer to and comply with (a) the latest versions of all relevant TOSHIBA information, including without limitation, this document, the specifications, the data sheets and application notes for Product and the precautions and conditions set forth in the "TOSHIBA Semiconductor Reliability Handbook" and (b) the instructions for the application with which the Product will be used with or for. Customers are solely responsible for all aspects of their own product design or applications, including but not limited to (a) determining the appropriateness of the use of this Product in such design or applications; (b) evaluating and determining the applicability of any information contained in this document, or in charts, diagrams, programs, algorithms, sample application circuits, or any other referenced documents; and (c) validating all operating parameters for such designs and applications. **TOSHIBA ASSUMES NO LIABILITY FOR CUSTOMERS' PRODUCT DESIGN OR APPLICATIONS.**
- **PRODUCT IS NEITHER INTENDED NOR WARRANTED FOR USE IN EQUIPMENTS OR SYSTEMS THAT REQUIRE EXTRAORDINARILY HIGH LEVELS OF QUALITY AND/OR RELIABILITY, AND/OR A MALFUNCTION OR FAILURE OF WHICH MAY CAUSE LOSS OF HUMAN LIFE, BODILY INJURY, SERIOUS PROPERTY DAMAGE AND/OR SERIOUS PUBLIC IMPACT ("UNINTENDED USE").** Except for specific applications as expressly stated in this document, Unintended Use includes, without limitation, equipment used in nuclear facilities, equipment used in the aerospace industry, Class 3 medical devices, equipment used for automobiles, and military vehicles and munitions. **IF YOU USE PRODUCT FOR UNINTENDED USE, TOSHIBA ASSUMES NO LIABILITY FOR PRODUCT.** For details, please contact your TOSHIBA sales representative or contact us via our website.
- Do not disassemble, analyze, reverse-engineer, alter, modify, translate or copy Product, whether in whole or in part.
- Product shall not be used for or incorporated into any products or systems whose manufacture, use, or sale is prohibited under any applicable laws or regulations.
- The information contained herein is presented only as guidance for Product use. No responsibility is assumed by TOSHIBA for any infringement of patents or any other intellectual property rights of third parties that may result from the use of Product. No license to any intellectual property right is granted by this document, whether express or implied, by estoppel or otherwise.
- **ABSENT A WRITTEN SIGNED AGREEMENT, EXCEPT AS PROVIDED IN THE RELEVANT TERMS AND CONDITIONS OF SALE FOR PRODUCT, AND TO THE MAXIMUM EXTENT ALLOWABLE BY LAW, TOSHIBA (1) ASSUMES NO LIABILITY WHATSOEVER, INCLUDING WITHOUT LIMITATION, INDIRECT, CONSEQUENTIAL, SPECIAL, OR INCIDENTAL DAMAGES OR LOSS, INCLUDING WITHOUT LIMITATION, LOSS OF PROFITS, LOSS OF OPPORTUNITIES, BUSINESS INTERRUPTION AND LOSS OF DATA, AND (2) DISCLAIMS ANY AND ALL EXPRESS OR IMPLIED WARRANTIES AND CONDITIONS RELATED TO SALE, USE OF PRODUCT, OR INFORMATION, INCLUDING WARRANTIES OR CONDITIONS OF MERCHANTABILITY, FITNESS FOR A PARTICULAR PURPOSE, ACCURACY OF INFORMATION, OR NONINFRINGEMENT.**
- Do not use or otherwise make available Product or related software or technology for any military purposes, including without limitation, for the design, development, use, stockpiling or manufacturing of nuclear, chemical, or biological weapons or missile technology products (mass destruction weapons). Product and related software and technology may be controlled under the applicable export laws and regulations including, without limitation, the Japanese Foreign Exchange and Foreign Trade Law and the U.S. Export Administration Regulations. Export and re-export of Product or related software or technology are strictly prohibited except in compliance with all applicable export laws and regulations.
- Please contact your TOSHIBA sales representative for details as to environmental matters such as the RoHS compatibility of Product. Please use Product in compliance with all applicable laws and regulations that regulate the inclusion or use of controlled substances, including without limitation, the EU RoHS Directive. **TOSHIBA ASSUMES NO LIABILITY FOR DAMAGES OR LOSSES OCCURRING AS A RESULT OF NONCOMPLIANCE WITH APPLICABLE LAWS AND REGULATIONS.**