

**LDO Regulator TCR15AG
(fixed output voltage type)
Application & Circuit
Reference Guide**

RD030-RGUIDE-02

TOSHIBA ELECTRONIC DEVICES & STORAGE CORPORATION

Table of Contents

1. OVERVIEW	3
1.1. Target applications	4
2. APPLICATION CIRCUIT EXAMPLE AND BILL OF MATERIALS	5
2.1. Application circuit example	5
2.2. Bill of materials.....	5
3. MAJOR FEATURES OF THE TCR15AG SERIES	6
3.1. V_{BIAS} pin.....	6
3.2. Achieving a high PSRR and the influence of an output capacitor on the PSRR	9
3.3. Achieving a fast high-load transient response	10
4. OUTPUT VOLTAGE.....	12
5. DESIGN CONSIDERATIONS.....	14
6. PRODUCT OVERVIEW.....	15
6.1. TCR15AG (fixed voltage type)	15
6.1.1. Overview	15
6.1.2. External view and pin assignment	15
6.1.3. Internal block diagram.....	17
6.1.4. Pin description	17

1. Overview

For the purpose of requiring low power consumption application, it is general that average power consumption goes down balancing total system utilization and supplying power. Especially smartphone and tablet, there is a trade-off between the size and weight of the device and their battery capacity while a high level of power management is necessary, but in the application there are various electronic circuits including wireless communication, camera, display, audio, and storage circuits, so it is necessary to control their power supplies surely.

Power management ICs (PMICs) are used in smartphones, tablets, and other small battery-operated devices to achieve accurate power management. A PMIC consists of a few to a few dozen power supply channels of DC-DC converters and low-dropout (LDO) regulators, and a controller to control the on/off of each power supply and output according to commands from a main system-on-a-chip (SoC). PMICs specifically designed for smartphone and tablet applications, are constrained by size limits. Therefore, the power supply ICs integrated in some of these PMICs do not compare favorably with discrete power supply ICs in terms of performance. The power supplies from a PMIC might not satisfy system requirements, depending on the loads (ICs and modules) that they serve. In addition, mobile devices with wireless communication capabilities might generate electromagnetic interference (EMI) that affects bad impact to not only the communication quality but also internal power supply circuits. PMICs are generally designed for applications that are not subject to frequent remodeling. However, smartphones are upgraded frequently to add new features and improve performance, and each upgrade entails changes to the specifications of internal circuits. It is therefore impractical to rely on a single PMIC for the power management of all the internal circuits from the viewpoints of both system design and PMIC design.

In addition, with the global uptake of the LTE wireless standard, many smartphone users now share photographs and movies on SNS. This is driving substantial improvement in the performance of smartphone cameras, which have a CMOS image sensor with low power consumption and high read speed. Generally, it is necessary to supply different voltages to the sensor, core (control) and I/O sections of a CMOS image sensor. The digital core of a CMOS image sensor that processes data at high speed tends to consume a lot of power. Nowadays, the digital core is designed to operate at a very low voltage (around 1 V) to reduce power consumption. In order to accommodate the decreasing voltage and increasing current consumption, the power supply for the digital core needs to have excellent AC characteristics, including a high power supply rejection ratio (PSRR) and a fast load transient response, while providing a high current drive capability. Ultra-small packaging is also an important factor for space-critical designs like smartphones.

In addition to the V_{IN} input, Toshiba's LDO regulators of the TCR15AG series have a separate power supply for the output circuit in order to achieve low dropout voltage and thus stable voltage regulation even at low input voltage. The TCR15AG series provides outstanding PSRR and load transient response required for CMOS image sensors for smartphone applications. In addition, the TCR15AG series offers 46 LDO regulators with a fixed output voltage from 0.65V to 3.6V to meet a wide range of application requirements. While providing accurate voltage regulation, all the LDO regulators of the TCR15AG series are available in an ultra-small, thin-profile WCSP package.

Furthermore, the TCR15AG series has a drive capability of up to 1.5 A and thus meets the current requirement of CMOS image sensors, and provides overcurrent protection, thermal shutdown, inrush current limiting, undervoltage lockout, and auto output discharge.

This reference guide uses the TCR15AG (fixed voltage type) LDO regulator as an example to describe the major features and characteristics of the TCR15AG series. For details of other features and functions of the TCR15AG series, see datasheet.

To download the datasheet for the TCR15AG series → [Click Here](#)

1.1. Target applications

- Power supply circuits for CMOS image sensors and RF blocks/modules for smartphone applications

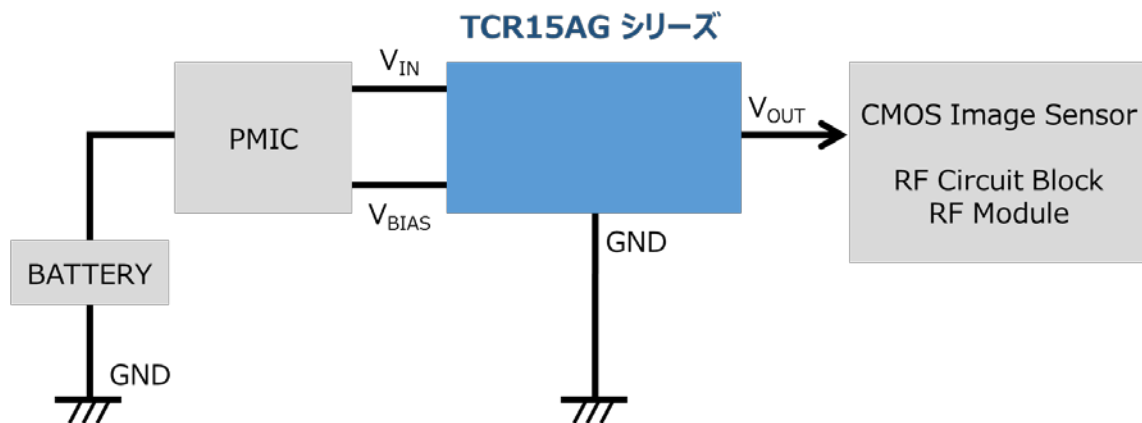

2. Application circuit example and bill of materials

2.1. Application circuit example

Figure 2.1 shows an example of a circuit using the TCR15AG (fixed voltage type) LDO regulator.

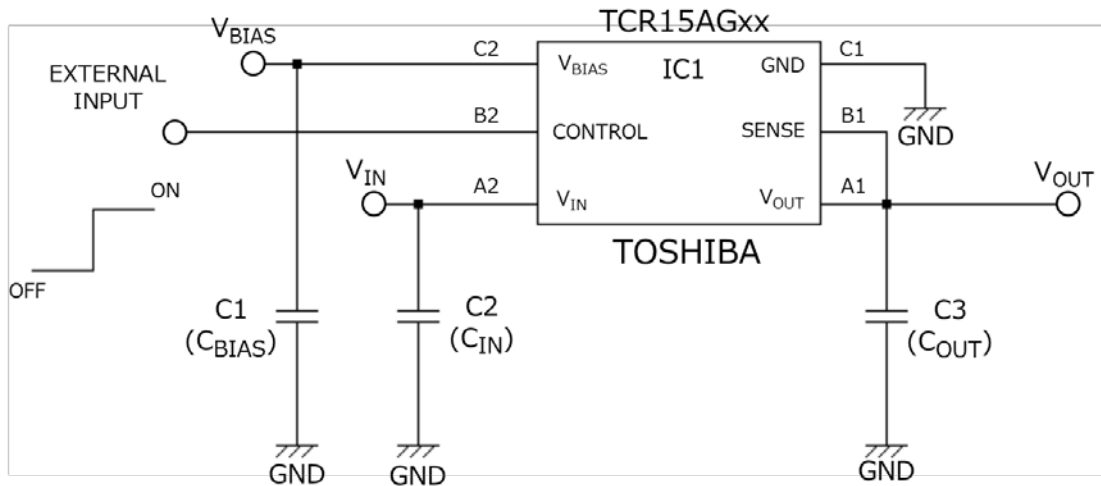

V_{BIAS} voltage conditions:

$$V_{OUT} \leq 1.1V \quad 2.5 \text{ to } 5.5V$$

$$V_{OUT} > 1.1V \quad V_{OUT}+1.4 \text{ to } 5.5V$$

V_{IN} and V_{BIAS} can be connected together if they meet the above

Figure 2.1 Example of a circuit using the TCR15AG (fixed voltage type) LDO regulator

2.2. Bill of materials

Table 2.1 Bill of materials

No.	Ref.	Qty	Value	Part Number	Manufacturer	Description	Packaging	Typical Dimensions mm (inches)
1	IC1	1	—	TCR15AG (fixed voltage type)	TOSHIBA		WCSP6F	1.2 x 0.8
2	C1 (C_{BIAS})	1	1.0 μ F			Ceramic, 10V, \pm 10%	—	1.0 x 0.5 (0402)
3	C2 (C_{IN})	1	4.7 μ F			Ceramic, 10V, \pm 10%	—	1.6 x 0.8 (0603)
4	C3 (C_{OUT})	1	4.7 μ F			Ceramic, 10V, \pm 10%	—	1.6 x 0.8 (0603)

3. Major features of the TCR15AG series

Fabricated using a CMOS process, the LDO regulators of the TCR15AG series feature low current consumption and small size. With small process geometries, the output device of the TCR15AG series has low on-resistance and thus a low input-output voltage differential (i.e., dropout voltage). LDO regulators with a low dropout voltage help reduce the thermal loss and increase the running time of battery-operated devices.

The TCR15AG series has a bias voltage input (V_{BIAS}) separate from the V_{IN} input, making it possible to reduce dropout voltage to a level lower than that achievable with the conventional CMOS process. Due to this circuit configuration, the TCR15AG series provides much lower dropout voltage than typical CMOS LDO regulators and thus helps reduce thermal loss. As a result, despite the ultra-small WCSP package, the TCR15AG series has a current drive capability of 1.5A. Being independent of the V_{IN} input of the LDO regulator, the V_{BIAS} pin helps the TCR15AG series achieve stable voltage regulation, even in the low input voltage region, without being affected by V_{IN} . The output voltage is as low as 0.65V. The following subsections show the unique characteristics of the TCR15AG series derived from the V_{BIAS} pin.

3.1. V_{BIAS} pin

Figure 3.1 shows a conventional LDO regulator. Operating with a power supply from V_{IN} , this LDO regulator drives the gate of an internal P-channel MOSFET with V_{IN} to provide an output voltage. Consequently, when V_{IN} is low, the MOSFET gate voltage decreases to a level that makes it impossible for the LDO regulator to maintain a regulated output voltage. Even when a low output voltage is necessary, a conventional LDO regulator is restricted by the lower limit of input operating voltage range specified in the datasheet. Therefore, despite the superior low-dropout advantage, conventional LDO regulators are not well suited for applications requiring a regulated low-voltage supply.

By way of comparison, Figure 3.2 shows the internal configuration of the TCR15AG series, which drives the gate of an internal MOSFET with a power supply from the V_{BIAS} pin. Being independent of the V_{IN} input, the V_{BIAS} pin provides several benefits. First, this configuration allows the use of an N-channel MOSFET. Since it is easier to reduce the on-resistance of the N-channel MOSFET than that of the P-channel MOSFET, the use of an N-channel MOSFET makes it possible to reduce dropout voltage. This, in turn, helps reduce power loss and therefore achieve a high-current drive capability. Second, the LDO regulator can operate at a low input voltage irrespective of V_{IN} and provides a regulated low output voltage with minimum power loss. Next, let's look at the changes in characteristics over a range of voltage applied to the V_{BIAS} pin.

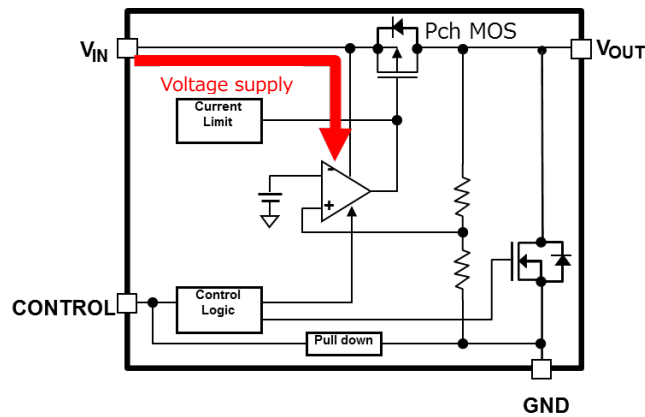

Figure 3.1 Gate voltage supply of the internal MOSFET of an LDO regulator without the V_{BIAS} pin

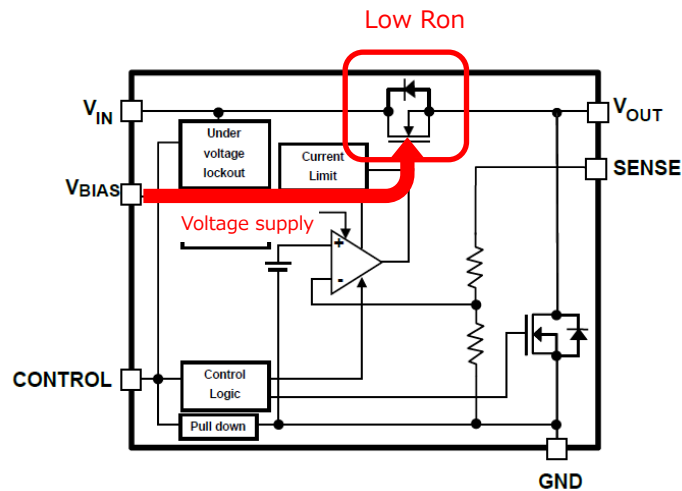

Figure 3.2 Gate voltage supply of the internal MOSFET of an LDO regulator with the V_{BIAS} pin

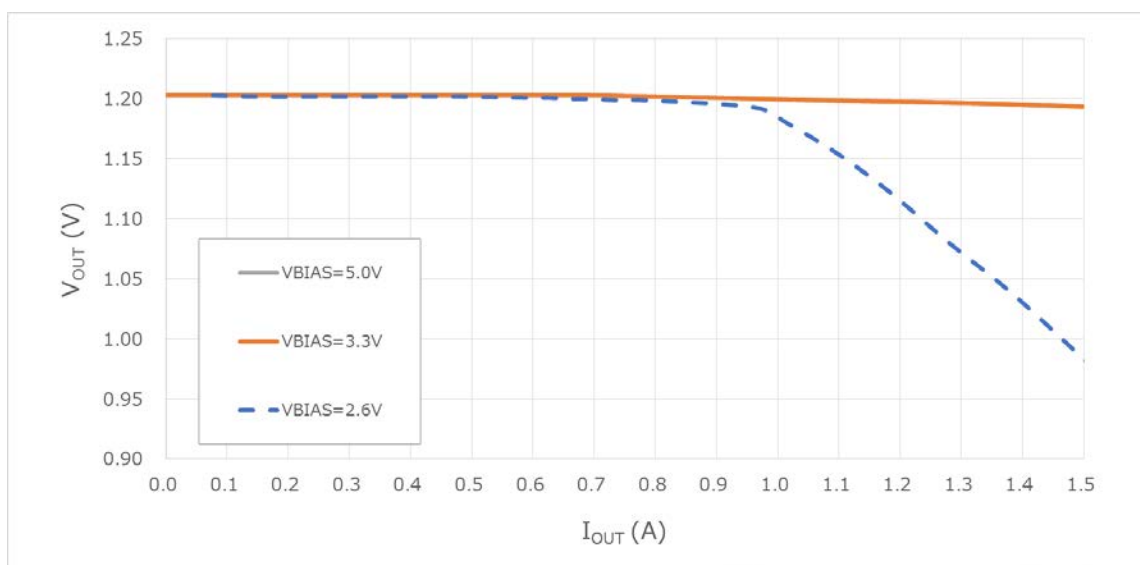

Figure 3.3 V_{OUT} - I_{OUT} curve with different V_{BIAS} voltages

Figure 3.3 shows the V_{OUT} - I_{OUT} curves of the TCR15AG12 ($V_{OUT}=1.2V$) at different V_{BIAS} voltages. As shown in Figure 3.3, when the V_{BIAS} pin is 3.3V or higher, the TCR15AG12 maintains low-dropout performance over the entire output current range of up to 1.5A. The minimum V_{BIAS} voltage shown in the datasheet is a voltage at which the functional operation of the TCR15AG12 is guaranteed under the specified test conditions. Care should be taken as to variations in performance depending on the V_{BIAS} voltage. The minimum V_{BIAS} voltage specified in the datasheet is 2.6V when $V_{OUT} = 1.2V$. The dashed curve shows the V_{OUT} - I_{OUT} characteristics when $V_{BIAS}=2.6V$. In contrast, the solid line shows the V_{OUT} - I_{OUT} performance when $V_{BIAS}=3.3V$. Compared to the solid line, the V_{OUT} - I_{OUT} curve at $V_{BIAS} = 2.6V$ begins to decline at an I_{OUT} around 0.5A. Therefore, for systems requiring a current of 0.5A or more, a 3.3V or higher power supply should be applied to the V_{BIAS} pin. However, this causes some design concerns. For example, depending on the system configuration, a long power supply line might need to run around a board, making it susceptible to noise. Another concern is that a system might be unable to supply enough power to the V_{BIAS} pin. Generally, the impact of a long and complex power supply line can be fixed by adding a $1\mu F$ capacitor to the V_{BIAS} pin as shown in Figure 2.1 or selecting an optimal capacitor while checking the output waveform from an actual system board. In order to ensure output voltage regulation, a $1\mu F$ or larger capacitor should be placed even if V_{BIAS} is free from noise. Since the sink current (I_{BIAS}) running into the V_{BIAS} pin is roughly $20\mu A$ at the maximum as shown in Figure 3.4, it is usually unnecessary to be concerned about a voltage drop caused by an insufficient power supply to the V_{BIAS} pin.

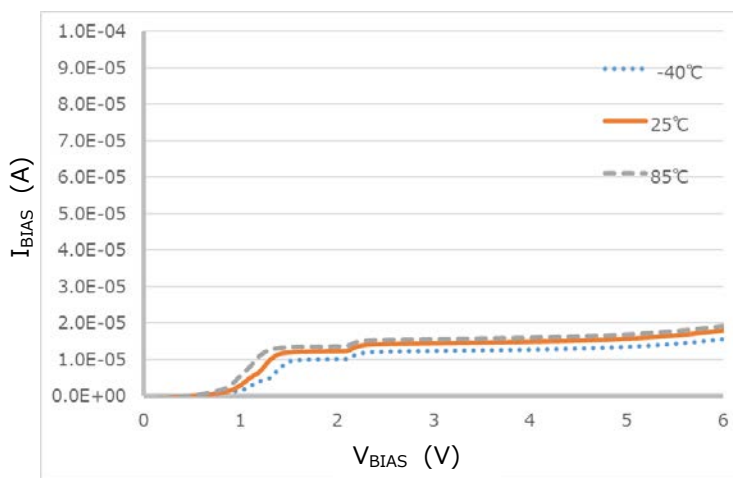

Figure 3.4 I_{BIAS} - V_{BIAS} curves

If the power supply to the V_{BIAS} pin is connected to other loads in parallel, a sudden change in any of their load currents could cause sudden drop the V_{BIAS} voltage. In order to maintain the V_{BIAS} pin at a proper voltage even in this situation, a $1\mu F$ or greater capacitor should be placed to the V_{BIAS} pin as shown in Figure 2.1.

3.2. Achieving a high PSRR and the influence of an output capacitor on the PSRR

In order to achieve a low dropout voltage and a high current-drive capability of 1.5A, the TCR15AG series drives an internal MOSFET with a supply voltage from the V_{BIAS} pin separate from V_{IN} . With a low dropout voltage performance, the TCR15AG series can regulate a low output voltage at a low input voltage, so it suits high-current applications such as CMOS image sensors and RF circuit blocks/modules. Important parameters for these applications include the PSRR that affects the amount of noise on a power supply to the load circuit and the load transient response, i.e., the response to sudden changes in the load current that occurs in high-speed digital signal processing circuits. Figure 3.5 shows the PSRR-frequency characteristics of the TCR15AG series.

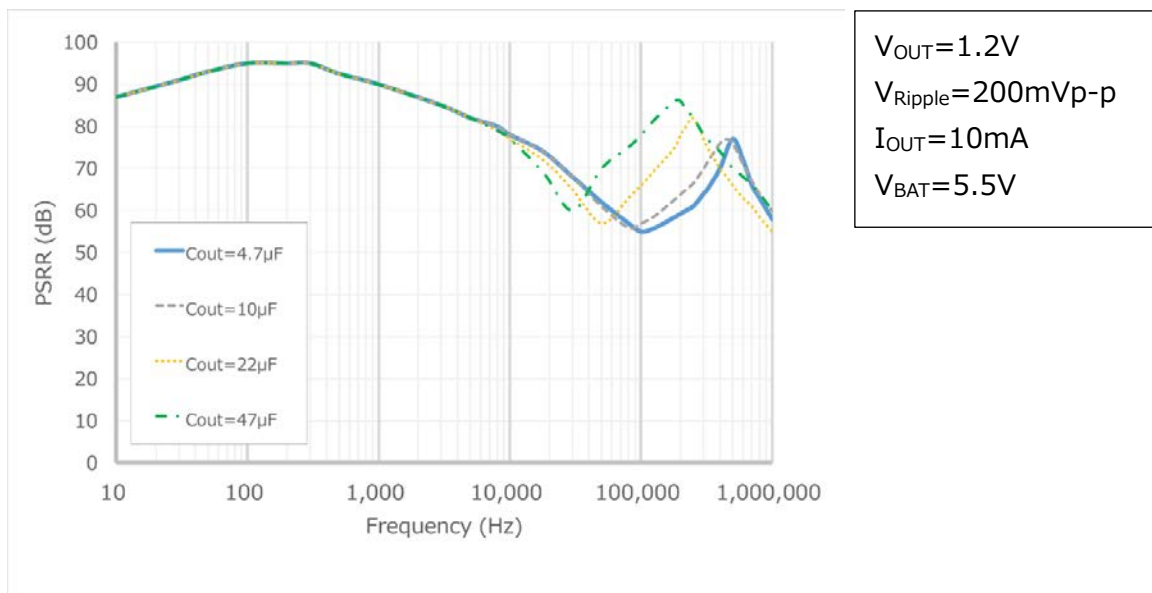

Figure 3.5 PSRR-frequency characteristics

The PSRR, also known as a ripple rejection ratio, indicates the capability of an LDO regulator to suppress variations noise in the input power supply. Expressed in decibels (dB), the greater the PSRR, the better performance. The PSRR varies with the frequency of noise added on the input power supply. At frequencies of noise below 1kHz, the TCR15AG series regulates the output voltage through an internal feedback loop and thus reach a very high PSRR performance about 90dB. The TCR15AG series also provides a high PSRR from 75 to 80dB at 10kHz. As the frequency increases, the PSRR decreases. The amount of decrease in the PSRR is determined by the frequency characteristics of an error amplifier used in the internal feedback loop of an LDO regulator. The TCR15AG series has a PSRR about 55dB even at 100kHz with the recommended output capacitor (C_{OUT}) value of 4.7µF. This shows that the high-performance error amplifier used in the TCR15AG series is effective in increasing the PSRR. Figure 3.5 shows PSRR-vs-frequency characteristics for different C_{OUT} values. As C_{OUT} increases, the PSRR begins to decline at lower frequencies. On the other hand, a larger C_{OUT} provides a higher PSRR in the high-frequency region due to the positive effect of larger capacitance. For example, at 100kHz, the TCR15AG series has a PSRR of about 55 dB when $C_{OUT}=4.7\mu\text{F}$ whereas it provides a PSRR of about 65dB, 10dB higher, when $C_{OUT}=22\mu\text{F}$.

This improvement of the PSRR is the effect of a larger output capacitance rather than the ripple rejection performance of the LDO regulator. In a higher-frequency region, the PSRR declines again. The points of inflection on the PSRR curve depend on the value of the output capacitor (C_{OUT}), the frequency characteristics of the capacitance, resistance, and inductance of the output capacitor, and distributed parameters of a board. For noise-sensitive applications that operate at a frequency of 10kHz or higher, it is recommended to test with different types and values of capacitors and select the good one.

3.3. Achieving a fast high-load transient response

In order to achieve a low dropout voltage and a high current-drive capability of 1.5A, the TCR15AG series drives an internal MOSFET with a supply voltage from the VBIAS pin separate from VIN. With a low dropout voltage performance, the TCR15AG series can regulate a low output voltage. LDO regulators with a low output voltage are commonly used for SoCs, memories, and other high-speed digital signal processing applications, which is typically up and down rapid change in power consumption. Obviously, in the face of sudden changes in the load current, LDO regulators must supply a precisely regulated output voltage to the load. Therefore, a load transient response, which is defined as a change in the regulated output voltage that occurs as a result of a change in the load current, is important.

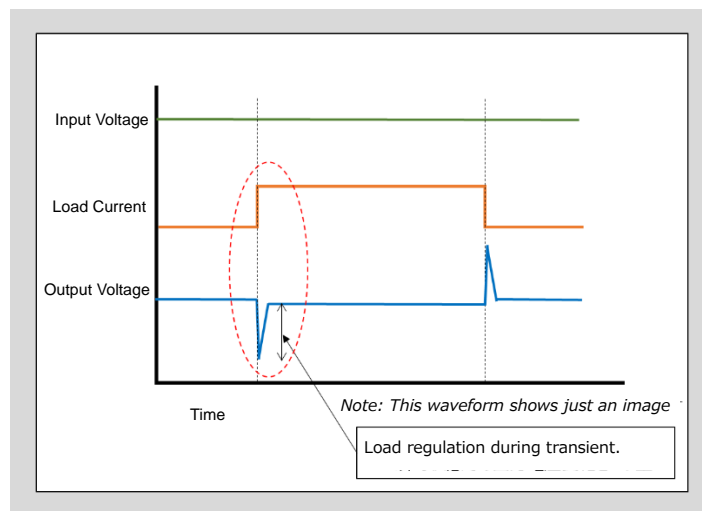

Figure 3.6 Image of a typical load transient response

Figure 3.6 shows an image of a typical load transient response. Generally, as the load current increases, the output capacitor (C_{OUT}) begins to discharge. Then, the LDO regulator starts voltage control via an internal feedback loop to maintain a regulated output voltage. However, in the event of a sudden change in the load current, C_{OUT} is discharged a moment, causing the output voltage to decrease. If the voltage control feedback loop is slow to respond, the output voltage continues decreasing until the feedback loop starts to act its effect to bring the output voltage back to the regulated level. The load transient response is important since a problem occurs if the output voltage drops below the minimum operating voltage required by the load. In the event of an excessive voltage drop, the load suffers a loss in performance or possibly a shutdown. Such an event may lead

adversely lacking the operation or performance of the entire system. The fast load transient response and the ability to provide a low output voltage make the TCR15AG series suits a power supply for high-speed digital signal processing applications, including SoCs and the digital core (control) of CMOS image sensors. Figure 3.7 shows examples of load transient response waveforms of the TCR15AG12 ($V_{OUT}=1.2V$).

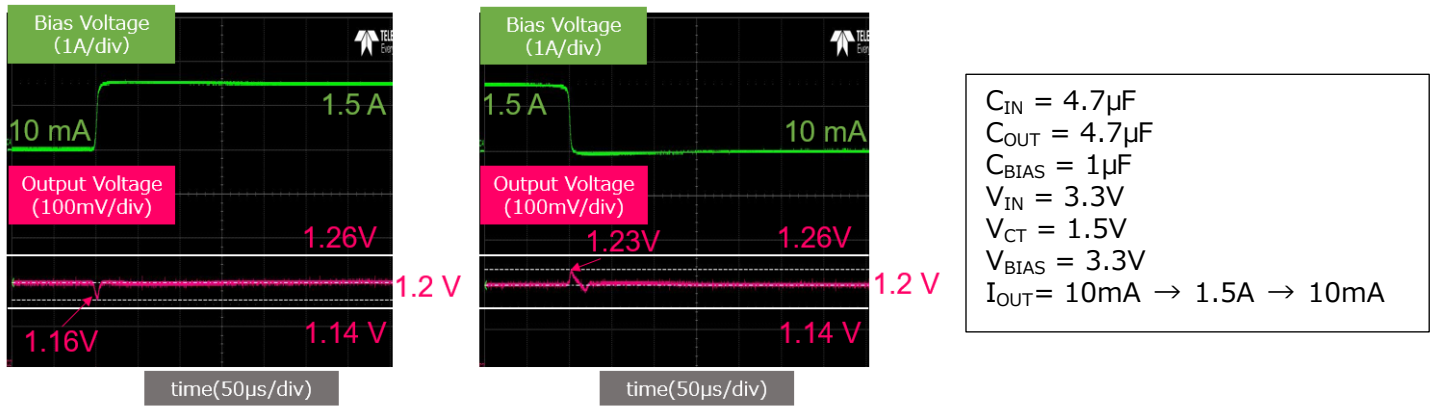

Figure 3.7 Example of load transient response waveforms

The left-side image shows the output voltage waveform in response to a change in the load current from 10mA to 1.5A. The right-side image shows the waveform in response to a load current change from 1.5 A to 10 mA. For example, the load current changes rapidly in case of the digital core of a CMOS image sensor transitions from an idle state to an active mode or in case of a memory device performs a burst transfer at high speed. The load transient responses of the TCR15AG series shown in Figure 3.3.2 are the results of measurement under more severe conditions than these cases. As described in the previous section, a high-performance error amplifier integrated in the TCR15AG series makes it possible to maintain a regulated output voltage even in the event of sudden change in the load current. In fact, LDO regulators are seldom exposed to load current changes as rapid as those shown in Figure 3.7. Therefore, the TCR15AG series provides a sufficient design margin even for systems sensitive to power supply swing.

4. Output voltage

The TCR15AG series has 46 LDO regulators with different fixed output voltage options from 0.65V to 3.6V.

The LDO regulator output should be placed close to the load on a Printed Circuit Board (PCB). Otherwise, the impedance of the PCB wiring causes a voltage drop, making the load's input voltage lower than the LDO output voltage. If the LDO output voltage is equal to the load's input voltage requirement, the load's input voltage might fall below the operation range because of the voltage drop. The load, i.e., an IC or a module, has a proper input voltage range to ensure proper operation. Generally, the IC (or module) performance can be improved by increasing the input voltage so that it is closer to the upper limit, but power consumption is increased accordingly. Conversely, power consumption can be reduced by decreasing the input voltage to the IC (or module), but the performance degradation may happen.

Even if the input voltage to the load (IC or module) is within its specification range, an actual application may not work properly caused by poor input voltage. In that case, it is necessary to adjust power supply specifications so that the LDO output voltage becomes slightly higher than the minimum input voltage of the load.

The TCR15AG series provides fixed-voltage LDO regulators selectable in 0.05V increments at voltages lower than 1.4V and around the standard power supply voltages such as 1.8V and 3.3V. Therefore, the TCR15AG series offers you to select an LDO regulator with an output voltage that best matches your power supply requirement.

In the case of the TCR15AGADJ adjustable-voltage LDO regulator, the output voltage is adjusted by outside resistor divider. This means that the output voltage accuracy depends on the accuracy of the internal reference voltage (V_{ADJ}) as well as the accuracy of outside resistors. In the case of fixed-voltage LDO regulators, you need to consider only the output voltage accuracy specified in a datasheet. The following considers the output voltage accuracy of the TCR15AGADJ (Adjustable-voltage) and the TCR15AG18 (Fixed-voltage) LDO regulators at a typical output voltage of 1.8V.

Adjustable-output LDO regulator

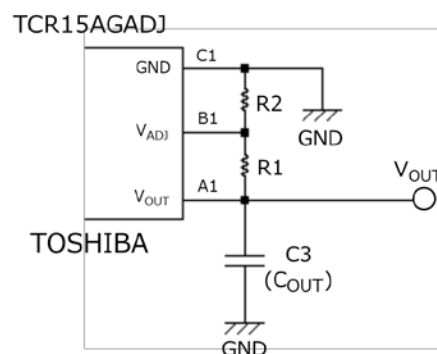

Figure 4.1 Example of an output circuit for the adjustable-output TCR15AGADJ

The output voltage (V_{OUT}) is calculated as follow:

$$V_{OUT} = V_{ADJ} \times \left(1 + \frac{R1}{R2} \right)$$

where, R1 and R2 are voltage divider resistor values. Suppose that R1=48k Ω and R2=24k Ω , which are the recommended values for a V_{OUT} of 1.8V.

The TCR15AGADJ provides the maximum output voltage when its internal reference voltage (V_{ADJ}) is at the maximum (0.612V), R1 has the maximum value within the register's specification, and R2 has the minimum value within the register's specification. If you select commonly used high-accuracy resistors with 0.5% tolerance, then R1 is 48.24k Ω maximum, and R2 is 23.88k Ω minimum. Substituting these values into the above equation, the maximum V_{OUT} value is calculated to be 1.848V, which is 2.7% higher than the typical V_{OUT} value of 1.8V.

On the other hand, the TCR15AGADJ provides the minimum output voltage when V_{ADJ} is at the minimum (0.588V), R1 has the minimum value (47.76k Ω), and R2 has the maximum value (24.12k Ω). So the minimum V_{OUT} value is calculated to be 1.752V, which is 2.7% lower than the typical V_{OUT} value of 1.8V.

Fixed-output LDO regulator

The TCR15AG18 has an output voltage accuracy of $\pm 1\%$. As described before, the TCR15AGADJ is $\pm 2.7\%$ even when resistors with 0.5% tolerance are used, while the fixed-output LDO regulator provides an accuracy of $\pm 1\%$. As shown by these examples, a fixed-output LDO regulator suits the designing of a power supply when high-accuracy output voltage regulation is required.

In addition, compared with adjustable-output LDO regulators, fixed-output LDO regulators help reduce the parts count and the board area since they do not require outside resistors of voltage divider.

The typical output voltage and its accuracy are specified under the test conditions given in a datasheet. It should be noted that the output voltage may drop if the output current is higher than the actual applications.

5. Design considerations

- External capacitors

A ceramic capacitor can be used as an output capacitor for the TCR15AGADJ. However, the characteristics of some ceramic capacitors have very large temperature dependence. An output capacitor should be carefully selected, taking the environmental conditions into account. It is also recommended to use a ceramic capacitor with an equivalent series resistance (ESR) of 1.0Ω or less. To ensure stable operation, use an input capacitor of $4.7\mu\text{F}$ or greater, a bias capacitor of $1.0\mu\text{F}$ or greater, and an output capacitor of $4.7\mu\text{F}$ or greater.

- Board assembly

Provide as large a GND plane as possible to reduce wire impedance. Voltage overshoot and undershoot may happen depending on transient responses of the input and output voltage and current, a PCB layout, and internal parasitic of an IC.

- Power dissipation

Designing PCB, the IC temperature remains well below the maximum rated temperature during operation even at the maximum power dissipation point. For PCB design, ambient temperature, input voltage, and output current, and other environmental conditions should also be considered.

- Overcurrent protection and thermal shutdown

The TCR15AG series has feedback loops for overcurrent protection and thermal shutdown. It should be noted that these features are not intended to guarantee that the device is kept below the absolute maximum ratings. Exposure to conditions exceeding the absolute maximum ratings might adversely affect the functionality and reliability of the device. The device might be permanently damaged if the output and GND pins of the TCR15AGADJ become partially short-circuited.

Apply the above design considerations and derate the absolute maximum rated values as described in the Toshiba Semiconductor Reliability Handbook to ensure that none of the absolute maximum ratings will be exceeded under any circumstances. It is recommended to add fail-safe and other safety features to an application system.

6. Product overview

6.1. TCR15AG (fixed voltage type)

6.1.1. Overview

The TCR15AG series consists of single-fixed-output LDO regulators with a control pin fabricated using a CMOS process, which feature an ultra-low dropout, fast load transient response, and inrush current limiting.

The TCR15AG series offers 46 LDO regulators with a fixed voltage of 0.65V to 3.6V and a maximum output current of 1.5A and provides overcurrent protection, thermal shutdown, inrush current limiting, undervoltage lockout, and auto output discharge.

The TCR15AG series is housed in the ultra-small WCSP6F package (0.8mm x 1.2mm (typical), t: 0.33mm (maximum)). Since small ceramic capacitors can be used as input and output capacitors, the TCR15AG series is ideal for applications that require high-density board assembly such as mobile devices.

- Ultra-small package: WCSP6F (0.8mm x 1.2mm typical; t: 0.33mm maximum)
- Wide range of output voltage ($V_{OUT} = 0.65V$ to $3.6V$)
- Fast load transient response: $-100 / +115mV$ (typical) at $0.01A \Leftrightarrow 1.5A$, $C_{OUT} = 4.7\mu F$
- High Power Supply Rejection Ratio : PSRR = 95dB (typical) at 1kHz
- Overcurrent protection
- Thermal shutdown
- Auto output discharge function
- Inrush current limiting
- Output-voltage soft-start
- Undervoltage lockout threshold: 0.5V (typical)

6.1.2. External view and pin assignment

External view and marking

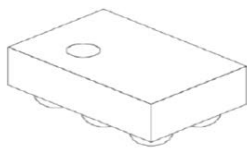

Bottom View

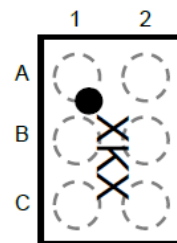

Pin assignment

	1	2
A	V_{OUT}	V_{IN}
B	SENSE	CONTROL
C	GND	V_{BIAS}

Figure 6.1 External view, marking, and pin assignment

Table 6.1 TCR15AG (fixed voltage type) lineup

Part Number	V _{OUT} (V) (typ.)	Marking	Part Number	V _{OUT} (V) (typ.)	Marking
TCR15AG065	0.65	0KA	TCR15AG20	2.0	2K0
TCR15AG07	0.7	0K7	TCR15AG21	2.1	2K1
TCR15AG075	0.75	0KB	TCR15AG22	2.2	2K2
TCR15AG08	0.8	0K8	TCR15AG23	2.3	2K3
TCR15AG085	0.85	0KC	TCR15AG24	2.4	2K4
TCR15AG09	0.9	0K9	TCR15AG25	2.5	2K5
TCR15AG095	0.95	0KF	TCR15AG26	2.6	2K6
TCR15AG10	1.0	1K0	TCR15AG27	2.7	2K7
TCR15AG105	1.05	0KH	TCR15AG275	2.75	0KP
TCR15AG11	1.1	1K1	TCR15AG28	2.8	2K8
TCR15AG115	1.15	0KJ	TCR15AG285	2.85	0KR
TCR15AG12	1.2	1K2	TCR15AG29	2.9	2K9
TCR15AG125	1.25	0KK	TCR15AG295	2.95	0KT
TCR15AG13	1.3	1K3	TCR15AG30	3.0	3K0
TCR15AG135	1.35	0KL	TCR15AG305	3.05	0KU
TCR15AG14	1.4	1K4	TCR15AG31	3.1	3K1
TCR15AG15	1.5	1K5	TCR15AG32	3.2	3K2
TCR15AG16	1.6	1K6	TCR15AG325	3.25	0KW
TCR15AG17	1.7	1K7	TCR15AG33	3.3	3K3
TCR15AG175	1.75	0KM	TCR15AG335	3.35	0KX
TCR15AG18	1.8	1K8	TCR15AG34	3.4	3K4
TCR15AG185	1.85	0KN	TCR15AG35	3.5	3K5
TCR15AG19	1.9	1K9	TCR15AG36	3.6	3K6

6.1.3. Internal block diagram

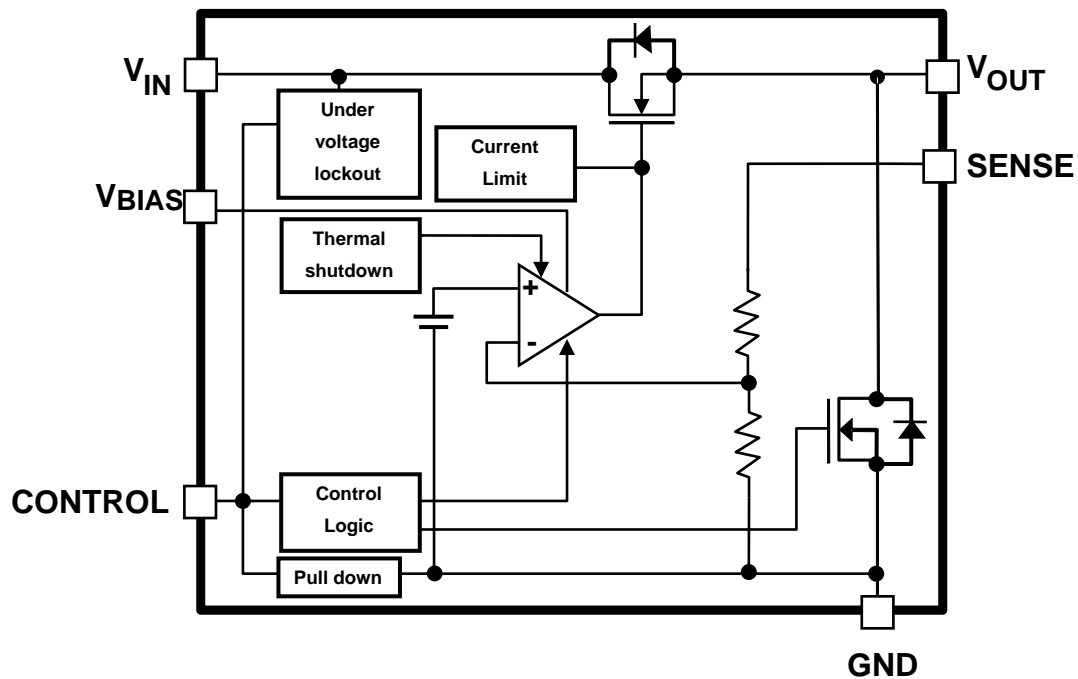

Figure 6.2 Internal block diagram

6.1.4. Pin description

Table 6.2 Pins of the TCR15AG (fixed voltage type)

Pin	Name	Description
A1	V_{OUT}	Output. For stable operation, add an output capacitor of 4.7 μ F or greater.
B1	SENSE	SENSE pin. Connect the SENSE pin to the V_{OUT} pin with the shortest possible wire to avoid the effect of noise.
A2	V_{IN}	Power supply input. For stable operation, add an input capacitor of 4.7 μ F or greater
B2	CONTROL	Output on/off control pin. A High on this input turns on the output. A Low on this input turns off the output. The CONTROL pin is internally connected to GND via a pulldown resistor.
C1	GND	Ground
C2	V_{BIAS}	Bias power supply pin. For stable operation, add a bias capacitor of 1.0 μ F or greater (with an ESR of 1.0 Ω or less).

Terms of Use

This terms of use is made between Toshiba Electronic Devices and Storage Corporation ("We") and customers who use documents and data that are consulted to design electronics applications on which our semiconductor devices are mounted ("this Reference Design"). Customers shall comply with this terms of use. Please note that it is assumed that customers agree to any and all this terms of use if customers download this Reference Design. We may, at its sole and exclusive discretion, change, alter, modify, add, and/or remove any part of this terms of use at any time without any prior notice. We may terminate this terms of use at any time and for any reason. Upon termination of this terms of use, customers shall destroy this Reference Design. In the event of any breach thereof by customers, customers shall destroy this Reference Design, and furnish us a written confirmation to prove such destruction.

1. Restrictions on usage

1. This Reference Design is provided solely as reference data for designing electronics applications. Customers shall not use this Reference Design for any other purpose, including without limitation, verification of reliability.
2. This Reference Design is for customer's own use and not for sale, lease or other transfer.
3. Customers shall not use this Reference Design for evaluation in high or low temperature, high humidity, or high electromagnetic environments.
4. This Reference Design shall not be used for or incorporated into any products or systems whose manufacture, use, or sale is prohibited under any applicable laws or regulations.

2. Limitations

1. We reserve the right to make changes to this Reference Design without notice.
2. This Reference Design should be treated as a reference only. We are not responsible for any incorrect or incomplete data and information.
3. Semiconductor devices can malfunction or fail. When designing electronics applications by referring to this Reference Design, customers are responsible for complying with safety standards and for providing adequate designs and safeguards for their hardware, software and systems which minimize risk and avoid situations in which a malfunction or failure of semiconductor devices could cause loss of human life, bodily injury or damage to property, including data loss or corruption. Customers must also refer to and comply with the latest versions of all relevant our information, including without limitation, specifications, data sheets and application notes for semiconductor devices, as well as the precautions and conditions set forth in the "Semiconductor Reliability Handbook".
4. When designing electronics applications by referring to this Reference Design, customers must evaluate the whole system adequately. Customers are solely responsible for all aspects of their own product design or applications. WE ASSUME NO LIABILITY FOR CUSTOMERS' PRODUCT DESIGN OR APPLICATIONS.
5. No responsibility is assumed by us for any infringement of patents or any other intellectual property rights of third parties that may result from the use of this Reference Design. No license to any intellectual property right is granted by this terms of use, whether express or implied, by estoppel or otherwise.
6. THIS REFERENCE DESIGN IS PROVIDED "AS IS". WE (a) ASSUME NO LIABILITY WHATSOEVER, INCLUDING WITHOUT LIMITATION, INDIRECT, CONSEQUENTIAL, SPECIAL, OR INCIDENTAL DAMAGES OR LOSS, INCLUDING WITHOUT LIMITATION, LOSS OF PROFITS, LOSS OF OPPORTUNITIES, BUSINESS INTERRUPTION AND LOSS OF DATA, AND (b) DISCLAIM ANY AND ALL EXPRESS OR IMPLIED WARRANTIES AND CONDITIONS RELATED TO THIS REFERENCE DESIGN, INCLUDING WARRANTIES OR CONDITIONS OF MERCHANTABILITY, FITNESS FOR A PARTICULAR PURPOSE, ACCURACY OF INFORMATION, OR NONINFRINGEMENT.

3. Export Control

Customers shall not use or otherwise make available this Reference Design for any military purposes, including without limitation, for the design, development, use, stockpiling or manufacturing of nuclear, chemical, or biological weapons or missile technology products (mass destruction weapons). This Reference Design may be controlled under the applicable export laws and regulations including, without limitation, the Japanese Foreign Exchange and Foreign Trade Law and the U.S. Export Administration Regulations. Export and re-export of this Reference Design are strictly prohibited except in compliance with all applicable export laws and regulations.

4. Governing Laws

This terms of use shall be governed and construed by laws of Japan.