

Application Circuit of Low Noise Op-Amp TC75S67TU for Pulse Sensor

Design guide

RD159-DGUIDE-01

Overview

This Design Guide describes the design of pulse sensors using a low-noise Op-amp TC75S67TU. Pulse rate is one of the important parameters in determining health status. This guide describes how to design pulse sensors that use TC75S67TU to detect the increase or decrease of vascular flow by measuring the reflected light of the irradiated light on the living body.

TOSHIBA ELECTRONIC DEVICES & STORAGE CORPORATION

Contents

1. Introduction	3
2. Circuit design	4
2.1. Pulse sensor	4
2.2. Pulse sensor specifications.....	6
2.3. Circuit design of the pulse sensor.....	6
2.3.1. Sensor circuit (flexible board).....	7
2.3.2. Amplifier circuit (rigid board)	9
3. Board design	12
3.1. Example of flexible board pattern.....	12
3.2. Example of rigid board pattern.....	13
3.3. Precautions for board design.....	14
4. Product Overview	16
4.1. TC75S67TU.....	16
4.2. Pin description.....	17

1. Introduction

Even today in the digital age, operational amplifiers (below, Op-amp) are used in various situations, especially a particularly important application is for a variety of sensors.

There are various types of information that can be obtained from nature, such as sound and light, and there are various types of sensor elements. In general, the output signal from the sensor element is very small and is difficult to handle so in most cases the signal from sensors are amplified and processed by Op-amp. In addition to amplification, Op-amps are used for filters, I-V converters, and other applications in various sensors. Without Op-amps, it is not an overstatement to say that most modern electronic devices cannot be realized.

Noise characteristics are important in the application of these sensors. If the Op-amp itself is noisy, the critical sensor signal may be hidden by the noise so the result is a decrease in detection sensitivity or erroneous detection and the desired sensing performance may not be obtained. For this reason, Op-amps used in such applications are required to have low noise levels.

To meet these requirements, Toshiba has introduced an Op-amp TC75S67TU with low noise levels of 6 nV/ $\sqrt{\text{Hz}}$ (f=1 kHz, GV=40 dB, normal).

This Design Guide describes the design of pulse sensors using TC75S67TU. Refer to the datasheet for more information on the TC75S67TU.

To download the datasheet for TC75S67TU →

[Click Here](#)

2. Circuit design

This section describes key point of the circuit design for the pulse sensor.

2.1. Pulse sensor

Pulses are caused by repeated increases and decreases in blood flow delivered by the heart's beats. Oxygenated hemoglobin in blood absorbs light. When a living body is irradiated with light, the amount of light absorption changes as the blood flow increases and decreases, and the amount of light reflection also changes. A graph of the change in the amount of reflected light in time series is called a pulse wave. This guide describes an example of an application circuit for a reflective pulse sensor with photodiode, which detects the amount of reflected light and measures a pulse rate.

The pulse sensor described in this guide consists of two circuit boards, one is a flexible board for wearable applications to the human body which has OSRAM Co., Ltd.'s light sensor SFH7051 (Fig. 2.1, Fig. 2.2) with LEDs and photodiode in one package and Toshiba's Op-amp TC75S67TU. The output current of the SFH7051 photodiode is converted to a voltage by a TC75S67TU, and the voltage is output to another circuit board. The other board is a conventional rigid board. The output signal of the flexible board is amplified by 100x (40dB) non-inverting amplifier composed of TC75S67TU and output to a microcontroller.

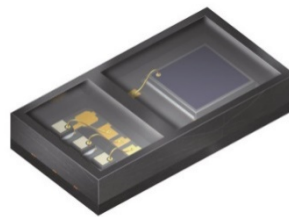

Fig. 2.1 Light Sensor (SFH7051 manufactured by OSRAM Corporation)

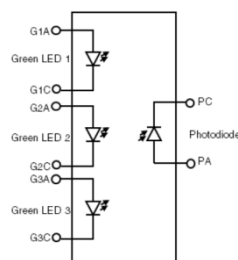

Fig. 2.2 Light Sensor Internal Structure

LEDs with built-in SFH7051 emit green light at 530nm (typical). Oxygenated hemoglobin has high absorption rate for Green light, which makes it easier to measure the increase or decrease in the amount of reflected light. It is also less susceptible to ambient light disturbances when used in environments such as outdoor in clear weather or indoor fluorescent lights. In addition, it is necessary to pay attention to the effects of individual differences in blood vessels and physical condition.

This guide uses the Arduino that allows the microcontroller to control the operation of the entire pulse sensor and display the measurement results on PC. If you can prepare the software, you can use other microcontrollers, but please check the operation sufficiently.

2.2. Pulse sensor specifications

Table 2.1 shows the specifications of this pulse sensor.

Table 2.1 Specifications of the pulse sensor

Item	Specifications
I/F	Arduino connections
Control method	Control from Arduino and Shield connected PCs
Power supply voltage	5 V supplied from Arduino and Shield board
Onboard pulse sensor	OSRAM Co., Ltd.'s SFH7051
Emission wavelength	530 nm
On-board Op-amp	TC75S67TU manufactured by Toshiba Devices & Storage Co., Ltd.

2.3. Circuit design of the pulse sensor

Fig. 2.3 shows an overview of the pulse sensor. This sensor consists of a sensor circuit section (flexible board) on the left side and an amplifier circuit section (rigid board) on the right side. This section explains the circuit design for each board.

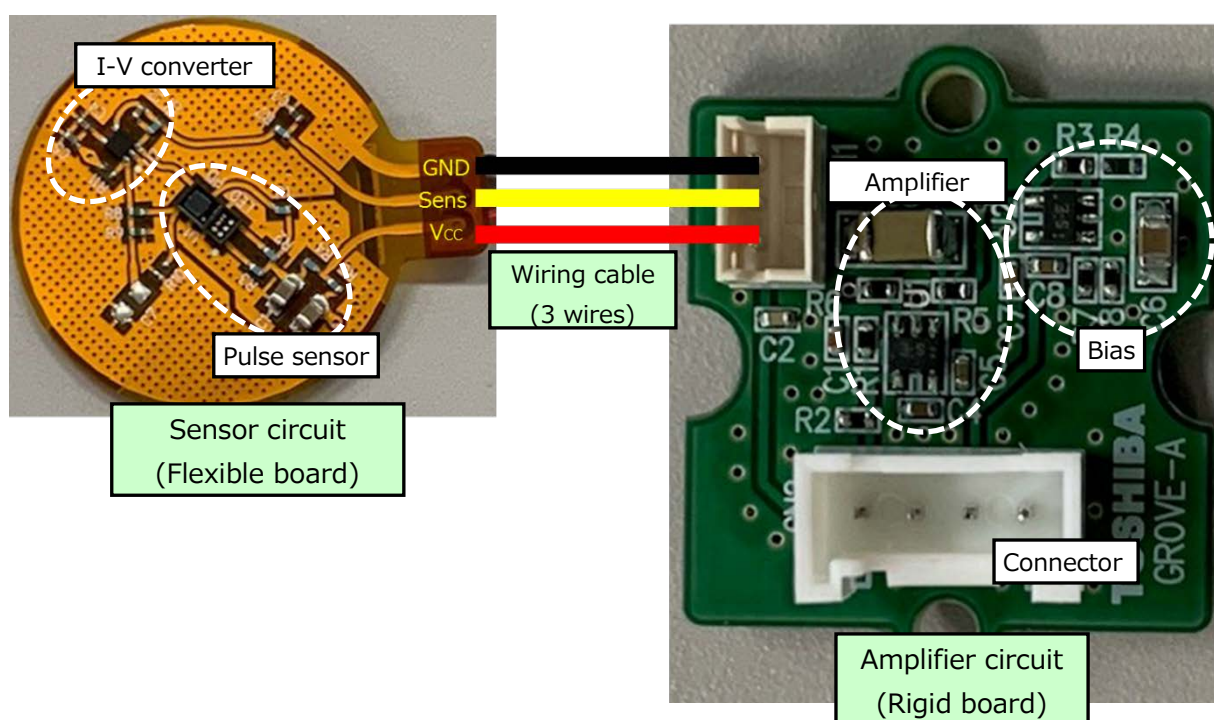

Fig. 2.3 Overview of the pulse sensor

2.3.1. Sensor circuit (flexible board)

The circuit of the pulse sensor is shown in Fig. 2.4.

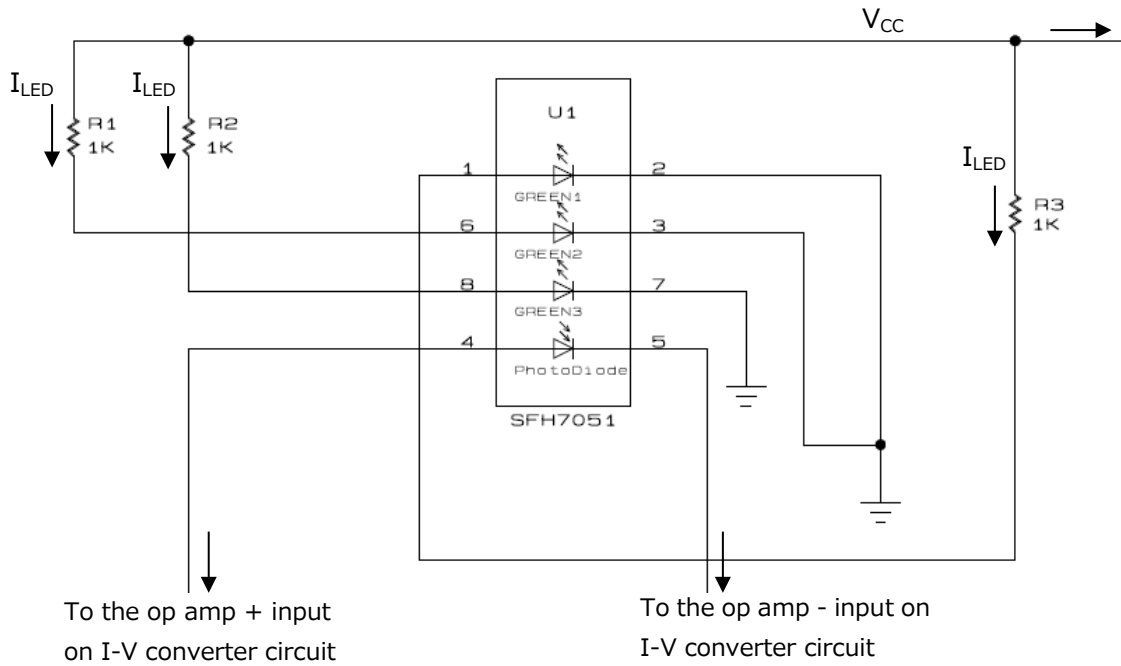

Fig. 2.4 Pulse Sensor

In this sensor, 3 green LEDs with built-in SFH7051 are connected to a 5 V power supply through a current limiting resistor and turn on. The I_{LED} of current flowing through LEDs is calculated by the following equation (2.1).

$$I_{LED} = \frac{V_{CC} - V_{F(LED)}}{R_1} \quad \dots (2.1)$$

- V_{CC} : Power supply voltage
- $V_{F(LED)}$: Forward voltage of LEDs,
- R_1 : 1 k Ω (current limiting resistor)

This sensor has a V_{CC} of 5 V, a $V_{F(LED)}$ of 3.2 V, and an R_1 of 1 k Ω . Therefore, I_{LED} is 1.8 mA. Since $R_1=R_2=R_3$, all LEDs have the same current.

Light from LEDs reflected back in the body when it comes into contact with the human body is detected by a photodiode built in the same package.

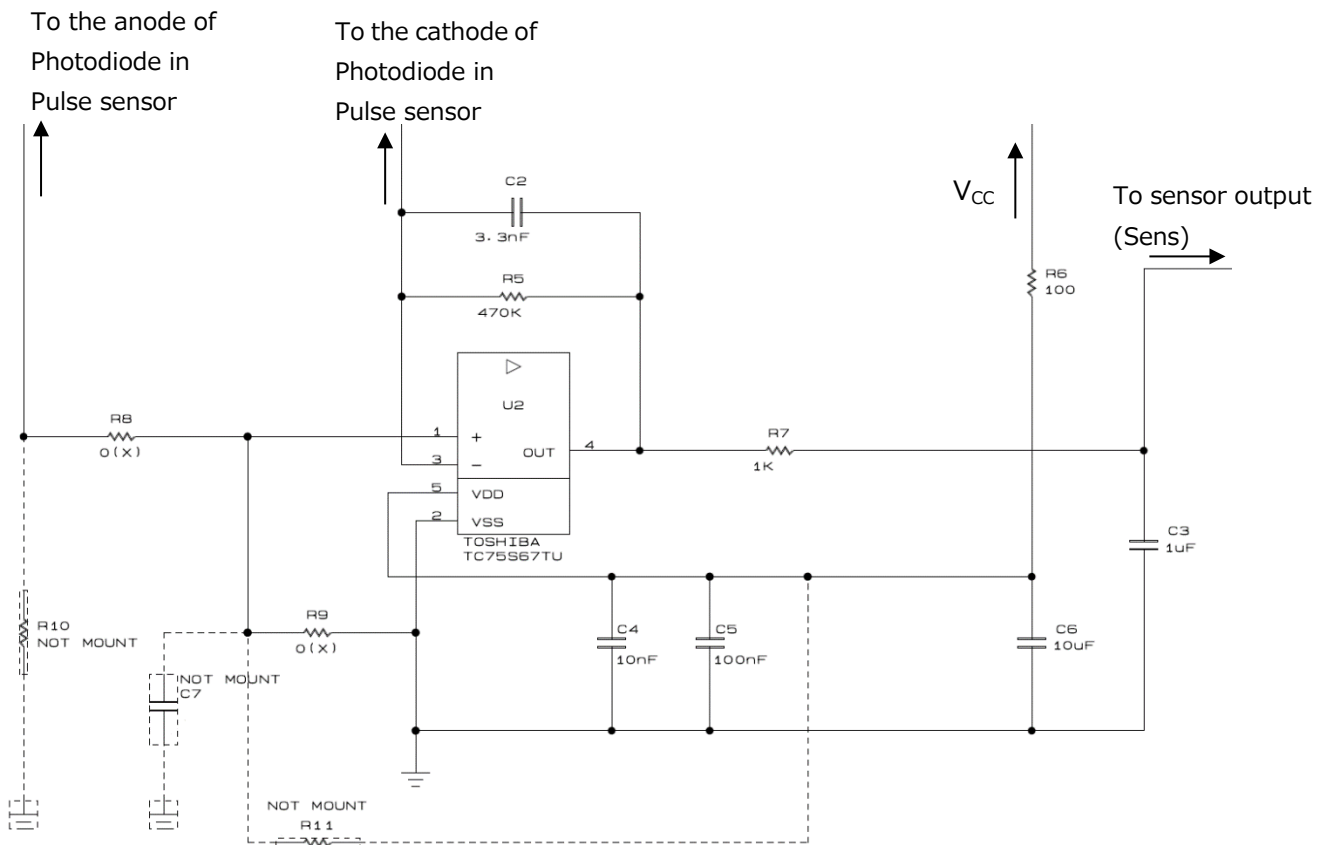

Fig. 2.5 I-V converter circuit

Fig. 2.5 shows a circuit that uses an Op-amp to convert the output current of a photodiode into a voltage. The output current of the photodiode is converted to a voltage by R5. The R5 and C2 configure a low-pass filter (LPF), and R7 and C3 configure LPF at the output also. These LPFs reduce the influence of noise such as disturbance light during measurement.

Since the normal human pulse rate is about 60 times per minute (about 1 Hz), the LPF band width can be narrowed to a cutoff frequency about 50Hz or less. However, the LPF band width may be widened so that high-harmonic can be obtained in order to detect the waveform of the pulse wave correctly. This sensor sets the cut-off frequencies $f_{c1}=103$ Hz (R5 and C2) and $f_{c2}=159$ Hz (R7 and C3), respectively.

If the bandwidth is widened, use a housing, etc. to reduce the influence of disturbance light. The formula for each cut-off frequency is as follows:

$$f_{c1} = \frac{1}{2 \times \pi \times R5 \times C2} = \frac{1}{2 \times \pi \times 470 \times 10^3 \times 3.3 \times 10^{-9}} \cong 103 \text{ Hz} \quad \dots (2.2)$$

$$R5: 470 \text{ k}\Omega, C2: 3.3 \text{ nF}$$

$$f_{c2} = \frac{1}{2 \times \pi \times R7 \times C3} = \frac{1}{2 \times \pi \times 1 \times 10^3 \times 1 \times 10^{-6}} \cong 159 \text{ Hz} \quad \dots (2.3)$$

$$R7: 1 \text{ k}\Omega, C3: 1 \text{ }\mu\text{F}$$

2.3.2. Amplifier circuit (rigid board)

The sensor output signals converted to voltage are transmitted to the amplifier circuits on the rigid board through the cables and the connector CN1. Fig. 2.6 shows the input and amplifier circuits of the amplifier circuit board.

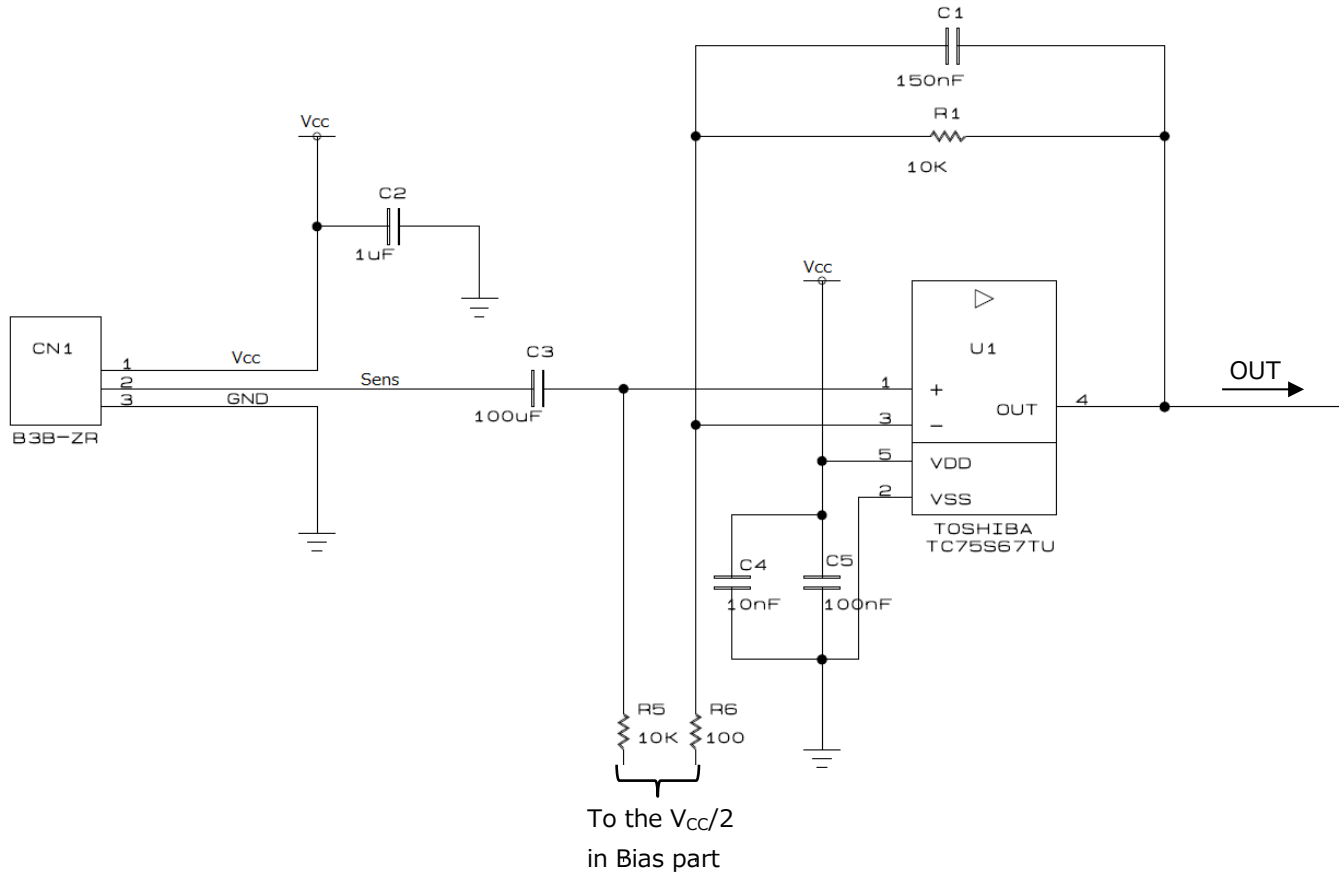

Fig. 2.6 Amplifier circuit

The high pass filter (HPF) consisting of C3 and R5 removes the DC-component of the sensor signal, inputs the sensor signal to the Op-amp U1 (TC75S67TU), and amplifies the sensor signal in a non-inverting manner. Again, the LPF consisting of the feedback resistor R1 and C1 connected in parallel removes unnecessary components.

The HPF cut-off frequency f_{c3} , the Op-amp DC gain G_v , and the LPF cut-off frequency f_{c4} are calculated by the following formulas. The amplification factor is determined from the output level of the sensor.

$$f_{c3} = \frac{1}{2 \times \pi \times R5 \times C3} = \frac{1}{2 \times \pi \times 10 \times 10^3 \times 100 \times 10^{-6}} \cong 0.16 \text{ Hz} \quad \dots (2.4)$$

R5: 10 kΩ, C3: 100 μF

$$G_v = \frac{R1 + R6}{R6} = \frac{10 \times 10^3 + 100}{100} = 101 \cong 40 \text{ dB} \quad \dots (2.5)$$

R1: 10 kΩ, R6: 100 Ω

$$f_{c4} = \frac{1}{2 \times \pi \times R1 \times C1} = \frac{1}{2 \times \pi \times 10 \times 10^3 \times 0.15 \times 10^{-6}} \cong 106 \text{ Hz} \quad \dots (2.6)$$

R1: 10 kΩ, C1: 0.15 μF

Fig. 2.7 shows the midpoint voltage ($V_{CC}/2$) that is the DC bias of the Op-amp U1 (TC75S67TU) described in Fig. 2.6.

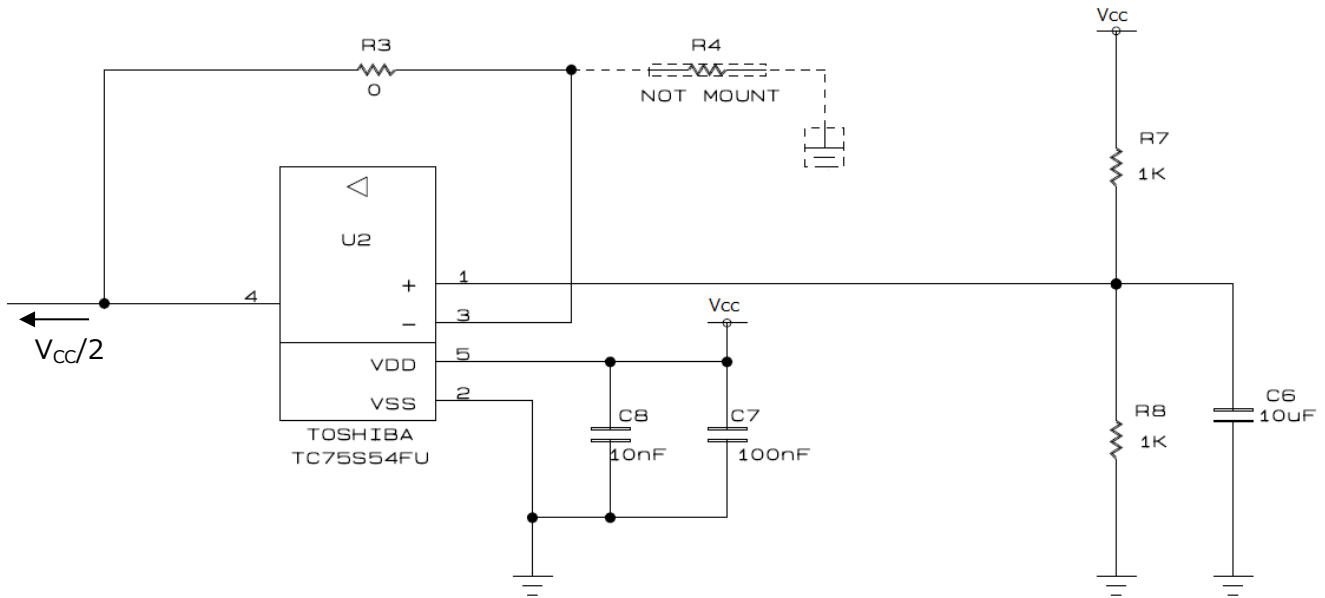

Fig. 2.7 Bias circuit

Op-amp U2 (TC75S54FU) is used as a voltage follower (R3: 0 Ω, R4: Not mount on the circuit). Since voltage follower operation of TC75S67TU is not guaranteed, TC75S54FU is used.

A midpoint voltage ($V_{CC}/2$) obtained by dividing the power supply voltage by resistors R7: 1 kΩ and R8: 1 kΩ is connected to the non-inverting input of U2. The Op-amp output by the voltage follower and the inverting input of U1 is biased. This causes the output signal of U1 to amplify with reference to the midpoint voltage.

Two types of bypass capacitors, 10 nF and 100 nF, are connected in parallel to the power supply of each Op-amp. This is to effectively eliminate power supply noises in a wide frequency range by lowering impedance of a 10 nF capacitor in the high frequency range of about 1 MHz or more, and a 100 nF capacitor in the low frequency range.

Fig. 2.8 shows the circuit diagram of the peripheral part of the output connector CN2 to the microcontroller.

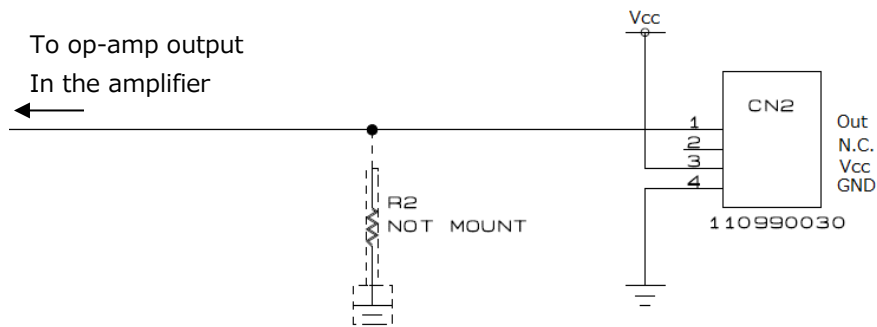

Fig. 2.8 Connector

R2 is "Not Mount" and is not mounted in this sensor. This is a dummy load resistance. If noise to the output or oscillation of the Op-amp is concern, mount a resister of about 10 k Ω .

3. Board design

This section describes the key points of the board design of the pulse sensor.

3.1. Example of flexible board pattern

This circuit board consists of both front and back surfaces. Fig. 3.1 and Fig. 3.2 show the front surface pattern of the flexible board (component mounting surface) and the back surface pattern of the flexible board respectively. Part of the balloon describes in detail in Section 3.3. Please refer to this section as well.

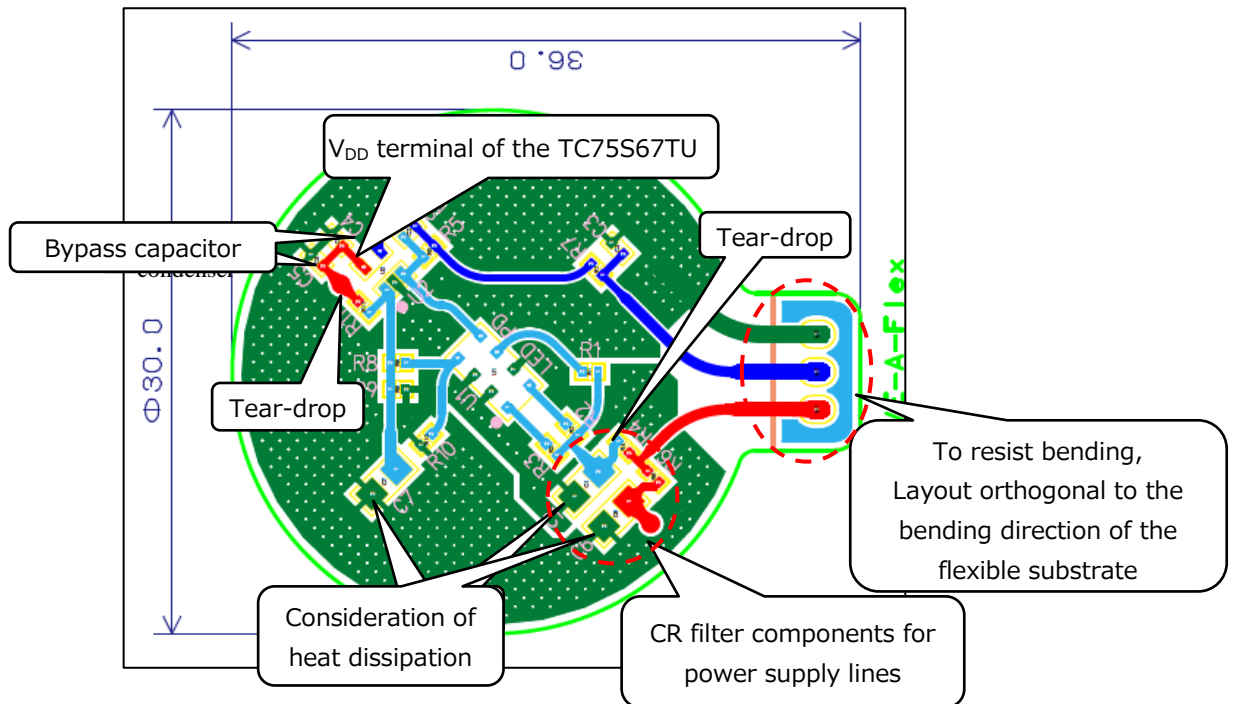

Fig. 3.1 Front surface pattern

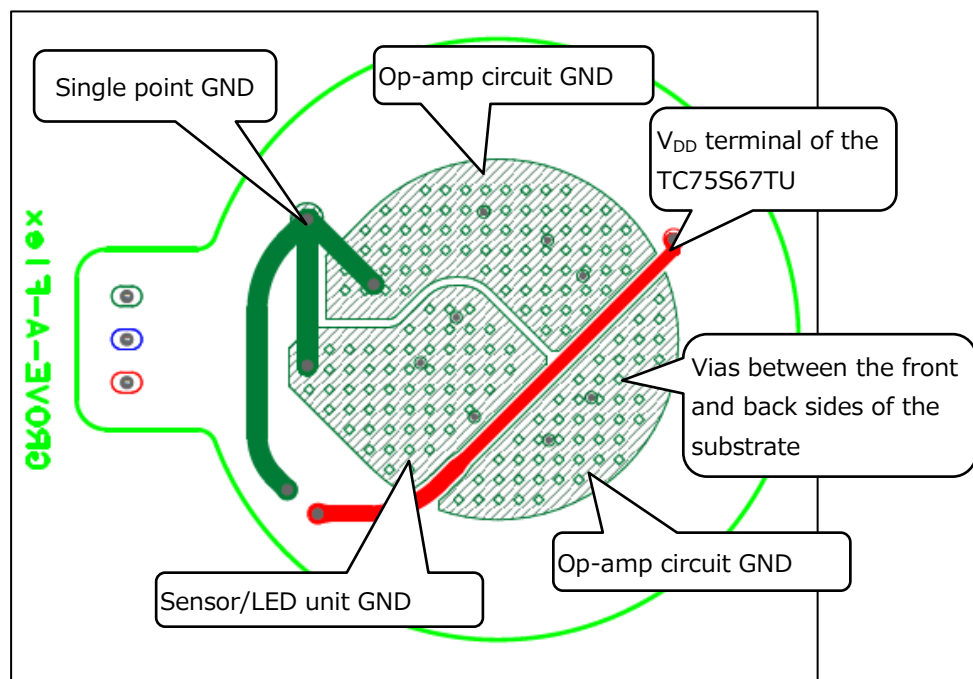

Fig. 3.2 Back surface pattern

3.2. Example of rigid board pattern

This circuit board is also composed of both front and back surfaces. Figure 3.3 and Figure 3.4 show the front surface pattern of the rigid board (component mounting surface) and the back surface pattern of the rigid board respectively. Part of the balloon description is described in detail in Section 3.3. Please refer to this section as well.

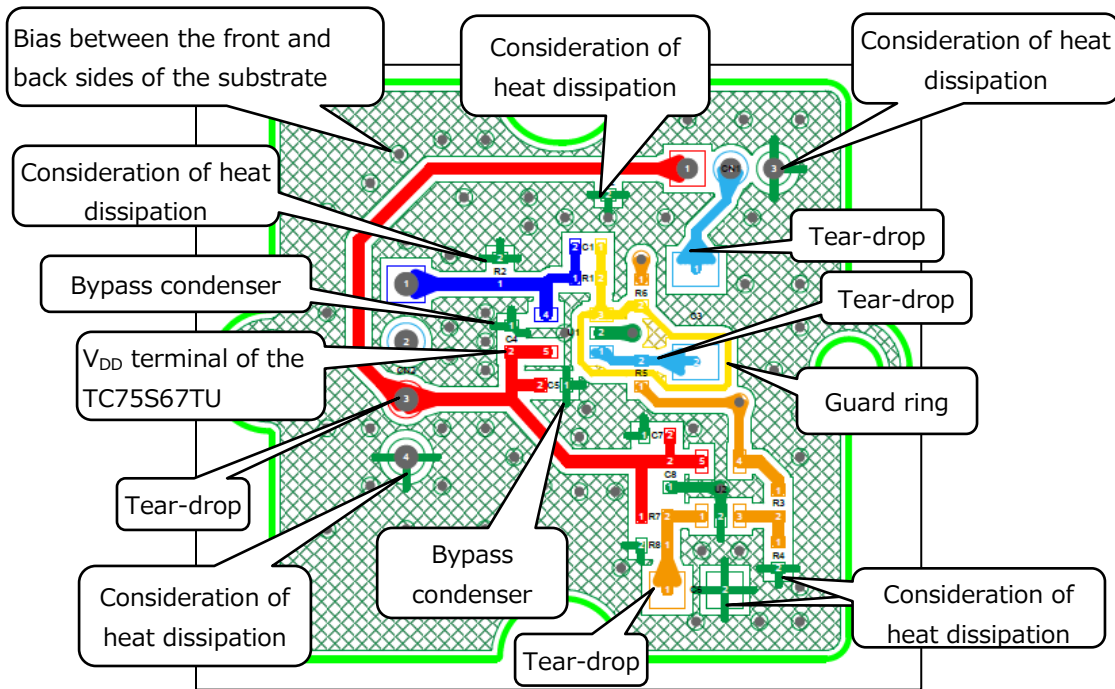

Fig. 3.3 Front surface pattern

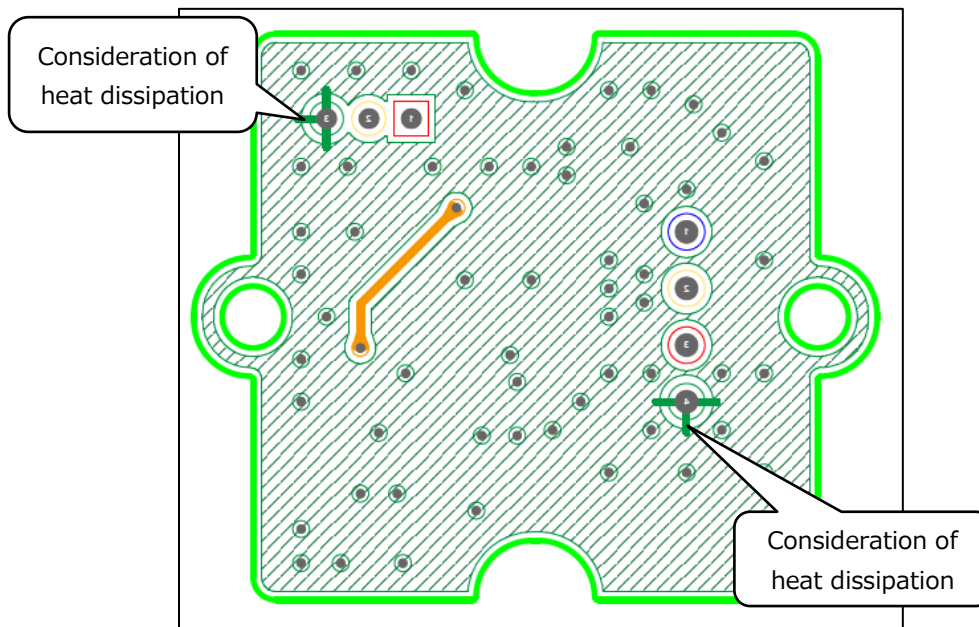

Fig. 3.4 Back surface pattern

3.3. Precautions for board design

- Points of attention specific to flexible substrates (See Fig. 3.1)

Since many devices are mounted on a flexible board, it is recommended that a reinforcing plate be provided between the front and back of the board to increase the strength of the sensor board, and that an overlay sheet be applied instead of a normal resist to prevent cracking during bending. Wire the terminal electrode side of the flexible board so that it is orthogonal to the expected bending direction in order to be resistant to bending.
- Separation of solid GND and one-point GND (see Fig. 3.2)

Separate the output of the Op-amp of the sensor circuit and the GND of the sensor, and form a single point GND. In the example of the pattern, each of them is separated as a solid GND on the back side, and a one-point GND layout is used. This is to prevent superimposition of power supply noise on the output signal of the Op-amp and the sensor/Op-amp circuit.
- Thermal processing (see Fig. 3.1, Fig. 3.3, and Fig. 3.4)

In the pattern example, "Consideration of thermal dissipation" means that the wiring from each pad to the GND is not a solid pattern but is drawn with a cross or T-shaped so that thermal does not escape to a wide solid GND during reflow soldering. This is to prevent the parts from being overheated and deteriorated or damaged due to thermal escape and increased soldering time. Normally, the cross and T-shaped layout portions are buried in solder after soldering and cannot be seen visually.
- Impedance reduction

In the case of a two-layer board, provide as many vias as possible between the front and back sides of the board in order to reduce the impedance. This reduction the impedance of the entire GND, strengthens the solid GND as a reference, prevents a potential difference from being generated in the GND region, and prevents noise from spreading.
- Tear drop shape (see Fig. 3.1 and Fig. 3.3)

In the example of the pattern, the wiring pattern of the connecting portions between the lands and the pads and the wiring is widened to form a tear drop shape. The purpose of this is to prevent the occurrence of current singularities point at the pad and to increase the connection strength between the pad and the wiring.
- Bypass capacitor position (see Fig. 3.1 and Fig. 3.3)

Place the CR filter (LPF) to remove power supply noise near the power supply input to the PCB. In order to remove noise superimposed on the power supply line, connect the two bypass capacitors (0.1 μ F and 0.01 μ F) of the Op-amp as close as possible to the power supply terminal of the Op-amp and to the power supply line side. Select a capacitor whose ESR is as small as possible. ESR = 1 Ω or less is recommended.

- Guard ring of amplifier circuit board (see Fig. 3.3)

It is recommended to provide a guard ring around the input of the Op-amp and other areas where the micro signal is handled. In this example of the pattern, the periphery of the IN (+) terminal of the Op-amp U1 on the amplifier circuit board that receives I-V converted signals from the sensor circuit board, is guarded by the IN (-) terminal biased to the $V_{CC}/2$. This prevents noise and disturbance from entering the IN (+) terminal from other wiring due to line capacitance and stray capacitance, and prevents leakage current from flowing due to generation of voltage.

In order to prevent noise from jumping in due to the guard ring becoming a loop antenna, a break may be made in the middle. However, determine whether there is a break in the guard ring by experiment with an actual circuit board. In this example of the pattern, nothing is cut in consideration of jumping due to capacitive coupling between wires, but in this case, the surrounding area should be as small as possible to reduce the magnetic flux passing through the loop.

4. Product Overview

4.1. TC75S67TU

- Low input reduced noise voltage:
 $V_{NI}=16 \text{ nV}/\sqrt{\text{Hz}}$ (typ.) @ $f=10 \text{ Hz}$, $R_S=100 \Omega$, $R_F=10 \text{ k}\Omega$, $V_{DD}=2.5 \text{ V}$, $V_{SS}=\text{GND}$, $G_V=40\text{dB}$
 $V_{NI}=6 \text{ nV}/\sqrt{\text{Hz}}$ (typ.) @ $f=1 \text{ kHz}$, $R_S=100 \Omega$, $R_F=10 \text{ k}\Omega$, $V_{DD}=2.5 \text{ V}$, $V_{SS}=\text{GND}$, $G_V=40\text{dB}$
- Low-input biasing current: $I_I = 1\text{pA}$ (typ.)
- Low power supply current: $I_{DD} = 430 \mu\text{A}$ (typ.) @ $V_{DD}=2.5 \text{ V}$, $V_{SS} = \text{GND}$
- Low-power-supply-voltage driving: V_{DD} , $V_{SS}=2.2 \text{ to } 5.5 \text{ V}$

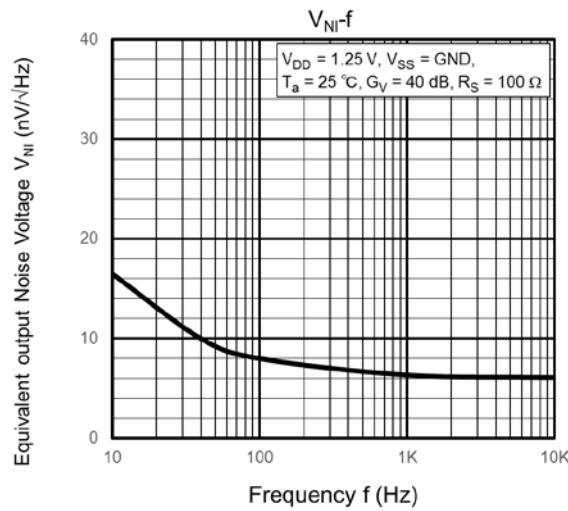

Fig. 4.1 Input Conversion Noise Voltage Characteristics

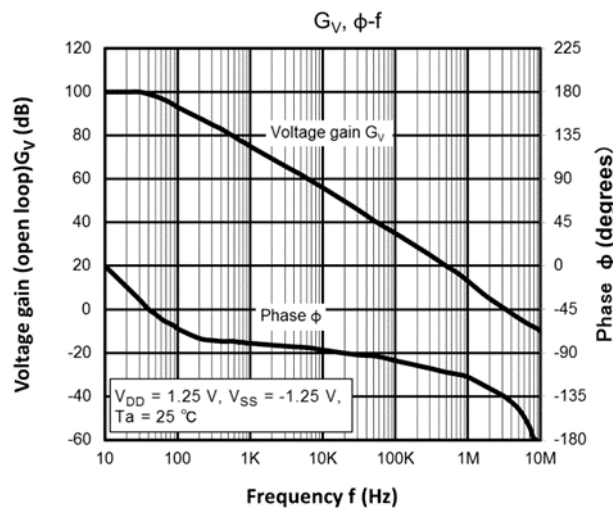

Fig. 4.2 Phase margin vs. Gain Characteristics

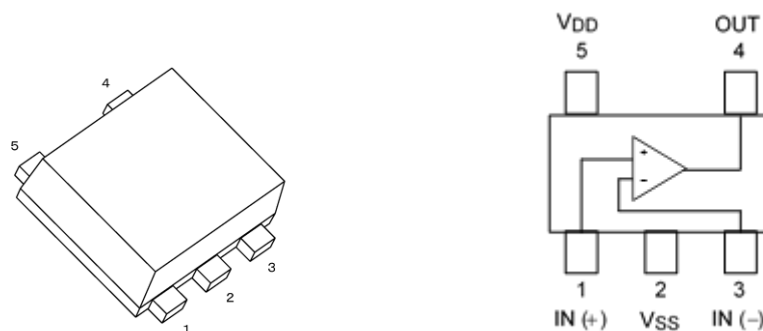

Fig. 4.3 Appearance and pin assignment

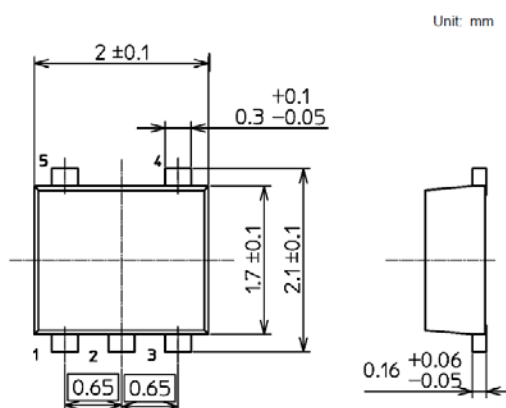

Fig. 4.4 Package dimensions

Refer to the Data Sheet for details of each property.

To download the datasheet for TC75S67TU → [Click Here](#)

4.2. Pin description

TABLE 4.1 TC75S67TU Pin description

Pin number	Pin name	Function
1	IN (+)	Non-inverting input terminal
2	V _{SS}	Connect to GND when using a single power supply for the negative power supply terminal.
3	IN (-)	Inverting input terminal
4	OUT	Output terminal
5	V _{DD}	The maximum rating when using the single power supply of the positive power supply terminal is 6 V. For stable operation, it is recommended to use 0.1 μF and 0.01 μF or more (ESR=1 Ω or less) capacitors as bypass capacitors.

Terms of Use

This terms of use is made between Toshiba Electronic Devices and Storage Corporation ("We") and customers who use documents and data that are consulted to design electronics applications on which our semiconductor devices are mounted ("this Reference Design"). Customers shall comply with this terms of use. Please note that it is assumed that customers agree to any and all this terms of use if customers download this Reference Design. We may, at its sole and exclusive discretion, change, alter, modify, add, and/or remove any part of this terms of use at any time without any prior notice. We may terminate this terms of use at any time and for any reason. Upon termination of this terms of use, customers shall destroy this Reference Design. In the event of any breach thereof by customers, customers shall destroy this Reference Design, and furnish us a written confirmation to prove such destruction.

1. Restrictions on usage

1. This Reference Design is provided solely as reference data for designing electronics applications. Customers shall not use this Reference Design for any other purpose, including without limitation, verification of reliability.
2. This Reference Design is for customer's own use and not for sale, lease or other transfer.
3. Customers shall not use this Reference Design for evaluation in high or low temperature, high humidity, or high electromagnetic environments.
4. This Reference Design shall not be used for or incorporated into any products or systems whose manufacture, use, or sale is prohibited under any applicable laws or regulations.

2. Limitations

1. We reserve the right to make changes to this Reference Design without notice.
2. This Reference Design should be treated as a reference only. We are not responsible for any incorrect or incomplete data and information.
3. Semiconductor devices can malfunction or fail. When designing electronics applications by referring to this Reference Design, customers are responsible for complying with safety standards and for providing adequate designs and safeguards for their hardware, software and systems which minimize risk and avoid situations in which a malfunction or failure of semiconductor devices could cause loss of human life, bodily injury or damage to property, including data loss or corruption. Customers must also refer to and comply with the latest versions of all relevant our information, including without limitation, specifications, data sheets and application notes for semiconductor devices, as well as the precautions and conditions set forth in the "Semiconductor Reliability Handbook".
4. When designing electronics applications by referring to this Reference Design, customers must evaluate the whole system adequately. Customers are solely responsible for all aspects of their own product design or applications. WE ASSUME NO LIABILITY FOR CUSTOMERS' PRODUCT DESIGN OR APPLICATIONS.
5. No responsibility is assumed by us for any infringement of patents or any other intellectual property rights of third parties that may result from the use of this Reference Design. No license to any intellectual property right is granted by this terms of use, whether express or implied, by estoppel or otherwise.
6. THIS REFERENCE DESIGN IS PROVIDED "AS IS". WE (a) ASSUME NO LIABILITY WHATSOEVER, INCLUDING WITHOUT LIMITATION, INDIRECT, CONSEQUENTIAL, SPECIAL, OR INCIDENTAL DAMAGES OR LOSS, INCLUDING WITHOUT LIMITATION, LOSS OF PROFITS, LOSS OF OPPORTUNITIES, BUSINESS INTERRUPTION AND LOSS OF DATA, AND (b) DISCLAIM ANY AND ALL EXPRESS OR IMPLIED WARRANTIES AND CONDITIONS RELATED TO THIS REFERENCE DESIGN, INCLUDING WARRANTIES OR CONDITIONS OF MERCHANTABILITY, FITNESS FOR A PARTICULAR PURPOSE, ACCURACY OF INFORMATION, OR NONINFRINGEMENT.

3. Export Control

Customers shall not use or otherwise make available this Reference Design for any military purposes, including without limitation, for the design, development, use, stockpiling or manufacturing of nuclear, chemical, or biological weapons or missile technology products (mass destruction weapons). This Reference Design may be controlled under the applicable export laws and regulations including, without limitation, the Japanese Foreign Exchange and Foreign Trade Law and the U.S. Export Administration Regulations. Export and re-export of this Reference Design are strictly prohibited except in compliance with all applicable export laws and regulations.

4. Governing Laws

This terms of use shall be governed and construed by laws of Japan.