

Application Circuit of Low Noise Op-Amp TC75S67TU for Ultrasonic Distance Sensor

Reference Guide

RD162-RGUIDE-01

Overview

This Reference Guide (hereinafter referred to as "this guide") describes the specifications, board pattern diagram, usage, and characteristics of ultrasonic distance sensors using a low-noise op-amp TC75S67TU. Operation control and result display can be performed on the PC using the microcontroller, and the software is also prepared. Please refer to this guide when designing this sensor using TC75S67TU.

TOSHIBA ELECTRONIC DEVICES & STORAGE CORPORATION

Table of Contents

1. Introduction	3
2. Ultrasonic Distance Sensor.....	4
2.1. Specifications.....	4
2.2. Appearance.....	5
3. Ultrasonic Distance Sensor Schematics and Board Pattern.....	6
3.1. Schematics.....	6
3.2. Bill of Materials	7
3.3. Board Pattern Drawing.....	9
4. Operation Procedure.....	12
4.1. About Arduino and Processing.....	12
4.2. Connection to Arduino.....	12
4.3. Start and Stop.....	13
4.4. Precautions for Distance Measurement.....	15
5. Distance Measurement Results	16

1. Introduction

The ultrasonic transducer for the ultrasonic distance sensors (hereinafter referred to as "this sensor") described in this guide uses C4016A1 manufactured by Nippon Ceramic Co., Ltd with integrated transmitter and receiver. It is designed to measure distances from 40 cm to up to 6 m and can be widely used for various mid-range measurement applications such as detecting objects with drones and measuring water levels in rivers, etc.

The signal output from this sensor board is processed by the microcontroller to calculate the distance and the result is displayed. In this guide, Arduino is used for the microcontroller to enable voltage supplied from Arduino, so in addition to this sensor, it can be used as an ultrasonic distance sensor if Arduino and a personal computer are available.

To download of the various offer information on this sensor reference design →

[Click Here](#)

The components other than the op-amp are also mounted on a compact board size of 20 mm x 40 mm using surface mount, making it easy to use for a variety of applications.

Note that the circuit and board pattern prepared by the reference design of this sensor described in this guide have jumpers and lands for un-mounted elements in consideration of expandability such as enhancement of noise suppression. In the schematic and bill of materials, the jumper is described as 0 Ω , and the non-mounted elements are described as "Not mounted". In addition, the wiring on the circuit diagram is indicated by dotted lines.

2. Ultrasonic Distance Sensor

2.1. Specifications

Table 2.1 Specifications

Item	Specifications
I/F	Arduino connections
Control method	Control from Arduino and Shield Connected PCs
Power supply voltage	5 V from Arduino and Shield board
Measurement distance	40 cm~6 m
Onboard ultrasonic sensor	Nippon Ceramic C4016A1, Integrated transmitter and receiver
Measured ultrasonic frequency	40 kHz
Onboard operational amplifier	Toshiba Device & Storage TC75S67TU

2.2. Appearance

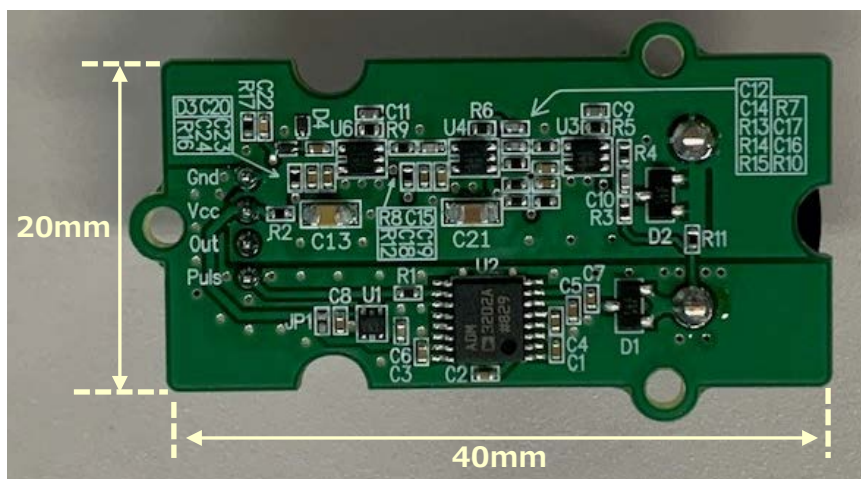

Fig.2.1 Appearance (Top side)

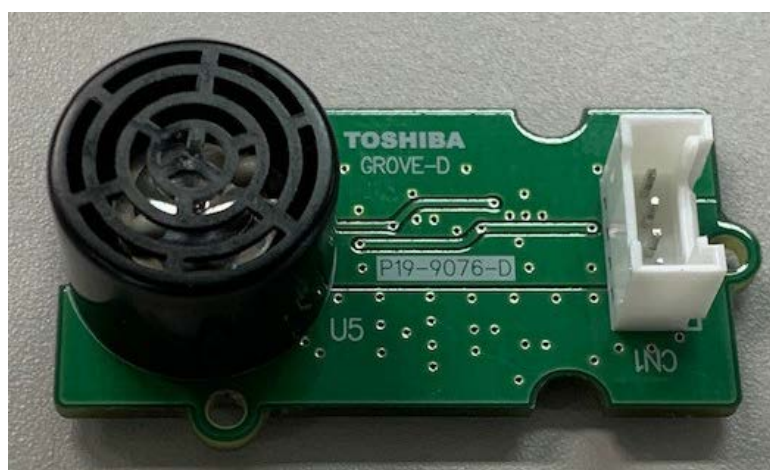

Fig.2.2 Appearance (Bottom Side)

3. Ultrasonic Distance Sensor Schematics and Board Pattern

3.1. Schematics

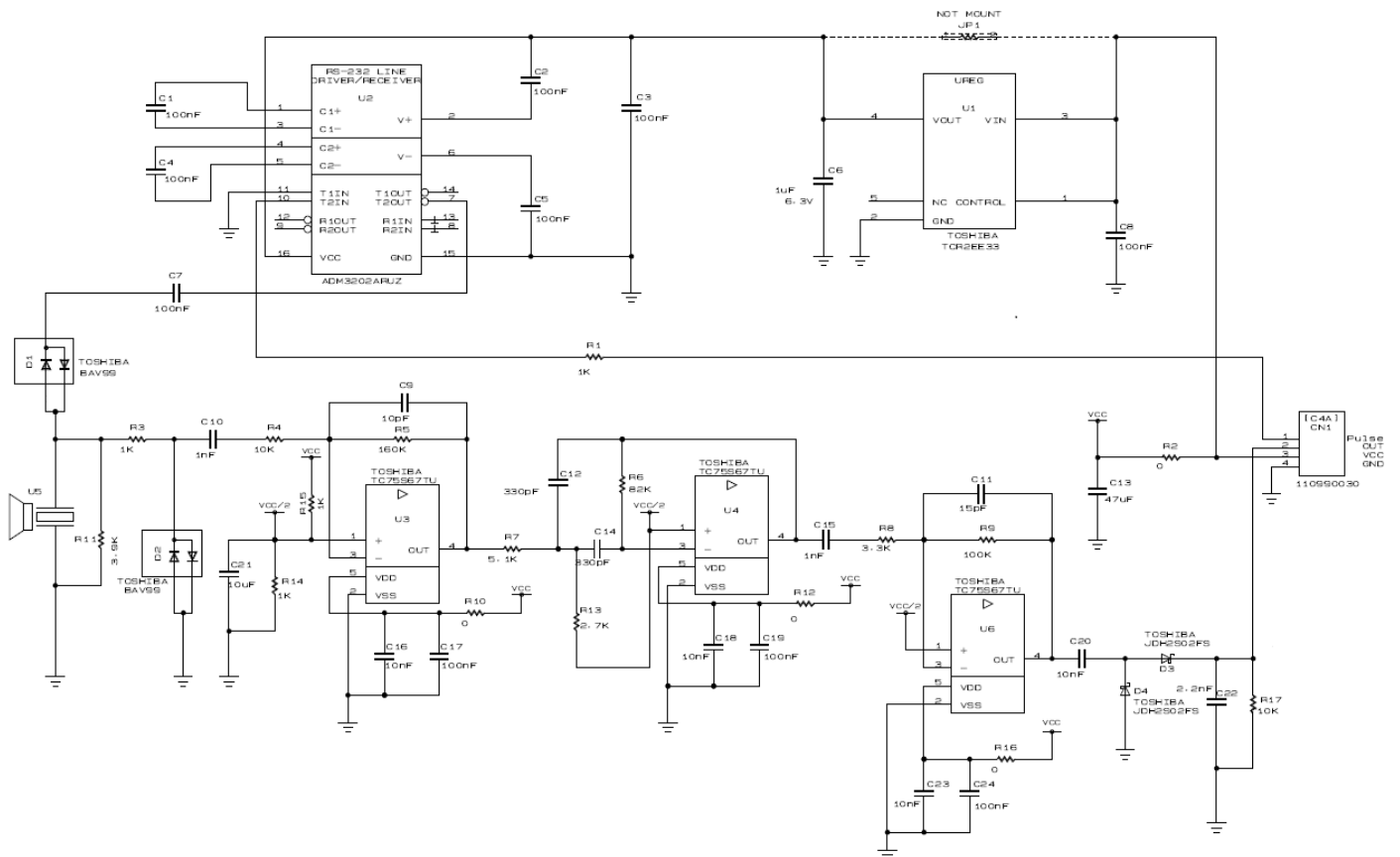

Fig.3.1 Schematics

3.2. Bill of Materials

Table 3.1 Bill of Materials (Part 1)

Item	Part	Quantity	Value	Part name	Manufacturer	Description	Package Name	Standard Dimensions mm (inch)
1	U1	1	-	TCR2EE33	TOSHIBA	LDO regulator	SOT-553	1.6×1.6×0.55
2	U2	1	-	ADM3202ARUZ	Analog Devices	Interface IC	TSSOP-16	4.5×6.6×1.1
3	U3, U4, U6	3	-	TC75S67TU	TOSHIBA	Operational amplifier	SOT-353F	2.0×2.1×0.7
4	U5	1	-	C4016A1	Nippon Ceramic	Ultrasonic sensors		Φ16.2×12
5	D1, D2	2	-	BAV99	TOSHIBA	Switching Diode	SOT23	2.9×2.4×0.9
6	D3, D4	2	-	JDH2S02FS	TOSHIBA	Schottky barrier Diode	FsC	1.0×0.6×0.48
7	C1, C2, C3, C4, C5, C7, C8, C17, C19, C24	10	100 nF			Ceramic 16 V, ±10 %		1.0×0.5 (0402)
8	C6	1	1 μF			Ceramic 6.3 V, ±10 %		1.0×0.5 (0402)
9	C9	1	10 pF			Ceramic 50 V, ±5 %		1.0×0.5 (0402)
10	C10, C15	2	1 nF			Ceramic 50 V, ±5 %		1.0×0.5 (0402)
11	C11	1	15 pF			Ceramic 50 V, ±5 %		1.0×0.5 (0402)
12	C12, C14	2	330 pF			Ceramic 50 V, ±5 %		1.0×0.5 (0402)
13	C13	1	47 μF			Ceramic 6.3 V, ±20 %		2.0×1.2 (0805)
14	C16, C18, C20, C23	4	10 nF			Ceramic 25 V, ±10 %		1.0×0.5 (0402)
15	C21	1	10 μF			Ceramic 25 V, ±10 %		2.0×1.2 (0805)
16	C22	1	2.2 nF			Ceramic 50 V, ±10 %		1.0×0.5 (0402)

Table 3.2 Bill of Materials (Part 2)

Item	Part	Quantity	Value	Part name	Manufacturer	Description	Package Name	Standard Dimensions mm (inch)
17	R1, R3, R14, R15	4	1 kΩ			100 mW, ±1 %		1.0×0.5 (0402)
18	R2, R10, R12, R16	4	0 Ω			1 A		1.0×0.5 (0402)
19	R4, R17	2	10 kΩ			100 mW, ±1 %		1.0×0.5 (0402)
20	R5	1	160 kΩ			100 mW, ±1 %		1.0×0.5 (0402)
21	R6	1	82 kΩ			100 mW, ±1 %		1.0×0.5 (0402)
22	R7	1	5.1 kΩ			100 mW, ±1 %		1.0×0.5 (0402)
23	R8	1	3.3 kΩ			100 mW, ±1 %		1.0×0.5 (0402)
24	R9	1	100 kΩ			100 mW, ±1 %		1.0×0.5 (0402)
25	R11	1	3.9 kΩ			100 mW, ±1 %		1.0×0.5 (0402)
26	R13	1	2.7 kΩ			100 mW, ±1 %		1.0×0.5 (0402)
27	CN2	1	-	110990030	Seeed Studio	Grove connector 4-pin/straight		10×5.1×8.1

3.3. Board Pattern Drawing

This board consists of both top and bottom side pattern. The part mounting side is shown as the top side and the ultrasonic sensor and connector are mounted on the bottom side.

<Top Side (Parts Mounting Side)>

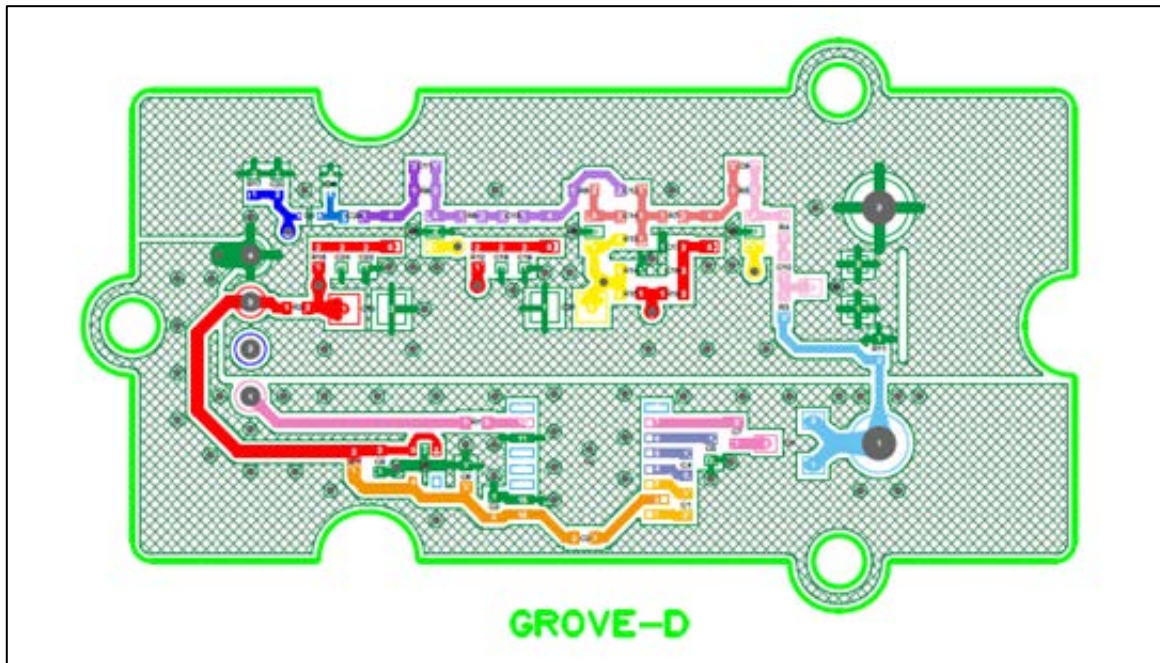

Fig.3.2 Board Pattern

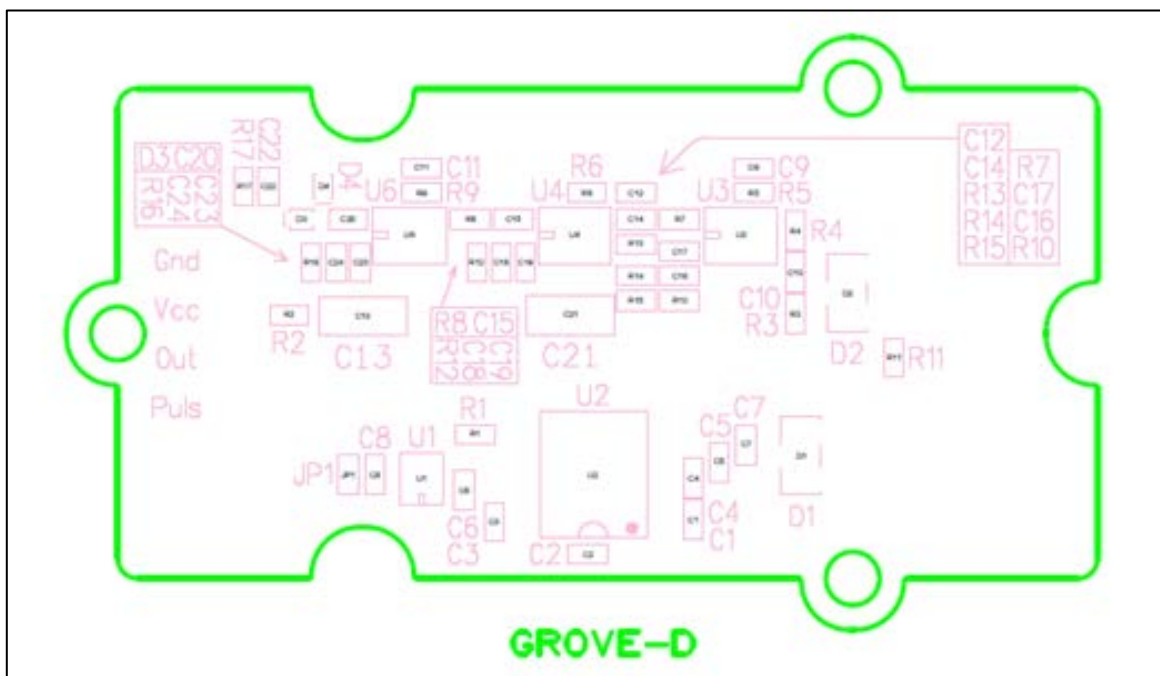

Fig.3.3 Substrate Silk

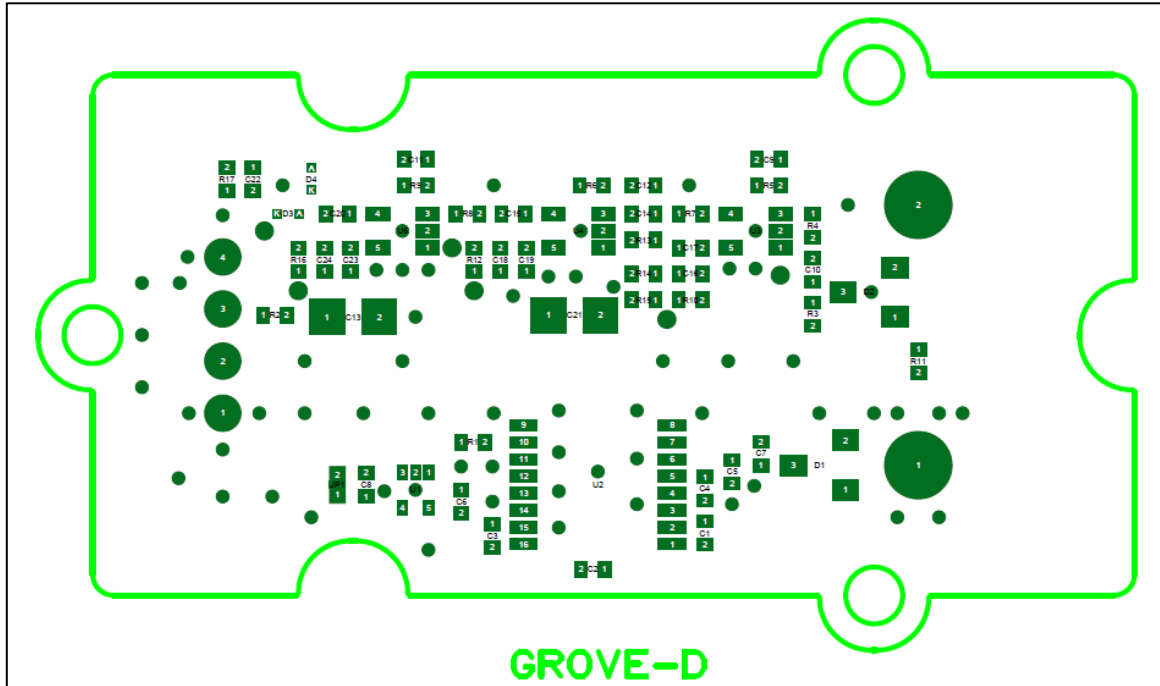

Fig.3.4 Substrate Solder

<Bottom Side>

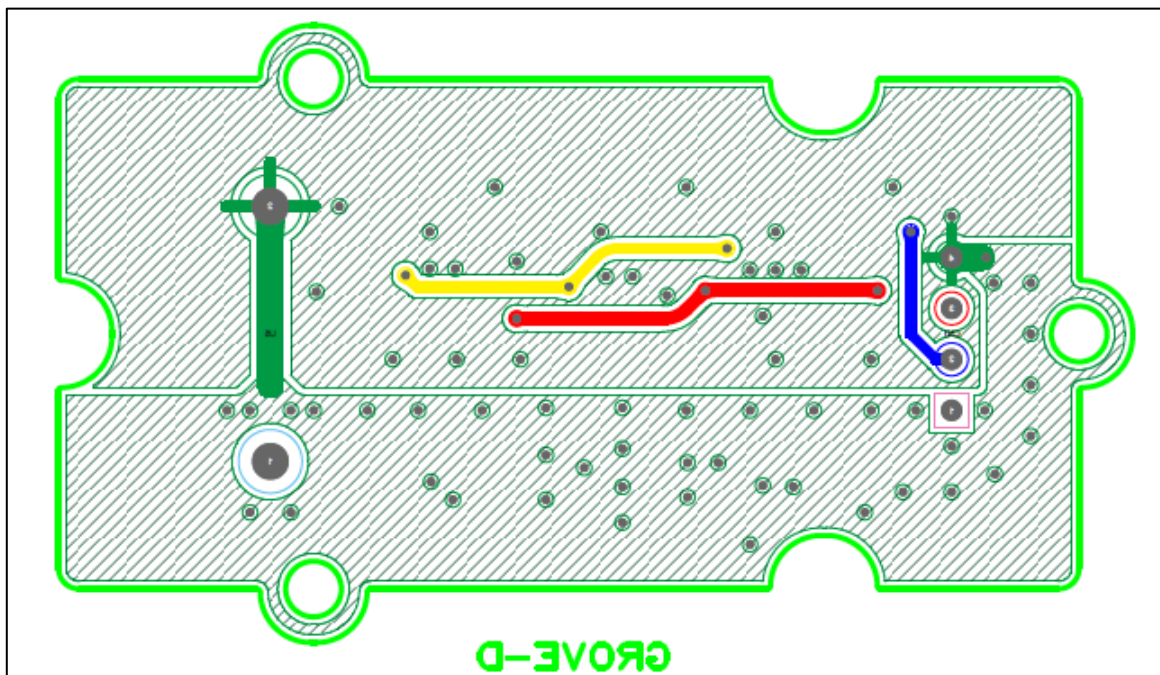

Fig.3.5 Board Pattern

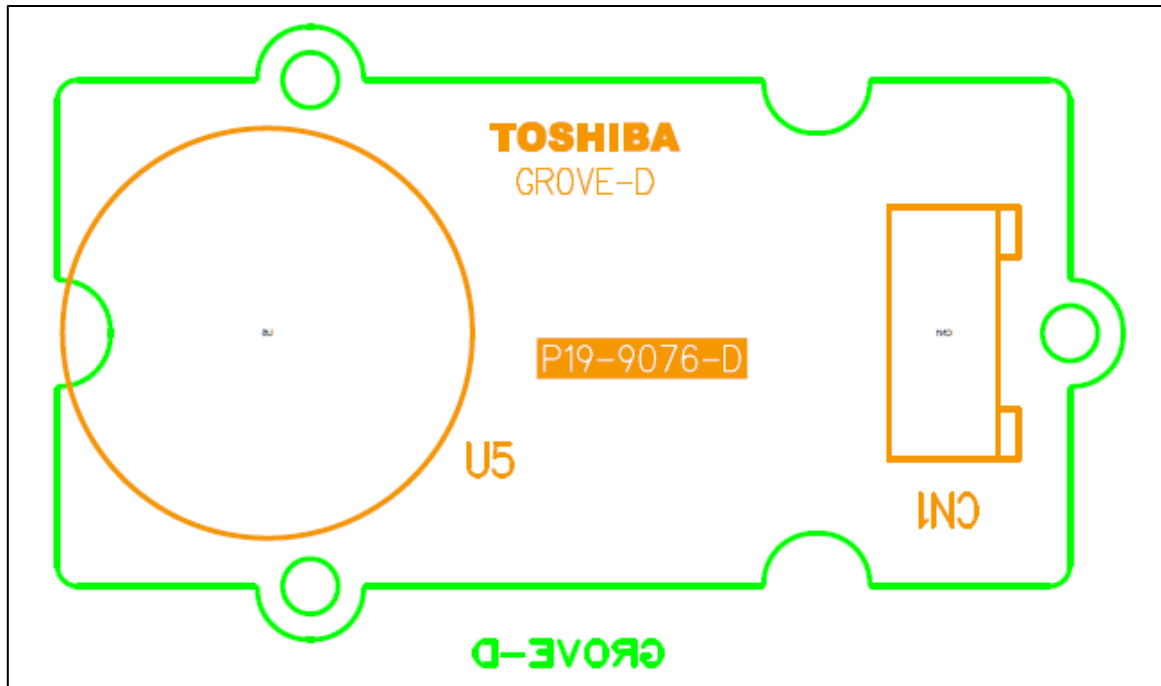

Fig.3.6 Substrate Silk

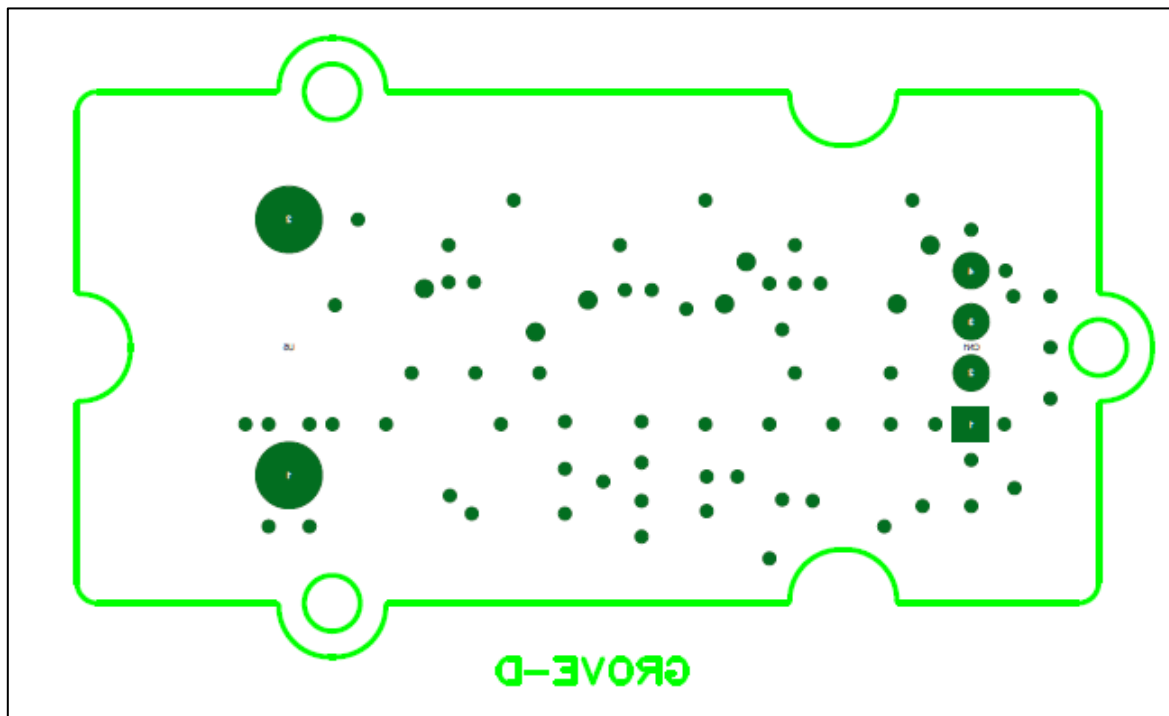

Fig.3.7 Substrate Solder

4. Operation Procedure

4.1. About Arduino and Processing

Arduino is a palm-sized one-board microcontroller. The microcontroller is selected as the control microcontroller for this reference design because it is generally available on the market and can be easily got, and if the program is transferred once, the sensor can be operated without a PC. Use the Processing to display the measurement results on the PC-screen.

This reference design provides Arduino operating program and a Processing program that displays the status of measurements. To run this program, you must install Arduino IDE and Processing 3 on your PCs. Both software are available free of charge on their official sites. Download the software and install it on your PC in advance. These software are also needed to edit each program. These programs are called "sketches" in Arduino, Processing.

Moreover, in the case of Windows10, a display window for result of Processing may not start. In such a case, it is necessary to change the configuration file of initial value that generated automatically at the first time start-up of Processing. Since a solution change with PCs, please implement a suitable solution with reference to Web etc.

Refer to the Commercial Instructions for more information on Arduino and Processing.

4.2. Connection to Arduino

Fig.4.1 shows the connections to the Arduino.

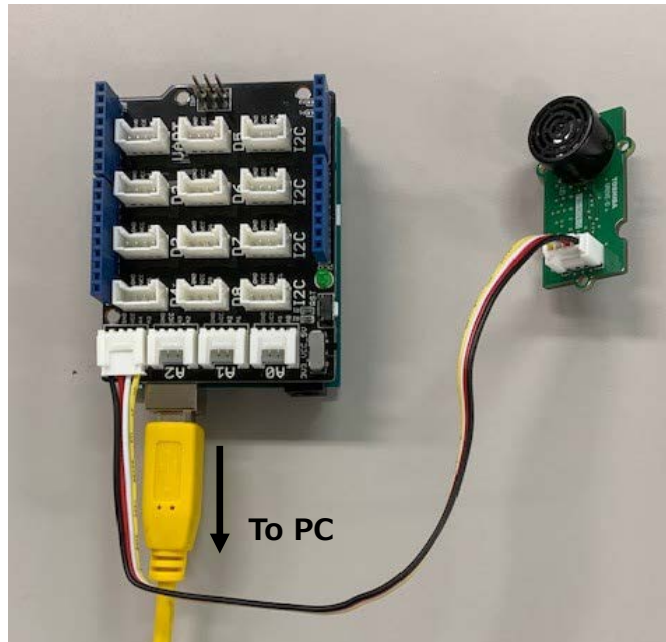

Fig. 4.1 Connections to Arduino

Arduino is used with "seed studio Base Shield". The connection port of the base shield to the sensor is connected A3 terminal. Connect the base shield and the PC with a USB cable.

4.3. Start and Stop

When the compressed file "RD162-SKETCH-01_E.zip" of the sketch prepared for this sensor is downloaded from the following link and decompressed in an appropriate place on the PC, the folder containing the two files "US_sensor_Arduino.ino" and "Ultrasonic_sensor.pde" and the usage convention is created. Save the file as is.

To download sketches → [Click Here](#)

Start the Arduino IDE and select "File" → "Open" to open the saved US_sensor_Arduino.ino file. The window shown on the left of Fig. 4.2 opens separately from the window opened at startup. Select "Sketch" → "Upload" to start compiling the files and write the sketch to the Arduino after compiling. When writing is completed successfully, a message appears at the bottom of the window. The Arduino is now ready.

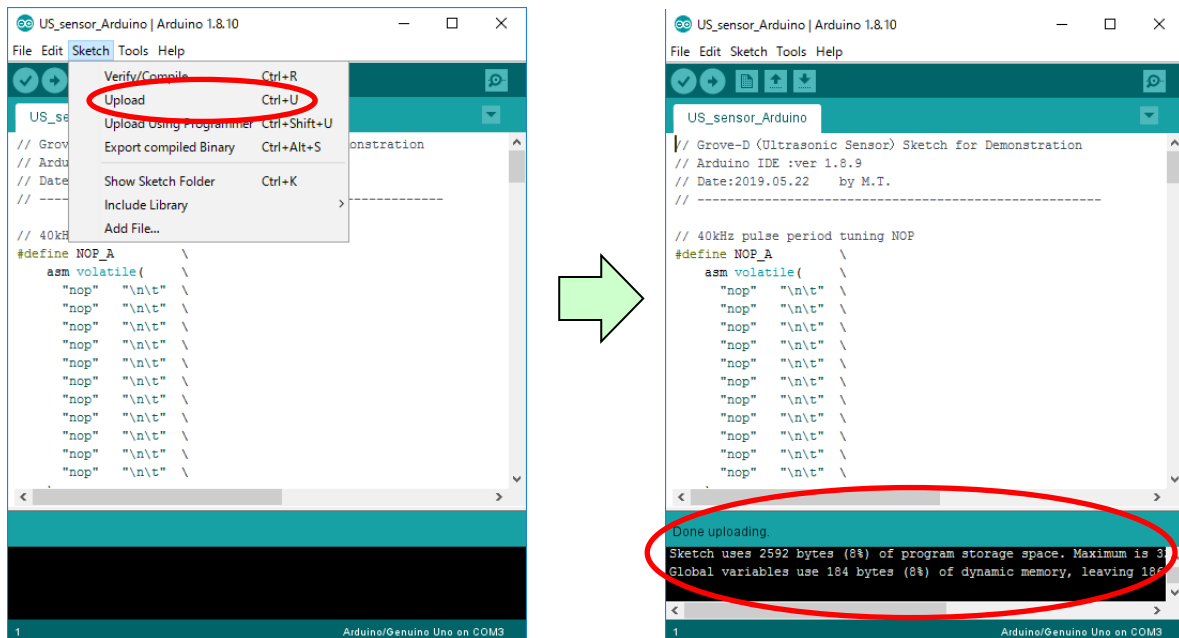

Fig. 4.2 Arduino IDE Window

Then start the Processing 3. When you start the Processing 3, the window shown in Fig. 4.3 opens. Click Get Started at the bottom right of the child window. Then, select File → Open to open the saved Ultrasonic_sensor.pde file.

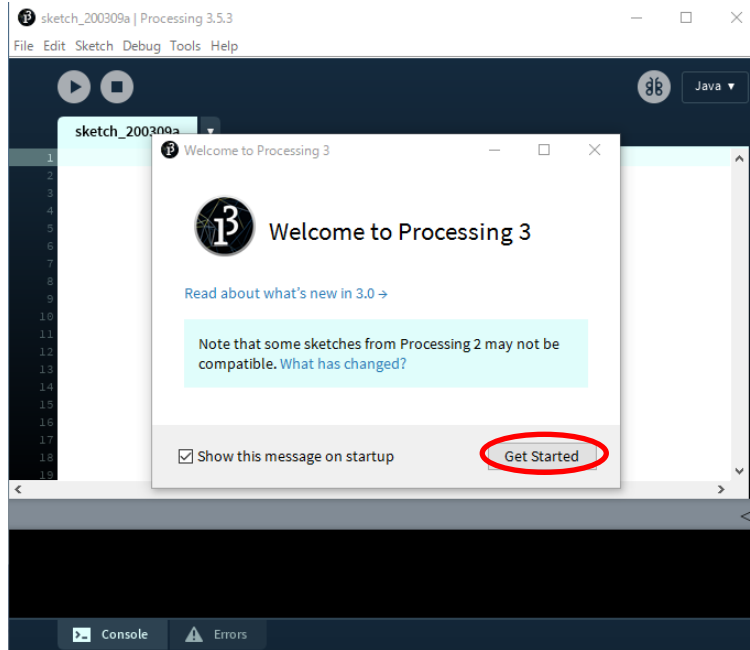

Fig.4.3 Startup Window of Processing 3

The window shown in Fig.4.4 opens separately from the window opened at startup. Click the operation button (red circle) here to open the result display window and start the measurement.

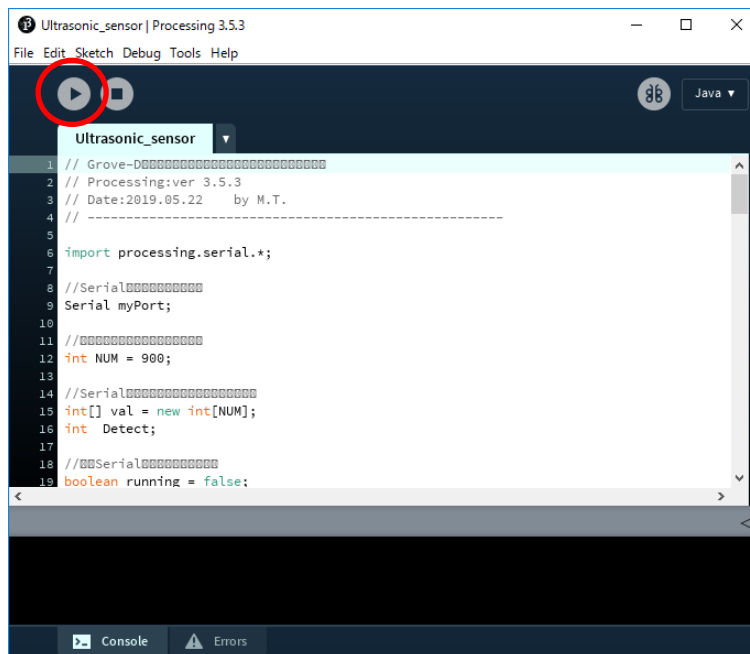

Fig. 4.4 Processing Measurement Start Window

5. Distance Measurement Results

Fig.5.1 shows the transmission and reception waveforms when measuring a distance of approximately 2 m with the ultrasonic distance sensor in this guide. The yellow waveform is the 40-kHz burst signal output from Arduino, and the green waveform is the sensor output signal input to Arduino.

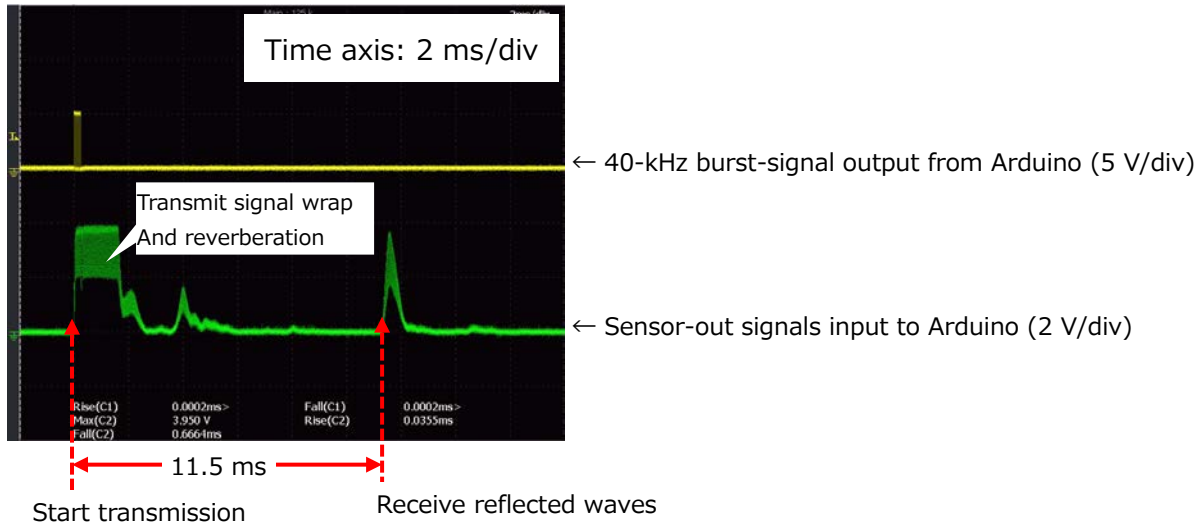

Fig.5.1 Example Burst Waveform Observed by an Oscilloscope

In this waveform, the time from the start of transmission until the reception of the reflected wave is obtained as 11.5 ms. In this case, the distance is calculated as 1.96 m as shown in Equation 5.1. In this example, the speed of sound is assumed to be 340 m/s at room temperature. The time measured with this waveform is divided by 2 because it is the time for the ultrasonic wave to and from the object to be measured.

$$D = \frac{v \times t}{2} = \frac{340 \times 11.5 \times 10^{-3}}{2} \cong 1.96 \text{ (m)} \quad \dots (5.1)$$

D: Distance (m), v: Sound velocity (m/s), t: Propagation time (s)

Fig.5.2 shows the window for displaying the measurement results of Processing at this time. The results window shows the distances processed and calculated by Arduino and matches the values found in Equation (5.1).

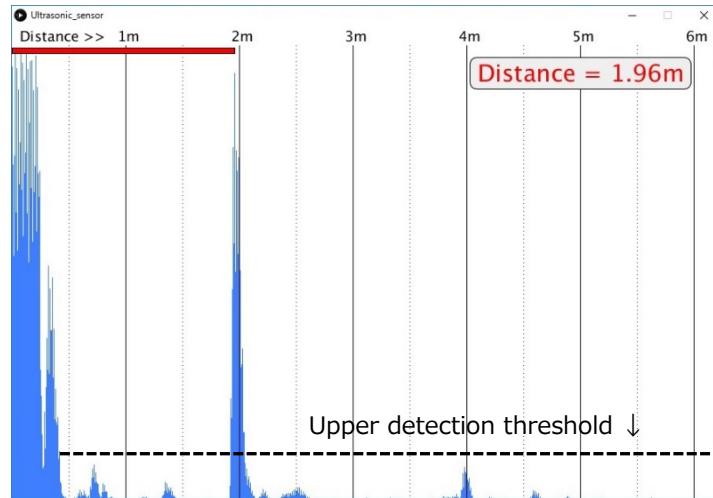

Fig. 5.2 Measuring Result Indication by Processing

Terms of Use

This terms of use is made between Toshiba Electronic Devices and Storage Corporation ("We") and customers who use documents and data that are consulted to design electronics applications on which our semiconductor devices are mounted ("this Reference Design"). Customers shall comply with this terms of use. Please note that it is assumed that customers agree to any and all this terms of use if customers download this Reference Design. We may, at its sole and exclusive discretion, change, alter, modify, add, and/or remove any part of this terms of use at any time without any prior notice. We may terminate this terms of use at any time and for any reason. Upon termination of this terms of use, customers shall destroy this Reference Design. In the event of any breach thereof by customers, customers shall destroy this Reference Design, and furnish us a written confirmation to prove such destruction.

1. Restrictions on usage

1. This Reference Design is provided solely as reference data for designing electronics applications. Customers shall not use this Reference Design for any other purpose, including without limitation, verification of reliability.
2. This Reference Design is for customer's own use and not for sale, lease or other transfer.
3. Customers shall not use this Reference Design for evaluation in high or low temperature, high humidity, or high electromagnetic environments.
4. This Reference Design shall not be used for or incorporated into any products or systems whose manufacture, use, or sale is prohibited under any applicable laws or regulations.

2. Limitations

1. We reserve the right to make changes to this Reference Design without notice.
2. This Reference Design should be treated as a reference only. We are not responsible for any incorrect or incomplete data and information.
3. Semiconductor devices can malfunction or fail. When designing electronics applications by referring to this Reference Design, customers are responsible for complying with safety standards and for providing adequate designs and safeguards for their hardware, software and systems which minimize risk and avoid situations in which a malfunction or failure of semiconductor devices could cause loss of human life, bodily injury or damage to property, including data loss or corruption. Customers must also refer to and comply with the latest versions of all relevant our information, including without limitation, specifications, data sheets and application notes for semiconductor devices, as well as the precautions and conditions set forth in the "Semiconductor Reliability Handbook".
4. When designing electronics applications by referring to this Reference Design, customers must evaluate the whole system adequately. Customers are solely responsible for all aspects of their own product design or applications. WE ASSUME NO LIABILITY FOR CUSTOMERS' PRODUCT DESIGN OR APPLICATIONS.
5. No responsibility is assumed by us for any infringement of patents or any other intellectual property rights of third parties that may result from the use of this Reference Design. No license to any intellectual property right is granted by this terms of use, whether express or implied, by estoppel or otherwise.
6. THIS REFERENCE DESIGN IS PROVIDED "AS IS". WE (a) ASSUME NO LIABILITY WHATSOEVER, INCLUDING WITHOUT LIMITATION, INDIRECT, CONSEQUENTIAL, SPECIAL, OR INCIDENTAL DAMAGES OR LOSS, INCLUDING WITHOUT LIMITATION, LOSS OF PROFITS, LOSS OF OPPORTUNITIES, BUSINESS INTERRUPTION AND LOSS OF DATA, AND (b) DISCLAIM ANY AND ALL EXPRESS OR IMPLIED WARRANTIES AND CONDITIONS RELATED TO THIS REFERENCE DESIGN, INCLUDING WARRANTIES OR CONDITIONS OF MERCHANTABILITY, FITNESS FOR A PARTICULAR PURPOSE, ACCURACY OF INFORMATION, OR NONINFRINGEMENT.

3. Export Control

Customers shall not use or otherwise make available this Reference Design for any military purposes, including without limitation, for the design, development, use, stockpiling or manufacturing of nuclear, chemical, or biological weapons or missile technology products (mass destruction weapons). This Reference Design may be controlled under the applicable export laws and regulations including, without limitation, the Japanese Foreign Exchange and Foreign Trade Law and the U.S. Export Administration Regulations. Export and re-export of this Reference Design are strictly prohibited except in compliance with all applicable export laws and regulations.

4. Governing Laws

This terms of use shall be governed and construed by laws of Japan.