

Application Circuits of eFuse IC TCKE805 Series

Reference Guide

RD164-RGUIDE-01

Overview

This document explains the specifications, bill of materials, patterns, operating procedures, and operating waveforms of application circuit boards using our eFuse IC TCKE805 series. The application circuit board is designed to be incorporated into various devices as they are. Please refer to this when designing an application with the TCKE805 Series.

TOSHIBA ELECTRONIC DEVICES & STORAGE CORPORATION

Table of Contents

1. Introduction	3
2. Specifications and appearance	4
2.1. Specifications	4
2.2. Appearance and parts layout of the application circuit board	5
3. Details of application circuit board	6
3.1. Application circuit (with reverse current protection)	6
3.2. Bill of materials.....	6
3.3. PCB pattern diagram.....	7
4. Operation procedure	8
4.1. Connecting to an external device.....	8
4.2. To start and stop.....	8
4.3. Important reminder for use	8
5. Function waveform	9
5.1. Overcurrent protection function	9
5.2. Overvoltage protection function	10
5.3. Inrush current suppression function.....	10

1. Introduction

This reference guide explains the specifications, appearance, circuit, pattern diagrams, and operation of eFuse IC TCKE805 Series application circuit boards.

The TCKE805 Series has two types: an auto-retry type (TCKE805NA) which attempts to automatically recover from various protection operations, and a latch type (TCKE805NL) which recovers by restarting with external signals. In addition to various protection functions such as overcurrent, overvoltage, short-circuit, and overheating, they also have a rush current suppression function that controls the rise slew rate of the output voltage when the power is turned on, and a low-voltage malfunction prevention function that can set the operation voltage. Optionally, an external MOSFET can be added to protect reverse current from the output side to the input side.

The eFuse IC is used by inserting it into the power lines of the equipment, as in conventional fuses, and is not used by itself, because it is always connected to the power lines of the equipment. The application circuits described in this guide are integrated into a compact-sized board of 16 mm×24 mm using surface-mounted package in the peripheral components of the TCKE805NA/NL, and the application circuits are designed so that they can be mounted on various devices. In addition, an external MOSFET has been installed to use the reverse current protection function.

The auto-retry type and latch type application circuits are the same, so either type of application circuit is available for this guide.

Note that lands for unmounted devices are placed in the application circuits and board patterns described in this guide in consideration of variation (change of operating voltage to prevent low-voltage malfunction). In circuit diagrams and component tables, unmounted elements are described as "Not mounted". Also, the wiring on the circuit diagram is indicated by a dotted line.

2. Specifications and appearance

2.1. Specifications

The application circuit is designed to control the operation of the application circuit by transmitting signals from the outside to the EN/UVLO pin. It is also designed to use a reverse current protection function. Table 2.1 shows the main specifications of the application circuit.

Table 2.1 Specifications of application circuit for TCKE805 Series

Item	Specifications
Overvoltage protection clamp voltage	6.04 V
Overcurrent protection current limit	2.96 A
Inrush current limit ($V_{IN}=5V$)	0.6 ms
eFuse IC	Toshiba Devices & Storage Corporation TCKE805NA/TCKE805NL
Reverse current protection external N-ch MOSFET (If used)	Toshiba Devices & Storage Corporation SSM6K513NU

2.2. Appearance and parts layout of the application circuit board

Fig. 2.1 shows the application circuit board appearance, and Fig. 2.2 shows the layout of parts.

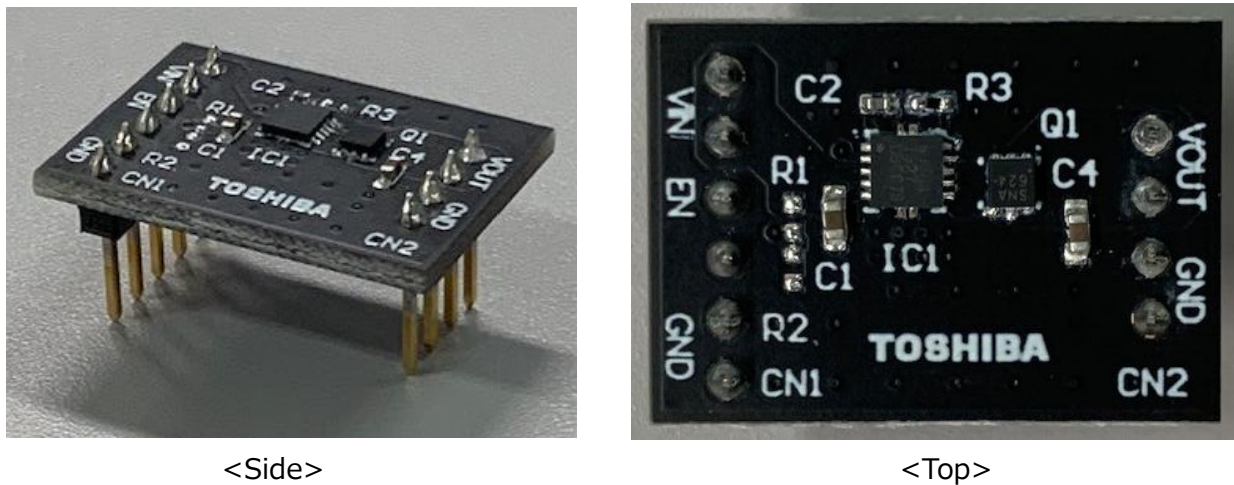

Fig. 2.1 Appearance of TCKE805 Series application circuit board

This application circuit board is designed to be connected to other devices (PCBs) by using pins to take out each pin.

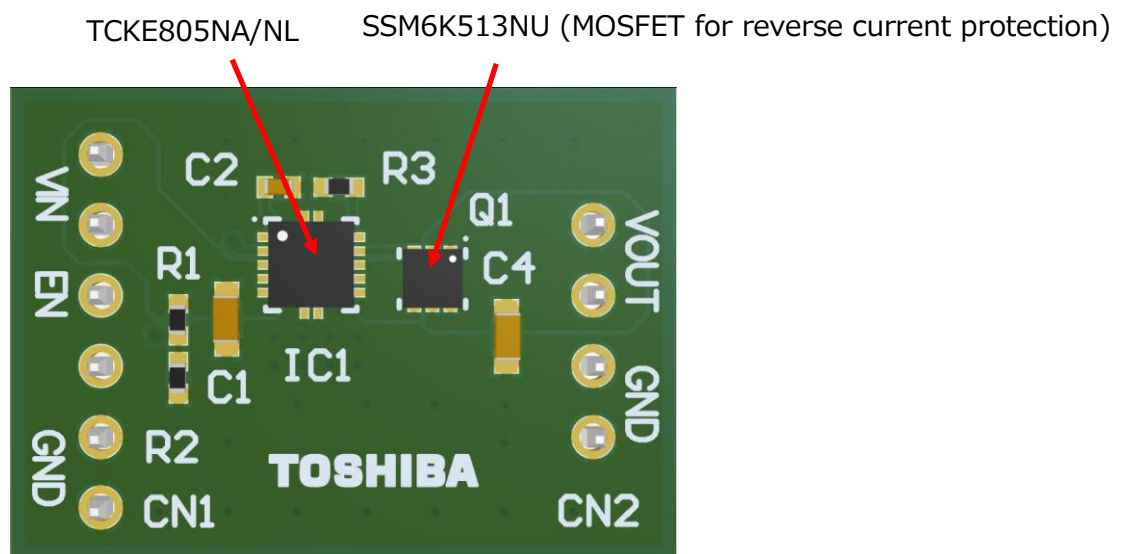

Fig. 2.2 Pattern layout of TCKE805 Series application circuit board

3. Details of application circuit board

3.1. Application circuit (with reverse current protection)

Fig. 3.1 shows the application circuit of the TCKE805NA/NL described in this document.

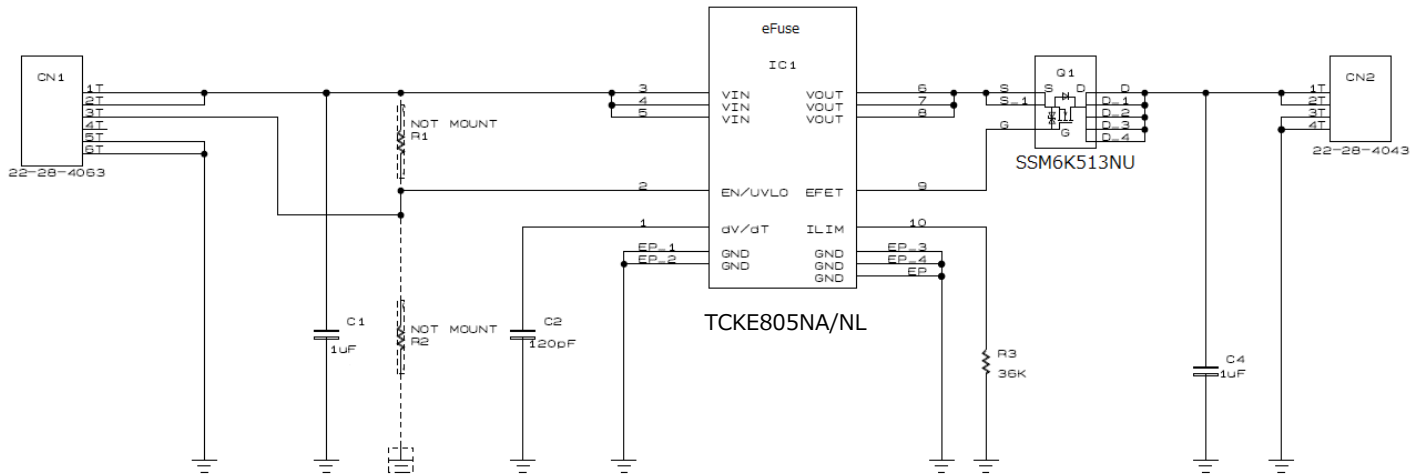

Fig. 3.1 Application circuit using reverse current protection function

3.2. Bill of materials

Table 3.1 shows the bill of materials.

Table 3.1 Bill of materials

Item	Part	Quantity	Value	Part number	Manufacturer	Description	Package type	Standard dimension mm (inch)	Comments
1	IC1	1	-	TCKE805	TOSHIBA	eFuse IC	WSO10B	3.0×3.0×0.7	All NA/NL can be used
2	Q1	1	-	SSM6K513NU	TOSHIBA	Nch MOSFET	UDFN6B	2.0×2.0×0.75	
3	C1, C4	2	1 µF			Ceramic 25 V, ±10 %		1.6×0.8 (0603)	
4	C2	1	120 pF			Ceramic 50 V, ±5 %		1.0×0.5 (0402)	
5	R1, R2	2						1.0×0.5 (0402)	Not mounted
6	R3	1	36 kΩ			100 mW, ±1 %		1.0×0.5 (0402)	
7	CN1	1	-	0022284063	Molex	Test pin 6 pins		Pitch of 2.54 mm	
8	CN2	1	-	022284043	Molex	Test pin 4 pins		Pitch of 2.54 mm	

3.3. PCB pattern diagram

Fig. 3.2 and Fig. 3.3 show the top pattern and the bottom pattern of the PCB, respectively.

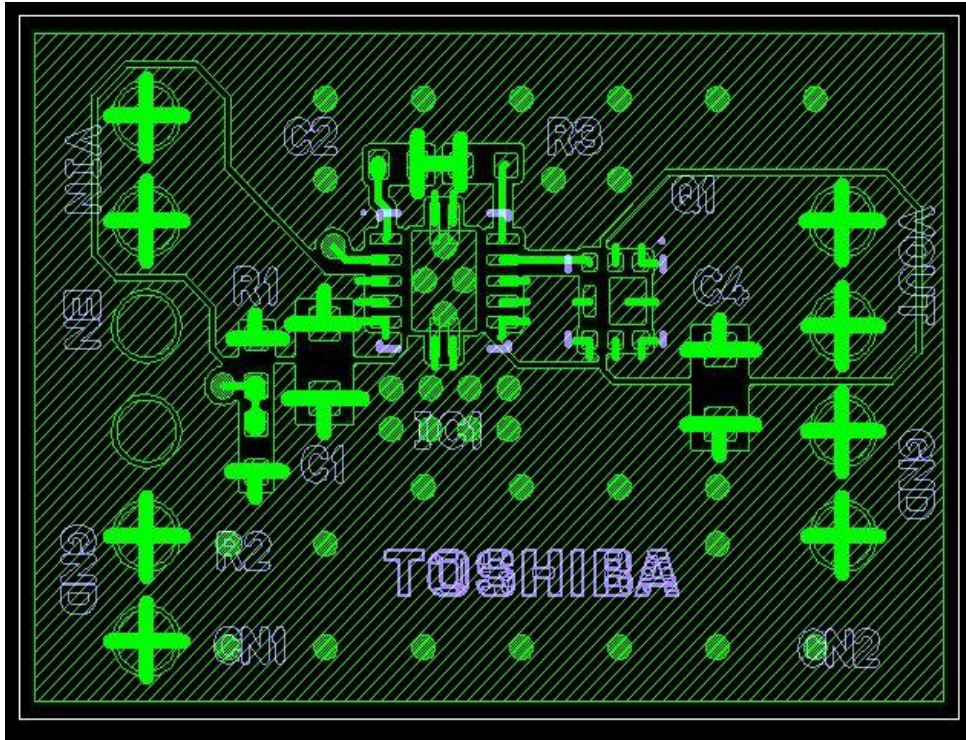

Fig. 3.2 Substrate pattern diagram (Top side)

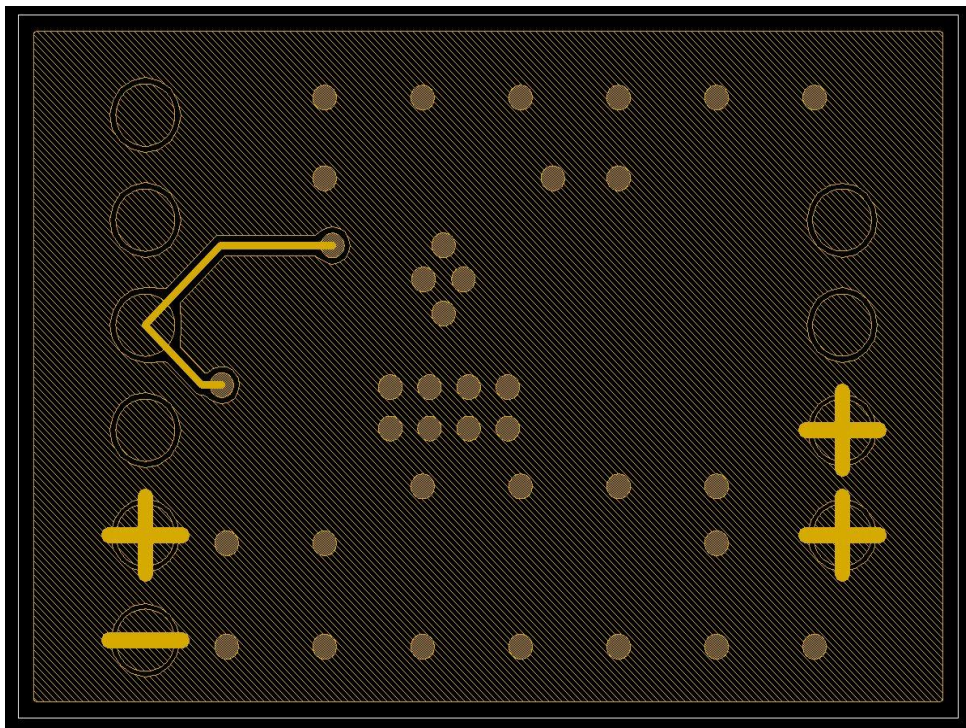

Fig. 3.3 Patterns of substrates (Bottom)

4. Operation procedure

4.1. Connecting to an external device

When mounting this application circuit board to the equipment as it is, use a connector for connection. Molex 22182061 can be used for the input side (pin 6) and 22182041 can be used for the output side (pin 4) as well.

Fig. 4.1 shows the connections with external devices. The VIN, VOUT, and GND pins on the PCB are connected to each other by two pins, but all of them are shorted by the PCB patterns.

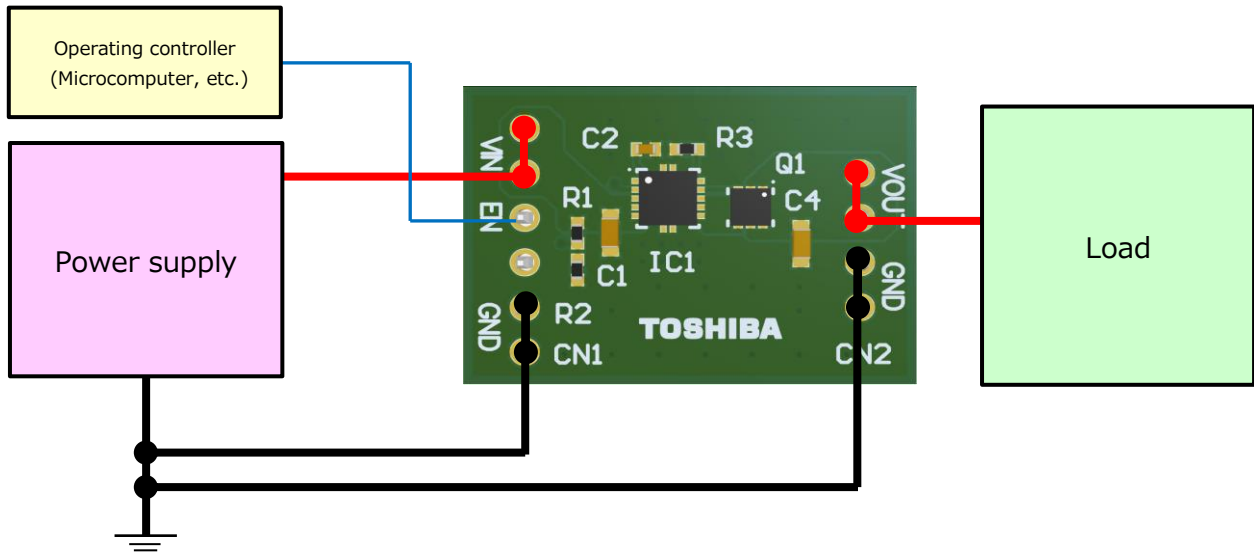

Fig. 4.1 Connection of application circuit board and external device

Use a power supply with as low noise as possible in order to operate stability.

This application circuit is designed to control the operation of the TCKE805NA/NL by external signals. Connect a control circuit such as a micro-computer to the EN/UVLO pin. On the board in Fig. 4.1, EN is indicated. If the operation is not controlled by this pin, the product can be directly connected to the power supply.

4.2. To start and stop

The standard procedure for starting up is as follows.

1. Turn on the power supply with the EN/UVLO pin at Low level.
2. Enter the High signal to the EN/UVLO pin. This starts the IC operation.

Stopping is the back steps from 2. to 1. if the EN/UVLO pin is connected directly to the power supply, the procedures described in 1. And 2. Above will be performed at once.

4.3. Important reminder for use

If the EN/UVLO pin is open (indefinite), the ICs may not operate properly. Make sure this pin is not open regardless of the level of the input signal to the EN/UVLO pin.

5. Function waveform

TCKE805NA/NL is a type of load switch that replaces conventional fuses. The overcurrent, overvoltage, and inrush current suppression functions of this application circuit are shown as the operation waveforms of the overcurrent, overvoltage, and inrush current suppression functions, respectively, are important.

5.1. Overcurrent protection function

Fig. 5.1 shows the overcurrent protection operation waveform. These waveforms are obtained by observing the output voltage V_{OUT} and the output current I_{OUT} when the operation is started with the V_{OUT} pin short-circuited to ground. The output voltage does not rise because it is short-circuited, and the output current is clamped at 3 A. This waveform is the TCKE805NA waveform. The waveform is clamped about 40ms, then the overheat protective operation is started, and then the auto-retry operation is repeated.

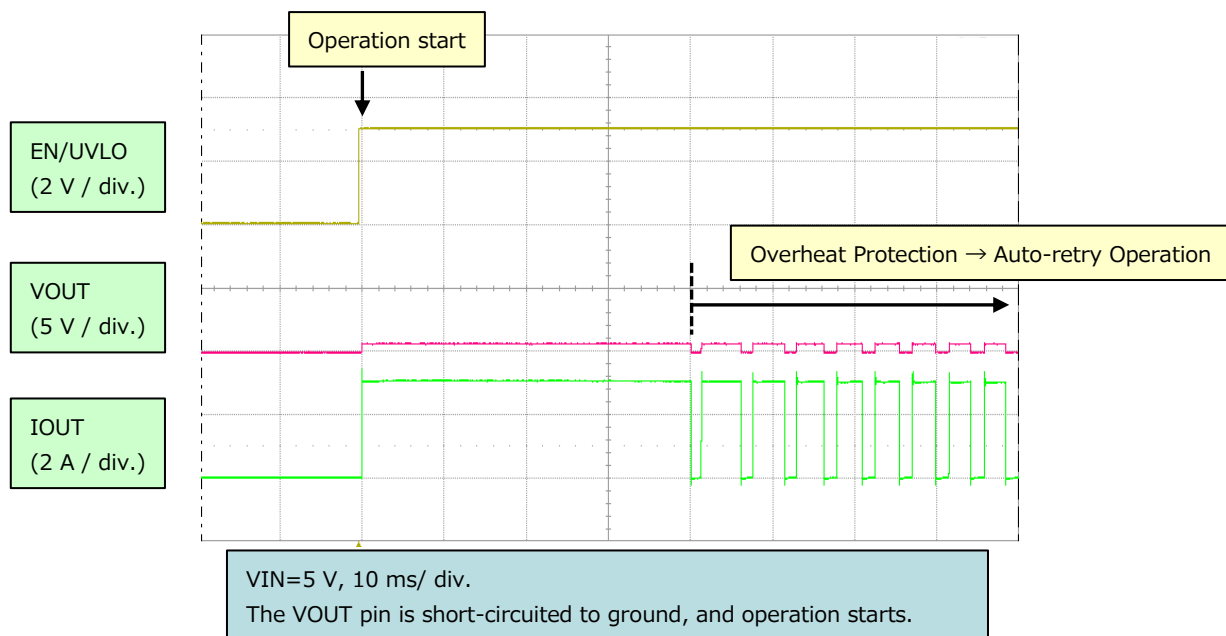

Fig. 5.1 Overcurrent protection operation waveform

5.2. Overvoltage protection function

Fig. 5.2 shows the overvoltage protection operation waveform. When the V_{IN} is changed from 5 V to 8 V under normal operating conditions. The V_{OUT} is clamped at 6.04 V even if V_{IN} rises to 8 V.

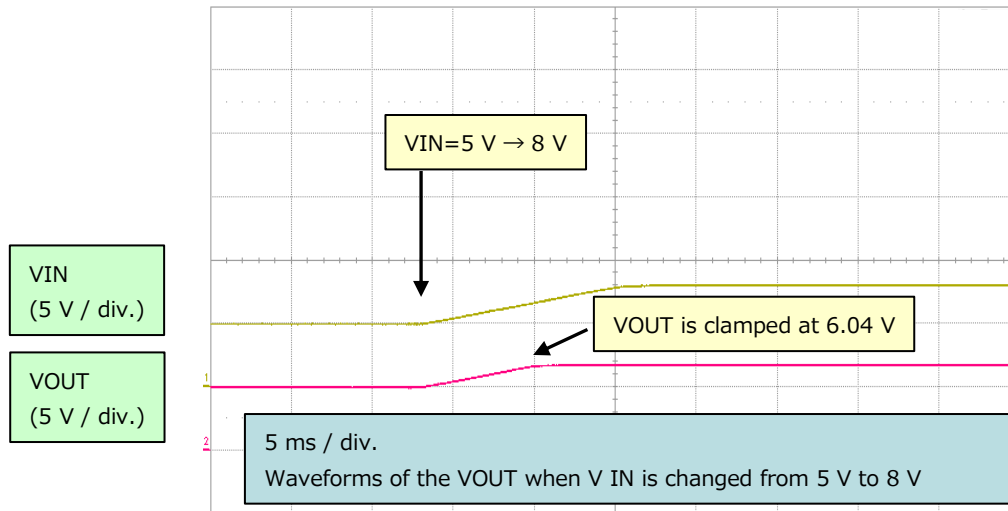

Fig. 5.2 Overvoltage protection operation waveform

5.3. Inrush current suppression function

Fig. 5.3 shows the operating waveforms of the inrush current suppression function. The rise time deviates from the calculated value (about 0.6 ms) based on the external constant of this application circuit due to the influence of the parasitic capacitance of the circuit board and the individual difference of the product used for actual measurement.

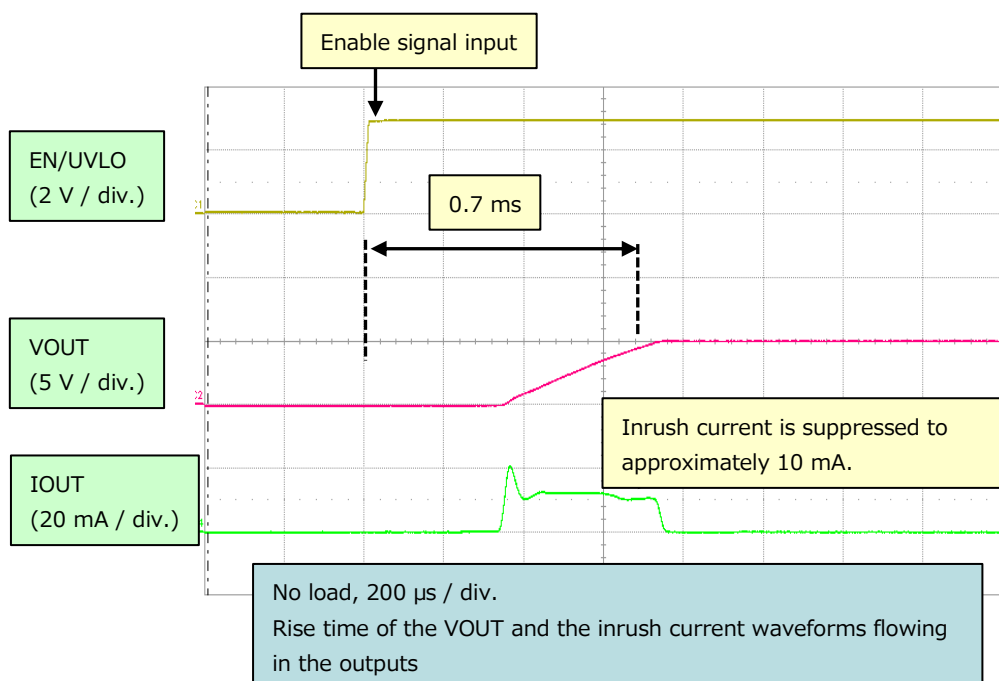

Fig. 5.3 Inrush current suppression operation waveform

Terms of Use

This terms of use is made between Toshiba Electronic Devices and Storage Corporation ("We") and customers who use documents and data that are consulted to design electronics applications on which our semiconductor devices are mounted ("this Reference Design"). Customers shall comply with this terms of use. Please note that it is assumed that customers agree to any and all this terms of use if customers download this Reference Design. We may, at its sole and exclusive discretion, change, alter, modify, add, and/or remove any part of this terms of use at any time without any prior notice. We may terminate this terms of use at any time and for any reason. Upon termination of this terms of use, customers shall destroy this Reference Design. In the event of any breach thereof by customers, customers shall destroy this Reference Design, and furnish us a written confirmation to prove such destruction.

1. Restrictions on usage

1. This Reference Design is provided solely as reference data for designing electronics applications. Customers shall not use this Reference Design for any other purpose, including without limitation, verification of reliability.
2. This Reference Design is for customer's own use and not for sale, lease or other transfer.
3. Customers shall not use this Reference Design for evaluation in high or low temperature, high humidity, or high electromagnetic environments.
4. This Reference Design shall not be used for or incorporated into any products or systems whose manufacture, use, or sale is prohibited under any applicable laws or regulations.

2. Limitations

1. We reserve the right to make changes to this Reference Design without notice.
2. This Reference Design should be treated as a reference only. We are not responsible for any incorrect or incomplete data and information.
3. Semiconductor devices can malfunction or fail. When designing electronics applications by referring to this Reference Design, customers are responsible for complying with safety standards and for providing adequate designs and safeguards for their hardware, software and systems which minimize risk and avoid situations in which a malfunction or failure of semiconductor devices could cause loss of human life, bodily injury or damage to property, including data loss or corruption. Customers must also refer to and comply with the latest versions of all relevant our information, including without limitation, specifications, data sheets and application notes for semiconductor devices, as well as the precautions and conditions set forth in the "Semiconductor Reliability Handbook".
4. When designing electronics applications by referring to this Reference Design, customers must evaluate the whole system adequately. Customers are solely responsible for all aspects of their own product design or applications. WE ASSUME NO LIABILITY FOR CUSTOMERS' PRODUCT DESIGN OR APPLICATIONS.
5. No responsibility is assumed by us for any infringement of patents or any other intellectual property rights of third parties that may result from the use of this Reference Design. No license to any intellectual property right is granted by this terms of use, whether express or implied, by estoppel or otherwise.
6. THIS REFERENCE DESIGN IS PROVIDED "AS IS". WE (a) ASSUME NO LIABILITY WHATSOEVER, INCLUDING WITHOUT LIMITATION, INDIRECT, CONSEQUENTIAL, SPECIAL, OR INCIDENTAL DAMAGES OR LOSS, INCLUDING WITHOUT LIMITATION, LOSS OF PROFITS, LOSS OF OPPORTUNITIES, BUSINESS INTERRUPTION AND LOSS OF DATA, AND (b) DISCLAIM ANY AND ALL EXPRESS OR IMPLIED WARRANTIES AND CONDITIONS RELATED TO THIS REFERENCE DESIGN, INCLUDING WARRANTIES OR CONDITIONS OF MERCHANTABILITY, FITNESS FOR A PARTICULAR PURPOSE, ACCURACY OF INFORMATION, OR NONINFRINGEMENT.

3. Export Control

Customers shall not use or otherwise make available this Reference Design for any military purposes, including without limitation, for the design, development, use, stockpiling or manufacturing of nuclear, chemical, or biological weapons or missile technology products (mass destruction weapons). This Reference Design may be controlled under the applicable export laws and regulations including, without limitation, the Japanese Foreign Exchange and Foreign Trade Law and the U.S. Export Administration Regulations. Export and re-export of this Reference Design are strictly prohibited except in compliance with all applicable export laws and regulations.

4. Governing Laws

This terms of use shall be governed and construed by laws of Japan.