

# **Motor Control Circuit for Cordless Power Tool**

# **Design guide**

**RD166-DGUIDE-01**

---

**TOSHIBA ELECTRONIC DEVICES & STORAGE CORPORATION**

## Table of Contents

<b>1. Introduction .....</b>	<b>3</b>
<b>2. Overview of MOSFET and Circuits .....</b>	<b>4</b>
2.1. MOSFET.....	4
2.2. Circuits.....	8
<b>3. Circuit Design .....</b>	<b>10</b>
3.1. Specifications.....	10
3.2. Operation and Setting .....	10
3.2.1 Motor Input Voltage Detector.....	10
3.2.2 Motor Current Detection Circuit.....	11
3.2.3 Error Detection Circuit .....	15
3.2.4 Standby Power Reduction Circuit (Self-Power Off Circuit).....	16
3.3. Notes for Circuit Design.....	17
<b>4. Board Design .....</b>	<b>18</b>
4.1. Example of Board Pattern.....	18
4.2. Notes for Board Design .....	20
<b>5. Product Overview .....</b>	<b>21</b>
5.1. TPH1R204PB.....	21
5.2. Other Products .....	22

## 1. Introduction

In recent years, the power tool market grows faster than manual tools due to expanded infrastructure in developing countries and an increase in the number of Sunday carpenters (DIY). Power tool sales are expected to reach \$46.5 billion in 2025, compared with about \$27.6 billion worldwide in 2015 (according to Future Market Insights data).

In recent years, advances in battery technology have made power tools lighter, more efficient, and longer operating times. This improves usability, portability, and safety, and leads to a major shift from AC plug type to cordless power type. In addition, the number of motors are increasing from brushed motors to high-power, highly efficient brushless DC motors (hereinafter referred to as "BLDC motors"). For these cordless power tools, it is important to design motors and their drive circuits that efficiently convert the battery's electrical energy into mechanical energy.

Toshiba have a broad lineup of low-loss, small package MOSFET products suit driving motors with cordless power tools that have limited battery capacities, allowing users to choose the best products for their applications. This Design Guide (hereinafter referred to as "this guide") describes the design of three-phase BLDC motor drive circuits for cordless power tools using N-channel power MOSFET TPH1R204PB ( $V_{DSS} = 40\text{ V}$ ) with U-MOS IX-H technologies to achieve low on-resistance and low spiking voltages. Six pieces of TPH1R204PB are used here and this product uses SOP Advance package (5 mm x 6 mm) to help make the board and equipment more compact.

In the motor drive circuit (hereinafter referred to as "this circuit") described in this guide, two types of drive methods, square wave drive and sine wave drive, are switchable to understand the operation. However, there is no need to switch the drive method with the actual power tool. Therefore, when designing the actual application by applying the circuit of this guide, select the appropriate drive method for either of them considering the application and usage environment, etc. Rotation speed and torque can be controlled in either method. For this control and other purposes, the circuit for detecting the motor current is a three-shunt system, and it can also support sensor-less control.

Please refer to this guide as an aid in designing motor-driven circuits for cordless power tools using our power MOSFET.

## 2. Overview of MOSFET and Circuits

### 2.1. MOSFET

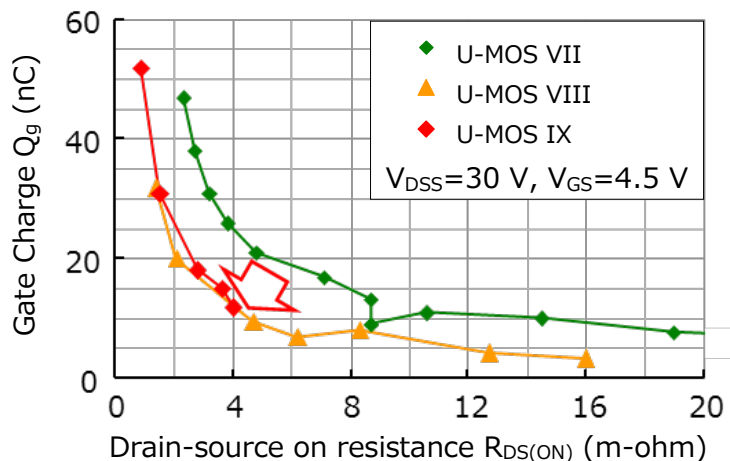
While cordless power tools are powered by batteries, it is natural for power tool to be demanded more compact and long-life operation.

The mainstream of batteries used in cordless power tools shifts from nickel-cadmium batteries to nickel-metal hydride batteries and lithium-ion batteries in response to the conflicting demands of long-life operation (increased battery capacity) and compact size. On the other hand, in response to these demands, not only the battery-side approach but also the circuit side that drives the motor converting electrical energy into mechanical energy is required to take approaches such as improving efficiency and compact size of the board.

With this background, a low-loss and small package power MOSFET suits as a motor drive device for cordless power tools. We are developing U-MOS series of low-voltage MOSFET products with trench processes that meet these requirements. In the newest generations, we are developing U-MOS VIII series which supports a wide range of rated voltages from 30 to 250 V, and U-MOS IX series which realizes low on-resistance in the 30 to 100 V voltage range. We offer a wide range of products with different specifications, so you can choose the best product according to individual applications and specifications.

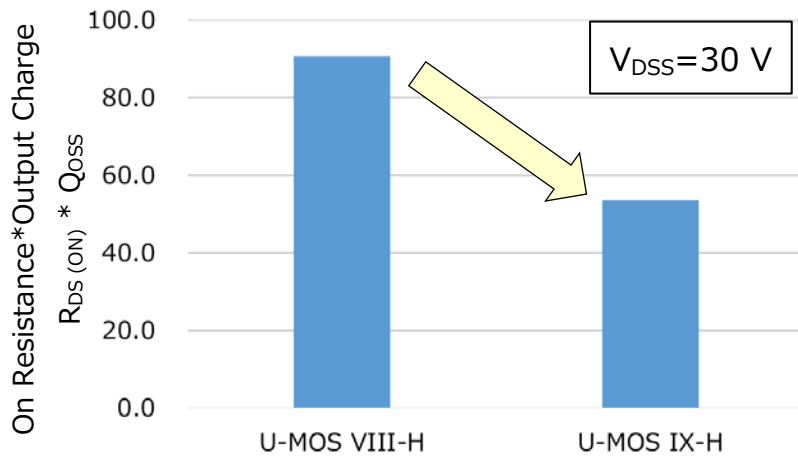
These series have been developed with an emphasis on reducing losses generated by MOSFET. In order to reduce the switching loss that occurs when switching the operating MOSFET during a switching, the gate charge ( $Q_g$ ) is kept small. In addition, the drain-source on resistance ( $R_{DS(ON)}$ ), which causes conduction loss and wasteful heat when current is flowing through MOSFET, is also kept small. The  $R_{DS(ON)}$  is a trade-off with  $Q_g$ , but is improving over time.

Fig.2.1 shows a chart of the results of comparing  $Q_g$  and  $R_{DS(ON)}$  with the previous series U-MOS VII series.



**Fig.2.1 Gate Charges and On-Resistance for U-MOS Series**

In addition, the newest U-MOS IX-H series reduces the reverse recovery loss by reducing the output charge ( $Q_{oss}$ ) that directly affects the reverse recovery operation. Fig.2.2 shows comparison of the on resistance and the output charge between U-MOS IX and U-MOS VIII-H series.

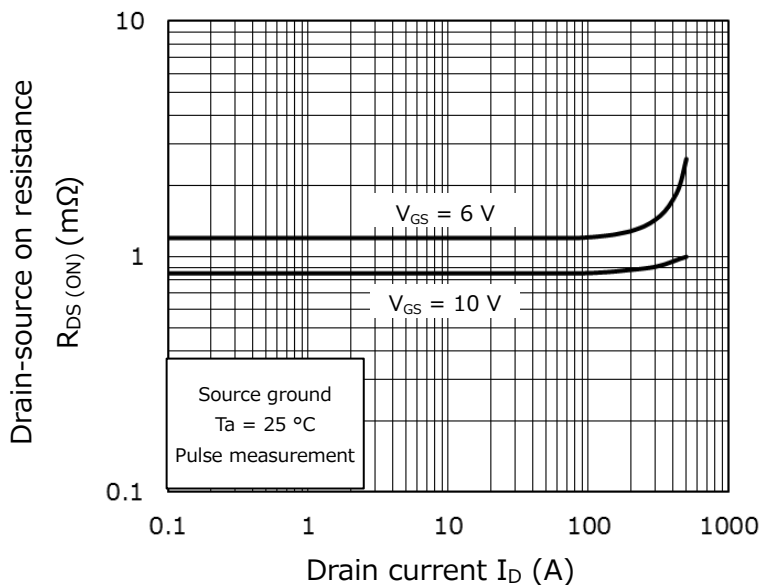


**Fig.2.2 Comparison of On Resistance and Output Charge among U-MOS Series**

In this guide, BLDC motor drive circuits were designed by selecting U-MOS IX-H series MOSFET TPH1R204PB for output stage.

The operating power supply voltage range of this circuit is assumed to be 12 to 24 V to accommodate the voltage of 18 to 21 V, which has been increasing in recent years, in addition to the conventional 12 V battery for cordless power tools. However, we have chosen this product with drain-source voltage ( $V_{DSS}$ ) of 40 V from U-MOS XIII series and U-MOS IX series considering the surge voltage during switching, etc.

Fig.2.3 shows the on-resistance and drain current characteristics of TPH1R204PB.



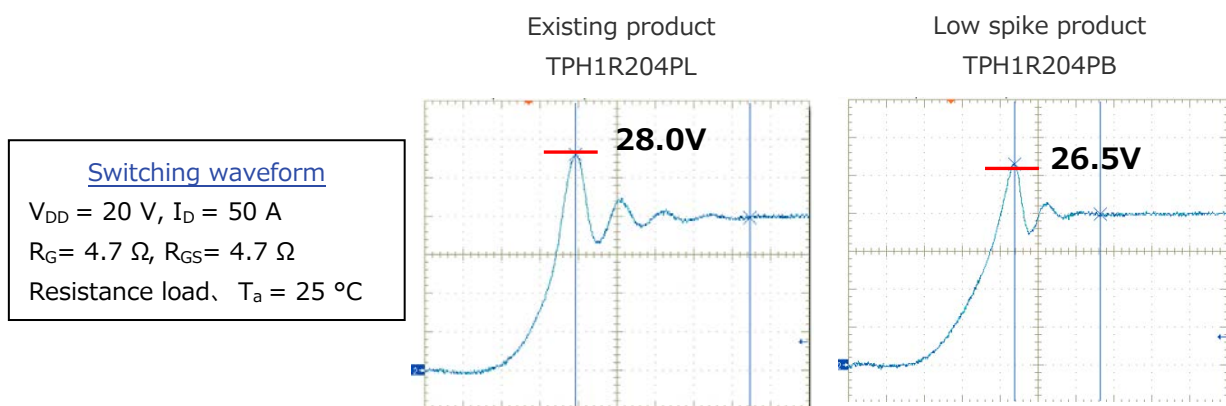
**Fig.2.3 TPH1R204PB On-Resistance-Drain Current Characteristics**

The drain-source On Resistance ( $R_{DS(on)}$ ) is 0.85 mΩ ( $V_{GS}=10 V, I_D=50 A$ , typical) and enclosed in a small package (SOP Advance) for ease of thermal and structural design and long battery life, making it suit for compact cordless power tools.

One of the reasons for choosing this product is that TPH1R204PB optimizes the internal gate resistance ( $r_g$ ) and parasitic snubber circuit by improving the surface patterns of the device for the existing product TPH1R204PL, and is a low spike-resistant product that reduces the spike-voltage generated during switching. The on resistance is also lower than TPH1R204PL.

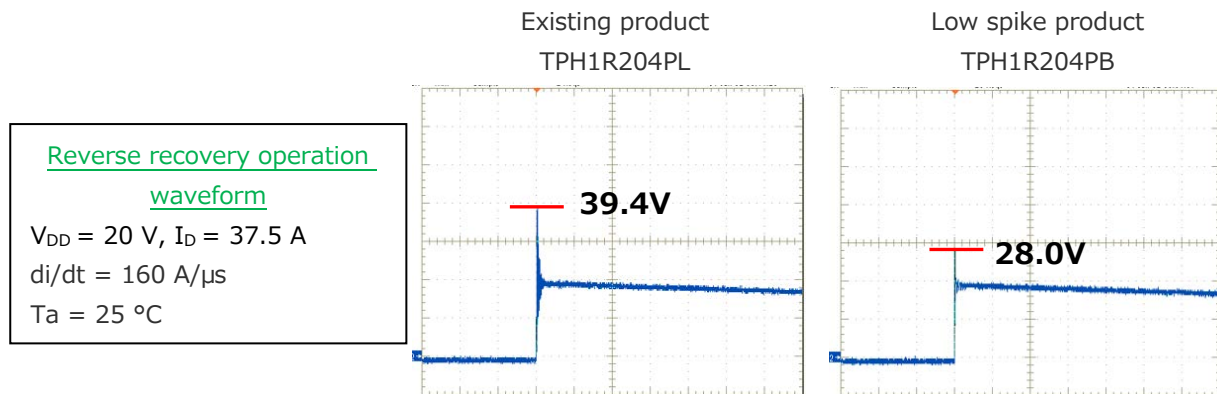
Motor drive circuits for power tools described in this guide are for driving three-phase BLDC motors. Generally, MOSFET switching required to drive three-phase BLDC motors generates spiking voltages when the motor is turned off. In TPH1R204PB, this spike-voltage is reduced and ringing converges faster than existing products due to improvements in the internal gate-resistance, etc. As a result, the use of a TPH1R204PB reduces the EMI generated by cordless power tools and the spike voltages applied to the batteries, and contributes to system stabilization.

Fig.2.4 shows comparison the switching spike voltage.



**Fig.2.4 Spike Voltages Comparison**

Fig.2.5 shows comparison the spiking voltages in the reverse-recovery operation of the body diodes inside MOSFET with those of the standardized products.



**Fig.2.5 Spike Voltage Comparison in Reverse Recovery Operation**

In the three-phase BLDC motor drive of a cordless power tool, spiking voltages may occur during reverse recovery operation due to the influence of the inductance of the motor load. In TPH1R204PB, the parasitic snubber circuits inside MOSET contributes for reducing spike voltages during reverse recovery operation and converges ringing faster than existing products.

For further TPH1R204PB, please refer to the data sheet of the link destination below.

To download the TPH1R204PB datasheet →

[Click Here](#)

**2.2. Circuits**

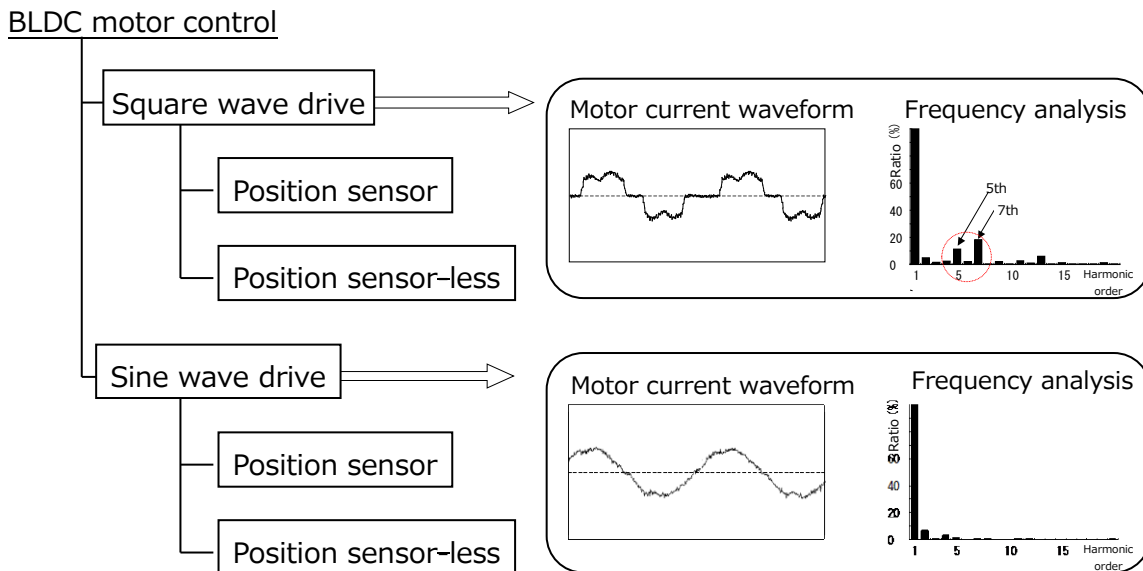
There are two types of drive methods for three-phase BLDC motors:

1. Square wave drive
2. Sine wave drive

depending on the waveform of the motor current. In both cases, a constant rotational force is obtained by detecting the rotational position of the motor and switching the direction in which the current flows accordingly.

Sine wave drive is superior in terms of control accuracy, efficiency, and noise, but the system becomes complicated and expensive. On the other hand, square wave drive is inferior to control accuracy and efficiency and noise against sign wave drive, but the system is simple and low cost operation.

Both drive methods require the detection of the motor position in order to switch the direction of the current flowing through the coil of the motor. There are two methods for position detection: control with a position sensor and position sensorless.



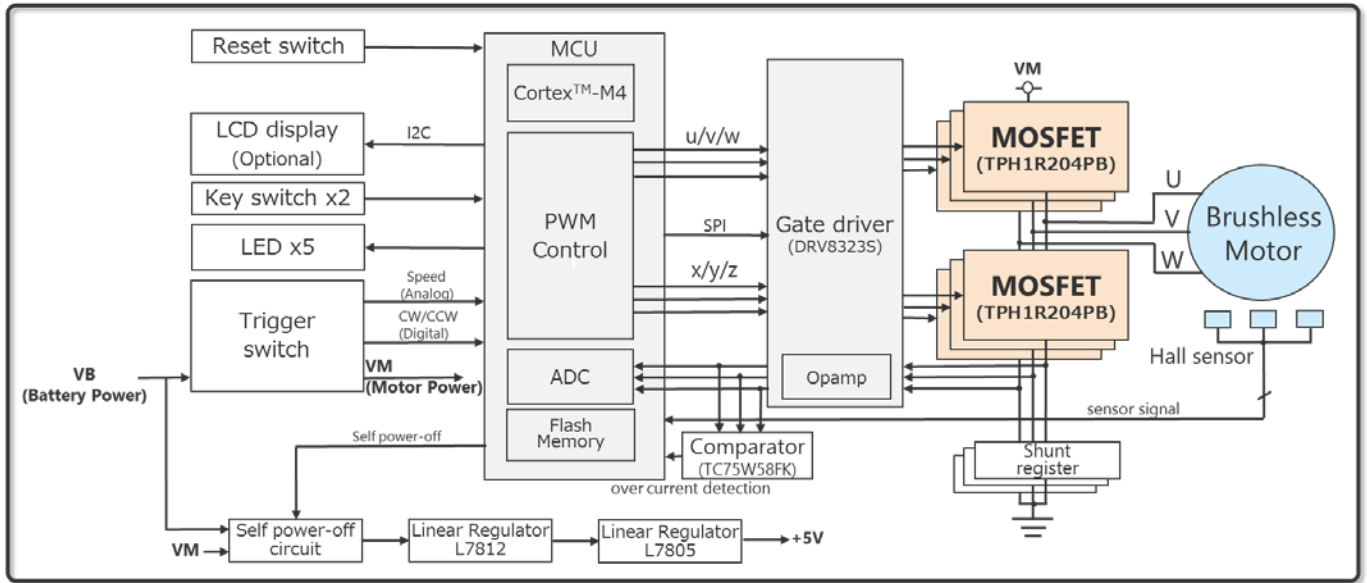
**Fig.2.6 Control method of BLDC motors**

The control with position sensor is a motor control method using a sensor that detects the rotation speed and rotation position of the motor. Since the motor position detection at startup can be accurately performed, torque can be output from low speed. However, the mounting position accuracy of sensors such as Hall sensors and encoders must be taken into consideration. Wiring of the sensor signal output from the motor is also required.

On the other hand, position sensorless control is easy to deal with motors that cannot physically place sensors inside and motors that are exposed to poor environments, and it is possible to simplify the structure of the motors, but it has the disadvantage that it is difficult to produce torque at low speeds because it is impossible to perform motor position detection at startup.



Fig.2.7 shows the system block diagram of this circuit.



**Fig.2.7 Motor Drive Circuit System Block Diagram**

A total six of TPH1R204PB MOSFETs are used on the upper and lower sides of each phase to drive the U, V, and W phases of the motor. These MOSFETs are driven by a gate driver DRV8323S manufactured by Texas Instruments.

This circuit is controlled with a position sensor using a Hall sensor so that both square wave drive and sine wave drive can be selected. Rotation speed and torque can be controlled by MCU in either method. The drive system can also be switched by the MCU so that the operation status of the motor can be checked on the display.

As described, the square wave drive and sine wave drive have advantages and disadvantages. In an actual power tool, it is not necessary to select the drive method, but it is common to select either from the environment in which the power tool is used or from the specifications. However, for the purpose of explanation in this guide, both methods can be selected.

The motor current detection used for controlling the rotational speed and torque is a three-shunt method that can detect the current of each phase separately, and it is also possible to support sensorless control.

In addition, the PCB consists of two interface boards, one is a main board containing TPH1R204PB and MCUs, and the other is an interface board that connects peripheral components such as displays and switches, taking into account the sizes and spaces of the power tool enclosure.

For details of the circuit, refer to the schematics provided in the reference design.

### 3. Circuit Design

#### 3.1. Specifications

Table3.1 shows the main specifications of motor drive circuit.

**Table3.1 Main Specifications**

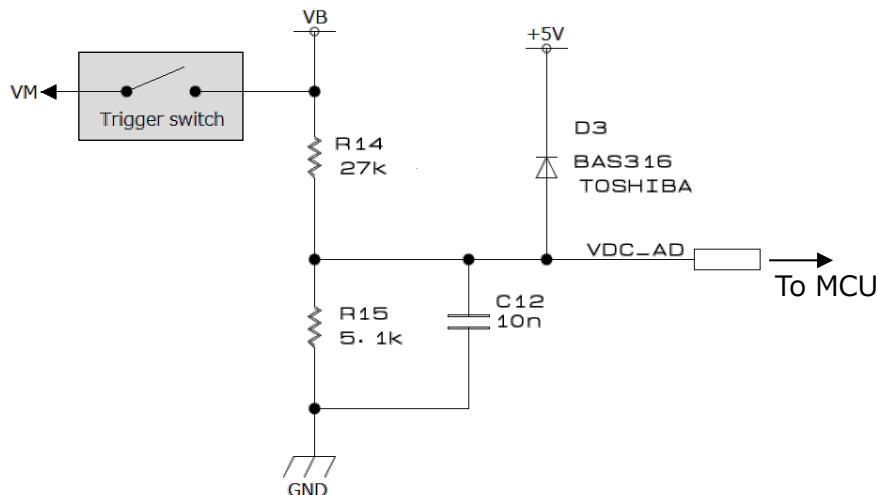
Item	Value	Unit
Input voltage	12~24	V
Output power	200	W
Average current	±20	A
Maximum peak current	±60	A
Switching frequency	20	kHz
Driving system	Square wave and Sine wave drive with position sensors	

#### 3.2. Operation and Setting

##### 3.2.1 Motor Input Voltage Detector

The entire motor drive circuit is controlled by the MCU, but the voltage applied to the motor via the upper MOSFET of each U, V, and W phase is an important factor for motor control. The MCU constantly monitors the voltage (VM) to which the drain of each phase upper MOSFET is connected as the voltage applied to the motor, and is used for various control and step-out avoidance, etc.

Fig.3.1 shows the motor input detection circuit. This circuit detects the battery voltage (VB) by dividing the voltage directly with resistors R14 and R15. The VM is supplied from VB voltage directly via the trigger switch.

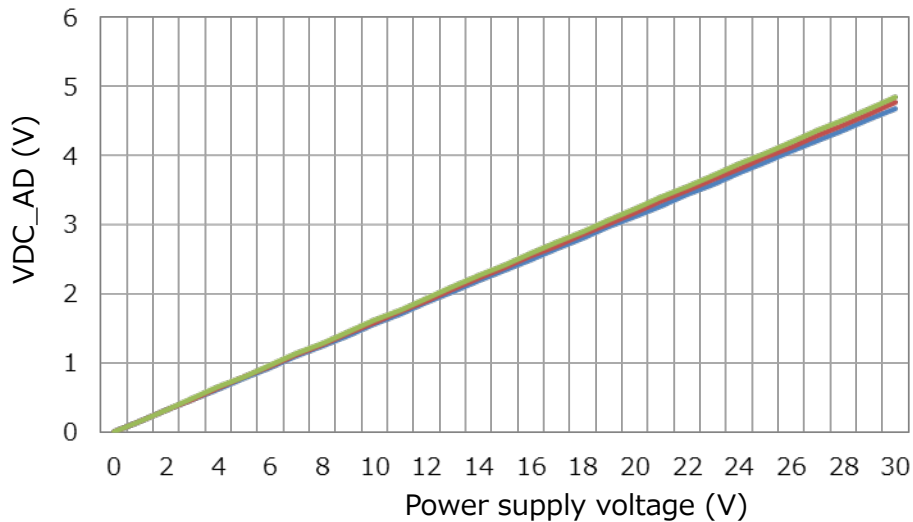


**Fig.3.1 Motor Input Voltage Detector**

The voltage VDC\_AD input to the MCU as the detection voltage is calculated by the following equation:

$$VDC\_AD = \frac{R15}{R14 + R15} \times VB$$

Resistance errors must also be taken into account because resistance dividers are adopted. Fig.3.2 shows VDC\_AD error distribution graph when a resistance of 1% tolerance is selected.

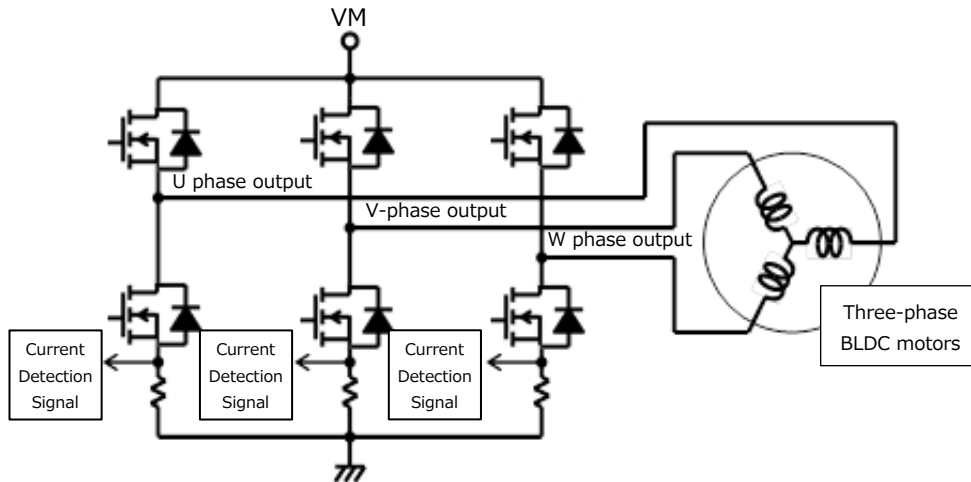


**Fig.3.2 VDC\_AD Error Distribution**

### 3.2.2 Motor Current Detection Circuit

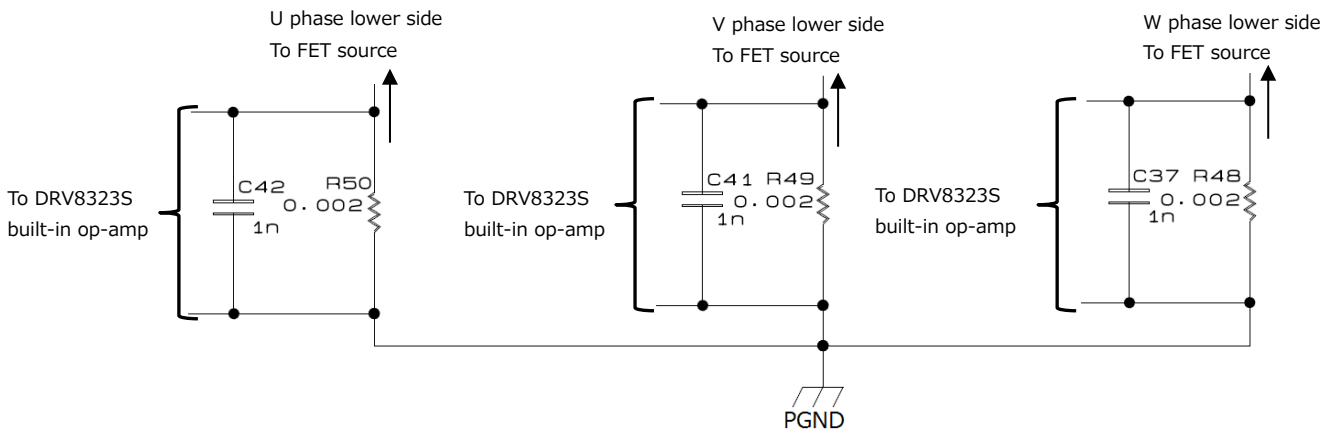
The current detector for controlling the motor and protecting the motor in the event of an error is a three-shunt system in which a shunt resistor is externally connected to the source of the lower MOSFET of the U, V, and W phases. The voltages generated by the respective shunt resistors due to the motor currents in each phase are amplified by an amplifier with a built-in gate driver DRV8323S and input to the MCU's AD converter, which is used as signals for controlling the motor rotations and torques generation. Each of these signals is also input to a comparator and compared to a reference voltage. If a certain current flows and the current detection signal exceeds the reference voltage, an error is judged and a signal is sent to the MCU to perform the protection operation.

Fig. 3.3 shows the circuit diagram of each phase output of the 3 shunt method.



**Fig.3.3 3 Shunt Method**

Install a shunt resistor between the lower MOSFET of each phase and the GND. Fig.3.4 shows the shunt resistor circuit. The voltages generated across the current sensing resistors (R48, R49, R50) located between the lower MOSFET sources of each phase and GND detect the current of each phase.



**Fig.3.4 3 Shunt Resistance Circuit**

If the resistance value of the current detection resistor is set to a large value, the level of the detection signal will also increase, enabling high-precision detection of the current. On the other hand, because the power dissipation ( $I^2R$ ) also increases, a resistor with a higher allowable power, i.e. a larger resistor, should be used. This may not be acceptable for applications requiring miniaturization and space saving. When the value of the current detection resistor is decreased, the level of the detection signal is reduced so it is susceptible to errors due to parasitic resistance of wiring and printed circuit board wiring and jump noise etc., but because the power consumption is reduced, a resistor with a low allowable power and a small size can be used.

In this circuit, a small value of resistance is selected from the advantages and required accuracy of system miniaturization, considering the application for power tools.

The motor current is generally assumed to be  $\pm 20$  A in static operation and  $\pm 40$  A in transient operation, depending on the size of the motor used in the power tool. From this current value, power

consumption, and part size, the detection resistance was determined to be a resistance of 2 mΩ and an allowable power of 3 W.

Since the signal generated by the current detection resistor is very small level (maximum of ±80 mV when transient) and difficult for MCU to measure directly, signal amplification by an op-amp, etc. is required. In addition, since the current flowing through the three-phase BLDC motor is bi-directional, both positive and negative voltages are generated at both ends of the current detection resistor. However, since the positive voltage is required for the input signal to the MCU, the level must be shifted by applying an offset so that a bidirectional current can be detected.

In this circuit, the internal amplifier of the gate driver DRV8323S is used for the amplifier op-amp, and the output is offset internally in DRV8323S.

The gain of the amplifier and the offset voltage to be applied are set so that the amplitude of the level-shifted signal, which amplifies the voltage generated by the detection resistance by the motor current, is within the linear range of the AD converter characteristic of the MCU built-in. In this circuit, a margin is set to the transient operating current ±40 A of the motor so that the amplitude is full of the MCU's AD converter input full range when ±60 A flows.

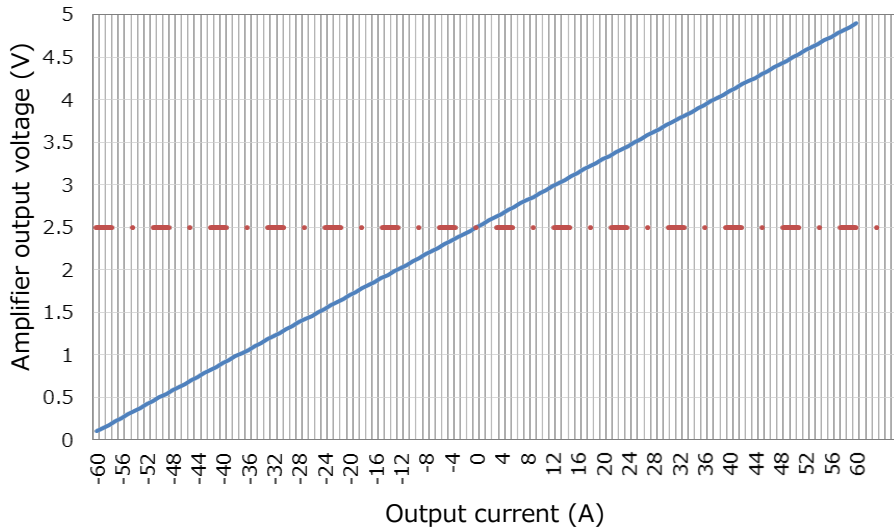
The MCU operates with 5 V power supply, so the AD converter input amplitude range is 0 to 5 V. Therefore, the applied offset voltage is 2.5 V so that the signal is amplitude about 2.5 V of this half.

Gain is also set so that the maximum amplitude of the signal falls within this range. Because the current detection resistance is 2 mΩ, a maximum voltage of ±120 mV is generated when a current of ±60 A flows. Since the input range of the AD converter is maximum amplitude ±2.5 V at the center value of 2.5 V as described above, the maximum input amplitude of the AD converter is divided by the maximum amplitude of the detected voltage to obtain the following values:

$$\frac{2.5}{120 \times 10^{-3}} \cong 20.8$$

From this result, we set the gain to 20 times (=10 dB).

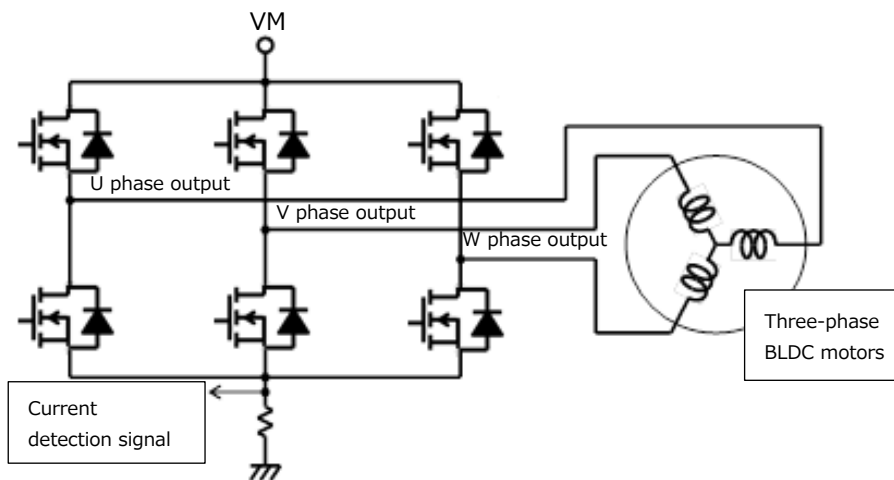
Fig.3.5 shows the relationship between the current flowing through the output current detection resistor and the amplifier output voltage. The outputs of the amplifiers increase by more than 2.5 V for positive differential signals and decrease by less than 2.5 V for negative differential signals.



**Fig.3.5 Relationship between Output Current and Amplifier Output Voltage**

(Reference)

The lower MOSFET of each phase can be sourced and the phase currents can be combined into a 1 shunt method that is less expensive to configure. Fig.3.6 shows the connection in this case.



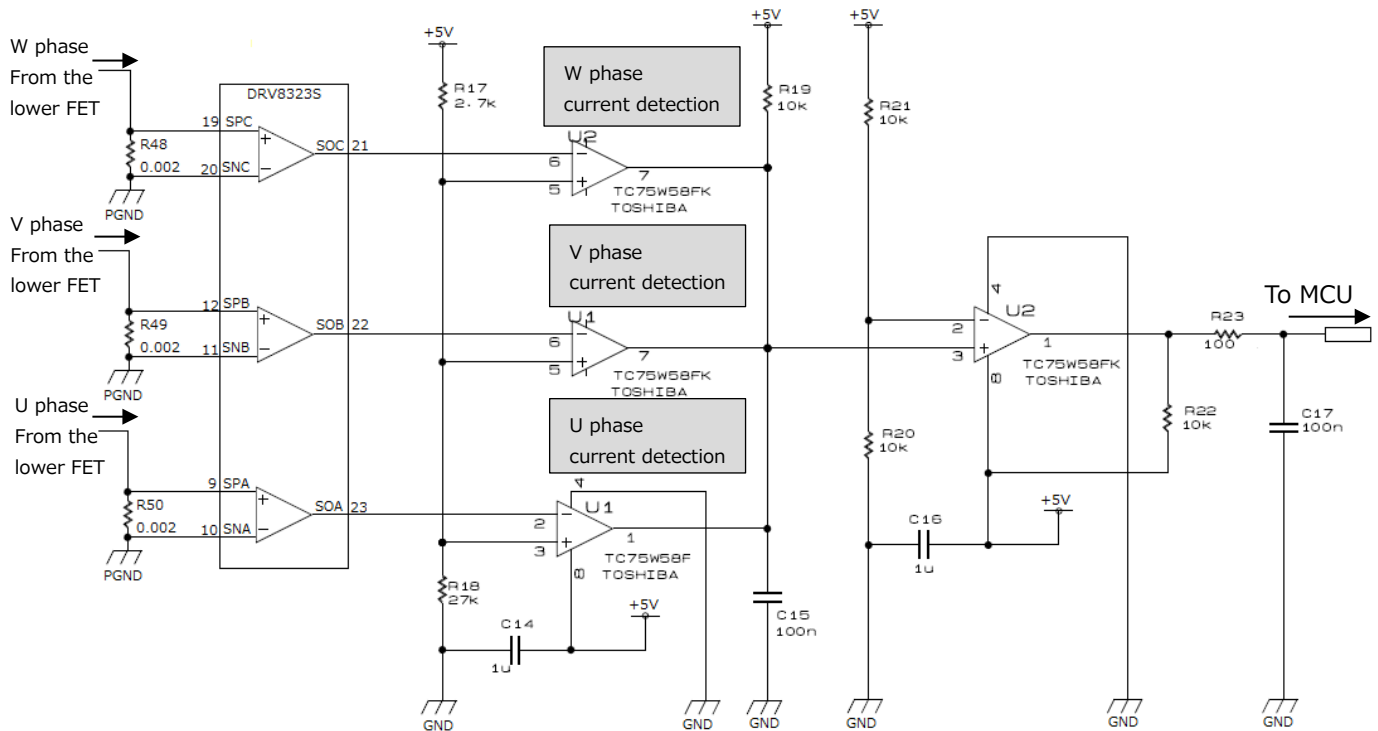
**Fig.3.6 1 Shunt Method**

A shunt resistor is installed in series with the GND line, and its voltage value is measured by the A/D converter of the MCU. As with the 3 shunt method, amplification by an op-amp and level shift by an offset circuit are required.

Note that this board has 3 shunt system, so it can accommodate sensorless control that calculates the rotation position by calculation estimation of the MCU using various parameters of the motor current, voltage, and motor instead of the sensor. This is a kind of sensorless control, and it can also support vector control used in applications requiring more precise control.

### 3.2.3 Error Detection Circuit

When the MCU detects the EMG (emergency) signal, the error detection circuit operates to shut off the output and perform the protection operation. Fig.3.7 shows the error detection circuit.



**Fig.3.7 Error Detection Circuit**

The current detection signal amplified by the built-in amplifier of the gate driver is also input to the comparator for each phase. If any one of them exceeds the reference voltage, an error is judged and an EMG signal is output to the MCU. The MCU receives the signal and turns off MOSFET control signal output of the gate driver, stops operation, and cuts off the output. The MCU is judged to be abnormal when the EMG signal is at the low level.

In this circuit, the threshold ( $V_{EMG}$ ) of the current to be judged as abnormal is 50 A. The voltage value of the corresponding current detection signal is determined by the following equation, in which the power supply voltage 5 V is divided by the resistors R17 and R18.

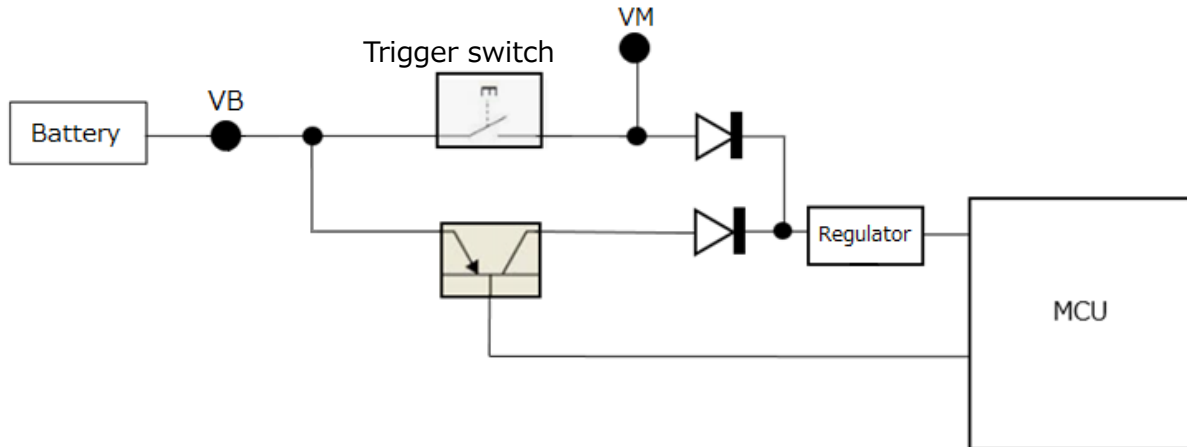
$$V_{EMG} = \frac{R18}{R17 + R18} \times 5 (V) = \frac{27 \times 10^3}{2.7 \times 10^3 + 27 \times 10^3} \cong 4.55 (V)$$

When the voltage of the signal amplified by the amplifier of the current detection signal of each phase exceeds this value, it is judged as abnormal current. For the relationship between this voltage and the current of each phase, refer to the graph in Fig.3.5 in the previous section.

### 3.2.4 Standby Power Reduction Circuit (Self-Power Off Circuit)

This circuit has a function to stop the power supply to the MCU in order to reduce the standby current. When the motor is not rotating for a certain period of time, the power is cut off by turning off the transistor that the MCU is controlling the power supply, and the power supply to the MCU is cut off. In this case, the MCU turns OFF when there is no current to the motor for 2 seconds or more. However, set an appropriate OFF time by software.

Fig.3.8 shows a block diagram of standby power reduction.

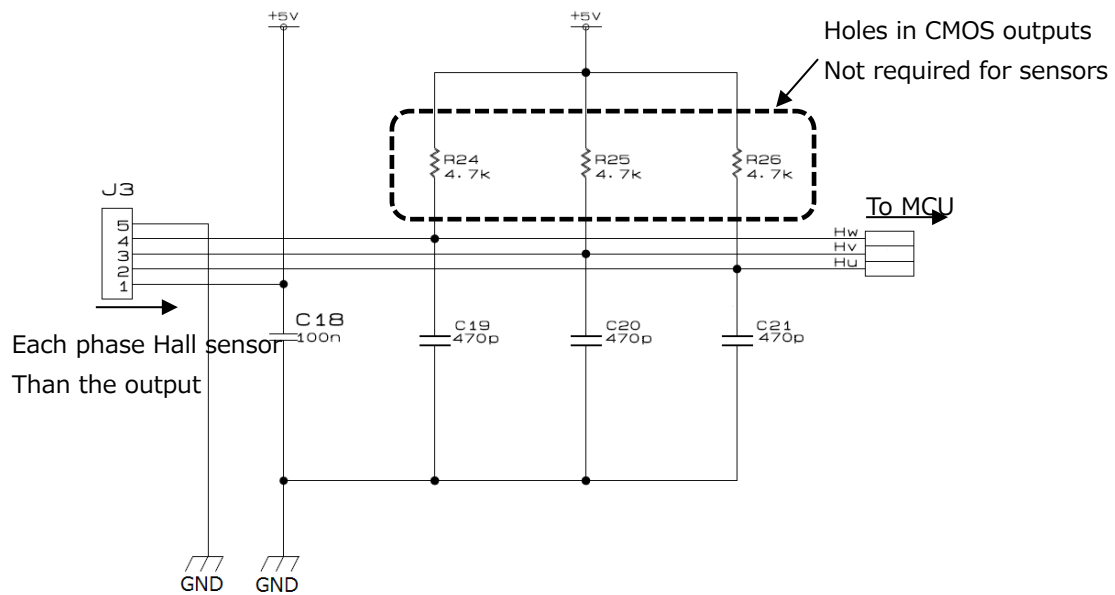


**Fig.3.8 Block Diagram of Standby Power Reduction**



**3.3. Notes for Circuit Design**

- The absolute maximum rating is a definition that does not exceed any one value of multiple ratings instantaneously. It cannot be exceeded for any of multiple ratings. Be careful to ensure the derating so that the absolute maximum ratings are not exceeded even during dynamic operation.
- The capacitance of the bypass capacitors C1 and C2 of the power supply is set to the capacitance value that is sufficient to match the board in this circuit. However, the capacitance required varies depending on the type of power supply, the wiring inductance of the power supply and motor drive circuit, the permissible supply voltage ripple, and the type of motor. Generally, the capacitor capacity is set with a margin, but the size of the parts also increases, resulting in the disadvantages of increased cost and increased proprietary area of the circuit board. Select the optimum capacitor capacity according to the circuit and environment to be actually used.
- In this circuit configuration, the Hall sensor output is assumed to be an open drain type. When using CMOS output types, the pull-up resistors R24, R25, and R26 are not required (Fig.3.9).



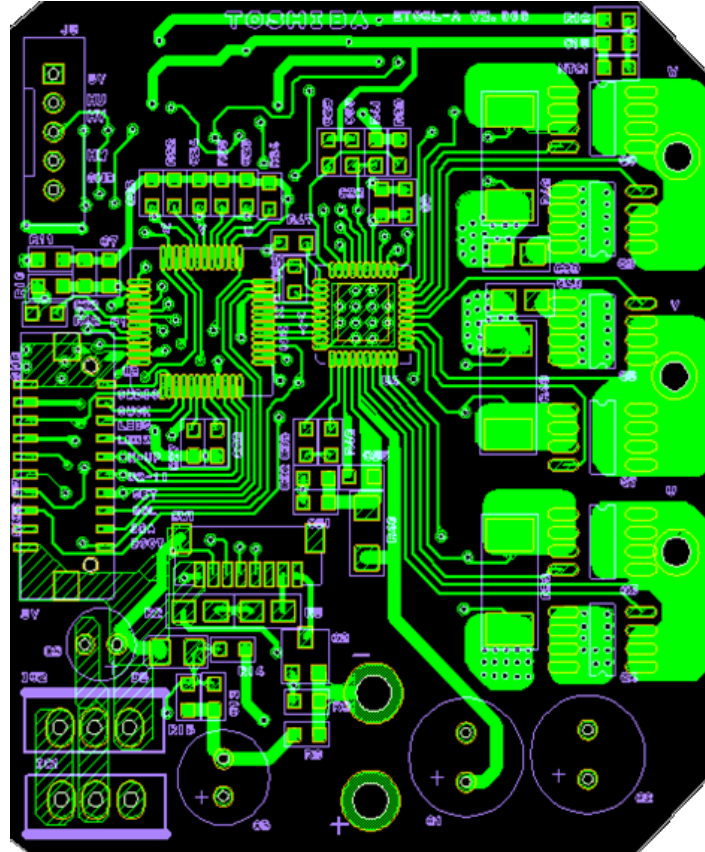
**Fig.3.9 Hall Sensor Output Circuit**

## 4. Board Design

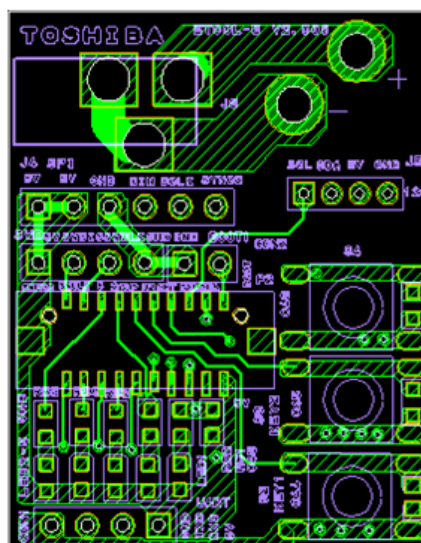
### 4.1. Example of Board Pattern

This section shows an example of the board pattern of this circuit.

Fig.4.1 and Fig.4.2 show the top side of board pattern on the main board and the interface board.

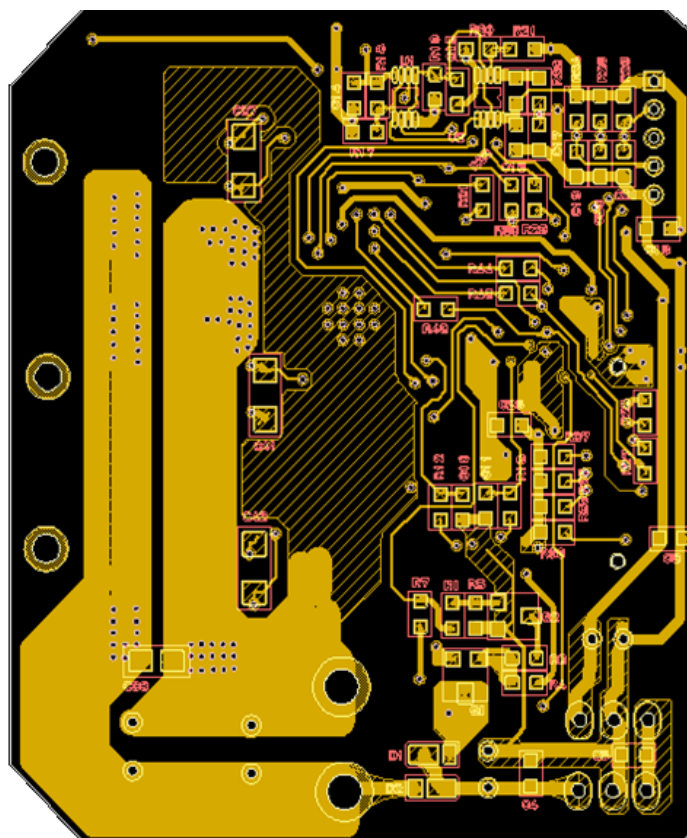


**Fig.4.1 Main Board Pattern (Top side)**

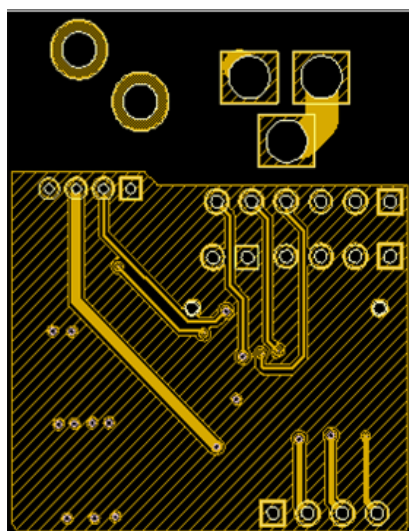


**Fig.4.2 Interface Board Pattern (Top side)**

Fig.4.3 and Fig.4.4 show the bottom side of board pattern on the main board and the interface board.



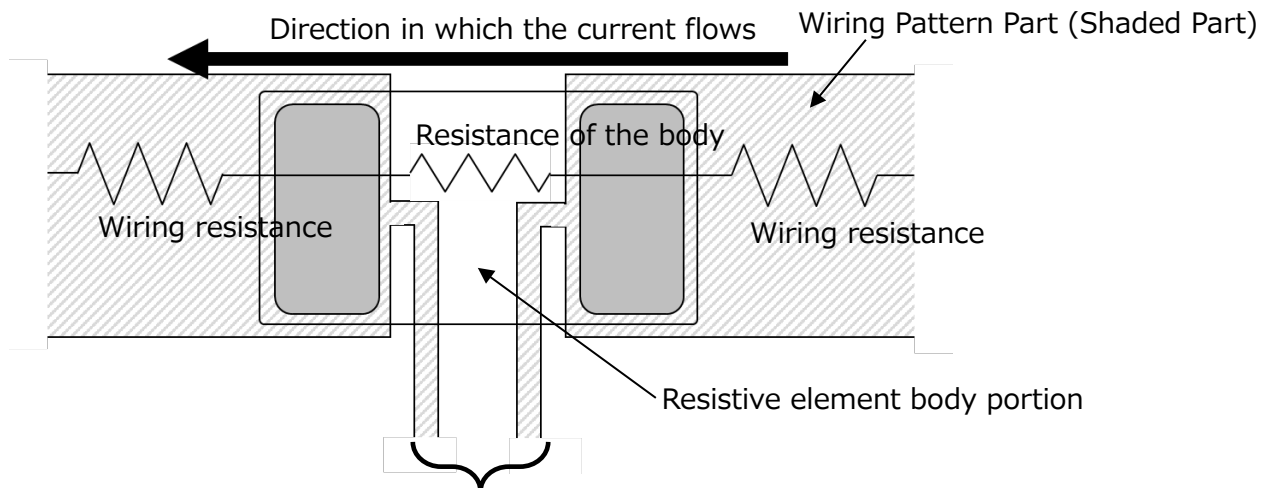
**Fig.4.3 Main Board Pattern (Bottom side)**



**Fig.4.4 Interface Board Pattern (Bottom side)**

## 4.2. Notes for Board Design

- The most important consideration is to ensure that the voltage drop of the shunt resistor used for current detection does not cause errors due to the resistance of the board pattern wiring. For this reason, the wiring to the current detection resistor should be completely separated from the wiring that flows the current and the wiring that detects the voltage drop at the land pattern of the resistor, and should be drawn out so that the voltage drop due to the wiring resistance does not enter the detection voltage. This enables accurate current detection, enabling high-precision motor control. This method of drawing out the wiring is called Kelvin connection. Fig.4.5 shows an image of the Kelvin connection pattern.



Detects only the voltage drop due to the resistance of the main unit.

**Fig.4.5 Wiring Diagram of Kelvin Connection**

- Wire the power supply, GND, and output of each phase around the motor as wide and thick as possible to reduce the wiring resistance. Also, as there is a possibility of picking up the noise, pay attention to the routing so that the pattern of the power supply and GND does not form a loop.
- GND of this circuit is divided into GND, PGND, AGND, etc. These GNDs are located at the root of the grounding part of the power supply bypass capacitors (C1 and C2) on the board, and the wiring should be divided for each GND to make the common impedance component as small as possible.
- In this circuit, bypass capacitors are also placed in the power supply pins of the gate driver DRV8323S (C31 and C32) and ICs such as the MCU (C22) and the drains (C38, C39, C40) of the upper power MOSFET of each phase output. Place these capacitors as close to the terminals as possible and use a type with good high frequency characteristics. Also, place the capacitors that are connected in parallel to the shunt resistor section as close to the shunt resistor as possible to minimize the resistance component that enters the capacitor in series.

## 5. Product Overview

This section provides an overview of the power MOSFET TPH1R204PB used in this circuit, as well as detailed links to our products.

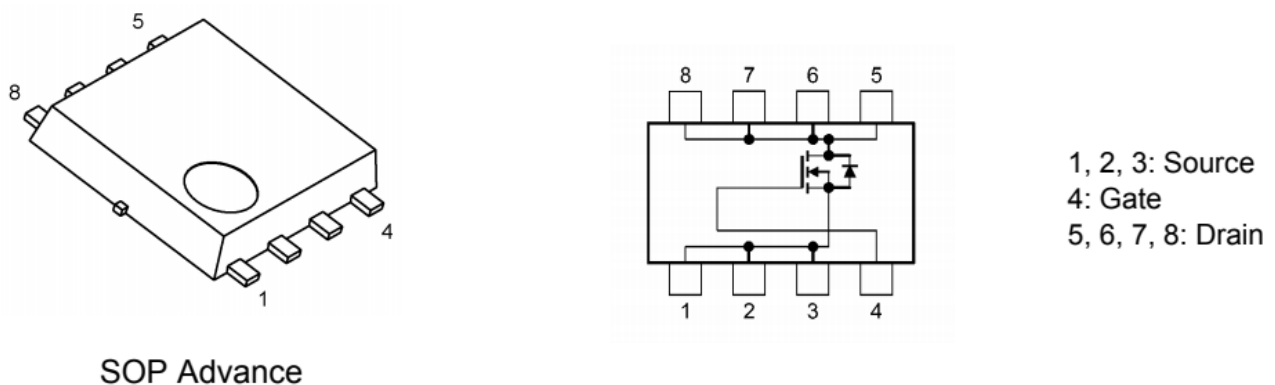
### 5.1. TPH1R204PB

N-channel MOSFET (U-MOS IX-H)

#### Features

- $V_{DSS}=40\text{ V}$ ,  $I_D=150\text{ A}$
- High speed switching
- Small gate-input charge:  $Q_{SW} = 21\text{ nC}$  (typical)
- Low power charge:  $Q_{OSS} = 56\text{ nC}$  (typical)
- Low on resistor:  $R_{DS(ON)} = 0.85\text{ m}\Omega$  (typical) ( $V_{GS} = 10\text{ V}$ )
- Lower leakage current:  $I_{DSS} = 10\text{ }\mu\text{A}$  (max) ( $V_{DS} = 40\text{ V}$ )
- Easy-to-use enhancement types:  $V_{th} = 2.0\text{ to }3.0\text{ V}$  ( $V_{DS} = 10\text{ V}$ ,  $I_D = 0.5\text{ mA}$ )

#### Appearance and Pin assignment



**Fig.5.1 Appearance and Pin assignment**

To download the TPH1R204PB datasheet →

[Click Here](#)

### 5.2. Other Products

In addition to TPH1R204PB, please refer to the data sheet of the link below for the detail of our products used in this circuit.

To download CMOS dual comparator TC75W58FK datasheet →

[Click Here](#)

To download Schottky Barrier Diode CUHS15F40 datasheet →

[Click Here](#)

To download switching diode BAS316 datasheet →

[Click Here](#)

To download PNP Power Transistor 2SA2056 datasheet →

[Click Here](#)

To download NPN Power Transistor 2SC6061 datasheet →

[Click Here](#)

To download transistors for Low Frequency Amplifiers TMBT3904 →

[Click Here](#)

## Terms of Use

This terms of use is made between Toshiba Electronic Devices and Storage Corporation ("We") and customers who use documents and data that are consulted to design electronics applications on which our semiconductor devices are mounted ("this Reference Design"). Customers shall comply with this terms of use. Please note that it is assumed that customers agree to any and all this terms of use if customers download this Reference Design. We may, at its sole and exclusive discretion, change, alter, modify, add, and/or remove any part of this terms of use at any time without any prior notice. We may terminate this terms of use at any time and for any reason. Upon termination of this terms of use, customers shall destroy this Reference Design. In the event of any breach thereof by customers, customers shall destroy this Reference Design, and furnish us a written confirmation to prove such destruction.

### 1. Restrictions on usage

1. This Reference Design is provided solely as reference data for designing electronics applications. Customers shall not use this Reference Design for any other purpose, including without limitation, verification of reliability.
2. This Reference Design is for customer's own use and not for sale, lease or other transfer.
3. Customers shall not use this Reference Design for evaluation in high or low temperature, high humidity, or high electromagnetic environments.
4. This Reference Design shall not be used for or incorporated into any products or systems whose manufacture, use, or sale is prohibited under any applicable laws or regulations.

### 2. Limitations

1. We reserve the right to make changes to this Reference Design without notice.
2. This Reference Design should be treated as a reference only. We are not responsible for any incorrect or incomplete data and information.
3. Semiconductor devices can malfunction or fail. When designing electronics applications by referring to this Reference Design, customers are responsible for complying with safety standards and for providing adequate designs and safeguards for their hardware, software and systems which minimize risk and avoid situations in which a malfunction or failure of semiconductor devices could cause loss of human life, bodily injury or damage to property, including data loss or corruption. Customers must also refer to and comply with the latest versions of all relevant our information, including without limitation, specifications, data sheets and application notes for semiconductor devices, as well as the precautions and conditions set forth in the "Semiconductor Reliability Handbook".
4. When designing electronics applications by referring to this Reference Design, customers must evaluate the whole system adequately. Customers are solely responsible for all aspects of their own product design or applications. WE ASSUME NO LIABILITY FOR CUSTOMERS' PRODUCT DESIGN OR APPLICATIONS.
5. No responsibility is assumed by us for any infringement of patents or any other intellectual property rights of third parties that may result from the use of this Reference Design. No license to any intellectual property right is granted by this terms of use, whether express or implied, by estoppel or otherwise.
6. THIS REFERENCE DESIGN IS PROVIDED "AS IS". WE (a) ASSUME NO LIABILITY WHATSOEVER, INCLUDING WITHOUT LIMITATION, INDIRECT, CONSEQUENTIAL, SPECIAL, OR INCIDENTAL DAMAGES OR LOSS, INCLUDING WITHOUT LIMITATION, LOSS OF PROFITS, LOSS OF OPPORTUNITIES, BUSINESS INTERRUPTION AND LOSS OF DATA, AND (b) DISCLAIM ANY AND ALL EXPRESS OR IMPLIED WARRANTIES AND CONDITIONS RELATED TO THIS REFERENCE DESIGN, INCLUDING WARRANTIES OR CONDITIONS OF MERCHANTABILITY, FITNESS FOR A PARTICULAR PURPOSE, ACCURACY OF INFORMATION, OR NONINFRINGEMENT.

### 3. Export Control

Customers shall not use or otherwise make available this Reference Design for any military purposes, including without limitation, for the design, development, use, stockpiling or manufacturing of nuclear, chemical, or biological weapons or missile technology products (mass destruction weapons). This Reference Design may be controlled under the applicable export laws and regulations including, without limitation, the Japanese Foreign Exchange and Foreign Trade Law and the U.S. Export Administration Regulations. Export and re-export of this Reference Design are strictly prohibited except in compliance with all applicable export laws and regulations.

### 4. Governing Laws

This terms of use shall be governed and construed by laws of Japan.