

32-Bit RISC Microcontroller

**TXZ+ Family
TMPM3H Group(2)**

**Reference Manual
Product Information
(PINFO-M3H(2))**

Revision 1.0

2023-04

TOSHIBA ELECTRONIC DEVICES & STORAGE CORPORATION

Contents

Preface	9
Related document.....	9
Conventions	10
Terms and Abbreviation.....	12
1. Outlines	13
2. Information of Peripheral Function	13
2.1. Register Base Address	13
2.2. Trigger Selector (TRGSEL)	14
2.2.1. Trigger selector and product table	15
2.2.2. Directions for use and setup	25
2.2.3. List of Registers.....	26
2.2.4. Detail of Registers	27
2.2.4.1. [TSEL0CR0] (Control Register 0).....	27
2.2.4.2. [TSEL0CR1] (Control Register 1).....	29
2.2.4.3. [TSEL0CR2] (Control Register 2).....	31
2.2.4.4. [TSEL0CR3] (Control Register 3).....	33
2.2.4.5. [TSEL0CR4] (Control Register 4).....	35
2.2.4.6. [TSEL0CR5] (Control Register 5).....	37
2.2.4.7. [TSEL0CR6] (Control Register 6).....	39
2.2.4.8. [TSEL0CR7] (Control Register 7).....	41
2.2.4.9. [TSEL0CR8] (Control Register 8).....	43
2.2.4.10. [TSEL0CR9] (Control Register 9).....	45
2.2.4.11. [TSEL0CR10] (Control Register 10).....	47
2.2.4.12. [TSEL0CR11] (Control Register 11).....	49
2.2.4.13. [TSEL0CR12] (Control Register 12).....	51
2.2.4.14. [TSEL0CR13] (Control Register 13).....	53
2.2.4.15. [TSEL0CR14] (Control Register 14).....	55
2.2.4.16. [TSEL0CR15] (Control Register 15).....	57
2.2.4.17. [TSEL1CR0] (Control Register 0).....	59
2.2.4.18. [TSEL1CR1] (Control Register 1).....	61
2.2.4.19. [TSEL1CR2] (Control Register 2).....	63
2.2.4.20. [TSEL1CR3] (Control Register 3).....	65
2.2.4.21. [TSEL1CR4] (Control register 4).....	67
2.3. Clock Selective Watchdog Timer (SIWDT).....	69
2.3.1. Built-in channel	69
2.3.2. Count clock.....	69
2.3.3. Control Output	69
2.4. Oscillation Frequency Detector (OFD)	70
2.4.1. Built-in List.....	70
2.4.2. Reference clock.....	70
2.4.3. Detection object clock.....	70
2.5. Debug interface.....	71
2.5.1. Debugging interface terminal list of each product.....	71

2.5.2. Divided ratio for Trace clock	71
2.6. Flash Memory	72
2.6.1. Clock for Programming/Erasing	72
2.6.2. The code flash block configuration of each product.....	72
2.6.3. The data flash block configuration of each product.	73
2.6.4. Access Control register	74
2.6.5. Macro Code at ID read	74
2.6.6. Single boot use resource.....	74
2.7. DMA Controller (DMAC)	76
2.7.1. Built-in unit.....	76
2.7.2. DMA request list	77
2.8. Advanced Programmable Motor Control Circuit (A-PMD)	85
2.8.1. Built-in channel	85
2.8.2. Functional pin and port	85
2.8.3. DMA request.....	86
2.8.4. Other connections	87
2.9. Advanced Encoder Input Circuit (32-bit) (A-ENC32)	88
2.9.1. Built-in channel	88
2.9.2. Functional pin and port	88
2.9.3. Internal signal connection specification	89
2.9.3.1. T32A/A-PMD connection	89
2.10. 12-bit Analog to Digital Converter (ADC).....	90
2.10.1. Built-in unit.....	90
2.10.2. Functional pin and port	91
2.10.3. Clock for the ADC conversion.....	92
2.10.4. Set of mode setting register 2.....	92
2.10.5. Set of trimming setting register	92
2.10.6. DMA request.....	92
2.10.7. Internal signal connection specification	93
2.10.7.1. Start-trigger connection specification	93
2.10.7.2. T32A/A-PMD connection.....	94
2.11. 8-bit Digital to Analog Converter (DAC).....	95
2.11.1. Built-in channel	95
2.11.2. Functional pin and a port	95
2.12. Comparator (COMP).....	96
2.12.1. Built-in channel.....	96
2.12.2. Functional pin and Destination	96
2.13. Voltage Detection Circuit (LVD).....	97
2.13.1. Built-in List.....	97
2.13.2. LVD Detection power supply	97
2.14. 32-bit Timer Event Counter (T32A).....	98
2.14.1. Built-in channel	98
2.14.2. Functional pin and port	98
2.14.3. Clock for prescaler.....	100

2.14.4. Internal signal connection specification	100
2.14.4.1. Capture trigger signal connection specification	101
2.14.4.2. Synchronous control connection specification	109
2.14.5. Pulse count correspondence classified by product List	111
2.14.6. DMA request.....	112
2.14.7. Non corresponding interrupt	115
2.15. Real Time Clock (RTC).....	115
2.15.1. Built-in channel	115
2.15.2. Functional pin and port	115
2.15.3. RTC count clock	115
2.16. Asynchronous Serial Communication Circuit (UART)	116
2.16.1. Built-in channel	116
2.16.2. Functional pin and port	116
2.16.3. Half clock mode list for each product.....	118
2.16.4. Clock for prescaler.....	118
2.16.5. DMA request.....	119
2.16.6. Internal signal connection specification	120
2.16.6.1. Trigger transmission signal connection specification	120
2.16.6.2. T32A connection	122
2.17. I ² C interface (I2C)	123
2.17.1. Built-in channel	123
2.17.2. Functional pin and port	123
2.17.3. Clock for prescaler.....	123
2.17.4. Address match wakeup function support.....	125
2.17.5. Noise filter	125
2.17.6. DMA request.....	126
2.18. I ² C interface version A (EI2C).....	127
2.18.1. Built-in channel	127
2.18.2. Functional pin and port	127
2.18.3. Clock for prescaler.....	127
2.18.4. Address match wakeup function support (I2CS).....	128
2.18.5. Noise filter	128
2.18.6. DMA request.....	129
2.19. Serial Peripheral Interface (TSPI).....	130
2.19.1. Built-in channel	130
2.19.2. Functional pin and port	131
2.19.3. Transfer mode list for each product	132
2.19.4. Setting Value of $[TSPIxCR2]<RXDLY[2:0]>$	132
2.19.5. Clock for TSPI	132
2.19.6. DMA request.....	133
2.19.7. Internal signal connection specification	134
2.19.7.1. Trigger transmitting signal connection specification	134
2.19.7.2. T32A connection	135
2.20. LCD display control circuit (DLCD)	136

2.20.1. Built-in List.....	136
2.20.2. Functional pin and port.....	136
2.20.3. Pin setting registers.....	138
2.20.3.1. Output selection.....	138
2.20.3.2. Pin Function switching.....	139
2.20.4. Pin assignment switching function.....	139
2.21. Remote Control Signal Preprocessor (RMC).....	140
2.21.1. Built-in channel.....	140
2.21.2. Functional pin and port.....	140
2.21.3. Sampling clock.....	140
2.22. Digital Noise Filter Circuit (DNF).....	141
2.22.1. Built-in unit.....	141
2.22.2. External interrupt pin and DNF.....	142
2.22.3. Sampling source clock.....	143
2.23. CRC calculation Circuit (CRC).....	143
2.23.1. Built-in channel.....	143
2.24. RAM Parity (RAMP).....	143
2.24.1. Built-in channel.....	143
2.24.2. Error judgment Block Area.....	144
2.25. Trimming Circuit (TRM).....	144
2.25.1. Built-in List.....	144
2.25.2. Object oscillator.....	144
3. Revision History.....	145
RESTRICTIONS ON PRODUCT USE.....	146

List of Figures

Figure 2.1	Example of trigger Selector Connection	14
Figure 2.2	Trigger and TRGSEL connection overview (T32A ch0)	101
Figure 2.3	Trigger and TRGSEL connection overview (T32A ch1)	102
Figure 2.4	Trigger and TRGSEL connection overview (T32A ch2)	103
Figure 2.5	Trigger and TRGSEL connection overview (T32A ch3)	104
Figure 2.6	Trigger and TRGSEL connection overview (T32A ch4)	105
Figure 2.7	Trigger and TRGSEL connection overview (T32A ch5)	106
Figure 2.8	Trigger and TRGSEL connection overview (T32A ch6)	107
Figure 2.9	Trigger and TRGSEL connection overview (T32A ch7)	108

List of Tables

Table 2.1	Register Base Address Type	13
Table 2.2	Trigger selector and product table (1/15)	15
Table 2.3	Trigger selector and product table (2/15)	16
Table 2.4	Trigger selector and product table (3/15)	17
Table 2.5	Trigger selector and product table (4/15)	18
Table 2.6	Trigger selector and product table (5/15)	19
Table 2.7	Trigger selector and product table (6/15)	19
Table 2.8	Trigger selector and product table (7/15)	20
Table 2.9	Trigger selector and product table (8/15)	20
Table 2.10	Trigger selector and product table (9/15)	21
Table 2.11	Trigger selector and product table (10/15)	21
Table 2.12	Trigger selector and product table (11/15)	22
Table 2.13	Trigger selector and product table (12/15)	22
Table 2.14	Trigger selector and product table (13/15)	23
Table 2.15	Trigger selector and product table (14/15)	23
Table 2.16	Trigger selector and product table (15/15)	24
Table 2.17	SIWDT Built-in channel.....	69
Table 2.18	SIWDT Count clock.....	69
Table 2.19	SIWDT Control Output.....	69
Table 2.20	OFD Built-in List.....	70
Table 2.21	OFD Reference clock.....	70
Table 2.22	OFD Detection object clock	70
Table 2.23	Debugging interface terminal list	71
Table 2.24	Divided ratio for Trace Clock (TRACECLK).....	71
Table 2.25	Clock for Programming/Erasing.....	72
Table 2.26	The code flash of each product	72
Table 2.27	The data flash of each product	73
Table 2.28	Access Control register.....	74
Table 2.29	Macro Code at ID read.....	74
Table 2.30	Single boot use resource	74
Table 2.31	The end address in which RAM transmission is possible	74
Table 2.32	DMAC Built-in unit.....	76
Table 2.33	DMA unit A Request list (1/4)	77
Table 2.34	DMA unit A Request list (2/4)	78
Table 2.35	DMA unit A Request list (3/4)	79
Table 2.36	DMA unit A Request list (4/4)	80
Table 2.37	DMA unit B Request list (1/4)	81
Table 2.38	DMA unit B Request list (2/4)	82
Table 2.39	DMA unit B Request list (3/4)	83
Table 2.40	DMA unit B Request list (4/4)	84
Table 2.41	A-PMD Built-in channel.....	85
Table 2.42	A-PMD Functional pin	85
Table 2.43	A-PMD DMA request	86
Table 2.44	A-PMD ch0 Internal signal connection specification: Input	87

Table 2.45	A-PMD ch0 Internal signal connection specification: Output	87
Table 2.46	A-ENC32 Built-in channel	88
Table 2.47	A-ENC32 Functional pin and port	88
Table 2.48	A-ENC32 Internal signal connection specification: Input.....	89
Table 2.49	A-ENC32 Internal signal connection specification: Output.....	89
Table 2.50	ADC Built-in unit.....	90
Table 2.51	ADC Functional pin and a port.....	91
Table 2.52	ADC Clock for the conversion.....	92
Table 2.53	Set of mode setting register 2.....	92
Table 2.54	Set of trimming setting register	92
Table 2.55	ADC DMA request	92
Table 2.56	ADC Start trigger connection specification	93
Table 2.57	ADC Internal signal connection specification: Output	94
Table 2.58	DAC Built-in channel.....	95
Table 2.59	DAC Functional pin and a port.....	95
Table 2.60	Comparator Built-in channel	96
Table 2.61	Comparator functional pin and destination	96
Table 2.62	LVD Built-in List.....	97
Table 2.63	LVD Detection power supply	97
Table 2.64	T32A Built-in channel.....	98
Table 2.65	T32A Functional pin and a port (1/3)	98
Table 2.66	T32A Functional signal and a port (2/3)	99
Table 2.67	T32A Functional pin and a port (3/3)	100
Table 2.68	T32A Clock for prescaler	100
Table 2.69	T32A Capture trigger signal connection specification (1/8).....	101
Table 2.70	T32A Capture trigger signal connection specification (2/8).....	102
Table 2.71	T32A Capture trigger signal connection specification (3/8).....	103
Table 2.72	T32A Capture trigger signal connection specification (4/8).....	104
Table 2.73	T32A Capture trigger signal connection specification (5/8).....	105
Table 2.74	T32A Capture trigger signal connection specification (6/8).....	106
Table 2.75	T32A Capture trigger signal connection specification (7/8).....	107
Table 2.76	T32A Capture trigger signal connection specification (8/8).....	108
Table 2.77	T32A Synchronous control connection specification (1/2)	109
Table 2.78	T32A Synchronous control connection specification (2/2)	110
Table 2.79	T32A Pulse count support list	111
Table 2.80	T32A DMA request (1/3)	112
Table 2.81	T32A DMA request (2/3)	113
Table 2.82	T32A DMA request (3/3)	114
Table 2.83	RTC Built-in List	115
Table 2.84	RTC Functional pin and a port.....	115
Table 2.85	RTC Count clock.....	115
Table 2.86	UART Built-in channel.....	116
Table 2.87	UART Functional pin signal and a port (1/2)	117
Table 2.88	UART Functional pin signal and a port (2/2)	118
Table 2.89	UART Half clock mode adaptive list	118
Table 2.90	UART Clock for prescaler	118
Table 2.91	UART DMA request	119
Table 2.92	UART Trigger transmission signal connection specification (1/2).....	120
Table 2.93	UART Trigger transmission signal connection specification (2/2).....	121
Table 2.94	UART Internal connection specification: Output.....	122
Table 2.95	I ² C interface Built-in channel.....	123
Table 2.96	I ² C interface Functional pin and port	123
Table 2.97	I ² C interface Clock for prescaler	123
Table 2.98	I ² C interface Address match wakeup function (I2CS) adaptive list.....	125
Table 2.99	I ² C interface Noise Filter	125
Table 2.100	I ² C interface DMA request	126
Table 2.101	I ² C interface version A Built-in channel	127
Table 2.102	I ² C interface version A Functional pin and port	127
Table 2.103	I ² C interface version A Clock for prescaler.....	127
Table 2.104	I ² C interface version A Address match wakeup function (I2CS) adaptive list.....	128

Table 2.105	I ² C interface version A Noise Filter	128
Table 2.106	I ² C interface version A DMA request	129
Table 2.107	TSPI Built-in channel	130
Table 2.108	TSPI Functional pin and a port	131
Table 2.109	TSPI Mode support list.....	132
Table 2.110	Setting Value of TSPI control register2<RXDLY>	132
Table 2.111	Clock for TSPI	132
Table 2.112	TSPI DMA request	133
Table 2.113	TSPI Trigger transmission specification	134
Table 2.114	TSPI Internal connection specification (Output)	135
Table 2.115	DLCD Built-in List.....	136
Table 2.116	DLCD Functional pin and a port	136
Table 2.117	RMC Built-in channel	140
Table 2.118	RMC Functional pin and a port.....	140
Table 2.119	RMC Sampling clock.....	140
Table 2.120	DNF Built-in unit.....	141
Table 2.121	External interrupt pin and DNF correspondence	142
Table 2.122	DNF Sampling source clock	143
Table 2.123	CRC Built-in channel.....	143
Table 2.124	RAM Parity Built-in channel.....	143
Table 2.125	RAM area and address of RAM Parity	144
Table 2.126	TRM Built-in List.....	144
Table 2.127	TRM Trimming oscillator	144
Table 3.1	Revision History	145

Preface

Related document

Document name	IP Symbol
Input/Output Ports (TMPM3H Group(2))	PORT-M3H(2)
Clock Control and Operation Mode (TMPM3H Group(2))	CG-M3H(2)-D
Exception (TMPM3H Group(2))	EXCEPT-M3H(2)
Flash Memory	FLASH10MUD32-A
Debug Interface	DEBUG-A
DMA Controller	DMAC-B
32-bit Timer Event Counter	T32A-C
Asynchronous Serial Communication Circuit	UART-C
Serial Peripheral Interface	TSPI-E
I ² C interface	I2C-B
I ² C interface version A	EI2C-A
12-bit Analog to Digital Converter	ADC-G
8-bit Digital to Analog Converter	DAC-B
Advanced Programmable Motor Control Circuit	A-PMD-B
Advanced Encoder Input Circuit (32-bit)	A-ENC32-A
Clock Selective Watchdog Timer	SIWDT-A
LCD Display control Circuit	DLCD-A
Remote Control Signal Preprocessor	RMC-A
Real Time Clock	RTC-A
Oscillation Frequency Detector	OFD-A
Digital Noise Filter Circuit	DNF-A
Trimming Circuit	TRM-B
Voltage Detection Circuit	LVD-D
CRC calculation circuit	CRC-A
RAM parity	RAMP-A
Comparator	COMP-C

Conventions

- Numeric formats follow the rules as shown below:
 - Hexadecimal: 0xABC
 - Decimal: 123 or 0d123 – Only when it needs to be explicitly shown that they are decimal numbers.
 - Binary: 0b111 – It is possible to omit the "0b" when the number of bits can be distinctly understood from a sentence.
- "_N" is added to the end of signal names to indicate low active signals.
- It is called "assert" that a signal moves to its active level, "deassert" to its inactive level.
- When two or more signal names are referred, they are described like as [m: n].
 Example: S[3: 0] shows four signal names S3, S2, S1 and S0 together.
- The characters surrounded by [] defines the register.
 Example: [ABCD]
- "n" substitutes suffix number of two or more same kind of registers, fields, and bit names.
 Example: [XYZ1], [XYZ2], [XYZ3] → [XYZn]
- "x" substitutes suffix number or character of units and channels in the Register List.
 - In case of unit, "x" means A, B, and C . . .
 - Example: [ADACR0], [ADBCR0], [ADCCR0] → [ADxCR0]
 - In case of channel, "x" means 0, 1, and 2 . . .
 - Example: [T32A0RUNA], [T32A1RUNA], [T32A2RUNA] → [T32AxRUNA]
- The bit range of a register is written like as [m: n].
 Example: Bit[3: 0] expresses the range of bit 3 to 0.
- The configuration value of a register is expressed by either the hexadecimal number or the binary number.
 Example: [ABCD]<EFG> = 0x01 (hexadecimal), [XYZn]<VW> = 1 (binary)
- Word and Byte represent the following bit length.
 - Byte: 8 bits
 - Half word: 16 bits
 - Word: 32 bits
 - Double word: 64 bits
- Properties of each bit in a register are expressed as follows:
 - R: Read only
 - W: Write only
 - R/W: Read and Write are possible
- Unless otherwise specified, register access supports only word access.
- The register defined as reserved must not be rewritten. Moreover, do not use the read value.
- The value read from the bit having default value of "-" is unknown.
- When a register containing both of writable bits and read-only bits is written, read-only bits should be written with their default value, In the cases that default is "-", follow the definition of each register.
- Reserved bits of the Write-only register should be written with their default value. In the cases that default is "-", follow the definition of each register.
- Do not use read-modified-write processing to the register of a definition which is different by writing and read out.

All other company names, product names, and service names mentioned herein may be trademarks of their respective companies.

Terms and Abbreviation

Some of abbreviations used in this document are as follows:

ADC	Analog to Digital Converter
A-ENC32	Advanced Encoder input Circuit (32-bit)
A-PMD	Advanced Programmable Motor Control Circuit
COMP	Comparator
CRC	Cyclic Redundancy Check
DAC	Digital to Analog Converter
DMAC	Direct Memory Access Controller
DNF	Digital Noise Filter
EHOSC	External High Speed Oscillator
EI2C	I ² C Interface Version A
ELOSC	External Low Speed Oscillator
IHOSC	Internal High Speed Oscillator
INT	Interrupt
I ² C	Inter-Integrated Circuit
I2CS	Wake-up function by address matching
LCD	Liquid Crystal Display
LVD	Voltage Detection Circuit
OFD	Oscillation Frequency Detector
RAMP	RAM Parity
RMC	Remote control signal preprocessor
RTC	Real Time Clock
SIWDT	Clock Selective Watchdog timer
TRGSEL	Trigger Selection circuit
TRM	Trimming circuit
TSPI	Serial Peripheral Interface
T32A	32-bit Timer Event counter
UART	Universal Asynchronous Receiver Transmitter

1. Outlines

This chapter describes number of channels or units, information of pins, and product specific function information related to peripheral functions.

2. Information of Peripheral Function

2.1. Register Base Address

The type of the register base address used by each peripheral function is shown in the following table.

Table 2.1 Register Base Address Type

Product	Register Base Address Type
TMPM3H Group(2)	TYPE1

Please develop each peripheral function with reference to the above mentioned base address type.

If there is no description of "TYPE1/TYPE2/TYPE3" in the register base address of the reference manual, please use it as TYPE1.

2.2. Trigger Selector (TRGSEL)

The trigger selector is the circuit which selects the one trigger and outputs the trigger signal to the peripheral function from two or more triggers inputted from the peripheral function, the port, etc.

The trigger selected from eight triggers by $[TSELxCRn]<INSELm>$ is outputted to the peripheral function of a connection destination.

"Figure 2.1 Example of trigger Selector Connection" is the example of the trigger signals which are port terminals (PB1, PA3, PN3) and timer register (A1, B1, C1) match triggers from the 32-bit timer event counter (channel 6) are connected to TSPI (channel 0) via the trigger selector. The setup of input trigger selection ($<INSEL39[2:0]>$), edge detection condition selection ($<UPDN39>$), trigger output selection ($<OUTSEL39>$), and trigger output enable/disable selection ($<EN39>$) is performed.

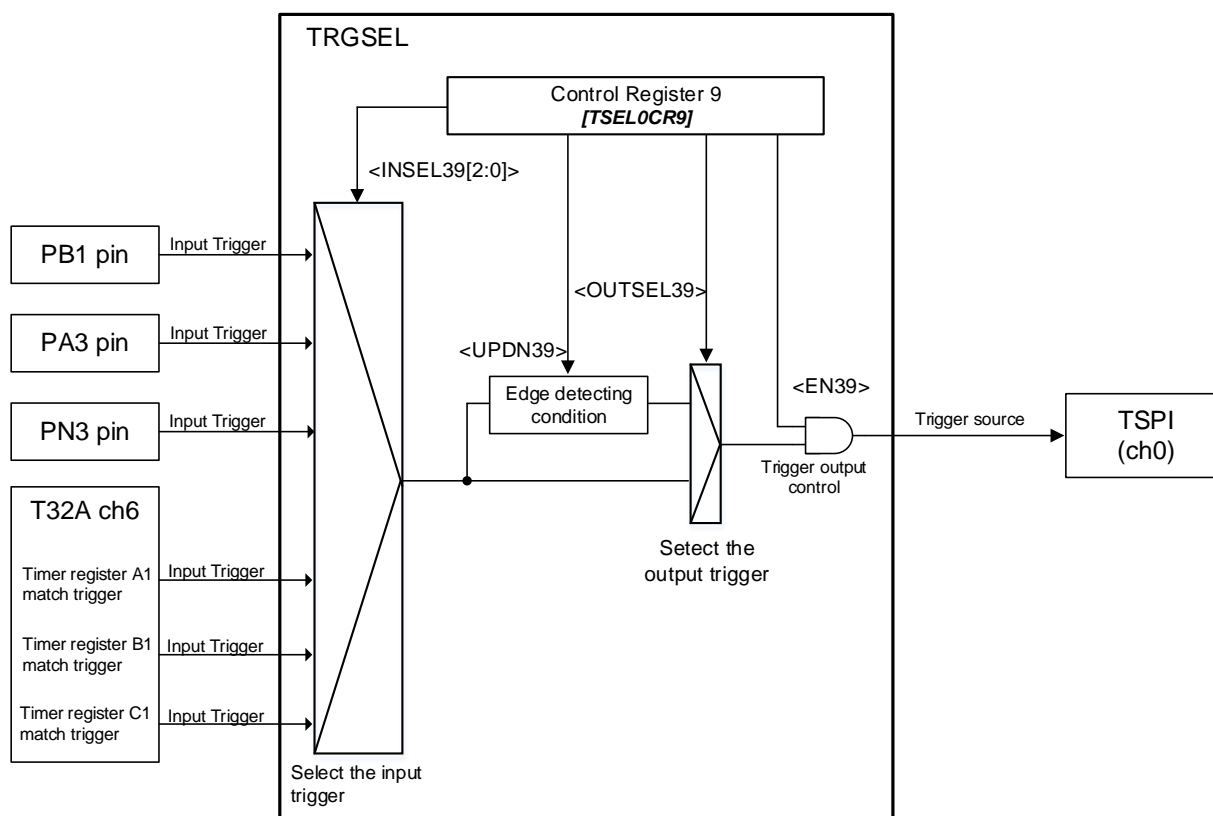

Figure 2.1 Example of trigger Selector Connection

2.2.1. Trigger selector and product table

The trigger selector of TMPM3H Group(2) consists of 21 control registers (*[TSEL0CR0]* to *[TSEL0CR15]*, *[TSEL1CR0]* to *[TSEL1CR4]*), and can control 84 triggers.

The control register, the connection destination, and correspondence products are shown in the following table.

Table 2.2 Trigger selector and product table (1/15)

Register	Bit Symbol	Trigger Source	Input Trigger	Product table (✓: Available, -: N/A)				
				M3HQ	M3HP	M3HN	M3HM	M3HL
<i>[TSEL0CR0]</i>	INSEL0[2:0]	DMAC A ch15	- T32A ch0 DMA request at match A1 register - T32A ch0 DMA request at match C1 register - T32A ch1 DMA request at match A1 register - T32A ch1 DMA request at match C1 register	✓	✓	✓	✓	✓
	INSEL1[2:0]	DMAC A ch16	- T32A ch2 DMA request at match A1 register - T32A ch2 DMA request at match C1 register - T32A ch3 DMA request at match A1 register - T32A ch3 DMA request at match C1 register	✓	✓	✓	✓	✓
	INSEL2[2:0]	DMAC A ch17	- T32A ch0 DMA request at match B1 register - T32A ch1 DMA request at match B1 register	✓	✓	✓	✓	✓
	INSEL3[2:0]	DMAC A ch18	- T32A ch2 DMA request at match B1 register - T32A ch3 DMA request at match B1 register	✓	✓	✓	✓	✓
<i>[TSEL0CR1]</i>	INSEL4[2:0]	DMAC A ch19	- T32A ch0 DMA request at capture A0 register - T32A ch0 DMA request at capture A1 register - T32A ch1 DMA request at capture A0 register - T32A ch1 DMA request at capture A1 register - T32A ch0 DMA request at capture C0 register - T32A ch0 DMA request at capture C1 register - T32A ch1 DMA request at capture C0 register - T32A ch1 DMA request at capture C1 register	✓	✓	✓	✓	✓
	INSEL5[2:0]	DMAC A ch20	- T32A ch2 DMA request at capture A0 register - T32A ch2 DMA request at capture A1 register - T32A ch3 DMA request at capture A0 register - T32A ch3 DMA request at capture A1 register - T32A ch2 DMA request at capture C0 register - T32A ch2 DMA request at capture C1 register - T32A ch3 DMA request at capture C0 register - T32A ch3 DMA request at capture C1 register	✓	✓	✓	✓	✓
	INSEL6[2:0]	DMAC A ch21	- T32A ch0 DMA request at capture B0 register - T32A ch0 DMA request at capture B1 register - T32A ch1 DMA request at capture B0 register - T32A ch1 DMA request at capture B1 register	✓	✓	✓	✓	✓
	INSEL7[2:0]	DMAC A ch22	- T32A ch2 DMA request at capture B0 register - T32A ch2 DMA request at capture B1 register - T32A ch3 DMA request at capture B0 register - T32A ch3 DMA request at capture B1 register	✓	✓	✓	✓	✓

Table 2.3 Trigger selector and product table (2/15)

Register	Bit Symbol	Trigger Source	Input Trigger	Product table (✓: Available, -: N/A)				
				M3HQ	M3HP	M3HN	M3HM	M3HL
[TSEL0CR2]	INSEL8[2:0]	DMAC A ch23	- DMAC A ch0 transmission end interrupt - DMAC A ch1 transmission end interrupt - DMAC A ch6 transmission end interrupt - DMAC A ch7 transmission end interrupt	✓	✓	✓	✓	✓
	INSEL9[2:0]	DMAC A ch24	- DMAC A ch2 transmission end interrupt - DMAC A ch3 transmission end interrupt - DMAC A ch8 transmission end interrupt - DMAC A ch9 transmission end interrupt	✓	✓	✓	✓	✓
	INSEL10[2:0]	DMAC A ch25	- DMAC A ch4 transmission end interrupt - DMAC A ch5 transmission end interrupt - DMAC A ch10 transmission end interrupt - DMAC A ch11 transmission end interrupt	✓	✓	✓	✓	✓
	INSEL11[2:0]	DMAC A ch26	- DMAC A ch12 transmission end interrupt - DMAC A ch13 transmission end interrupt - DMAC A ch14 transmission end interrupt	✓	✓	✓	✓	✓
[TSEL0CR3]	INSEL12[2:0]	DMAC A ch27	- DMAC A ch15 transmission end interrupt - DMAC A ch19 transmission end interrupt	✓	✓	✓	✓	✓
	INSEL13[2:0]	DMAC A ch28	- DMAC A ch16 transmission end interrupt - DMAC A ch20 transmission end interrupt	✓	✓	✓	✓	✓
	INSEL14[2:0]	DMAC A ch29	- DMAC A ch17 transmission end interrupt - DMAC A ch21 transmission end interrupt	✓	✓	✓	✓	✓
	INSEL15[2:0]	DMAC A ch30	- DMAC A ch18 transmission end interrupt - DMAC A ch22 transmission end interrupt	✓	✓	✓	✓	✓
[TSEL0CR4]	INSEL16[2:0]	DMAC A ch31	- PB1 pin (TRGIN0) - PA3 pin (TRGIN1) - PN3 pin (TRGIN2)	✓	✓	✓	✓	✓
	INSEL17[2:0]	DMAC B ch0	- TSPI ch2 Receive DMA request	✓	✓	✓	✓	-
			- I2C ch3 Receiving DMA request - EI2C ch3 Receiving DMA request	✓	✓	-	-	-
	INSEL18[2:0]	DMAC B ch1	- TSPI ch2 Transmit DMA request	✓	✓	✓	✓	-
- I2C ch3 Transmitting DMA request - EI2C ch3 Transmitting DMA request			✓	✓	-	-	-	
INSEL19[2:0]	DMAC B ch14	- ADC Unit A General purpose trigger DMA request - ADC Unit A Single conversion DMA request - ADC Unit A Continuous conversion DMA request	✓	✓	✓	✓	✓	
[TSEL0CR5]	INSEL20[2:0]	DMAC B ch15	- T32A ch4 DMA request at match A1 register - T32A ch4 DMA request at match C1 register - T32A ch5 DMA request at match A1 register - T32A ch5 DMA request at match C1 register	✓	✓	✓	✓	✓
	INSEL21[2:0]	DMAC B ch16	- T32A ch6 DMA request at match A1 register - T32A ch6 DMA request at match C1 register - T32A ch7 DMA request at match A1 register - T32A ch7 DMA request at match C1 register	✓	✓	✓	✓	✓
	INSEL22[2:0]	DMAC B ch17	- T32A ch4 DMA request at match B1 register - T32A ch5 DMA request at match B1 register - UART ch6 Reception DMA request	✓	✓	✓	✓	✓
	INSEL23[2:0]	DMAC B ch18	- T32A ch6 DMA request at match B1 register - T32A ch7 DMA request at match B1 register - UART ch6 Transmission DMA request	✓	✓	✓	✓	✓

Table 2.4 Trigger selector and product table (3/15)

Register	Bit Symbol	Trigger Source	Input Trigger	Product table (✓: Available, -: N/A)				
				M3HQ	M3HP	M3HN	M3HM	M3HL
[TSEL0CR6]	INSEL24[2:0]	DMAC B ch19	- T32A ch4 DMA request at capture A0 register - T32A ch4 DMA request at capture A1 register - T32A ch5 DMA request at capture A0 register - T32A ch5 DMA request at capture A1 register - T32A ch4 DMA request at capture C0 register - T32A ch4 DMA request at capture C1 register - T32A ch5 DMA request at capture C0 register - T32A ch5 DMA request at capture C1 register	✓	✓	✓	✓	✓
	INSEL25[2:0]	DMAC B ch20	- T32A ch6 DMA request at capture A0 register - T32A ch6 DMA request at capture A1 register - T32A ch7 DMA request at capture A0 register - T32A ch7 DMA request at capture A1 register - T32A ch6 DMA request at capture C0 register - T32A ch6 DMA request at capture C1 register - T32A ch7 DMA request at capture C0 register - T32A ch7 DMA request at capture C1 register	✓	✓	✓	✓	✓
	INSEL26[2:0]	DMAC B ch21	- T32A ch4 DMA request at capture B0 register - T32A ch4 DMA request at capture B1 register - T32A ch5 DMA request at capture B0 register - T32A ch5 DMA request at capture B1 register	✓	✓	✓	✓	✓
			- UART ch7 Reception DMA request	✓	✓	✓	-	-
INSEL27[2:0]	DMAC B ch22	- T32A ch6 DMA request at capture B0 register - T32A ch6 DMA request at capture B1 register - T32A ch7 DMA request at capture B0 register - T32A ch7 DMA request at capture B1 register	✓	✓	✓	✓	✓	
		- UART ch7 Transmission DMA request	✓	✓	✓	-	-	
[TSEL0CR7]	INSEL28[2:0]	DMAC B ch23	- DMAC B ch0 transmission end interrupt - DMAC B ch1 transmission end interrupt - DMAC B ch6 transmission end interrupt - DMAC B ch7 transmission end interrupt	✓	✓	✓	✓	✓
	INSEL29[2:0]	DMAC B ch24	- DMAC B ch2 transmission end interrupt - DMAC B ch3 transmission end interrupt - DMAC B ch8 transmission end interrupt - DMAC B ch9 transmission end interrupt	✓	✓	✓	✓	✓
	INSEL30[2:0]	DMAC B ch25	- DMAC B ch4 transmission end interrupt - DMAC B ch5 transmission end interrupt - DMAC B ch10 transmission end interrupt - DMAC B ch11 transmission end interrupt	✓	✓	✓	✓	✓
	INSEL31[2:0]	DMAC B ch26	- DMAC B ch12 transmission end interrupt - DMAC B ch13 transmission end interrupt - DMAC B ch14 transmission end interrupt	✓	✓	✓	✓	✓

Table 2.5 Trigger selector and product table (4/15)

Register	Bit Symbol	Trigger Source	Input Trigger	Product table (✓: Available, -: N/A)				
				M3HQ	M3HP	M3HN	M3HM	M3HL
[TSEL0CR8]	INSEL32[2:0]	DMAC B ch27	- DMAC B ch15 transmission end interrupt - DMAC B ch19 transmission end interrupt	✓	✓	✓	✓	✓
	INSEL33[2:0]	DMAC B ch28	- DMAC B ch16 transmission end interrupt - DMAC B ch20 transmission end interrupt	✓	✓	✓	✓	✓
	INSEL34[2:0]	DMAC B ch29	- DMAC B ch17 transmission end interrupt - DMAC B ch21 transmission end interrupt	✓	✓	✓	✓	✓
	INSEL35[2:0]	DMAC B ch30	- DMAC B ch18 transmission end interrupt - DMAC B ch22 transmission end interrupt	✓	✓	✓	✓	✓
[TSEL0CR9]	INSEL36[2:0]	DMAC B ch31	- PB1 pin (TRGIN0) - PA3 pin (TRGIN1) - PN3 pin (TRGIN2)	✓	✓	✓	✓	✓
	INSEL37[2:0]	ADC (PMDTRG6)	- PB1 pin (TRGIN0) - PA3 pin (TRGIN1) - PN3 pin (TRGIN2) - T32A ch7 Timer register A1 match trigger - T32A ch7 Timer register B1 match trigger - T32A ch7 Timer register C1 match trigger	✓	✓	✓	✓	✓
	INSEL38[2:0]	ADC (ADATRGIN) (General purpose trigger)	- PB1 pin (TRGIN0) - PA3 pin (TRGIN1) - PN3 pin (TRGIN2) - T32A ch7 Timer register A1 match trigger - T32A ch7 Timer register B1 match trigger - T32A ch7 Timer register C1 match trigger	✓	✓	✓	✓	✓
	INSEL39[2:0]	TSPI ch0	- PB1 pin (TRGIN0) - PA3 pin (TRGIN1) - PN3 pin (TRGIN2) - T32A ch6 Timer register A1 match trigger - T32A ch6 Timer register B1 match trigger - T32A ch6 Timer register C1 match trigger	✓	✓	✓	✓	✓

Table 2.6 Trigger selector and product table (5/15)

Register	Bit Symbol	Trigger Source	Input Trigger	Product table (✓: Available, -: N/A)				
				M3HQ	M3HP	M3HN	M3HM	M3HL
[TSEL0CR10]	INSEL40[2:0]	TSPI ch1	- PB1 pin (TRGIN0) - PA3 pin (TRGIN1) - PN3 pin (TRGIN2) - T32A ch6 Timer register A1 match trigger - T32A ch6 Timer register B1 match trigger - T32A ch6 Timer register C1 match trigger	✓	✓	✓	✓	-
	INSEL41[2:0]	TSPI ch2	- PB1 pin (TRGIN0) - PA3 pin (TRGIN1) - PN3 pin (TRGIN2) - T32A ch6 Timer register A1 match trigger - T32A ch6 Timer register B1 match trigger - T32A ch6 Timer register C1 match trigger	✓	✓	✓	✓	-
	INSEL42[2:0]	TSPI ch3	- PB1 pin (TRGIN0) - PA3 pin (TRGIN1) - PN3 pin (TRGIN2) - T32A ch6 Timer register A1 match trigger - T32A ch6 Timer register B1 match trigger - T32A ch6 Timer register C1 match trigger	✓	✓	✓	✓	-
	INSEL43[2:0]	TSPI ch4	- PB1 pin (TRGIN0) - PA3 pin (TRGIN1) - PN3 pin (TRGIN2) - T32A ch6 Timer register A1 match trigger - T32A ch6 Timer register B1 match trigger - T32A ch6 Timer register C1 match trigger	✓	✓	-	-	-

Table 2.7 Trigger selector and product table (6/15)

Register	Bit Symbol	Trigger Source	Input Trigger	Product table (✓: Available, -: N/A)				
				M3HQ	M3HP	M3HN	M3HM	M3HL
[TSEL0CR11]	INSEL44[2:0]	UART ch0	- PB1 pin (TRGIN0) - PA3 pin (TRGIN1) - PN3 pin (TRGIN2) - T32A ch6 Timer register A1 match trigger - T32A ch6 Timer register B1 match trigger - T32A ch6 Timer register C1 match trigger	✓	✓	✓	✓	✓
	INSEL45[2:0]	UART ch1	- PB1 pin (TRGIN0) - PA3 pin (TRGIN1) - PN3 pin (TRGIN2) - T32A ch6 Timer register A1 match trigger - T32A ch6 Timer register B1 match trigger - T32A ch6 Timer register C1 match trigger	✓	✓	✓	✓	✓
	INSEL46[2:0]	UART ch2	- PB1 pin (TRGIN0) - PA3 pin (TRGIN1) - PN3 pin (TRGIN2) - T32A ch6 Timer register A1 match trigger - T32A ch6 Timer register B1 match trigger - T32A ch6 Timer register C1 match trigger	✓	✓	✓	✓	✓
	INSEL47[2:0]	UART ch3	- PB1 pin (TRGIN0) - PA3 pin (TRGIN1) - PN3 pin (TRGIN2) - T32A ch6 Timer register A1 match trigger - T32A ch6 Timer register B1 match trigger - T32A ch6 Timer register C1 match trigger	✓	✓	✓	✓	✓

Table 2.8 Trigger selector and product table (7/15)

Register	Bit Symbol	Trigger Source	Input Trigger	Product table (✓: Available, -: N/A)				
				M3HQ	M3HP	M3HN	M3HM	M3HL
[TSEL0CR12]	INSEL48[2:0]	UART ch4	- PB1 pin (TRGIN0) - PA3 pin (TRGIN1) - PN3 pin (TRGIN2) - T32A ch6 Timer register A1 match trigger - T32A ch6 Timer register B1 match trigger - T32A ch6 Timer register C1 match trigger	✓	✓	✓	✓	✓
	INSEL49[2:0]	UART ch5	- PB1 pin (TRGIN0) - PA3 pin (TRGIN1) - PN3 pin (TRGIN2) - T32A ch6 Timer register A1 match trigger - T32A ch6 Timer register B1 match trigger - T32A ch6 Timer register C1 match trigger	✓	✓	✓	✓	✓
	INSEL50[2:0]	[TSEL1CR3] <INSEL76[2:0]>	- PB1 pin (TRGIN0) - PA3 pin (TRGIN1) - PN3 pin (TRGIN2) - UART ch0 Transmission completion trigger - UART ch0 Reception completion trigger	✓	✓	✓	✓	✓
	INSEL51[2:0]	T32A ch0 Timer B	- T32A ch0 Timer register A0 match trigger - T32A ch0 Timer register A1 match trigger - T32A ch0 Timer A overflow trigger - T32A ch0 Timer A underflow trigger	✓	✓	✓	✓	✓

Table 2.9 Trigger selector and product table (8/15)

Register	Bit Symbol	Trigger Source	Input Trigger	Product table (✓: Available, -: N/A)				
				M3HQ	M3HP	M3HN	M3HM	M3HL
[TSEL0CR13]	INSEL52[2:0]	T32A ch0 Timer C	- T32A ch7 Timer register C0 match trigger - T32A ch7 Timer register C1 match trigger - T32A ch7 Timer C overflow trigger - T32A ch7 Timer C underflow trigger	✓	✓	✓	✓	✓
	INSEL53[2:0]	[TSEL1CR3] <INSEL77[2:0]>	- PB1 pin (TRGIN0) - PA3 pin (TRGIN1) - PN3 pin (TRGIN2) - UART ch1 Transmission completion trigger - UART ch1 Reception completion trigger - I2C ch0 interrupt - EI2C ch0 status interrupt	✓	✓	✓	✓	✓
	INSEL54[2:0]	T32A ch1 Timer B	- T32A ch1 Timer register A0 match trigger - T32A ch1 Timer register A1 match trigger - T32A ch1 Timer A overflow trigger - T32A ch1 Timer A underflow trigger	✓	✓	✓	✓	✓
	INSEL55[2:0]	T32A ch1 Timer C	- T32A ch0 Timer register C0 match trigger - T32A ch0 Timer register C1 match trigger - T32A ch0 Timer C overflow trigger - T32A ch0 Timer C underflow trigger	✓	✓	✓	✓	✓

Table 2.10 Trigger selector and product table (9/15)

Register	Bit Symbol	Trigger Source	Input Trigger	Product table (✓: Available, -: N/A)				
				M3HQ	M3HP	M3HN	M3HM	M3HL
[TSEL0CR14]	INSEL56[2:0]	[TSEL1CR3] <INSEL78[2:0]>	- PB1 pin (TRGIN0) - PA3 pin (TRGIN1) - PN3 pin (TRGIN2) - UART ch2 Transmission completion trigger - UART ch2 Reception completion trigger - TSPI ch0 Transmit complete trigger - TSPI ch0 Receive complete trigger	✓	✓	✓	✓	✓
			- I2C ch1 interrupt - EI2C ch1 status interrupt	✓	✓	✓	✓	-
	INSEL57[2:0]	T32A ch2 Timer B	- T32A ch2 Timer register A0 match trigger - T32A ch2 Timer register A1 match trigger - T32A ch2 Timer A overflow trigger - T32A ch2 Timer A underflow trigger	✓	✓	✓	✓	✓
	INSEL58[2:0]	T32A ch2 Timer C	- T32A ch1 Timer register C0 match trigger - T32A ch1 Timer register C1 match trigger - T32A ch1 Timer C overflow trigger - T32A ch1 Timer C underflow trigger	✓	✓	✓	✓	✓
	INSEL59[2:0]	[TSEL1CR3] <INSEL79[2:0]>	- PB1 pin (TRGIN0) - PA3 pin (TRGIN1) - PN3 pin (TRGIN2) - UART ch3 Transmission completion trigger - UART ch3 Reception completion trigger - I2C ch2 interrupt - EI2C ch2 status interrupt	✓	✓	✓	✓	✓
			- TSPI ch1 Transmit complete trigger - TSPI ch1 Receive complete trigger	✓	✓	✓	✓	-

Table 2.11 Trigger selector and product table (10/15)

Register	Bit Symbol	Trigger Source	Input Trigger	Product table (✓: Available, -: N/A)					
				M3HQ	M3HP	M3HN	M3HM	M3HL	
[TSEL0CR15]	INSEL60[2:0]	T32A ch3 Timer B	- T32A ch3 Timer register A0 match trigger - T32A ch3 Timer register A1 match trigger - T32A ch3 Timer A overflow trigger - T32A ch3 Timer A underflow trigger	✓	✓	✓	✓	✓	
	INSEL61[2:0]	T32A ch3 Timer C	- T32A ch2 Timer register C0 match trigger - T32A ch2 Timer register C1 match trigger - T32A ch2 Timer C overflow trigger - T32A ch2 Timer C underflow trigger	✓	✓	✓	✓	✓	
		INSEL62[2:0]	[TSEL1CR4] <INSEL80[2:0]>	- PB1 pin (TRGIN0) - PA3 pin (TRGIN1) - PN3 pin (TRGIN2) - UART ch4 Transmission completion trigger - UART ch4 Reception completion trigger	✓	✓	✓	✓	✓
				- TSPI ch2 Transmit complete trigger - TSPI ch2 Receive complete trigger	✓	✓	✓	✓	-
				- I2C ch3 interrupt - EI2C ch3 status interrupt	✓	✓	-	-	-
	INSEL63[2:0]	T32A ch4 Timer B	- T32A ch4 Timer register A0 match trigger - T32A ch4 Timer register A1 match trigger - T32A ch4 Timer A overflow trigger - T32A ch4 Timer A underflow trigger	✓	✓	✓	✓	✓	

Table 2.12 Trigger selector and product table (11/15)

Register	Bit Symbol	Trigger Source	Input Trigger	Product table (✓: Available, -: N/A)				
				M3HQ	M3HP	M3HN	M3HM	M3HL
[TSEL1CR0]	INSEL64[2:0]	T32A ch4 Timer C	- T32A ch3 Timer register C0 match trigger - T32A ch3 Timer register C1 match trigger - T32A ch3 Timer C overflow trigger - T32A ch3 Timer C underflow trigger	✓	✓	✓	✓	✓
	INSEL65[2:0]	T32A ch5 Timer A	- PB1 pin (TRGIN0) - PA3 pin (TRGIN1) - PN3 pin (TRGIN2) - UART ch5 Transmission completion trigger - UART ch5 Reception completion trigger - A-ENC32 ch0 Dividing pulse signal	✓	✓	✓	✓	✓
			- TSPI ch3 Transmit complete trigger - TSPI ch3 Receive complete trigger	✓	✓	✓	✓	-
	INSEL66[2:0]	T32A ch5 Timer B	- T32A ch5 Timer register A0 match trigger - T32A ch5 Timer register A1 match trigger - T32A ch5 Timer A overflow trigger - T32A ch5 Timer A underflow trigger	✓	✓	✓	✓	✓
INSEL67[2:0]	T32A ch5 Timer C	- T32A ch4 Timer register C0 match trigger - T32A ch4 Timer register C1 match trigger - T32A ch4 Timer C overflow trigger - T32A ch4 Timer C underflow trigger	✓	✓	✓	✓	✓	

Table 2.13 Trigger selector and product table (12/15)

Register	Bit Symbol	Trigger Source	Input Trigger	Product table (✓: Available, -: N/A)				
				M3HQ	M3HP	M3HN	M3HM	M3HL
[TSEL1CR1]	INSEL68[2:0]	T32A ch6 Timer A	- PB1 pin (TRGIN0) - PA3 pin (TRGIN1) - PN3 pin (TRGIN2)	✓	✓	✓	✓	✓
			- TSPI ch4 Transmit completion trigger - TSPI ch4 Receive completion trigger	✓	✓	-	-	-
			- ELOSC Low speed clock	✓	✓	✓	✓	✓
	INSEL69[2:0]	T32A ch6 Timer B	- T32A ch6 Timer register A0 match trigger - T32A ch6 Timer register A1 match trigger - T32A ch6 Timer A overflow trigger - T32A ch6 Timer A underflow trigger	✓	✓	✓	✓	✓
INSEL70[2:0]	T32A ch6 Timer C	- T32A ch5 Timer register C0 match trigger - T32A ch5 Timer register C1 match trigger - T32A ch5 Timer C overflow trigger - T32A ch5 Timer C underflow trigger	✓	✓	✓	✓	✓	
INSEL71[2:0]	T32A ch7 Timer A	- PB1 pin (TRGIN0) - PA3 pin (TRGIN1) - PN3 pin (TRGIN2) - ADC unit A General purpose trigger interrupt - ADC unit A Single conversion interrupt - ADC unit A Continuous conversion interrupt - ADC unit A Monitor function interrupt 0 - ADC unit A Monitor function interrupt 1	✓	✓	✓	✓	✓	

Table 2.14 Trigger selector and product table (13/15)

Register	Bit Symbol	Trigger Source	Input Trigger	Product table (✓: Available, -: N/A)				
				M3HQ	M3HP	M3HN	M3HM	M3HL
[TSEL1CR2]	INSEL72[2:0]	T32A ch7 Timer B	- T32A ch7 Timer register A0 match trigger - T32A ch7 Timer register A1 match trigger - T32A ch7 Timer A overflow trigger - T32A ch7 Timer A underflow trigger	✓	✓	✓	✓	✓
	INSEL73[2:0]	T32A ch7 Timer C	- T32A ch6 Timer register C0 match trigger - T32A ch6 Timer register C1 match trigger - T32A ch6 Timer C overflow trigger - T32A ch6 Timer C underflow trigger	✓	✓	✓	✓	✓
	INSEL74[2:0]	UART ch6	- PB1 pin (TRGIN0) - PA3 pin (TRGIN1) - PN3 pin (TRGIN2)	✓	✓	✓	✓	✓
			- T32A ch6 Timer register A1 match trigger - T32A ch6 Timer register B1 match trigger - T32A ch6 Timer register C1 match trigger	✓	✓	✓	✓	✓
	INSEL75[2:0]	UART ch7	- PB1 pin (TRGIN0) - PA3 pin (TRGIN1) - PN3 pin (TRGIN2)	✓	✓	✓	-	-
			- T32A ch6 Timer register A1 match trigger - T32A ch6 Timer register B1 match trigger - T32A ch6 Timer register C1 match trigger	✓	✓	✓	-	-

Table 2.15 Trigger selector and product table (14/15)

Register	Bit Symbol	Trigger Source	Input Trigger	Product table (✓: Available, -: N/A)				
				M3HQ	M3HP	M3HN	M3HM	M3HL
[TSEL1CR3]	INSEL76[2:0]	T32A ch0 Timer A	- INSEL50 output	✓	✓	✓	✓	✓
			- T32A ch0 Timer register B0 match trigger - T32A ch0 Timer register B1 match trigger - T32A ch0 Timer B overflow trigger - T32A ch0 Timer B underflow trigger	✓	✓	✓	✓	✓
	INSEL77[2:0]	T32A ch1 Timer A	- INSEL53 output	✓	✓	✓	✓	✓
			- T32A ch1 Timer register B0 match trigger - T32A ch1 Timer register B1 match trigger - T32A ch1 Timer B overflow trigger - T32A ch1 Timer B underflow trigger	✓	✓	✓	✓	✓
	INSEL78[2:0]	T32A ch2 Timer A	- INSEL56 output	✓	✓	✓	✓	✓
			- T32A ch2 Timer register B0 match trigger - T32A ch2 Timer register B1 match trigger - T32A ch2 Timer B overflow trigger - T32A ch2 Timer B underflow trigger	✓	✓	✓	✓	✓
	INSEL79[2:0]	T32A ch3 Timer A	- INSEL59 output	✓	✓	✓	✓	✓
			- T32A ch3 Timer register B0 match trigger - T32A ch3 Timer register B1 match trigger - T32A ch3 Timer B overflow trigger - T32A ch3 Timer B underflow trigger	✓	✓	✓	✓	✓

Table 2.16 Trigger selector and product table (15/15)

Register	Bit Symbol	Trigger Source	Input Trigger	Product table (✓: Available, -: N/A)				
				M3HQ	M3HP	M3HN	M3HM	M3HL
[TSEL1CR4]	INSEL80[2:0]	T32A ch4 Timer A	- INSEL62 output					
			- T32A ch4 Timer register B0 match trigger - T32A ch4 Timer register B1 match trigger - T32A ch4 Timer B overflow trigger - T32A ch4 Timer B underflow trigger	✓	✓	✓	✓	✓
	INSEL81[2:0]	T32A ch5 Timer A	- INSEL65 output					
			- T32A ch5 Timer register B0 match trigger - T32A ch5 Timer register B1 match trigger - T32A ch5 Timer B overflow trigger - T32A ch5 Timer B underflow trigger	✓	✓	✓	✓	✓
	INSEL82[2:0]	T32A ch6 Timer A	- INSEL68 output	✓	✓	✓	✓	✓
			- T32A ch6 Timer register B0 match trigger - T32A ch6 Timer register B1 match trigger - T32A ch6 Timer B overflow trigger - T32A ch6 Timer B underflow trigger	✓	✓	✓	✓	✓
			- UART ch6 Transmission completion trigger - UART ch6 Reception completion trigger	✓	✓	✓	✓	✓
	INSEL83[2:0]	T32A ch7 Timer A	- INSEL71 output	✓	✓	✓	✓	✓
			- T32A ch7 Timer register B0 match trigger - T32A ch7 Timer register B1 match trigger - T32A ch7 Timer B overflow trigger - T32A ch7 Timer B underflow trigger	✓	✓	✓	✓	✓
			- UART ch7 Transmission completion trigger - UART ch7 Reception completion trigger	✓	✓	✓	-	-

2.2.2. Directions for use and setup

When you use TRGSEL, the corresponding clock enable bits should be set to "1" (Clock supply) in fsys supply stop registers A (*[CGFSYSENA]* and *[CGFSYSMENA]*), fsys supply stop registers B (*[CGFSYSENB]* and *[CGFSYSMENB]*), fsys supply stop register C (*[CGFSYSMENC]*), and fc supply stop register (*[CGFCEN]*).

The corresponding registers and the bit locations depend on a product. Some products do not have all registers. For the details, refer to the Reference manual "Clock Control and Operation Mode".

Please perform a setup of a trigger selector in the following order.

(1) Selection of an input trigger (*[TSELxCRn]*<INSELm>)

Selection of the input trigger used for the trigger source is performed.

Please set up selection of the input trigger by the input trigger sub device bit (*[TSELxCRn]*<INSELm>) of the control register. (n: register number, m: trigger number)

(2) Selection of edge detection conditions (*[TSELxCRn]*<UPDNm>)

For the input trigger signal which needs edge detection, selection of rising edge or falling edge detection is performed.

Please set up selection of edge detection conditions in the selection bit (*[TSELxCRn]*<UPDNm>) of a control register.

The following shows the trigger signal which needs edge detection. For other trigger signals, do not set to enable edge detection.

- External trigger input (TRGIN0, TRGIN1, and TRGIN2)
- ELOSC Low speed clock (fs)

(3) Selection of a trigger output (*[TSELxCRn]*<OUTSELm>)

Selection of an output without or with edge detection is performed.

Please set up selection of a trigger output in the selection bit (*[TSELxCRn]*<OUTSELm>) of a control register.

(4) Selection of trigger output enable/disable (*[TSELxCRn]*<ENm>)

The output (enable/disable) of the selected trigger signal is selected.

Please set up selection of output (enable/disable) in the setting bit (*[TSELxCRn]*<ENm>) of a control register. A trigger output will be enabled if *[TSELxCRn]*<ENm> is set to "1".

2.2.3. List of Registers

The table below shows control registers and their addresses.

Peripheral function		Channel/Unit	Base address
Trigger selector	TRGSEL	ch0	0x400BB800
		ch1	0x400BB900

Register name		Address (Base+)
Control Register0	<i>[TSELxCR0]</i>	0x0000
Control Register1	<i>[TSELxCR1]</i>	0x0004
Control Register2	<i>[TSELxCR2]</i>	0x0008
Control Register3	<i>[TSELxCR3]</i>	0x000C
Control Register4	<i>[TSELxCR4]</i>	0x0010
Control Register5	<i>[TSELxCR5]</i>	0x0014
Control Register6	<i>[TSELxCR6]</i>	0x0018
Control Register7	<i>[TSELxCR7]</i>	0x001C
Control Register8	<i>[TSELxCR8]</i>	0x0020
Control Register9	<i>[TSELxCR9]</i>	0x0024
Control Register10	<i>[TSELxCR10]</i>	0x0028
Control Register11	<i>[TSELxCR11]</i>	0x002C
Control Register12	<i>[TSELxCR12]</i>	0x0030
Control Register13	<i>[TSELxCR13]</i>	0x0034
Control Register14	<i>[TSELxCR14]</i>	0x0038
Control Register15	<i>[TSELxCR15]</i>	0x003C

2.2.4. Detail of Registers

The following chapters show the details of a register.

The sign in the functional column parenthesis of each table expresses each function signal name.

2.2.4.1. [TSEL0CR0] (Control Register 0)

Bit	Bit Symbol	After Reset	Type	Function
31	-	0	R	Read as "0"
30:28	INSEL3[2:0]	000	R/W	Selection of an input trigger (DMAC A ch18) 000: T32A ch2 DMA request at match B1 register (T32A02DMAREQCMPB1) 001: T32A ch3 DMA request at match B1 register (T32A03DMAREQCMPB1) 010: Reserved 011: Reserved 100: Reserved 101: Reserved 110: Reserved 111: Reserved
27	-	0	R	Read as "0"
26	UPDN3	0	R/W	Selection of edge detection conditions 0: Rising edge detection 1: falling edge detection
25	OUTSEL3	0	R/W	Selection of a trigger output 0: Edge detection is disabled 1: Edge detection is enabled
24	EN3	0	R/W	Setup of trigger output control 0: Disable 1: Enable
23	-	0	R	Read as "0"
22:20	INSEL2[2:0]	000	R/W	Selection of an input trigger (DMAC A ch17) 000: T32A ch0 DMA request at match B1 register (T32A00DMAREQCMPB1) 001: T32A ch1 DMA request at match B1 register (T32A01DMAREQCMPB1) 010: Reserved 011: Reserved 100: Reserved 101: Reserved 110: Reserved 111: Reserved
19	-	0	R	Read as "0"
18	UPDN2	0	R/W	Selection of edge detection conditions 0: Rising edge detection 1: falling edge detection
17	OUTSEL2	0	R/W	Selection of a trigger output 0: Edge detection is disabled 1: Edge detection is enabled
16	EN2	0	R/W	Setup of trigger output control 0: Disable 1: Enable

Bit	Bit Symbol	After Reset	Type	Function
15	-	0	R	Read as "0"
14:12	INSEL1[2:0]	000	R/W	Selection of an input trigger (DMAC A ch16) 000: T32A ch2 DMA request at match A1 register (T32A02DMAREQCPA1) 001: T32A ch2 DMA request at match C1 register (T32A02DMAREQCMPA1) 010: T32A ch3 DMA request at match A1 register (T32A03DMAREQCPA1) 011: T32A ch3 DMA request at match C1 register (T32A03DMAREQCMPA1) 100: Reserved 101: Reserved 110: Reserved 111: Reserved
11	-	0	R	Read as "0"
10	UPDN1	0	R/W	Selection of edge detection conditions 0: Rising edge detection 1: falling edge detection
9	OUTSEL1	0	R/W	Selection of a trigger output 0: Edge detection is disabled 1: Edge detection is enabled
8	EN1	0	R/W	Setup of trigger output control 0: Disable 1: Enable
7	-	0	R	Read as "0"
6:4	INSEL0[2:0]	000	R/W	Selection of an input trigger (DMAC A ch15) 000: T32A ch0 DMA request at match A1 register (T32A00DMAREQCPA1) 001: T32A ch0 DMA request at match C1 register (T32A00DMAREQCMPA1) 010: T32A ch1 DMA request at match A1 register (T32A01DMAREQCPA1) 011: T32A ch1 DMA request at match C1 register (T32A01DMAREQCMPA1) 100: Reserved 101: Reserved 110: Reserved 111: Reserved
3	-	0	R	Read as "0"
2	UPDN0	0	R/W	Selection of edge detection conditions 0: Rising edge detection 1: falling edge detection
1	OUTSEL0	0	R/W	Selection of a trigger output 0: Edge detection is disabled 1: Edge detection is enabled
0	EN0	0	R/W	Setup of trigger output control 0: Disable 1: Enable

2.2.4.2. [TSEL0CR1](Control Register 1)

Bit	Bit Symbol	After Reset	Type	Function
31	-	0	R	Read as "0"
30:28	INSEL7[2:0]	000	R/W	Selection of an input trigger (DMAC A ch22) 000: T32A ch2 DMA request at capture B0 register (T32A02DMAREQCAPB0) 001: T32A ch2 DMA request at capture B1 register (T32A02DMAREQCAPB1) 010: T32A ch3 DMA request at capture B0 register (T32A03DMAREQCAPB0) 011: T32A ch3 DMA request at capture B1 register (T32A03DMAREQCAPB1) 100: Reserved 101: Reserved 110: Reserved 111: Reserved
27	-	0	R	Read as "0"
26	UPDN7	0	R/W	Selection of edge detection conditions 0: Rising edge detection 1: falling edge detection
25	OUTSEL7	0	R/W	Selection of a trigger output 0: Edge detection is disabled 1: Edge detection is enabled
24	EN7	0	R/W	Setup of trigger output control 0: Disable 1: Enable
23	-	0	R	Read as "0"
22:20	INSEL6[2:0]	000	R/W	Selection of an input trigger (DMAC A ch21) 000: T32A ch0 DMA request at capture B0 register (T32A00DMAREQCAPB0) 001: T32A ch0 DMA request at capture B1 register (T32A00DMAREQCAPB1) 010: T32A ch1 DMA request at capture B0 register (T32A01DMAREQCAPB0) 011: T32A ch1 DMA request at capture B1 register (T32A01DMAREQCAPB1) 100: Reserved 101: Reserved 110: Reserved 111: Reserved
19	-	0	R	Read as "0"
18	UPDN6	0	R/W	Selection of edge detection conditions 0: Rising edge detection 1: falling edge detection
17	OUTSEL6	0	R/W	Selection of a trigger output 0: Edge detection is disabled 1: Edge detection is enabled
16	EN6	0	R/W	Setup of trigger output control 0: Disable 1: Enable

Bit	Bit Symbol	After Reset	Type	Function
15	-	0	R	Read as "0"
14:12	INSEL5[2:0]	000	R/W	Selection of an input trigger (DMAC A ch20) 000: T32A ch2 DMA request at capture A0 register (T32A02DMAREQCAPA0) 001: T32A ch2 DMA request at capture A1 register (T32A02DMAREQCAPA1) 010: T32A ch3 DMA request at capture A0 register (T32A03DMAREQCAPA0) 011: T32A ch3 DMA request at capture A1 register (T32A03DMAREQCAPA1) 100: T32A ch2 DMA request at capture C0 register (T32A02DMAREQCAPC0) 101: T32A ch2 DMA request at capture C1 register (T32A02DMAREQCAPC1) 110: T32A ch3 DMA request at capture C0 register (T32A03DMAREQCAPC0) 111: T32A ch3 DMA request at capture C1 register (T32A03DMAREQCAPC1)
11	-	0	R	Read as "0"
10	UPDN5	0	R/W	Selection of edge detection conditions 0: Rising edge detection 1: falling edge detection
9	OUTSEL5	0	R/W	Selection of a trigger output 0: Edge detection is disabled 1: Edge detection is enabled
8	EN5	0	R/W	Setup of trigger output control 0: Disable 1: Enable
7	-	0	R	Read as "0"
6:4	INSEL4[2:0]	000	R/W	Selection of an input trigger (DMAC A ch19) 000: T32A ch0 DMA request at capture A0 register (T32A00DMAREQCAPA0) 001: T32A ch0 DMA request at capture A1 register (T32A00DMAREQCAPA1) 010: T32A ch1 DMA request at capture A0 register (T32A01DMAREQCAPA0) 011: T32A ch1 DMA request at capture A1 register (T32A01DMAREQCAPA1) 100: T32A ch0 DMA request at capture C0 register (T32A00DMAREQCAPC0) 101: T32A ch0 DMA request at capture C1 register (T32A00DMAREQCAPC1) 110: T32A ch1 DMA request at capture C0 register (T32A01DMAREQCAPC0) 111: T32A ch1 DMA request at capture C1 register (T32A01DMAREQCAPC1)
3	-	0	R	Read as "0"
2	UPDN4	0	R/W	Selection of edge detection conditions 0: Rising edge detection 1: falling edge detection
1	OUTSEL4	0	R/W	Selection of a trigger output 0: Edge detection is disabled 1: Edge detection is enabled
0	EN4	0	R/W	Setup of trigger output control 0: Disable 1: Enable

2.2.4.3. [TSEL0CR2] (Control Register 2)

Bit	Bit Symbol	After Reset	Type	Function
31	-	0	R	Read as "0"
30:28	INSEL11[2:0]	000	R/W	Selection of an input trigger (DMAC A ch26) 000: DMAC A ch12 transmission end interrupt (INTDMAATC12) 001: DMAC A ch13 transmission end interrupt (INTDMAATC13) 010: DMAC A ch14 transmission end interrupt (INTDMAATC14) 011: Reserved 100: Reserved 101: Reserved 110: Reserved 111: Reserved
27	-	0	R	Read as "0"
26	UPDN11	0	R/W	Selection of edge detection conditions 0: Rising edge detection 1: falling edge detection
25	OUTSEL11	0	R/W	Selection of a trigger output 0: Edge detection is disabled 1: Edge detection is enabled
24	EN11	0	R/W	Setup of trigger output control 0: Disable 1: Enable
23	-	0	R	Read as "0"
22:20	INSEL10[2:0]	000	R/W	Selection of an input trigger (DMAC A ch25) 000: DMAC A ch4 transmission end interrupt (INTDMAATC4) 001: DMAC A ch5 transmission end interrupt (INTDMAATC5) 010: DMAC A ch10 transmission end interrupt (INTDMAATC10) 011: DMAC A ch11 transmission end interrupt (INTDMAATC11) 100: Reserved 101: Reserved 110: Reserved 111: Reserved
19	-	0	R	Read as "0"
18	UPDN10	0	R/W	Selection of edge detection conditions 0: Rising edge detection 1: falling edge detection
17	OUTSEL10	0	R/W	Selection of a trigger output 0: Edge detection is disabled 1: Edge detection is enabled
16	EN10	0	R/W	Setup of trigger output control 0: Disable 1: Enable

Bit	Bit Symbol	After Reset	Type	Function
15	-	0	R	Read as "0"
14:12	INSEL9[2:0]	000	R/W	Selection of an input trigger (DMAC A ch24) 000: DMAC A ch2 transmission end interrupt (INTDMAATC2) 001: DMAC A ch3 transmission end interrupt (INTDMAATC3) 010: DMAC A ch8 transmission end interrupt (INTDMAATC8) 011: DMAC A ch9 transmission end interrupt (INTDMAATC9) 100: Reserved 101: Reserved 110: Reserved 111: Reserved
11	-	0	R	Read as "0"
10	UPDN9	0	R/W	Selection of edge detection conditions 0: Rising edge detection 1: falling edge detection
9	OUTSEL9	0	R/W	Selection of a trigger output 0: Edge detection is disabled 1: Edge detection is enabled
8	EN9	0	R/W	Setup of trigger output control 0: Disable 1: Enable
7	-	0	R	Read as "0"
6:4	INSEL8[2:0]	000	R/W	Selection of an input trigger (DMAC A ch23) 000: DMAC A ch0 transmission end interrupt (INTDMAATC0) 001: DMAC A ch1 transmission end interrupt (INTDMAATC1) 010: DMAC A ch6 transmission end interrupt (INTDMAATC6) 011: DMAC A ch7 transmission end interrupt (INTDMAATC7) 100: Reserved 101: Reserved 110: Reserved 111: Reserved
3	-	0	R	Read as "0"
2	UPDN8	0	R/W	Selection of edge detection conditions 0: Rising edge detection 1: falling edge detection
1	OUTSEL8	0	R/W	Selection of a trigger output 0: Edge detection is disabled 1: Edge detection is enabled
0	EN8	0	R/W	Setup of trigger output control 0: Disable 1: Enable

2.2.4.4. [TSEL0CR3] (Control Register 3)

Bit	Bit Symbol	After Reset	Type	Function
31	-	0	R	Read as "0"
30:28	INSEL15[2:0]	000	R/W	Selection of an input trigger (DMAC A ch30) 000: DMAC A ch18 transmission end interrupt (INTDMAATC18) 001: DMAC A ch22 transmission end interrupt (INTDMAATC22) 010: Reserved 011: Reserved 100: Reserved 101: Reserved 110: Reserved 111: Reserved
27	-	0	R	Read as "0"
26	UPDN15	0	R/W	Selection of edge detection conditions 0: Rising edge detection 1: falling edge detection
25	OUTSEL15	0	R/W	Selection of a trigger output 0: Edge detection is disabled 1: Edge detection is enabled
24	EN15	0	R/W	Setup of trigger output control 0: Disable 1: Enable
23	-	0	R	Read as "0"
22:20	INSEL14[2:0]	000	R/W	Selection of an input trigger (DMAC A ch29) 000: DMAC A ch17 transmission end interrupt (INTDMAATC17) 001: DMAC A ch21 transmission end interrupt (INTDMAATC21) 010: Reserved 011: Reserved 100: Reserved 101: Reserved 110: Reserved 111: Reserved
19	-	0	R	Read as "0"
18	UPDN14	0	R/W	Selection of edge detection conditions 0: Rising edge detection 1: falling edge detection
17	OUTSEL14	0	R/W	Selection of a trigger output 0: Edge detection is disabled 1: Edge detection is enabled
16	EN14	0	R/W	Setup of trigger output control 0: Disable 1: Enable

Bit	Bit Symbol	After Reset	Type	Function
15	-	0	R	Read as "0"
14:12	INSEL13[2:0]	000	R/W	Selection of an input trigger (DMAC A ch28) 000: DMAC A ch16 transmission end interrupt (INTDMAATC16) 001: DMAC A ch20 transmission end interrupt (INTDMAATC20) 010: Reserved 011: Reserved 100: Reserved 101: Reserved 110: Reserved 111: Reserved
11	-	0	R	Read as "0"
10	UPDN13	0	R/W	Selection of edge detection conditions 0: Rising edge detection 1: falling edge detection
9	OUTSEL13	0	R/W	Selection of a trigger output 0: Edge detection is disabled 1: Edge detection is enabled
8	EN13	0	R/W	Setup of trigger output control 0: Disable 1: Enable
7	-	0	R	Read as "0"
6:4	INSEL12[2:0]	000	R/W	Selection of an input trigger (DMAC A ch27) 000: DMAC A ch15 transmission end interrupt (INTDMAATC15) 001: DMAC A ch19 transmission end interrupt (INTDMAATC19) 010: Reserved 011: Reserved 100: Reserved 101: Reserved 110: Reserved 111: Reserved
3	-	0	R	Read as "0"
2	UPDN12	0	R/W	Selection of edge detection conditions 0: Rising edge detection 1: falling edge detection
1	OUTSEL12	0	R/W	Selection of a trigger output 0: Edge detection is disabled 1: Edge detection is enabled
0	EN12	0	R/W	Setup of trigger output control 0: Disable 1: Enable

2.2.4.5. [TSEL0CR4] (Control Register 4)

Bit	Bit Symbol	After Reset	Type	Function
31	-	0	R	Read as "0"
30:28	INSEL19[2:0]	000	R/W	Selection of an input trigger (DMAC B ch14) 000: ADC unit A General purpose trigger DMA request (ADATRG_DMAREQ) 001: ADC unit A Single conversion DMA request (ADASGL_DMAREQ) 010: ADC unit A Continuous conversion DMA request (ADACNT_DMAREQ) 011: Reserved 100: Reserved 101: Reserved 110: Reserved 111: Reserved
27	-	0	R	Read as "0"
26	UPDN19	0	R/W	Selection of edge detection conditions 0: Rising edge detection 1: falling edge detection
25	OUTSEL19	0	R/W	Selection of a trigger output 0: Edge detection is disabled 1: Edge detection is enabled
24	EN19	0	R/W	Setup of trigger output control 0: Disable 1: Enable
23	-	0	R	Read as "0"
22:20	INSEL18[2:0]	000	R/W	Selection of an input trigger (DMAC B ch1) 000: TSPI ch2 Transmit DMA request (TSPI2TX_DMA) 001: EI2C/I2C ch3 Transmitting DMA request (I2C3ATXDMAREQ/I2C3TXDMAREQ) 010: Reserved 011: Reserved 100: Reserved 101: Reserved 110: Reserved 111: Reserved
19	-	0	R	Read as "0"
18	UPDN18	0	R/W	Selection of edge detection conditions 0: Rising edge detection 1: falling edge detection
17	OUTSEL18	0	R/W	Selection of a trigger output 0: Edge detection is disabled 1: Edge detection is enabled
16	EN18	0	R/W	Setup of trigger output control 0: Disable 1: Enable

Bit	Bit Symbol	After Reset	Type	Function
15	-	0	R	Read as "0"
14:12	INSEL17[2:0]	000	R/W	Selection of an input trigger (DMAC B ch0) 000: TSPI ch2 Receive DMA request (TSPI2RX_DMA) 001: EI2C/I2C ch3 Receiving DMA request (I2C3ARXDMAREQ/I2C3RXDMAREQ) 010: Reserved 011: Reserved 100: Reserved 101: Reserved 110: Reserved 111: Reserved
11	-	0	R	Read as "0"
10	UPDN17	0	R/W	Selection of edge detection conditions 0: Rising edge detection 1: falling edge detection
9	OUTSEL17	0	R/W	Selection of a trigger output 0: Edge detection is disabled 1: Edge detection is enabled
8	EN17	0	R/W	Setup of trigger output control 0: Disable 1: Enable
7	-	0	R	Read as "0"
6:4	INSEL16[2:0]	000	R/W	Selection of an input trigger (DMAC A ch31) 000: PB1 pin (TRGIN0) 001: PA3 pin (TRGIN1) 010: PN3 pin (TRGIN2) 011: Reserved 100: Reserved 101: Reserved 110: Reserved 111: Reserved When <INSEL16[2:0]> is set to "000"(PB1 pin), "001"(PA3 pin) or "010"(PN3 pin), set <OUTSEL16> to "1".
3	-	0	R	Read as "0"
2	UPDN16	0	R/W	Selection of edge detection conditions 0: Rising edge detection 1: falling edge detection
1	OUTSEL16	0	R/W	Selection of a trigger output 0: Edge detection is disabled 1: Edge detection is enabled
0	EN16	0	R/W	Setup of trigger output control 0: Disable 1: Enable

2.2.4.6. [TSEL0CR5] (Control Register 5)

Bit	Bit Symbol	After Reset	Type	Function
31	-	0	R	Read as "0"
30:28	INSEL23[2:0]	000	R/W	Selection of an input trigger (DMAC B ch18) 000: T32A ch6 DMA request at match B1 register (T32A06DMAREQCMPB1) 001: T32A ch7 DMA request at match B1 register (T32A07DMAREQCMPB1) 010: Reserved 011: Reserved 100: UART ch6 Transmission DMA request (UART6TX_DMAREQ) 101: Reserved 110: Reserved 111: Reserved
27	-	0	R	Read as "0"
26	UPDN23	0	R/W	Selection of edge detection conditions 0: Rising edge detection 1: falling edge detection
25	OUTSEL23	0	R/W	Selection of a trigger output 0: Edge detection is disabled 1: Edge detection is enabled
24	EN23	0	R/W	Setup of trigger output control 0: Disable 1: Enable
23	-	0	R	Read as "0"
22:20	INSEL22[2:0]	000	R/W	Selection of an input trigger (DMAC B ch17) 000: T32A ch4 DMA request at match B1 register (T32A04DMAREQCMPB1) 001: T32A ch5 DMA request at match B1 register (T32A05DMAREQCMPB1) 010: Reserved 011: Reserved 100: UART ch6 Reception DMA request (UART6RX_DMAREQ) 101: Reserved 110: Reserved 111: Reserved
19	-	0	R	Read as "0"
18	UPDN22	0	R/W	Selection of edge detection conditions 0: Rising edge detection 1: falling edge detection
17	OUTSEL22	0	R/W	Selection of a trigger output 0: Edge detection is disabled 1: Edge detection is enabled
16	EN22	0	R/W	Setup of trigger output control 0: Disable 1: Enable

Bit	Bit Symbol	After Reset	Type	Function
15	-	0	R	Read as "0"
14:12	INSEL21[2:0]	000	R/W	Selection of an input trigger (DMAC B ch16) 000: T32A ch6 DMA request at match A1 register (T32A06DMAREQCMPC1) 001: T32A ch6 DMA request at match C1 register (T32A06DMAREQCMPC1) 010: T32A ch7 DMA request at match A1 register (T32A07DMAREQCMPC1) 011: T32A ch7 DMA request at match C1 register (T32A07DMAREQCMPC1) 100: Reserved 101: Reserved 110: Reserved 111: Reserved
11	-	0	R	Read as "0"
10	UPDN21	0	R/W	Selection of edge detection conditions 0: Rising edge detection 1: falling edge detection
9	OUTSEL21	0	R/W	Selection of a trigger output 0: Edge detection is disabled 1: Edge detection is enabled
8	EN21	0	R/W	Setup of trigger output control 0: Disable 1: Enable
7	-	0	R	Read as "0"
6:4	INSEL20[2:0]	000	R/W	Selection of an input trigger (DMAC B ch15) 000: T32A ch4 DMA request at match A1 register (T32A04DMAREQCMPC1) 001: T32A ch4 DMA request at match C1 register (T32A04DMAREQCMPC1) 010: T32A ch5 DMA request at match A1 register (T32A05DMAREQCMPC1) 011: T32A ch5 DMA request at match C1 register (T32A05DMAREQCMPC1) 100: Reserved 101: Reserved 110: Reserved 111: Reserved
3	-	0	R	Read as "0"
2	UPDN20	0	R/W	Selection of edge detection conditions 0: Rising edge detection 1: falling edge detection
1	OUTSEL20	0	R/W	Selection of a trigger output 0: Edge detection is disabled 1: Edge detection is enabled
0	EN20	0	R/W	Setup of trigger output control 0: Disable 1: Enable

2.2.4.7. [TSEL0CR6] (Control Register 6)

Bit	Bit Symbol	After Reset	Type	Function
31	-	0	R	Read as "0"
30:28	INSEL27[2:0]	000	R/W	Selection of an input trigger (DMAC B ch22) 000: T32A ch6 DMA request at capture B0 register (T32A06DMAREQCAPB0) 001: T32A ch6 DMA request at capture B1 register (T32A06DMAREQCAPB1) 010: T32A ch7 DMA request at capture B0 register (T32A07DMAREQCAPB0) 011: T32A ch7 DMA request at capture B1 register (T32A07DMAREQCAPB1) 100: UART ch7 transmission DMA request (UART7TX_DMAREQ)(Note) 101: Reserved 110: Reserved 111: Reserved
27	-	0	R	Read as "0"
26	UPDN27	0	R/W	Selection of edge detection conditions 0: Rising edge detection 1: falling edge detection
25	OUTSEL27	0	R/W	Selection of a trigger output 0: Edge detection is disabled 1: Edge detection is enabled
24	EN27	0	R/W	Setup of trigger output control 0: Disable 1: Enable
23	-	0	R	Read as "0"
22:20	INSEL26[2:0]	000	R/W	Selection of an input trigger (DMAC B ch21) 000: T32A ch4 DMA request at capture B0 register (T32A04DMAREQCAPB0) 001: T32A ch4 DMA request at capture B1 register (T32A04DMAREQCAPB1) 010: T32A ch5 DMA request at capture B0 register (T32A05DMAREQCAPB0) 011: T32A ch5 DMA request at capture B1 register (T32A05DMAREQCAPB1) 100: UART ch7 reception DMA request (UART7RX_DMAREQ)(Note) 101: Reserved 110: Reserved 111: Reserved
19	-	0	R	Read as "0"
18	UPDN26	0	R/W	Selection of edge detection conditions 0: Rising edge detection 1: falling edge detection
17	OUTSEL26	0	R/W	Selection of a trigger output 0: Edge detection is disabled 1: Edge detection is enabled
16	EN26	0	R/W	Setup of trigger output control 0: Disable 1: Enable

Bit	Bit Symbol	After Reset	Type	Function
15	-	0	R	Read as "0"
14:12	INSEL25[2:0]	000	R/W	Selection of an input trigger (DMAC B ch20) 000: T32A ch6 DMA request at capture A0 register (T32A06DMAREQCAPA0) 001: T32A ch6 DMA request at capture A1 register (T32A06DMAREQCAPA1) 010: T32A ch7 DMA request at capture A0 register (T32A07DMAREQCAPA0) 011: T32A ch7 DMA request at capture A1 register (T32A07DMAREQCAPA1) 100: T32A ch6 DMA request at capture C0 register (T32A06DMAREQCAPC0) 101: T32A ch6 DMA request at capture C1 register (T32A06DMAREQCAPC1) 110: T32A ch7 DMA request at capture C0 register (T32A07DMAREQCAPC0) 111: T32A ch7 DMA request at capture C1 register (T32A07DMAREQCAPC1)
11	-	0	R	Read as "0"
10	UPDN25	0	R/W	Selection of edge detection conditions 0: Rising edge detection 1: falling edge detection
9	OUTSEL25	0	R/W	Selection of a trigger output 0: Edge detection is disabled 1: Edge detection is enabled
8	EN25	0	R/W	Setup of trigger output control 0: Disable 1: Enable
7	-	0	R	Read as "0"
6:4	INSEL24[2:0]	000	R/W	Selection of an input trigger (DMAC B ch19) 000: T32A ch4 DMA request at capture A0 register (T32A04DMAREQCAPA0) 001: T32A ch4 DMA request at capture A1 register (T32A04DMAREQCAPA1) 010: T32A ch5 DMA request at capture A0 register (T32A05DMAREQCAPA0) 011: T32A ch5 DMA request at capture A1 register (T32A05DMAREQCAPA1) 100: T32A ch4 DMA request at capture C0 register (T32A04DMAREQCAPC0) 101: T32A ch4 DMA request at capture C1 register (T32A04DMAREQCAPC1) 110: T32A ch5 DMA request at capture C0 register (T32A05DMAREQCAPC0) 111: T32A ch5 DMA request at capture C1 register (T32A05DMAREQCAPC1)
3	-	0	R	Read as "0"
2	UPDN24	0	R/W	Selection of edge detection conditions 0: Rising edge detection 1: falling edge detection
1	OUTSEL24	0	R/W	Selection of a trigger output 0: Edge detection is disabled 1: Edge detection is enabled
0	EN24	0	R/W	Setup of trigger output control 0: Disable 1: Enable

Note: There is no UART ch7 in M3HM and M3HL.

2.2.4.8. [TSEL0CR7](Control Register 7)

Bit	Bit Symbol	After Reset	Type	Function
31	-	0	R	Read as "0"
30:28	INSEL31[2:0]	000	R/W	Selection of an input trigger (DMAC B ch26) 000: DMAC B ch12 transmission end interrupt (INTDMABTC12) 001: DMAC B ch13 transmission end interrupt (INTDMABTC13) 010: DMAC B ch14 transmission end interrupt (INTDMABTC14) 011: Reserved 100: Reserved 101: Reserved 110: Reserved 111: Reserved
27	-	0	R	Read as "0"
26	UPDN31	0	R/W	Selection of edge detection conditions 0: Rising edge detection 1: falling edge detection
25	OUTSEL31	0	R/W	Selection of a trigger output 0: Edge detection is disabled 1: Edge detection is enabled
24	EN31	0	R/W	Setup of trigger output control 0: Disable 1: Enable
23	-	0	R	Read as "0"
22:20	INSEL30[2:0]	000	R/W	Selection of an input trigger (DMAC B ch25) 000: DMAC B ch4 transmission end interrupt (INTDMABTC4) 001: DMAC B ch5 transmission end interrupt (INTDMABTC5) 010: DMAC B ch10 transmission end interrupt (INTDMABTC10) 011: DMAC B ch11 transmission end interrupt (INTDMABTC11) 100: Reserved 101: Reserved 110: Reserved 111: Reserved
19	-	0	R	Read as "0"
18	UPDN30	0	R/W	Selection of edge detection conditions 0: Rising edge detection 1: falling edge detection
17	OUTSEL30	0	R/W	Selection of a trigger output 0: Edge detection is disabled 1: Edge detection is enabled
16	EN30	0	R/W	Setup of trigger output control 0: Disable 1: Enable

Bit	Bit Symbol	After Reset	Type	Function
15	-	0	R	Read as "0"
14:12	INSEL29[2:0]	000	R/W	Selection of an input trigger (DMAC B ch24) 000: DMAC B ch2 transmission end interrupt (INTDMABTC2) 001: DMAC B ch3 transmission end interrupt (INTDMABTC3) 010: DMAC B ch8 transmission end interrupt (INTDMABTC8) 011: DMAC B ch9 transmission end interrupt (INTDMABTC9) 100: Reserved 101: Reserved 110: Reserved 111: Reserved
11	-	0	R	Read as "0"
10	UPDN29	0	R/W	Selection of edge detection conditions 0: Rising edge detection 1: falling edge detection
9	OUTSEL29	0	R/W	Selection of a trigger output 0: Edge detection is disabled 1: Edge detection is enabled
8	EN29	0	R/W	Setup of trigger output control 0: Disable 1: Enable
7	-	0	R	Read as "0"
6:4	INSEL28[2:0]	000	R/W	Selection of an input trigger (DMAC B ch23) 000: DMAC B ch0 transmission end interrupt (INTDMABTC0) 001: DMAC B ch1 transmission end interrupt (INTDMABTC1) 010: DMAC B ch6 transmission end interrupt (INTDMABTC6) 011: DMAC B ch7 transmission end interrupt (INTDMABTC7) 100: Reserved 101: Reserved 110: Reserved 111: Reserved
3	-	0	R	Read as "0"
2	UPDN28	0	R/W	Selection of edge detection conditions 0: Rising edge detection 1: falling edge detection
1	OUTSEL28	0	R/W	Selection of a trigger output 0: Edge detection is disabled 1: Edge detection is enabled
0	EN28	0	R/W	Setup of trigger output control 0: Disable 1: Enable

2.2.4.9. [TSEL0CR8] (Control Register 8)

Bit	Bit Symbol	After Reset	Type	Function
31	-	0	R	Read as "0"
30:28	INSEL35[2:0]	000	R/W	Selection of an input trigger (DMAC B ch30) 000: DMAC B ch18 transmission end interrupt (INTDMABTC18) 001: DMAC B ch22 transmission end interrupt (INTDMABTC22) 010: Reserved 011: Reserved 100: Reserved 101: Reserved 110: Reserved 111: Reserved
27	-	0	R	Read as "0"
26	UPDN35	0	R/W	Selection of edge detection conditions 0: Rising edge detection 1: falling edge detection
25	OUTSEL35	0	R/W	Selection of a trigger output 0: Edge detection is disabled 1: Edge detection is enabled
24	EN35	0	R/W	Setup of trigger output control 0: Disable 1: Enable
23	-	0	R	Read as "0"
22:20	INSEL34[2:0]	000	R/W	Selection of an input trigger (DMAC B ch29) 000: DMAC B ch17 transmission end interrupt (INTDMABTC17) 001: DMAC B ch21 transmission end interrupt (INTDMABTC21) 010: Reserved 011: Reserved 100: Reserved 101: Reserved 110: Reserved 111: Reserved
19	-	0	R	Read as "0"
18	UPDN34	0	R/W	Selection of edge detection conditions 0: Rising edge detection 1: falling edge detection
17	OUTSEL34	0	R/W	Selection of a trigger output 0: Edge detection is disabled 1: Edge detection is enabled
16	EN34	0	R/W	Setup of trigger output control 0: Disable 1: Enable

Bit	Bit Symbol	After Reset	Type	Function
15	-	0	R	Read as "0"
14:12	INSEL33[2:0]	000	R/W	Selection of an input trigger (DMAC B ch28) 000: DMAC B ch16 transmission end interrupt (INTDMABTC16) 001: DMAC B ch20 transmission end interrupt (INTDMABTC20) 010: Reserved 011: Reserved 100: Reserved 101: Reserved 110: Reserved 111: Reserved
11	-	0	R	Read as "0"
10	UPDN33	0	R/W	Selection of edge detection conditions 0: Rising edge detection 1: falling edge detection
9	OUTSEL33	0	R/W	Selection of a trigger output 0: Edge detection is disabled 1: Edge detection is enabled
8	EN33	0	R/W	Setup of trigger output control 0: Disable 1: Enable
7	-	0	R	Read as "0"
6:4	INSEL32[2:0]	000	R/W	Selection of an input trigger (DMAC B ch27) 000: DMAC B ch15 transmission end interrupt (INTDMABTC15) 001: DMAC B ch19 transmission end interrupt (INTDMABTC19) 010: Reserved 011: Reserved 100: Reserved 101: Reserved 110: Reserved 111: Reserved
3	-	0	R	Read as "0"
2	UPDN32	0	R/W	Selection of edge detection conditions 0: Rising edge detection 1: falling edge detection
1	OUTSEL32	0	R/W	Selection of a trigger output 0: Edge detection is disabled 1: Edge detection is enabled
0	EN32	0	R/W	Setup of trigger output control 0: Disable 1: Enable

2.2.4.10. [TSEL0CR9] (Control Register 9)

Bit	Bit Symbol	After Reset	Type	Function
31	-	0	R	Read as "0"
30:28	INSEL39[2:0]	000	R/W	Selection of an input trigger (TSPI ch0) 000: PB1 pin (TRGIN0) 001: PA3 pin (TRGIN1) 010: PN3 pin (TRGIN2) 011: T32A ch6 Timer register A1 match trigger (T32A06TRGOUTCMPA1) 100: T32A ch6 Timer register B1 match trigger (T32A06TRGOUTCMPB1) 101: T32A ch6 Timer register C1 match trigger (T32A06TRGOUTCMPC1) 110: Reserved 111: Reserved When <INSEL39[2:0]> is set to "000"(PB1 pin), "001"(PA3 pin) or "010"(PN3 pin), set <OUTSEL39> to "1".
27	-	0	R	Read as "0"
26	UPDN39	0	R/W	Selection of edge detection conditions 0: Rising edge detection 1: falling edge detection
25	OUTSEL39	0	R/W	Selection of a trigger output 0: Edge detection is disabled 1: Edge detection is enabled
24	EN39	0	R/W	Setup of trigger output control 0: Disable 1: Enable
23	-	0	R	Read as "0"
22:20	INSEL38[2:0]	000	R/W	Selection of an input trigger (ADC general purpose trigger) 000: PB1 pin (TRGIN0) 001: PA3 pin (TRGIN1) 010: PN3 pin (TRGIN2) 011: T32A ch7 Timer register A1 match trigger (T32A07TRGOUTCMPA1) 100: T32A ch7 Timer register B1 match trigger (T32A07TRGOUTCMPB1) 101: T32A ch7 Timer register C1 match trigger (T32A07TRGOUTCMPC1) 110: Reserved 111: Reserved When <INSEL38[2:0]> is set to "000"(PB1 pin), "001"(PA3 pin) or "010"(PN3 pin), set <OUTSEL38> to "1".
19	-	0	R	Read as "0"
18	UPDN38	0	R/W	Selection of edge detection conditions 0: Rising edge detection 1: falling edge detection
17	OUTSEL38	0	R/W	Selection of a trigger output 0: Edge detection is disabled 1: Edge detection is enabled
16	EN38	0	R/W	Setup of trigger output control 0: Disable 1: Enable

Bit	Bit Symbol	After Reset	Type	Function
15	-	0	R	Read as "0"
14:12	INSEL37[2:0]	000	R/W	<p>Selection of an input trigger (PMDTRG6 of ADC)</p> <p>000: PB1 pin (TRGIN0) 001: PA3 pin (TRGIN1) 010: PN3 pin (TRGIN2) 011: T32A ch7 Timer register A1 match trigger (T32A07TRGOUTCMPA1) 100: T32A ch7 Timer register B1 match trigger (T32A07TRGOUTCMPB1) 101: T32A ch7 Timer register C1 match trigger (T32A07TRGOUTCMPC1) 110: Reserved 111: Reserved</p> <p>When <INSEL37[2:0]> is set to "000"(PB1 pin), "001"(PA3 pin) or "010"(PN3 pin), set <OUTSEL37> to "1".</p>
11	-	0	R	Read as "0"
10	UPDN37	0	R/W	<p>Selection of edge detection conditions</p> <p>0: Rising edge detection 1: falling edge detection</p>
9	OUTSEL37	0	R/W	<p>Selection of a trigger output</p> <p>0: Edge detection is disabled 1: Edge detection is enabled</p>
8	EN37	0	R/W	<p>Setup of trigger output control</p> <p>0: Disable 1: Enable</p>
7	-	0	R	Read as "0"
6:4	INSEL36[2:0]	000	R/W	<p>Selection of an input trigger (DMAC B ch31)</p> <p>000: PB1 pin (TRGIN0) 001: PA3 pin (TRGIN1) 010: PN3 pin (TRGIN2) 011: Reserved 100: Reserved 101: Reserved 110: Reserved 111: Reserved</p> <p>When <INSEL36[2:0]> is set to "000"(PB1 pin), "001"(PA3 pin) or "010"(PN3 pin), set <OUTSEL36> to "1".</p>
3	-	0	R	Read as "0"
2	UPDN36	0	R/W	<p>Selection of edge detection conditions</p> <p>0: Rising edge detection 1: falling edge detection</p>
1	OUTSEL36	0	R/W	<p>Selection of a trigger output</p> <p>0: Edge detection is disabled 1: Edge detection is enabled</p>
0	EN36	0	R/W	<p>Setup of trigger output control</p> <p>0: Disable 1: Enable</p>

2.2.4.11. [TSEL0CR10] (Control Register 10)

Bit	Bit Symbol	After Reset	Type	Function
31	-	0	R	Read as "0"
30:28	INSEL43[2:0]	000	R/W	<p>Selection of an input trigger (TSPI ch4)</p> <p>000: PB1 pin (TRGIN0) 001: PA3 pin (TRGIN1) 010: PN3 pin (TRGIN2) 011: T32A ch6 Timer register A1 match trigger (T32A06TRGOUTCMPA1) 100: T32A ch6 Timer register B1 match trigger (T32A06TRGOUTCMPB1) 101: T32A ch6 Timer register C1 match trigger (T32A06TRGOUTCMPC1) 110: Reserved 111: Reserved</p> <p>When <INSEL43[2:0]> is set to "000"(PB1 pin), "001"(PA3 pin) or "010"(PN3 pin), set <OUTSEL43> to "1".</p>
27	-	0	R	Read as "0"
26	UPDN43	0	R/W	<p>Selection of edge detection conditions</p> <p>0: Rising edge detection 1: falling edge detection</p>
25	OUTSEL43	0	R/W	<p>Selection of a trigger output</p> <p>0: Edge detection is disabled 1: Edge detection is enabled</p>
24	EN43	0	R/W	<p>Setup of trigger output control</p> <p>0: Disable 1: Enable</p>
23	-	0	R	Read as "0"
22:20	INSEL42[2:0]	000	R/W	<p>Selection of an input trigger (TSPI ch3)</p> <p>000: PB1 pin (TRGIN0) 001: PA3 pin (TRGIN1) 010: PN3 pin (TRGIN2) 011: T32A ch6 Timer register A1 match trigger (T32A06TRGOUTCMPA1) 100: T32A ch6 Timer register B1 match trigger (T32A06TRGOUTCMPB1) 101: T32A ch6 Timer register C1 match trigger (T32A06TRGOUTCMPC1) 110: Reserved 111: Reserved</p> <p>When <INSEL42[2:0]> is set to "000"(PB1 pin), "001"(PA3 pin) or "010"(PN3 pin), set <OUTSEL42> to "1".</p>
19	-	0	R	Read as "0"
18	UPDN42	0	R/W	<p>Selection of edge detection conditions</p> <p>0: Rising edge detection 1: falling edge detection</p>
17	OUTSEL42	0	R/W	<p>Selection of a trigger output</p> <p>0: Edge detection is disabled 1: Edge detection is enabled</p>
16	EN42	0	R/W	<p>Setup of trigger output control</p> <p>0: Disable 1: Enable</p>

Bit	Bit Symbol	After Reset	Type	Function
15	-	0	R	Read as "0"
14:12	INSEL41[2:0]	000	R/W	<p>Selection of an input trigger (TSPI ch2)</p> <p>000: PB1 pin (TRGIN0) 001: PA3 pin (TRGIN1) 010: PN3 pin (TRGIN2) 011: T32A ch6 Timer register A1 match trigger (T32A06TRGOUTCMPA1) 100: T32A ch6 Timer register B1 match trigger (T32A06TRGOUTCMPB1) 101: T32A ch6 Timer register C1 match trigger (T32A06TRGOUTCMPC1) 110: Reserved 111: Reserved</p> <p>When <INSEL41[2:0]> is set to "000"(PB1 pin)," 001"(PA3 pin) or "010"(PN3 pin), set <OUTSEL41> to "1".</p>
11	-	0	R	Read as "0"
10	UPDN41	0	R/W	<p>Selection of edge detection conditions</p> <p>0: Rising edge detection 1: falling edge detection</p>
9	OUTSEL41	0	R/W	<p>Selection of a trigger output</p> <p>0: Edge detection is disabled 1: Edge detection is enabled</p>
8	EN41	0	R/W	<p>Setup of trigger output control</p> <p>0: Disable 1: Enable</p>
7	-	0	R	Read as "0"
6:4	INSEL40[2:0]	000	R/W	<p>Selection of an input trigger (TSPI ch1)</p> <p>000: PB1 pin (TRGIN0) 001: PA3 pin (TRGIN1) 010: PN3 pin (TRGIN2) 011: T32A ch6 Timer register A1 match trigger (T32A06TRGOUTCMPA1) 100: T32A ch6 Timer register B1 match trigger (T32A06TRGOUTCMPB1) 101: T32A ch6 Timer register C1 match trigger (T32A06TRGOUTCMPC1) 110: Reserved 111: Reserved</p> <p>When <INSEL40[2:0]> is set to "000"(PB1 pin)," 001"(PA3 pin) or "010"(PN3 pin), set <OUTSEL40> to "1".</p>
3	-	0	R	Read as "0"
2	UPDN40	0	R/W	<p>Selection of edge detection conditions</p> <p>0: Rising edge detection 1: falling edge detection</p>
1	OUTSEL40	0	R/W	<p>Selection of a trigger output</p> <p>0: Edge detection is disabled 1: Edge detection is enabled</p>
0	EN40	0	R/W	<p>Setup of trigger output control</p> <p>0: Disable 1: Enable</p>

2.2.4.12. [TSEL0CR11] (Control Register 11)

Bit	Bit Symbol	After Reset	Type	Function
31	-	0	R	Read as "0"
30:28	INSEL47[2:0]	000	R/W	Selection of an input trigger (UART ch3) 000: PB1 pin (TRGIN0) 001: PA3 pin (TRGIN1) 010: PN3 pin (TRGIN2) 011: T32A ch6 Timer register A1 match trigger (T32A06TRGOUTCMPA1) 100: T32A ch6 Timer register B1 match trigger (T32A06TRGOUTCMPB1) 101: T32A ch6 Timer register C1 match trigger (T32A06TRGOUTCMPC1) 110: Reserved 111: Reserved When <INSEL47[2:0]> is set to "000"(PB1 pin)," 001"(PA3 pin) or "010"(PN3 pin), set <OUTSEL47> to "1".
27	-	0	R	Read as "0"
26	UPDN47	0	R/W	Selection of edge detection conditions 0: Rising edge detection 1: falling edge detection
25	OUTSEL47	0	R/W	Selection of a trigger output 0: Edge detection is disabled 1: Edge detection is enabled
24	EN47	0	R/W	Setup of trigger output control 0: Disable 1: Enable
23	-	0	R	Read as "0"
22:20	INSEL46[2:0]	000	R/W	Selection of an input trigger (UART ch2) 000: PB1 pin (TRGIN0) 001: PA3 pin (TRGIN1) 010: PN3 pin (TRGIN2) 011: T32A ch6 Timer register A1 match trigger (T32A06TRGOUTCMPA1) 100: T32A ch6 Timer register B1 match trigger (T32A06TRGOUTCMPB1) 101: T32A ch6 Timer register C1 match trigger (T32A06TRGOUTCMPC1) 110: Reserved 111: Reserved When <INSEL46[2:0]> is set to "000"(PB1 pin)," 001"(PA3 pin) or "010"(PN3 pin), set <OUTSEL46> to "1".
19	-	0	R	Read as "0"
18	UPDN46	0	R/W	Selection of edge detection conditions 0: Rising edge detection 1: falling edge detection
17	OUTSEL46	0	R/W	Selection of a trigger output 0: Edge detection is disabled 1: Edge detection is enabled
16	EN46	0	R/W	Setup of trigger output control 0: Disable 1: Enable

Bit	Bit Symbol	After Reset	Type	Function
15	-	0	R	Read as "0"
14:12	INSEL45[2:0]	000	R/W	<p>Selection of an input trigger (UART ch1)</p> <p>000: PB1 pin (TRGIN0) 001: PA3 pin (TRGIN1) 010: PN3 pin (TRGIN2) 011: T32A ch6 Timer register A1 match trigger (T32A06TRGOUTCMPA1) 100: T32A ch6 Timer register B1 match trigger (T32A06TRGOUTCMPB1) 101: T32A ch6 Timer register C1 match trigger (T32A06TRGOUTCMPC1) 110: Reserved 111: Reserved</p> <p>When <INSEL45[2:0]> is set to "000"(PB1 pin), "001"(PA3 pin) or "010"(PN3 pin), set <OUTSEL45> to "1".</p>
11	-	0	R	Read as "0"
10	UPDN45	0	R/W	<p>Selection of edge detection conditions</p> <p>0: Rising edge detection 1: falling edge detection</p>
9	OUTSEL45	0	R/W	<p>Selection of a trigger output</p> <p>0: Edge detection is disabled 1: Edge detection is enabled</p>
8	EN45	0	R/W	<p>Setup of trigger output control</p> <p>0: Disable 1: Enable</p>
7	-	0	R	Read as "0"
6:4	INSEL44[2:0]	000	R/W	<p>Selection of an input trigger (UART ch0)</p> <p>000: PB1 pin (TRGIN0) 001: PA3 pin (TRGIN1) 010: PN3 pin (TRGIN2) 011: T32A ch6 Timer register A1 match trigger (T32A06TRGOUTCMPA1) 100: T32A ch6 Timer register B1 match trigger (T32A06TRGOUTCMPB1) 101: T32A ch6 Timer register C1 match trigger (T32A06TRGOUTCMPC1) 110: Reserved 111: Reserved</p> <p>When <INSEL44[2:0]> is set to "000"(PB1 pin), "001"(PA3 pin) or "010"(PN3 pin), set <OUTSEL44> to "1".</p>
3	-	0	R	Read as "0"
2	UPDN44	0	R/W	<p>Selection of edge detection conditions</p> <p>0: Rising edge detection 1: falling edge detection</p>
1	OUTSEL44	0	R/W	<p>Selection of a trigger output</p> <p>0: Edge detection is disabled 1: Edge detection is enabled</p>
0	EN44	0	R/W	<p>Setup of trigger output control</p> <p>0: Disable 1: Enable</p>

2.2.4.13. [TSEL0CR12] (Control Register 12)

Bit	Bit Symbol	After Reset	Type	Function
31	-	0	R	Read as "0"
30:28	INSEL51[2:0]	000	R/W	Selection of an input trigger (T32A ch0 Timer B) 000: T32A ch0 Timer register A0 match trigger (T32A00TRGOUTCMPA0) 001: T32A ch0 Timer register A1 match trigger (T32A00TRGOUTCMPA1) 010: T32A ch0 Timer A overflow trigger (T32A00TRGOUTOFA) 011: T32A ch0 Timer A underflow trigger (T32A00TRGOUTUFA) 100: Reserved 101: Reserved 110: Reserved 111: Reserved
27	-	0	R	Read as "0"
26	UPDN51	0	R/W	Selection of edge detection conditions 0: Rising edge detection 1: falling edge detection
25	OUTSEL51	0	R/W	Selection of a trigger output 0: Edge detection is disabled 1: Edge detection is enabled
24	EN51	0	R/W	Setup of trigger output control 0: Disable 1: Enable
23	-	0	R	Read as "0"
22:20	INSEL50[2:0]	000	R/W	Selection of an input trigger (INSEL76) 000: PB1 pin (TRGIN0) 001: PA3 pin (TRGIN1) 010: PN3 pin (TRGIN2) 011: UART ch0 Transmission completion trigger (UART0TXTRG) 100: UART ch0 Reception completion trigger (UART0RXTRG) 101: Reserved 110: Reserved 111: Reserved When <INSEL50[2:0]> is set to "000"(PB1 pin), "001"(PA3 pin) or "010"(PN3 pin), set <OUTSEL50> to "1".
19	-	0	R	Read as "0"
18	UPDN50	0	R/W	Selection of edge detection conditions 0: Rising edge detection 1: falling edge detection
17	OUTSEL50	0	R/W	Selection of a trigger output 0: Edge detection is disabled 1: Edge detection is enabled
16	EN50	0	R/W	Setup of trigger output control 0: Disable 1: Enable

Bit	Bit Symbol	After Reset	Type	Function
15	-	0	R	Read as "0"
14:12	INSEL49[2:0]	000	R/W	<p>Selection of an input trigger (UART ch5)</p> <p>000: PB1 pin (TRGIN0) 001: PA3 pin (TRGIN1) 010: PN3 pin (TRGIN2) 011: T32A ch6 Timer register A1 match trigger (T32A06TRGOUTCMPA1) 100: T32A ch6 Timer register B1 match trigger (T32A06TRGOUTCMPB1) 101: T32A ch6 Timer register C1 match trigger (T32A06TRGOUTCMPC1) 110: Reserved 111: Reserved</p> <p>When <INSEL49[2:0]> is set to "000"(PB1 pin),"001"(PA3 pin) or "010"(PN3 pin), set <OUTSEL49> to "1".</p>
11	-	0	R	Read as "0"
10	UPDN49	0	R/W	<p>Selection of edge detection conditions</p> <p>0: Rising edge detection 1: falling edge detection</p>
9	OUTSEL49	0	R/W	<p>Selection of a trigger output</p> <p>0: Edge detection is disabled 1: Edge detection is enabled</p>
8	EN49	0	R/W	<p>Setup of trigger output control</p> <p>0: Disable 1: Enable</p>
7	-	0	R	Read as "0"
6:4	INSEL48[2:0]	000	R/W	<p>Selection of an input trigger (UART ch4)</p> <p>000: PB1 pin (TRGIN0) 001: PA3 pin (TRGIN1) 010: PN3 pin (TRGIN2) 011: T32A ch6 Timer register A1 match trigger (T32A06TRGOUTCMPA1) 100: T32A ch6 Timer register B1 match trigger (T32A06TRGOUTCMPB1) 101: T32A ch6 Timer register C1 match trigger (T32A06TRGOUTCMPC1) 110: Reserved 111: Reserved</p> <p>When <INSEL48[2:0]> is set to "000"(PB1 pin),"001"(PA3 pin) or "010"(PN3 pin), set <OUTSEL48> to "1".</p>
3	-	0	R	Read as "0"
2	UPDN48	0	R/W	<p>Selection of edge detection conditions</p> <p>0: Rising edge detection 1: falling edge detection</p>
1	OUTSEL48	0	R/W	<p>Selection of a trigger output</p> <p>0: Edge detection is disabled 1: Edge detection is enabled</p>
0	EN48	0	R/W	<p>Setup of trigger output control</p> <p>0: Disable 1: Enable</p>

2.2.4.14. [TSEL0CR13] (Control Register 13)

Bit	Bit Symbol	After Reset	Type	Function
31	-	0	R	Read as "0"
30:28	INSEL55[2:0]	000	R/W	Selection of an input trigger (T32A ch1 Timer C) 000: T32A ch0 Timer register C0 match trigger (T32A00TRGOUTCMPC0) 001: T32A ch0 Timer register C1 match trigger (T32A00TRGOUTCMPC1) 010: T32A ch0 Timer C overflow trigger (T32A00TRGOUTOFC) 011: T32A ch0 Timer C underflow trigger (T32A00TRGOUTUFC) 100: Reserved 101: Reserved 110: Reserved 111: Reserved
27	-	0	R	Read as "0"
26	UPDN55	0	R/W	Selection of edge detection conditions 0: Rising edge detection 1: falling edge detection
25	OUTSEL55	0	R/W	Selection of a trigger output 0: Edge detection is disabled 1: Edge detection is enabled
24	EN55	0	R/W	Setup of trigger output control 0: Disable 1: Enable
23	-	0	R	Read as "0"
22:20	INSEL54[2:0]	000	R/W	Selection of an input trigger (T32A ch1 Timer B) 000: T32A ch1 Timer register A0 match trigger (T32A01TRGOUTCMPA0) 001: T32A ch1 Timer register A1 match trigger (T32A01TRGOUTCMPA1) 010: T32A ch1 Timer A overflow trigger (T32A01TRGOUTOFA) 011: T32A ch1 Timer A underflow trigger (T32A01TRGOUTUFA) 100: Reserved 101: Reserved 110: Reserved 111: Reserved
19	-	0	R	Read as "0"
18	UPDN54	0	R/W	Selection of edge detection conditions 0: Rising edge detection 1: falling edge detection
17	OUTSEL54	0	R/W	Selection of a trigger output 0: Edge detection is disabled 1: Edge detection is enabled
16	EN54	0	R/W	Setup of trigger output control 0: Disable 1: Enable

Bit	Bit Symbol	After Reset	Type	Function
15	-	0	R	Read as "0"
14:12	INSEL53[2:0]	000	R/W	Selection of an input trigger (INSEL77) 000: PB1 pin (TRGIN0) 001: PA3 pin (TRGIN1) 010: PN3 pin (TRGIN2) 011: UART ch1 Transmission completion trigger (UART1TXTRG) 100: UART ch1 Reception completion trigger (UART1RXTRG) 101: EI2C ch0 status Interrupt (INTI2C0ST)/I2C ch0 interrupt (INTI2C0) 110: Reserved 111: Reserved When <INSEL53[2:0]> is set to "000"(PB1 pin),"001"(PA3 pin) or "010"(PN3 pin), set <OUTSEL53> to "1".
11	-	0	R	Read as "0"
10	UPDN53	0	R/W	Selection of edge detection conditions 0: Rising edge detection 1: falling edge detection
9	OUTSEL53	0	R/W	Selection of a trigger output 0: Edge detection is disabled 1: Edge detection is enabled
8	EN53	0	R/W	Setup of trigger output control 0: Disable 1: Enable
7	-	0	R	Read as "0"
6:4	INSEL52[2:0]	000	R/W	Selection of an input trigger (T32A ch0 Timer C) 000: T32A ch7 Timer register C0 match trigger (T32A07TRGOUTCMPC0) 001: T32A ch7 Timer register C1 match trigger (T32A07TRGOUTCMPC1) 010: T32A ch7 Timer C overflow trigger (T32A07TRGOUTOFC) 011: T32A ch7 Timer C underflow trigger (T32A07TRGOUTUFC) 100: Reserved 101: Reserved 110: Reserved 111: Reserved
3	-	0	R	Read as "0"
2	UPDN52	0	R/W	Selection of edge detection conditions 0: Rising edge detection 1: falling edge detection
1	OUTSEL52	0	R/W	Selection of a trigger output 0: Edge detection is disabled 1: Edge detection is enabled
0	EN52	0	R/W	Setup of trigger output control 0: Disable 1: Enable

2.2.4.15. [TSEL0CR14] (Control Register 14)

Bit	Bit Symbol	After Reset	Type	Function
31	-	0	R	Read as "0"
30:28	INSEL59[2:0]	000	R/W	Selection of an input trigger (INSEL79) 000: PB1 pin (TRGIN0) 001: PA3 pin (TRGIN1) 010: PN3 pin (TRGIN2) 011: UART ch3 Transmission completion trigger (UART3TXTRG) 100: UART ch3 Reception completion trigger (UART3RXTRG) 101: TSPI ch1 transmit complete trigger (TSPI1TXEND) 110: TSPI ch1 receive complete trigger (TSPI1RXEND) 111: I2C ch2 status interrupt (INTI2C2ST)/I2C ch2 interrupt (INTI2C2) When <INSEL59[2:0]> is set to "000"(PB1 pin),"001"(PA3 pin), or "010"(PN3 pin), set <OUTSEL59> to "1".
27	-	0	R	Read as "0"
26	UPDN59	0	R/W	Selection of edge detection conditions 0: Rising edge detection 1: falling edge detection
25	OUTSEL59	0	R/W	Selection of a trigger output 0: Edge detection is disabled 1: Edge detection is enabled
24	EN59	0	R/W	Setup of trigger output control 0: Disable 1: Enable
23	-	0	R	Read as "0"
22:20	INSEL58[2:0]	000	R/W	Selection of an input trigger (T32A ch2 Timer C) 000: T32A ch1 Timer register C0 match trigger (T32A01TRGOUTCMPC0) 001: T32A ch1 Timer register C1 match trigger (T32A01TRGOUTCMPC1) 010: T32A ch1 Timer C overflow trigger (T32A01TRGOUTOFC) 011: T32A ch1 Timer C underflow trigger (T32A01TRGOUTUFC) 100: Reserved 101: Reserved 110: Reserved 111: Reserved
19	-	0	R	Read as "0"
18	UPDN58	0	R/W	Selection of edge detection conditions 0: Rising edge detection 1: falling edge detection
17	OUTSEL58	0	R/W	Selection of a trigger output 0: Edge detection is disabled 1: Edge detection is enabled
16	EN58	0	R/W	Setup of trigger output control 0: Disable 1: Enable

Bit	Bit Symbol	After Reset	Type	Function
15	-	0	R	Read as "0"
14:12	INSEL57[2:0]	000	R/W	Selection of an input trigger (T32A ch2 Timer B) 000: T32A ch2 Timer register A0 match trigger (T32A02TRGOUTCMPA0) 001: T32A ch2 Timer register A1 match trigger (T32A02TRGOUTCMPA1) 010: T32A ch2 Timer A overflow trigger (T32A02TRGOUTOFA) 011: T32A ch2 Timer A underflow trigger (T32A02TRGOUTUFA) 100: Reserved 101: Reserved 110: Reserved 111: Reserved
11	-	0	R	Read as "0"
10	UPDN57	0	R/W	Selection of edge detection conditions 0: Rising edge detection 1: falling edge detection
9	OUTSEL57	0	R/W	Selection of a trigger output 0: Edge detection is disabled 1: Edge detection is enabled
8	EN57	0	R/W	Setup of trigger output control 0: Disable 1: Enable
7	-	0	R	Read as "0"
6:4	INSEL56[2:0]	000	R/W	Selection of an input trigger (INSEL78) 000: PB1 pin (TRGIN0) 001: PA3 pin (TRGIN1) 010: PN3 pin (TRGIN2) 011: UART ch2 Transmission completion trigger (UART2TXTRG) 100: UART ch2 Reception completion trigger (UART2RXTRG) 101: TSPI ch0 transmit complete trigger (TSPI0TXEND) 110: TSPI ch0 receive complete trigger (TSPI0RXEND) 111: EI2C ch1 status interrupt (INTI2C1ST)/I2C ch1 interrupt (INTI2C1)(Note) When <INSEL56[2:0]> is set to "000"(PB1 pin), "001"(PA3 pin), or "010"(PN3 pin), set <OUTSEL56> to "1".
3	-	0	R	Read as "0"
2	UPDN56	0	R/W	Selection of edge detection conditions 0: Rising edge detection 1: falling edge detection
1	OUTSEL56	0	R/W	Selection of a trigger output 0: Edge detection is disabled 1: Edge detection is enabled
0	EN56	0	R/W	Setup of trigger output control 0: Disable 1: Enable

Note: There is no EI2C/I2C ch1 in M3HL.

2.2.4.16. [TSEL0CR15] (Control Register 15)

Bit	Bit Symbol	After Reset	Type	Function
31	-	0	R	Read as "0"
30:28	INSEL63[2:0]	000	R/W	Selection of an input trigger (T32A ch4 Timer B) 000: T32A ch4 Timer register A0 match trigger (T32A04TRGOUTCMPA0) 001: T32A ch4 Timer register A1 match trigger (T32A04TRGOUTCMPA1) 010: T32A ch4 Timer A overflow trigger (T32A04TRGOUTOFA) 011: T32A ch4 Timer A underflow trigger (T32A04TRGOUTUFA) 100: Reserved 101: Reserved 110: Reserved 111: Reserved
27	-	0	R	Read as "0"
26	UPDN63	0	R/W	Selection of edge detection conditions 0: Rising edge detection 1: falling edge detection
25	OUTSEL63	0	R/W	Selection of a trigger output 0: Edge detection is disabled 1: Edge detection is enabled
24	EN63	0	R/W	Setup of trigger output control 0: Disable 1: Enable
23	-	0	R	Read as "0"
22:20	INSEL62[2:0]	000	R/W	Selection of an input trigger (INSEL80) 000: PB1 pin (TRGIN0) 001: PA3 pin (TRGIN1) 010: PN3 pin (TRGIN2) 011: UART ch4 Transmission completion trigger (UART4TXTRG) 100: UART ch4 Reception completion trigger (UART4RXTRG) 101: TSPI ch2 transmit complete trigger (TSPI2TXEND) 110: TSPI ch2 receive complete trigger (TSPI2RXEND) 111: EI2C ch3 status interrupt (INTI2C3ST)/I2C ch3 interrupt (INTI2C3)(Note) When <INSEL62[2:0]> is set to "000"(PB1 pin),"001"(PA3 pin), or "010"(PN3 pin), set <OUTSEL62> to "1".
19	-	0	R	Read as "0"
18	UPDN62	0	R/W	Selection of edge detection conditions 0: Rising edge detection 1: falling edge detection
17	OUTSEL62	0	R/W	Selection of a trigger output 0: Edge detection is disabled 1: Edge detection is enabled
16	EN62	0	R/W	Setup of trigger output control 0: Disable 1: Enable

Note: There is no EI2C/I2C ch3 in M3HN, M3HM, and M3HL.

Bit	Bit Symbol	After Reset	Type	Function
15	-	0	R	Read as "0"
14:12	INSEL61[2:0]	000	R/W	Selection of an input trigger (T32A ch3 Timer C) 000: T32A ch2 Timer register C0 match trigger (T32A02TRGOUTCMPC0) 001: T32A ch2 Timer register C1 match trigger (T32A02TRGOUTCMPC1) 010: T32A ch2 Timer C overflow trigger (T32A02TRGOUTOFC) 011: T32A ch2 Timer C underflow trigger (T32A02TRGOUTUFC) 100: Reserved 101: Reserved 110: Reserved 111: Reserved
11	-	0	R	Read as "0"
10	UPDN61	0	R/W	Selection of edge detection conditions 0: Rising edge detection 1: falling edge detection
9	OUTSEL61	0	R/W	Selection of a trigger output 0: Edge detection is disabled 1: Edge detection is enabled
8	EN61	0	R/W	Setup of trigger output control 0: Disable 1: Enable
7	-	0	R	Read as "0"
6:4	INSEL60[2:0]	000	R/W	Selection of an input trigger (T32A ch3 Timer B) 000: T32A ch3 Timer register A0 match trigger (T32A03TRGOUTCMPA0) 001: T32A ch3 Timer register A1 match trigger (T32A03TRGOUTCMPA1) 010: T32A ch3 Timer A overflow trigger (T32A03TRGOUTOFA) 011: T32A ch3 Timer A underflow trigger (T32A03TRGOUTUFA) 100: Reserved 101: Reserved 110: Reserved 111: Reserved
3	-	0	R	Read as "0"
2	UPDN60	0	R/W	Selection of edge detection conditions 0: Rising edge detection 1: falling edge detection
1	OUTSEL60	0	R/W	Selection of a trigger output 0: Edge detection is disabled 1: Edge detection is enabled
0	EN60	0	R/W	Setup of trigger output control 0: Disable 1: Enable

2.2.4.17. [TSEL1CR0] (Control Register 0)

Bit	Bit Symbol	After Reset	Type	Function
31	-	0	R	Read as "0"
30:28	INSEL3[2:0] (INSEL67[2:0])	000	R/W	Selection of an input trigger (T32A ch5 Timer C) 000: T32A ch4 Timer register C0 match trigger (T32A04TRGOUTCMPC0) 001: T32A ch4 Timer register C1 match trigger (T32A04TRGOUTCMPC1) 010: T32A ch4 Timer C overflow trigger (T32A04TRGOUTOFC) 011: T32A ch4 Timer C underflow trigger (T32A04TRGOUTUFC) 100: Reserved 101: Reserved 110: Reserved 111: Reserved
27	-	0	R	Read as "0"
26	UPDN3	0	R/W	Selection of edge detection conditions 0: Rising edge detection 1: falling edge detection
25	OUTSEL3	0	R/W	Selection of a trigger output 0: Edge detection is disabled 1: Edge detection is enabled
24	EN3	0	R/W	Setup of trigger output control 0: Disable 1: Enable
23	-	0	R	Read as "0"
22:20	INSEL2[2:0] (INSEL66[2:0])	000	R/W	Selection of an input trigger (T32A ch5 Timer B) 000: T32A ch5 Timer register A0 match trigger (T32A05TRGOUTCMPA0) 001: T32A ch5 Timer register A1 match trigger (T32A05TRGOUTCMPA1) 010: T32A ch5 Timer A overflow trigger (T32A05TRGOUTOFA) 011: T32A ch5 Timer A underflow trigger (T32A05TRGOUTUFA) 100: Reserved 101: Reserved 110: Reserved 111: Reserved
19	-	0	R	Read as "0"
18	UPDN2	0	R/W	Selection of edge detection conditions 0: Rising edge detection 1: falling edge detection
17	OUTSEL2	0	R/W	Selection of a trigger output 0: Edge detection is disabled 1: Edge detection is enabled
16	EN2	0	R/W	Setup of trigger output control 0: Disable 1: Enable

Bit	Bit Symbol	After Reset	Type	Function
15	-	0	R	Read as "0"
14:12	INSEL1[2:0] (INSEL65[2:0])	000	R/W	Selection of an input trigger (T32A ch5 Timer A) 000: PB1 pin (TRGIN0) 001: PA3 pin (TRGIN1) 010: PN3 pin (TRGIN2) 011: UART ch5 Transmission completion trigger (UART5TXTRG) 100: UART ch5 Reception completion trigger (UART5RXTRG) 101: TSPI ch3 transmit complete trigger (TSPI3TXEND) 110: TSPI ch3 receive complete trigger (TSPI3RXEND) 111: A-ENC32 ch0 Dividing pulse signal (ENC0TIMPLS) When <INSEL1[2:0]> is set to "000"(PB1 pin), "001"(PA3 pin) or "010"(PN3 pin), set <OUTSEL1> to "1"..
11	-	0	R	Read as "0"
10	UPDN1	0	R/W	Selection of edge detection conditions 0: Rising edge detection 1: falling edge detection
9	OUTSEL1	0	R/W	Selection of a trigger output 0: Edge detection is disabled 1: Edge detection is enabled
8	EN1	0	R/W	Setup of trigger output control 0: Disable 1: Enable
7	-	0	R	Read as "0"
6:4	INSEL0[2:0] (INSEL64[2:0])	000	R/W	Selection of an input trigger (T32A ch4 Timer C) 000: T32A ch3 Timer register C0 match trigger (T32A03TRGOUTCMPC0) 001: T32A ch3 Timer register C1 match trigger (T32A03TRGOUTCMPC1) 010: T32A ch3 Timer C overflow trigger (T32A03TRGOUTOFC) 011: T32A ch3 Timer C underflow trigger (T32A03TRGOUTUFC) 100: Reserved 101: Reserved 110: Reserved 111: Reserved
3	-	0	R	Read as "0"
2	UPDN0	0	R/W	Selection of edge detection conditions 0: Rising edge detection 1: falling edge detection
1	OUTSEL0	0	R/W	Selection of a trigger output 0: Edge detection is disabled 1: Edge detection is enabled
0	EN0	0	R/W	Setup of trigger output control 0: Disable 1: Enable

2.2.4.18. [TSEL1CR1] (Control Register 1)

Bit	Bit Symbol	After Reset	Type	Function
31	-	0	R	Read as "0"
30:28	INSEL7[2:0] (INSEL71[2:0])	000	R/W	Selection of an input trigger (T32A ch7 Timer A) 000: PB1 pin (TRGIN0) 001: PA3 pin (TRGIN1) 010: PN3 pin (TRGIN2) 011: ADC unit A General purpose trigger interrupt (INTADATRG) 100: ADC unit A Single conversion interrupt (INTADASG) 101: ADC unit A Continuous conversion interrupt (INTADACNT) 110: ADC unit A Monitor function interrupt 0 (INTADACP0) 111: ADC unit A Monitor function interrupt 1 (INTADACP1) When <INSEL7[2:0]> is set to "000"(PB1 pin), "001"(PA3 pin) or "010"(PN3 pin), set <OUTSEL7> to "1".
27	-	0	R	Read as "0"
26	UPDN7	0	R/W	Selection of edge detection conditions 0: Rising edge detection 1: falling edge detection
25	OUTSEL7	0	R/W	Selection of a trigger output 0: Edge detection is disabled 1: Edge detection is enabled
24	EN7	0	R/W	Setup of trigger output control 0: Disable 1: Enable
23	-	0	R	Read as "0"
22:20	INSEL6[2:0] (INSEL70[2:0])	000	R/W	Selection of an input trigger (T32A ch6 Timer C) 000: T32A ch5 Timer register C0 match trigger (T32A05TRGOUTCMPC0) 001: T32A ch5 Timer register C1 match trigger (T32A05TRGOUTCMPC1) 010: T32A ch5 Timer C overflow trigger (T32A05TRGOUTOFC) 011: T32A ch5 Timer C underflow trigger (T32A05TRGOUTUFC) 100: Reserved 101: Reserved 110: Reserved 111: Reserved
19	-	0	R	Read as "0"
18	UPDN6	0	R/W	Selection of edge detection conditions 0: Rising edge detection 1: falling edge detection
17	OUTSEL6	0	R/W	Selection of a trigger output 0: Edge detection is disabled 1: Edge detection is enabled
16	EN6	0	R/W	Setup of trigger output control 0: Disable 1: Enable

Bit	Bit Symbol	After Reset	Type	Function
15	-	0	R	Read as "0"
14:12	INSEL5 [2:0] (INSEL69[2:0])	000	R/W	Selection of an input trigger (T32A ch6 Timer B) 000: T32A ch6 Timer register A0 match trigger (T32A06TRGOUTCMPA0) 001: T32A ch6 Timer register A1 match trigger (T32A06TRGOUTCMPA1) 010: T32A ch6 Timer A overflow trigger (T32A06TRGOUTOFA) 011: T32A ch6 Timer A underflow trigger (T32A06TRGOUTUFA) 100: Reserved 101: Reserved 110: Reserved 111: Reserved
11	-	0	R	Read as "0"
10	UPDN5	0	R/W	Selection of edge detection conditions 0: Rising edge detection 1: falling edge detection
9	OUTSEL5	0	R/W	Selection of a trigger output 0: Edge detection is disabled 1: Edge detection is enabled
8	EN5	0	R/W	Setup of trigger output control 0: Disable 1: Enable
7	-	0	R	Read as "0"
6:4	INSEL4[2:0] (INSEL68[2:0])	000	R/W	Selection of an input trigger (T32A ch6 Timer A) 000: PB1 pin (TRGIN0) 001: PA3 pin (TRGIN1) 010: PN3 pin (TRGIN2) 011: TSPI ch4 transmit complete trigger (TSPI4TXEND) (Note) 100: TSPI ch4 receive complete trigger (TSPT4RXEND) (Note) 101: ELOSC Low speed clock (fs) 110: Reserved 111: Reserved When <INSEL4[2:0]> is set to "000"(PB1 pin), "001"(PA3 pin) or "010"(PN3 pin), set <OUTSEL4> to "1".
3	-	0	R	Read as "0"
2	UPDN4	0	R/W	Selection of edge detection conditions 0: Rising edge detection 1: falling edge detection
1	OUTSEL4	0	R/W	Selection of a trigger output 0: Edge detection is disabled 1: Edge detection is enabled
0	EN4	0	R/W	Setup of trigger output control 0: Disable 1: Enable

Note: There is no TSPI ch4 in M3HN, M3HM, and M3HL.

2.2.4.19. [TSEL1CR2] (Control Register 2)

Bit	Bit Symbol	After Reset	Type	Function
31	-	0	R	Read as "0"
30:28	INSEL11[2:0] (INSEL75[2:0])	000	R/W	Selection of an input trigger (UART ch7) (Note) 000: PB1 pin (TRGIN0) 001: PA3 pin (TRGIN1) 010: PN3 pin (TRGIN2) 011: T32A ch6 Timer register A1 match trigger (T32A06TRGOUTCMPA1) 100: T32A ch6 Timer register B1 match trigger (T32A06TRGOUTCMPB1) 101: T32A ch6 Timer register C1 match trigger (T32A06TRGOUTCMPC1) 110: reserved 111: reserved When <INSEL11[2:0]> is set to "000"(PB1 pin), "001"(PA3 pin) or "010"(PN3 pin), set <OUTSEL11> to "1".
27	-	0	R	Read as "0"
26	UPDN11	0	R/W	Selection of edge detection conditions 0: Rising edge detection 1: falling edge detection
25	OUTSEL11	0	R/W	Selection of a trigger output 0: Edge detection is disabled 1: Edge detection is enabled
24	EN11	0	R/W	Setup of trigger output control 0: Disable 1: Enable
23	-	0	R	Read as "0"
22:20	INSEL10[2:0] (INSEL74[2:0])	000	R/W	Selection of an input trigger (UART ch6) 000: PB1 pin (TRGIN0) 001: PA3 pin (TRGIN1) 010: PN3 pin (TRGIN2) 011: T32A ch6 Timer register A1 match trigger (T32A06TRGOUTCMPA1) 100: T32A ch6 Timer register B1 match trigger (T32A06TRGOUTCMPB1) 101: T32A ch6 Timer register C1 match trigger (T32A06TRGOUTCMPC1) 110: reserved 111: reserved When <INSEL10[2:0]> is set to "000"(PB1 pin), "001"(PA3 pin) or "010"(PN3 pin), set <OUTSEL10> to "1".
19	-	0	R	Read as "0"
18	UPDN10	0	R/W	Selection of edge detection conditions 0: Rising edge detection 1: falling edge detection
17	OUTSEL10	0	R/W	Selection of a trigger output 0: Edge detection is disabled 1: Edge detection is enabled
16	EN10	0	R/W	Setup of trigger output control 0: Disable 1: Enable

Bit	Bit Symbol	After Reset	Type	Function
15	-	0	R	Read as "0"
14:12	INSEL9[2:0] (INSEL73[2:0])	000	R/W	Selection of an input trigger (T32A ch7 Timer C) 000: T32A ch6 Timer register C0 match trigger (T32A06TRGOUTCMPC0) 001: T32A ch6 Timer register C1 match trigger (T32A06TRGOUTCMPC1) 010: T32A ch6 Timer C overflow trigger (T32A06TRGOUTOFC) 011: T32A ch6 Timer C underflow trigger (T32A06TRGOUTUFC) 100: Reserved 101: Reserved 110: Reserved 111: Reserved
11	-	0	R	Read as "0"
10	UPDN9	0	R/W	Selection of edge detection conditions 0: Rising edge detection 1: falling edge detection
9	OUTSEL9	0	R/W	Selection of a trigger output 0: Edge detection is disabled 1: Edge detection is enabled
8	EN9	0	R/W	Setup of trigger output control 0: Disable 1: Enable
7	-	0	R	Read as "0"
6:4	INSEL8[2:0] (INSEL72[2:0])	000	R/W	Selection of an input trigger (T32A ch7 Timer B) 000: T32A ch7 Timer register A0 match trigger (T32A07TRGOUTCMPA0) 001: T32A ch7 Timer register A1 match trigger (T32A07TRGOUTCMPA1) 010: T32A ch7 Timer A overflow trigger (T32A07TRGOUTOFA) 011: T32A ch7 Timer A underflow trigger (T32A07TRGOUTUFA) 100: Reserved 101: Reserved 110: Reserved 111: Reserved
3	-	0	R	Read as "0"
2	UPDN8	0	R/W	Selection of edge detection conditions 0: Rising edge detection 1: falling edge detection
1	OUTSEL8	0	R/W	Selection of a trigger output 0: Edge detection is disabled 1: Edge detection is enabled
0	EN8	0	R/W	Setup of trigger output control 0: Disable 1: Enable

Note: There is no UART ch7 in M3HM and M3HL.

2.2.4.20. [TSEL1CR3] (Control Register 3)

Bit	Bit Symbol	After Reset	Type	Function
31	-	0	R	Read as "0".
30:28	INSEL15[2:0] (INSEL79[2:0])	000	R/W	Selection of an input trigger (T32A ch3 Timer A) 000: INSEL59 001: T32A ch3 Timer register B0 match trigger (T32A03TRGOUTCMPB0) 010: T32A ch3 Timer register B1 match trigger (T32A03TRGOUTCMPB1) 011: T32A ch3 Timer B overflow trigger (T32A03TRGOUTOFB) 100: T32A ch3 Timer B underflow trigger (T32A03TRGOUTUFB) 101: reserved 110: reserved 111: reserved
27	-	0	R	Read as "0"
26	UPDN15	0	R/W	Selection of edge detection conditions 0: Rising edge detection 1: falling edge detection
25	OUTSEL15	0	R/W	Selection of a trigger output 0: Edge detection is disabled 1: Edge detection is enabled
24	EN15	0	R/W	Setup of trigger output control 0: Disable 1: Enable
23	-	0	R	Read as "0".
22:20	INSEL14[2:0] (INSEL78[2:0])	000	R/W	Selection of an input trigger (T32A ch2 Timer A) 000: INSEL56 001: T32A ch2 Timer register B0 match trigger (T32A02TRGOUTCMPB0) 010: T32A ch2 Timer register B1 match trigger (T32A02TRGOUTCMPB1) 011: T32A ch2 Timer B overflow trigger (T32A02TRGOUTOFB) 100: T32A ch2 Timer B underflow (T32A02TRGOUTUFB) 101: reserved 110: reserved 111: reserved
19	-	0	R	Read as "0".
18	UPDN14	0	R/W	Selection of edge detection conditions 0: Rising edge detection 1: falling edge detection
17	OUTSEL14	0	R/W	Selection of a trigger output 0: Edge detection is disabled 1: Edge detection is enabled
16	EN14	0	R/W	Setup of trigger output control 0: Disable 1: Enable

Bit	Bit Symbol	After Reset	Type	Function
15	-	0	R	Read as "0".
14:12	INSEL13[2:0] (INSEL77[2:0])	000	R/W	Selection of an input trigger (T32A ch1 Timer A) 000: INSEL53 001: T32A ch1 Timer register B0 match trigger (T32A01TRGOUTCMPB0) 010: T32A ch1 Timer register B1 match trigger (T32A01TRGOUTCMPB1) 011: T32A ch1 Timer B overflow trigger (T32A01TRGOUTOFB) 100: T32A ch1 Timer B underflow trigger (T32A01TRGOUTUFB) 101: reserved 110: reserved 111: reserved
11	-	0	R	Read as "0"
10	UPDN13	0	R/W	Selection of edge detection conditions 0: Rising edge detection 1: falling edge detection
9	OUTSEL13	0	R/W	Selection of a trigger output 0: Edge detection is disabled 1: Edge detection is enabled
8	EN13	0	R/W	Setup of trigger output control 0: Disable 1: Enable
7	-	0	R	Read as "0".
6:4	INSEL12[2:0] (INSEL76[2:0])	000	R/W	Selection of an input trigger (T32A ch0 Timer A) 000: INSEL50 001: T32A ch0 Timer register B0 match trigger (T32A00TRGOUTCMPB0) 010: T32A ch0 Timer register B1 match trigger (T32A00TRGOUTCMPB1) 011: T32A ch0 Timer B overflow trigger (T32A00TRGOUTOFB) 100: T32A ch0 Timer B underflow trigger (T32A00TRGOUTUFB) 101: reserved 110: reserved 111: reserved
3	-	0	R	Read as "0".
2	UPDN12	0	R/W	Selection of edge detection conditions 0: Rising edge detection 1: falling edge detection
1	OUTSEL12	0	R/W	Selection of a trigger output 0: Edge detection is disabled 1: Edge detection is enabled
0	EN12	0	R/W	Setup of trigger output control 0: Disable 1: Enable

2.2.4.21. [TSEL1CR4] (Control register 4)

Bit	Bit Symbol	After Reset	Type	Function
31	-	0	R	Read as "0"
30:28	INSEL19[2:0] (INSEL83[2:0])	000	R/W	Selection of an input trigger (T32A ch7 Timer A) 000: INSEL71 001: T32A ch7 Timer register B0 match trigger (T32A07TRGOUTCMPB0) 010: T32A ch7 Timer register B1 match trigger (T32A07TRGOUTCMPB1) 011: T32A ch7 Timer B overflow trigger (T32A07TRGOUTOFB) 100: T32A ch7 Timer B underflow trigger (T32A07TRGOUTUFB) 101: UART ch7 transmission completion trigger (UART7TXTRG)(Note) 110: UART ch7 reception completion trigger (UART7RXTRG)(Note) 111: reserved
27	-	0	R	Read as "0"
26	UPDN19	0	R/W	Selection of edge detection conditions 0: Rising edge detection 1: falling edge detection
25	OUTSEL19	0	R/W	Selection of a trigger output 0: Edge detection is disabled 1: Edge detection is enabled
24	EN19	0	R/W	Setup of trigger output control 0: Disable 1: Enable
23	-	0	R	Read as "0"
22:20	INSEL18[2:0] (INSEL82[2:0])	000	R/W	Selection of an input trigger (T32A ch6 Timer A) 000: INSEL68 001: T32A ch6 Timer register B0 match trigger (T32A06TRGOUTCMPB0) 010: T32A ch6 Timer register B1 match trigger (T32A06TRGOUTCMPB1) 011: T32A ch6 Timer B overflow trigger (T32A06TRGOUTOFB) 100: T32A ch6 Timer B underflow trigger (T32A06TRGOUTUFB) 101: UART ch6 transmission completion trigger (UART6TXTRG) 110: UART ch6 reception completion trigger (UART6RXTRG) 111: reserved
19	-	0	R	Read as "0"
18	UPDN18	0	R/W	Selection of edge detection conditions 0: Rising edge detection 1: falling edge detection
17	OUTSEL18	0	R/W	Selection of a trigger output 0: Edge detection is disabled 1: Edge detection is enabled
16	EN18	0	R/W	Setup of trigger output control 0: Disable 1: Enable

Bit	Bit Symbol	After Reset	Type	Function
15	-	0	R	Read as "0"
14:12	INSEL17[2:0] (INSEL81[2:0])	000	R/W	Selection of an input trigger (T32A ch5 Timer A) 000: INSEL65 001: T32A ch5 Timer register B0 match trigger (T32A05TRGOUTCMPB0) 010: T32A ch5 Timer register B1 match trigger (T32A05TRGOUTCMPB1) 011: T32A ch5 Timer B overflow trigger (T32A05TRGOUTOFB) 100: T32A ch5 Timer B underflow trigger (T32A05TRGOUTUFB) 101: reserved 110: reserved 111: reserved
11	-	0	R	Read as "0"
10	UPDN17	0	R/W	Selection of edge detection conditions 0: Rising edge detection 1: falling edge detection
9	OUTSEL17	0	R/W	Selection of a trigger output 0: Edge detection is disabled 1: Edge detection is enabled
8	EN17	0	R/W	Setup of trigger output control 0: Disable 1: Enable
7	-	0	R	Read as "0"
6:4	INSEL16[2:0] (INSEL80[2:0])	000	R/W	Selection of an input trigger (T32A ch4 Timer A) 000: INSEL62 001: T32A ch4 Timer register B0 match trigger (T32A04TRGOUTCMPB0) 010: T32A ch4 Timer register B1 match trigger (T32A04TRGOUTCMPB1) 011: T32A ch4 Timer B overflow trigger (T32A04TRGOUTOFB) 100: T32A ch4 Timer B underflow trigger (T32A04TRGOUTUFB) 101: reserved 110: reserved 111: reserved
3	-	0	R	Read as "0"
2	UPDN16	0	R/W	Selection of edge detection conditions 0: Rising edge detection 1: falling edge detection
1	OUTSEL16	0	R/W	Selection of a trigger output 0: Edge detection is disabled 1: Edge detection is enabled
0	EN16	0	R/W	Setup of trigger output control 0: Disable 1: Enable

Note: There is no UART ch7 in M3HM and M3HL.

2.3. Clock Selective Watchdog Timer (SIWDT)

2.3.1. Built-in channel

The built-in channel for each product is shown in the following table.

Table 2.17 SIWDT Built-in channel

Product	SIWDT Built-in channel (✓: Available, -: N/A)
	ch0
M3HQ	✓
M3HP	✓
M3HN	✓
M3HM	✓
M3HL	✓

2.3.2. Count clock

The clock selective watchdog timer can select the clock to count. The clock which can be selected as the following table is shown.

Table 2.18 SIWDT Count clock

Clock	Signal name	Selection
System clock	f _{sys}	It selects by the [SIWD0MOD]<WDCLS> register.
Internal High Speed Oscillator 1 Clock	f _{IHOSC1}	
Internal High Speed Oscillator 2 Clock	f _{IHOSC2}	

2.3.3. Control Output

When the Internal High Speed Oscillator2 (f_{IHOSC2}) is selected, it is possible to forbid rewriting of the Internal High Speed Oscillator 2.

Table 2.19 SIWDT Control Output

Control Output	Signal name	Remarks
The protection signal of an Internal High Speed Oscillator2 oscillation control bit ([CGOSCCR]<IHOSC2EN>).	OSCPRO	It sets up by the [SIWD0OSCCR]<OSCPRO> register.

2.4. Oscillation Frequency Detector (OFD)

2.4.1. Built-in List

The following table shows the built-in list for each product.

Table 2.20 OFD Built-in List

Product	Built-in OFD (✓: Available, -: N/A)
M3HQ	✓
M3HP	✓
M3HN	✓
M3HM	✓
M3HL	✓

2.4.2. Reference clock

The frequency detection circuit operates with the clock in the following table as the reference clock.

Table 2.21 OFD Reference clock

Reference clock	Signal name	divide value
Internal High Speed Oscillator 2	f _{IHOSC2}	256

2.4.3. Detection object clock

An Oscillation Frequency Detector selects a clock to monitor from the detection object clock of the following table.

Table 2.22 OFD Detection object clock

Detection object clock		Signal name
Input Signal	External High Speed Oscillator Clock	f _{EHOSC}
	It is the clock selected by [CGOSCCR]<OSCSEL> and [CGPLLOSEL]<PLL0SEL> of CG (Clock control part).	fc

2.5. Debug interface

2.5.1. Debugging interface terminal list of each product

This has the JTAG (TMS, TCK, TDI, TRST_N) and Serial Wire (SWDIO, SWCLK, SWV).

Table 2.23 Debugging interface terminal list

Debugging pin (Signal name)	Port	Built-in pins (✓: Available, -: N/A)				
		M3HQ	M3HP	M3HN	M3HM	M3HL
SWDIO	PL4	✓	✓	✓	✓	✓
TMS						
SWCLK	PL3	✓	✓	✓	✓	✓
TCK						
SWV	PL2	✓	✓	✓	✓	✓
TDO						
TDI	PL1	✓	✓	✓	✓	✓
TRST_N	PL0	✓	✓	✓	✓	✓
TRACECLK	PM0	✓	✓	✓	✓	-
TRACEDATA0	PM1	✓	✓	✓	✓	-
TRACEDATA1	PM2	✓	✓	✓	✓	-
TRACEDATA2	PM3	✓	✓	✓	-	-
TRACEDATA3	PM4	✓	✓	✓	-	-

2.5.2. Divided ratio for Trace clock

Table 2.24 Divided ratio for Trace Clock (TRACECLK)

Source Clock	Divided ratio	Output
fsys	1/4	TRACECLK

2.6. Flash Memory

2.6.1. Clock for Programming/Erasing

As for flash memory, the clock of the following table is used for programming/erasing of the code flash or the data flash.

Table 2.25 Clock for Programming/Erasing

Clock for Programming/Erasing
f _{IHOSC1}

2.6.2. The code flash block configuration of each product.

The code flash memory differs in the block configuration of the memory with the product, as shown in the following table.

Table 2.26 The code flash of each product

Area	Block name		TMPM3HQF10BFG TMPM3HPF10BFG TMPM3HPF10BDFG TMPM3HNF10BFG TMPM3HNF10BDFG TMPM3HMF10BFG TMPM3HLF10BUG	TMPM3HNFDBFG	Block Size (KB)
0	Block0	PG0	✓	✓	4
		PG1	✓	✓	4
		PG2	✓	✓	4
		PG3	✓	✓	4
		PG4	✓	✓	4
		PG5	✓	✓	4
		PG6	✓	✓	4
		PG7	✓	✓	4
	Block1	✓	✓	32	
	Block2	✓	✓	32	
	Block3	✓	✓	32	
	Block4	✓	✓	32	
	Block5	✓	✓	32	
	Block6	✓	✓	32	
	Block7	✓	✓	32	
Block8	✓	✓	32		
Block9	✓	✓	32		
Block10	✓	✓	32		
Block11	✓	✓	32		
Block12	✓	✓	32		
Block13	✓	✓	32		
Block14	✓	✓	32		

	Block15	✓	✓	32
1	Block16	✓	-	32
	Block17	✓	-	32
	Block18	✓	-	32
	Block19	✓	-	32
	Block20	✓	-	32
	Block21	✓	-	32
	Block22	✓	-	32
	Block23	✓	-	32
	Block24	✓	-	32
	Block25	✓	-	32
	Block26	✓	-	32
	Block27	✓	-	32
	Block28	✓	-	32
	Block29	✓	-	32
	Block30	✓	-	32
	Block31	✓	-	32

Note: ✓: Available, -: N/A

2.6.3. The data flash block configuration of each product.

Block configuration of data flash memory is shown in the following table.

Table 2.27 The data flash of each product

Area	Block name	TMPM3HQF10BFG	Block Size (KB)
		TMPM3HPF10BFG	
4	Block0	✓	4
	Block1	✓	4
	Block2	✓	4
	Block3	✓	4
	Block4	✓	4
	Block5	✓	4
	Block6	✓	4
	Block7	✓	4

Note: ✓: Available, -: N/A

2.6.4. Access Control register

Initial value of Access Control register $[FCACCR]<FDLC[2:0]>$ and $<FCLC[2:0]>$ is as following.

Table 2.28 Access Control register

Bit	Bit Symbol	After Reset	Function
10:8	FDLC[2:0]	011	Reading clock control for Data Flash Memory 100: fsys > 80MHz 011: fsys ≤ 80MHz
2:0	FCLC[2:0]	011	Reading clock control for Code Flash Memory 100: fsys > 80MHz 011: fsys ≤ 80MHz

2.6.5. Macro Code at ID read

Macro Code of this product is as following.

Table 2.29 Macro Code at ID read

Code	ID[15:0]
Macro Code (Code Flash)	0x0402
Macro Code (Data Flash)	0x0404

2.6.6. Single boot use resource

The peripheral function of the following table is used in single boot.

Table 2.30 Single boot use resource

Peripheral function	Channel	Pin name
BOOT	-	PB0 (BOOT_N)
UART	ch0	PA1/PA2 (UT0TXDA/UT0RXD) or, PM1/PM2 (UT0TXDA/UT0RXD) (Note)
T32A	ch0	-

Note: At the time of single boot start, the selection of PA1/PA2 or PM1/PM2 is distinguished automatically by the state of the terminal. During the automatic distinction, internal pull-up of PA2/UT0RXD and PM2/UT0RXD enabled, and the "High" level is outputted. Please keep the "High" level (open or "High" level input) of UT0RXD which is not used at this time. As for UT0RXD which is not used after automatic distinction finishes, "Hi-z" is outputted.

The range of the RAM address transmitted by the RAM loader command should use the following table.

Table 2.31 The end address in which RAM transmission is possible

Product name	The end address in which RAM transmission is possible
TMPM3HQF10BFG TMPM3HPF10BFG TMPM3HPF10BDFG	0x20000400 to 0x2001FFFF

TMPM3HNF10BFG TMPM3HNF10BDFG TMPM3HMF10BFG TMPM3HLF10BUG TMPM3HNFDBFG	
---	--

2.7. DMA Controller (DMAC)

2.7.1. Built-in unit

The built-in unit for each product is shown in the following table.

Table 2.32 DMAC Built-in unit

Product	DMAC Built-in unit (✓: Available, -: N/A)	
	unit A	unit B
M3HQ	✓	✓
M3HP	✓	✓
M3HN	✓	✓
M3HM	✓	✓
M3HL	✓	✓

2.7.2. DMA request list

A DMA request list is shown in the following table.

The channel which has a register name in the trigger selector column of a table should select the request used by a trigger selector. "-" in a table does not have an applicable function.

Table 2.33 DMA unit A Request list (1/4)

ch	Single transmission		Burst transmission		
		Signal name	Trigger selector		Signal name
0	TSPI ch0 Receive DMA request	TSPI0RX_DMA	-	TSPI ch0 Receive DMA request	TSPI0RX_DMA
1	TSPI ch0 Transmit DMA request	TSPI0TX_DMA	-	TSPI ch0 Transmit DMA request	TSPI0TX_DMA
2	TSPI ch1 Receive DMA request (Note)	TSPI1RX_DMA	-	TSPI ch1 Receive DMA request (Note)	TSPI1RX_DMA
3	TSPI ch1 Transmit DMA request (Note)	TSPI1TX_DMA	-	TSPI ch1 Transmit DMA request (Note)	TSPI1TX_DMA
4	-	-	-	EI2C/I2C ch0 Receiving DMA request	I2C0ARXDMAREQ I2C0RXDMAREQ
5	-	-	-	EI2C/I2C ch0 Transmitting DMA request	I2C0ATXDMAREQ I2C0TXDMAREQ
6	UART ch0 Reception DMA request	UART0RX_DMAREQ	-	UART ch0 Reception DMA request	UART0RX_DMAREQ
7	UART ch0 Transmission DMA request	UART0TX_DMAREQ	-	UART ch0 Transmission DMA request	UART0TX_DMAREQ
8	UART ch1 Reception DMA request	UART1RX_DMAREQ	-	UART ch1 Reception DMA request	UART1RX_DMAREQ
9	UART ch1 Transmission DMA request	UART1TX_DMAREQ	-	UART ch1 Transmission DMA request	UART1TX_DMAREQ
10	UART ch2 Reception DMA request	UART2RX_DMAREQ	-	UART ch2 Reception DMA request	UART2RX_DMAREQ
11	UART ch2 Transmission DMA request	UART2TX_DMAREQ	-	UART ch2 Transmission DMA request	UART2TX_DMAREQ
12	UART ch3 Reception DMA request	UART3RX_DMAREQ	-	UART ch3 Reception DMA request	UART3RX_DMAREQ

Note: There is no TSPI ch1 in M3HL.

Table 2.34 DMA unit A Request list (2/4)

ch	Single transmission		Burst transmission		
		Signal name	Trigger selector		Signal name
13	UART ch3 Transmission DMA request	UART3TX_DMAREQ	-	UART ch3 Transmission DMA request	UART3TX_DMAREQ
14	-	-	-	A-PMD ch0 PWM interrupt	INTPWM0
15	-	-	[TSEL0CR0] <INSEL0[2:0]> (Note)	T32A ch0 DMA request at match A1 register	T32A00DMAREQCPA1
				T32A ch0 DMA request at match C1 register	T32A00DMAREQCMPC1
				T32A ch1 DMA request at match A1 register	T32A01DMAREQCPA1
				T32A ch1 DMA request at match C1 register	T32A01DMAREQCMPC1
16	-	-	[TSEL0CR0] <INSEL1[2:0]> (Note)	T32A ch2 DMA request at match A1 register	T32A02DMAREQCPA1
				T32A ch2 DMA request at match C1 register	T32A02DMAREQCMPC1
				T32A ch3 DMA request at match A1 register	T32A03DMAREQCPA1
				T32A ch3 DMA request at match C1 register	T32A03DMAREQCMPC1
17	-	-	[TSEL0CR0] <INSEL2[2:0]> (Note)	T32A ch0 DMA request at match B1 register	T32A00DMAREQCMPB1
				T32A ch1 DMA request at match B1 register	T32A01DMAREQCMPB1
18	-	-	[TSEL0CR0] <INSEL3[2:0]> (Note)	T32A ch2 DMA request at match B1 register	T32A02DMAREQCMPB1
				T32A ch3 DMA request at match B1 register	T32A03DMAREQCMPB1
19	-	-	[TSEL0CR1] <INSEL4[2:0]> (Note)	T32A ch0 DMA request at capture A0 register	T32A00DMAREQCAPA0
				T32A ch0 DMA request at capture A1 register	T32A00DMAREQCAPA1
				T32A ch1 DMA request at capture A0 register	T32A01DMAREQCAPA0
				T32A ch1 DMA request at capture A1 register	T32A01DMAREQCAPA1
				T32A ch0 DMA request at capture C0 register	T32A00DMAREQCAPC0
				T32A ch0 DMA request at capture C1 register	T32A00DMAREQCAPC1
				T32A ch1 DMA request at capture C0 register	T32A01DMAREQCAPC0
				T32A ch1 DMA request at capture C1 register	T32A01DMAREQCAPC1

Note: Trigger selector selects the trigger source of a DMA request for ch15 to ch31. Please refer to "2.2. Trigger Selector (TRGSEL)" for the detailed connection.

Table 2.35 DMA unit A Request list (3/4)

ch	Single transmission		Burst transmission		
		Signal name	Trigger selector	Signal name	
20	-	-	[TSEL0CR1] <INSEL5[2:0]> (Note)	T32A ch2 DMA request at capture A0 register	T32A02DMAREQCAPA0
				T32A ch2 DMA request at capture A1 register	T32A02DMAREQCAPA1
				T32A ch3 DMA request at capture A0 register	T32A03DMAREQCAPA0
				T32A ch3 DMA request at capture A1 register	T32A03DMAREQCAPA1
				T32A ch2 DMA request at capture C0 register	T32A02DMAREQCAPC0
				T32A ch2 DMA request at capture C1 register	T32A02DMAREQCAPC1
				T32A ch3 DMA request at capture C0 register	T32A03DMAREQCAPC0
				T32A ch3 DMA request at capture C1 register	T32A03DMAREQCAPC1
21	-	-	[TSEL0CR1] <INSEL6[2:0]> (Note)	T32A ch0 DMA request at capture B0 register	T32A00DMAREQCAPB0
				T32A ch0 DMA request at capture B1 register	T32A00DMAREQCAPB1
				T32A ch1 DMA request at capture B0 register	T32A01DMAREQCAPB0
				T32A ch1 DMA request at capture B1 register	T32A01DMAREQCAPB1
22	-	-	[TSEL0CR1] <INSEL7[2:0]> (Note)	T32A ch2 DMA request at capture B0 register	T32A02DMAREQCAPB0
				T32A ch2 DMA request at capture B1 register	T32A02DMAREQCAPB1
				T32A ch3 DMA request at capture B0 register	T32A03DMAREQCAPB0
				T32A ch3 DMA request at capture B1 register	T32A03DMAREQCAPB1
23	-	-	[TSEL0CR2] <INSEL8[2:0]> (Note)	DMAC A ch0 transmission end interrupt	INTDMAATC0
				DMAC A ch1 transmission end interrupt	INTDMAATC1
				DMAC A ch6 transmission end interrupt	INTDMAATC6
				DMAC A ch7 transmission end interrupt	INTDMAATC7
24	-	-	[TSEL0CR2] <INSEL9[2:0]> (Note)	DMAC A ch2 transmission end interrupt	INTDMAATC2
				DMAC A ch3 transmission end interrupt	INTDMAATC3
				DMAC A ch8 transmission end interrupt	INTDMAATC8
				DMAC A ch9 transmission end interrupt	INTDMAATC9

Note: Trigger selector selects the trigger source of a DMA request for ch15 to ch31. Please refer to "2.2. Trigger Selector (TRGSEL)" for the detailed connection.

Table 2.36 DMA unit A Request list (4/4)

ch	Single transmission		Burst transmission		
		Signal name	Trigger selector	Signal name	
25	-	-	[TSEL0CR2] <INSEL10[2:0]> (Note)	DMAC A ch4 transmission end interrupt	INTDMAATC4
				DMAC A ch5 transmission end interrupt	INTDMAATC5
				DMAC A ch10 transmission end interrupt	INTDMAATC10
				DMAC A ch11 transmission end interrupt	INTDMAATC11
26	-	-	[TSEL0CR2] <INSEL11[2:0]> (Note)	DMAC A ch12 transmission end interrupt	INTDMAATC12
				DMAC A ch13 transmission end interrupt	INTDMAATC13
				DMAC A ch14 transmission end interrupt	INTDMAATC14
27	-	-	[TSEL0CR3] <INSEL12[2:0]> (Note)	DMAC A ch15 transmission end interrupt	INTDMAATC15
				DMAC A ch19 transmission end interrupt	INTDMAATC19
28	-	-	[TSEL0CR3] <INSEL13[2:0]> (Note)	DMAC A ch16 transmission end interrupt	INTDMAATC16
				DMAC A ch20 transmission end interrupt	INTDMAATC20
29	-	-	[TSEL0CR3] <INSEL14[2:0]> (Note)	DMAC A ch17 transmission end interrupt	INTDMAATC17
				DMAC A ch21 transmission end interrupt	INTDMAATC21
30	-	-	[TSEL0CR3] <INSEL15[2:0]> (Note)	DMAC A ch18 transmission end interrupt	INTDMAATC18
				DMAC A ch22 transmission end interrupt	INTDMAATC22
31	-	-	[TSEL0CR4] <INSEL16[2:0]> (Note)	PB1 pin	TRGIN0
				PA3 pin	TRGIN1
				PN3 pin	TRGIN2

Note: Trigger selector selects the trigger source of a DMA request for ch15 to ch31. Please refer to "2.2. Trigger Selector (TRGSEL)" for the detailed connection.

Table 2.37 DMA unit B Request list (1/4)

ch	Single transmission		Burst transmission		
		Signal name	Trigger selector		Signal name
0	TSPI ch2 Receive DMA request (Note2)	TSPI2RX_DMA	[TSEL0CR4] <INSEL17[2:0]> (Note1)	TSPI ch2 Receive DMA request (Note2)	TSPI2RX_DMA
				EI2C/I2C ch3 Receiving DMA request (Note3)	I2C3ARXDMAREQ/I2C3RXDMAREQ
1	TSPI ch2 Transmit DMA request (Note2)	TSPI2TX_DMA	[TSEL0CR4] <INSEL18[2:0]> (Note1)	TSPI ch2 Transmit DMA request (Note2)	TSPI2TX_DMA
				EI2C/I2C ch3 Transmitting DMA request (Note3)	I2C3ATXDMAREQ/I2C3TXDMAREQ
2	TSPI ch3 Receive DMA request (Note2)	TSPI3RX_DMA	-	TSPI ch3 Receive DMA request (Note2)	TSPI3RX_DMA
3	TSPI ch3 Transmit DMA request (Note2)	TSPI3TX_DMA	-	TSPI ch3 Transmit DMA request (Note2)	TSPI3TX_DMA
4	TSPI ch4 Receive DMA request (Note4)	TSPI4RX_DMA	-	TSPI ch4 Receive DMA request (Note4)	TSPI4RX_DMA
5	TSPI ch4 Transmit DMA request (Note4)	TSPI4TX_DMA	-	TSPI ch4 Transmit DMA request (Note4)	TSPI4TX_DMA
6	-	-	-	EI2C/I2C ch1 Receiving DMA request (Note2)	I2C1ARXDMAREQ I2C1RXDMAREQ
7	-	-	-	EI2C/I2C ch1 Transmitting DMA request (Note2)	I2C1ATXDMAREQ I2C1TXDMAREQ
8	-	-	-	EI2C/I2C ch2 Receiving DMA request	I2C2ARXDMAREQ I2C2RXDMAREQ
9	-	-	-	EI2C/I2C ch2 Transmitting DMA request	I2C2ATXDMAREQ I2C2TXDMAREQ
10	UART ch4 Reception DMA request	UART4RX_DMAREQ	-	UART ch4 Reception DMA request	UART4RX_DMAREQ
11	UART ch4 Transmission DMA request	UART4TX_DMAREQ	-	UART ch4 Transmission DMA request	UART4TX_DMAREQ
12	UART ch5 Reception DMA request	UART5RX_DMAREQ	-	UART ch5 Reception DMA request	UART5RX_DMAREQ
13	UART ch5 Transmission DMA request	UART5TX_DMAREQ	-	UART ch5 Transmission DMA request	UART5TX_DMAREQ
14	-	-	[TSEL0CR4] <INSEL19[2:0]> (Note1)	ADC unit A General purpose trigger DMA request	ADATRG_DMAREQ
				ADC unit A Single conversion DMA request	ADASGL_DMAREQ
				ADC unit A Continuous conversion DMA request	ADACNT_DMAREQ
15	-	-	[TSEL0CR5] <INSEL20[2:0]> (Note1)	T32A ch4 DMA request at match A1 register	T32A04DMAREQCMPA1
				T32A ch4 DMA request at match C1 register	T32A04DMAREQCMPC1
				T32A ch5 DMA request at match A1 register	T32A05DMAREQCMPA1
				T32A ch5 DMA request at match C1 register	T32A05DMAREQCMPC1
16	-	-	[TSEL0CR5] <INSEL21[2:0]> (Note1)	T32A ch6 DMA request at match A1 register	T32A06DMAREQCMPA1
				T32A ch6 DMA request at match C1 register	T32A06DMAREQCMPC1
				T32A ch7 DMA request at match A1 register	T32A07DMAREQCMPA1
				T32A ch7 DMA request at match C1 register	T32A07DMAREQCMPC1

Note1: Trigger selector selects the trigger source of a DMA request for ch0, ch1, ch14 to ch31. Please refer to "2.2. Trigger Selector (TRGSEL)" for the detailed connection.

Note2: There is no TSPI ch 2, ch 3 and EI2C/I2C ch 1 in M3HL.

Note3: There is no EI2C/I2C ch 3 in M3HN, M3HM, and M3HL.

Note4: There is no TSPI ch 4 in M3HN, M3HM, and M3HL.

Table 2.38 DMA unit B Request list (2/4)

ch	Single transmission		Burst transmission		
		Signal name	Trigger selector	Signal name	
17	UART ch6 reception DMA request	UART6RX_DMAREQ	[TSEL0CR5] <INSEL22[2:0]> (Note1)	T32A ch4 DMA request at match B1 register	T32A04DMAREQCMPB1
				T32A ch5 DMA request at match B1 register	T32A05DMAREQCMPB1
				UART ch6 reception DMA request	UART6RX_DMAREQ
18	UART ch6 transmission DMA request	UART6TX_DMAREQ	[TSEL0CR5] <INSEL23[2:0]> (Note1)	T32A ch6 DMA request at match B1 register	T32A06DMAREQCMPB1
				T32A ch7 DMA request at match B1 register	T32A07DMAREQCMPB1
				UART ch6 transmission DMA request	UART6TX_DMAREQ
19	-	-	[TSEL0CR6] <INSEL24[2:0]> (Note1)	T32A ch4 DMA request at capture A0 register	T32A04DMAREQCAPA0
				T32A ch4 DMA request at capture A1 register	T32A04DMAREQCAPA1
				T32A ch5 DMA request at capture A0 register	T32A05DMAREQCAPA0
				T32A ch5 DMA request at capture A1 register	T32A05DMAREQCAPA1
				T32A ch4 DMA request at capture C0 register	T32A04DMAREQCAPC0
				T32A ch4 DMA request at capture C1 register	T32A04DMAREQCAPC1
				T32A ch5 DMA request at capture C0 register	T32A05DMAREQCAPC0
				T32A ch5 DMA request at capture C1 register	T32A05DMAREQCAPC1
20	-	-	[TSEL0CR6] <INSEL25[2:0]> (Note1)	T32A ch6 DMA request at capture A0 register	T32A06DMAREQCAPA0
				T32A ch6 DMA request at capture A1 register	T32A06DMAREQCAPA1
				T32A ch7 DMA request at capture A0 register	T32A07DMAREQCAPA0
				T32A ch7 DMA request at capture A1 register	T32A07DMAREQCAPA1
				T32A ch6 DMA request at capture C0 register	T32A06DMAREQCAPC0
				T32A ch6 DMA request at capture C1 register	T32A06DMAREQCAPC1
				T32A ch7 DMA request at capture C0 register	T32A07DMAREQCAPC0
				T32A ch7 DMA request at capture C1 register	T32A07DMAREQCAPC1
21	UART ch7 reception DMA request (Note2)	UART7RX_DMAREQ	[TSEL0CR6] <INSEL26[2:0]> (Note1)	T32A ch4 DMA request at capture B0 register	T32A04DMAREQCAPB0
				T32A ch4 DMA request at capture B1 register	T32A04DMAREQCAPB1
				T32A ch5 DMA request at capture B0 register	T32A05DMAREQCAPB0
				T32A ch5 DMA request at capture B1 register	T32A05DMAREQCAPB1
				UART ch7 reception DMA request (Note2)	UART7RX_DMAREQ

Note1: Trigger selector selects the trigger source of a DMA request for ch0, ch1, ch14 to ch31. Please refer to "2.2. Trigger Selector (TRGSEL)" for the detailed connection.

Note2: There is no UART ch7 in M3HM, M3HL.

Table 2.39 DMA unit B Request list (3/4)

ch	Single transmission		Burst transmission		
		Signal name	Trigger selector	Signal name	
22	UART ch7 transmission DMA request (Note2)	UART7TX_DMAREQ	[TSEL0CR6] <INSEL27[2:0]> (Note1)	T32A ch6 DMA request at capture B0 register	T32A06DMAREQCAPB0
				T32A ch6 DMA request at capture B1 register	T32A06DMAREQCAPB1
				T32A ch7 DMA request at capture B0 register	T32A07DMAREQCAPB0
				T32A ch7 DMA request at capture B1 register	T32A07DMAREQCAPB1
				UART ch7 transmission DMA request (Note2)	UART7TX_DMAREQ
23	-	-	[TSEL0CR7] <INSEL28[2:0]> (Note1)	DMAC B ch0 transmission end interrupt	INTDMABTC0
				DMAC B ch1 transmission end interrupt	INTDMABTC1
				DMAC B ch6 transmission end interrupt	INTDMABTC6
				DMAC B ch7 transmission end interrupt	INTDMABTC7
24	-	-	[TSEL0CR7] <INSEL29[2:0]> (Note1)	DMAC B ch2 transmission end interrupt	INTDMABTC2
				DMAC B ch3 transmission end interrupt	INTDMABTC3
				DMAC B ch8 transmission end interrupt	INTDMABTC8
				DMAC B ch9 transmission end interrupt	INTDMABTC9
25	-	-	[TSEL0CR7] <INSEL30[2:0]> (Note1)	DMAC B ch4 transmission end interrupt	INTDMABTC4
				DMAC B ch5 transmission end interrupt	INTDMABTC5
				DMAC B ch10 transmission end interrupt	INTDMABTC10
				DMAC B ch11 transmission end interrupt	INTDMABTC11
26	-	-	[TSEL0CR7] <INSEL31[2:0]> (Note1)	DMAC B ch12 transmission end interrupt	INTDMABTC12
				DMAC B ch13 transmission end interrupt	INTDMABTC13
				DMAC B ch14 transmission end interrupt	INTDMABTC14
27	-	-	[TSEL0CR8] <INSEL32[2:0]> (Note1)	DMAC B ch15 transmission end interrupt	INTDMABTC15
				DMAC B ch19 transmission end interrupt	INTDMABTC19
28	-	-	[TSEL0CR8] <INSEL33[2:0]> (Note1)	DMAC B ch16 transmission end interrupt	INTDMABTC16
				DMAC B ch20 transmission end interrupt	INTDMABTC20

Note1: Trigger selector selects the trigger source of a DMA request for ch0, ch1, ch14 to ch31. Please refer to "2.2. Trigger Selector (TRGSEL)" for the detailed connection.

Note2: There is no UART ch7 in M3HM, M3HL.

Table 2.40 DMA unit B Request list (4/4)

ch	Single transmission		Burst transmission		
		Signal name	Trigger selector	Signal name	
29	-	-	[TSEL0CR8] <INSEL34[2:0]> (Note1)	DMAC B ch17 transmission end interrupt	INTDMABTC17
				DMAC B ch21 transmission end interrupt	INTDMABTC21
30	-	-	[TSEL0CR8] <INSEL35[2:0]> (Note1)	DMAC B ch18 transmission end interrupt	INTDMABTC18
				DMAC B ch22 transmission end interrupt	INTDMABTC22
31	-	-	[TSEL0CR9] <INSEL36[2:0]> (Note1)	PB1 pin	TRGIN0
				PA3 pin	TRGIN1
				PN3 pin	TRGIN2

Note1: Trigger selector selects the trigger source of a DMA request for ch0, ch1, ch14 to ch31. Please refer to "2.2. Trigger Selector (TRGSEL)" for the detailed connection.

2.8. Advanced Programmable Motor Control Circuit (A-PMD)

2.8.1. Built-in channel

The built-in channel for each product is shown in the following table.

Table 2.41 A-PMD Built-in channel

Product	A-PMD Built-in channel (✓: Available, -: N/A)
	ch0
M3HQ	✓
M3HP	✓
M3HN	✓
M3HM	✓
M3HL	✓

2.8.2. Functional pin and port

The functional terminal is assigned to the following ports.

Table 2.42 A-PMD Functional pin

ch	Functional pin		Signal name	Port	Product table (✓: Available, -: N/A)				
					M3HQ	M3HP	M3HN	M3HM	M3HL
A-PMD ch0	XO0	Output	XO0	PJ1	✓	✓	✓	✓	✓
	YO0	Output	YO0	PJ3	✓	✓	✓	✓	✓
	ZO0	Output	ZO0	PJ5	✓	✓	✓	✓	✓
	UO0	Output	UO0	PJ0	✓	✓	✓	✓	✓
	VO0	Output	VO0	PJ2	✓	✓	✓	✓	✓
	WO0	Output	WO0	PJ4	✓	✓	✓	✓	✓
	PMD0DBG	Output	PMD0DBG	PP6	✓	✓	✓	✓	-
	EMG0	Input	EMG0	PK0	✓	✓	✓	✓	✓
OVV0	Input	OVV0	PK1	✓	✓	✓	✓	✓	

2.8.3. DMA request

The advanced programmable motor control circuit has the DMA request shown in the following table.

Table 2.43 A-PMD DMA request

ch	Request	Signal name	Trigger selector	DMA request channel			
				ch	unit	Single transmission	Burst transmission
A-PMD ch0	A-PMD ch0 PWM interrupt	INTPWM0	-	14	A	-	✓

Note: ✓: Available, -: N/A

2.8.4. Other connections

The advanced programmable motor control circuit is connected with the peripheral function inside, as shown in the following table.

Table 2.44 A-PMD ch0 Internal signal connection specification: Input

ch	Input/output	Functional input	Signal name	Source		
				Peripheral function	Input signal	Signal name
A-PMD ch0	Input	OVV state signal (AD monitoring function 0)	ADACMP0L_N	ADC unit A	Monitor function output0 for PMD protect function	ADACP0L_N
		OVV state signal (AD monitoring function 1)	ADACMP1L_N		Monitor function output1 for PMD protect function	ADACP1L_N
		ADC conversion complete interrupt A (PMD0DBG)	INTADAPDA		ADC conversion complete interrupt A	INTADAPDA
		ADC conversion complete interrupt B (PMD0DBG)	INTADAPDB		ADC conversion complete interrupt B	INTADAPDB
		ADC under conversion flag (PMD0DBG)	ADABUSY		ADC under conversion flag	ADABUSY
		Commutation trigger (ENC position detection sync)	INTENC00	A-ENC32 ch0	Encoder input interrupt 0	INTENC00
		Commutation trigger (ENC MCMP completion sync)	ENC0CTRGO		The commutation trigger	ENC0CTRGO
		Commutation trigger (General purpose timer sync)	PMD0TMR		T32A ch3	Timer register A0 match trigger

Table 2.45 A-PMD ch0 Internal signal connection specification: Output

ch	Input/output	Functional Output	Signal name	Destination		
				Peripheral function	Output signal	Signal name
A-PMD ch0	Output	ADC synchronous sampling Output 0	PMD0TRG0	ADC unit A	PMD trigger 0	PMDTRG0
		ADC synchronous sampling Output 1	PMD0TRG1		PMD trigger 1	PMDTRG1
		ADC synchronous sampling Output 2	PMD0TRG2		PMD trigger 2	PMDTRG2
		ADC synchronous sampling Output 3	PMD0TRG3		PMD trigger 3	PMDTRG3
		ADC synchronous sampling Output 4	PMD0TRG4		PMD trigger 4	PMDTRG4
		ADC synchronous sampling Output 5	PMD0TRG5		PMD trigger 5	PMDTRG5
		PWM signal for the encoder input	PMD0PWMON	A-ENC32 ch0	The PWM signal for a sampling	ENC0PWMON

2.9. Advanced Encoder Input Circuit (32-bit) (A-ENC32)

2.9.1. Built-in channel

The built-in channel for each product is shown in the following table.

Table 2.46 A-ENC32 Built-in channel

Product	A-ENC32 Built-in channel (✓: Available, -: N/A)
	ch0
M3HQ	✓
M3HP	✓
M3HN	✓
M3HM	✓
M3HL	✓

2.9.2. Functional pin and port

The functional terminal is assigned to the following ports.

Table 2.47 A-ENC32 Functional pin and port

Channel	Functional pin		Signal name	Port	Product table (✓: Available, -: N/A)				
					M3HQ	M3HP	M3HN	M3HM	M3HL
A-ENC32 ch0	ENC0A	Input	ENC0A	PA0	✓	✓	✓	✓	✓
	ENC0B	Input	ENC0B	PA1	✓	✓	✓	✓	✓
	ENC0Z	Input	ENC0Z	PA2	✓	✓	✓	✓	✓

2.9.3. Internal signal connection specification

2.9.3.1. T32A/A-PMD connection

The advanced encoder input circuit is connected with the peripheral function inside, as shown in the following tables. "-" in a table does not have an applicable function.

Table 2.48 A-ENC32 Internal signal connection specification: Input

ch	Input/output	Functional input	Signal name	Source		
				Peripheral function	Input signal	Signal name
A-ENC32 ch0	Input	General purpose timer output signal	ENC0PSGI	T32A ch5	T32A ch5 Timer A output	T32A05OUTA
		The PWM signal for a sampling	ENC0PWMON	A-PMD ch0	PWM signal for the encoder input	PMD0PWMON

Table 2.49 A-ENC32 Internal signal connection specification: Output

ch	Input/output	Functional Output	Signal name	Trigger selector	Destination		
					Peripheral function	Output signal	Signal name
A-ENC32 ch0	Output	Divided pulse signal	ENC0TIMPLS	[TSEL1CR0] <INSEL1[2:0]> (<INSEL65[2:0]> (Note)	T32A ch5	T32A ch5 Timer A internal trigger input	T32A05TRGINAPHCK
		The commutation trigger	ENC0CTRGO	-	A-PMD ch0	Commutation trigger (ENC MCMP completion sync)	ENC0CTRGO
		Encoder input interrupt 0	INTENC00	-		Commutation trigger (ENC position detection sync)	INTENC00

Note: The trigger source of the start trigger is selected by **[TSEL1CR0]**<INSEL1[2:0]>. For details on the connection destination, refer to "2.2. Trigger Selector (TRGSEL)".

2.10. 12-bit Analog to Digital Converter (ADC)

2.10.1. Built-in unit

The built-in unit for each product is shown in the following table.

Table 2.50 ADC Built-in unit

Product	ADC Built-in unit (✓: Available, -: N/A)
	unit A
M3HQ	✓
M3HP	✓
M3HN	✓
M3HM	✓
M3HL	✓

2.10.2. Functional pin and port

The functional pin is assigned to the port of the following table. There is also a channel which does not have a functional pin by a product.

Table 2.51 ADC Functional pin and a port

Input channel	Functional pin (Signal name)	Port	Product table (✓: Available, -: N/A)				
			M3HQ	M3HP	M3HN	M3HM	M3HL
ch0	AINA00	PD0	✓	✓	✓	✓	✓
ch1	AINA01	PD1	✓	✓	✓	✓	✓
ch2	AINA02	PD2	✓	✓	✓	✓	✓
ch3	AINA03	PD3	✓	✓	✓	-	-
ch4	AINA04	PE0	✓	✓	✓	✓	✓
ch5	AINA05	PE1	✓	✓	✓	✓	✓
ch6	AINA06	PE2	✓	✓	✓	✓	✓
ch7	AINA07	PE3	✓	✓	✓	✓	✓
ch8	AINA08	PE4	✓	✓	✓	✓	✓
ch9	AINA09	PE5	✓	✓	✓	✓	✓
ch10	AINA10	PE6	✓	✓	✓	✓	✓
ch11	AINA11	PF0	✓	✓	✓	✓	✓
ch12	AINA12	PF1	✓	✓	✓	✓	✓
ch13	AINA13	PF2	✓	✓	✓	-	-
ch14	AINA14	PF3	✓	✓	✓	-	-
ch15	AINA15	PF4	✓	✓	✓	-	-
ch16	AINA16	PF5	✓	✓	✓	-	-
ch17	AINA17	PF6	✓	✓	-	-	-
ch18	AINA18	PF7	✓	✓	-	-	-
ch19	AINA19	PD4	✓	-	-	-	-
ch20	AINA20	PD5	✓	-	-	-	-
ch21	AINA21	DAC0 (Note)	✓	✓	✓	✓	✓
ch22	AINA22	DAC1 (Note)	✓	✓	✓	✓	✓
ch23	AINA23	AVSS	✓	✓	✓	✓	✓
ch24	AINA24	AVDD5	✓	✓	✓	✓	✓

Note: The AD conversion result is affected by the load connected to the pin.

2.10.3. Clock for the ADC conversion

12-bit Analog to Digital Converter uses the clock shown in the following table for conversion clock.

Table 2.52 ADC Clock for the conversion

Clock
ADCLK

2.10.4. Set of mode setting register 2

Please be sure to set up the value of the following table about the setting value of the mode setting register 2 (*[ADxMOD2]*).

Table 2.53 Set of mode setting register 2

Register name	Value
<i>[ADxMOD2]</i> <MOD2[31:0]>	0x00000300

2.10.5. Set of trimming setting register

Please be sure to set up the value of the following table about the setting value of the trimming setting register (*[ADxTRM]*).

Table 2.54 Set of trimming setting register

Register name	Value
<i>[ADxTRM]</i> <TRM[31:0]>	0x00034000

2.10.6. DMA request

A 12-bit Analog to Digital Converter has the DMA request shown in the following table.

Table 2.55 ADC DMA request

unit	Request	Signal name	Trigger selector	DMA request channel			
				ch	unit	Single transmission	Burst transmission
ADC unit A	General purpose trigger DMA request	ADATRQ_DMAREQ	<i>[TSEL0CR4]</i> <INSEL19[2:0]> (Note1)	14	B	-	✓
	Single conversion DMA request	ADASGL_DMAREQ				-	✓
	Continuous conversion DMA request	ADACNT_DMAREQ				-	✓

Note1: The trigger source of the start trigger is selected by *[TSEL0CR4]*<INSEL19[2:0]>. For details on the connection destination, refer to "2.2. Trigger Selector (TRGSEL)".

Note2: ✓: Available, -: N/A

2.10.7. Internal signal connection specification

2.10.7.1. Start-trigger connection specification

The 12-bit Analog to Digital Converter has the AD translation function by the trigger signal.

The input trigger signal which has a register name in the trigger selector column of the following table should select the input trigger used by a trigger selector. "-" in a table does not have an applicable function.

Table 2.56 ADC Start trigger connection specification

Destination (signal name)	Starting trigger		
	Trigger selector	Input trigger signal	Signal name
PMDTRG0	-	PMD trigger 0	PMD0TRG0
PMDTRG1	-	PMD trigger 1	PMD0TRG1
PMDTRG2	-	PMD trigger 2	PMD0TRG2
PMDTRG3	-	PMD trigger 3	PMD0TRG3
PMDTRG4	-	PMD trigger 4	PMD0TRG4
PMDTRG5	-	PMD trigger 5	PMD0TRG5
PMDTRG6	[TSEL0CR9] <INSEL37[2:0]> (Note)	PB1 pin	TRGIN0
		PA3 pin	TRGIN1
		PN3 pin	TRGIN2
		T32A ch7 Timer register A1 match trigger	T32A07TRGOUTCMPA1
		T32A ch7 Timer register B1 match trigger	T32A07TRGOUTCMPB1
		T32A ch7 Timer register C1 match trigger	T32A07TRGOUTCMPC1
PMDTRG7	-	-	-
PMDTRG8	-	-	-
PMDTRG9	-	-	-
PMDTRG10	-	-	-
PMDTRG11	-	-	-
ADATRGIN	[TSEL0CR9] <INSEL38[2:0]> (Note)	PB1 pin	TRGIN0
		PA3 pin	TRGIN1
		PN3 pin	TRGIN2
		T32A ch7 Timer register A1 match trigger	T32A07TRGOUTCMPA1
		T32A ch7 Timer register B1 match trigger	T32A07TRGOUTCMPB1
		T32A ch7 Timer register C1 match trigger	T32A07TRGOUTCMPC1

Note: The trigger source of the start trigger is selected by **[TSEL0CR9]**<INSELm[2:0]>. For details on the connection destination, refer to "2.2. Trigger Selector (TRGSEL)".

2.10.7.2. T32A/A-PMD connection

In addition to this, the 12-bit Analog to Digital Converter is connected with the peripheral function inside, as shown in the following table. "-" in a table does not have an applicable function.

Table 2.57 ADC Internal signal connection specification: Output

Input /output	Functional Output	Signal name	Trigger selector	Destination		
				Peripheral function		Signal name
Output	ADC unit A General purpose trigger interrupt	INTADATRG	[TSEL1CR1] <INSEL7[2:0]> (<INSEL71[2:0]>) (Note)	T32A ch7	Timer A ch7	T32A07TRGINAPCK
	ADC unit A Single conversion interrupt	INTADASGL				
	ADC unit A Continuous conversion interrupt	INTADACNT				
	ADC unit A Monitor function 0 interrupt	INTADACP0				
	ADC unit A Monitor function 1 interrupt	INTADACP1				
	ADC unit A Monitor function 0 output for PMD protect function	ADACP0L_N	-	A-PMD ch0	OVV state signal (AD monitor function 0)	ADACMP0L_N
	ADC unit A Monitor function 1 output for PMD protect function	ADACP1L_N	-		OVV state signal (AD monitor function 1)	ADACMP1L_N

Note: The trigger source of the start trigger is selected by **[TSEL1CR1]**<INSEL7[2:0]>. For details on the connection destination, refer to "2.2. Trigger Selector (TRGSEL)".

2.11. 8-bit Digital to Analog Converter (DAC)

2.11.1. Built-in channel

The built-in channel for each product is shown in the following table.

Table 2.58 DAC Built-in channel

Product	DAC Built-in channel (✓: Available, -: N/A)	
	ch0	ch1
M3HQ	✓	✓
M3HP	✓	✓
M3HN	✓	✓
M3HM	✓	✓
M3HL	✓	✓

2.11.2. Functional pin and a port

The functional terminal is assigned to the following ports.

Table 2.59 DAC Functional pin and a port

ch	Functional pin (Signal name)	Port	Product table (✓: Available, -: N/A)				
			M3HQ	M3HP	M3HN	M3HM	M3HL
DAC ch0	DAC0	PG0	✓	✓	✓	✓	✓
DAC ch1	DAC1	PG1	✓	✓	✓	✓	✓

Note: VREFH is connected to AVDD5 and VREFL is connected to AVSS.

2.12. Comparator (COMP)

2.12.1. Built-in channel

The built-in channel for each product is shown in the following table.

Table 2.60 Comparator Built-in channel

Product	COMP Built-in channel (✓: Available, -: N/A)
	ch0
M3HQ	✓
M3HP	✓
M3HN	✓
M3HM	✓
M3HL	✓

2.12.2. Functional pin and Destination

Functional pins are connected to destinations shown below.

Table 2.61 Comparator functional pin and destination

Functional pin		Signal name (Destination)	Product table (✓: Available, -: N/A)				
			M3HQ	M3HP	M3HN	M3HM	M3HL
AINA00	Input	AINA00 (ADC unit A)	✓	✓	✓	✓	✓
AINA01	Input	AINA01 (ADC unit A)	✓	✓	✓	✓	✓
DAC0 (VREFC)	Input	(DAC ch0)	✓	✓	✓	✓	✓
COMP output	Output	COMP (A-PMD ch0)	✓	✓	✓	✓	✓

2.13. Voltage Detection Circuit (LVD)

2.13.1. Built-in List

The following table shows the built-in list for each product.

Table 2.62 LVD Built-in List

Product	Built-in LVD (✓: Available, -: N/A)
M3HQ	✓
M3HP	✓
M3HN	✓
M3HM	✓
M3HL	✓

2.13.2. LVD Detection power supply

A voltage detecting circuit monitors the power supply of the following table.

Table 2.63 LVD Detection power supply

LVD Detection power supply	Power supply name
Digital power source terminal	DVDD5A, DVDD5B

2.14. 32-bit Timer Event Counter (T32A)

2.14.1. Built-in channel

The built-in channel for each product is shown in the following table.

Table 2.64 T32A Built-in channel

Product	T32A Built-in channel (✓: Available, -: N/A)							
	ch0	ch1	ch2	ch3	ch4	ch5	ch6	ch7
M3HQ	✓	✓	✓	✓	✓	✓	✓	✓
M3HP	✓	✓	✓	✓	✓	✓	✓	✓
M3HN	✓	✓	✓	✓	✓	✓	✓	✓
M3HM	✓	✓	✓	✓	✓	✓	✓	✓
M3HL	✓	✓	✓	✓	✓	✓	✓	✓

2.14.2. Functional pin and port

The functional pin is assigned to the port of the following tables.

Please use exclusively the same functional pin currently assigned to plurality.

There is also a channel which does not have a functional pin by a product.

Table 2.65 T32A Functional pin and a port (1/3)

ch	Functional pin (Signal name)		Port	Product table (✓: Available, -: N/A)				
				M3HQ	M3HP	M3HN	M3HM	M3HL
T32A ch0	T32A00OUTA	Output	PA0/PM0	✓/✓	✓/✓	✓/✓	✓/✓	✓/✓
	T32A00OUTB	Output	PA3/PM3	✓/✓	✓/✓	✓/✓	✓/-	✓/-
	T32A00OUTC	Output	PA0/PM0	✓/✓	✓/✓	✓/✓	✓/✓	✓/✓
	T32A00INA0	Input	PA1/PM1	✓/✓	✓/✓	✓/✓	✓/✓	✓/-
	T32A00INA1	Input	PA2/PM2	✓/✓	✓/✓	✓/✓	✓/✓	✓/-
	T32A00INB0	Input	PA4/PM4	✓/✓	✓/✓	✓/✓	✓/-	-/-
	T32A00INB1	Input	PA5/PM5	✓/✓	✓/✓	✓/✓	✓/-	-/-
	T32A00INC0	Input	PA1/PM1	✓/✓	✓/✓	✓/✓	✓/✓	✓/-
	T32A00INC1	Input	PA2/PM2	✓/✓	✓/✓	✓/✓	✓/✓	✓/-
T32A ch1	T32A01OUTA	Output	PB0/PP0	✓/✓	✓/✓	✓/✓	✓/✓	✓/-
	T32A01OUTB	Output	PB3	✓	✓	✓	✓	✓
	T32A01OUTC	Output	PB0/PP0	✓/✓	✓/✓	✓/✓	✓/✓	✓/-
	T32A01INA0	Input	PB1/PP1	✓/✓	✓/✓	✓/✓	✓/✓	✓/-
	T32A01INA1	Input	PB2/PP2	✓/✓	✓/✓	✓/✓	✓/✓	✓/-
	T32A01INB0	Input	PB4	✓	✓	✓	✓	-
	T32A01INB1	Input	PB5	✓	✓	✓	-	-
	T32A01INC0	Input	PB1/PP1	✓/✓	✓/✓	✓/✓	✓/✓	✓/-
	T32A01INC1	Input	PB2/PP2	✓/✓	✓/✓	✓/✓	✓/✓	✓/-

Table 2.66 T32A Functional signal and a port (2/3)

ch	Functional pin (Signal name)		Port	Product table (✓: Available, -: N/A)				
				M3HQ	M3HP	M3HN	M3HM	M3HL
T32A ch2	T32A02OUTA	Output	PC0/PR0	✓/✓	✓/✓	✓/✓	✓/-	✓/-
	T32A02OUTB	Output	PC3	✓	✓	✓	✓	✓
	T32A02OUTC	Output	PC0/PR0	✓/✓	✓/✓	✓/✓	✓/-	✓/-
	T32A02INA0	Input	PC1/PR1	✓/✓	✓/✓	✓/✓	✓/-	✓/-
	T32A02INA1	Input	PC2/PR2	✓/✓	✓/✓	✓/✓	✓/-	-/-
	T32A02INB0	Input	PC4	✓	✓	✓	✓	✓
	T32A02INB1	Input	PC5	✓	✓	✓	✓	-
	T32A02INC0	Input	PC1/PR1	✓/✓	✓/✓	✓/✓	✓/-	✓/-
	T32A02INC1	Input	PC2/PR2	✓/✓	✓/✓	✓/✓	✓/-	-/-
T32A ch3	T32A03OUTA	Output	PJ0	✓	✓	✓	✓	✓
	T32A03OUTB	Output	PJ3	✓	✓	✓	✓	✓
	T32A03OUTC	Output	PJ0	✓	✓	✓	✓	✓
	T32A03INA0	Input	PJ1	✓	✓	✓	✓	✓
	T32A03INA1	Input	PJ2	✓	✓	✓	✓	✓
	T32A03INB0	Input	PJ4	✓	✓	✓	✓	✓
	T32A03INB1	Input	PJ5	✓	✓	✓	✓	✓
	T32A03INC0	Input	PJ1	✓	✓	✓	✓	✓
	T32A03INC1	Input	PJ2	✓	✓	✓	✓	✓
T32A ch4	T32A04OUTA	Output	PK2	✓	✓	✓	✓	✓
	T32A04OUTB	Output	PK5	✓	✓	✓	✓	✓
	T32A04OUTC	Output	PK2	✓	✓	✓	✓	✓
	T32A04INA0	Input	PK3	✓	✓	✓	✓	✓
	T32A04INA1	Input	PK4	✓	✓	✓	✓	✓
	T32A04INB0	Input	PK6	✓	✓	✓	✓	✓
	T32A04INB1	Input	PK7	✓	✓	✓	✓	-
	T32A04INC0	Input	PK3	✓	✓	✓	✓	✓
	T32A04INC1	Input	PK4	✓	✓	✓	✓	✓
T32A ch5	T32A05OUTA	Output	PN0	✓	✓	✓	✓	-
	T32A05OUTB	Output	PN3	✓	✓	✓	✓	✓
	T32A05OUTC	Output	PN0	✓	✓	✓	✓	-
	T32A05INA0	Input	PN1	✓	✓	✓	✓	✓
	T32A05INA1	Input	PN2	✓	✓	✓	✓	✓
	T32A05INB0	Input	PN4	✓	✓	✓	✓	✓
	T32A05INB1	Input	PN5	✓	✓	✓	-	-
	T32A05INC0	Input	PN1	✓	✓	✓	✓	✓
	T32A05INC1	Input	PN2	✓	✓	✓	✓	✓

Table 2.67 T32A Functional pin and a port (3/3)

ch	Functional pin (Signal name)		Port	Product table (✓: Available, -: N/A)				
				M3HQ	M3HP	M3HN	M3HM	M3HL
T32A ch6	T32A06OUTA	Output	PL5/PT5	✓/✓	✓/-	✓/-	-/-	-/-
	T32A06OUTB	Output	PL2/PT2	✓/✓	✓/✓	✓/-	✓/-	✓/-
	T32A06OUTC	Output	PL5/PT5	✓/✓	✓/-	✓/-	-/-	-/-
	T32A06INA0	Input	PL6/PT6	✓/✓	✓/-	✓/-	-/-	-/-
	T32A06INA1	Input	PL7/PT7	✓/✓	✓/-	-/-	-/-	-/-
	T32A06INB0	Input	PL3/PT3	✓/✓	✓/✓	✓/-	✓/-	✓/-
	T32A06INB1	Input	PL4/PT4	✓/✓	✓/-	✓/-	✓/-	✓/-
	T32A06INC0	Input	PL6/PT6	✓/✓	✓/-	✓/-	-/-	-/-
	T32A06INC1	Input	PL7/PT7	✓/✓	✓/-	-/-	-/-	-/-
T32A ch7	T32A07OUTA	Output	PG2	✓	✓	-	-	-
	T32A07OUTB	Output	PG5	✓	✓	-	-	-
	T32A07OUTC	Output	PG2	✓	✓	-	-	-
	T32A07INA0	Input	PG3	✓	✓	-	-	-
	T32A07INA1	Input	PG4	✓	✓	-	-	-
	T32A07INB0	Input	PG6	✓	✓	-	-	-
	T32A07INB1	Input	PG7	✓	✓	-	-	-
	T32A07INC0	Input	PG3	✓	✓	-	-	-
	T32A07INC1	Input	PG4	✓	✓	-	-	-

2.14.3. Clock for prescaler

32-bit Timer Event Counter uses the clock shown in the following table for prescaler.

Table 2.68 T32A Clock for prescaler

Clock
ΦT0

2.14.4. Internal signal connection specification

The capture trigger signal which shows 32-bit Timer Event Counter in the following tables is connected.

The input trigger signal which has a register name in the trigger selector column of the following table should select the input trigger used by a trigger selector.

2.14.4.1. Capture trigger signal connection specification

Table 2.69 T32A Capture trigger signal connection specification (1/8)

ch		Trigger source			
		Capture trigger input signal name	Trigger selector	Input trigger signal	Signal name
T32A ch0	A	T32A00TRGINAPHCK (Other timer outputs)	-	-	-
		T32A00TRGINAPCK (Internal trigger input) (Refer to the Figure 2.2)	[TSEL0CR12] <INSEL50[2:0]> (Note)	PB1 pin	TRGIN0
				PA3 pin	TRGIN1
				PN3 pin	TRGIN2
				UART ch0 transmission completion trigger	UART0TXTRG
				UART ch0 reception completion trigger	UART0RXTRG
		[TSEL1CR3] <INSEL12[2:0]> (<INSEL76[2:0]>) (Note)	[TSEL0CR12]<INSEL50[2:0]> output	TRGSEL50 output	
			T32A ch0 timer register B0 match trigger	T32A00TRGOUTCMPB0	
			T32A ch0 timer register B1 match trigger	T32A00TRGOUTCMPB1	
			T32A ch0 timer B overflow trigger	T32A00TRGOUTOFB	
	T32A ch0 timer B underflow trigger		T32A00TRGOUTUFB		
	B	T32A00TRGINBPHCK (Other timer outputs)	T32A ch0 timer A output		T32A00OUTA
		T32A00TRGINBPCK (Other timer inputs)	[TSEL0CR12] <INSEL51[2:0]> (Note)	T32A ch0 timer register A0 match trigger	T32A00TRGOUTCMPA0
				T32A ch0 timer register A1 match trigger	T32A00TRGOUTCMPA1
				T32A ch0 timer A overflow trigger	T32A00TRGOUTOFA
				T32A ch0 timer A underflow trigger	T32A00TRGOUTUFA
	C	T32A00TRGINCPHCK (Other timer outputs)	-	-	-
		T32A00TRGINCPCK (Internal trigger input)	[TSEL0CR13] <INSEL52[2:0]> (Note)	T32A ch7 timer register C0 match trigger	T32A07TRGOUTCMPC0
				T32A ch7 timer register C1 match trigger	T32A07TRGOUTCMPC1
T32A ch7 timer C overflow trigger				T32A07TRGOUTOFC	
T32A ch7 timer C underflow trigger				T32A07TRGOUTUFC	

Note: The trigger source of the internal trigger is selected by [TSELxCRn]<INSELM[2:0]>. For details of the connected destination, refer to "2.2. Trigger Selector (TRGSEL)".

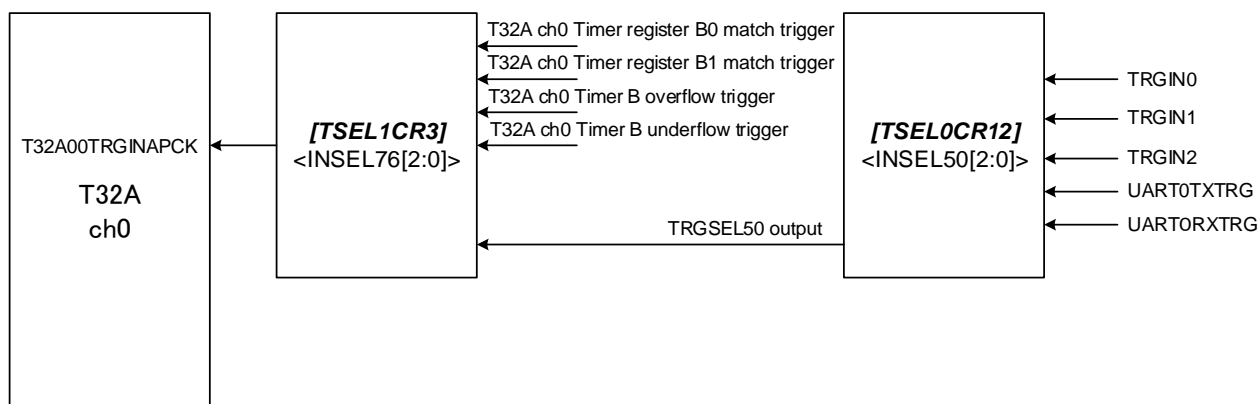

Figure 2.2 Trigger and TRGSEL connection overview (T32A ch0)

Table 2.70 T32A Capture trigger signal connection specification (2/8)

ch		Trigger source				
		Capture trigger input signal name	Trigger selector	Input trigger signal	Signal name	
T32A ch1	A	T32A01TRGINAPHCK (Other timer outputs)	-	-	-	
		T32A01TRGINAPCK (Internal trigger input) (Refer to the Figure 2.3)	[TSEL0CR13] <INSEL53[2:0]> (Note)	PB1 pin	TRGIN0	
				PA3 pin	TRGIN1	
				PN3 pin	TRGIN2	
				UART ch1 transmission completion trigger	UART1TXTRG	
				UART ch1 reception completion trigger	UART1RXTRG	
				EI2C ch0 status interrupt/I2C ch0 interrupt	INTI2C0ST/INTI2C0	
		[TSEL1CR3] <INSEL13[2:0]> (<INSEL77[2:0]> (Note)	[TSEL0CR13]<INSEL53[2:0]> output	TRGSEL53 output		
			T32A ch1 timer register B0 match trigger	T32A01TRGOUTCMPB0		
			T32A ch1 timer register B1 match trigger	T32A01TRGOUTCMPB1		
			T32A ch1 timer B overflow trigger	T32A01TRGOUTOFB		
			T32A ch1 timer B underflow trigger	T32A01TRGOUTUFB		
			B	T32A01TRGINBPHCK (Other timer outputs)	T32A ch1 timer A output	
	T32A01TRGINBPCK (Internal trigger input)			[TSEL0CR13] <INSEL54[2:0]> (Note)	T32A ch1 timer register A0 match trigger	T32A01TRGOUTCMPA0
	T32A ch1 timer register A1 match trigger	T32A01TRGOUTCMPA1				
	T32A ch1 timer A overflow trigger	T32A01TRGOUTOFA				
	T32A ch1 timer A underflow trigger	T32A01TRGOUTUFA				
	C	T32A01TRGINCPHCK (Other timer outputs)	T32A ch0 timer C output		T32A00OUTC	
		T32A01TRGINCPCK (Internal trigger input)	[TSEL0CR13] <INSEL55[2:0]> (Note)	T32A ch0 timer register C0 match trigger	T32A00TRGOUTCMPC0	
				T32A ch0 timer register C1 match trigger	T32A00TRGOUTCMPC1	
T32A ch0 timer C overflow trigger				T32A00TRGOUTOFC		
T32A ch0 timer C underflow trigger				T32A00TRGOUTUFC		

Note: The trigger source of the internal trigger is selected by [TSELxCRn]<INSELM[2:0]>. For details of the connected destination, refer to "2.2. Trigger Selector (TRGSEL)".

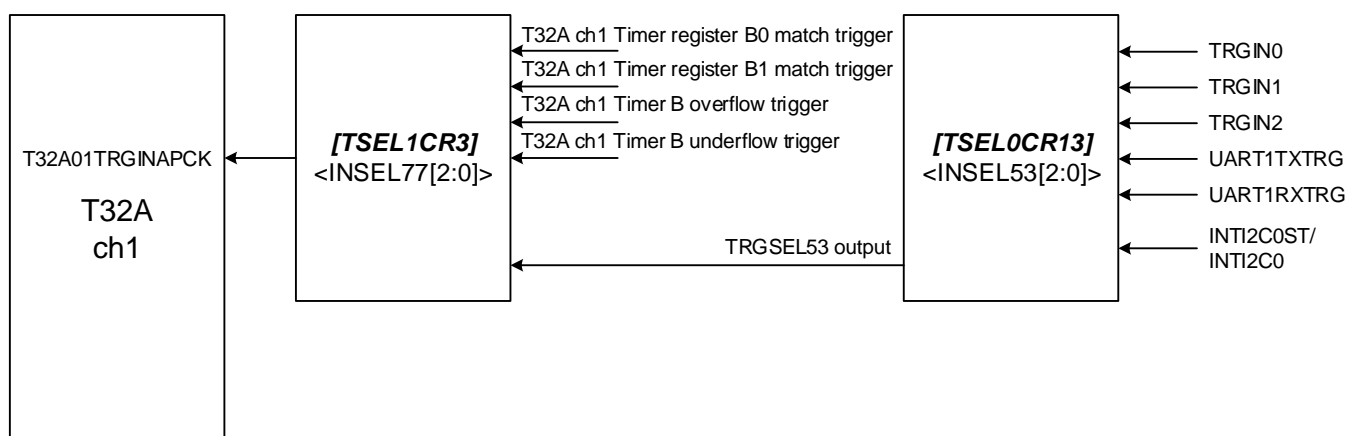

Figure 2.3 Trigger and TRGSEL connection overview (T32A ch1)

Table 2.71 T32A Capture trigger signal connection specification (3/8)

ch		Trigger source			
		Capture trigger input signal name	Trigger selector	Input trigger signal	Signal name
T32A ch2	A	T32A02TRGINAPHCK (Other timer outputs)	-	-	-
		T32A02TRGINAPCK (Internal trigger input) (Refer to the Figure 2.4)	[TSEL0CR14] <INSEL56[2:0]> (Note)	PB1 pin	TRGIN0
				PA3 pin	TRGIN1
				PN3 pin	TRGIN2
				UART ch2 transmission completion trigger	UART2TXTRG
				UART ch2 reception completion trigger	UART2RXTRG
				TSPI ch0 transmit complete trigger	TSPI0TXEND
				TSPI ch0 receive complete trigger	TSPI0RXEND
				EI2C ch1 status interrupt/I2C ch1 interrupt	INTI2C1ST/INTI2C1
				[TSEL0CR14]<INSEL56[2:0]> output	TRGSEL56 output
				T32A ch2 timer register B0 match trigger	T32A02TRGOUTCMPB0
		T32A ch2 timer register B1 match trigger	T32A02TRGOUTCMPB1		
		T32A ch2 timer B overflow trigger	T32A02TRGOUTOFB		
		T32A ch2 timer B underflow trigger	T32A02TRGOUTUFB		
	B	T32A02TRGINBPHCK (Other timer outputs)	T32A ch2 timer A output		T32A02OUTA
		T32A02TRGINBPCK (Internal trigger input)	[TSEL0CR14] <INSEL57[2:0]> (Note)	T32A ch2 timer register A0 match trigger	T32A02TRGOUTCMPA0
				T32A ch2 timer register A1 match trigger	T32A02TRGOUTCMPA1
				T32A ch2 timer A overflow trigger	T32A02TRGOUTOFA
				T32A ch2 timer A underflow trigger	T32A02TRGOUTUFA
		C	T32A02TRGINCPHCK (Other timer outputs)	-	-
T32A02TRGINCPCK (Internal trigger input)	[TSEL0CR14] <INSEL58[2:0]> (Note)		T32A ch1 timer register C0 match trigger	T32A01TRGOUTCMPC0	
			T32A ch1 timer register C1 match trigger	T32A01TRGOUTCMPC1	
			T32A ch1 timer C overflow trigger	T32A01TRGOUTOFC	
			T32A ch1 timer C underflow trigger	T32A01TRGOUTUFC	

Note: The trigger source of the internal trigger is selected by [TSELxCRn]<INSELM[2:0]>. For details of the connected destination, refer to "2.2. Trigger Selector (TRGSEL)".

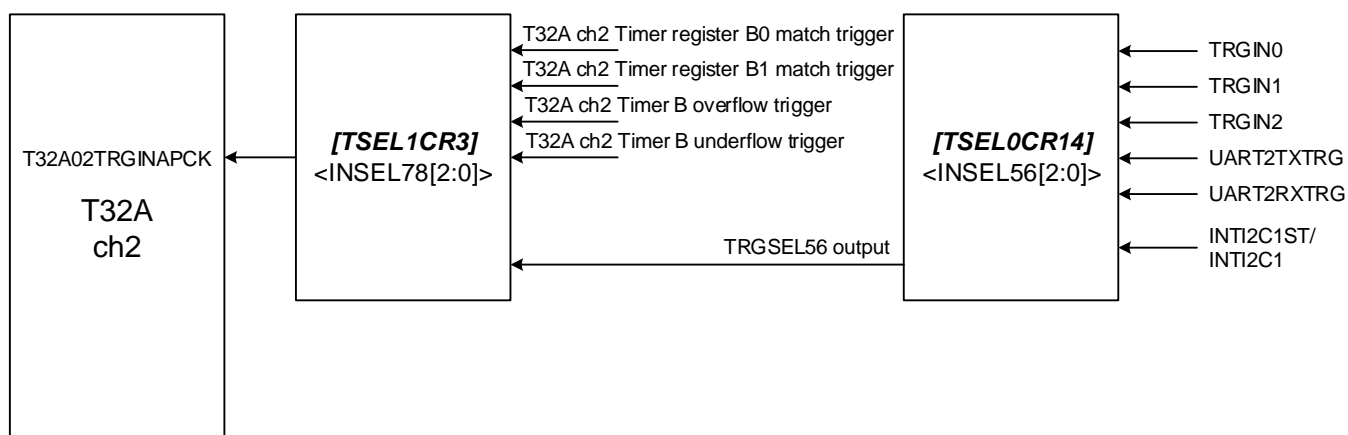

Figure 2.4 Trigger and TRGSEL connection overview (T32A ch2)

Table 2.72 T32A Capture trigger signal connection specification (4/8)

ch		Trigger source			
		Capture trigger input signal name	Trigger selector	Input trigger signal	Signal name
T32A ch3	A	T32A03TRGINAPHCK (Other timer outputs)	-	-	-
		T32A03TRGINAPCK (Internal trigger input) (Refer to the Figure 2.5)	[TSEL0CR14] <INSEL59[2:0]> (Note1)	PB1 pin	TRGIN0
				PA3 pin	TRGIN1
				PN3 pin	TRGIN2
				UART ch3 transmission completion trigger	UART3TXTRG
				UART ch3 reception completion trigger	UART3RXTRG
				TSPI ch1 transmit complete trigger (Note2)	TSPI1TXEND
				TSPI ch1 receive complete trigger (Note2)	TSPI1RXEND
				EI2C ch2 status interrupt/I2C ch2 interrupt	INTI2C2ST/INTI2C2
				[TSEL0CR14]<INSEL59[2:0]> output	TRGSEL59 output
				[TSEL1CR3] <INSEL15[2:0]> (<INSEL79[2:0]> (Note1)	T32A ch3 timer register B0 match trigger
		T32A ch3 timer register B1 match trigger	T32A03TRGOUTCMPB1		
		T32A ch3 timer B overflow trigger	T32A03TRGOUTOFB		
	T32A ch3 timer B underflow trigger	T32A03TRGOUTUFB			
	B	T32A03TRGINBPHCK (Other timer outputs)	T32A ch3 timer A output		T32A03OUTA
		T32A03TRGINBPCK (Internal trigger input)	[TSEL0CR15] <INSEL60 [2:0]> (Note1)	T32A ch3 timer register A0 match trigger	T32A03TRGOUTCMPA0
				T32A ch3 timer register A1 match trigger	T32A03TRGOUTCMPA1
				T32A ch3 timer A overflow trigger	T32A03TRGOUTOFA
				T32A ch3 timer A underflow trigger	T32A03TRGOUTUFA
	C	T32A03TRGINCPHCK (Other timer outputs)	T32A ch2 timer C output		T32A02OUTC
T32A03TRGINCPCK (Internal trigger input)		[TSEL0CR15] <INSEL61 [2:0]> (Note1)	T32A ch2 timer register C0 match trigger	T32A02TRGOUTCMPC0	
			T32A ch2 timer register C1 match trigger	T32A02TRGOUTCMPC1	
			T32A ch2 timer C overflow trigger	T32A02TRGOUTOFC	

Note1: The trigger source of the internal trigger is selected by [TSELxCRn]<INSELM[2:0]>. For details of the connected destination, refer to "2.2. Trigger Selector (TRGSEL)".

Note2: There is no TSPI ch1 in M3HL.

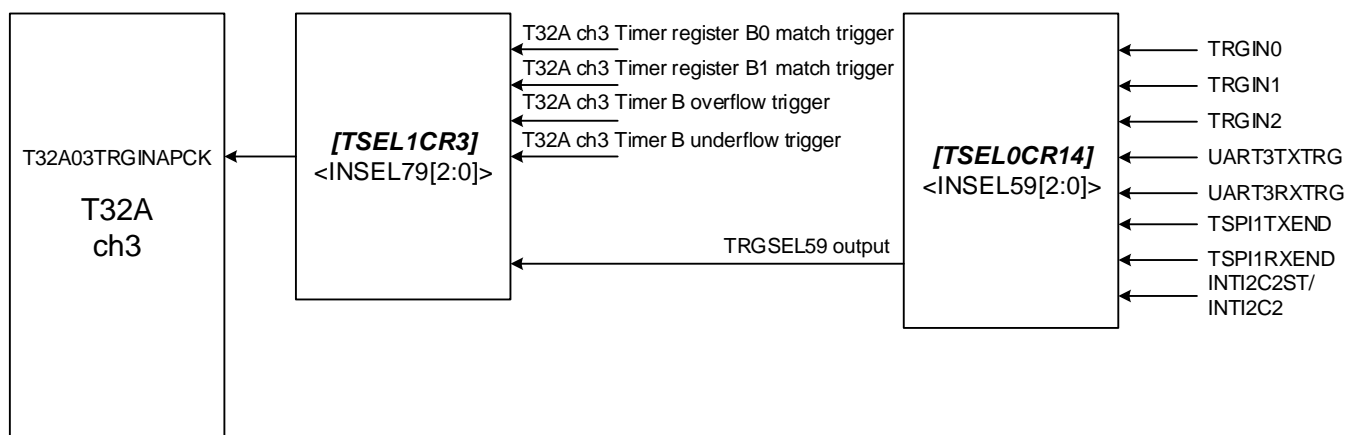

Figure 2.5 Trigger and TRGSEL connection overview (T32A ch3)

Table 2.73 T32A Capture trigger signal connection specification (5/8)

ch		Trigger source			
		Capture trigger input signal name	Trigger selector	Input trigger signal	Signal name
T32A ch4	A	T32A04TRGINAPHCK (Other timer outputs)	-	-	-
		T32A04TRGINAPCK (Internal trigger input) (Refer to the Figure 2.6.)	[TSEL0CR15] <INSEL62[2:0]> (Note1)	PB1 pin	TRGIN0
				PA3 pin	TRGIN1
				PN3 pin	TRGIN2
				UART ch4 transmission completion trigger	UART4TXTRG
				UART ch4 reception completion trigger	UART4RXTRG
				TSPI ch2 transmit complete trigger (Note2)	TSPI2TXEND
				TSPI ch2 receive complete trigger (Note2)	TSPI2RXEND
				EI2C ch3 status interrupt/I2C ch3 interrupt (Note3)	INTI2C3ST/INTI2C3
				[TSEL0CR15]<INSEL62[2:0]> output	TRGSEL62 output
				T32A ch4 timer register B0 match trigger	T32A04TRGOUTCMPB0
		T32A ch4 timer register B1 match trigger	T32A04TRGOUTCMPB1		
		T32A ch4 timer B overflow trigger	T32A04TRGOUTOFB		
		T32A ch4 timer B underflow trigger	T32A04TRGOUTUFB		
	B	T32A04TRGINBPHCK (Other timer outputs)	T32A ch4 timer A output		T32A04OUTA
		T32A04TRGINBPCK (Internal trigger input)	[TSEL0CR15] <INSEL63[2:0]> (Note1)	T32A ch4 timer register A0 match trigger	T32A04TRGOUTCMPA0
				T32A ch4 timer register A1 match trigger	T32A04TRGOUTCMPA1
				T32A ch4 timer A overflow trigger	T32A04TRGOUTOFA
	T32A ch4 timer A underflow trigger			T32A04TRGOUTUFA	
	C	T32A04TRGINCPHCK (Other timer outputs)	-	-	-
T32A04TRGINCPCK (Internal trigger input)		[TSEL1CR0] <INSEL0[2:0]> (<INSEL64[2:0]>) (Note1)	T32A ch3 timer register C0 match trigger	T32A03TRGOUTCMPC0	
			T32A ch3 timer register C1 match trigger	T32A03TRGOUTCMPC1	
			T32A ch3 timer C overflow trigger	T32A03TRGOUTOFC	
			T32A ch3 timer C underflow trigger	T32A03TRGOUTUFC	

Note1: The trigger source of the start trigger is selected by [TSELxCRn]<INSELM[2:0]>. For details of the connected destination, refer to "2.2. Trigger Selector (TRGSEL)".

Note2: There is no TSPI ch2 and ch3 in M3HL.

Note3: There is no EI2C/I2C ch3 in M3HN, M3HM, and M3HL.

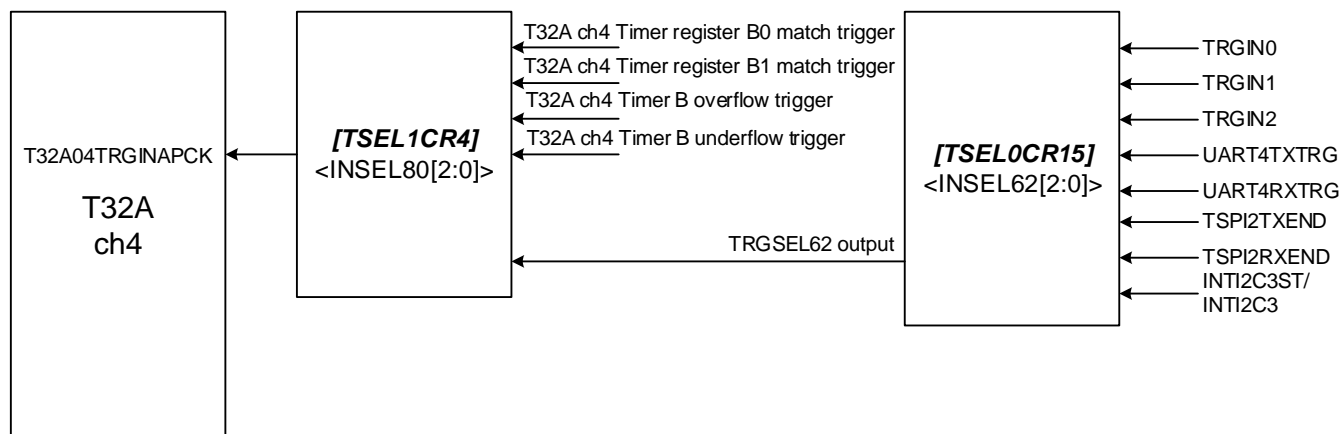

Figure 2.6 Trigger and TRGSEL connection overview (T32A ch4)

Table 2.74 T32A Capture trigger signal connection specification (6/8)

ch		Trigger source			
		Capture trigger input signal name	Trigger selector	Input trigger signal	Signal name
T32A ch5	A	T32A05TRGINAPHCK (Other timer outputs)	-	-	-
		T32A05TRGINAPCK (Internal trigger input) (Refer to the Figure 2.7.)	[TSEL1CR0] <INSEL1[2:0]> (<INSEL65[2:0]> (Note1)	PB1 pin	TRGIN0
				PA3 pin	TRGIN1
				PN3 pin	TRGIN2
				UART ch5 transmission completion trigger	UART5TXTRG
				UART ch5 reception completion trigger	UART5RXTRG
				TSPI ch3 transmit complete trigger (Note2)	TSPI3TXEND
				TSPI ch3 receive complete trigger (Note2)	TSPI3RXEND
				A-ENC32 ch0 Dividing pulse signal	ENC0TIMPLS
				[TSEL1CR0]<INSEL65[2:0]> output	TRGSEL65 output
				T32A ch5 timer register B0 match trigger	T32A05TRGOUTCMPB0
		T32A ch5 timer register B1 match trigger	T32A05TRGOUTCMPB1		
		T32A ch5 timer B overflow trigger	T32A05TRGOUTOFB		
	T32A ch5 timer B underflow trigger	T32A05TRGOUTUFB			
	B	T32A05TRGINBPHCK (Other timer outputs)	T32A ch5 timer A output		T32A05OUTA
		T32A05TRGINBPCK (Internal trigger input)	[TSEL1CR0] <INSEL2[2:0]> (<INSEL66[2:0]> (Note1)	T32A ch5 timer register A0 match trigger	T32A05TRGOUTCMPA0
				T32A ch5 timer register A1 match trigger	T32A05TRGOUTCMPA1
				T32A ch5 timer A overflow trigger	T32A05TRGOUTOFA
				T32A ch5 timer A underflow trigger	T32A05TRGOUTUFA
	C	T32A05TRGINCPHCK (Other timer outputs)	T32A ch4 timer C output		T32A04OUTC
T32A05TRGINCPCK (Internal trigger input)		[TSEL1CR0] <INSEL3[2:0]> (<INSEL67[2:0]> (Note1)	T32A ch4 timer register C0 match trigger	T32A04TRGOUTCMPC0	
			T32A ch4 timer register C1 match trigger	T32A04TRGOUTCMPC1	
			T32A ch4 timer C overflow trigger	T32A04TRGOUTOFC	
			T32A ch4 timer C underflow trigger	T32A04TRGOUTUFC	

Note1: The trigger source of the start trigger is selected by [TSEL1CRn]<INSELM[2:0]>. For details of the connected destination, refer to "2.2. Trigger Selector (TRGSEL)".

Note2: There is no TSPI ch2, ch3 in M3HL.

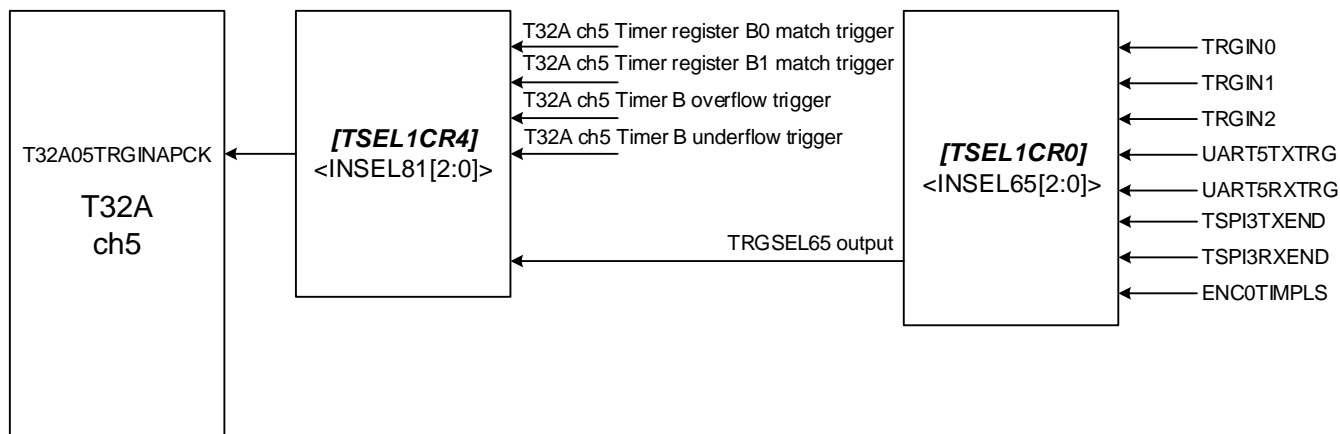

Figure 2.7 Trigger and TRGSEL connection overview (T32A ch5)

Table 2.75 T32A Capture trigger signal connection specification (7/8)

ch		Trigger source			
		Capture trigger input signal name	Trigger selector	Input trigger signal	Signal name
T32A ch6	A	T32A06TRGINAPHCK (Other timer outputs)	-	-	-
		T32A06TRGINAPCK (Internal trigger input) (Refer to the Figure 2.8.)	[TSEL1CR1] <INSEL4[2:0]> (<INSEL68[2:0]> (Note1)	PB1 pin	TRGIN0
				PA3 pin	TRGIN1
				PN3 pin	TRGIN2
				TSPI ch4 transmit complete trigger (Note2)	TSPI4TXEND
				TSPI ch4 receive complete trigger (Note2)	TSPI4RXEND
				ELOSC clock	fs
			[TSEL1CR4] <INSEL18[2:0]> (<INSEL82[2:0]> (Note1)	[TSEL1CR1]<INSEL68[2:0]> Output	TRGSEL68 output
				T32A ch6 timer register B0 match trigger	T32A06TRGOUTCMPB0
				T32A ch6 timer register B1 match trigger	T32A06TRGOUTCMPB1
				T32A ch6 timer B overflow trigger	T32A06TRGOUTOFB
		T32A ch6 timer B underflow trigger	T32A06TRGOUTUFB		
	UART ch6 transmission completion trigger	UART6TXTRG			
	UART ch6 reception completion trigger	UART6RXTRG			
	B	T32A06TRGINBPHCK (Other timer outputs)	T32A ch6 timer A output		T32A06OUTA
		T32A06TRGINBPCK (Internal trigger input)	[TSEL1CR1] <INSEL5[2:0]> (<INSEL69[2:0]> (Note1)	T32A ch6 timer register A0 match trigger	T32A06TRGOUTCMPA0
				T32A ch6 timer register A1 match trigger	T32A06TRGOUTCMPA1
				T32A ch6 timer A overflow trigger	T32A06TRGOUTOFA
				T32A ch6 timer A underflow trigger	T32A06TRGOUTUFA
	C	T32A06TRGINCPHCK (Other timer outputs)	-	-	-
T32A06TRGINCPCK (Internal trigger input)		[TSEL1CR1] <INSEL6[2:0]> (<INSEL70[2:0]> (Note1)	T32A ch5 timer register C0 match trigger	T32A05TRGOUTCMPC0	
			T32A ch5 timer register C1 match trigger	T32A05TRGOUTCMPC1	
			T32A ch5 timer C overflow trigger	T32A05TRGOUTOFC	
			T32A ch5 timer C underflow trigger	T32A05TRGOUTUFC	

Note1: The trigger source of the start trigger is selected by [TSEL1CRn]<INSELM[2:0]>. For details of the connected destination, refer to "2.2. Trigger Selector (TRGSEL)".

Note2: There is no TSPI channel 4 in M3HN, M3HM, M3HL.

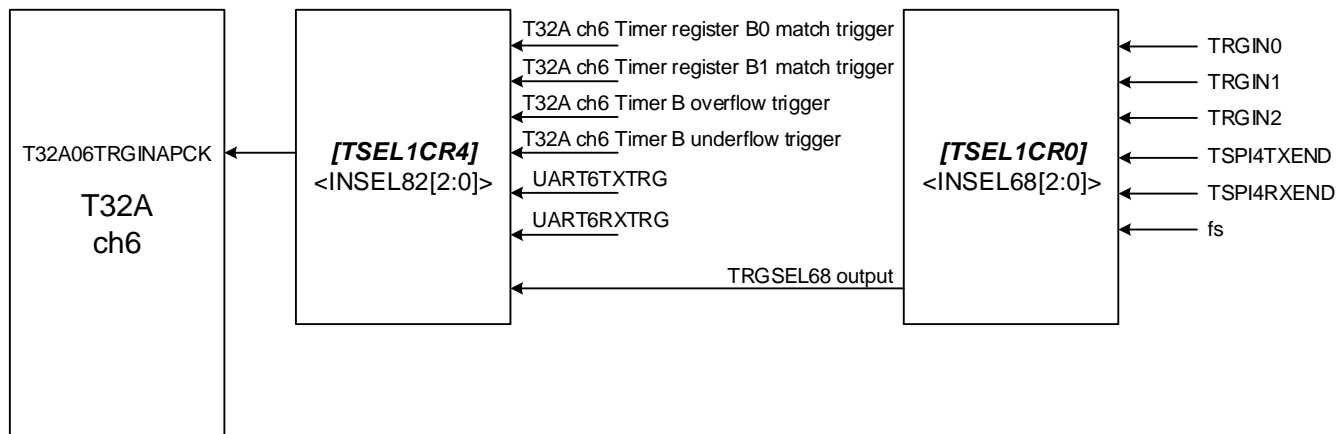

Figure 2.8 Trigger and TRGSEL connection overview (T32A ch6)

Table 2.76 T32A Capture trigger signal connection specification (8/8)

ch		Trigger source					
		Capture trigger input signal name	Trigger selector	Input trigger signal	Signal name		
T32A ch7	A	T32A07TRGINAPHCK (Other timer outputs)	-	-	-		
		T32A07TRGINAPCK (Internal trigger input) (Refer to the Figure 2.9.)	[TSEL1CR1] <INSEL7[2:0]> (<INSEL71[2:0]>) (Note1)	PB1 pin	TRGIN0		
				PA3 pin	TRGIN1		
				PN3 pin	TRGIN2		
				ADC unit A general purpose trigger interrupt	INTADATRG		
				ADC unit A single conversion interrupt	INTADASGL		
				ADC unit A continuous conversion interrupt	INTADACNT		
				ADC unit A monitor function interrupt 0	INTADACP0		
			ADC unit A monitor function interrupt 1	INTADACP1			
			[TSEL1CR1]<INSEL71[2:0]> output	TRGSEL71 output			
			T32A ch7 timer register B0 match trigger	T32A07TRGOUTCMPB0			
			T32A ch7 timer register B1 match trigger	T32A07TRGOUTCMPB1			
			T32A ch7 timer B overflow trigger	T32A07TRGOUTOFB			
			T32A ch7 timer B underflow trigger	T32A07TRGOUTUFB			
	UART ch7 transmission completion trigger (Note2)	UART7TXTRG					
	UART ch7 reception completion trigger (Note2)	UART7RXTRG					
	B	T32A07TRGINBPHCK (Other timer outputs)	T32A ch7 timer A output			T32A07OUTA	
		T32A07TRGINBPCK (Internal trigger input)	[TSEL1CR2] <INSEL8[2:0]> (<INSEL72[2:0]>) (Note1)	T32A ch7 timer register A0 match trigger	T32A07TRGOUTCMPA0		
				T32A ch7 timer register A1 match trigger	T32A07TRGOUTCMPA1		
				T32A ch7 timer A overflow trigger	T32A07TRGOUTOFA		
				T32A ch7 timer A underflow trigger	T32A07TRGOUTUFA		
		C	T32A07TRGINCPHCK (Other timer outputs)	T32A ch6 timer C output			T32A06OUTC
			T32A07TRGINCPCK (Internal trigger input)	[TSEL1CR2] <INSEL9[2:0]> (<INSEL73[2:0]>) (Note1)	T32A ch6 timer register C0 match trigger	T32A06TRGOUTCMPC0	
					T32A ch6 timer register C1 match trigger	T32A06TRGOUTCMPC1	
T32A ch6 timer C overflow trigger					T32A06TRGOUTOFC		
T32A ch6 timer C underflow trigger					T32A06TRGOUTUFC		

Note1: The trigger source of the start trigger is selected by [TSEL1CRn]<INSELM[2:0]>. For details of the connected destination, refer to "2.2. Trigger Selector (TRGSEL)".

Note2: There is no UART ch7 in M3HM and M3HL.

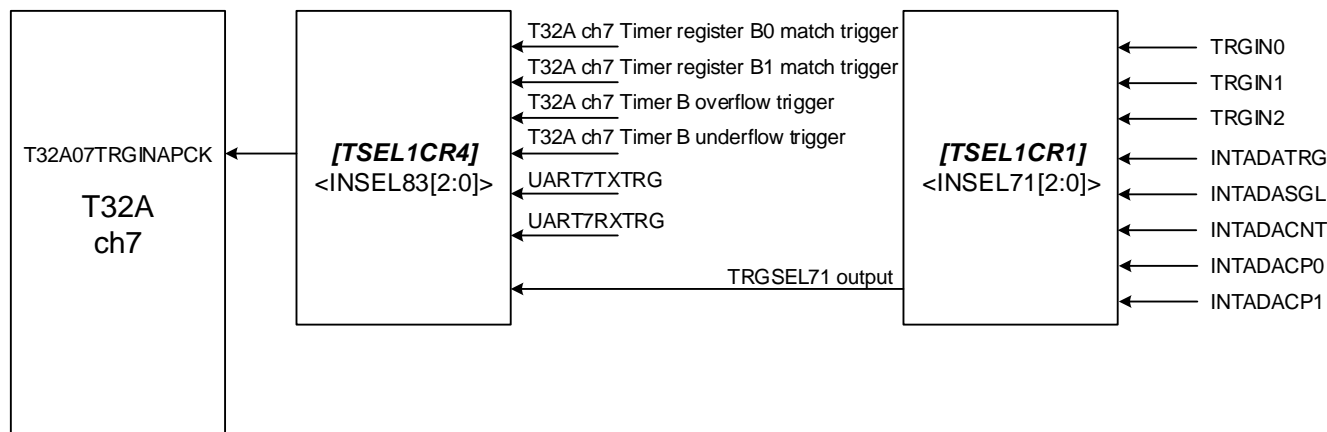

Figure 2.9 Trigger and TRGSEL connection overview (T32A ch7)

2.14.4.2. Synchronous control connection specification

The timer synchronous connection specification of a 32-bit Timer Event Counter is shown in the following tables.

Table 2.77 T32A Synchronous control connection specification (1/2)

Master				Slave					
ch	Timer	Function (output)	Signal name	ch	Timer	Function (input)	Signal name		
T32A ch0	A	Trigger output for synchronous start A	T32A00SYNCSTARTOUTA	ch0	B	Synchronous start at trigger input B	T32A00SYNCSTARTB		
				ch1	A	Synchronous start at trigger input A	T32A01SYNCSTARTA		
		B	Synchronous start at trigger input B		T32A01SYNCSTARTB				
		Trigger output for synchronous stop A	T32A00SYNCSTOPOUTA	ch0	B	Synchronous stop at trigger input B	T32A00SYNCSTOPB		
				ch1	A	Synchronous stop at trigger input A	T32A01SYNCSTOPA		
		B	Synchronous stop at trigger input B		T32A01SYNCSTOPB				
	Trigger output for synchronous reload A	T32A00SYNCRELOADOUTA	ch0	B	Synchronous reload at trigger input B	T32A00SYNCRELOADB			
			ch1	A	Synchronous reload at trigger input A	T32A01SYNCRELOADA			
	B	Synchronous reload at trigger input B		T32A01SYNCRELOADB					
	C	Trigger output for synchronous start C	T32A00SYNCSTARTOUTC	ch1	C	Synchronous start at trigger input C	T32A01SYNCSTARTC		
						Trigger output for synchronous stop C	T32A00SYNCSTOPOUTC	Synchronous stop at trigger input C	T32A01SYNCSTOPC
						Trigger output for synchronous reload C	T32A00SYNCRELOADOUTC	Synchronous reload at trigger input C	T32A01SYNCRELOADC
TA32 ch2	A	Trigger output for synchronous start A	T32A02SYNCSTARTOUTA	ch2	B	Synchronous start at trigger input B	T32A02SYNCSTARTB		
				ch3	A	Synchronous start at trigger input A	T32A03SYNCSTARTA		
		B	Synchronous start at trigger input B		T32A03SYNCSTARTB				
		Trigger output for synchronous stop A	T32A02SYNCSTOPOUTA	ch2	B	Synchronous stop at trigger input B	T32A02SYNCSTOPB		
				ch3	A	Synchronous stop at trigger input A	T32A03SYNCSTOPA		
		B	Synchronous stop at trigger input B		T32A03SYNCSTOPB				
	Trigger output for synchronous reload A	T32A02SYNCRELOADOUTA	ch2	B	Synchronous reload at trigger input B	T32A02SYNCRELOADB			
			ch3	A	Synchronous reload at trigger input A	T32A03SYNCRELOADA			
	B	Synchronous reload at trigger input B		T32A03SYNCRELOADB					
	C	Trigger output for synchronous start C	T32A02SYNCSTARTOUTC	ch3	C	Synchronous start at trigger input C	T32A03SYNCSTARTC		
						Trigger output for synchronous stop C	T32A02SYNCSTOPOUTC	Synchronous stop at trigger input C	T32A03SYNCSTOPC
						Trigger output for synchronous reload C	T32A02SYNCRELOADOUTC	Synchronous reload at trigger input C	T32A03SYNCRELOADC

Table 2.78 T32A Synchronous control connection specification (2/2)

Master				Slave					
ch	Timer	Function (Output)	Signal name	ch	Timer	Function (input)	Signal name		
TA32 ch4	A	Trigger output for synchronous start A	T32A04SYNCSTARTOUTA	ch4	B	Synchronous start at trigger input B	T32A04SYNCSTARTB		
				ch5	A	Synchronous start at trigger input A	T32A05SYNCSTARTA		
		B	Synchronous start at trigger input B		T32A05SYNCSTARTB				
		Trigger output for synchronous stop A	T32A04SYNCSTOPOUTA	ch4	B	Synchronous stop at trigger input B	T32A04SYNCSTOPB		
				ch5	A	Synchronous stop at trigger input A	T32A05SYNCSTOPA		
		B	Synchronous stop at trigger input B		T32A05SYNCSTOPB				
	Trigger output for synchronous reload A	T32A04SYNCRELOADOUTA	ch4	B	Synchronous reload at trigger input B	T32A04SYNCRELOADB			
			ch5	A	Synchronous reload at trigger input A	T32A05SYNCRELOADA			
	B	Synchronous reload at trigger input B		T32A05SYNCRELOADB					
	C	Trigger output for synchronous start C	T32A04SYNCSTARTOUTC	ch5	C	Synchronous start at trigger input C	T32A05SYNCSTARTC		
						Trigger output for synchronous stop C	T32A04SYNCSTOPOUTC	Synchronous stop at trigger input C	T32A05SYNCSTOPC
						Trigger output for synchronous reload C	T32A04SYNCRELOADOUTC	Synchronous reload at trigger input C	T32A05SYNCRELOADC
TA32 ch6	A	Trigger output for synchronous start A	T32A06SYNCSTARTOUTA	ch6	B	Synchronous start at trigger input B	T32A06SYNCSTARTB		
				ch7	A	Synchronous start at trigger input A	T32A07SYNCSTARTA		
		B	Synchronous start at trigger input B		T32A07SYNCSTARTB				
		Trigger output for synchronous stop A	T32A06SYNCSTOPOUTA	ch6	B	Synchronous stop at trigger input B	T32A06SYNCSTOPB		
				ch7	A	Synchronous stop at trigger input A	T32A07SYNCSTOPA		
		B	Synchronous stop at trigger input B		T32A07SYNCSTOPB				
	Trigger output for synchronous reload A	T32A06SYNCRELOADOUTA	ch6	B	Synchronous reload at trigger input B	T32A06SYNCRELOADB			
			ch7	A	Synchronous reload at trigger input A	T32A07SYNCRELOADA			
	B	Synchronous reload at trigger input B		T32A07SYNCRELOADB					
	C	Trigger output for synchronous start C	T32A06SYNCSTARTOUTC	ch7	C	Synchronous start at trigger input C	T32A07SYNCSTARTC		
						Trigger output for synchronous stop C	T32A06SYNCSTOPOUTC	Synchronous stop at trigger input C	T32A07SYNCSTOPC
						Trigger output for synchronous reload C	T32A06SYNCRELOADOUTC	Synchronous reload at trigger input C	T32A07SYNCRELOADC

2.14.5. Pulse count correspondence classified by product List

As the pulse count specification of a 32-bit Timer Event Counter is shown in the following table, correspondence changes with products.

Table 2.79 T32A Pulse count support list

ch	M3HQ	M3HP	M3HN	M3HM	M3HL
T32A ch0			2-phase pulse count 1-phase pulse count		
T32A ch1			2-phase pulse count 1-phase pulse count		
T32A ch2		2-phase pulse count 1-phase pulse count			1-phase pulse count (T32A02INC0 only)
T32A ch3			2-phase pulse count 1-phase pulse count		
T32A ch4			2-phase pulse count 1-phase pulse count		
T32A ch5			2-phase pulse count 1-phase pulse count		
T32A ch6	2-phase pulse count 1-phase pulse count		1-phase pulse count (T32A06INC0 only)	-	-
T32A ch7	2-phase pulse count 1-phase pulse count		-	-	-

2.14.6. DMA request

The 32-bit Timer Event Counter has the DMA request shown in the following tables.

When there is mention of the register name in the trigger selector column of the table, please select a request to use with a trigger selector.

Table 2.80 T32A DMA request (1/3)

ch	Request	Signal name	Trigger selector (Note2)	DMA request channel			
				ch	unit	Single transmission	Burst transmission
T32A ch0	T32A ch0 DMA request at match A1 register	T32A00DMAREQCPA1	[TSEL0CR0] <INSEL0[2:0]>	15	A	-	✓
	T32A ch0 DMA request at match C1 register	T32A00DMAREQCMPC1					
	T32A ch0 DMA request at match B1 register	T32A00DMAREQCMPB1	[TSEL0CR0] <INSEL2[2:0]>	17	A	-	✓
	T32A ch0 DMA request at capture A0 register	T32A00DMAREQCAPA0	[TSEL0CR1] <INSEL4[2:0]>	19	A	-	✓
	T32A ch0 DMA request at capture A1 register	T32A00DMAREQCAPA1					
	T32A ch0 DMA request at capture C0 register	T32A00DMAREQCAPC0					
	T32A ch0 DMA request at capture C1 register	T32A00DMAREQCAPC1					
	T32A ch0 DMA request at capture B0 register	T32A00DMAREQCAPB0	[TSEL0CR1] <INSEL6[2:0]>	21	A	-	✓
	T32A ch0 DMA request at capture B1 register	T32A00DMAREQCAPB1					
T32A ch1	T32A ch1 DMA request at match A1 register	T32A01DMAREQCPA1	[TSEL0CR0] <INSEL0[2:0]>	15	A	-	✓
	T32A ch1 DMA request at match C1 register	T32A01DMAREQCMPC1					
	T32A ch1 DMA request at match B1 register	T32A01DMAREQCMPB1	[TSEL0CR0] <INSEL2[2:0]>	17	A	-	✓
	T32A ch1 DMA request at capture A0 register	T32A01DMAREQCAPA0	[TSEL0CR1] <INSEL4[2:0]>	19	A	-	✓
	T32A ch1 DMA request at capture A1 register	T32A01DMAREQCAPA1					
	T32A ch1 DMA request at capture C0 register	T32A01DMAREQCAPC0					
	T32A ch1 DMA request at capture C1 register	T32A01DMAREQCAPC1					
	T32A ch1 DMA request at capture B0 register	T32A01DMAREQCAPB0	[TSEL0CR1] <INSEL6[2:0]>	21	A	-	✓
	T32A ch1 DMA request at capture B1 register	T32A01DMAREQCAPB1					

Note1: ✓: Available, -: N/A

Note2: The trigger source of the start trigger is selected by [TSEL0CRn]<INSELM[2:0]>. For details of the connected destination, refer to "2.2. Trigger Selector (TRGSEL)".

Table 2.81 T32A DMA request (2/3)

ch	Request	Signal name	Trigger selector (Note2)	DMA request channel			
				ch	unit	Singlet transmission	Burst transmission
T32A ch2	T32A ch2 DMA request at match A1 register	T32A02DMAREQCMPA1	[TSEL0CR0] <INSEL1[2:0]>	16	A	-	✓
	T32A ch2 DMA request at match C1 register	T32A02DMAREQCMPC1					
	T32A ch2 DMA request at match B1 register	T32A02DMAREQCMPB1	[TSEL0CR0] <INSEL3[2:0]>	18	A	-	✓
	T32A ch2 DMA request at capture A0 register	T32A02DMAREQCAPA0	[TSEL0CR1] <INSEL5[2:0]>	20	A	-	✓
	T32A ch2 DMA request at capture A1 register	T32A02DMAREQCAPA1					
	T32A ch2 DMA request at capture C0 register	T32A02DMAREQCAPC0					
	T32A ch2 DMA request at capture C1 register	T32A02DMAREQCAPC1					
	T32A ch2 DMA request at capture B0 register	T32A02DMAREQCAPB0	[TSEL0CR1] <INSEL7[2:0]>	22	A	-	✓
T32A ch2 DMA request at capture B1 register	T32A02DMAREQCAPB1						
T32A ch3	T32A ch3 DMA request at match A1 register	T32A03DMAREQCMPA1	[TSEL0CR0] <INSEL1[2:0]>	16	A	-	✓
	T32A ch3 DMA request at match C1 register	T32A03DMAREQCMPC1					
	T32A ch3 DMA request at match B1 register	T32A03DMAREQCMPB1	[TSEL0CR0] <INSEL3[2:0]>	18	A	-	✓
	T32A ch3 DMA request at capture A0 register	T32A03DMAREQCAPA0	[TSEL0CR1] <INSEL5[2:0]>	20	A	-	✓
	T32A ch3 DMA request at capture A1 register	T32A03DMAREQCAPA1					
	T32A ch3 DMA request at capture C0 register	T32A03DMAREQCAPC0					
	T32A ch3 DMA request at capture C1 register	T32A03DMAREQCAPC1					
	T32A ch3 DMA request at capture B0 register	T32A03DMAREQCAPB0	[TSEL0CR1] <INSEL7[2:0]>	22	A	-	✓
T32A ch3 DMA request at capture B1 register	T32A03DMAREQCAPB1						
T32A ch4	T32A ch4 DMA request at match A1 register	T32A04DMAREQCMPA1	[TSEL0CR5] <INSEL20[2:0]>	15	B	-	✓
	T32A ch4 DMA request at match C1 register	T32A04DMAREQCMPC1					
	T32A ch4 DMA request at match B1 register	T32A04DMAREQCMPB1	[TSEL0CR5] <INSEL22[2:0]>	17	B	-	✓
	T32A ch4 DMA request at capture A0 register	T32A04DMAREQCAPA0	[TSEL0CR6] <INSEL24[2:0]>	19	B	-	✓
	T32A ch4 DMA request at capture A1 register	T32A04DMAREQCAPA1					
	T32A ch4 DMA request at capture C0 register	T32A04DMAREQCAPC0					
	T32A ch4 DMA request at capture C1 register	T32A04DMAREQCAPC1					
	T32A ch4 DMA request at capture B0 register	T32A04DMAREQCAPB0	[TSEL0CR6] <INSEL26[2:0]>	21	B	-	✓
T32A ch4 DMA request at capture B1 register	T32A04DMAREQCAPB1						

Note1: ✓: Available, -: N/A

Note2: The trigger source of the start trigger is selected by [TSEL0CRn]<INSELM[2:0]>. For details of the connected destination, refer to "2.2. Trigger Selector (TRGSEL)".

Table 2.82 T32A DMA request (3/3)

ch	Request	Signal name	Trigger selector (Note2)	DMA request channel			
				ch	unit	Single transmission	Burst transmission
T32A ch5	T32A ch5 DMA request at match A1 register	T32A05DMAREQCMPA1	[TSEL0CR5] <INSEL20[2:0]>	15	B	-	✓
	T32A ch5 DMA request at match C1 register	T32A05DMAREQCMPA1					
	T32A ch5 DMA request at match B1 register	T32A05DMAREQCMPB1	[TSEL0CR5] <INSEL22[2:0]>	17	B	-	✓
	T32A ch5 DMA request at capture A0 register	T32A05DMAREQCAPA0	[TSEL0CR6] <INSEL24[2:0]>	19	B	-	✓
	T32A ch5 DMA request at capture A1 register	T32A05DMAREQCAPA1					
	T32A ch5 DMA request at capture C0 register	T32A05DMAREQCAPC0					
	T32A ch5 DMA request at capture C1 register	T32A05DMAREQCAPC1					
	T32A ch5 DMA request at capture B0 register	T32A05DMAREQCAPB0	[TSEL0CR6] <INSEL26[2:0]>	21	B	-	✓
	T32A ch5 DMA request at capture B1 register	T32A05DMAREQCAPB1					
T32A ch6	T32A ch6 DMA request at match A1 register	T32A06DMAREQCMPA1	[TSEL0CR5] <INSEL21[2:0]>	16	B	-	✓
	T32A ch6 DMA request at match C1 register	T32A06DMAREQCMPA1					
	T32A ch6 DMA request at match B1 register	T32A06DMAREQCMPB1	[TSEL0CR5] <INSEL23[2:0]>	18	B	-	✓
	T32A ch6 DMA request at capture A0 register	T32A06DMAREQCAPA0	[TSEL0CR6] <INSEL25[2:0]>	20	B	-	✓
	T32A ch6 DMA request at capture A1 register	T32A06DMAREQCAPA1					
	T32A ch6 DMA request at capture C0 register	T32A06DMAREQCAPC0					
	T32A ch6 DMA request at capture C1 register	T32A06DMAREQCAPC1					
	T32A ch6 DMA request at capture B0 register	T32A06DMAREQCAPB0	[TSEL0CR6] <INSEL27[2:0]>	22	B	-	✓
	T32A ch6 DMA request at capture B1 register	T32A06DMAREQCAPB1					
T32A ch7	T32A ch7 DMA request at match A1 register	T32A07DMAREQCMPA1	[TSEL0CR5] <INSEL21[2:0]>	16	B	-	✓
	T32A ch7 DMA request at match C1 register	T32A07DMAREQCMPA1					
	T32A ch7 DMA request at match B1 register	T32A07DMAREQCMPB1	[TSEL0CR5] <INSEL23[2:0]>	18	B	-	✓
	T32A ch7 DMA request at capture A0 register	T32A07DMAREQCAPA0	[TSEL0CR6] <INSEL25[2:0]>	20	B	-	✓
	T32A ch7 DMA request at capture A1 register	T32A07DMAREQCAPA1					
	T32A ch7 DMA request at capture C0 register	T32A07DMAREQCAPC0					
	T32A ch7 DMA request at capture C1 register	T32A07DMAREQCAPC1					
	T32A ch7 DMA request at capture B0 register	T32A07DMAREQCAPB0	[TSEL0CR6] <INSEL27[2:0]>	22	B	-	✓
	T32A ch7 DMA request at capture B1 register	T32A07DMAREQCAPB1					

Note1: ✓: Available, -: N/A

Note2: The trigger source of the start trigger is selected by [TSEL0CRn]<INSELM[2:0]>. For details of the connected destination, refer to "2.2. Trigger Selector (TRGSEL)".

2.14.7. Non corresponding interrupt

Every count interrupt (INTT32AxEVRYC) does not correspond in the TPM3H Group(2).

2.15. Real Time Clock (RTC)

2.15.1. Built-in channel

The built-in channel for each product is shown in the following table.

Table 2.83 RTC Built-in List

Product	Built-in RTC (✓: Available, -: N/A)
M3HQ	✓
M3HP	✓
M3HN	✓
M3HM	✓
M3HL	✓

2.15.2. Functional pin and port

The functional terminal is assigned to the following ports.

Table 2.84 RTC Functional pin and a port

Functional pin (Signal name)		Port	Product table (✓: Available, -: N/A)				
			M3HQ	M3HP	M3HN	M3HM	M3HL
RTCOUT	Output	PC2	✓	✓	✓	✓	-

Note: TPM3H Group(2) does not have an ALARM_N pin.

2.15.3. RTC count clock

Real Time Clock uses the clock shown in the following table for count clock.

Table 2.85 RTC Count clock

Clock
fs

2.16. Asynchronous Serial Communication Circuit (UART)

2.16.1. Built-in channel

The built-in channel for every product is shown in the following table.

The maximum communication speed of UART in TMPM3H Group(2) is 2.5 Mbps.

Table 2.86 UART Built-in channel

Product	UART Built-in channel (✓: Available, -: N/A)							
	ch0	ch1	ch2	ch3	ch4	ch5	ch6	ch7
M3HQ	✓	✓	✓	✓	✓	✓	✓	✓
M3HP	✓	✓	✓	✓	✓	✓	✓	✓
M3HN	✓	✓	✓	✓	✓	✓	✓	✓
M3HM	✓	✓	✓	✓	✓	✓	✓	-
M3HL	✓	✓	✓	✓	✓	✓	✓	-

2.16.2. Functional pin and port

The functional pin is assigned to the port of the following table.

Please use exclusively the same functional pin currently assigned to plurality.

There is also a channel which does not have a functional pin by a product.

Table 2.87 UART Functional pin signal and a port (1/2)

ch	Functional pin (Signal name)		Port	Product table (✓: Available, -: N/A)				
				M3HQ	M3HP	M3HN	M3HM	M3HL
UART ch0	UT0TXDA	Output	PA1/PA2/PM1/PM2	✓/✓/✓/✓	✓/✓/✓/✓	✓/✓/✓/✓	✓/✓/✓/✓	✓/✓/✓/✓
	UT0TXDB	Output	PA0/PM0	✓/✓	✓/✓	✓/✓	✓/✓	✓/✓
	UT0RXD	Input	PA2/PA1/PM2/PM1	✓/✓/✓/✓	✓/✓/✓/✓	✓/✓/✓/✓	✓/✓/✓/✓	✓/✓/✓/✓
	UT0CTS_N	Input	PM3/PM4	✓/✓	✓/✓	✓/✓	-/-	-/-
	UT0RTS_N	Output	PM4/PM3	✓/✓	✓/✓	✓/✓	-/-	-/-
UART ch1	UT1TXDA	Output	PJ1/PJ2/PK1/PK2	✓/✓/✓/✓	✓/✓/✓/✓	✓/✓/✓/✓	✓/✓/✓/✓	✓/✓/✓/✓
	UT1TXDB	Output	PJ0/PK0	✓/✓	✓/✓	✓/✓	✓/✓	✓/✓
	UT1RXD	Input	PJ2/PJ1/PK2/PK1	✓/✓/✓/✓	✓/✓/✓/✓	✓/✓/✓/✓	✓/✓/✓/✓	✓/✓/✓/✓
	UT1CTS_N	Input	PJ3/PJ4/PK3/PK4	✓/✓/✓/✓	✓/✓/✓/✓	✓/✓/✓/✓	✓/✓/✓/✓	✓/✓/✓/✓
	UT1RTS_N	Output	PJ4/PJ3/PK4/PK3	✓/✓/✓/✓	✓/✓/✓/✓	✓/✓/✓/✓	✓/✓/✓/✓	✓/✓/✓/✓
UART ch2	UT2TXDA	Output	PB2/PB3/PL0/PL1	✓/✓/✓/✓	✓/✓/✓/✓	✓/✓/✓/✓	✓/✓/✓/✓	✓/✓/✓/✓
	UT2TXDB	Output	-	-	-	-	-	-
	UT2RXD	Input	PB3/PB2/PL1/PL0	✓/✓/✓/✓	✓/✓/✓/✓	✓/✓/✓/✓	✓/✓/✓/✓	✓/✓/✓/✓
	UT2CTS_N	Input	PB4/PB5/PL2/PL3	✓/✓/✓/✓	✓/✓/✓/✓	✓/✓/✓/✓	✓/✓/✓/✓	✓/✓/✓/✓
	UT2RTS_N	Output	PB5/PB4/PL3/PL2	✓/✓/✓/✓	✓/✓/✓/✓	✓/✓/✓/✓	✓/✓/✓/✓	✓/✓/✓/✓
UART ch3	UT3TXDA	Output	PA7/PA6/PG3/PG2	✓/✓/✓/✓	✓/✓/✓/✓	✓/✓/✓/✓	✓/✓/✓/✓	✓/✓/✓/✓
	UT3TXDB	Output	PG4	✓	✓	-	-	-
	UT3RXD	Input	PA6/PA7/PG2/PG3	✓/✓/✓/✓	✓/✓/✓/✓	✓/✓/✓/✓	✓/✓/✓/✓	✓/✓/✓/✓
	UT3CTS_N	Input	-	-	-	-	-	-
	UT3RTS_N	Output	-	-	-	-	-	-
UART ch4	UT4TXDA	Output	PC3/PC4/PV6/PV7	✓/✓/✓/✓	✓/✓/✓/✓	✓/✓/✓/✓	✓/✓/✓/✓	✓/✓/✓/✓
	UT4TXDB	Output	PC2/PV5	✓/✓	✓/✓	✓/✓	✓/✓	✓/✓
	UT4RXD	Input	PC4/PC3/PV7/PV6	✓/✓/✓/✓	✓/✓/✓/✓	✓/✓/✓/✓	✓/✓/✓/✓	✓/✓/✓/✓
	UT4CTS_N	Input	PC5/PC6	✓/✓	✓/✓	✓/✓	✓/✓	✓/✓
	UT4RTS_N	Output	PC6/PC5	✓/✓	✓/✓	✓/✓	✓/✓	✓/✓
UART ch5	UT5TXDA	Output	PN3/PN2	✓/✓	✓/✓	✓/✓	✓/✓	✓/✓
	UT5TXDB	Output	PN4	✓	✓	✓	✓	✓
	UT5RXD	Input	PN2/PN3	✓/✓	✓/✓	✓/✓	✓/✓	✓/✓
	UT5CTS_N	Input	PN1/PN0	✓/✓	✓/✓	✓/✓	✓/✓	✓/✓
	UT5RTS_N	Output	PN0/PN1	✓/✓	✓/✓	✓/✓	✓/✓	✓/✓

Table 2.88 UART Functional pin signal and a port (2/2)

ch	Functional pin (Signal name)		Port	Product table (✓: Available, -: N/A)				
				M3HQ	M3HP	M3HN	M3HM	M3HL
UART ch6	UT6TXDA	Output	PK6/PK5	✓/✓	✓/✓	✓/✓	✓/✓	✓/✓
	UT6TXDB	Output	PK7	✓	✓	✓	✓	—
	UT6RXD	Input	PK5/PK6	✓/✓	✓/✓	✓/✓	✓/✓	✓/✓
	UT6CTS_N	Input	-	-	-	-	-	-
	UT6RTS_N	Output	-	-	-	-	-	-
UART ch7	UT7TXDA	Output	PR1/PR0	✓/✓	✓/✓	✓/✓	-	-
	UT7TXDB	Output	PR2	✓	✓	✓	-	-
	UT7RXD	Input	PR0/PR1	✓/✓	✓/✓	✓/✓	-	-
	UT7CTS_N	Input	-	-	-	-	-	-
	UT7RTS_N	Output	-	-	-	-	-	-

2.16.3. Half clock mode list for each product

The asynchronous serial communication circuit has no half clock mode depending on the product as shown in the table below.

Table 2.89 UART Half clock mode adaptive list

Channel	Product table (✓: Available, -: N/A)				
	M3HQ	M3HP	M3HN	M3HM	M3HL
UART ch0	✓	✓	✓	✓	✓
UART ch1	✓	✓	✓	✓	✓
UART ch2	-	-	-	-	-
UART ch3	✓	✓	-	-	-
UART ch4	✓	✓	✓	✓	-
UART ch5	✓	✓	✓	✓	✓
UART ch6	✓	✓	✓	✓	-
UART ch7	✓	✓	✓	-	-

2.16.4. Clock for prescaler

Asynchronous serial communication circuit uses the clock shown in the following table for prescaler.

Table 2.90 UART Clock for prescaler

Clock
ΦT0

2.16.5. DMA request

An asynchronous serial communication circuit has the DMA request shown in the following table.

"-" in a table does not have an applicable function.

Table 2.91 UART DMA request

ch	Request	Signal name	Trigger selector	DMA request channel			
				ch	Unit	Single transmission	Burst transmission
UART ch0	UART ch0 reception DMA request	UART0RX_DMAREQ	-	6	A	✓	✓
	UART ch0 transmission DMA request	UART0TX_DMAREQ		7	A	✓	✓
UART ch1	UART ch1 reception DMA request	UART1RX_DMAREQ	-	8	A	✓	✓
	UART ch1 transmission DMA request	UART1TX_DMAREQ		9	A	✓	✓
UART ch2	UART ch2 reception DMA request	UART2RX_DMAREQ	-	10	A	✓	✓
	UART ch2 transmission DMA request	UART2TX_DMAREQ		11	A	✓	✓
UART ch3	UART ch3 reception DMA request	UART3RX_DMAREQ	-	12	A	✓	✓
	UART ch3 transmission DMA request	UART3TX_DMAREQ		13	A	✓	✓
UART ch4	UART ch4 reception DMA request	UART4RX_DMAREQ	-	10	B	✓	✓
	UART ch4 transmission DMA request	UART4TX_DMAREQ		11	B	✓	✓
UART ch5	UART ch5 reception DMA request	UART5RX_DMAREQ	-	12	B	✓	✓
	UART ch5 transmission DMA request	UART5TX_DMAREQ		13	B	✓	✓
UART ch6	UART ch6 reception DMA request	UART6RX_DMAREQ	-	17	B	✓	✓
	UART ch6 transmission DMA request	UART6TX_DMAREQ		18	B	✓	✓
UART ch7	UART ch7 reception DMA request	UART7RX_DMAREQ	-	21	B	✓	✓
	UART ch7 transmission DMA request	UART7TX_DMAREQ		22	B	✓	✓

Note1: ✓: Available, -: N/A

Note2: There is no UART ch7 in M3HM and M3HL.

2.16.6. Internal signal connection specification

2.16.6.1. Trigger transmission signal connection specification

An asynchronous serial communication circuit has a transmitting function by a trigger signal.

A trigger signal selects and uses the trigger source shown in the following table by a trigger selector.

Table 2.92 UART Trigger transmission signal connection specification (1/2)

ch	Signal name	Trigger selector (Note)	Trigger source	
			Input trigger signal	Signal name
UART ch0	UART0TRGIN (Input)	[TSEL0CR11] <INSEL44[2:0]>	PB1 pin	TRGIN0
			PA3 pin	TRGIN1
			PN3 pin	TRGIN2
			T32A ch6 timer register A1 match trigger	T32A06TRGOUTCMPA1
			T32A ch6 timer register B1 match trigger	T32A06TRGOUTCMPB1
			T32A ch6 timer register C1 match trigger	T32A06TRGOUTCMPC1
UART ch1	UART1TRGIN (Input)	[TSEL0CR11] <INSEL45[2:0]>	PB1 pin	TRGIN0
			PA3 pin	TRGIN1
			PN3 pin	TRGIN2
			T32A ch6 timer register A1 match trigger	T32A06TRGOUTCMPA1
			T32A ch6 timer register B1 match trigger	T32A06TRGOUTCMPB1
			T32A ch6 timer register C1 match trigger	T32A06TRGOUTCMPC1
UART ch2	UART2TRGIN (Input)	[TSEL0CR11] <INSEL46[2:0]>	PB1 pin	TRGIN0
			PA3 pin	TRGIN1
			PN3 pin	TRGIN2
			T32A ch6 timer register A1 match trigger	T32A06TRGOUTCMPA1
			T32A ch6 timer register B1 match trigger	T32A06TRGOUTCMPB1
			T32A ch6 timer register C1 match trigger	T32A06TRGOUTCMPC1
UART ch3	UART3TRGIN (Input)	[TSEL0CR11] <INSEL47[2:0]>	PB1 pin	TRGIN0
			PA3 pin	TRGIN1
			PN3 pin	TRGIN2
			T32A ch6 timer register A1 match trigger	T32A06TRGOUTCMPA1
			T32A ch6 timer register B1 match trigger	T32A06TRGOUTCMPB1
			T32A ch6 timer register C1 match trigger	T32A06TRGOUTCMPC1
UART ch4	UART4TRGIN (Input)	[TSEL0CR12] <INSEL48[2:0]>	PB1 pin	TRGIN0
			PA3 pin	TRGIN1
			PN3 pin	TRGIN2
			T32A ch6 timer register A1 match trigger	T32A06TRGOUTCMPA1
			T32A ch6 timer register B1 match trigger	T32A06TRGOUTCMPB1
			T32A ch6 timer register C1 match trigger	T32A06TRGOUTCMPC1
UART ch5	UART5TRGIN (Input)	[TSEL0CR12] <INSEL49[2:0]>	PB1 pin	TRGIN0
			PA3 pin	TRGIN1
			PN3 pin	TRGIN2
			T32A ch6 timer register A1 match trigger	T32A06TRGOUTCMPA1
			T32A ch6 timer register B1 match trigger	T32A06TRGOUTCMPB1
			T32A ch6 timer register C1 match trigger	T32A06TRGOUTCMPC1

Note: The trigger source of the start trigger is selected by [TSEL0CRn]<INSELM[2:0]>. For details of trigger selector, refer to "2.2. Trigger Selector (TRGSEL)".

Table 2.93 UART Trigger transmission signal connection specification (2/2)

ch	Signal name	Trigger source		
		Trigger selector (Note1)	Input trigger signal	Signal name
UART ch6	UART6TRGIN (Input)	[TSEL1CR2] <INSEL10[2:0]> (<INSEL74[2:0]>)	PB1 pin	TRGIN0
			PA3 pin	TRGIN1
			PN3 pin	TRGIN2
			T32A ch6 timer register A1 match trigger	T32A06TRGOUTCMPA1
			T32A ch6 timer register B1 match trigger	T32A06TRGOUTCMPB1
			T32A ch6 timer register C1 match trigger	T32A06TRGOUTCMPC1
UART ch7 (Note2)	UART7TRGIN (Input)	[TSEL1CR2] <INSEL11[2:0]> (<INSEL75[2:0]>)	PB1 pin	TRGIN0
			PA3 pin	TRGIN1
			PN3 pin	TRGIN2
			T32A ch6 timer register A1 match trigger	T32A06TRGOUTCMPA1
			T32A ch6 timer register B1 match trigger	T32A06TRGOUTCMPB1
			T32A ch6 timer register C1 match trigger	T32A06TRGOUTCMPC1

Note1: The trigger source of the start trigger is selected by **[TSEL1CRn]**<INSELM[2:0]>. For details of trigger selector, refer to "2.2. Trigger Selector (TRGSEL)".

Note2: There is no UART ch7 in M3HM and M3HL.

2.16.6.2. T32A connection

In addition to this, the asynchronous serial communication circuit is connected with the peripheral function inside, as shown in the following table.

Table 2.94 UART Internal connection specification: Output

Input/output	Functional output	Signal name	Trigger selector (Note1)		Peripheral function	Destination	Signal name																																																																										
Output	UART ch0 Transmission completion trigger	UART0TXTRG	[TSEL0CR12]	[TSEL1CR3]	T32A	Timer A ch0	T32A00TRGINAPCK																																																																										
	UART ch0 Reception completion trigger	UART0RXTRG	<INSEL50[2:0]>	<INSEL76[2:0]>				UART ch1 Transmission completion trigger	UART1TXTRG	[TSEL0CR13]	[TSEL1CR3]	T32A	Timer A ch1	T32A01TRGINAPCK	UART ch1 Reception completion trigger	UART1RXTRG	<INSEL53[2:0]>	<INSEL77[2:0]>	UART ch2 Transmission completion trigger	UART2TXTRG	[TSEL0CR14]	[TSEL1CR3]	T32A	Timer A ch2	T32A02TRGINAPCK	UART ch2 Reception completion trigger	UART2RXTRG	<INSEL56[2:0]>	<INSEL78[2:0]>	UART ch3 Transmission completion trigger	UART3TXTRG	[TSEL0CR14]	[TSEL1CR3]	T32A	Timer A ch3	T32A03TRGINAPCK	UART ch3 Reception completion trigger	UART3RXTRG	<INSEL59[2:0]>	<INSEL79[2:0]>	UART ch4 Transmission completion trigger	UART4TXTRG	[TSEL0CR15]	[TSEL1CR4]	T32A	Timer A ch4	T32A04TRGINAPCK	UART ch4 Reception completion trigger	UART4RXTRG	<INSEL62[2:0]>	<INSEL80[2:0]>	UART ch5 Transmission completion trigger	UART5TXTRG	[TSEL1CR0]	[TSEL1CR4]	T32A	Timer A ch5	T32A05TRGINAPCK	UART ch5 Reception completion trigger	UART5RXTRG	<INSEL65[2:0]>	<INSEL81[2:0]>	UART ch6 Transmission completion trigger	UART6TXTRG	[TSEL1CR4]	-	T32A	Timer A ch6	T32A06TRGINAPCK	UART ch6 Reception completion trigger	UART6RXTRG	<INSEL82[2:0]>		UART ch7 Transmission completion trigger (Note2)	UART7TXTRG	[TSEL1CR0]	-	T32A	Timer A ch7	T32A07TRGINAPCK	UART ch7 Reception completion trigger (Note2)
	UART ch1 Transmission completion trigger	UART1TXTRG	[TSEL0CR13]	[TSEL1CR3]	T32A	Timer A ch1	T32A01TRGINAPCK																																																																										
	UART ch1 Reception completion trigger	UART1RXTRG	<INSEL53[2:0]>	<INSEL77[2:0]>				UART ch2 Transmission completion trigger	UART2TXTRG	[TSEL0CR14]	[TSEL1CR3]	T32A	Timer A ch2	T32A02TRGINAPCK	UART ch2 Reception completion trigger	UART2RXTRG	<INSEL56[2:0]>	<INSEL78[2:0]>	UART ch3 Transmission completion trigger	UART3TXTRG	[TSEL0CR14]	[TSEL1CR3]	T32A	Timer A ch3	T32A03TRGINAPCK	UART ch3 Reception completion trigger	UART3RXTRG	<INSEL59[2:0]>	<INSEL79[2:0]>	UART ch4 Transmission completion trigger	UART4TXTRG	[TSEL0CR15]	[TSEL1CR4]	T32A	Timer A ch4	T32A04TRGINAPCK	UART ch4 Reception completion trigger	UART4RXTRG	<INSEL62[2:0]>	<INSEL80[2:0]>	UART ch5 Transmission completion trigger	UART5TXTRG	[TSEL1CR0]	[TSEL1CR4]	T32A	Timer A ch5	T32A05TRGINAPCK	UART ch5 Reception completion trigger	UART5RXTRG	<INSEL65[2:0]>	<INSEL81[2:0]>	UART ch6 Transmission completion trigger	UART6TXTRG	[TSEL1CR4]	-	T32A	Timer A ch6	T32A06TRGINAPCK	UART ch6 Reception completion trigger	UART6RXTRG	<INSEL82[2:0]>		UART ch7 Transmission completion trigger (Note2)	UART7TXTRG	[TSEL1CR0]	-	T32A	Timer A ch7	T32A07TRGINAPCK	UART ch7 Reception completion trigger (Note2)	UART7RXTRG	<INSEL83[2:0]>									
	UART ch2 Transmission completion trigger	UART2TXTRG	[TSEL0CR14]	[TSEL1CR3]	T32A	Timer A ch2	T32A02TRGINAPCK																																																																										
	UART ch2 Reception completion trigger	UART2RXTRG	<INSEL56[2:0]>	<INSEL78[2:0]>				UART ch3 Transmission completion trigger	UART3TXTRG	[TSEL0CR14]	[TSEL1CR3]	T32A	Timer A ch3	T32A03TRGINAPCK	UART ch3 Reception completion trigger	UART3RXTRG	<INSEL59[2:0]>	<INSEL79[2:0]>	UART ch4 Transmission completion trigger	UART4TXTRG	[TSEL0CR15]	[TSEL1CR4]	T32A	Timer A ch4	T32A04TRGINAPCK	UART ch4 Reception completion trigger	UART4RXTRG	<INSEL62[2:0]>	<INSEL80[2:0]>	UART ch5 Transmission completion trigger	UART5TXTRG	[TSEL1CR0]	[TSEL1CR4]	T32A	Timer A ch5	T32A05TRGINAPCK	UART ch5 Reception completion trigger	UART5RXTRG	<INSEL65[2:0]>	<INSEL81[2:0]>	UART ch6 Transmission completion trigger	UART6TXTRG	[TSEL1CR4]	-	T32A	Timer A ch6	T32A06TRGINAPCK	UART ch6 Reception completion trigger	UART6RXTRG	<INSEL82[2:0]>		UART ch7 Transmission completion trigger (Note2)	UART7TXTRG	[TSEL1CR0]	-	T32A	Timer A ch7	T32A07TRGINAPCK	UART ch7 Reception completion trigger (Note2)	UART7RXTRG	<INSEL83[2:0]>																				
	UART ch3 Transmission completion trigger	UART3TXTRG	[TSEL0CR14]	[TSEL1CR3]	T32A	Timer A ch3	T32A03TRGINAPCK																																																																										
	UART ch3 Reception completion trigger	UART3RXTRG	<INSEL59[2:0]>	<INSEL79[2:0]>				UART ch4 Transmission completion trigger	UART4TXTRG	[TSEL0CR15]	[TSEL1CR4]	T32A	Timer A ch4	T32A04TRGINAPCK	UART ch4 Reception completion trigger	UART4RXTRG	<INSEL62[2:0]>	<INSEL80[2:0]>	UART ch5 Transmission completion trigger	UART5TXTRG	[TSEL1CR0]	[TSEL1CR4]	T32A	Timer A ch5	T32A05TRGINAPCK	UART ch5 Reception completion trigger	UART5RXTRG	<INSEL65[2:0]>	<INSEL81[2:0]>	UART ch6 Transmission completion trigger	UART6TXTRG	[TSEL1CR4]	-	T32A	Timer A ch6	T32A06TRGINAPCK	UART ch6 Reception completion trigger	UART6RXTRG	<INSEL82[2:0]>		UART ch7 Transmission completion trigger (Note2)	UART7TXTRG	[TSEL1CR0]	-	T32A	Timer A ch7	T32A07TRGINAPCK	UART ch7 Reception completion trigger (Note2)	UART7RXTRG	<INSEL83[2:0]>																															
	UART ch4 Transmission completion trigger	UART4TXTRG	[TSEL0CR15]	[TSEL1CR4]	T32A	Timer A ch4	T32A04TRGINAPCK																																																																										
	UART ch4 Reception completion trigger	UART4RXTRG	<INSEL62[2:0]>	<INSEL80[2:0]>				UART ch5 Transmission completion trigger	UART5TXTRG	[TSEL1CR0]	[TSEL1CR4]	T32A	Timer A ch5	T32A05TRGINAPCK	UART ch5 Reception completion trigger	UART5RXTRG	<INSEL65[2:0]>	<INSEL81[2:0]>	UART ch6 Transmission completion trigger	UART6TXTRG	[TSEL1CR4]	-	T32A	Timer A ch6	T32A06TRGINAPCK	UART ch6 Reception completion trigger	UART6RXTRG	<INSEL82[2:0]>		UART ch7 Transmission completion trigger (Note2)	UART7TXTRG	[TSEL1CR0]	-	T32A	Timer A ch7	T32A07TRGINAPCK	UART ch7 Reception completion trigger (Note2)	UART7RXTRG	<INSEL83[2:0]>																																										
	UART ch5 Transmission completion trigger	UART5TXTRG	[TSEL1CR0]	[TSEL1CR4]	T32A	Timer A ch5	T32A05TRGINAPCK																																																																										
	UART ch5 Reception completion trigger	UART5RXTRG	<INSEL65[2:0]>	<INSEL81[2:0]>				UART ch6 Transmission completion trigger	UART6TXTRG	[TSEL1CR4]	-	T32A	Timer A ch6	T32A06TRGINAPCK	UART ch6 Reception completion trigger	UART6RXTRG	<INSEL82[2:0]>		UART ch7 Transmission completion trigger (Note2)	UART7TXTRG	[TSEL1CR0]	-	T32A	Timer A ch7	T32A07TRGINAPCK	UART ch7 Reception completion trigger (Note2)	UART7RXTRG	<INSEL83[2:0]>																																																					
	UART ch6 Transmission completion trigger	UART6TXTRG	[TSEL1CR4]	-	T32A	Timer A ch6	T32A06TRGINAPCK																																																																										
	UART ch6 Reception completion trigger	UART6RXTRG	<INSEL82[2:0]>					UART ch7 Transmission completion trigger (Note2)	UART7TXTRG	[TSEL1CR0]	-	T32A	Timer A ch7	T32A07TRGINAPCK	UART ch7 Reception completion trigger (Note2)	UART7RXTRG	<INSEL83[2:0]>																																																																
UART ch7 Transmission completion trigger (Note2)	UART7TXTRG	[TSEL1CR0]	-	T32A	Timer A ch7	T32A07TRGINAPCK																																																																											
UART ch7 Reception completion trigger (Note2)	UART7RXTRG	<INSEL83[2:0]>																																																																															

Note1: The trigger source of the start trigger is selected by [TSELxCRn]<INSELm[2:0]>. For details of trigger selector, refer to "2.2. Trigger Selector (TRGSEL)".

Note2: There is no UART ch7 in M3HM and M3HL.

2.17. I²C interface (I2C)

2.17.1. Built-in channel

The built-in channel for each product is shown in the following table.

The I²C interface (I2C) on the TMPM3H Group(2) products supports standard mode and fast mode.

Table 2.95 I²C interface Built-in channel

Product	I ² C Built-in channel (✓: Available, -: N/A)			
	ch0	ch1	ch2	ch3
M3HQ	✓	✓	✓	✓
M3HP	✓	✓	✓	✓
M3HN	✓	✓	✓	-
M3HM	✓	✓	✓	-
M3HL	✓	-	✓	-

2.17.2. Functional pin and port

The functional pin is assigned to the port of the following table.

Table 2.96 I²C interface Functional pin and port

ch	Functional pin (signal name)		Port	Product table (✓: Available, -: N/A)				
				M3HQ	M3HP	M3HN	M3HM	M3HL
I2C ch0	I2C0SCL	Input/output	PC0	✓	✓	✓	✓	✓
	I2C0SDA	Input/output	PC1	✓	✓	✓	✓	✓
I2C ch1	I2C1SCL	Input/output	PA4	✓	✓	✓	✓	-
	I2C1SDA	Input/output	PA5	✓	✓	✓	✓	-
I2C ch2	I2C2SCL	Input/output	PL0	✓	✓	✓	✓	✓
	I2C2SDA	Input/output	PL1	✓	✓	✓	✓	✓
I2C ch3	I2C3SCL	Input/output	PT1	✓	✓	-	-	-
	I2C3SDA	Input/output	PT0	✓	✓	-	-	-

2.17.3. Clock for prescaler

I²C interface uses the clock shown in the following table for prescaler.

Table 2.97 I²C interface Clock for prescaler

Clock

fsys

2.17.4. Address match wakeup function support

The address match wakeup function differs depending on the product as shown in the table below.

I²C interface supports 7-bit slave address mode.

Table 2.98 I²C interface Address match wakeup function (I2CS) adaptive list

ch	Product table (✓: Available, -: N/A)				
	M3HQ	M3HP	M3HN	M3HM	M3HL
I2C ch0	✓	✓	✓	✓	✓
I2C ch1	-	-	-	-	-
I2C ch2	-	-	-	-	-
I2C ch3	-	-	-	-	-

2.17.5. Noise filter

Noise filter built-in is shown in the table below. Address match wakeup function (I2CS) of channel 0 uses an analog noise filter.

Table 2.99 I²C interface Noise Filter

ch	Noise filter Type
I2C ch0	Digital
	I2CS Analog
I2C ch1	Digital
I2C ch2	Digital
I2C ch3	Digital

2.17.6. DMA request

The I²C interface has the DMA request shown in the following table.

Table 2.100 I²C interface DMA request

ch	Request	Signal name	Trigger selector	DMA request channel			
				ch	unit	Single Transmission	Burst Transmission
I2C ch0	I2C ch0 receiving DMA request	I2C0RXDMAREQ	-	4	A	-	✓
	I2C ch0 transmitting DMA request	I2C0TXDMAREQ		5	A	-	✓
I2C ch1 (Note2)	I2C ch1 receiving DMA request	I2C1RXDMAREQ	-	6	B	-	✓
	I2C ch1 transmitting DMA request	I2C1TXDMAREQ		7	B	-	✓
I2C ch2	I2C ch2 receiving DMA request	I2C2RXDMAREQ	-	8	B	-	✓
	I2C ch2 transmitting DMA request	I2C2TXDMAREQ		9	B	-	✓
I2C ch3 (Note3)	I2C ch3 receiving DMA request	I2C3RXDMAREQ	[TSEL0CR4] <INSEL17[2:0]> (Note1)	0	B	-	✓
	I2C ch3 transmitting DMA request	I2C3TXDMAREQ	[TSEL0CR4] <INSEL18[2:0]> (Note1)	1	B	-	✓

Note1: The trigger source of the start trigger is selected by [TSEL0CR4]<INSELm[2:0]>. For details of trigger selector, refer to "2.2. Trigger Selector (TRGSEL)".

Note2: There is not I2C ch1 in M3HL.

Note3: There is no I2C ch3 in M3HN, M3HM, and M3HL.

Note4: ✓: Available, -: N/A

2.18. I²C interface version A (EI2C)

2.18.1. Built-in channel

The built-in channel for each product is shown in the following table.

The I²C interface version A (EI2C) on the TMPM3H Group(2) products supports standard mode, fast mode, and fast mode plus.

Table 2.101 I²C interface version A Built-in channel

Product	I ² C interface version A Built-in channel (✓: Available, -: N/A)			
	ch0	ch1	ch2	ch3
M3HQ	✓	✓	✓	✓
M3HP	✓	✓	✓	✓
M3HN	✓	✓	✓	-
M3HM	✓	✓	✓	-
M3HL	✓	-	✓	-

2.18.2. Functional pin and port

The functional pin is assigned to the port of the following table.

Table 2.102 I²C interface version A Functional pin and port

ch	Functional pin (signal name)		Port	Product table (✓: Available, -: N/A)				
				M3HQ	M3HP	M3HN	M3HM	M3HL
EI2C ch0	EI2C0SCL	Input/output	PC0	✓	✓	✓	✓	✓
	EI2C0SDA	Input/output	PC1	✓	✓	✓	✓	✓
EI2C ch1	EI2C1SCL	Input/output	PA4	✓	✓	✓	✓	-
	EI2C1SDA	Input/output	PA5	✓	✓	✓	✓	-
EI2C ch2	EI2C2SCL	Input/output	PL0	✓	✓	✓	✓	✓
	EI2C2SDA	Input/output	PL1	✓	✓	✓	✓	✓
EI2C ch3	EI2C3SCL	Input/output	PT1	✓	✓	-	-	-
	EI2C3SDA	Input/output	PT0	✓	✓	-	-	-

2.18.3. Clock for prescaler

I²C interface version A uses the clock shown in the following table for prescaler.

Table 2.103 I²C interface version A Clock for prescaler

Clock
fsys

2.18.4. Address match wakeup function support (I2CS)

The address match wakeup function differs depending on the product as shown in the table below.

I²C interface version A (EI2C) supports 7/10-bit slave address mode.

Table 2.104 I²C interface version A Address match wakeup function (I2CS) adaptive list

ch	Product table (✓: Available, -: N/A)				
	M3HQ	M3HP	M3HN	M3HM	M3HL
EI2C ch0	✓	✓	✓	✓	✓
EI2C ch1	-	-	-	-	-
EI2C ch2	-	-	-	-	-
EI2C ch3	-	-	-	-	-

2.18.5. Noise filter

Noise filter built-in is shown in the table below. Channel 0 can use an analog filter. Address match wakeup function (I2CS) of channel 0 uses an analog noise filter.

Table 2.105 I²C interface version A Noise Filter

ch	Noise filter Type
EI2C ch0	Digital
	I2CS Analog
EI2C ch1	Digital
EI2C ch2	Digital
EI2C ch3	Digital

2.18.6. DMA request

The I²C interface version A (E2IC) has the DMA request shown in the following table.

Table 2.106 I²C interface version A DMA request

ch	Request	Signal name	Trigger selector	DMA request channel			
				ch	unit	Single transmission	Burst transmission
EI2C ch0	EI2C ch0 Receiving DMA request	I2C0ARXDMAREQ	-	4	A	-	✓
	EI2C ch0 Transmitting DMA request	I2C0ATXDMAREQ		5	A	-	✓
EI2C ch1 (Note2)	EI2C ch1 Receiving DMA request	I2C1ARXDMAREQ	-	6	B	-	✓
	EI2C ch1 Transmitting DMA request	I2C1ATXDMAREQ		7	B	-	✓
EI2C ch2	EI2C ch2 Receiving DMA request	I2C2ARXDMAREQ	-	8	B	-	✓
	EI2C ch2 Transmitting DMA request	I2C2ATXDMAREQ		9	B	-	✓
EI2C ch3 (Note3)	EI2C ch3 Receiving DMA request	I2C3ARXDMAREQ	[TSEL0CR4] <INSEL17[2:0]> (Note1)	0	B	-	✓
	EI2C ch3 Transmitting DMA request	I2C3ATXDMAREQ	[TSEL0CR4] <INSEL18[2:0]> (Note1)	1	B	-	✓

Note1: The trigger source of the start trigger is selected by [TSEL0CR4]<INSELM[2:0]>. For details of trigger selector, refer to "2.2. Trigger Selector (TRGSEL)".

Note2: There is not EI2C ch1 in M3HL.

Note3: There is no EI2C ch3 in M3HN, M3HM, and M3HL.

Note4: ✓: Available, -: N/A

2.19. Serial Peripheral Interface (TSPI)

2.19.1. Built-in channel

The built-in channel for each product is shown in the following table.

TMPM3H Group(2) Maximum transfer clock of TSPI is 20 MHz in master mode, 10MHz in slave mode. The maximum value varies depending on the channel, refer to the electrical characteristics of the datasheet.

Table 2.107 TSPI Built-in channel

Product	TSPI Built-in channel (✓: Available, -: N/A)				
	ch0	ch1	ch2	ch3	ch4
M3HQ	✓	✓	✓	✓	✓
M3HP	✓	✓	✓	✓	✓
M3HN	✓	✓	✓	✓	-
M3HM	✓	✓	✓	✓	-
M3HL	✓	-	-	-	-

2.19.2. Functional pin and port

The functional pin is assigned to the port below.

Please use exclusively the same functional pin currently assigned to plurality.

There is also a channel which does not have a functional pin by a product.

Table 2.108 TSPI Functional pin and a port

ch	Functional pin (signal name)		Port	Product table (✓: Available, -: N/A)				
				M3HQ	M3HP	M3HN	M3HM	M3HL
TSPI ch0	TSPI0SCK	Input/output	PA0/PM0	✓/✓	✓/✓	✓/✓	✓/✓	✓/✓
	TSPI0TXD	Output	PA1/PM1	✓/✓	✓/✓	✓/✓	✓/✓	✓/-
	TSPI0RXD	Input	PA2/PM2	✓/✓	✓/✓	✓/✓	✓/✓	✓/-
	TSPI0CSIN	Input	PA3/PM3	✓/✓	✓/✓	✓/✓	✓/-	✓/-
	TSPI0CS0	Output	PA3/PM3	✓/✓	✓/✓	✓/✓	✓/-	✓/-
	TSPI0CS1	Output	PA4/PM4	✓/✓	✓/✓	✓/✓	✓/-	-/-
TSPI ch1	TSPI1SCK	Input/output	PB2	✓	✓	✓	✓	-
	TSPI1TXD	Output	PB3	✓	✓	✓	✓	-
	TSPI1RXD	Input	PB4	✓	✓	✓	✓	-
	TSPI1CSIN	Input	PB5	✓	✓	✓	-	-
	TSPI1CS0	Output	PB5	✓	✓	✓	-	-
	TSPI1CS1	Output	PB6	✓	✓	✓	-	-
TSPI ch2	TSPI2SCK	Input/output	PP0/PT2	✓/✓	✓/✓	✓/-	✓/-	-/-
	TSPI2TXD	Output	PP1/PT3	✓/✓	✓/✓	✓/-	✓/-	-/-
	TSPI2RXD	Input	PP2/PT4	✓/✓	✓/-	✓/-	✓/-	-/-
	TSPI2CSIN	Input	PT1	✓	✓	-	-	-
	TSPI2CS0	Output	PT1	✓	✓	-	-	-
	TSPI2CS1	Output	PT0	✓	✓	-	-	-
TSPI ch3	TSPI3SCK	Input/output	PP5	✓	✓	✓	✓	-
	TSPI3TXD	Output	PP4	✓	✓	✓	✓	-
	TSPI3RXD	Input	PP3	✓	✓	✓	✓	-
	TSPI3CSIN	Input	PP6	✓	✓	✓	✓	-
	TSPI3CS0	Output	PP6	✓	✓	✓	✓	-
	TSPI3CS1	Output	PP7	✓	✓	✓	-	-
TSPI ch4	TSPI4SCK	Input/output	PH4	✓	✓	-	-	-
	TSPI4TXD	Output	PH5	✓	✓	-	-	-
	TSPI4RXD	Input	PH6	✓	✓	-	-	-

2.19.3. Transfer mode list for each product

The serial peripheral interface has different transfer modes that can be used depending on the product as shown in the following table.

Table 2.109 TSPI Mode support list

ch	Mode support				
	M3HQ	M3HP	M3HN	M3HM	M3HL
TSPI ch0	SPI mode SIO mode				
TSPI ch1	SPI mode SIO mode			SIO mode	-
TSPI ch2	SPI mode SIO mode		SIO mode		-
TSPI ch3	SPI mode SIO mode				-
TSPI ch4	SIO mode		-		

2.19.4. Setting Value of [TSPIxCR2]<RXDLY[2:0]>

Set the TSPI control register 2 ([TSPIxCR2]<RXDLY[2:0]>) according to the table below.

Table 2.110 Setting Value of TSPI control register2<RXDLY>

Register Name	Value	Operating Frequency (MHz)
[TSPIxCR2]<RXDLY[2:0]>	010	fsys > 80
	001	40 < fsys ≤ 80
	000	fsys ≤ 40

2.19.5. Clock for TSPI

Serial peripheral interface uses the clock shown in the following table.

Table 2.111 Clock for TSPI

Operation clock	Clock for prescaler
fsys	ΦT0

2.19.6. DMA request

A serial peripheral interface has the DMA request shown in the following table.

Table 2.112 TSPI DMA request

ch	Request	Signal name	Trigger selector	DMA request channel			
				ch	unit	Single Transmission	Burst Transmission
TSPI ch0	TSPI ch0 Receive DMA request	TSPI0RX_DMA	-	0	A	✓	✓
	TSPI ch0 Transmit DMA request	TSPI0TX_DMA		1	A	✓	✓
TSPI ch1 (Note2)	TSPI ch1 Receive DMA request	TSPI1RX_DMA	-	2	A	✓	✓
	TSPI ch1 Transmit DMA request	TSPI1TX_DMA		3	A	✓	✓
TSPI ch2 (Note2)	TSPI ch2 Receive DMA request	TSPI2RX_DMA	[TSELOCR4] <INSEL17[2:0]> (Note1)	0	B	✓	✓
	TSPI ch2 Transmit DMA request	TSPI2TX_DMA	[TSELOCR4] <INSEL18[2:0]> (Note1)	1	B	✓	✓
TSPI ch3 (Note2)	TSPI ch3 Receive DMA request	TSPI3RX_DMA	-	2	B	✓	✓
	TSPI ch3 Transmit DMA request	TSPI3TX_DMA		3	B	✓	✓
TSPI ch4 (Note3)	TSPI ch4 Receive DMA request	TSPI4RX_DMA	-	4	B	✓	✓
	TSPI ch4 Transmit DMA request	TSPI4TX_DMA		5	B	✓	✓

Note1: The trigger source of the start trigger is selected by [TSELOCR4]<INSELM[2:0]>. For details of trigger selector, refer to "2.2. Trigger Selector (TRGSEL)".

Note2: There is no TSPI ch1, ch2 and ch3 in M3HL.

Note3: There is no TSPI ch4 in M3HN, M3HM, and M3HL.

Note4: ✓: Available, -: N/A

2.19.7. Internal signal connection specification

A serial peripheral interface has a transmitting function by a trigger signal.

A trigger selector selects the trigger source shown in the following table. And it is uses as a trigger signal.

2.19.7.1. Trigger transmitting signal connection specification

Table 2.113 TSPI Trigger transmission specification

ch	Signal name	Trigger selector (Note1)	Trigger source	
			Input trigger signal	Signal name
TSPI ch0	TSPI0TRG (Input)	[TSEL0CR9] <INSEL39[2:0]>	PB1 pin	TRGIN0
			PA3 pin	TRGIN1
			PN3 pin	TRGIN2
			T32A ch6 timer register A1 match trigger	T32A06TRGOUTCMPA1
			T32A ch6 timer register B1 match trigger	T32A06TRGOUTCMPB1
			T32A ch6 timer register C1 match trigger	T32A06TRGOUTCMPC1
TSP ch1 (Note2)	TSPI1TRG (Input)	[TSEL0CR10] <INSEL40[2:0]>	PB1 pin	TRGIN0
			PA3 pin	TRGIN1
			PN3 pin	TRGIN2
			T32A ch6 timer register A1 match trigger	T32A06TRGOUTCMPA1
			T32A ch6 timer register B1 match trigger	T32A06TRGOUTCMPB1
			T32A ch6 timer register C1 match trigger	T32A06TRGOUTCMPC1
TSPI ch2 (Note2)	TSPI2TRG (Input)	[TSEL0CR10] <INSEL41[2:0]>	PB1 pin	TRGIN0
			PA3 pin	TRGIN1
			PN3 pin	TRGIN2
			T32A ch6 timer register A1 match trigger	T32A06TRGOUTCMPA1
			T32A ch6 timer register B1 match trigger	T32A06TRGOUTCMPB1
			T32A ch6 timer register C1 match trigger	T32A06TRGOUTCMPC1
TSPI ch3 (Note2)	TSPI3TRG (Input)	[TSEL0CR10] <INSEL42[2:0]>	PB1 pin	TRGIN0
			PA3 pin	TRGIN1
			PN3 pin	TRGIN2
			T32A ch6 timer register A1 match trigger	T32A06TRGOUTCMPA1
			T32A ch6 timer register B1 match trigger	T32A06TRGOUTCMPB1
			T32A ch6 timer register C1 match trigger	T32A06TRGOUTCMPC1
TSPI ch4 (Note3)	TSPI4TRG (Input)	[TSEL0CR10] <INSEL43[2:0]>	PB1 pin	TRGIN0
			PA3 pin	TRGIN1
			PN3 pin	TRGIN2
			T32A ch6 timer register A1 match trigger	T32A06TRGOUTCMPA1
			T32A ch6 timer register B1 match trigger	T32A06TRGOUTCMPB1
			T32A ch6 timer register C1 match trigger	T32A06TRGOUTCMPC1

Note1: The trigger source of the start trigger is selected by [TSEL0CRn]<INSELm[2:0]>. For details of trigger selector, refer to "2.2. Trigger Selector (TRGSEL)".

Note2: There is no TSPI ch1, ch2, and ch 3 in M3HL.

Note3: There is no TSPI ch4 in M3HN, M3HM, and M3HL.

2.19.7.2. T32A connection

In addition to this, the serial peripheral interface is connected with the peripheral function inside, as shown in the following table.

Table 2.114 TSPI Internal connection specification (Output)

Input/output	Functional Output		Trigger selector (Note1)	Destination		
		Signal name		Peripheral function		Signal name
Output	TSPI ch0 transmit completion	TSPI0TXEND	[TSEL0CR14] <INSEL56[2:0]>	T32A ch2	Timer A internal trigger input	T32A02TRGINAPCK
	TSPI ch0 receive completion	TSPI0RXEND				
	TSPI ch1 transmit completion (Note2)	TSPI1TXEND	[TSEL0CR14] <INSEL59[2:0]>	T32A ch3	Timer A internal trigger input	T32A03TRGINAPCK
	TSPI ch1 receive completion (Note2)	TSPI1RXEND				
	TSPI ch2 transmit completion (Note2)	TSPI2TXEND	[TSEL0CR15] <INSEL62[2:0]>	T32A ch4	Timer A internal trigger input	T32A04TRGINAPCK
	TSPI ch2 receive completion (Note2)	TSPI2RXEND				
	TSPI ch3 transmit completion (Note2)	TSPI3TXEND	[TSEL1CR0] <INSEL1[2:0]> (<INSEL65[2:0]>)	T32A ch5	Timer A internal trigger input	T32A05TRGINAPCK
	TSPI ch3 receive completion (Note2)	TSPI3RXEND				
	TSPI ch4 transmit completion (Note3)	TSPI4TXEND	[TSEL1CR1] <INSEL4[2:0]> (<INSEL68[2:0]>)	T32A ch6	Timer A internal trigger input	T32A06TRGINAPCK
	TSPI ch4 receive completion (Note3)	TSPI4RXEND				

Note1: The trigger source of the trigger input is selected by **[TSELxCRn]**<INSELM[2:0]>. For details of trigger selector, refer to "2.2. Trigger Selector (TRGSEL)".

Note2: There is no TSPI ch1, ch2, and ch3 in M3HL.

Note3: There is no TSPI ch4 in M3HN, M3HM, and M3HL.

2.20. LCD display control circuit (DLCD)

2.20.1. Built-in List

The following table shows the built-in list for each product.

Table 2.115 DLCD Built-in List

Product	DLCD Built-in (✓: Available, -: N/A)	Driving System
M3HQ	✓	Non-Bias driving
M3HP	✓	
M3HN	✓	
M3HM	✓	
M3HL	-	-

TPM3H Group(2) don't support the Display buffer function with the external trigger of *[DLCD CR3]<BTGL[1:0]>*.

2.20.2. Functional pin and port

The functional pin is assigned to the port below.

There is also a port which does not have a functional pin by a product.

Table 2.116 DLCD Functional pin and a port

Functional pin <RVDPIN>=000	Port	Product table (✓: Available, -: N/A)				
		M3HQ	M3HP	M3HN (Note2)	M3HM (Note2)	M3HL
DCOM0	PC3	✓	✓	✓	✓	-
DCOM1	PC2	✓	✓	✓	✓	-
DCOM2	PC1	✓	✓	✓	✓	-
DCOM3	PC0	✓	✓	✓	✓	-
SEG00	PV3	✓	✓	- (Note1)	- (Note1)	-
SEG01	PV2	✓	✓	- (Note1)	- (Note1)	-
SEG02	PV1	✓	✓	- (Note1)	- (Note1)	-
SEG03	PV0	✓	✓	- (Note1)	- (Note1)	-
SEG04	PP7	✓	✓	✓	-	-
SEG05	PP6	✓	✓	✓	✓	-
SEG06	PP5	✓	✓	✓	✓	-
SEG07	PP4	✓	✓	✓	✓	-
SEG08	PP3	✓	✓	✓	✓	-

Functional pin <RVDPIN>=000	Port	Product table (✓: Available, -: N/A)				
		M3HQ	M3HP	M3HN (Note2)	M3HM (Note2)	M3HL
SEG09	PK7	✓	✓	✓	✓	-
SEG10	PK6	✓	✓	✓	✓	-
SEG11	PK5	✓	✓	✓	✓	-
SEG12	PK4	✓	✓	✓	✓	-
SEG13	PK3	✓	✓	✓	✓	-
SEG14	PK2	✓	✓	✓	✓	-
SEG15	PK1	✓	✓	✓	✓	-
SEG16	PK0	✓	✓	✓	✓	-
SEG17	PJ5	✓	✓	✓	✓	-
SEG18	PJ4	✓	✓	✓	✓	-
SEG19	PJ3	✓	✓	✓	✓	-
SEG20	PJ2	✓	✓	✓	✓	-
SEG21	PJ1	✓	✓	✓	✓	-
SEG22	PJ0	✓	✓	✓	✓	-
SEG23	PN0	✓	✓	✓	✓	-
SEG24	PN1	✓	✓	✓	✓	-
SEG25	PN2	✓	✓	✓	✓	-
SEG26	PN3	✓	✓	✓	✓	-
SEG27	PN4	✓	✓	✓	✓	-
SEG28	PN5	✓	✓	✓	-	-
SEG29	PR7	✓	✓	-	-	-
SEG30	PR6	✓	✓	-	-	-
SEG31	PR5	✓	✓	-	-	-
SEG32	PR4	✓	✓	-	-	-
SEG33	PR3	✓	✓	✓	-	-
SEG34	PR2	✓	✓	✓	-	-
SEG35	PR1	✓	✓	✓	-	-
SEG36	PR0	✓	✓	✓	-	-
SEG37	PC6	✓	✓	✓	✓	-
SEG38	PC5	✓	✓	✓	✓	-
SEG39	PC4	✓	✓	✓	✓	-

Note1: DCOM function cannot be assigned even by using the Pin assignment switching function.

Note2: Please take care making display data and circuit board Layout, since some of the SEG signal pins are not assigned serially.

2.20.3. Pin setting registers

When using the LCD display function with TPM3H Group(2), set the following registers.

Register Name		Address
Output selection register	[AGPREG0]	0x4003FF00
Pin switching register	[AGPREG1]	0x4003FF01

Note: A register that is accessed in byte units. No bit band access.

2.20.3.1. Output selection

Depending on the LCD panel used and the reset status, set the LCD display pin to "Hi-Z" or "Pull-down" during reset.

This function reduces blurring and flickering of the LCD display.

The detail of [AGPREG0](Output selection register) is as following

Bit	Bit Symbol	After reset	Type	Description
7:1	-	0	R	Read as "0".
0	PDNKEEP	0	R/W	Output selection during reset 0: Hi-z 1: Pull-down

Note1: This register is initialized by Cold Reset (POR) only.

Note2: After <PDNKEEP> is set to "1", the change in the corresponding ports [PxFRn] register setting will not be reflected. When <PDNKEEP> is set from "0" to "1", the status at that time is kept.

Note3: When setting each port, such as after a reset occurs, set <PDNKEEP> = 0 before setting.

2.20.3.2. Pin Function switching

When the LCD display pin is selected and set, the drive capacity of the pin is 1/4 compared to general-purpose pins.

Set the following registers before initializing each port.

The detail of *[AGPREG1]*(Pin Function switching register) is as following.

Bit	Bit Symbol	After reset	Type	Description
7	-	0	R/W	Write as "0"
6	REG6	0	R/W	Pin Switching Function (SEG03 to 00) 0: General purpose 1: LCD display
5	REG5	0	R/W	Pin Switching Function (SEG36 to 29) 0: General purpose 1: LCD display
4	REG4	0	R/W	Pin Switching Function (SEG08 to 04) 0: General purpose 1: LCD display
3	REG3	0	R/W	Pin Switching Function (SEG28 to 23) 0: General purpose 1: LCD display
2	REG2	0	R/W	Pin Switching Function (SEG16 to 09) 0: General purpose 1: LCD display
1	REG1	0	R/W	Pin Switching Function (SEG22 to 17) 0: General purpose 1: LCD display
0	REG0	0	R/W	Pin Switching Function (DCOM3/2/1/0, SEG39 to 37) 0: General purpose 1: LCD display

2.20.4. Pin assignment switching function

This product can switch the pin assignment of function pin (DCOM3/2/1/0, SEG39 to SEG00) by the setting of *[DLCDCR4]<RVDPIN[2:0]>*.

For details, please refer to the Reference Manual "LCD display control circuit".

M3HN and M3HM can set four types as for *[DLCDCR4]<RVDPIN[2:0]>*=000, 001, 010, and 011.

2.21. Remote Control Signal Preprocessor (RMC)

2.21.1. Built-in channel

The built-in channel for each product is shown in the following table.

Table 2.117 RMC Built-in channel

Product	RMC Built-in channel (✓: Available, -: N/A)
	ch0
M3HQ	✓
M3HP	✓
M3HN	✓
M3HM	✓
M3HL	✓

2.21.2. Functional pin and port

The functional terminal is assigned to the following ports.

Table 2.118 RMC Functional pin and a port

Functional pin (Signal name)		Port	Product table (✓: Available, -: N/A)				
			M3HQ	M3HP	M3HN	M3HM	M3HL
RXIN0	Input	PB1	✓	✓	✓	✓	✓

2.21.3. Sampling clock

The remote control receiving circuit can select the sampling clock shown in the following table.

Table 2.119 RMC Sampling clock

Clock	Signal name	Clock source	Signal name
Low speed clock	fs	External Low speed oscillator	fs
Output clock from T32A ch7	TB0OUT	T32A ch7 Timer A output	T32A07OUTA

Note: Please select the sampling clock by `[RMC0FSSEL]<RMCCLK>`.

2.22. Digital Noise Filter Circuit (DNF)

2.22.1. Built-in unit

The built-in unit for each product is shown in the following table.

Table 2.120 DNF Built-in unit

Product	DNF Built-in unit (✓: Available, -: N/A)		
	unit A	unit B	unit C
M3HQ	✓	✓	✓
M3HP	✓	✓	✓
M3HN	✓	✓	✓
M3HM	✓	-	-
M3HL	✓	-	-

2.22.2. External interrupt pin and DNF

Digital noise filter circuits correspond to the following external interrupt pins.

Table 2.121 External interrupt pin and DNF correspondence

External interrupt Pin (signal name)	Port	Unit	Setup Register name	Product table (✓: Available, -: N/A)				
				M3HQ	M3HP	M3HN	M3HM	M3HL
INT00	PC0	A	[DNFAENCR]<NFEN0>	✓	✓	✓	✓	✓
INT01	PC1		[DNFAENCR]<NFEN1>	✓	✓	✓	✓	✓
INT02	PC2		[DNFAENCR]<NFEN2>	✓	✓	✓	✓	-
INT03	PB1		[DNFAENCR]<NFEN3>	✓	✓	✓	✓	✓
INT04	PJ4		[DNFAENCR]<NFEN4>	✓	✓	✓	✓	✓
INT05	PK1		[DNFAENCR]<NFEN5>	✓	✓	✓	✓	✓
INT06	PH3		[DNFAENCR]<NFEN6>	✓	✓	✓	✓	✓
INT07	PA6		[DNFAENCR]<NFEN7>	✓	✓	✓	✓	✓
INT08	PL3		[DNFAENCR]<NFEN8>	✓	✓	✓	✓	✓
INT09	PM2		[DNFAENCR]<NFEN9>	✓	✓	✓	✓	-
INT10	PN3		[DNFAENCR]<NFEN10>	✓	✓	✓	✓	✓
INT11	PA7		[DNFAENCR]<NFEN11>	✓	✓	✓	✓	✓
INT12	PL4		[DNFAENCR]<NFEN12>	✓	✓	✓	✓	✓
INT13	PK7		[DNFAENCR]<NFEN13>	✓	✓	✓	✓	-
INT14	PP3		[DNFAENCR]<NFEN14>	✓	✓	✓	✓	✓
INT15	PM6	[DNFAENCR]<NFEN15>	✓	✓	✓	-	-	
INT16	PB7	B	[DNFBENCR]<NFEN0>	✓	✓	✓	-	-
INT17	PV2		[DNFBENCR]<NFEN1>	✓	✓	-	-	-
INT18	PV3		[DNFBENCR]<NFEN2>	✓	✓	-	-	-
INT19	PH4		[DNFBENCR]<NFEN3>	✓	✓	-	-	-
INT20	PH5		[DNFBENCR]<NFEN4>	✓	✓	-	-	-
INT21	PH6		[DNFBENCR]<NFEN5>	✓	✓	-	-	-
INT22	PH7		[DNFBENCR]<NFEN6>	✓	✓	-	-	-
INT23	PT0		[DNFBENCR]<NFEN7>	✓	✓	-	-	-
INT24	PT1		[DNFBENCR]<NFEN8>	✓	✓	-	-	-
INT25	PT2		[DNFBENCR]<NFEN9>	✓	✓	-	-	-
INT26	PT3		[DNFBENCR]<NFEN10>	✓	✓	-	-	-
INT27	PG2		[DNFBENCR]<NFEN11>	✓	✓	-	-	-
INT28	PG3		[DNFBENCR]<NFEN12>	✓	✓	-	-	-
INT29	PT7		[DNFBENCR]<NFEN13>	✓	-	-	-	-
INT30	PU0		[DNFBENCR]<NFEN14>	✓	-	-	-	-
INT31	PU1	[DNFBENCR]<NFEN15>	✓	-	-	-	-	
INT32	PF3	C	[DNFCENCR]<NFEN0>	✓	✓	✓	-	-
INT33	PF2		[DNFCENCR]<NFEN1>	✓	✓	✓	-	-

2.22.3. Sampling source clock

The digital noise filter circuit uses the clock shown in the following table as a source clock of a sampling clock.

Table 2.122 DNF Sampling source clock

Clock
fc

2.23. CRC calculation Circuit (CRC)

2.23.1. Built-in channel

The built-in channel for each product is shown in the following table.

Table 2.123 CRC Built-in channel

Product	CRC Built-in channel (✓: Available, -: N/A)
M3HQ	✓
M3HP	✓
M3HN	✓
M3HM	✓
M3HL	✓

2.24. RAM Parity (RAMP)

2.24.1. Built-in channel

The built-in channel for each product is shown in the following table.

Table 2.124 RAM Parity Built-in channel

Product	RAMP Built-in channel (✓: Available, -: N/A)
M3HQ	✓
M3HP	✓
M3HN	✓
M3HM	✓
M3HL	✓

2.24.2. Error judgment Block Area

Table 2.125 RAM area and address of RAM Parity

Register name	RAM area address	Product table (✓: Available, -: N/A)				
		M3HQ	M3HP	M3HN	M3HM	M3HL
[RPARST]<RPARFG3>	0x20020000-0x200207FF	✓	✓	✓	✓	✓
[RPARST]<RPARFG2>	0x20010000-0x2001FFFF	✓	✓	✓	✓	✓
[RPARST]<RPARFG1>	0x20008000-0x2000FFFF	✓	✓	✓	✓	✓
[RPARST]<RPARFG0>	0x20000000-0x20007FFF	✓	✓	✓	✓	✓

2.25. Trimming Circuit (TRM)

2.25.1. Built-in List

The following table shows the built-in list for each product.

Table 2.126 TRM Built-in List

Product	Built-in TRM (✓: Available, -: N/A)
M3HQ	✓
M3HP	✓
M3HN	✓
M3HM	✓
M3HL	✓

2.25.2. Object oscillator

The object oscillator of a trimming circuit is an oscillator shown in the following table.

Table 2.127 TRM Trimming oscillator

Oscillator	Oscillator name
Internal High Speed Oscillator 1	IHOSC1

3. Revision History

Table 3.1 Revision History

Revision	Date	Description
1.0	2023-04-28	First Release

RESTRICTIONS ON PRODUCT USE

Toshiba Corporation and its subsidiaries and affiliates are collectively referred to as "TOSHIBA". Hardware, software and systems described in this document are collectively referred to as "Product".

- TOSHIBA reserves the right to make changes to the information in this document and related Product without notice.
- This document and any information herein may not be reproduced without prior written permission from TOSHIBA. Even with TOSHIBA's written permission, reproduction is permissible only if reproduction is without alteration/omission.
- Though TOSHIBA works continually to improve Product's quality and reliability, Product can malfunction or fail. Customers are responsible for complying with safety standards and for providing adequate designs and safeguards for their hardware, software and systems which minimize risk and avoid situations in which a malfunction or failure of Product could cause loss of human life, bodily injury or damage to property, including data loss or corruption. Before customers use the Product, create designs including the Product, or incorporate the Product into their own applications, customers must also refer to and comply with (a) the latest versions of all relevant TOSHIBA information, including without limitation, this document, the specifications, the data sheets and application notes for Product and the precautions and conditions set forth in the "TOSHIBA Semiconductor Reliability Handbook" and (b) the instructions for the application with which the Product will be used with or for. Customers are solely responsible for all aspects of their own product design or applications, including but not limited to (a) determining the appropriateness of the use of this Product in such design or applications; (b) evaluating and determining the applicability of any information contained in this document, or in charts, diagrams, programs, algorithms, sample application circuits, or any other referenced documents; and (c) validating all operating parameters for such designs and applications. **TOSHIBA ASSUMES NO LIABILITY FOR CUSTOMERS' PRODUCT DESIGN OR APPLICATIONS.**
- **PRODUCT IS NEITHER INTENDED NOR WARRANTED FOR USE IN EQUIPMENTS OR SYSTEMS THAT REQUIRE EXTRAORDINARILY HIGH LEVELS OF QUALITY AND/OR RELIABILITY, AND/OR A MALFUNCTION OR FAILURE OF WHICH MAY CAUSE LOSS OF HUMAN LIFE, BODILY INJURY, SERIOUS PROPERTY DAMAGE AND/OR SERIOUS PUBLIC IMPACT ("UNINTENDED USE").** Except for specific applications as expressly stated in this document, Unintended Use includes, without limitation, equipment used in nuclear facilities, equipment used in the aerospace industry, lifesaving and/or life supporting medical equipment, equipment used for automobiles, trains, ships and other transportation, traffic signaling equipment, equipment used to control combustions or explosions, safety devices, elevators and escalators, and devices related to power plant. **IF YOU USE PRODUCT FOR UNINTENDED USE, TOSHIBA ASSUMES NO LIABILITY FOR PRODUCT.** For details, please contact your TOSHIBA sales representative or contact us via our website.
- Do not disassemble, analyze, reverse-engineer, alter, modify, translate or copy Product, whether in whole or in part.
- Product shall not be used for or incorporated into any products or systems whose manufacture, use, or sale is prohibited under any applicable laws or regulations.
- The information contained herein is presented only as guidance for Product use. No responsibility is assumed by TOSHIBA for any infringement of patents or any other intellectual property rights of third parties that may result from the use of Product. No license to any intellectual property right is granted by this document, whether express or implied, by estoppel or otherwise.
- **ABSENT A WRITTEN SIGNED AGREEMENT, EXCEPT AS PROVIDED IN THE RELEVANT TERMS AND CONDITIONS OF SALE FOR PRODUCT, AND TO THE MAXIMUM EXTENT ALLOWABLE BY LAW, TOSHIBA (1) ASSUMES NO LIABILITY WHATSOEVER, INCLUDING WITHOUT LIMITATION, INDIRECT, CONSEQUENTIAL, SPECIAL, OR INCIDENTAL DAMAGES OR LOSS, INCLUDING WITHOUT LIMITATION, LOSS OF PROFITS, LOSS OF OPPORTUNITIES, BUSINESS INTERRUPTION AND LOSS OF DATA, AND (2) DISCLAIMS ANY AND ALL EXPRESS OR IMPLIED WARRANTIES AND CONDITIONS RELATED TO SALE, USE OF PRODUCT, OR INFORMATION, INCLUDING WARRANTIES OR CONDITIONS OF MERCHANTABILITY, FITNESS FOR A PARTICULAR PURPOSE, ACCURACY OF INFORMATION, OR NONINFRINGEMENT.**
- Do not use or otherwise make available Product or related software or technology for any military purposes, including without limitation, for the design, development, use, stockpiling or manufacturing of nuclear, chemical, or biological weapons or missile technology products (mass destruction weapons). Product and related software and technology may be controlled under the applicable export laws and regulations including, without limitation, the Japanese Foreign Exchange and Foreign Trade Law and the U.S. Export Administration Regulations. Export and re-export of Product or related software or technology are strictly prohibited except in compliance with all applicable export laws and regulations.
- Please contact your TOSHIBA sales representative for details as to environmental matters such as the RoHS compatibility of Product. Please use Product in compliance with all applicable laws and regulations that regulate the inclusion or use of controlled substances, including without limitation, the EU RoHS Directive. **TOSHIBA ASSUMES NO LIABILITY FOR DAMAGES OR LOSSES OCCURRING AS A RESULT OF NONCOMPLIANCE WITH APPLICABLE LAWS AND REGULATIONS.**