

32-bit RISC Microcontroller

**TXZ+ Family
TMPM3H Group(2)**

**Reference Manual
Input/Output Ports
(PORT-M3H(2))**

Revision 1.1

2025-02

Toshiba Electronic Devices & Storage Corporation

Contents

Preface	5
Related Document	5
Conventions	6
Terms and Abbreviations	8
1. Outlines	9
2. Function	10
2.1. Clock Supply	10
3. Signal Connection List	11
4. Registers	24
4.1. List of Register	25
4.2. List of Port Functions and Settings	28
4.2.1. Setting of Using Alternated Pin	28
4.2.2. PORT A	29
4.2.3. PORT B	30
4.2.4. PORT C	31
4.2.5. PORT D	32
4.2.6. PORT E	33
4.2.7. PORT F	34
4.2.8. PORT G	35
4.2.9. PORT H	36
4.2.10. PORT J	37
4.2.11. PORT K	38
4.2.12. PORT L	40
4.2.13. PORT M	41
4.2.14. PORT N	42
4.2.15. PORT P	43
4.2.16. PORT R	44
4.2.17. PORT T	45
4.2.18. PORT U	46
4.2.19. PORT V	47
5. Block Diagrams of Ports	48
5.1. Type FTU1	49
5.2. Type FTU2	50
5.3. Type FTU3	51
5.4. Type FTU4	52
5.5. Type FTU5	53
5.6. Type FTU6	54
5.7. Type FTU10	55
5.8. Type FTU11	56
5.9. Type FTU12	57
5.10. Type FTU13	58

6. Precaution	59
6.1. Pin Status during Reset Period.....	59
6.2. Unused Pins.....	59
6.3. Important Points of Using Debug Interface Pins Used as General-purpose Ports.....	59
7. Revision History	60
RESTRICTIONS ON PRODUCT USE	61

List of Figures

Figure 5.1	Port Type FTU1	49
Figure 5.2	Port Type FTU2	50
Figure 5.3	Port Type FTU3	51
Figure 5.4	Port Type FTU4	52
Figure 5.5	Port Type FTU5	53
Figure 5.6	Port Type FTU6	54
Figure 5.7	Port Type FTU10	55
Figure 5.8	Port Type FTU11	56
Figure 5.9	Port Type FTU12	57
Figure 5.10	Port Type FTU13	58

List of Tables

Table 3.1	Signal Connection List: UART ch0,1	11
Table 3.2	Signal Connection List: UART ch2,3	12
Table 3.3	Signal Connection List: UART ch4,5,6,7	13
Table 3.4	Signal Connection List: I2C/EI2C/TSPI ch0,1	14
Table 3.5	Signal Connection List: TSPI ch2,3,4/T32A ch0.....	15
Table 3.6	Signal Connection List: T32A ch1,2.....	16
Table 3.7	Signal Connection List: T32A ch3,4,5.....	17
Table 3.8	Signal Connection List: T32A ch6,7.....	18
Table 3.9	Signal Connection List: ADC/DAC.....	19
Table 3.10	Signal Connection List: INT	20
Table 3.11	Signal Connection List: A-PMD/A-ENC32/TRGSEL/REM/RTC	21
Table 3.12	Signal Connection List: DLCD	22
Table 3.13	Signal Connection List: DLCD/ JTAG/SW/TRACE/Control Pin/IO	23
Table 4.1	Ports Base Address	25
Table 4.2	Register List (1/4).....	26
Table 4.3	Register List (2/4).....	26
Table 4.4	Register List (3/4).....	27
Table 4.5	Register List (4/4).....	27
Table 4.6	Port A Registers Setting.....	29
Table 4.7	Port B Registers Setting.....	30
Table 4.8	Port C Registers Setting	31
Table 4.9	Port D Registers Setting	32
Table 4.10	Port E Registers Setting.....	33
Table 4.11	Port F Registers Setting.....	34
Table 4.12	Port G Registers Setting	35
Table 4.13	Port H Registers Setting	36
Table 4.14	Port J Registers Setting	37
Table 4.15	Port K Registers Setting.....	38
Table 4.16	Port L Registers Setting	40
Table 4.17	Port M Registers Setting	41
Table 4.18	Port N Registers Setting	42
Table 4.19	Port P Registers Setting.....	43
Table 4.20	Port R Registers Setting	44
Table 4.21	Port T Registers Setting.....	45
Table 4.22	Port U Registers Setting	46
Table 4.23	Port V Registers Setting.....	47
Table 7.1	Revision History	60

Preface

Related Document

Document name
Product Information
Clock Control and Operation Mode
Exception
Flash Memory
8-bit Digital to Analog Convertor
I ² C Interface
I ² C Interface Version A
Serial Peripheral Interface
12-bit Analog to Digital Convertor
32-bit Timer Event Counter
Asynchronous Serial Communication Circuit
Real Time Clock
Remote Control Signal preprocessor
Advanced Programmable Motor Control Circuit
Advanced Encoder Input Circuit (32-bit)
Debug Interface
LCD Display Control Circuit

Conventions

- Numeric formats follow the rules as shown below:

Hexadecimal:	0xABC	
Decimal:	123 or 0d123	- Only when it needs to be explicitly shown that they are decimal numbers.
Binary:	0b111	- It is possible to omit the "0b" when the number of bits can be distinctly understood from a sentence.
- "_N" is added to the end of signal names to indicate low active signals.
- It is called "assert" that a signal moves to its active level, "deassert" to its inactive level.
- When two or more signal names are referred, they are described like as [m:n].
 Example: S[3:0] shows four signal names S3, S2, S1 and S0 together.
- The characters surrounded by [] defines the register.
 Example: [ABCD]
- "N" substitutes suffix number of two or more same kind of registers, fields, and bit names.
 Example: [XYZ1], [XYZ2], [XYZ3] → [XYZn]
- "x" substitutes suffix number or character of units and channels in the register list.
- In case of unit, "x" means A, B, and C, ...
 Example: [ADACR0], [ADBCR0], [ADCCR0] → [ADxCR0]
- In case of channel, "x" means 0, 1, and 2, ...
 Example: [T32A0RUNA], [T32A1RUNA], [T32A2RUNA] → [T32AxRUNA]
- The bit range of a register is written like as [m: n].
 Example: Bit[3: 0] expresses the range of bit 3 to 0.
- The configuration value of a register is expressed by either the hexadecimal number or the binary number.
 Example: [ABCD]<EFG> = 0x01 (hexadecimal), [XYZn]<VW> = 1 (binary)
- Word and byte represent the following bit length.

Byte:	8 bits
Half word:	16 bits
Word:	32 bits
Double word:	64 bits
- Properties of each bit in a register are expressed as follows:

R:	Read only
W:	Write only
R/W:	Read and write are possible.
- Unless otherwise specified, register access supports only word access.
- The register defined as "Reserved" must not be rewritten. Moreover, do not use the read value.
- The value read from the bit having default value of "-" is unknown.
- When a register containing both of writable bits and read-only bits is written, read-only bits should be written with their default value, In the cases that default is "-", follow the definition of each register.
- Reserved bits of the write-only register should be written with their default value. In the cases that default is "-", follow the definition of each register.
- Do not use read-modified-write processing to the register of a definition which is different by writing and read out.

All other company names, product names, and service names mentioned herein may be trademarks of their respective companies.

Terms and Abbreviations

Some of abbreviations used in this document are as follows:

JTAG Joint Test Action Group

SW Serial Wire

1. Outlines

It is described about the register and setting of port. A list of the functions is indicated below.

Function classification	Function	Description
Port	-	Programmable pull-up /Programmable pull-down /Open-drain output are possible.
Peripheral function pins	Clock Output	SCOUT pin
	External Interrupt	Interrupt pin has a noise filter(Filter width 30ns Typ.).
	32-bit Timer Event Counter	External trigger Input pin. Timer output pin.
	Real Time Clock	1Hz clock output pin
	Serial Peripheral Interface	Chip select input for slave operation 1 pin, Chip select 2 pins, Serial data of transmission pin, Serial data reception pin, Serial clock input/output pin
	Asynchronous Serial Communication Circuit	Data input pin, Data output 2 pins, Request to send signal pin, Receivable input pin.
	I ² C Interface	SCL signal pin, SDA signal pin
	EI ² C Interface	SCL signal pin, SDA signal pin
	Remote Control Signal preprocessor	Remote control data entry pin
	Analog to Digital Convertor	Analog input pin
	Digital to Analog Convertor	DAC output pin
	Advanced Programmable Motor Control Circuit	X/Y/Z phase output pins, U/V/W phase output pins, EMG detection input pin, OVV detection input pin
	Advanced Encoder Input Circuit (32-bit)	Encoder input pins
	Trigger Input	External trigger input pins
Digital LCD	Segment pins, Common pins	
Debug pins	JTAG	JTAG Test Mode Selection pin, JTAG Serial clock input pin, JTAG Serial data output pin, JTAG Serial data input pin, JTAG Test reset input pin
	SW	Serial wire data input/output pin, Serial wire clock input pin, Serial wire viewer output pin
	Trace	Trace clock output pin, Trace data output 4pins
Control pins	High-speed clock	High-speed resonator connection pin, External clock input
	Low-speed clock	Low-speed resonator connection pin
	BOOT mode control	BOOT mode control pin

2. Function

2.1. Clock Supply

When PORT is used, the corresponding clock enable bits should be set to "1" (Clock supply) in fsys supply stop register A (*[CGFSYSENA]* and *[CGFSYSMENA]*), fsys supply stop register B (*[CGFSYSENB]* and *[CGFSYSMENB]*), fsys supply stop register C (*[CGFSYSMENC]*), and fc supply stop register (*[CGFCEN]*).

The corresponding registers and the bit locations depend on a product. Some products do not have all registers. For the details, refer to Reference manual "Clock Control and Operation Mode".

3. Signal Connection List

This table is sorted the function pins by the signal name of the block diagram which is described each reference manual. Register setting of the peripherals function is being explained in the port order, so please use for a reverse lookup of port name.

The numerical value shows the pin number.

Table 3.1 Signal Connection List: UART ch0,1

Related reference manual	Function pin name	Port name	M3HQ (LQFP144)	M3HP (LQFP128-1414)	M3HP (LQFP128-1420)	M3HN (LQFP100)	M3HN (QFP100)	M3HM (LQFP80)	M3HL (LQFP64)	
Asynchronous Serial Communication Circuit	UT0TXDA	PA1	27	23	26	17	19	16	14	
		PA2	26	22	25	16	18	15	13	
		PM1	35	31	34	24	26	19	-	
		PM2	34	30	33	23	25	18	-	
	UT0TXDB	PA0	28	24	27	18	20	17	15	
		PM0	36	32	35	25	27	20	16	
	UT0RXD	PA2	26	22	25	16	18	15	13	
		PA1	27	23	26	17	19	16	14	
		PM2	34	30	33	23	25	18	-	
	UT0CTS_N	PM1	35	31	34	24	26	19	-	
		PM3	33	29	32	22	24	-	-	
	UT0RTS_N	PM4	32	28	31	21	23	-	-	
		PM3	33	29	32	22	24	-	-	
	Asynchronous Serial Communication Circuit	UT1TXDA	PJ1	105	92	95	72	74	57	45
			PJ2	106	93	96	73	75	58	46
			PK1	111	98	101	78	80	63	51
PK2			112	99	102	79	81	64	52	
UT1TXDB		PJ0	104	91	94	71	73	56	44	
		PK0	110	97	100	77	79	62	50	
UT1RXD		PJ2	106	93	96	73	75	58	46	
		PJ1	105	92	95	72	74	57	45	
		PK2	112	99	102	79	81	64	52	
UT1CTS_N		PK1	111	98	101	78	80	63	51	
		PJ3	107	94	97	74	76	59	47	
		PJ4	108	95	98	75	77	60	48	
		PK3	113	100	103	80	82	65	53	
UT1RTS_N		PK4	114	101	104	81	83	66	54	
		PJ4	108	95	98	75	77	60	48	
		PJ3	107	94	97	74	76	59	47	
	PK4	114	101	104	81	83	66	54		
		PK3	113	100	103	80	82	65	53	

Table 3.2 Signal Connection List: UART ch2,3

Related reference manual	Function pin name	Port name	M3HQ (LQFP144)	M3HP (LQFP128-1414)	M3HP (LQFP128-1420)	M3HN (LQFP100)	M3HN (QFP100)	M3HM (LQFP80)	M3HL (LQFP64)
Asynchronous Serial Communication Circuit	UT2TXDA	PB2	39	35	38	28	30	23	19
		PB3	40	36	39	29	31	24	20
		PL0	47	41	44	34	36	26	21
		PL1	48	42	45	35	37	27	22
	UT2RXD	PB3	40	36	39	29	31	24	20
		PB2	39	35	38	28	30	23	19
		PL1	48	42	45	35	37	27	22
		PL0	47	41	44	34	36	26	21
	UT2CTS_N	PB4	41	37	40	30	32	25	-
		PB5	42	38	41	31	33	-	-
		PL2	49	43	46	36	38	28	23
		PL3	50	44	47	37	39	29	24
	UT2RTS_N	PB5	42	38	41	31	33	-	-
		PB4	41	37	40	30	32	25	-
		PL3	50	44	47	37	39	29	24
		PL2	49	43	46	36	38	28	23
Related reference manual	Function pin name	Port name	M3HQ (LQFP144)	M3HP (LQFP128-1414)	M3HP (LQFP128-1420)	M3HN (LQFP100)	M3HN (QFP100)	M3HM (LQFP80)	M3HL (LQFP64)
Asynchronous Serial Communication Circuit	UT3TXDA	PA7	21	17	20	11	13	10	10
		PA6	22	18	21	12	14	11	11
		PG3	16	12	15	-	-	-	-
		PG2	15	11	14	-	-	-	-
	UT3TXDB	PG4	17	13	16	-	-	-	-
	UT3RXD	PA6	22	18	21	12	14	11	11
		PA7	21	17	20	11	13	10	10
		PG2	15	11	14	-	-	-	-
PG3		16	12	15	-	-	-	-	

Table 3.3 Signal Connection List: UART ch4,5,6,7

Related reference manual	Function pin name	Port name	M3HQ (LQFP144)	M3HP (LQFP128-1414)	M3HP (LQFP128-1420)	M3HN (LQFP100)	M3HN (QFP100)	M3HM (LQFP80)	M3HL (LQFP64)
Asynchronous Serial Communication Circuit	UT4TXDA	PC3	86	73	76	57	59	47	38
		PC4	87	74	77	58	60	48	39
		PV6	81	-	-	-	-	-	-
		PV7	82	-	-	-	-	-	-
	UT4TXDB	PC2	85	72	75	56	58	46	-
		PV5	80	-	-	-	-	-	-
	UT4RXD	PC4	87	74	77	58	60	48	39
		PC3	86	73	76	57	59	47	38
		PV7	82	-	-	-	-	-	-
		PV6	81	-	-	-	-	-	-
	UT4CTS_N	PC5	88	75	78	59	61	49	-
		PC6	89	76	79	60	62	50	-
UT4RTS_N	PC6	89	76	79	60	62	50	-	
	PC5	88	75	78	59	61	49	-	
Related reference manual	Function pin name	Port name	M3HQ (LQFP144)	M3HP (LQFP128-1414)	M3HP (LQFP128-1420)	M3HN (LQFP100)	M3HN (QFP100)	M3HM (LQFP80)	M3HL (LQFP64)
Asynchronous Serial Communication Circuit	UT5TXDA	PN3	100	87	90	67	69	52	41
		PN2	101	88	91	68	70	53	42
	UT5TXDB	PN4	99	86	89	66	68	51	40
	UT5RXD	PN2	101	88	91	68	70	53	42
		PN3	100	87	90	67	69	52	41
	UT5CTS_N	PN1	102	89	92	69	71	54	43
		PN0	103	90	93	70	72	55	-
	UT5RTS_N	PN0	103	90	93	70	72	55	-
PN1		102	89	92	69	71	54	43	
Related reference manual	Function pin name	Port name	M3HQ (LQFP144)	M3HP (LQFP128-1414)	M3HP (LQFP128-1420)	M3HN (LQFP100)	M3HN (QFP100)	M3HM (LQFP80)	M3HL (LQFP64)
Asynchronous Serial Communication Circuit	UT6TXDA	PK6	116	103	106	83	85	68	56
		PK5	115	102	105	82	84	67	55
	UT6TXDB	PK7	117	104	107	84	86	69	-
	UT6RXD	PK5	115	102	105	82	84	67	55
PK6		116	103	106	83	85	68	56	
Related reference manual	Function pin name	Port name	M3HQ (LQFP144)	M3HP (LQFP128-1414)	M3HP (LQFP128-1420)	M3HN (LQFP100)	M3HN (QFP100)	M3HM (LQFP80)	M3HL (LQFP64)
Asynchronous Serial Communication Circuit	UT7TXDA	PR1	91	78	81	62	64	-	-
		PR0	90	77	80	61	63	-	-
	UT7TXDB	PR2	92	79	82	63	65	-	-
	UT7RXD	PR0	90	77	80	61	63	-	-
PR1		91	78	81	62	64	-	-	

Table 3.4 Signal Connection List: I2C/EI2C/TSPI ch0,1

Related reference manual	Function pin name	Port name	M3HQ (LQFP144)	M3HP (LQFP128-1414)	M3HP (LQFP128-1420)	M3HN (LQFP100)	M3HN (QFP100)	M3HM (LQFP80)	M3HL (LQFP64)
I ² C Interface	I2C0SCL	PC0	83	70	73	54	56	44	36
	I2C0SDA	PC1	84	71	74	55	57	45	37
	I2C1SCL	PA4	24	20	23	14	16	13	-
	I2C1SDA	PA5	23	19	22	13	15	12	-
	I2C2SCL	PL0	47	41	44	34	36	26	21
	I2C2SDA	PL1	48	42	45	35	37	27	22
	I2C3SCL	PT1	61	51	54	-	-	-	-
	I2C3SDA	PT0	62	52	55	-	-	-	-
Related reference manual	Function pin name	Port name	M3HQ (LQFP144)	M3HP (LQFP128-1414)	M3HP (LQFP128-1420)	M3HN (LQFP100)	M3HN (QFP100)	M3HM (LQFP80)	M3HL (LQFP64)
I ² C Interface Version A	EI2C0SCL	PC0	83	70	73	54	56	44	36
	EI2C0SDA	PC1	84	71	74	55	57	45	37
	EI2C1SCL	PA4	24	20	23	14	16	13	-
	EI2C1SDA	PA5	23	19	22	13	15	12	-
	EI2C2SCL	PL0	47	41	44	34	36	26	21
	EI2C2SDA	PL1	48	42	45	35	37	27	22
	EI2C3SCL	PT1	61	51	54	-	-	-	-
	EI2C3SDA	PT0	62	52	55	-	-	-	-
Related reference manual	Function pin name	Port name	M3HQ (LQFP144)	M3HP (LQFP128-1414)	M3HP (LQFP128-1420)	M3HN (LQFP100)	M3HN (QFP100)	M3HM (LQFP80)	M3HL (LQFP64)
Serial Peripheral Interface	TSPI0SCK	PM0	36	32	35	25	27	20	16
		PA0	28	24	27	18	20	17	15
	TSPI0TXD	PM1	35	31	34	24	26	19	-
		PA1	27	23	26	17	19	16	14
	TSPI0RXD	PM2	34	30	33	23	25	18	-
		PA2	26	22	25	16	18	15	13
	TSPI0CS0	PM3	33	29	32	22	24	-	-
		PA3	25	21	24	15	17	14	12
	TSPI0CS1	PM4	32	28	31	21	23	-	-
		PA4	24	20	23	14	16	13	-
	TSPI0CSIN	PM3	33	29	32	22	24	-	-
		PA3	25	21	24	15	17	14	12
Related reference manual	Function pin name	Port name	M3HQ (LQFP144)	M3HP (LQFP128-1414)	M3HP (LQFP128-1420)	M3HN (LQFP100)	M3HN (QFP100)	M3HM (LQFP80)	M3HL (LQFP64)
Serial Peripheral Interface	TSPI1SCK	PB2	39	35	38	28	30	23	-
	TSPI1TXD	PB3	40	36	39	29	31	24	-
	TSPI1RXD	PB4	41	37	40	30	32	25	-
	TSPI1CS0	PB5	42	38	41	31	33	-	-
	TSPI1CS1	PB6	43	39	42	32	34	-	-
	TSPI1CSIN	PB5	42	38	41	31	33	-	-

Table 3.5 Signal Connection List: TSPI ch2,3,4/T32A ch0

Related reference manual	Function pin name	Port name	M3HQ (LQFP144)	M3HP (LQFP128-1414)	M3HP (LQFP128-1420)	M3HN (LQFP100)	M3HN (QFP100)	M3HM (LQFP80)	M3HL (LQFP64)
Serial Peripheral Interface	TSPI2SCK	PP0	63	53	56	41	43	31	-
		PT2	60	50	53	-	-	-	-
	TSPI2TXD	PP1	64	54	57	42	44	32	-
		PT3	59	49	52	-	-	-	-
	TSPI2RXD	PP2	65	55	58	43	45	33	-
		PT4	58	-	-	-	-	-	-
	TSPI2CS0	PT1	61	51	54	-	-	-	-
TSPI2CS1	PT0	62	52	55	-	-	-	-	
TSPI2CSIN	PT1	61	51	54	-	-	-	-	
Related reference manual	Function pin name	Port name	M3HQ (LQFP144)	M3HP (LQFP128-1414)	M3HP (LQFP128-1420)	M3HN (LQFP100)	M3HN (QFP100)	M3HM (LQFP80)	M3HL (LQFP64)
Serial Peripheral Interface	TSPI3SCK	PP5	120	107	110	87	89	72	-
	TSPI3TXD	PP4	119	106	109	86	88	71	-
	TSPI3RXD	PP3	118	105	108	85	87	70	-
	TSPI3CS0	PP6	121	108	111	88	90	73	-
	TSPI3CS1	PP7	122	109	112	89	91	-	-
	TSPI3CSIN	PP6	121	108	111	88	90	73	-
Related reference manual	Function pin name	Port name	M3HQ (LQFP144)	M3HP (LQFP128-1414)	M3HP (LQFP128-1420)	M3HN (LQFP100)	M3HN (QFP100)	M3HM (LQFP80)	M3HL (LQFP64)
Serial Peripheral Interface	TSPI4SCK	PH4	76	66	69	-	-	-	-
	TSPI4TXD	PH5	77	67	70	-	-	-	-
	TSPI4RXD	PH6	78	68	71	-	-	-	-
Related reference manual	Function pin name	Port name	M3HQ (LQFP144)	M3HP (LQFP128-1414)	M3HP (LQFP128-1420)	M3HN (LQFP100)	M3HN (QFP100)	M3HM (LQFP80)	M3HL (LQFP64)
32-bit Timer Event Counter	T32A00OUTA	PA0	28	24	27	18	20	17	15
		PM0	36	32	35	25	27	20	16
	T32A00OUTB	PA3	25	21	24	15	17	14	12
		PM3	33	29	32	22	24	-	-
	T32A00OUTC	PA0	28	24	27	18	20	17	15
		PM0	36	32	35	25	27	20	16
	T32A00INA0	PA1	27	23	26	17	19	16	14
		PM1	35	31	34	24	26	19	-
	T32A00INA1	PA2	26	22	25	16	18	15	13
		PM2	34	30	33	23	25	18	-
	T32A00INB0	PA4	24	20	23	14	16	13	-
		PM4	32	28	31	21	23	-	-
	T32A00INB1	PA5	23	19	22	13	15	12	-
		PM5	31	27	30	20	22	-	-
	T32A00INC0	PA1	27	23	26	17	19	16	14
		PM1	35	31	34	24	26	19	-
	T32A00INC1	PA2	26	22	25	16	18	15	13
		PM2	34	30	33	23	25	18	-

Table 3.6 Signal Connection List: T32A ch1,2

Related reference manual	Function pin name	Port name	M3HQ (LQFP144)	M3HP (LQFP128-1414)	M3HP (LQFP128-1420)	M3HN (LQFP100)	M3HN (QFP100)	M3HM (LQFP80)	M3HL (LQFP64)
32-bit Timer Event Counter	T32A01OUTA	PB0	37	33	36	26	28	21	17
		PP0	63	53	56	41	43	31	-
	T32A01OUTB	PB3	40	36	39	29	31	24	20
	T32A01OUTC	PB0	37	33	36	26	28	21	17
		PP0	63	53	56	41	43	31	-
	T32A01INA0	PB1	38	34	37	27	29	22	18
		PP1	64	54	57	42	44	32	-
	T32A01INA1	PB2	39	35	38	28	30	23	19
		PP2	65	55	58	43	45	33	-
	T32A01INB0	PB4	41	37	40	30	32	25	-
	T32A01INB1	PB5	42	38	41	31	33	-	-
	T32A01INC0	PB1	38	34	37	27	29	22	18
		PP1	64	54	57	42	44	32	-
	T32A01INC1	PB2	39	35	38	28	30	23	19
PP2		65	55	58	43	45	33	-	
Related reference manual	Function pin name	Port name	M3HQ (LQFP144)	M3HP (LQFP128-1414)	M3HP (LQFP128-1420)	M3HN (LQFP100)	M3HN (QFP100)	M3HM (LQFP80)	M3HL (LQFP64)
32-bit Timer Event Counter	T32A02OUTA	PC0	83	70	73	54	56	44	36
		PR0	90	77	80	61	63	-	-
	T32A02OUTB	PC3	86	73	76	57	59	47	38
	T32A02OUTC	PC0	83	70	73	54	56	44	36
		PR0	90	77	80	61	63	-	-
	T32A02INA0	PC1	84	71	74	55	57	45	37
		PR1	91	78	81	62	64	-	-
	T32A02INA1	PC2	85	72	75	56	58	46	-
		PR2	92	79	82	63	65	-	-
	T32A02INB0	PC4	87	74	77	58	60	48	39
	T32A02INB1	PC5	88	75	78	59	61	49	-
	T32A02INC0	PC1	84	71	74	55	57	45	37
		PR1	91	78	81	62	64	-	-
	T32A02INC1	PC2	85	72	75	56	58	46	-
PR2		92	79	82	63	65	-	-	

Table 3.7 Signal Connection List: T32A ch3,4,5

Related reference manual	Function pin name	Port name	M3HQ (LQFP144)	M3HP (LQFP128-1414)	M3HP (LQFP128-1420)	M3HN (LQFP100)	M3HN (QFP100)	M3HM (LQFP80)	M3HL (LQFP64)
32-bit Timer Event Counter	T32A03OUTA	PJ0	104	91	94	71	73	56	44
	T32A03OUTB	PJ3	107	94	97	74	76	59	47
	T32A03OUTC	PJ0	104	91	94	71	73	56	44
	T32A03INA0	PJ1	105	92	95	72	74	57	45
	T32A03INA1	PJ2	106	93	96	73	75	58	46
	T32A03INB0	PJ4	108	95	98	75	77	60	48
	T32A03INB1	PJ5	109	96	99	76	78	61	49
	T32A03INC0	PJ1	105	92	95	72	74	57	45
	T32A03INC1	PJ2	106	93	96	73	75	58	46
Related reference manual	Function pin name	Port name	M3HQ (LQFP144)	M3HP (LQFP128-1414)	M3HP (LQFP128-1420)	M3HN (LQFP100)	M3HN (QFP100)	M3HM (LQFP80)	M3HL (LQFP64)
32-bit Timer Event Counter	T32A04OUTA	PK2	112	99	102	79	81	64	52
	T32A04OUTB	PK5	115	102	105	82	84	67	55
	T32A04OUTC	PK2	112	99	102	79	81	64	52
	T32A04INA0	PK3	113	100	103	80	82	65	53
	T32A04INA1	PK4	114	101	104	81	83	66	54
	T32A04INB0	PK6	116	103	106	83	85	68	56
	T32A04INB1	PK7	117	104	107	84	86	69	-
	T32A04INC0	PK3	113	100	103	80	82	65	53
	T32A04INC1	PK4	114	101	104	81	83	66	54
Related reference manual	Function pin name	Port name	M3HQ (LQFP144)	M3HP (LQFP128-1414)	M3HP (LQFP128-1420)	M3HN (LQFP100)	M3HN (QFP100)	M3HM (LQFP80)	M3HL (LQFP64)
32-bit Timer Event Counter	T32A05OUTA	PN0	103	90	93	70	72	55	-
	T32A05OUTB	PN3	100	87	90	67	69	52	41
	T32A05OUTC	PN0	103	90	93	70	72	55	
	T32A05INA0	PN1	102	89	92	69	71	54	43
	T32A05INA1	PN2	101	88	91	68	70	53	42
	T32A05INB0	PN4	99	86	89	66	68	51	40
	T32A05INB1	PN5	98	85	88	65	67	-	-
	T32A05INC0	PN1	102	89	92	69	71	54	43
	T32A05INC1	PN2	101	88	91	68	70	53	42

Table 3.8 Signal Connection List: T32A ch6,7

Related reference manual	Function pin name	Port name	M3HQ (LQFP144)	M3HP (LQFP128-1414)	M3HP (LQFP128-1420)	M3HN (LQFP100)	M3HN (QFP100)	M3HM (LQFP80)	M3HL (LQFP64)
32-bit Timer Event Counter	T32A06OUTA	PL5	52	46	49	39	41	-	-
		PT5	57	-	-	-	-	-	-
	T32A06OUTB	PL2	49	43	46	36	38	28	23
		PT2	60	50	53	-	-	-	-
	T32A06OUTC	PL5	52	46	49	39	41	-	-
		PT5	57	-	-	-	-	-	-
	T32A06INA0	PL6	53	47	50	40	42	-	-
		PT6	56	-	-	-	-	-	-
	T32A06INA1	PL7	54	48	51	-	-	-	-
		PT7	55	-	-	-	-	-	-
	T32A06INB0	PL3	50	44	47	37	39	29	24
		PT3	59	49	52	-	-	-	-
	T32A06INB1	PL4	51	45	48	38	40	30	25
		PT4	58	-	-	-	-	-	-
	T32A06INC0	PL6	53	47	50	40	42	-	-
		PT6	56	-	-	-	-	-	-
T32A06INC1	PL7	54	48	51	-	-	-	-	
	PT7	55	-	-	-	-	-	-	
Related reference manual	Function pin name	Port name	M3HQ (LQFP144)	M3HP (LQFP128-1414)	M3HP (LQFP128-1420)	M3HN (LQFP100)	M3HN (QFP100)	M3HM (LQFP80)	M3HL (LQFP64)
32-bit Timer Event Counter	T32A07OUTA	PG2	15	11	14	-	-	-	-
	T32A07OUTB	PG5	18	14	17	-	-	-	-
	T32A07OUTC	PG2	15	11	14	-	-	-	-
	T32A07INA0	PG3	16	12	15	-	-	-	-
	T32A07INA1	PG4	17	13	16	-	-	-	-
	T32A07INB0	PG6	19	15	18	-	-	-	-
	T32A07INB1	PG7	20	16	19	-	-	-	-
	T32A07INC0	PG3	16	12	15	-	-	-	-
	T32A07INC1	PG4	17	13	16	-	-	-	-

Table 3.9 Signal Connection List: ADC/DAC

Related reference manual	Function pin name	Port name	M3HQ (LQFP144)	M3HP (LQFP128-1414)	M3HP (LQFP128-1420)	M3HN (LQFP100)	M3HN (QFP100)	M3HM (LQFP80)	M3HL (LQFP64)
12-bit Analog to Digital Convertor	AINA00	PD0	6	6	9	6	8	5	5
	AINA01	PD1	5	5	8	5	7	4	4
	AINA02	PD2	4	4	7	4	6	3	3
	AINA03	PD3	3	3	6	3	5	-	-
	AINA04	PE0	2	2	5	2	4	2	2
	AINA05	PE1	1	1	4	1	3	1	1
	AINA06	PE2	144	128	3	100	2	80	64
	AINA07	PE3	143	127	2	99	1	79	63
	AINA08	PE4	142	126	1	98	100	78	62
	AINA09	PE5	141	125	128	97	99	77	61
	AINA10	PE6	140	124	127	96	98	76	60
	AINA11	PF0	139	123	126	95	97	75	59
	AINA12	PF1	138	122	125	94	96	74	58
	AINA13	PF2	137	121	124	93	95	-	-
	AINA14	PF3	136	120	123	92	94	-	-
	AINA15	PF4	135	119	122	91	93	-	-
	AINA16	PF5	134	118	121	90	92	-	-
	AINA17	PF6	133	117	120	-	-	-	-
	AINA18	PF7	132	116	119	-	-	-	-
	AINA19	PD4	131	-	-	-	-	-	-
AINA20	PD5	130	-	-	-	-	-	-	
Related reference manual	Function pin name	Port name	M3HQ (LQFP144)	M3HP (LQFP128-1414)	M3HP (LQFP128-1420)	M3HN (LQFP100)	M3HN (QFP100)	M3HM (LQFP80)	M3HL (LQFP64)
8-bit Digital to Analog Convertor	DAC0	PG0	9	9	12	9	11	8	8
	DAC1	PG1	10	10	13	10	12	9	9

Table 3.10 Signal Connection List: INT

Related reference manual	Function pin name	Port name	M3HQ (LQFP144)	M3HP (LQFP128-1414)	M3HP (LQFP128-1420)	M3HN (LQFP100)	M3HN (QFP100)	M3HM (LQFP80)	M3HL (LQFP64)
Exception	INT00	PC0	83	70	73	54	56	44	36
	INT01	PC1	84	71	74	55	57	45	37
	INT02	PC2	85	72	75	56	58	46	-
	INT03	PB1	38	34	37	27	29	22	18
	INT04	PJ4	108	95	98	75	77	60	48
	INT05	PK1	111	98	101	78	80	63	51
	INT06	PH3	74	64	67	52	54	42	34
	INT07	PA6	22	18	21	12	14	11	11
	INT08	PL3	50	44	47	37	39	29	24
	INT09	PM2	34	30	33	23	25	18	-
	INT10	PN3	100	87	90	67	69	52	41
	INT11	PA7	21	17	20	11	13	10	10
	INT12	PL4	51	45	48	38	40	30	25
	INT13	PK7	117	104	107	84	86	69	-
	INT14	PP3	118	105	108	85	87	70	57
	INT15	PM6	30	26	29	19	21	-	-
	INT16	PB7	44	40	43	33	35	-	-
	INT17	PV2	125	112	115	-	-	-	-
	INT18	PV3	126	113	116	-	-	-	-
	INT19	PH4	76	66	69	-	-	-	-
	INT20	PH5	77	67	70	-	-	-	-
	INT21	PH6	78	68	71	-	-	-	-
	INT22	PH7	79	69	72	-	-	-	-
	INT23	PT0	62	52	55	-	-	-	-
	INT24	PT1	61	51	54	-	-	-	-
	INT25	PT2	60	50	53	-	-	-	-
	INT26	PT3	59	49	52	-	-	-	-
	INT27	PG2	15	11	14	-	-	-	-
	INT28	PG3	16	12	15	-	-	-	-
	INT29	PT7	55	-	-	-	-	-	-
	INT30	PU0	45	-	-	-	-	-	-
	INT31	PU1	46	-	-	-	-	-	-
	INT32	PF3	136	120	123	92	94	-	-
INT33	PF2	137	121	124	93	95	-	-	

Table 3.11 Signal Connection List: A-PMD/A-ENC32/TRGSEL/REM/RTC

Related reference manual	Function pin name	Port name	M3HQ (LQFP144)	M3HP (LQFP128-1414)	M3HP (LQFP128-1420)	M3HN (LQFP100)	M3HN (QFP100)	M3HM (LQFP80)	M3HL (LQFP64)
Advanced Programmable Motor Control Circuit	UO0	PJ0	104	91	94	71	73	56	44
	XO0	PJ1	105	92	95	72	74	57	45
	VO0	PJ2	106	93	96	73	75	58	46
	YO0	PJ3	107	94	97	74	76	59	47
	WO0	PJ4	108	95	98	75	77	60	48
	ZO0	PJ5	109	96	99	76	78	61	49
	EMG0	PK0	110	97	100	77	79	62	50
	OVV0	PK1	111	98	101	78	80	63	51
	PMD0DBG	PP6	121	108	111	88	90	73	-
Advanced Encoder Input Circuit (32-bit)	ENC0A	PA0	28	24	27	18	20	17	15
	ENC0B	PA1	27	23	26	17	19	16	14
	ENC0Z	PA2	26	22	25	16	18	15	13
Related reference manual	Function pin name	Port name	M3HQ (LQFP144)	M3HP (LQFP128-1414)	M3HP (LQFP128-1420)	M3HN (LQFP100)	M3HN (QFP100)	M3HM (LQFP80)	M3HL (LQFP64)
Product Information (Trigger Selector)	TRGIN0	PB1	38	34	37	27	29	22	18
	TRGIN1	PA3	25	21	24	15	17	14	12
	TRGIN2	PN3	100	87	90	67	69	52	41
Related reference manual	Function pin name	Port name	M3HQ (LQFP144)	M3HP (LQFP128-1414)	M3HP (LQFP128-1420)	M3HN (LQFP100)	M3HN (QFP100)	M3HM (LQFP80)	M3HL (LQFP64)
Remote Control Signal preprocessor	RXIN0	PB1	38	34	37	27	29	22	18
Related reference manual	Function pin name	Port name	M3HQ (LQFP144)	M3HP (LQFP128-1414)	M3HP (LQFP128-1420)	M3HN (LQFP100)	M3HN (QFP100)	M3HM (LQFP80)	M3HL (LQFP64)
Real Time Clock	RTCOUT	PC2	85	72	75	56	58	46	-

Table 3.12 Signal Connection List: DLCD

Related reference manual	Function pin name	Port name	M3HQ (LQFP144)	M3HP (LQFP128-1414)	M3HP (LQFP128-1420)	M3HN (LQFP100)	M3HN (QFP100)	M3HM (LQFP80)	M3HL (LQFP64)
LCD Display Control Circuit	DCOM0	PC3	86	73	76	57	59	47	-
	DCOM1	PC2	85	72	75	56	58	46	-
	DCOM2	PC1	84	71	74	55	57	45	-
	DCOM3	PC0	83	70	73	54	56	44	-
	SEG00	PV3	126	113	116	-	-	-	-
	SEG01	PV2	125	112	115	-	-	-	-
	SEG02	PV1	124	111	114	-	-	-	-
	SEG03	PV0	123	110	113	-	-	-	-
	SEG04	PP7	122	109	112	89	91	-	-
	SEG05	PP6	121	108	111	88	90	73	-
	SEG06	PP5	120	107	110	87	89	72	-
	SEG07	PP4	119	106	109	86	88	71	-
	SEG08	PP3	118	105	108	85	87	70	-
	SEG09	PK7	117	104	107	84	86	69	-
	SEG10	PK6	116	103	106	83	85	68	-
	SEG11	PK5	115	102	105	82	84	67	-
	SEG12	PK4	114	101	104	81	83	66	-
	SEG13	PK3	113	100	103	80	82	65	-
	SEG14	PK2	112	99	102	79	81	64	-
	SEG15	PK1	111	98	101	78	80	63	-
	SEG16	PK0	110	97	100	77	79	62	-
	SEG17	PJ5	109	96	99	76	78	61	-
	SEG18	PJ4	108	95	98	75	77	60	-
	SEG19	PJ3	107	94	97	74	76	59	-
	SEG20	PJ2	106	93	96	73	75	58	-
	SEG21	PJ1	105	92	95	72	74	57	-
	SEG22	PJ0	104	91	94	71	73	56	-
	SEG23	PN0	103	90	93	70	72	55	-
	SEG24	PN1	102	89	92	69	71	54	-
	SEG25	PN2	101	88	91	68	70	53	-
	SEG26	PN3	100	87	90	67	69	52	-
	SEG27	PN4	99	86	89	66	68	51	-
	SEG28	PN5	98	85	88	65	67	-	-
	SEG29	PR7	97	84	87	-	-	-	-
	SEG30	PR6	96	83	86	-	-	-	-
SEG31	PR5	95	82	85	-	-	-	-	
SEG32	PR4	94	81	84	-	-	-	-	
SEG33	PR3	93	80	83	64	66	-	-	
SEG34	PR2	92	79	82	63	65	-	-	
SEG35	PR1	91	78	81	62	64	-	-	

Table 3.13 Signal Connection List: DLCD/ JTAG/SW/TRACE/Control Pin/IO

Related reference manual	Function pin name	Port name	M3HQ (LQFP144)	M3HP (LQFP128-1414)	M3HP (LQFP128-1420)	M3HN (LQFP100)	M3HN (QFP100)	M3HM (LQFP80)	M3HL (LQFP64)
LCD Display Control Circuit	SEG36	PR0	90	77	80	61	63	-	-
	SEG37	PC6	89	76	79	60	62	50	-
	SEG38	PC5	88	75	78	59	61	49	-
	SEG39	PC4	87	74	77	58	60	48	-
Related reference manual	Function pin name	Port name	M3HQ (LQFP144)	M3HP (LQFP128-1414)	M3HP (LQFP128-1420)	M3HN (LQFP100)	M3HN (QFP100)	M3HM (LQFP80)	M3HL (LQFP64)
Debug Interface	TMS	PL4	51	45	48	38	40	30	25
	TCK	PL3	50	44	47	37	39	29	24
	TDO	PL2	49	43	46	36	38	28	23
	TDI	PL1	48	42	45	35	37	27	22
	TRST_N	PL0	47	41	44	34	36	26	21
	SWDIO	PL4	51	45	48	38	40	30	25
	SWCLK	PL3	50	44	47	37	39	29	24
	SWV	PL2	49	43	46	36	38	28	23
	TRACECLK	PM0	36	32	35	25	27	20	-
	TRACEDATA0	PM1	35	31	34	24	26	19	-
	TRACEDATA1	PM2	34	30	33	23	25	18	-
	TRACEDATA2	PM3	33	29	32	22	24	-	-
TRACEDATA3	PM4	32	28	31	21	23	-	-	
Related reference manual	Function pin name	Port name	M3HQ (LQFP144)	M3HP (LQFP128-1414)	M3HP (LQFP128-1420)	M3HN (LQFP100)	M3HN (QFP100)	M3HM (LQFP80)	M3HL (LQFP64)
Clock Control and Operation Mode	SCOUT	PB0	37	33	36	26	28	21	17
	X1	PH0	70	60	63	48	50	38	30
	X2	PH1	71	61	64	49	51	39	31
	XT1	PH2	73	63	66	51	53	41	33
	XT2	PH3	74	64	67	52	54	42	34
	EHCLKIN	PH0	70	60	63	48	50	38	30
Flash Memory	BOOT_N	PB0	37	33	36	26	28	21	17
Related reference manual	Function pin name	Port name	M3HQ (LQFP144)	M3HP (LQFP128-1414)	M3HP (LQFP128-1420)	M3HN (LQFP100)	M3HN (QFP100)	M3HM (LQFP80)	M3HL (LQFP64)
Input Output Port	N/A	PM7	29	25	28	-	-	-	-
		PU2	14	-	-	-	-	-	-
		PU3	13	-	-	-	-	-	-
		PU4	12	-	-	-	-	-	-
		PU5	11	-	-	-	-	-	-
		PV4	127	-	-	-	-	-	-

4. Registers

The following registers should be set appropriately to use the ports.

Each register is 32 bits. The configuration of the register depends on the port count and its function assignment.

"x" and "n" in the following table show a port name and a function number, respectively.

Register name	Type	Setting value	Description
[PxDATA] Data Register	R/W	0 or 1	Read from and write to a port.
[PxCR] Output Control Register	R/W	0: Output disabled 1: Output enabled	Output control
[PxFRn] Function Register n	R/W	0: PORT 1: Function	Function setting When this register is set to "1", the assigned function becomes available. Each function assigned to a port has its own function register. If multiple functions are assigned to one port, only one function should be enabled.
[PxOD] Open-Drain Control Register	R/W	0: CMOS 1: Open-drain	Programmable open drain control The programmable open-drain is a pseudo open-drain. An output buffer is disabled when the output data is 1, which is set by [PxOD] = 1.
[PxPUP] Pull-up Control Register	R/W	0: Pull-up disabled 1: Pull-up enabled	Programmable pull-up control
[PxPDN] Pull-down Control Register	R/W	0: Pull-down disabled 1: Pull-down enabled	Programmable pull-down control
[PxIE] Input Control Register	R/W	0: Input disabled 1: Input enabled	Input control It takes up to 100ns that an external data is reflected on [PxDATA] after the [PxIE] is enabled.

4.1. List of Register

When the bit which is assigned to no functions is read, 0 is returned. The write to the bit is ignored.

Table 4.1 Ports Base Address

Peripheral function	Channel/unit	Base address	
Input/output ports	PA	-	0x400C0000
	PB	-	0x400C0100
	PC	-	0x400C0200
	PD	-	0x400C0300
	PE	-	0x400C0400
	PF	-	0x400C0500
	PG	-	0x400C0600
	PH	-	0x400C0700
	PJ	-	0x400C0800
	PK	-	0x400C0900
	PL	-	0x400C0A00
	PM	-	0x400C0B00
	PN	-	0x400C0C00
	PP	-	0x400C0D00
	PR	-	0x400C0E00
	PT	-	0x400C0F00
PU	-	0x400C1000	
PV	-	0x400C1100	

Table 4.2 Register List (1/4)

Register name	Address (Base+)	Port A	Port B	Port C	Port D	Port E
Data Register	0x0000	[PADATA]	[PBDATA]	[PCDATA]	[PDDATA]	[PEDATA]
Output Control Register	0x0004	[PACR]	[PBCR]	[PCCR]	[PDCR]	[PECR]
Function Register 1	0x0008	[PAFR1]	[PBFR1]	[PCFR1]	-	-
Function Register 2	0x000C	[PAFR2]	[PBFR2]	[PCFR2]	-	-
Function Register 3	0x0010	[PAFR3]	[PBFR3]	[PCFR3]	-	-
Function Register 4	0x0014	[PAFR4]	[PBFR4]	[PCFR4]	-	-
Function Register 5	0x0018	[PAFR5]	[PBFR5]	[PCFR5]	-	-
Function Register 6	0x001C	[PAFR6]	[PBFR6]	[PCFR6]	-	-
Open-Drain Control Register	0x0028	[PAOD]	[PBOD]	[PCOD]	[PDOD]	[PEOD]
Pull-up Control Register	0x002C	[PAPUP]	[PBPUP]	[PCPUP]	[PDPUP]	[PEPUP]
Pull-down Control Register	0x0030	[PAPDN]	[PBPDN]	[PCPDN]	[PDPDN]	[PEPDN]
Input Control Register	0x0038	[PAIE]	[PBIE]	[PCIE]	[PDIE]	[PEIE]

Note: Do not access the addresses described as "-"

Table 4.3 Register List (2/4)

Register name	Address (Base+)	Port F	Port G	Port H	Port J	Port K
Data Register	0x0000	[PFDATA]	[PGDATA]	[PHDATA]	[PJDATA]	[PKDATA]
Output Control Register	0x0004	[PFCR]	[PGCR]	[PHCR]	[PJCR]	[PKCR]
Function Register 1	0x0008	-	[PGFR1]	[PHFR1]	[PJFR1]	[PKFR1]
Function Register 2	0x000C	-	[PGFR2]	-	[PJFR2]	[PKFR2]
Function Register 3	0x0010	-	[PGFR3]	-	[PJFR3]	[PKFR3]
Function Register 4	0x0014	-	[PGFR4]	-	[PJFR4]	[PKFR4]
Function Register 5	0x0018	-	-	-	[PJFR5]	[PKFR5]
Function Register 6	0x001C	-	-	-	[PJFR6]	[PKFR6]
Open-Drain Control Register	0x0028	[PFOD]	[PGOD]	[PHOD]	[PJOD]	[PKOD]
Pull-up Control Register	0x002C	[PFPUP]	[PGPUP]	[PHPUP]	[PJPUP]	[PKPUP]
Pull-down Control Register	0x0030	[PFPDN]	[PGPDN]	[PHPDN]	[PJPDN]	[PKPDN]
Input Control Register	0x0038	[PFIE]	[PGIE]	[PHIE]	[PJIE]	[PKIE]

Note: Do not access the addresses described as "-"

Table 4.4 Register List (3/4)

Register name	Address (Base+)	Port L	Port M	Port N	Port P	Port R
Data Register	0x0000	[PLDATA]	[PMDATA]	[PNDATA]	[PPDATA]	[PRDATA]
Output Control Register	0x0004	[PLCR]	[PMCR]	[PNCR]	[PPCR]	[PRCR]
Function Register 1	0x0008	[PLFR1]	[PMFR1]	[PNFR1]	[PPFR1]	[PRFR1]
Function Register 2	0x000C	[PLFR2]	[PMFR2]	[PNFR2]	[PPFR2]	[PRFR2]
Function Register 3	0x0010	[PLFR3]	[PMFR3]	[PNFR3]	[PPFR3]	[PRFR3]
Function Register 4	0x0014	[PLFR4]	[PMFR4]	[PNFR4]	[PPFR4]	[PRFR4]
Function Register 5	0x0018	[PLFR5]	[PMFR5]	[PNFR5]	-	-
Function Register 6	0x001C	-	[PMFR6]	[PNFR6]	[PPFR6]	[PRFR6]
Open-Drain Control Register	0x0028	[PLOD]	[PMOD]	[PNOD]	[PPOD]	[PROD]
Pull-up Control Register	0x002C	[PLPUP]	[PMPUP]	[PNPUP]	[PPPUP]	[PRPUP]
Pull-down Control Register	0x0030	[PLPDN]	[PMPDN]	[PNPDN]	[PPPDN]	[PRPDN]
Input Control Register	0x0038	[PLIE]	[PMIE]	[PNIE]	[PPIE]	[PRIE]

Note: Do not access the addresses described as "-"

Table 4.5 Register List (4/4)

Register name	Address (Base+)	Port T	Port U	Port V
Data Register	0x0000	[PTDATA]	[PUDATA]	[PVDATA]
Output Control Register	0x0004	[PTCR]	[PUCR]	[PVCR]
Function Register 1	0x0008	[PTFR1]	-	[PVFR1]
Function Register 2	0x000C	[PTFR2]	-	[PVFR2]
Function Register 3	0x0010	[PTFR3]	-	-
Function Register 4	0x0014	[PTFR4]	-	-
Function Register 5	0x0018	-	-	-
Function Register 6	0x001C	-	-	[PVFR6]
Open-Drain Control Register	0x0028	[PTOD]	[PUOD]	[PVOD]
Pull-up Control Register	0x002C	[PTPUP]	[PUPUP]	[PVPUP]
Pull-down Control Register	0x0030	[PTPDN]	[PUPDN]	[PVPDN]
Input Control Register	0x0038	[PTIE]	[PUIE]	[PVIE]

Note: Do not access the addresses described as "-"

4.2. List of Port Functions and Settings

It is explained about viewpoint of a port register setting table.

The column of $[PxFRn]$ shows the function register which should be set. When this register is set to "1", the corresponding function is enabled. (x is a port name and n is a function number.)

The bit in the N/A in the tables returns "0" when it is read. The write to the bit is ignored.

"0" or "1" in the tables shows the value which should be set. "0/1" means either value can be set.

PORT	Reset status Function	Input/Output	PORT Type	Control register						
				[PADATA]	[PACR]	[PAFRn]	[PAOD]	[PAPUP]	[PAPDN]	[PAIE]
PA0	After reset			0	0	0	0	0	0	0
	Input Port	Input		0/1	0	0	0/1	0/1	0/1	1
	Output Port	Output		0/1	1	0	0/1	0/1	0/1	0
	UT0TXDB	Output	FTU1	0/1	1	[PAFR1]	0/1	0/1	0/1	0
	TSPI0SCK	Input	FTU1	0/1	0	[PAFR3]	0/1	0/1	0/1	1
	T32A00OUTA	Output	FTU1	0/1	1	[PAFR4]	0/1	0/1	0/1	0
	T32A00OUTC	Output	FTU1	0/1	1	[PAFR5]	0/1	0/1	0/1	0
ENC0A	Input	FTU1	0/1	0	[PAFR6]	0/1	0/1	0/1	1	
PA7	After reset			0	0	0	0	0	0	0
	Input Port	Input		0/1	0	0	0/1	0/1	0/1	1
	Output Port	Output		0/1	1	0	0/1	0/1	0/1	0
	INT11	Input	FTU4	0/1	0	0	0/1	0/1	0/1	1
	UT3TXDA	Output	FTU1	0/1	1	[PAFR1]	0/1	0/1	0/1	0
UT3RXD	Input	FTU1	0/1	0	[PAFR2]	0/1	0/1	0/1	1	

$[PxFRn]$	Pin					
	ENC0A	T32A00OUTC	T32A00OUTA	TSPI0SCK	UT0TXDB	Input Port Output Port
[PAFR1]<bit0>	0	0	0	0	1	0
[PAFR3]<bit0>	0	0	0	1	0	0
[PAFR4]<bit0>	0	0	1	0	0	0
[PAFR5]<bit0>	0	1	0	0	0	0
[PAFR6]<bit0>	1	0	0	0	0	0

Note: The register value after reset is the initial value before the clock is enabled.

4.2.1. Setting of Using Alternated Pin

To use the alternated pins as peripheral function output pins, set the peripheral function ($[PxFRn]$ <bit $m \geq 1$) that uses the function register and enable output control register ($[PxCR]$ <bit $m \geq 1$), then set the peripheral functions. If output is enabled before setting the function register, the data register value of the port is output until the function register is set.

To use the alternated pins as input pins of the peripheral function, set the input control register of the port ($[PxIE]$ <bit $m \geq 1$) and set the peripheral function that uses the function register ($[PxFRn]$ <bit $m \geq 1$), then set the peripheral functions.

To use peripheral functions such as I²C, set the input control register of the port ($[PxIE]$ <bit $m \geq 1$), set the peripheral function ($[PxFRn]$ <bit $m \geq 1$) and set the output control register to output enable ($[PxCR]$ <bit $m \geq 1$), then set the peripheral function.

- When multiple functions are assigned to the same pin, please choose only one function for usage.
- When same function is assigned to multiple pins, please the function use exclusively.

4.2.2. PORT A

Table 4.6 Port A Registers Setting

PORT	Reset status	Input/output	PORT type	Control register						
	Function			[PADATA]	[PACR]	[PAFRn]	[PAOD]	[PAPUP]	[PAPDN]	[PAIE]
PA0	After reset			0	0	0	0	0	0	0
	Input Port	Input		0/1	0	0	0/1	0/1	0/1	1
	Output Port	Output		0/1	1	0	0/1	0/1	0/1	0
	UT0TXDB	Output	FTU1	0/1	1	[PAFR1]	0/1	0/1	0/1	0
	TSPIO SCK	Input	FTU1	0/1	0	[PAFR3]	0/1	0/1	0/1	1
		Output		0/1	1	0/1	0/1	0/1	0	
	T32A00OUTA	Output	FTU1	0/1	1	[PAFR4]	0/1	0/1	0/1	0
	T32A00OUTC	Output	FTU1	0/1	1	[PAFR5]	0/1	0/1	0/1	0
ENCOA	Input	FTU1	0/1	0	[PAFR6]	0/1	0/1	0/1	1	
PA1	After reset			0	0	0	0	0	0	0
	Input Port	Input		0/1	0	0	0/1	0/1	0/1	1
	Output Port	Output		0/1	1	0	0/1	0/1	0/1	0
	UT0TXDA	Output	FTU1	0/1	1	[PAFR1]	0/1	0/1	0/1	0
	UT0RXD	Input	FTU1	0/1	0	[PAFR2]	0/1	0/1	0/1	1
	TSPIOTXD	Output	FTU2	0/1	1	[PAFR3]	0/1	0/1	0/1	0
	T32A00INA0	Input	FTU1	0/1	0	[PAFR4]	0/1	0/1	0/1	1
	T32A00INCO	Input	FTU1	0/1	0	[PAFR5]	0/1	0/1	0/1	1
ENCOB	Input	FTU1	0/1	0	[PAFR6]	0/1	0/1	0/1	1	
PA2	After reset			0	0	0	0	0	0	0
	Input Port	Input		0/1	0	0	0/1	0/1	0/1	1
	Output Port	Output		0/1	1	0	0/1	0/1	0/1	0
	UT0RXD	Input	FTU1	0/1	0	[PAFR1]	0/1	0/1	0/1	1
	UT0TXDA	Output	FTU1	0/1	1	[PAFR2]	0/1	0/1	0/1	0
	TSPIORXD	Input	FTU1	0/1	0	[PAFR3]	0/1	0/1	0/1	1
	T32A00INA1	Input	FTU1	0/1	0	[PAFR4]	0/1	0/1	0/1	1
	T32A00INC1	Input	FTU1	0/1	0	[PAFR5]	0/1	0/1	0/1	1
ENCOZ	Input	FTU1	0/1	0	[PAFR6]	0/1	0/1	0/1	1	
PA3	After reset			0	0	0	0	0	0	0
	Input Port	Input		0/1	0	0	0/1	0/1	0/1	1
	Output Port	Output		0/1	1	0	0/1	0/1	0/1	0
	TSPIOCSIN	Input	FTU1	0/1	0	[PAFR2]	0/1	0/1	0/1	1
	TSPIOCS0	Output	FTU1	0/1	1	[PAFR3]	0/1	0/1	0/1	0
	T32A00OUTB	Output	FTU1	0/1	1	[PAFR4]	0/1	0/1	0/1	0
	TRGIN1	Input	FTU1	0/1	0	[PAFR6]	0/1	0/1	0/1	1
PA4	After reset			0	0	0	0	0	0	0
	Input Port	Input		0/1	0	0	0/1	0/1	0/1	1
	Output Port	Output		0/1	1	0	0/1	0/1	0/1	0
	I2C1SCL	I/O	FTU1	0/1	1	[PAFR1]	1	0/1	0/1	1
	EI2C1SCL	I/O	FTU12	0/1	1	[PAFR2]	1	0/1	0/1	1
	TSPIOCS1	Output	FTU1	0/1	1	[PAFR3]	0/1	0/1	0/1	0
	T32A00INB0	Input	FTU1	0/1	0	[PAFR4]	0/1	0/1	0/1	1
PA5	After reset			0	0	0	0	0	0	0
	Input Port	Input		0/1	0	0	0/1	0/1	0/1	1
	Output Port	Output		0/1	1	0	0/1	0/1	0/1	0
	I2C1SDA	I/O	FTU1	0/1	1	[PAFR1]	1	0/1	0/1	1
	EI2C1SDA	I/O	FTU12	0/1	1	[PAFR2]	1	0/1	0/1	1
	T32A00INB1	Input	FTU1	0/1	0	[PAFR4]	0/1	0/1	0/1	1
PA6	After reset			0	0	0	0	0	0	0
	Input Port	Input		0/1	0	0	0/1	0/1	0/1	1
	Output Port	Output		0/1	1	0	0/1	0/1	0/1	0
	INT07	Input	FTU4	0/1	0	0	0/1	0/1	0/1	1
	UT3RXD	Input	FTU1	0/1	0	[PAFR1]	0/1	0/1	0/1	1
	UT3TXDA	Output	FTU1	0/1	1	[PAFR2]	0/1	0/1	0/1	0
PA7	After reset			0	0	0	0	0	0	0
	Input Port	Input		0/1	0	0	0/1	0/1	0/1	1
	Output Port	Output		0/1	1	0	0/1	0/1	0/1	0
	INT11	Input	FTU4	0/1	0	0	0/1	0/1	0/1	1
	UT3TXDA	Output	FTU1	0/1	1	[PAFR1]	0/1	0/1	0/1	0
	UT3RXD	Input	FTU1	0/1	0	[PAFR2]	0/1	0/1	0/1	1

4.2.3. PORT B

Table 4.7 Port B Registers Setting

PORT	Reset status	Input/output	PORT type	Control register						
	Function			[PBDATA]	[PBCR]	[PBFRn]	[PBOD]	[PBPUP]	[PBPDN]	[PBIE]
PB0	During reset (BOOT_N)	Input	FTU6	0	0	0	0	0 (Note)	0	N/A (Note)
	After reset			0	0	0	0	0	0	N/A
	Output Port	Output		0/1	1	0	0/1	0/1	0/1	N/A
	T32A01OUTA	Output	FTU1	0/1	1	[PBFR4]	0/1	0/1	0/1	N/A
	T32A01OUTC	Output	FTU1	0/1	1	[PBFR5]	0/1	0/1	0/1	N/A
	SCOUT	Output	FTU1	0/1	1	[PBFR6]	0/1	0/1	0/1	N/A
PB1	After reset			0	0	0	0	0	0	0
	Input Port	Input		0/1	0	0	0/1	0/1	0/1	1
	Output Port	Output		0/1	1	0	0/1	0/1	0/1	0
	INT03	Input	FTU4	0/1	0	0	0/1	0/1	0/1	1
	RXIN0	Input	FTU1	0/1	0	[PBFR1]	0/1	0/1	0/1	1
	T32A01INA0	Input	FTU1	0/1	0	[PBFR4]	0/1	0/1	0/1	1
	T32A01INC0	Input	FTU1	0/1	0	[PBFR5]	0/1	0/1	0/1	1
	TRGIN0	Input	FTU1	0/1	0	[PBFR6]	0/1	0/1	0/1	1
PB2	After reset			0	0	0	0	0	0	0
	Input Port	Input		0/1	0	0	0/1	0/1	0/1	1
	Output Port	Output		0/1	1	0	0/1	0/1	0/1	0
	UT2TXDA	Output	FTU1	0/1	1	[PBFR1]	0/1	0/1	0/1	0
	UT2RXD	Input	FTU1	0/1	0	[PBFR2]	0/1	0/1	0/1	1
	TSPI1SCK	Input	FTU1	0/1	0	[PBFR3]	0/1	0/1	0/1	1
		Output		0/1	1		0/1	0/1	0/1	0
	T32A01INA1	Input	FTU1	0/1	0	[PBFR4]	0/1	0/1	0/1	1
T32A01INC1	Input	FTU1	0/1	0	[PBFR5]	0/1	0/1	0/1	1	
PB3	After reset			0	0	0	0	0	0	0
	Input Port	Input		0/1	0	0	0/1	0/1	0/1	1
	Output Port	Output		0/1	1	0	0/1	0/1	0/1	0
	UT2RXD	Input	FTU1	0/1	0	[PBFR1]	0/1	0/1	0/1	1
	UT2TXDA	Output	FTU1	0/1	1	[PBFR2]	0/1	0/1	0/1	0
	TSPI1TXD	Output	FTU2	0/1	1	[PBFR3]	0/1	0/1	0/1	0
	T32A01OUTB	Output	FTU1	0/1	1	[PBFR4]	0/1	0/1	0/1	0
PB4	After reset			0	0	0	0	0	0	0
	Input Port	Input		0/1	0	0	0/1	0/1	0/1	1
	Output Port	Output		0/1	1	0	0/1	0/1	0/1	0
	UT2CTS_N	Input	FTU1	0/1	0	[PBFR1]	0/1	0/1	0/1	1
	UT2RTS_N	Output	FTU1	0/1	1	[PBFR2]	0/1	0/1	0/1	0
	TSPI1RXD	Input	FTU1	0/1	0	[PBFR3]	0/1	0/1	0/1	1
	T32A01INB0	Input	FTU1	0/1	0	[PBFR4]	0/1	0/1	0/1	1
PB5	After reset			0	0	0	0	0	0	0
	Input Port	Input		0/1	0	0	0/1	0/1	0/1	1
	Output Port	Output		0/1	1	0	0/1	0/1	0/1	0
	UT2RTS_N	Output	FTU1	0/1	1	[PBFR1]	0/1	0/1	0/1	0
	UT2CTS_N	Input	FTU1	0/1	0	[PBFR2]	0/1	0/1	0/1	1
	TSPI1CS0	Output	FTU1	0/1	1	[PBFR3]	0/1	0/1	0/1	0
	T32A01INB1	Input	FTU1	0/1	0	[PBFR4]	0/1	0/1	0/1	1
	TSPI1CSIN	Input	FTU1	0/1	0	[PBFR5]	0/1	0/1	0/1	1
PB6	After reset			0	0	0	0	0	0	0
	Input Port	Input		0/1	0	0	0/1	0/1	0/1	1
	Output Port	Output		0/1	1	0	0/1	0/1	0/1	0
	TSPI1CS1	Output	FTU1	0/1	1	[PBFR3]	0/1	0/1	0/1	0
PB7	After reset			0	0	N/A	0	0	0	0
	Input Port	Input		0/1	0	N/A	0/1	0/1	0/1	1
	Output Port	Output		0/1	1	N/A	0/1	0/1	0/1	0
	INT16	Input	FTU4	0/1	0	N/A	0/1	0/1	0/1	1

Note: During the reset period by the reset pin (RESET_N), the state of the BOOT_N pin can be input to PB0 with pull-up enabled and input enabled.

4.2.4. PORT C

Table 4.8 Port C Registers Setting

PORT	Reset status	Input/output	PORT type	Control register						
	Function			[PCDATA]	[PCCR]	[PCFRn]	[PCOD]	[PCPUP]	[PCPDN]	[PCIE]
PC0	After reset			0	0	0	0	0	0	0
	Input Port	Input		0/1	0	0	0/1	0/1	0/1	1
	Output Port	Output		0/1	1	0	0/1	0/1	0/1	0
	INT00	Input	FTU4	0/1	0	0	0/1	0/1	0/1	1
	I2C0SCL	I/O	FTU1	0/1	1	[PCFR1]	1	0/1	0/1	1
	EI2C0SCL	I/O	FTU12	0/1	1	[PCFR2]	1	0/1	0/1	1
	T32A02OUTA	Output	FTU1	0/1	1	[PCFR3]	0/1	0/1	0/1	0
	T32A02OUTC	Output	FTU1	0/1	1	[PCFR4]	0/1	0/1	0/1	0
DCOM3	Output	FTU1	0/1	1	[PCFR6]	0	0	0	0	
PC1	After reset			0	0	0	0	0	0	0
	Input Port	Input		0/1	0	0	0/1	0/1	0/1	1
	Output Port	Output		0/1	1	0	0/1	0/1	0/1	0
	INT01	Input	FTU4	0/1	0	0	0/1	0/1	0/1	1
	I2C0SDA	I/O	FTU1	0/1	1	[PCFR1]	1	0/1	0/1	1
	EI2C0SDA	I/O	FTU12	0/1	1	[PCFR2]	1	0/1	0/1	1
	T32A02INA0	Input	FTU1	0/1	0	[PCFR3]	0/1	0/1	0/1	1
	T32A02INC0	Input	FTU1	0/1	0	[PCFR4]	0/1	0/1	0/1	1
DCOM2	Output	FTU1	0/1	1	[PCFR6]	0	0	0	0	
PC2	After reset			0	0	0	0	0	0	0
	Input Port	Input		0/1	0	0	0/1	0/1	0/1	1
	Output Port	Output		0/1	1	0	0/1	0/1	0/1	0
	INT02	Input	FTU4	0/1	0	0	0/1	0/1	0/1	1
	UT4TXDB	Output	FTU1	0/1	1	[PCFR1]	0/1	0/1	0/1	0
	T32A02INA1	Input	FTU1	0/1	0	[PCFR3]	0/1	0/1	0/1	1
	T32A02INC1	Input	FTU1	0/1	0	[PCFR4]	0/1	0/1	0/1	1
	RTCOUT	Output	FTU1	0/1	1	[PCFR5]	0/1	0/1	0/1	0
DCOM1	Output	FTU1	0/1	1	[PCFR6]	0	0	0	0	
PC3	After reset			0	0	0	0	0	0	0
	Input Port	Input		0/1	0	0	0/1	0/1	0/1	1
	Output Port	Output		0/1	1	0	0/1	0/1	0/1	0
	UT4TXDA	Output	FTU1	0/1	1	[PCFR1]	0/1	0/1	0/1	0
	UT4RXD	Input	FTU1	0/1	0	[PCFR2]	0/1	0/1	0/1	1
	T32A02OUTB	Output	FTU1	0/1	1	[PCFR3]	0/1	0/1	0/1	0
	DCOM0	Output	FTU1	0/1	1	[PCFR6]	0	0	0	0
PC4	After reset			0	0	0	0	0	0	0
	Input Port	Input		0/1	0	0	0/1	0/1	0/1	1
	Output Port	Output		0/1	1	0	0/1	0/1	0/1	0
	UT4RXD	Input	FTU1	0/1	0	[PCFR1]	0/1	0/1	0/1	1
	UT4TXDA	Output	FTU1	0/1	1	[PCFR2]	0/1	0/1	0/1	0
	T32A02INB0	Input	FTU1	0/1	0	[PCFR3]	0/1	0/1	0/1	1
	SEG39	Output	FTU1	0/1	1	[PCFR6]	0	0	0	0
PC5	After reset			0	0	0	0	0	0	0
	Input Port	Input		0/1	0	0	0/1	0/1	0/1	1
	Output Port	Output		0/1	1	0	0/1	0/1	0/1	0
	UT4CTS_N	Input	FTU1	0/1	0	[PCFR1]	0/1	0/1	0/1	1
	UT4RTS_N	Output	FTU1	0/1	1	[PCFR2]	0/1	0/1	0/1	0
	T32A02INB1	Input	FTU1	0/1	0	[PCFR3]	0/1	0/1	0/1	1
	SEG38	Output	FTU1	0/1	1	[PCFR6]	0	0	0	0
PC6	After reset			0	0	0	0	0	0	0
	Input Port	Input		0/1	0	0	0/1	0/1	0/1	1
	Output Port	Output		0/1	1	0	0/1	0/1	0/1	0
	UT4RTS_N	Output	FTU1	0/1	1	[PCFR1]	0/1	0/1	0/1	0
	UT4CTS_N	Input	FTU1	0/1	0	[PCFR2]	0/1	0/1	0/1	1
	SEG37	Output	FTU1	0/1	1	[PCFR6]	0	0	0	0

4.2.5. PORT D

Table 4.9 Port D Registers Setting

PORT	Reset status	Input/output	PORT type	Control register						
	Function			[PDDATA]	[PDCR]	[PDFRn]	[PDOD]	[PDPUP]	[PDPDN]	[PDIE]
PD0	After reset			0	0	N/A	0	0	0	0
	Input Port	Input		0/1	0	N/A	0/1	0/1	0/1	1
	Output Port	Output		0/1	1	N/A	0/1	0/1	0/1	0
	AINA00 (Note)	Input	FTU5	0/1	0	N/A	0/1	0	0	0
PD1	After reset			0	0	N/A	0	0	0	0
	Input Port	Input		0/1	0	N/A	0/1	0/1	0/1	1
	Output Port	Output		0/1	1	N/A	0/1	0/1	0/1	0
	AINA01 (Note)	Input	FTU5	0/1	0	N/A	0/1	0	0	0
PD2	After reset			0	0	N/A	0	0	0	0
	Input Port	Input		0/1	0	N/A	0/1	0/1	0/1	1
	Output Port	Output		0/1	1	N/A	0/1	0/1	0/1	0
	AINA02 (Note)	Input	FTU5	0/1	0	N/A	0/1	0	0	0
PD3	After reset			0	0	N/A	0	0	0	0
	Input Port	Input		0/1	0	N/A	0/1	0/1	0/1	1
	Output Port	Output		0/1	1	N/A	0/1	0/1	0/1	0
	AINA03 (Note)	Input	FTU5	0/1	0	N/A	0/1	0	0	0
PD4	After reset			0	0	N/A	0	0	0	0
	Input Port	Input		0/1	0	N/A	0/1	0/1	0/1	1
	Output Port	Output		0/1	1	N/A	0/1	0/1	0/1	0
	AINA19 (Note)	Input	FTU5	0/1	0	N/A	0/1	0	0	0
PD5	After reset			0	0	N/A	0	0	0	0
	Input Port	Input		0/1	0	N/A	0/1	0/1	0/1	1
	Output Port	Output		0/1	1	N/A	0/1	0/1	0/1	0
	AINA20 (Note)	Input	FTU5	0/1	0	N/A	0/1	0	0	0

Note: When using analog input (AINAx), [PDCR] should be output disable "0", [PDIE] should be input disable "0", [PDPUP] should be pull-up disable "0" and [PDPDN] should be pull-down disable "0".

4.2.6. PORT E

Table 4.10 Port E Registers Setting

PORT	Reset status	Input/output	PORT type	Control register						
	Function			[PEDATA]	[PECR]	[PEFRn]	[PEOD]	[PEPUP]	[PEPDN]	[PEIE]
PE0	After reset			0	0	N/A	0	0	0	0
	Input Port	Input		0/1	0	N/A	0/1	0/1	0/1	1
	Output Port	Output		0/1	1	N/A	0/1	0/1	0/1	0
	AINA04 (Note)	Input	FTU5	0/1	0	N/A	0/1	0	0	0
PE1	After reset			0	0	N/A	0	0	0	0
	Input Port	Input		0/1	0	N/A	0/1	0/1	0/1	1
	Output Port	Output		0/1	1	N/A	0/1	0/1	0/1	0
	AINA05 (Note)	Input	FTU5	0/1	0	N/A	0/1	0	0	0
PE2	After reset			0	0	N/A	0	0	0	0
	Input Port	Input		0/1	0	N/A	0/1	0/1	0/1	1
	Output Port	Output		0/1	1	N/A	0/1	0/1	0/1	0
	AINA06 (Note)	Input	FTU5	0/1	0	N/A	0/1	0	0	0
PE3	After reset			0	0	N/A	0	0	0	0
	Input Port	Input		0/1	0	N/A	0/1	0/1	0/1	1
	Output Port	Output		0/1	1	N/A	0/1	0/1	0/1	0
	AINA07 (Note)	Input	FTU5	0/1	0	N/A	0/1	0	0	0
PE4	After reset			0	0	N/A	0	0	0	0
	Input Port	Input		0/1	0	N/A	0/1	0/1	0/1	1
	Output Port	Output		0/1	1	N/A	0/1	0/1	0/1	0
	AINA08 (Note)	Input	FTU5	0/1	0	N/A	0/1	0	0	0
PE5	After reset			0	0	N/A	0	0	0	0
	Input Port	Input		0/1	0	N/A	0/1	0/1	0/1	1
	Output Port	Output		0/1	1	N/A	0/1	0/1	0/1	0
	AINA09 (Note)	Input	FTU5	0/1	0	N/A	0/1	0	0	0
PE6	After reset			0	0	N/A	0	0	0	0
	Input Port	Input		0/1	0	N/A	0/1	0/1	0/1	1
	Output Port	Output		0/1	1	N/A	0/1	0/1	0/1	0
	AINA10 (Note)	Input	FTU5	0/1	0	N/A	0/1	0	0	0

Note: When using analog input (AINAx), [PECR] should be output disable "0", [PEIE] should be input disable "0", [PEPUP] should be pull-up disable "0" and [PEPDN] should be pull-down disable "0".

4.2.7. PORT F

Table 4.11 Port F Registers Setting

PORT	Reset status	Input/output	PORT type	Control register						
	Function			[PFDATA]	[PFCR]	[PFFRn]	[PFOD]	[PFPUP]	[PFPDN]	[PFIE]
PF0	After reset			0	0	N/A	0	0	0	0
	Input Port	Input		0/1	0	N/A	0/1	0/1	0/1	1
	Output Port	Output		0/1	1	N/A	0/1	0/1	0/1	0
	AINA11 (Note)	Input	FTU5	0/1	0	N/A	0/1	0	0	0
PF1	After reset			0	0	N/A	0	0	0	0
	Input Port	Input		0/1	0	N/A	0/1	0/1	0/1	1
	Output Port	Output		0/1	1	N/A	0/1	0/1	0/1	0
	AINA12 (Note)	Input	FTU5	0/1	0	N/A	0/1	0	0	0
PF2	After reset			0	0	N/A	0	0	0	0
	Input Port	Input		0/1	0	N/A	0/1	0/1	0/1	1
	Output Port	Output		0/1	1	N/A	0/1	0/1	0/1	0
	INT33	Input	FTU4	0/1	0	N/A	0/1	0/1	0/1	1
	AINA13 (Note)	Input	FTU5	0/1	0	N/A	0/1	0	0	0
PF3	After reset			0	0	N/A	0	0	0	0
	Input Port	Input		0/1	0	N/A	0/1	0/1	0/1	1
	Output Port	Output		0/1	1	N/A	0/1	0/1	0/1	0
	INT32	Input	FTU4	0/1	0	N/A	0/1	0/1	0/1	1
	AINA14 (Note)	Input	FTU5	0/1	0	N/A	0/1	0	0	0
PF4	After reset			0	0	N/A	0	0	0	0
	Input Port	Input		0/1	0	N/A	0/1	0/1	0/1	1
	Output Port	Output		0/1	1	N/A	0/1	0/1	0/1	0
	AINA15 (Note)	Input	FTU5	0/1	0	N/A	0/1	0	0	0
PF5	After reset			0	0	N/A	0	0	0	0
	Input Port	Input		0/1	0	N/A	0/1	0/1	0/1	1
	Output Port	Output		0/1	1	N/A	0/1	0/1	0/1	0
	AINA16 (Note)	Input	FTU5	0/1	0	N/A	0/1	0	0	0
PF6	After reset			0	0	N/A	0	0	0	0
	Input Port	Input		0/1	0	N/A	0/1	0/1	0/1	1
	Output Port	Output		0/1	1	N/A	0/1	0/1	0/1	0
	AINA17 (Note)	Input	FTU5	0/1	0	N/A	0/1	0	0	0
PF7	After reset			0	0	N/A	0	0	0	0
	Input Port	Input		0/1	0	N/A	0/1	0/1	0/1	1
	Output Port	Output		0/1	1	N/A	0/1	0/1	0/1	0
	AINA18 (Note)	Input	FTU5	0/1	0	N/A	0/1	0	0	0

Note: When using analog input (AINAx), [PFCR] should be output disable "0", [PFIE] should be input disable "0", [PFPUP] should be pull-up disable "0" and [PFPDN] should be pull-down disable "0".

4.2.8. PORT G

Table 4.12 Port G Registers Setting

PORT	Reset status	Input/output	PORT type	Control register						
	Function			[PGDATA]	[PGCR]	[PGFRn]	[PGOD]	[PGPUP]	[PGPDN]	[PGIE]
PG0	After reset			0	0	N/A	0	0	0	0
	Input Port	Input		0/1	0	N/A	0/1	0/1	0/1	1
	Output Port	Output		0/1	1	N/A	0/1	0/1	0/1	0
	DAC0 (Note)	Output	FTU13	0/1	0	N/A	0/1	0	0	0
PG1	After reset			0	0	N/A	0	0	0	0
	Input Port	Input		0/1	0	N/A	0/1	0/1	0/1	1
	Output Port	Output		0/1	1	N/A	0/1	0/1	0/1	0
	DAC1 (Note)	Output	FTU13	0/1	0	N/A	0/1	0	0	0
PG2	After reset			0	0	0	0	0	0	0
	Input Port	Input		0/1	0	0	0/1	0/1	0/1	1
	Output Port	Output		0/1	1	0	0/1	0/1	0/1	0
	INT27	Input	FTU4	0/1	0	0	0/1	0/1	0/1	1
	UT3RXD	Input	FTU1	0/1	0	[PGFR1]	0/1	0/1	0/1	1
	UT3TXDA	Output	FTU1	0/1	1	[PGFR2]	0/1	0/1	0/1	0
	T32A07OUTA	Output	FTU1	0/1	1	[PGFR3]	0/1	0/1	0/1	0
T32A07OUTC	Output	FTU1	0/1	1	[PGFR4]	0/1	0/1	0/1	0	
PG3	After reset			0	0	0	0	0	0	0
	Input Port	Input		0/1	0	0	0/1	0/1	0/1	1
	Output Port	Output		0/1	1	0	0/1	0/1	0/1	0
	INT28	Input	FTU4	0/1	0	0	0/1	0/1	0/1	1
	UT3TXDA	Output	FTU1	0/1	1	[PGFR1]	0/1	0/1	0/1	0
	UT3RXD	Input	FTU1	0/1	0	[PGFR2]	0/1	0/1	0/1	1
	T32A07INA0	Input	FTU1	0/1	0	[PGFR3]	0/1	0/1	0/1	1
T32A07INC0	Input	FTU1	0/1	0	[PGFR4]	0/1	0/1	0/1	1	
PG4	After reset			0	0	0	0	0	0	0
	Input Port	Input		0/1	0	0	0/1	0/1	0/1	1
	Output Port	Output		0/1	1	0	0/1	0/1	0/1	0
	UT3TXDB	Output	FTU1	0/1	1	[PGFR1]	0/1	0/1	0/1	0
	T32A07INA1	Input	FTU1	0/1	0	[PGFR3]	0/1	0/1	0/1	1
	T32A07INC1	Input	FTU1	0/1	0	[PGFR4]	0/1	0/1	0/1	1
PG5	After reset			0	0	0	0	0	0	0
	Input Port	Input		0/1	0	0	0/1	0/1	0/1	1
	Output Port	Output		0/1	1	0	0/1	0/1	0/1	0
	T32A07OUTB	Output	FTU1	0/1	1	[PGFR3]	0/1	0/1	0/1	0
PG6	After reset			0	0	0	0	0	0	0
	Input Port	Input		0/1	0	0	0/1	0/1	0/1	1
	Output Port	Output		0/1	1	0	0/1	0/1	0/1	0
	T32A07INB0	Input	FTU1	0/1	0	[PGFR3]	0	0/1	0/1	1
PG7	After reset			0	0	0	0	0	0	0
	Input Port	Input		0/1	0	0	0/1	0/1	0/1	1
	Output Port	Output		0/1	1	0	0/1	0/1	0/1	0
	T32A07INB1	Input	FTU1	0/1	0	[PGFR3]	0/1	0/1	0/1	1

Note: When using analog output (DACx), [PGCR] should be output disable "0", [PGIE] should be input disable "0", [PGPUP] should be pull-up disable "0" and [PGPDN] should be pull-down disable "0".

4.2.9. PORT H

Table 4.13 Port H Registers Setting

PORT	Reset status	Input/output	PORT type	Control register						
	Function			[PHDATA]	[PHCR]	[PHFRn]	[PHOD]	[PHPUP]	[PHPDN]	[PHIE]
PH0	After reset			0	N/A	N/A	N/A	N/A	0	0
	Input Port	Input		0/1	N/A	N/A	N/A	N/A	0/1	1
	X1	Input	FTU10	0/1	N/A	N/A	N/A	N/A	0	0
	EHCLKIN	Input	FTU10	0/1	N/A	N/A	N/A	N/A	0	0/1
PH1	After reset			0	N/A	N/A	N/A	N/A	0	0
	Input Port	Input		0/1	N/A	N/A	N/A	N/A	0/1	1
	X2	Output	FTU10	0/1	N/A	N/A	N/A	N/A	0	0
PH2	After reset			0	N/A	N/A	N/A	N/A	0	0
	Input Port	Input		0/1	N/A	N/A	N/A	N/A	0/1	1
	XT1	Input	FTU11	0/1	N/A	N/A	N/A	N/A	0	0
PH3	After reset			0	N/A	N/A	N/A	N/A	0	0
	Input Port	Input		0/1	N/A	N/A	N/A	N/A	0/1	1
	XT2	Output	FTU11	0/1	N/A	N/A	N/A	N/A	0	0
	INT06	Input	FTU11	0/1	N/A	N/A	N/A	N/A	0/1	1
PH4	After reset			0	0	0	0	0	0	0
	Input Port	Input		0/1	0	0	0/1	0/1	0/1	1
	Output Port	Output		0/1	1	0	0/1	0/1	0/1	0
	INT19	Input	FTU4	0/1	0	0	0/1	0/1	0/1	1
	TSPI4SCK	Input	FTU1	0/1	0	[PHFR1]	0/1	0/1	0/1	1
Output		0/1		1	0/1		0/1	0/1	0	
PH5	After reset			0	0	0	0	0	0	0
	Input Port	Input		0/1	0	0	0/1	0/1	0/1	1
	Output Port	Output		0/1	1	0	0/1	0/1	0/1	0
	INT20	Input	FTU4	0/1	0	0	0/1	0/1	0/1	1
	TSPI4TXD	Output	FTU2	0/1	1	[PHFR1]	0/1	0/1	0/1	0
PH6	After reset			0	0	0	0	0	0	0
	Input Port	Input		0/1	0	0	0/1	0/1	0/1	1
	Output Port	Output		0/1	1	0	0/1	0/1	0/1	0
	INT21	Input	FTU4	0/1	0	0	0/1	0/1	0/1	1
	TSPI4RXD	Input	FTU1	0/1	0	[PHFR1]	0/1	0/1	0/1	1
PH7	After reset			0	0	N/A	0	0	0	0
	Input Port	Input		0/1	0	N/A	0/1	0/1	0/1	1
	Output Port	Output		0/1	1	N/A	0/1	0/1	0/1	0
	INT22	Input	FTU4	0/1	0	N/A	0/1	0/1	0/1	1

4.2.10. PORT J

Table 4.14 Port J Registers Setting

PORT	Reset status	Input/output	PORT type	Control register						
	Function			[PJDATA]	[PJCR]	[PJFRn]	[PJOD]	[PJPUP]	[PJPDN]	[PJIE]
PJ0	After reset			0	0	0	0	0	0	0
	Input Port	Input		0/1	0	0	0/1	0/1	0/1	1
	Output Port	Output		0/1	1	0	0/1	0/1	0/1	0
	UT1TXDB	Output	FTU1	0/1	1	[PJFR1]	0/1	0/1	0/1	0
	T32A03OUTA	Output	FTU1	0/1	1	[PJFR3]	0/1	0/1	0/1	0
	T32A03OUTC	Output	FTU1	0/1	1	[PJFR4]	0/1	0/1	0/1	0
	UO0	Output	FTU2	0/1	1	[PJFR5]	0/1	0/1	0/1	0
SEG22	Output	FTU1	0/1	1	[PJFR6]	0	0	0	0	
PJ1	After reset			0	0	0	0	0	0	0
	Input Port	Input		0/1	0	0	0/1	0/1	0/1	1
	Output Port	Output		0/1	1	0	0/1	0/1	0/1	0
	UT1TXDA	Output	FTU1	0/1	1	[PJFR1]	0/1	0/1	0/1	0
	UT1RXD	Input	FTU1	0/1	0	[PJFR2]	0/1	0/1	0/1	1
	T32A03INA0	Input	FTU1	0/1	0	[PJFR3]	0/1	0/1	0/1	1
	T32A03INC0	Input	FTU1	0/1	0	[PJFR4]	0/1	0/1	0/1	1
XO0	Output	FTU2	0/1	1	[PJFR5]	0/1	0/1	0/1	0	
SEG21	Output	FTU1	0/1	1	[PJFR6]	0	0	0	0	
PJ2	After reset			0	0	0	0	0	0	0
	Input Port	Input		0/1	0	0	0/1	0/1	0/1	1
	Output Port	Output		0/1	1	0	0/1	0/1	0/1	0
	UT1RXD	Input	FTU1	0/1	0	[PJFR1]	0/1	0/1	0/1	1
	UT1TXDA	Output	FTU1	0/1	1	[PJFR2]	0/1	0/1	0/1	0
	T32A03INA1	Input	FTU1	0/1	0	[PJFR3]	0/1	0/1	0/1	1
	T32A03INC1	Input	FTU1	0/1	0	[PJFR4]	0/1	0/1	0/1	1
VO0	Output	FTU2	0/1	1	[PJFR5]	0/1	0/1	0/1	0	
SEG20	Output	FTU1	0/1	1	[PJFR6]	0	0	0	0	
PJ3	After reset			0	0	0	0	0	0	0
	Input Port	Input		0/1	0	0	0/1	0/1	0/1	1
	Output Port	Output		0/1	1	0	0/1	0/1	0/1	0
	UT1CTS_N	Input	FTU1	0/1	0	[PJFR1]	0/1	0/1	0/1	1
	UT1RTS_N	Output	FTU1	0/1	1	[PJFR2]	0/1	0/1	0/1	0
	T32A03OUTB	Output	FTU1	0/1	1	[PJFR3]	0/1	0/1	0/1	0
	YO0	Output	FTU2	0/1	1	[PJFR5]	0/1	0/1	0/1	0
SEG19	Output	FTU1	0/1	1	[PJFR6]	0	0	0	0	
PJ4	After reset			0	0	0	0	0	0	0
	Input Port	Input		0/1	0	0	0/1	0/1	0/1	1
	Output Port	Output		0/1	1	0	0/1	0/1	0/1	0
	INT04	Input	FTU4	0/1	0	0	0/1	0/1	0/1	1
	UT1RTS_N	Output	FTU1	0/1	1	[PJFR1]	0/1	0/1	0/1	0
	UT1CTS_N	Input	FTU1	0/1	0	[PJFR2]	0/1	0/1	0/1	1
	T32A03INB0	Input	FTU1	0/1	0	[PJFR3]	0/1	0/1	0/1	1
WO0	Output	FTU2	0/1	1	[PJFR5]	0/1	0/1	0/1	0	
SEG18	Output	FTU1	0/1	1	[PJFR6]	0	0	0	0	
PJ5	After reset			0	0	0	0	0	0	0
	Input Port	Input		0/1	0	0	0/1	0/1	0/1	1
	Output Port	Output		0/1	1	0	0/1	0/1	0/1	0
	T32A03INB1	Input	FTU1	0/1	0	[PJFR3]	0/1	0/1	0/1	1
	ZO0	Output	FTU2	0/1	1	[PJFR5]	0/1	0/1	0/1	0
SEG17	Output	FTU1	0/1	1	[PJFR6]	0	0	0	0	

4.2.11. PORT K

Table 4.15 Port K Registers Setting

PORT	Reset status	Input/output	PORT type	Control register						
	Function			[PKDATA]	[PKCR]	[PKFRn]	[PKOD]	[PKPUP]	[PKPDN]	[PKIE]
PK0	After reset			0	0	0	0	0	0	0
	Input Port	Input		0/1	0	0	0/1	0/1	0/1	1
	Output Port	Output		0/1	1	0	0/1	0/1	0/1	0
	UT1TXDB	Output	FTU1	0/1	1	[PKFR1]	0/1	0/1	0/1	0
	EMG0	Input	FTU1	0/1	0	[PKFR5]	0/1	0/1	0/1	1
	SEG16	Output	FTU1	0/1	1	[PKFR6]	0	0	0	0
PK1	After reset			0	0	0	0	0	0	0
	Input Port	Input		0/1	0	0	0/1	0/1	0/1	1
	Output Port	Output		0/1	1	0	0/1	0/1	0/1	0
	INT05	Input	FTU4	0/1	0	0	0/1	0/1	0/1	1
	UT1TXDA	Output	FTU1	0/1	1	[PKFR1]	0/1	0/1	0/1	0
	UT1RXD	Input	FTU1	0/1	0	[PKFR2]	0/1	0/1	0/1	1
	OVV0	Input	FTU1	0/1	0	[PKFR5]	0/1	0/1	0/1	1
	SEG15	Output	FTU1	0/1	1	[PKFR6]	0	0	0	0
PK2	After reset			0	0	0	0	0	0	0
	Input Port	Input		0/1	0	0	0/1	0/1	0/1	1
	Output Port	Output		0/1	1	0	0/1	0/1	0/1	0
	UT1RXD	Input	FTU1	0/1	0	[PKFR1]	0/1	0/1	0/1	1
	UT1TXDA	Output	FTU1	0/1	1	[PKFR2]	0/1	0/1	0/1	0
	T32A04OUTA	Output	FTU1	0/1	1	[PKFR3]	0/1	0/1	0/1	0
	T32A04OUTC	Output	FTU1	0/1	1	[PKFR4]	0/1	0/1	0/1	0
	SEG14	Output	FTU1	0/1	1	[PKFR6]	0	0	0	0
PK3	After reset			0	0	0	0	0	0	0
	Input Port	Input		0/1	0	0	0/1	0/1	0/1	1
	Output Port	Output		0/1	1	0	0/1	0/1	0/1	0
	UT1CTS_N	Input	FTU1	0/1	0	[PKFR1]	0/1	0/1	0/1	1
	UT1RTS_N	Output	FTU1	0/1	1	[PKFR2]	0/1	0/1	0/1	0
	T32A04INA0	Input	FTU1	0/1	0	[PKFR3]	0/1	0/1	0/1	1
	T32A04INC0	Input	FTU1	0/1	0	[PKFR4]	0/1	0/1	0/1	1
	SEG13	Output	FTU1	0/1	1	[PKFR6]	0	0	0	0
PK4	After reset			0	0	0	0	0	0	0
	Input Port	Input		0/1	0	0	0/1	0/1	0/1	1
	Output Port	Output		0/1	1	0	0/1	0/1	0/1	0
	UT1RTS_N	Output	FTU1	0/1	1	[PKFR1]	0/1	0/1	0/1	0
	UT1CTS_N	Input	FTU1	0/1	0	[PKFR2]	0/1	0/1	0/1	1
	T32A04INA1	Input	FTU1	0/1	0	[PKFR3]	0/1	0/1	0/1	1
	T32A04INC1	Input	FTU1	0/1	0	[PKFR4]	0/1	0/1	0/1	1
	SEG12	Output	FTU1	0/1	1	[PKFR6]	0	0	0	0
PK5	After reset			0	0	0	0	0	0	0
	Input Port	Input		0/1	0	0	0/1	0/1	0/1	1
	Output Port	Output		0/1	1	0	0/1	0/1	0/1	0
	UT6RXD	Input	FTU1	0/1	0	[PKFR1]	0/1	0/1	0/1	1
	UT6TXDA	Output	FTU1	0/1	1	[PKFR2]	0/1	0/1	0/1	0
	T32A04OUTB	Output	FTU1	0/1	1	[PKFR3]	0/1	0/1	0/1	0
	SEG11	Output	FTU1	0/1	1	[PKFR6]	0	0	0	0
PK6	After reset			0	0	0	0	0	0	0
	Input Port	Input		0/1	0	0	0/1	0/1	0/1	1
	Output Port	Output		0/1	1	0	0/1	0/1	0/1	0
	UT6TXDA	Output	FTU1	0/1	1	[PKFR1]	0/1	0/1	0/1	0
	UT6RXD	Input	FTU1	0/1	0	[PKFR2]	0/1	0/1	0/1	1
	T32A04INB0	Input	FTU1	0/1	0	[PKFR3]	0/1	0/1	0/1	1
	SEG10	Output	FTU1	0/1	1	[PKFR6]	0	0	0	0

PORT	Reset status	Input/output	PORT type	Control register						
	Function			[PKDATA]	[PKCR]	[PKFRn]	[PKOD]	[PKPUP]	[PKPDN]	[PKIE]
PK7	After reset			0	0	0	0	0	0	0
	Input Port	Input		0/1	0	0	0/1	0/1	0/1	1
	Output Port	Output		0/1	1	0	0/1	0/1	0/1	0
	INT13	Input	FTU4	0/1	0	0	0/1	0/1	0/1	1
	UT6TXDB	Output	FTU1	0/1	1	[PKFR1]	0/1	0/1	0/1	0
	T32A04INB1	Input	FTU1	0/1	0	[PKFR3]	0/1	0/1	0/1	1
	SEG09	Output	FTU1	0/1	1	[PKFR6]	0	0	0	0

4.2.12. PORT L

Table 4.16 Port L Registers Setting

PORT	Reset status	Input/output	PORT type	Control register						
	Function			[PLDATA]	[PLCR]	[PLFRn]	[PLOD]	[PLPUP]	[PLPDN]	[PLIE]
PL0	After reset (TRST_N)	Input	FTU3	0	0	[PLFR5]	0	1	0	1
	Input Port	Input		0/1	0	0	0/1	0/1	0/1	1
	Output Port	Output		0/1	1	0	0/1	0/1	0/1	0
	UT2TXDA	Output	FTU1	0/1	1	[PLFR1]	0/1	0/1	0/1	0
	UT2RXD	Input	FTU1	0/1	0	[PLFR2]	0/1	0/1	0/1	1
	I2C2SCL	I/O	FTU1	0/1	1	[PLFR3]	1	0/1	0/1	1
	EI2C2SCL	I/O	FTU12	0/1	1	[PLFR4]	1	0/1	0/1	1
PL1	After reset (TDI)	Input	FTU1	0	0	[PLFR5]	0	1	0	1
	Input Port	Input		0/1	0	0	0/1	0/1	0/1	1
	Output Port	Output		0/1	1	0	0/1	0/1	0/1	0
	UT2RXD	Input	FTU1	0/1	0	[PLFR1]	0/1	0/1	0/1	1
	UT2TXDA	Output	FTU1	0/1	1	[PLFR2]	0/1	0/1	0/1	0
	I2C2SDA	I/O	FTU1	0/1	1	[PLFR3]	1	0/1	0/1	1
	EI2C2SDA	I/O	FTU12	0/1	1	[PLFR4]	1	0/1	0/1	1
PL2	After reset (TDO/SWV)	Output	FTU2	0	1(Note)	[PLFR5]	0	0	0	0
	Input Port	Input		0/1	0	0	0/1	0/1	0/1	1
	Output Port	Output		0/1	1	0	0/1	0/1	0/1	0
	UT2CTS_N	Input	FTU1	0/1	0	[PLFR1]	0/1	0/1	0/1	1
	UT2RTS_N	Output	FTU1	0/1	1	[PLFR2]	0/1	0/1	0/1	0
	T32A06OUTB	Output	FTU1	0/1	1	[PLFR3]	0/1	0/1	0/1	0
PL3	After reset (TCK/SWCLK)	Input	FTU1	0	0	[PLFR5]	0	0	1	1
	Input Port	Input		0/1	0	0	0/1	0/1	0/1	1
	Output Port	Output		0/1	1	0	0/1	0/1	0/1	0
	INT08	Input	FTU4	0/1	0	0	0/1	0/1	0/1	1
	UT2RTS_N	Output	FTU1	0/1	1	[PLFR1]	0/1	0/1	0/1	0
	UT2CTS_N	Input	FTU1	0/1	0	[PLFR2]	0/1	0/1	0/1	1
	T32A06INB0	Input	FTU1	0/1	0	[PLFR3]	0/1	0/1	0/1	1
PL4	After reset (TMS/SWDIO)	I/O	FTU2	0	1(Note)	[PLFR5]	0	1	0	1
	Input Port	Input		0/1	0	0	0/1	0/1	0/1	1
	Output Port	Output		0/1	1	0	0/1	0/1	0/1	0
	INT12	Input	FTU4	0/1	0	0	0/1	0/1	0/1	1
	T32A06INB1	Input	FTU1	0/1	0	[PLFR3]	0/1	0/1	0/1	1
PL5	After reset			0	0	0	0	0	0	0
	Input Port	Input		0/1	0	0	0/1	0/1	0/1	1
	Output Port	Output		0/1	1	0	0/1	0/1	0/1	0
	T32A06OUTA	Output	FTU1	0/1	1	[PLFR3]	0/1	0/1	0/1	0
	T32A06OUTC	Output	FTU1	0/1	1	[PLFR4]	0/1	0/1	0/1	0
PL6	After reset			0	0	0	0	0	0	0
	Input Port	Input		0/1	0	0	0/1	0/1	0/1	1
	Output Port	Output		0/1	1	0	0/1	0/1	0/1	0
	T32A06INA0	Input	FTU1	0/1	0	[PLFR3]	0/1	0/1	0/1	1
	T32A06INC0	Input	FTU1	0/1	0	[PLFR4]	0/1	0/1	0/1	1
PL7	After reset			0	0	0	0	0	0	0
	Input Port	Input		0/1	0	0	0/1	0/1	0/1	1
	Output Port	Output		0/1	1	0	0/1	0/1	0/1	0
	T32A06INA1	Input	FTU1	0/1	0	[PLFR3]	0/1	0/1	0/1	1
	T32A06INC1	Input	FTU1	0/1	0	[PLFR4]	0/1	0/1	0/1	1

Note: When receive the command from TOOL, it becomes output

4.2.13. PORT M

Table 4.17 Port M Registers Setting

PORT	Reset status	Input/output	PORT type	Control register						
	Function			[PMDATA]	[PMCR]	[PMFRn]	[PMOD]	[PMPUP]	[PMPDN]	[PMIE]
PM0	After reset			0	0	0	0	0	0	0
	Input Port	Input		0/1	0	0	0/1	0/1	0/1	1
	Output Port	Output		0/1	1	0	0/1	0/1	0/1	0
	UT0TXDB	Output	FTU1	0/1	1	[PMFR1]	0/1	0/1	0/1	0
	TSPI0SCK	Input	FTU1	0/1	0	[PMFR3]	0/1	0/1	0/1	1
		Output	FTU1	0/1	1		0/1	0/1	0/1	0
	T32A00OUTA	Output	FTU1	0/1	1	[PMFR4]	0/1	0/1	0/1	0
	T32A00OUTC	Output	FTU1	0/1	1	[PMFR5]	0/1	0/1	0/1	0
TRACECLK	Output	FTU1	0/1	1	[PMFR6]	0/1	0/1	0/1	0	
PM1	After reset			0	0	0	0	0	0	0
	Input Port	Input		0/1	0	0	0/1	0/1	0/1	1
	Output Port	Output		0/1	1	0	0/1	0/1	0/1	0
	UT0TXDA	Output	FTU1	0/1	1	[PMFR1]	0/1	0/1	0/1	0
	UT0RXD	Input	FTU1	0/1	0	[PMFR2]	0/1	0/1	0/1	1
	TSPI0TXD	Output	FTU2	0/1	1	[PMFR3]	0/1	0/1	0/1	0
	T32A00INA0	Input	FTU1	0/1	0	[PMFR4]	0/1	0/1	0/1	1
	T32A00INC0	Input	FTU1	0/1	0	[PMFR5]	0/1	0/1	0/1	1
TRACEDATA0	Output	FTU1	0/1	1	[PMFR6]	0/1	0/1	0/1	0	
PM2	After reset			0	0	0	0	0	0	0
	Input Port	Input		0/1	0	0	0/1	0/1	0/1	1
	Output Port	Output		0/1	1	0	0/1	0/1	0/1	0
	INT09	Input	FTU4	0/1	0	0	0/1	0/1	0/1	1
	UT0RXD	Input	FTU1	0/1	0	[PMFR1]	0/1	0/1	0/1	1
	UT0TXDA	Output	FTU1	0/1	1	[PMFR2]	0/1	0/1	0/1	0
	TSPIORXD	Input	FTU1	0/1	0	[PMFR3]	0/1	0/1	0/1	1
	T32A00INA1	Input	FTU1	0/1	0	[PMFR4]	0/1	0/1	0/1	1
T32A00INC1	Input	FTU1	0/1	0	[PMFR5]	0/1	0/1	0/1	1	
TRACEDATA1	Output	FTU1	0/1	1	[PMFR6]	0/1	0/1	0/1	0	
PM3	After reset			0	0	0	0	0	0	0
	Input Port	Input		0/1	0	0	0/1	0/1	0/1	1
	Output Port	Output		0/1	1	0	0/1	0/1	0/1	0
	UT0CTS_N	Input	FTU1	0/1	0	[PMFR1]	0/1	0/1	0/1	1
	UT0RTS_N	Output	FTU1	0/1	1	[PMFR2]	0/1	0/1	0/1	0
	TSPI0CS0	Output	FTU1	0/1	1	[PMFR3]	0/1	0/1	0/1	0
	T32A00OUTB	Output	FTU1	0/1	1	[PMFR4]	0/1	0/1	0/1	0
	TSPI0CSIN	Input	FTU1	0/1	0	[PMFR5]	0/1	0/1	0/1	1
TRACEDATA2	Output	FTU1	0/1	1	[PMFR6]	0/1	0/1	0/1	0	
PM4	After reset			0	0	0	0	0	0	0
	Input Port	Input		0/1	0	0	0/1	0/1	0/1	1
	Output Port	Output		0/1	1	0	0/1	0/1	0/1	0
	UT0RTS_N	Output	FTU1	0/1	1	[PMFR1]	0/1	0/1	0/1	0
	UT0CTS_N	Input	FTU1	0/1	0	[PMFR2]	0/1	0/1	0/1	1
	TSPI0CS1	Output	FTU1	0/1	1	[PMFR3]	0/1	0/1	0/1	0
	T32A00INB0	Input	FTU1	0/1	0	[PMFR4]	0/1	0/1	0/1	1
	TRACEDATA3	Output	FTU1	0/1	1	[PMFR6]	0/1	0/1	0/1	0
PM5	After reset			0	0	0	0	0	0	0
	Input Port	Input		0/1	0	0	0/1	0/1	0/1	1
	Output Port	Output		0/1	1	0	0/1	0/1	0/1	0
	T32A00INB1	Input	FTU1	0/1	0	[PMFR4]	0/1	0/1	0/1	1
PM6	After reset			0	0	N/A	0	0	0	0
	Input Port	Input		0/1	0	N/A	0/1	0/1	0/1	1
	Output Port	Output		0/1	1	N/A	0/1	0/1	0/1	0
	INT15	Input	FTU4	0/1	0	N/A	0/1	0/1	0/1	1
PM7	After reset			0	0	N/A	0	0	0	0
	Input Port	Input		0/1	0	N/A	0/1	0/1	0/1	1
	Output Port	Output		0/1	1	N/A	0/1	0/1	0/1	0

4.2.14. PORT N

Table 4.18 Port N Registers Setting

PORT	Reset status	Input/output	PORT type	Control register						
	Function			[PNDATA]	[PNCR]	[PNFRn]	[PNOD]	[PNPUP]	[PNPDN]	[PNIE]
PN0	After reset			0	0	0	0	0	0	0
	Input Port	Input		0/1	0	0	0/1	0/1	0/1	1
	Output Port	Output		0/1	1	0	0/1	0/1	0/1	0
	UT5RTS_N	Output	FTU1	0/1	1	[PNFR1]	0/1	0/1	0/1	0
	UT5CTS_N	Input	FTU1	0/1	0	[PNFR2]	0/1	0/1	0/1	1
	T32A05OUTA	Output	FTU1	0/1	1	[PNFR3]	0/1	0/1	0/1	0
	T32A05OUTC	Output	FTU1	0/1	1	[PNFR4]	0/1	0/1	0/1	0
	SEG23	Output	FTU1	0/1	1	[PNFR6]	0	0	0	0
PN1	After reset			0	0	0	0	0	0	0
	Input Port	Input		0/1	0	0	0/1	0/1	0/1	1
	Output Port	Output		0/1	1	0	0/1	0/1	0/1	0
	UT5CTS_N	Input	FTU1	0/1	0	[PNFR1]	0/1	0/1	0/1	1
	UT5RTS_N	Output	FTU1	0/1	1	[PNFR2]	0/1	0/1	0/1	0
	T32A05INA0	Input	FTU1	0/1	0	[PNFR3]	0/1	0/1	0/1	1
	T32A05INC0	Input	FTU1	0/1	0	[PNFR4]	0/1	0/1	0/1	1
	SEG24	Output	FTU1	0/1	1	[PNFR6]	0	0	0	0
PN2	After reset			0	0	0	0	0	0	0
	Input Port	Input		0/1	0	0	0/1	0/1	0/1	1
	Output Port	Output		0/1	1	0	0/1	0/1	0/1	0
	UT5RXD	Input	FTU1	0/1	0	[PNFR1]	0/1	0/1	0/1	1
	UT5TXDA	Output	FTU1	0/1	1	[PNFR2]	0/1	0/1	0/1	0
	T32A05INA1	Input	FTU1	0/1	0	[PNFR3]	0/1	0/1	0/1	1
	T32A05INC1	Input	FTU1	0/1	0	[PNFR4]	0/1	0/1	0/1	1
	SEG25	Output	FTU1	0/1	1	[PNFR6]	0	0	0	0
PN3	After reset			0	0	0	0	0	0	0
	Input Port	Input		0/1	0	0	0/1	0/1	0/1	1
	Output Port	Output		0/1	1	0	0/1	0/1	0/1	0
	INT10	Input	FTU4	0/1	0	0	0/1	0/1	0/1	1
	UT5TXDA	Output	FTU1	0/1	1	[PNFR1]	0/1	0/1	0/1	0
	UT5RXD	Input	FTU1	0/1	0	[PNFR2]	0/1	0/1	0/1	1
	T32A05OUTB	Output	FTU1	0/1	1	[PNFR3]	0/1	0/1	0/1	0
	TRGIN2	Input	FTU1	0/1	0	[PNFR5]	0/1	0/1	0/1	1
SEG26	Output	FTU1	0/1	1	[PNFR6]	0	0	0	0	
PN4	After reset			0	0	0	0	0	0	0
	Input Port	Input		0/1	0	0	0/1	0/1	0/1	1
	Output Port	Output		0/1	1	0	0/1	0/1	0/1	0
	UT5TXDB	Output	FTU1	0/1	1	[PNFR1]	0/1	0/1	0/1	0
	T32A05INB0	Input	FTU1	0/1	0	[PNFR3]	0/1	0/1	0/1	1
	SEG27	Output	FTU1	0/1	1	[PNFR6]	0	0	0	0
PN5	After reset			0	0	0	0	0	0	0
	Input Port	Input		0/1	0	0	0/1	0/1	0/1	1
	Output Port	Output		0/1	1	0	0/1	0/1	0/1	0
	T32A05INB1	Input	FTU1	0/1	0	[PNFR3]	0/1	0/1	0/1	1
	SEG28	Output	FTU1	0/1	1	[PNFR6]	0	0	0	0

4.2.15. PORT P

Table 4.19 Port P Registers Setting

PORT	Reset status	Input/output	PORT type	Control register						
	Function			[PPDATA]	[PPCR]	[PPFRn]	[PPOD]	[PPPUP]	[PPPDN]	[PPIE]
PP0	After reset			0	0	0	0	0	0	0
	Input Port	Input		0/1	0	0	0/1	0/1	0/1	1
	Output Port	Output		0/1	1	0	0/1	0/1	0/1	0
	TSPI2SCK	Input	FTU1	0/1	0	[PPFR2]	0/1	0/1	0/1	1
		Output		0/1	1		0/1	0/1	0/1	0
	T32A01OUTA	Output	FTU1	0/1	1	[PPFR3]	0/1	0/1	0/1	0
T32A01OUTC	Output	FTU1	0/1	1	[PPFR4]	0/1	0/1	0/1	0	
PP1	After reset			0	0	0	0	0	0	0
	Input Port	Input		0/1	0	0	0/1	0/1	0/1	1
	Output Port	Output		0/1	1	0	0/1	0/1	0/1	0
	TSPI2TXD	Output	FTU2	0/1	1	[PPFR2]	0/1	0/1	0/1	0
	T32A01INA0	Input	FTU1	0/1	0	[PPFR3]	0/1	0/1	0/1	1
	T32A01INC0	Input	FTU1	0/1	0	[PPFR4]	0/1	0/1	0/1	1
PP2	After reset			0	0	0	0	0	0	0
	Input Port	Input		0/1	0	0	0/1	0/1	0/1	1
	Output Port	Output		0/1	1	0	0/1	0/1	0/1	0
	TSPI2RXD	Input	FTU1	0/1	0	[PPFR2]	0/1	0/1	0/1	1
	T32A01INA1	Input	FTU1	0/1	0	[PPFR3]	0/1	0/1	0/1	1
	T32A01INC1	Input	FTU1	0/1	0	[PPFR4]	0/1	0/1	0/1	1
PP3	After reset			0	0	0	0	0	0	0
	Input Port	Input		0/1	0	0	0/1	0/1	0/1	1
	Output Port	Output		0/1	1	0	0/1	0/1	0/1	0
	INT14	Input	FTU4	0/1	0	0	0/1	0/1	0/1	1
	TSPI3RXD	Input	FTU1	0/1	0	[PPFR1]	0/1	0/1	0/1	1
	SEG08	Output	FTU1	0/1	1	[PPFR6]	0	0	0	0
PP4	After reset			0	0	0	0	0	0	0
	Input Port	Input		0/1	0	0	0/1	0/1	0/1	1
	Output Port	Output		0/1	1	0	0/1	0/1	0/1	0
	TSPI3TXD	Output	FTU2	0/1	1	[PPFR1]	0/1	0/1	0/1	0
	SEG07	Output	FTU1	0/1	1	[PPFR6]	0	0	0	0
	PP5	After reset			0	0	0	0	0	0
Input Port		Input		0/1	0	0	0/1	0/1	0/1	1
Output Port		Output		0/1	1	0	0/1	0/1	0/1	0
TSPI3SCK		Input	FTU1	0/1	0	[PPFR1]	0/1	0/1	0/1	1
		Output		0/1	1		0/1	0/1	0/1	0
SEG06		Output	FTU1	0/1	1	[PPFR6]	0	0	0	0
PP6	After reset			0	0	0	0	0	0	0
	Input Port	Input		0/1	0	0	0/1	0/1	0/1	1
	Output Port	Output		0/1	1	0	0/1	0/1	0/1	0
	TSPI3CS0	Output	FTU1	0/1	1	[PPFR1]	0/1	0/1	0/1	0
	TSPI3CSIN	Input	FTU1	0/1	0	[PPFR2]	0/1	0/1	0/1	1
	PMD0DBG	Output	FTU1	0/1	1	[PPFR3]	0/1	0/1	0/1	0
	SEG05	Output	FTU1	0/1	1	[PPFR6]	0	0	0	0
PP7	After reset			0	0	0	0	0	0	0
	Input Port	Input		0/1	0	0	0/1	0/1	0/1	1
	Output Port	Output		0/1	1	0	0/1	0/1	0/1	0
	TSPI3CS1	Output	FTU1	0/1	1	[PPFR1]	0/1	0/1	0/1	0
	SEG04	Output	FTU1	0/1	1	[PPFR6]	0	0	0	0

4.2.16. PORT R

Table 4.20 Port R Registers Setting

PORT	Reset status	Input/output	PORT type	Control register						
	Function			[PRDATA]	[PRCR]	[PRFRn]	[PROD]	[PRPUP]	[PRPDN]	[PRIE]
PR0	After reset			0	0	0	0	0	0	0
	Input Port	Input		0/1	0	0	0/1	0/1	0/1	1
	Output Port	Output		0/1	1	0	0/1	0/1	0/1	0
	UT7RXD	Input	FTU1	0/1	0	[PRFR1]	0/1	0/1	0/1	1
	UT7TXDA	Output	FTU1	0/1	1	[PRFR2]	0/1	0/1	0/1	0
	T32A02OUTA	Output	FTU1	0/1	1	[PRFR3]	0/1	0/1	0/1	0
	T32A02OUTC	Output	FTU1	0/1	1	[PRFR4]	0/1	0/1	0/1	0
SEG36	Output	FTU1	0/1	1	[PRFR6]	0	0	0	0	
PR1	After reset			0	0	0	0	0	0	0
	Input Port	Input		0/1	0	0	0/1	0/1	0/1	1
	Output Port	Output		0/1	1	0	0/1	0/1	0/1	0
	UT7TXDA	Output	FTU1	0/1	1	[PRFR1]	0/1	0/1	0/1	0
	UT7RXD	Input	FTU1	0/1	0	[PRFR2]	0/1	0/1	0/1	1
	T32A02INA0	Input	FTU1	0/1	0	[PRFR3]	0/1	0/1	0/1	1
	T32A02INC0	Input	FTU1	0/1	0	[PRFR4]	0/1	0/1	0/1	1
SEG35	Output	FTU1	0/1	1	[PRFR6]	0	0	0	0	
PR2	After reset			0	0	0	0	0	0	0
	Input Port	Input		0/1	0	0	0/1	0/1	0/1	1
	Output Port	Output		0/1	1	0	0/1	0/1	0/1	0
	UT7TXDB	Output	FTU1	0/1	1	[PRFR1]	0/1	0/1	0/1	0
	T32A02INA1	Input	FTU1	0/1	0	[PRFR3]	0/1	0/1	0/1	1
	T32A02INC1	Input	FTU1	0/1	0	[PRFR4]	0/1	0/1	0/1	1
	SEG34	Output	FTU1	0/1	1	[PRFR6]	0	0	0	0
PR3	After reset			0	0	0	0	0	0	0
	Input Port	Input		0/1	0	0	0/1	0/1	0/1	1
	Output Port	Output		0/1	1	0	0/1	0/1	0/1	0
	SEG33	Output	FTU1	0/1	1	[PRFR6]	0	0	0	0
PR4	After reset			0	0	0	0	0	0	0
	Input Port	Input		0/1	0	0	0/1	0/1	0/1	1
	Output Port	Output		0/1	1	0	0/1	0/1	0/1	0
	SEG32	Output	FTU1	0/1	1	[PRFR6]	0	0	0	0
PR5	After reset			0	0	0	0	0	0	0
	Input Port	Input		0/1	0	0	0/1	0/1	0/1	1
	Output Port	Output		0/1	1	0	0/1	0/1	0/1	0
	SEG31	Output	FTU1	0/1	1	[PRFR6]	0	0	0	0
PR6	After reset			0	0	0	0	0	0	0
	Input Port	Input		0/1	0	0	0/1	0/1	0/1	1
	Output Port	Output		0/1	1	0	0/1	0/1	0/1	0
	SEG30	Output	FTU1	0/1	1	[PRFR6]	0	0	0	0
PR7	After reset			0	0	0	0	0	0	0
	Input Port	Input		0/1	0	0	0/1	0/1	0/1	1
	Output Port	Output		0/1	1	0	0/1	0/1	0/1	0
	SEG29	Output	FTU1	0/1	1	[PRFR6]	0	0	0	0

4.2.17. PORT T

Table 4.21 Port T Registers Setting

PORT	Reset status	Input/output	PORT type	Control register						
	Function			[PTDATA]	[PTCR]	[PTFRn]	[PTOD]	[PTPUP]	[PTPDN]	[PTIE]
PT0	After reset			0	0	0	0	0	0	0
	Input Port	Input		0/1	0	0	0/1	0/1	0/1	1
	Output Port	Output		0/1	1	0	0/1	0/1	0/1	0
	INT23	Input	FTU4	0/1	0	0	0/1	0/1	0/1	1
	I2C3SDA	I/O	FTU1	0/1	1	[PTFR1]	1	0/1	0/1	1
	TSPI2CS1	Output	FTU1	0/1	1	[PTFR2]	0/1	0/1	0/1	0
	EI2C3SDA	I/O	FTU12	0/1	1	[PTFR4]	1	0/1	0/1	1
PT1	After reset			0	0	0	0	0	0	0
	Input Port	Input		0/1	0	0	0/1	0/1	0/1	1
	Output Port	Output		0/1	1	0	0/1	0/1	0/1	0
	INT24	Input	FTU4	0/1	0	0	0/1	0/1	0/1	1
	I2C3SCL	I/O	FTU1	0/1	1	[PTFR1]	1	0/1	0/1	1
	TSPI2CS0	Output	FTU1	0/1	1	[PTFR2]	0/1	0/1	0/1	0
	TSPI2CSIN	Input	FTU1	0/1	0	[PTFR3]	0/1	0/1	0/1	1
EI2C3SCL	I/O	FTU12	0/1	1	[PTFR4]	1	0/1	0/1	1	
PT2	After reset			0	0	0	0	0	0	0
	Input Port	Input		0/1	0	0	0/1	0/1	0/1	1
	Output Port	Output		0/1	1	0	0/1	0/1	0/1	0
	INT25	Input	FTU4	0/1	0	0	0/1	0/1	0/1	1
	TSPI2SCK	Input	FTU1	0/1	0	[PTFR1]	0/1	0/1	0/1	1
		Output		0/1	1		0/1	0/1	0/1	0
	T32A06OUTB	Output	FTU1	0/1	1	[PTFR3]	0/1	0/1	0/1	0
PT3	After reset			0	0	0	0	0	0	0
	Input Port	Input		0/1	0	0	0/1	0/1	0/1	1
	Output Port	Output		0/1	1	0	0/1	0/1	0/1	0
	INT26	Input	FTU4	0/1	0	0	0/1	0/1	0/1	1
	TSPI2TXD	Output	FTU2	0/1	1	[PTFR1]	0/1	0/1	0/1	0
	T32A06INB0	Input	FTU1	0/1	0	[PTFR3]	0/1	0/1	0/1	1
PT4	After reset			0	0	0	0	0	0	0
	Input Port	Input		0/1	0	0	0/1	0/1	0/1	1
	Output Port	Output		0/1	1	0	0/1	0/1	0/1	0
	TSPI2RXD	Input	FTU1	0/1	0	[PTFR1]	0/1	0/1	0/1	1
	T32A06INB1	Input	FTU1	0/1	0	[PTFR3]	0/1	0/1	0/1	1
PT5	After reset			0	0	0	0	0	0	0
	Input Port	Input		0/1	0	0	0/1	0/1	0/1	1
	Output Port	Output		0/1	1	0	0/1	0/1	0/1	0
	T32A06OUTA	Output	FTU1	0/1	1	[PTFR3]	0/1	0/1	0/1	0
	T32A06OUTC	Output	FTU1	0/1	1	[PTFR4]	0/1	0/1	0/1	0
PT6	After reset			0	0	0	0	0	0	0
	Input Port	Input		0/1	0	0	0/1	0/1	0/1	1
	Output Port	Output		0/1	1	0	0/1	0/1	0/1	0
	T32A06INA0	Input	FTU1	0/1	0	[PTFR3]	0/1	0/1	0/1	1
	T32A06INC0	Input	FTU1	0/1	0	[PTFR4]	0/1	0/1	0/1	1
PT7	After reset			0	0	0	0	0	0	0
	Input Port	Input		0/1	0	0	0/1	0/1	0/1	1
	Output Port	Output		0/1	1	0	0/1	0/1	0/1	0
	INT29	Input	FTU4	0/1	0	0	0/1	0/1	0/1	1
	T32A06INA1	Input	FTU1	0/1	0	[PTFR3]	0/1	0/1	0/1	1
	T32A06INC1	Input	FTU1	0/1	0	[PTFR4]	0/1	0/1	0/1	1

4.2.18. PORT U

Table 4.22 Port U Registers Setting

PORT	Reset status	Input/output	PORT type	Control register						
	Function			[PUDATA]	[PUCR]	[PUFRn]	[PUOD]	[PUPUP]	[PUPDN]	[PUIE]
PU0	After reset			0	0	N/A	0	0	0	0
	Input Port	Input		0/1	0	N/A	0/1	0/1	0/1	1
	Output Port	Output		0/1	1	N/A	0/1	0/1	0/1	0
	INT30	Input	FTU4	0/1	0	N/A	0/1	0/1	0/1	1
PU1	After reset			0	0	N/A	0	0	0	0
	Input Port	Input		0/1	0	N/A	0/1	0/1	0/1	1
	Output Port	Output		0/1	1	N/A	0/1	0/1	0/1	0
	INT31	Input	FTU4	0/1	0	N/A	0/1	0/1	0/1	1
PU2	After reset			0	0	N/A	0	0	0	0
	Input Port	Input		0/1	0	N/A	0/1	0/1	0/1	1
	Output Port	Output		0/1	1	N/A	0/1	0/1	0/1	0
PU3	After reset			0	0	N/A	0	0	0	0
	Input Port	Input		0/1	0	N/A	0/1	0/1	0/1	1
	Output Port	Output		0/1	1	N/A	0/1	0/1	0/1	0
PU4	After reset			0	0	N/A	0	0	0	0
	Input Port	Input		0/1	0	N/A	0/1	0/1	0/1	1
	Output Port	Output		0/1	1	N/A	0/1	0/1	0/1	0
PU5	After reset			0	0	N/A	0	0	0	0
	Input Port	Input		0/1	0	N/A	0/1	0/1	0/1	1
	Output Port	Output		0/1	1	N/A	0/1	0/1	0/1	0

4.2.19. PORT V

Table 4.23 Port V Registers Setting

PORT	Reset status	Input/output	PORT type	Control register						
	Function			[PVDATA]	[PVCR]	[PVFRn]	[PVOD]	[PVPUP]	[PVPDN]	[PVIE]
PV0	After reset			0	0	0	0	0	0	0
	Input Port	Input		0/1	0	0	0/1	0/1	0/1	1
	Output Port	Output		0/1	1	0	0/1	0/1	0/1	0
	SEG03	Output	FTU1	0/1	1	[PVFR6]	0	0	0	0
PV1	After reset			0	0	0	0	0	0	0
	Input Port	Input		0/1	0	0	0/1	0/1	0/1	1
	Output Port	Output		0/1	1	0	0/1	0/1	0/1	0
	SEG02	Output	FTU1	0/1	1	[PVFR6]	0	0	0	0
PV2	After reset			0	0	0	0	0	0	0
	Input Port	Input		0/1	0	0	0/1	0/1	0/1	1
	Output Port	Output		0/1	1	0	0/1	0/1	0/1	0
	INT17	Input	FTU4	0/1	0	0	0/1	0/1	0/1	1
PV3	After reset			0	0	0	0	0	0	0
	Input Port	Input		0/1	0	0	0/1	0/1	0/1	1
	Output Port	Output		0/1	1	0	0/1	0/1	0/1	0
	INT18	Input	FTU4	0/1	0	0	0/1	0/1	0/1	1
PV4	After reset			0	0	N/A	0	0	0	0
	Input Port	Input		0/1	0	N/A	0/1	0/1	0/1	1
	Output Port	Output		0/1	1	N/A	0/1	0/1	0/1	0
	SEG01	Output	FTU1	0/1	1	[PVFR6]	0	0	0	0
PV5	After reset			0	0	0	0	0	0	0
	Input Port	Input		0/1	0	0	0/1	0/1	0/1	1
	Output Port	Output		0/1	1	0	0/1	0/1	0/1	0
	UT4TXDB	Output	FTU1	0/1	1	[PVFR1]	0/1	0/1	0/1	0
PV6	After reset			0	0	0	0	0	0	0
	Input Port	Input		0/1	0	0	0/1	0/1	0/1	1
	Output Port	Output		0/1	1	0	0/1	0/1	0/1	0
	UT4TXDA	Output	FTU1	0/1	1	[PVFR1]	0/1	0/1	0/1	0
PV7	After reset			0	0	0	0	0	0	0
	Input Port	Input		0/1	0	0	0/1	0/1	0/1	1
	Output Port	Output		0/1	1	0	0/1	0/1	0/1	0
	UT4RXD	Input	FTU1	0/1	0	[PVFR2]	0/1	0/1	0/1	1
PV7	After reset			0	0	0	0	0	0	0
	Input Port	Input		0/1	0	0	0/1	0/1	0/1	1
	Output Port	Output		0/1	1	0	0/1	0/1	0/1	0
	UT4TXDA	Output	FTU1	0/1	1	[PVFR2]	0/1	0/1	0/1	0

5. Block Diagrams of Ports

The port has nine types of circuits, FTU1 to FTU6 and FTU10 to FTU13. Each circuit diagram is shown in the following page and after. The dot line block shows an equivalent circuit which is described in "Datasheet".

The "I/O Reset" shown in the circuit diagram is described the power on reset (POR) or the reset pin (RESET_N). Although, "I/O Reset" of debug pins (TMS/SWDIO, TDI, TDO/SWV, TCK/SWCLK, TRST_N) is the power on reset (POR) only.

5.1. Type FTU1

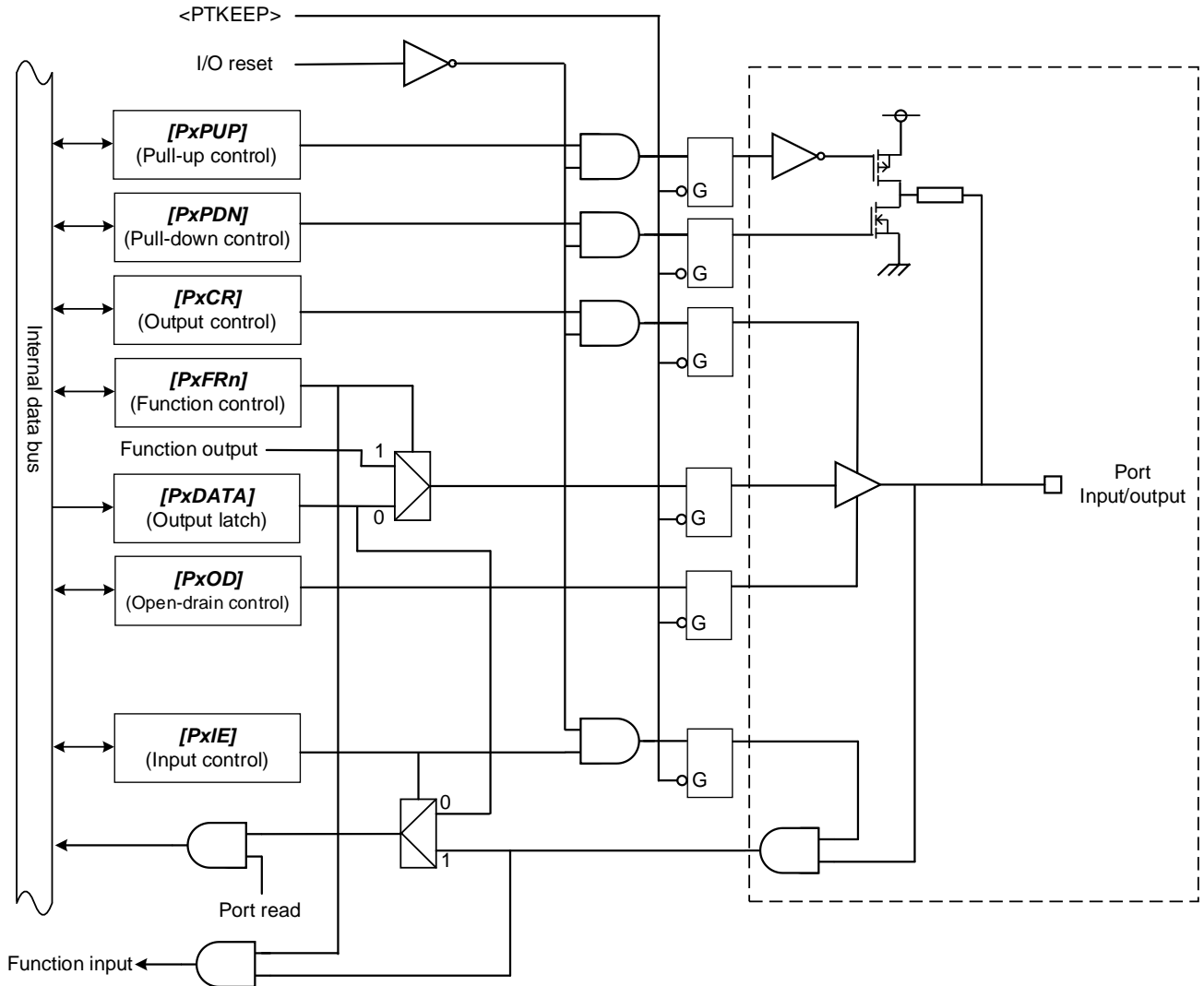

Figure 5.1 Port Type FTU1

Note: **[PxIE]** is not available on PB0 pin.

5.2. Type FTU2

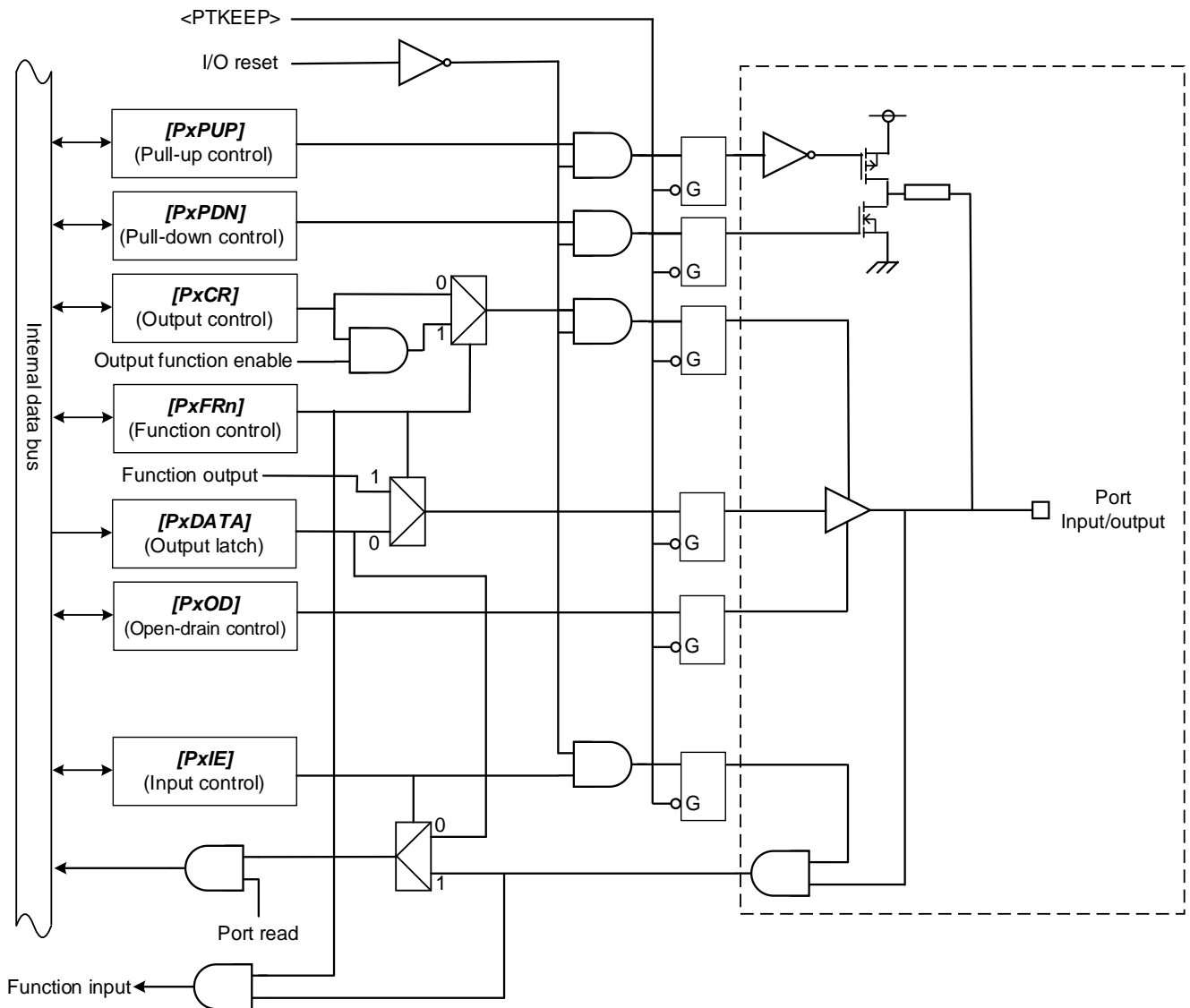

Figure 5.2 Port Type FTU2

5.4. Type FTU4

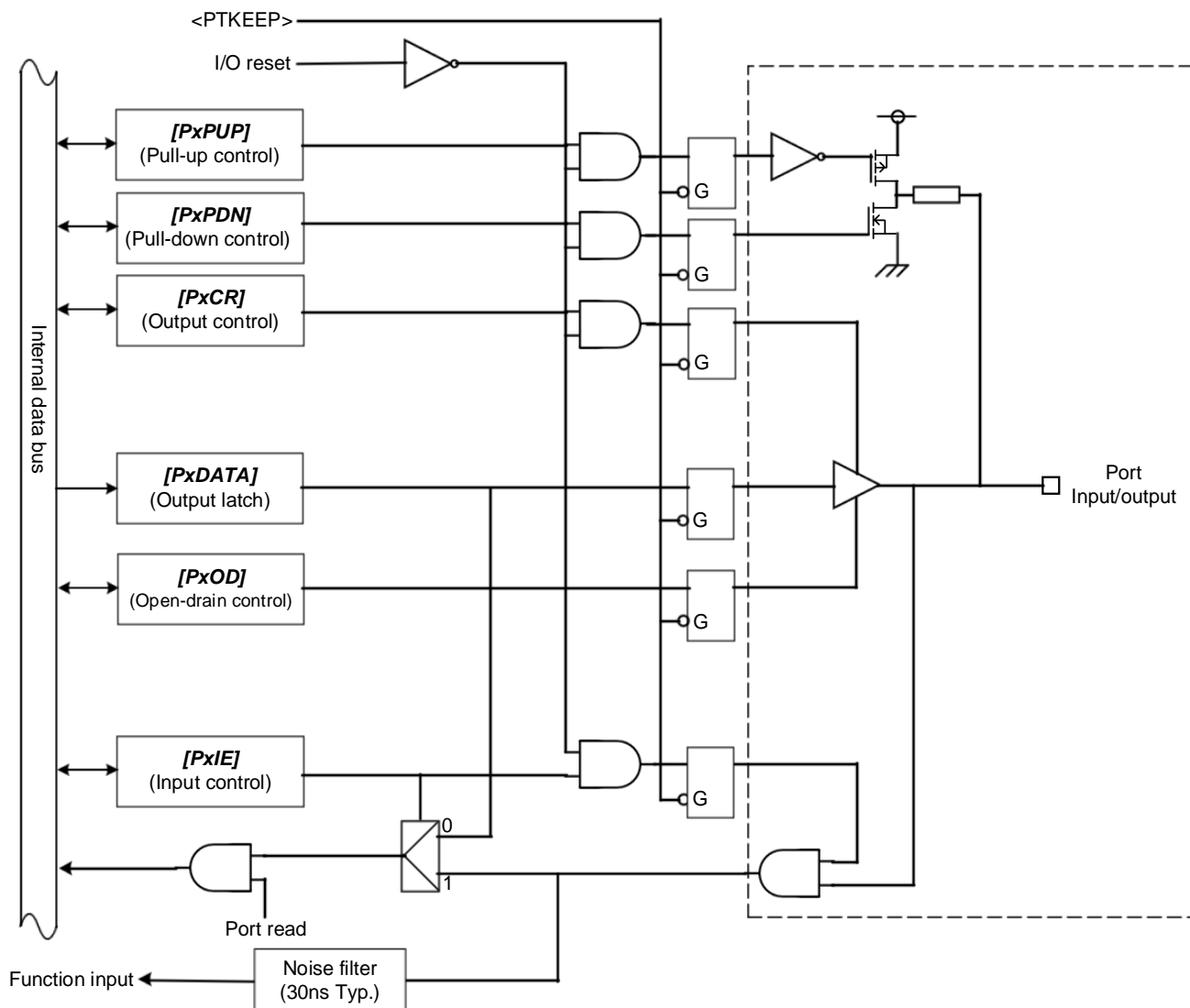

Figure 5.4 Port Type FTU4

5.5. Type FTU5

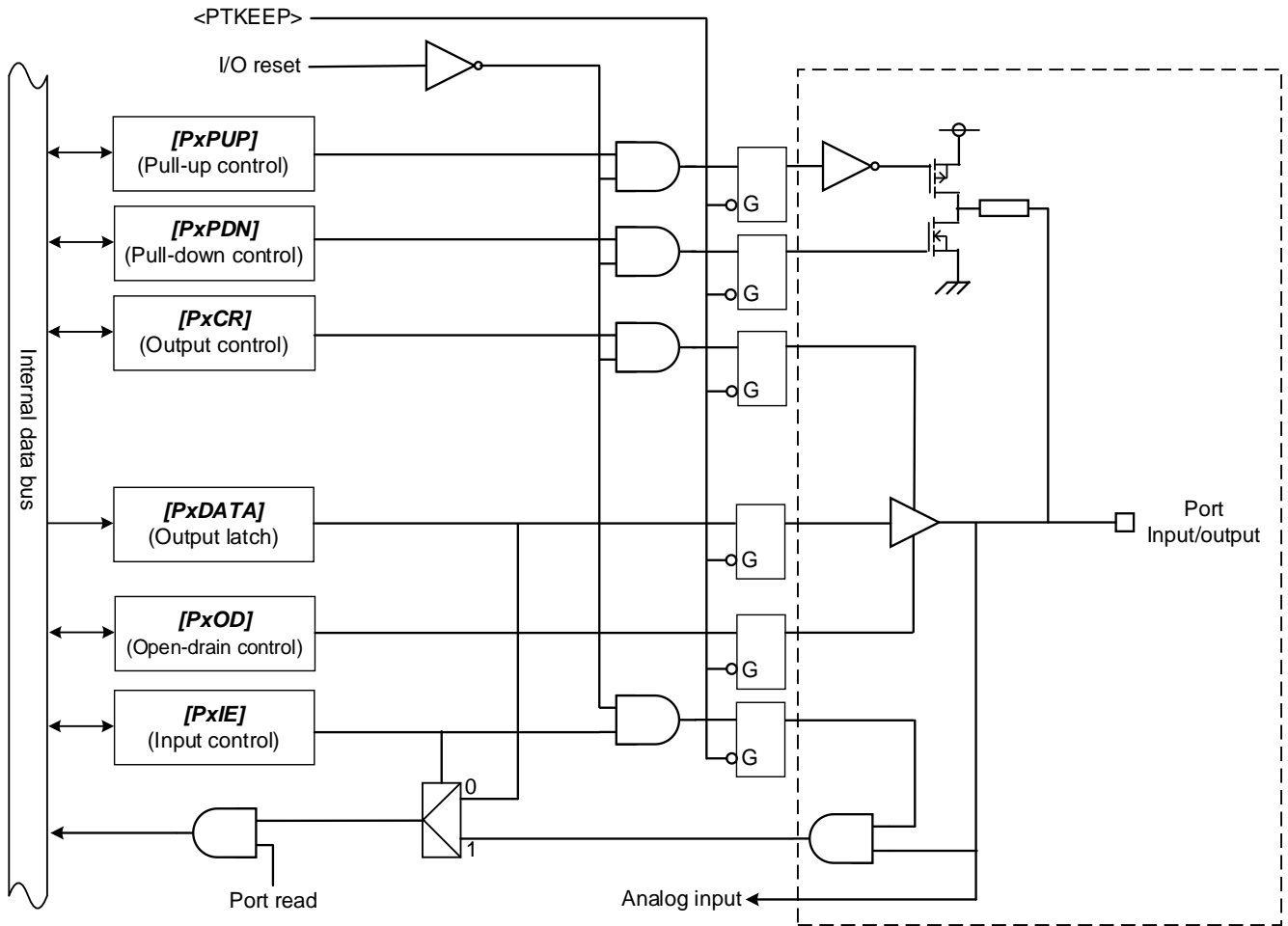

Figure 5.5 Port Type FTU5

5.6. Type FTU6

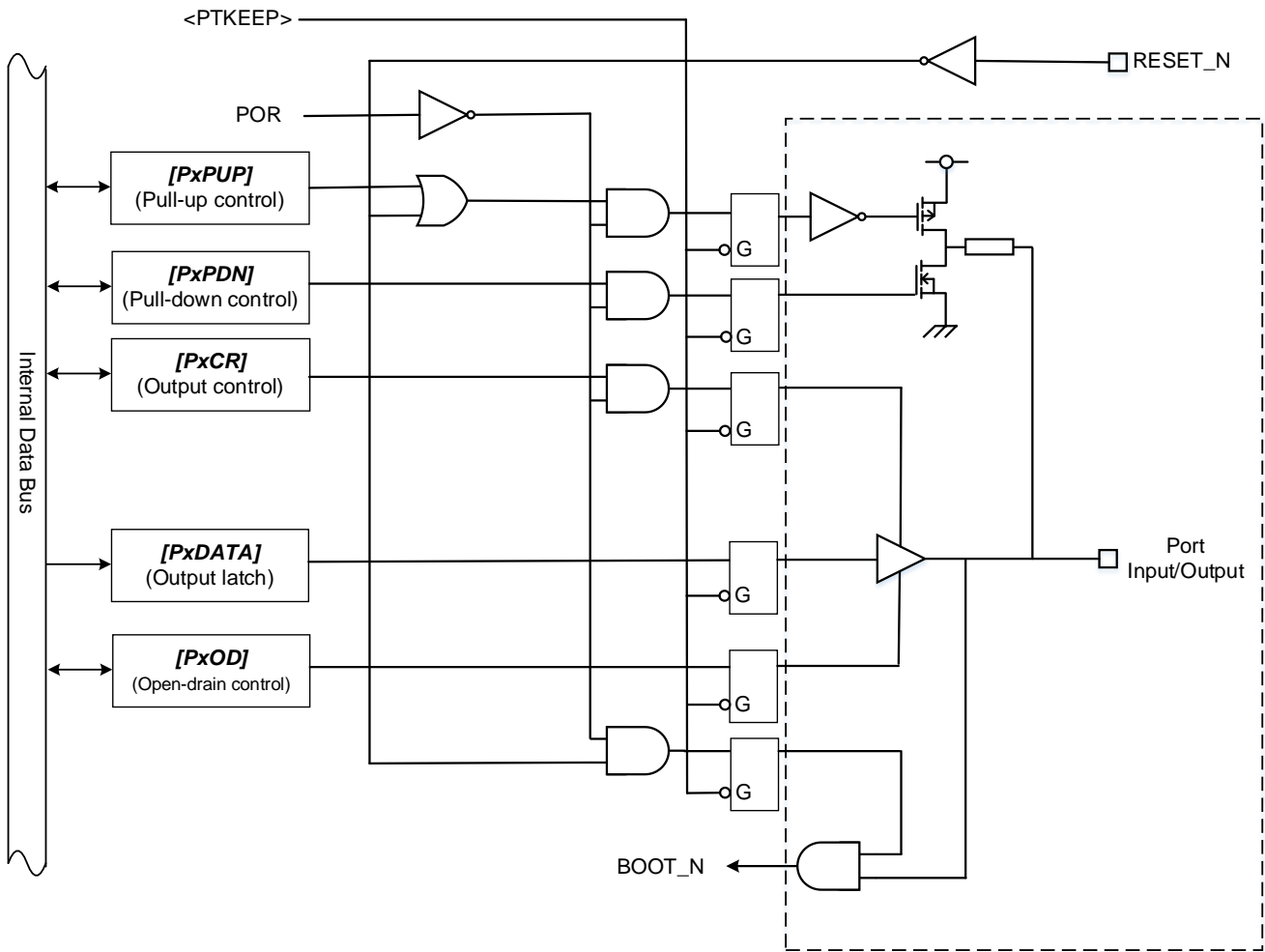

Figure 5.6 Port Type FTU6

5.7. Type FTU10

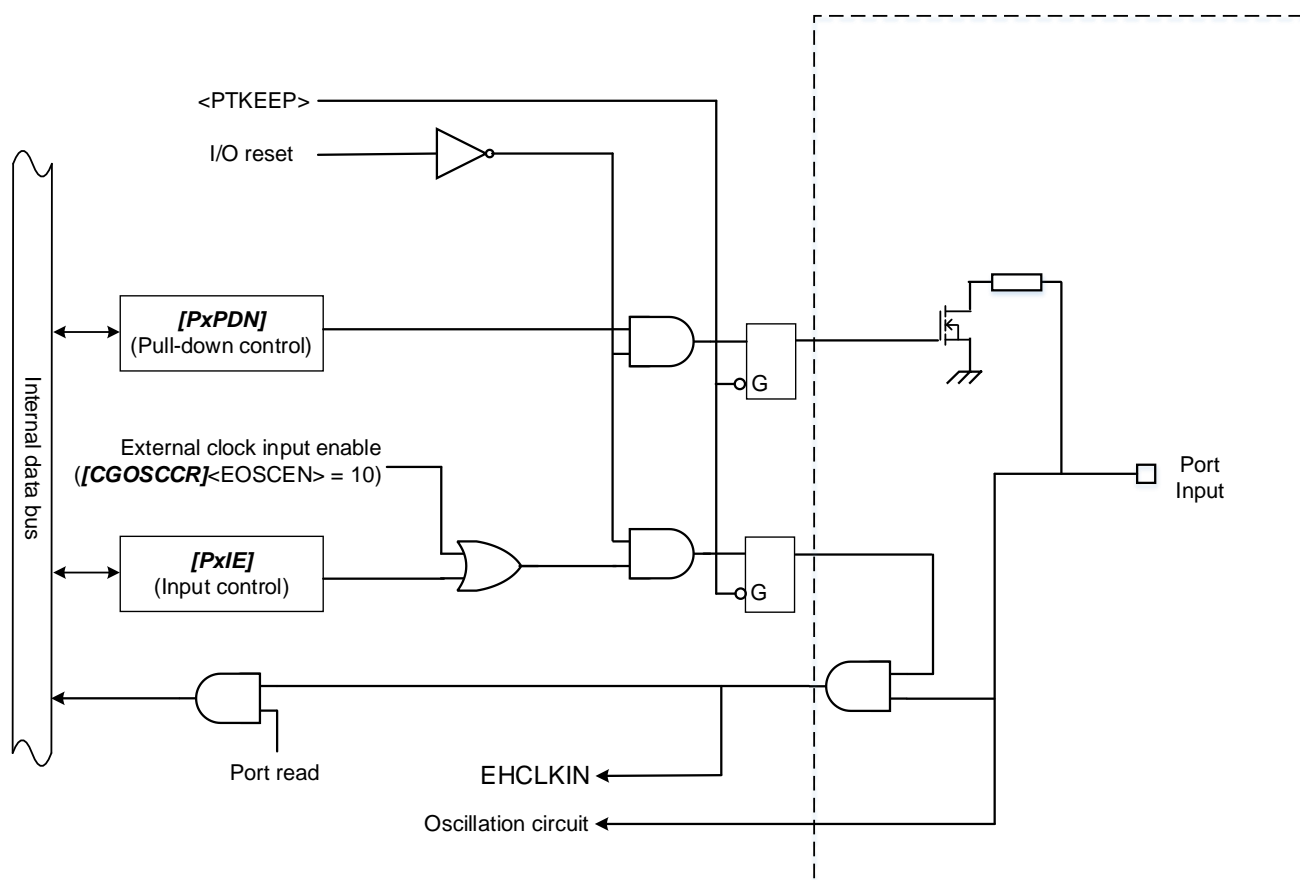

Figure 5.7 Port Type FTU10

5.8. Type FTU11

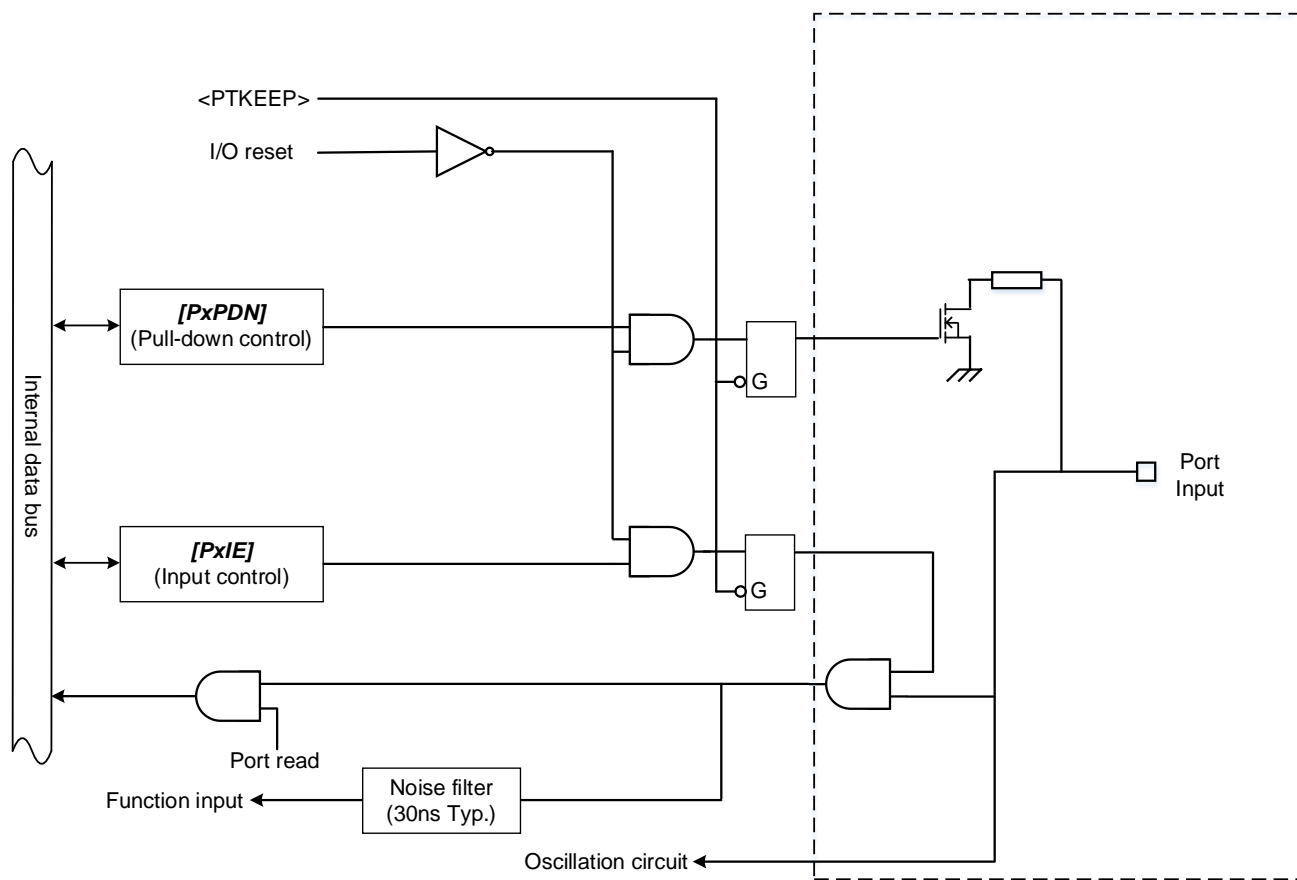

Figure 5.8 Port Type FTU11

6. Precaution

6.1. Pin Status during Reset Period

During the reset period, the pin status is high impedance except for below pins. And, the pull-up/pull-down is invalid.

- The debug interface alternate pins(PL0 to PL4) are debug pin status.
- PB0(BOOT_N) works as a BOOT function. It is enabled to be input and pulled-up during pin reset period. At the rising edge of the reset signal, if PB0 is "High", the device enters single chip mode and boots from the on chip flash memory. If PB0 is "Low", the device enters single BOOT mode and boots from the internal BOOT ROM program.

6.2. Unused Pins

We recommend that each unused pin should be connected to the power supply pins or GND pins via resistors.

Generally, if MCUs operate while the high-impedance pins left open, electrostatic damage or latch-up may occur in the internal LSI due to induced voltage influenced from external noise.

6.3. Important Points of Using Debug Interface Pins Used as General-purpose Ports

After releasing reset, If the debug interface pins are used as the general I/O ports by the user program, the debug tool cannot be connected

If the debug tool cannot be connected, it can recover debug connection to erase the flash memory using UART connection set as single BOOT mode from external. For details, please refer to reference manual "Flash memory".

7. Revision History

Table 7.1 Revision History

Revision	Date	Description
1.0	2023-04-28	First release
1.1	2025-02-21	<ul style="list-style-type: none">- Appearance update- 4.2.3. PORT B Changed table 4.7 and note- 4.2.9. PORT H Changed table 4.13- 5. Block Diagrams of Ports Changed description- 5.7. Type FTU10 Added 5.7 chapter- 5.8. Type FTU11 Changed figure 5.8Deleted note1 and note2

RESTRICTIONS ON PRODUCT USE

Toshiba Corporation and its subsidiaries and affiliates are collectively referred to as "TOSHIBA". Hardware, software and systems described in this document are collectively referred to as "Product".

- TOSHIBA reserves the right to make changes to the information in this document and related Product without notice.
- This document and any information herein may not be reproduced without prior written permission from TOSHIBA. Even with TOSHIBA's written permission, reproduction is permissible only if reproduction is without alteration/omission.
- Though TOSHIBA works continually to improve Product's quality and reliability, Product can malfunction or fail. Customers are responsible for complying with safety standards and for providing adequate designs and safeguards for their hardware, software and systems which minimize risk and avoid situations in which a malfunction or failure of Product could cause loss of human life, bodily injury or damage to property, including data loss or corruption. Before customers use the Product, create designs including the Product, or incorporate the Product into their own applications, customers must also refer to and comply with (a) the latest versions of all relevant TOSHIBA information, including without limitation, this document, the specifications, the data sheets and application notes for Product and the precautions and conditions set forth in the "TOSHIBA Semiconductor Reliability Handbook" and (b) the instructions for the application with which the Product will be used with or for. Customers are solely responsible for all aspects of their own product design or applications, including but not limited to (a) determining the appropriateness of the use of this Product in such design or applications; (b) evaluating and determining the applicability of any information contained in this document, or in charts, diagrams, programs, algorithms, sample application circuits, or any other referenced documents; and (c) validating all operating parameters for such designs and applications. **TOSHIBA ASSUMES NO LIABILITY FOR CUSTOMERS' PRODUCT DESIGN OR APPLICATIONS.**
- **PRODUCT IS NEITHER INTENDED NOR WARRANTED FOR USE IN EQUIPMENTS OR SYSTEMS THAT REQUIRE EXTRAORDINARILY HIGH LEVELS OF QUALITY AND/OR RELIABILITY, AND/OR A MALFUNCTION OR FAILURE OF WHICH MAY CAUSE LOSS OF HUMAN LIFE, BODILY INJURY, SERIOUS PROPERTY DAMAGE AND/OR SERIOUS PUBLIC IMPACT ("UNINTENDED USE").** Except for specific applications as expressly stated in this document, Unintended Use includes, without limitation, equipment used in nuclear facilities, equipment used in the aerospace industry, lifesaving and/or life supporting medical equipment, equipment used for automobiles, trains, ships and other transportation, traffic signaling equipment, equipment used to control combustions or explosions, safety devices, elevators and escalators, and devices related to power plant. **IF YOU USE PRODUCT FOR UNINTENDED USE, TOSHIBA ASSUMES NO LIABILITY FOR PRODUCT.** For details, please contact your TOSHIBA sales representative or contact us via our website.
- Do not disassemble, analyze, reverse-engineer, alter, modify, translate or copy Product, whether in whole or in part.
- Product shall not be used for or incorporated into any products or systems whose manufacture, use, or sale is prohibited under any applicable laws or regulations.
- The information contained herein is presented only as guidance for Product use. No responsibility is assumed by TOSHIBA for any infringement of patents or any other intellectual property rights of third parties that may result from the use of Product. No license to any intellectual property right is granted by this document, whether express or implied, by estoppel or otherwise.
- **ABSENT A WRITTEN SIGNED AGREEMENT, EXCEPT AS PROVIDED IN THE RELEVANT TERMS AND CONDITIONS OF SALE FOR PRODUCT, AND TO THE MAXIMUM EXTENT ALLOWABLE BY LAW, TOSHIBA (1) ASSUMES NO LIABILITY WHATSOEVER, INCLUDING WITHOUT LIMITATION, INDIRECT, CONSEQUENTIAL, SPECIAL, OR INCIDENTAL DAMAGES OR LOSS, INCLUDING WITHOUT LIMITATION, LOSS OF PROFITS, LOSS OF OPPORTUNITIES, BUSINESS INTERRUPTION AND LOSS OF DATA, AND (2) DISCLAIMS ANY AND ALL EXPRESS OR IMPLIED WARRANTIES AND CONDITIONS RELATED TO SALE, USE OF PRODUCT, OR INFORMATION, INCLUDING WARRANTIES OR CONDITIONS OF MERCHANTABILITY, FITNESS FOR A PARTICULAR PURPOSE, ACCURACY OF INFORMATION, OR NONINFRINGEMENT.**
- Do not use or otherwise make available Product or related software or technology for any military purposes, including without limitation, for the design, development, use, stockpiling or manufacturing of nuclear, chemical, or biological weapons or missile technology products (mass destruction weapons). Product and related software and technology may be controlled under the applicable export laws and regulations including, without limitation, the Japanese Foreign Exchange and Foreign Trade Law and the U.S. Export Administration Regulations. Export and re-export of Product or related software or technology are strictly prohibited except in compliance with all applicable export laws and regulations.
- Please contact your TOSHIBA sales representative for details as to environmental matters such as the RoHS compatibility of Product. Please use Product in compliance with all applicable laws and regulations that regulate the inclusion or use of controlled substances, including without limitation, the EU RoHS Directive. **TOSHIBA ASSUMES NO LIABILITY FOR DAMAGES OR LOSSES OCCURRING AS A RESULT OF NONCOMPLIANCE WITH APPLICABLE LAWS AND REGULATIONS.**