

Thermoflagger™ – realizing a simple overheating monitor solution

Thermoflagger™ can be used in conjunction with PTC thermistors (*) to build an overheating monitor solution that detects abnormal heat generation. A simple and space-saving protection circuit can be constructed to deal with abnormal heating of electronic equipment.

Introduction to Thermoflagger™

As electronic devices become more sophisticated and dense, the heat generated by semiconductor elements and electronic components is increasing. This challenge underscores the importance of monitoring over temperature to ensure systems are not negatively impacted by severe heat issues. Thermoflagger™ can be used in conjunction with PTC thermistors to detect abnormal heat generation in a simple configuration.

Thermoflagger™ Application circuit example

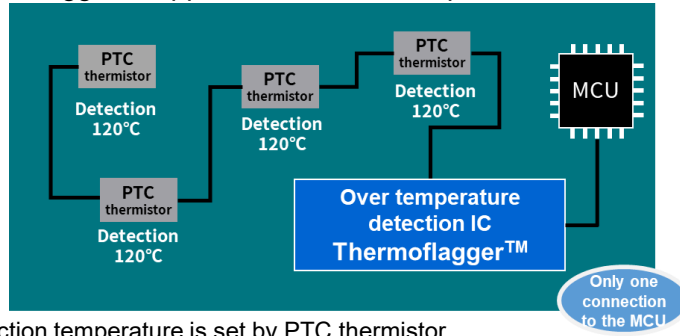

Detection temperature is set by PTC thermistor

Thermoflagger™ has a comparator and a constant current source inside the IC and compares the voltage drop with the internal reference voltage by applying a constant current to PTC thermistor. When the temperature around the PTC thermistor rises, the terminal voltage rises due to the exponential resistance increase of the PTC thermistor. Therefore, abnormal heat generation can be easily detected by comparing the voltage with the built-in comparator.

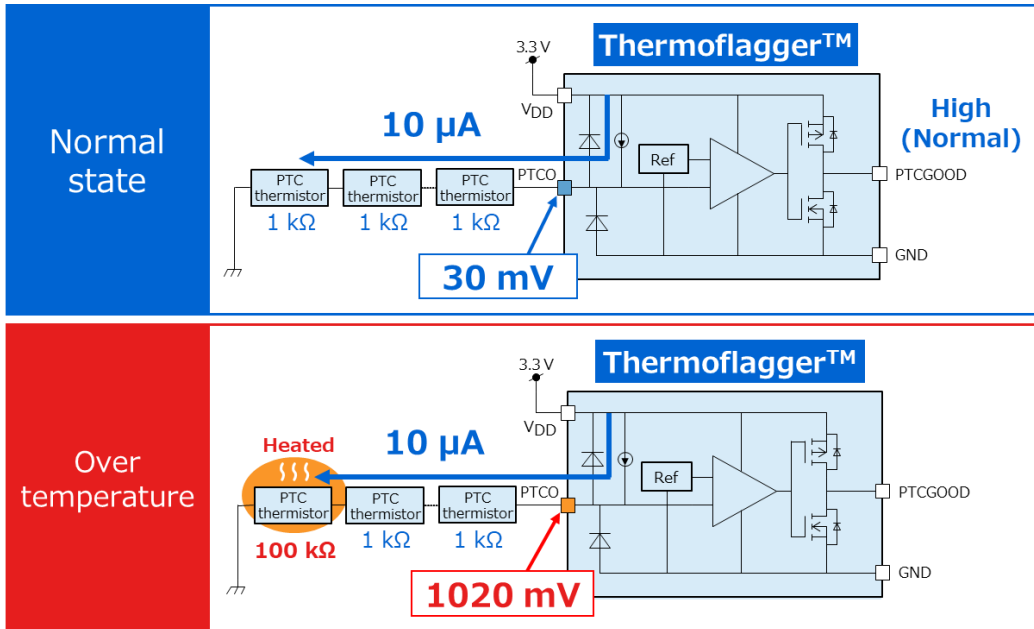

In case of 3 PTC thermistors.

[Click here for Thermoflagger™ product page](#)

Click

※A thermistor is an element whose electrical resistance value changes as the temperature changes. PTC thermistor is a thermistor whose electric resistivity increases as the temperature rises.

Advantages of Thermoflagger™

The overheat monitoring solution with Thermoflagger™(TCTH series) and PTC thermistors has the following advantages:

Advantage 1: Simplified circuit design for overheat monitoring

Compared with the discrete configuration example as shown in the table below, the number of parts is reduced and the circuit design is simplified.

It is also possible to reduce the component mounting area.

Composition	Discrete Configuration 1 Individual IC basis		Discrete Configuration 2 Transistor base		Thermoflagger™ Monolithic IC based	
Circuit example						
Number of components (excluding PTC)	○	3pcs	×	5pcs	◎	1pc
Mounting area	○	Area for IC2 piece	×	Due to the large number of parts	◎	Area for IC1 of small packages
Precision	○	Susceptible to changes in power supply voltage	×	Variations in power supply voltage and transistor variations and temperature characteristics	◎	Constant current configuration with no effect on power supply voltage change
Price	△	IC 2 circuitry + resistor	◎	Tr × 2pcs + number of resistors	○	IC 1 circuitry
Design for each set	×	Constant change due to power supply voltage change (IC change)	×	Constant change due to power supply voltage change and Tr property	◎	According to the temperature setting No adjustment required for operation

◎:Excellent, ○:Good, △:Average, x:Poor

Advantage 2: Wide range of overheat monitoring possible at low cost

Compared to configurations with multiple sensor ICs (e.g. temperature sensors), one Thermoflagger™ (Overheat Monitoring IC) and a relatively inexpensive PTC thermistor configuration, enable low-cost, extensive overheat monitoring.

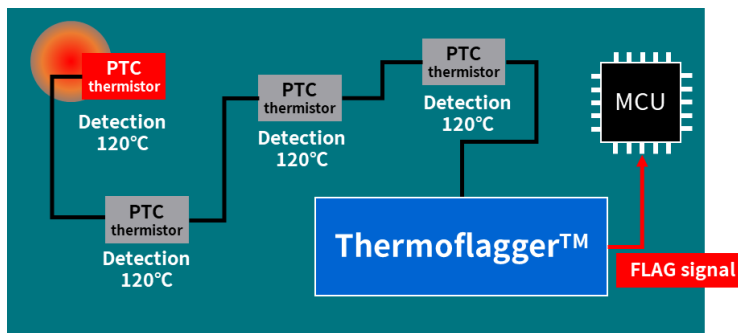

Abnormal heat generation is monitored by combining Thermoflagger™ and PTC thermistor located at the heat generating position.

Advantage 3: Create a fail-safe circuit combined with other protection ICs

In addition to monitoring with a sensor IC (e.g. temperature sensor), combining an additional layer of monitoring with Thermoflagger™ and PTC thermistors creates a robust and fail-safe overhear monitor solution to protect the circuitry.

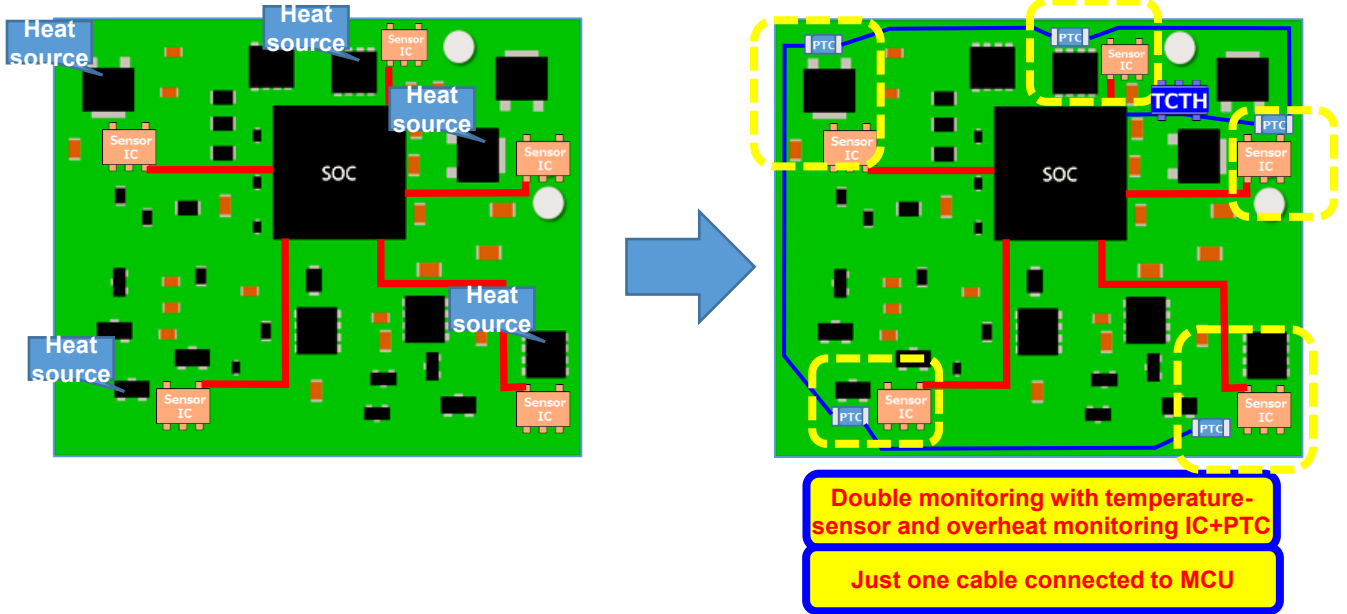

Thermoflagger™ lineup

Product name	PTCO Output current (typ.)	PTC Thermistor Selection range	Abnormal time Latch function	PTCGOOD Output type	Package
TCTH011AE	1μA	4.7 kΩ to 10 kΩ	-	Push-pull	<div style="border: 1px solid black; padding: 5px;"> <p style="text-align: center; margin: 0;">ESV (SOT-553)</p>  <p style="text-align: center; margin: 0;">1.6 x 1.6</p> </div>
TCTH012AE	1μA	4.7 kΩ to 10 kΩ	✓ Yes	Push-pull	
TCTH021AE	10μA	470 Ω to 1 kΩ	-	Push-pull	
TCTH022AE	10μA	470 Ω to 1 kΩ	✓ Yes	Push-pull	
TCTH011BE	1μA	4.7 kΩ to 10 kΩ	-	Open-drain	
TCTH012BE	1μA	4.7 kΩ to 10 kΩ	✓ Yes	Open-drain	
TCTH021BE	10μA	470 Ω to 1 kΩ	-	Open-drain	
TCTH022BE	10μA	470 Ω to 1 kΩ	✓ Yes	Open-drain	

Related LINK

- [Click here for an introduction to Thermoflagger™](#)
- [Online distributor purchase, inventory search page](#)
- [Click here for the parametric search for the product.](#)
- [Click here for special features on Thermoflagger™](#)
- [Click here for the reference design](#)

- [Click](#)
- [Click](#)
- [Click](#)
- [Click](#)
- [Click](#)

Thermoflagger™ is a trademark of Toshiba Electronic Devices & Storage Corporation.

The company name, trademark name, service name, etc. may be used as trademarks by each company.

RESTRICTIONS ON PRODUCT USE

Toshiba Corporation and its subsidiaries and affiliates are collectively referred to as "TOSHIBA".

Hardware, software and systems described in this document are collectively referred to as "Product".

- TOSHIBA reserves the right to make changes to the information in this document and related Product without notice.
- This document and any information herein may not be reproduced without prior written permission from TOSHIBA. Even with TOSHIBA's written permission, reproduction is permissible only if reproduction is without alteration/omission.
- Though TOSHIBA works continually to improve Product's quality and reliability, Product can malfunction or fail. Customers are responsible for complying with safety standards and for providing adequate designs and safeguards for their hardware, software and systems which minimize risk and avoid situations in which a malfunction or failure of Product could cause loss of human life, bodily injury or damage to property, including data loss or corruption. Before customers use the Product, create designs including the Product, or incorporate the Product into their own applications, customers must also refer to and comply with (a) the latest versions of all relevant TOSHIBA information, including without limitation, this document, the specifications, the data sheets and application notes for Product and the precautions and conditions set forth in the "TOSHIBA Semiconductor Reliability Handbook" and (b) the instructions for the application with which the Product will be used with or for. Customers are solely responsible for all aspects of their own product design or applications, including but not limited to (a) determining the appropriateness of the use of this Product in such design or applications; (b) evaluating and determining the applicability of any information contained in this document, or in charts, diagrams, programs, algorithms, sample application circuits, or any other referenced documents; and (c) validating all operating parameters for such designs and applications. TOSHIBA ASSUMES NO LIABILITY FOR CUSTOMERS' PRODUCT DESIGN OR APPLICATIONS.
- PRODUCT IS NEITHER INTENDED NOR WARRANTED FOR USE IN EQUIPMENTS OR SYSTEMS THAT REQUIRE EXTRAORDINARILY HIGH LEVELS OF QUALITY AND/OR RELIABILITY, AND/OR A MALFUNCTION OR FAILURE OF WHICH MAY CAUSE LOSS OF HUMAN LIFE, BODILY INJURY, SERIOUS PROPERTY DAMAGE AND/OR SERIOUS PUBLIC IMPACT ("UNINTENDED USE"). Except for specific applications as expressly stated in this document, Unintended Use includes, without limitation, equipment used in nuclear facilities, equipment used in the aerospace industry, Class 3 medical devices, equipment used for automobiles, and military vehicles and munitions. IF YOU USE PRODUCT FOR UNINTENDED USE, TOSHIBA ASSUMES NO LIABILITY FOR PRODUCT. For details, please contact your TOSHIBA sales representative or contact us via our website.
- Do not disassemble, analyze, reverse-engineer, alter, modify, translate or copy Product, whether in whole or in part.
- Product shall not be used for or incorporated into any products or systems whose manufacture, use, or sale is prohibited under any applicable laws or regulations.
- The information contained herein is presented only as guidance for Product use. No responsibility is assumed by TOSHIBA for any infringement of patents or any other intellectual property rights of third parties that may result from the use of Product. No license to any intellectual property right is granted by this document, whether express or implied, by estoppel or otherwise.
- ABSENT A WRITTEN SIGNED AGREEMENT, EXCEPT AS PROVIDED IN THE RELEVANT TERMS AND CONDITIONS OF SALE FOR PRODUCT, AND TO THE MAXIMUM EXTENT ALLOWABLE BY LAW, TOSHIBA (1) ASSUMES NO LIABILITY WHATSOEVER, INCLUDING WITHOUT LIMITATION, INDIRECT, CONSEQUENTIAL, SPECIAL, OR INCIDENTAL DAMAGES OR LOSS, INCLUDING WITHOUT LIMITATION, LOSS OF PROFITS, LOSS OF OPPORTUNITIES, BUSINESS INTERRUPTION AND LOSS OF DATA, AND (2) DISCLAIMS ANY AND ALL EXPRESS OR IMPLIED WARRANTIES AND CONDITIONS RELATED TO SALE, USE OF PRODUCT, OR INFORMATION, INCLUDING WARRANTIES OR CONDITIONS OF MERCHANTABILITY, FITNESS FOR A PARTICULAR PURPOSE, ACCURACY OF INFORMATION, OR NONINFRINGEMENT.
- Do not use or otherwise make available Product or related software or technology for any military purposes, including without limitation, for the design, development, use, stockpiling or manufacturing of nuclear, chemical, or biological weapons or missile technology products (mass destruction weapons). Product and related software and technology may be controlled under the applicable export laws and regulations including, without limitation, the Japanese Foreign Exchange and Foreign Trade Law and the U.S. Export Administration Regulations. Export and re-export of Product or related software or technology are strictly prohibited except in compliance with all applicable export laws and regulations.
- Please contact your TOSHIBA sales representative for details as to environmental matters such as the RoHS compatibility of Product. Please use Product in compliance with all applicable laws and regulations that regulate the inclusion or use of controlled substances, including without limitation, the EU RoHS Directive. TOSHIBA ASSUMES NO LIABILITY FOR DAMAGES OR LOSSES OCCURRING AS A RESULT OF NONCOMPLIANCE WITH APPLICABLE LAWS AND REGULATIONS.

Company names, product names, and service names may be trademarks of respective companies.

Toshiba Electronic Devices & Storage Corporation

<https://toshiba.semicon-storage.com/>