

Zener Diode Silicon Epitaxial Planar

MSZ series

1. Applications

- (1) Voltage surge protection

2. Features

- (1) Small package
- (2) The typical voltage of VZ is accorded to E24 series.

3. Packaging and Internal Circuit

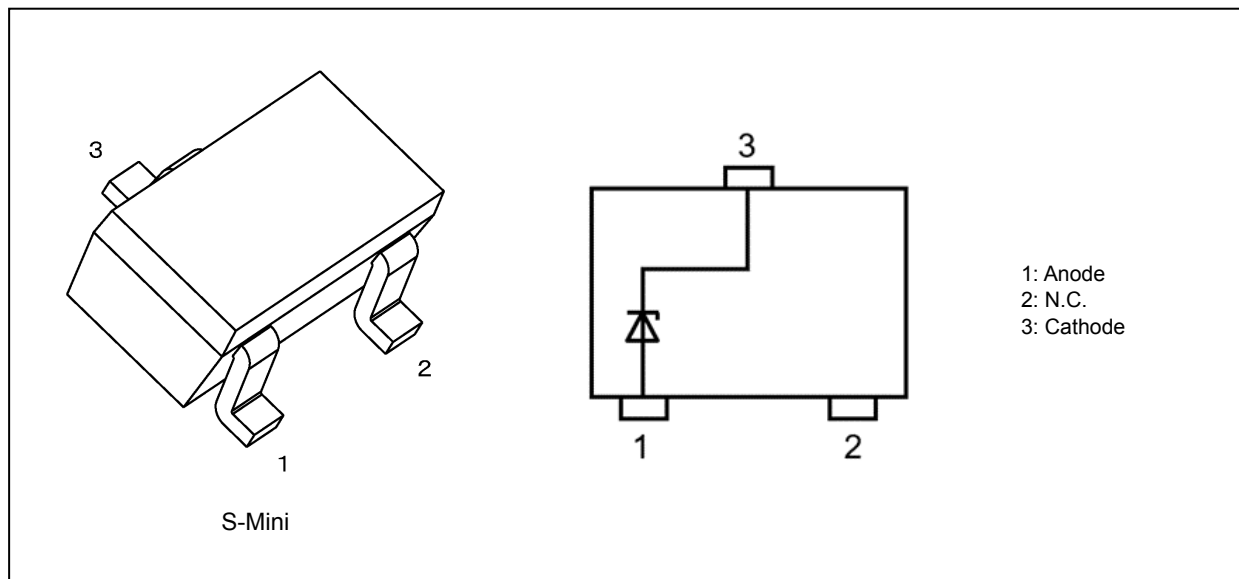

4. Absolute Maximum Ratings 1 (Note) (Unless otherwise specified, $T_a = 25\text{ }^\circ\text{C}$)

Characteristics	Symbol	Note	Rating	Unit
Power dissipation	P_D		200	mW
		(Note 1)	600	
Junction temperature	T_j		150	$^\circ\text{C}$
Storage temperature	T_{stg}		-55 to 150	

Note: Using continuously under heavy loads (e.g. the application of high temperature/current/voltage and the significant change in temperature, etc.) may cause this product to decrease in the reliability significantly even if the operating conditions (i.e. operating temperature/current/voltage, etc.) are within the absolute maximum ratings.

Please design the appropriate reliability upon reviewing the Toshiba Semiconductor Reliability Handbook ("Handling Precautions"/"Derating Concept and Methods") and individual reliability data (i.e. reliability test report and estimated failure rate, etc).

Note 1: Mounted on a glass epoxy circuit board of 25.4 mm × 25.4 mm × 1.6 mm, Cu pad: 645 mm²

Start of commercial production
2020-07

5. Absolute Maximum Ratings 2 (Note) (Unless otherwise specified, T_a = 25 °C)

Type No.	Electrostatic discharge voltage (Contact, Air) V _{ESD} (kV) (Note 1)	Peak pulse power P _{PK} (W) (Note 2)	Peak pulse current I _{PP} (A) (Note 2)
MSZ5V6	±30	155	12.0
MSZ6V2	±30	175	11.0
MSZ6V8	±30	180	10.0
MSZ7V5	±30	190	9.5
MSZ8V2	±30	200	8.5
MSZ9V1	±30	200	8.0
MSZ10V	±30	200	7.5
MSZ11V	±30	200	7.25
MSZ12V	±30	200	7.0
MSZ13V	±30	200	6.5
MSZ15V	±30	200	5.6
MSZ16V	±30	200	5.5
MSZ18V	±30	200	5.1
MSZ20V	±30	200	5.0
MSZ22V	±30	200	4.75
MSZ24V	±30	200	4.5
MSZ27V	±20	200	4.1
MSZ30V	±20	200	4.0
MSZ33V	±17	200	3.5
MSZ36V	±12	200	3.0

Note: Using continuously under heavy loads (e.g. the application of high temperature/current/voltage and the significant change in temperature, etc.) may cause this product to decrease in the reliability significantly even if the operating conditions (i.e. operating temperature/current/voltage, etc.) are within the absolute maximum ratings.

Please design the appropriate reliability upon reviewing the Toshiba Semiconductor Reliability Handbook ("Handling Precautions"/"Derating Concept and Methods") and individual reliability data (i.e. reliability test report and estimated failure rate, etc).

Note1: According to IEC61000-4-2.

Note2: according to IEC61000-4-5 (t_p = 8 / 20 μs)

6. Electrical Characteristics (Unless otherwise specified, $T_a = 25\text{ }^\circ\text{C}$)

Type No.	Zener Voltage V_Z (V)				Dynamic Impedance Z_Z (Ω)		Dynamic Resistance R_{DYN} (Ω) (Note 1)	Clamp Voltage V_C (V) (Note 1) (Note 2)	Total Capacitance C_t (pF) (Note 3)	Reverse Current I_R (μA)	
	Min	Typ.	Max	Test Current I_Z (mA)	Max	Test Current I_Z (mA)	Typ.	Typ.	Typ.	Max	Test Voltage V_R (V)
MSZ5V6	5.3	5.6	6.0	5	30	5	0.16	9.0	125	1	3.5
MSZ6V2	5.8	6.2	6.6	5	30	5	0.21	10.0	105	2.5	5.0
MSZ6V8	6.4	6.8	7.2	5	30	5	0.27	13.0	88	1.5	5.5
MSZ7V5	7.0	7.5	7.9	5	30	5	0.32	14.0	78	0.1	6.0
MSZ8V2	7.7	8.2	8.7	5	30	5	0.37	16.5	67	0.1	7.0
MSZ9V1	8.5	9.1	9.6	5	30	5	0.44	17.0	62	0.1	7.5
MSZ10V	9.4	10.0	10.6	5	30	5	0.52	19.0	60	0.1	8.0
MSZ11V	10.4	11.0	11.6	5	30	5	0.60	24.0	48	0.1	9.0
MSZ12V	11.4	12.0	12.6	5	30	5	0.70	26.0	44	0.1	10.0
MSZ13V	12.4	13.0	14.1	5	30	5	0.80	27.0	42	0.1	11.0
MSZ15V	13.8	15.0	15.6	5	30	5	0.60	24.0	36	0.1	12.0
MSZ16V	15.3	16.0	17.1	5	35	5	0.50	27.0	35	0.1	14.0
MSZ18V	16.8	18.0	19.1	5	45	5	0.40	28.5	31	0.1	16.0
MSZ20V	18.8	20.0	21.2	5	70	5	0.35	30.5	29	0.1	17.6
MSZ22V	20.8	22.0	23.3	5	70	5	0.40	32.0	27	0.1	18.0
MSZ24V	22.8	24.0	25.6	5	70	5	0.60	36.5	26	0.1	19.0
MSZ27V	25.1	27.0	28.9	2	70	2	0.90	45.0	23	0.1	23.0
MSZ30V	28.0	30.0	32.0	2	100	2	1.25	47.5	21	0.1	27.0
MSZ33V	31.0	33.0	35.0	2	100	2	1.80	57.0	19	0.1	30.0
MSZ36V	34.0	36.0	38.0	2	100	2	2.60	63.0	18	0.1	32.5

Note1: TLP parameters: $Z_0 = 50\ \Omega$, $t_p = 100\ \text{ns}$, $t_r = 300\ \text{ps}$, averaging window: $t_1 = 30\ \text{ns}$ to $t_2 = 60\ \text{ns}$, extraction of dynamic resistance using least squares fit of TLP characteristics between $I_{TLP1} = 16\ \text{A}$ and $I_{TLP2} = 30\ \text{A}$.

Note2: $I_{TLP} = 16\ \text{A}$

Note3: $V_R = 0\ \text{V}$, $f = 1\ \text{MHz}$

7. Marking List

Type No.	Marking	Type No.	Marking	Type No.	Marking
MSZ5V6	ZLL	MSZ11V	ZM3	MSZ22V	ZMA
MSZ6V2	ZLM	MSZ12V	ZM4	MSZ24V	ZMB
MSZ6V8	ZLN	MSZ13V	ZM5	MSZ27V	ZMC
MSZ7V5	ZLP	MSZ15V	ZM6	MSZ30V	ZMD
MSZ8V2	ZLQ	MSZ16V	ZM7	MSZ33V	ZME
MSZ9V1	ZLR	MSZ18V	ZM8	MSZ36V	ZMF
MSZ10V	ZM2	MSZ20V	ZM9	—	—

8. Marking

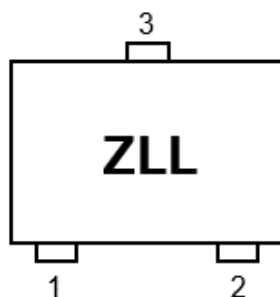

Fig. 8.1 MSZ5V6

9. Land Pattern Dimensions (for reference only)

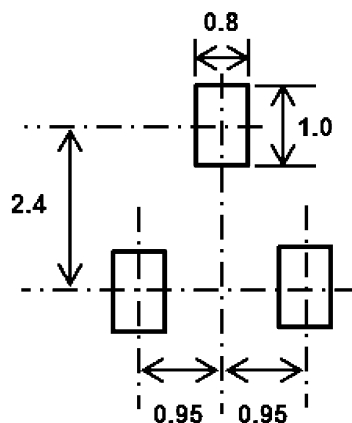

Fig. 9.1 Land Pattern Dimensions
(for reference only) (Unit: mm)

10. Characteristics Curves

10.1. MSZ series Characteristics Curves(Note)

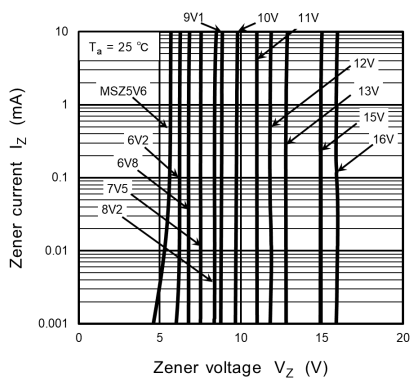

Fig. 10.1.1 $I_Z - V_Z(1)$

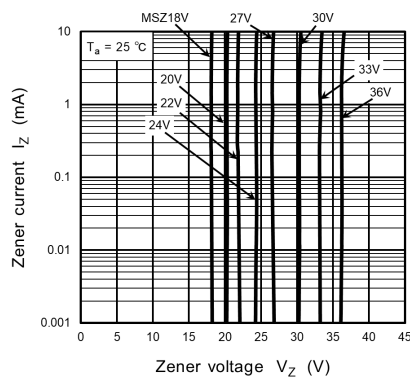

Fig. 10.1.2 $I_Z - V_Z(2)$

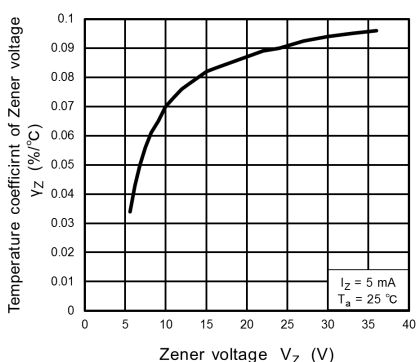

Fig. 10.1.3 $\gamma_Z - V_Z$

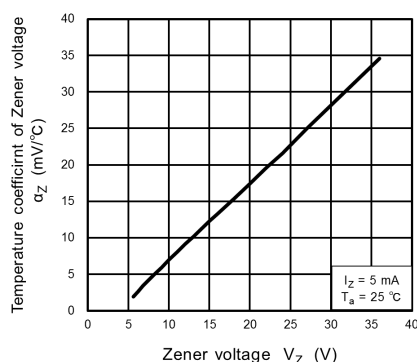

Fig. 10.1.4 $\alpha_Z - V_Z$

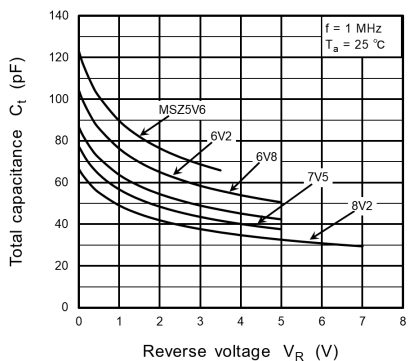

Fig. 10.1.5 $C_t - V_R (1)$

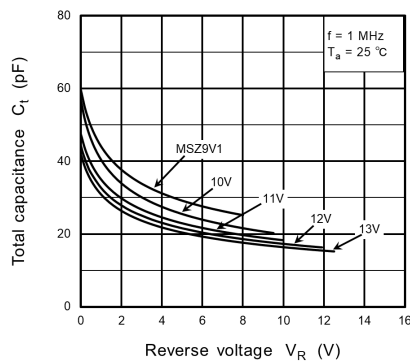

Fig. 10.1.6 $C_t - V_R (2)$

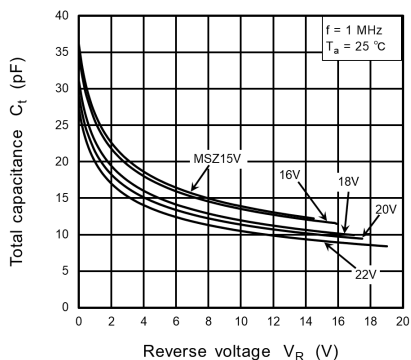

Fig. 10.1.7 $C_t - V_R (3)$

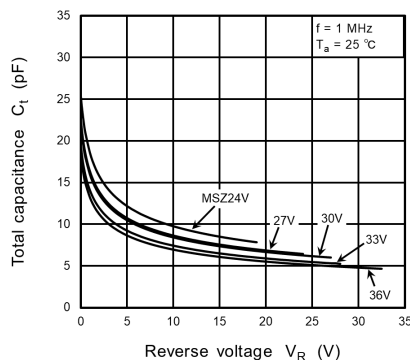

Fig. 10.1.8 $C_t - V_R (4)$

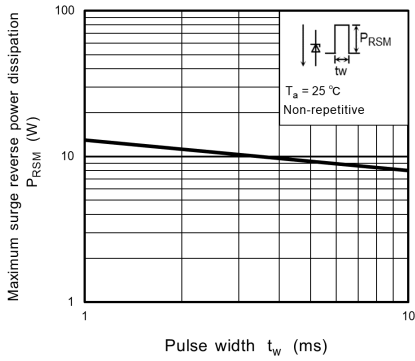

Fig. 10.1.9 $P_{RSM} - t_w$

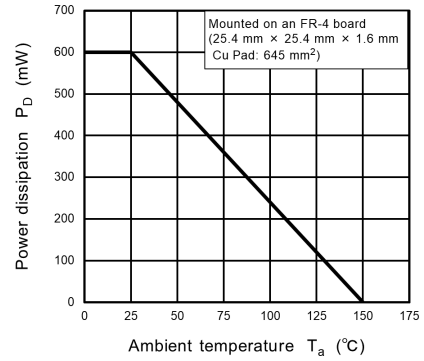

Fig. 10.1.10 $P_D - T_a$

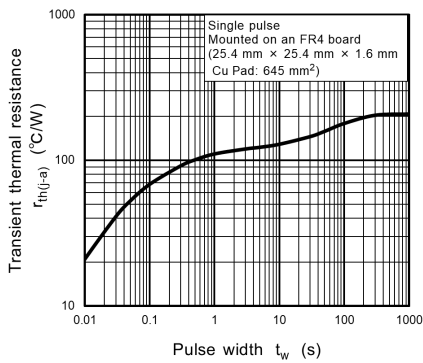

Fig. 10.1.11 $r_{th(j-a)} - t_w$

Note: The above characteristics curves are presented for reference only and not guaranteed by production test, unless otherwise noted.

10.2. MSZ5V6 Characteristics Curves(Note)

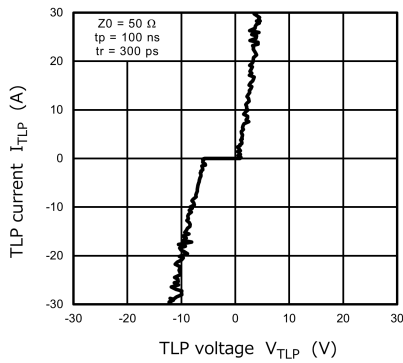

Fig. 10.2.1 $I_{TLP} - V_{TLP}$

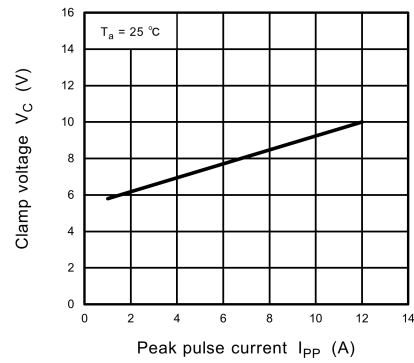

Fig. 10.2.2 $V_C - I_{PP}$

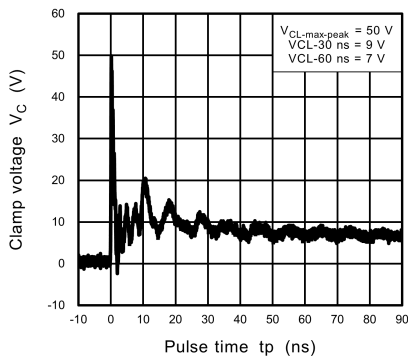

Fig. 10.2.3 IEC61000-4-2 Clamp Waveform +8 kV

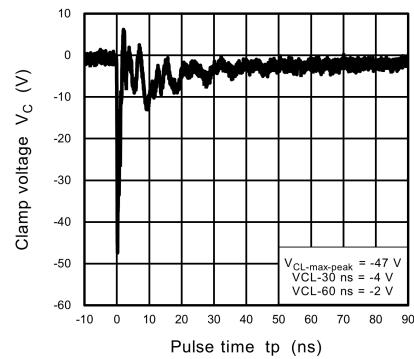

Fig. 10.2.4 IEC61000-4-2 Clamp Waveform -8 kV

Note: The above characteristics curves are presented for reference only and not guaranteed by production test, unless otherwise noted.

Refer to Fig.10.22.1, Fig.10.22.2 for peak pulse current(V_C-I_{PP}) and clamp waveform measurement circuit.

10.3. MSZ6V2 Characteristics Curves(Note)

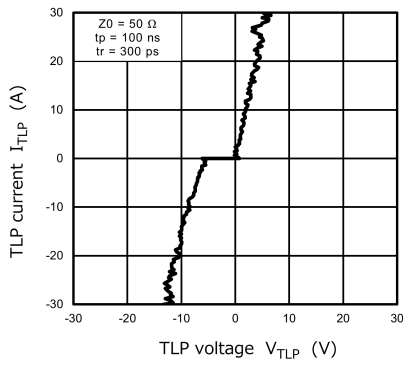

Fig. 10.3.1 $I_{TLP} - V_{TLP}$

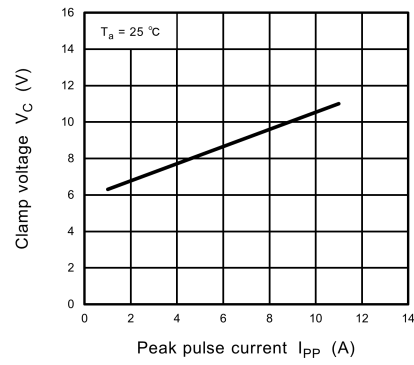
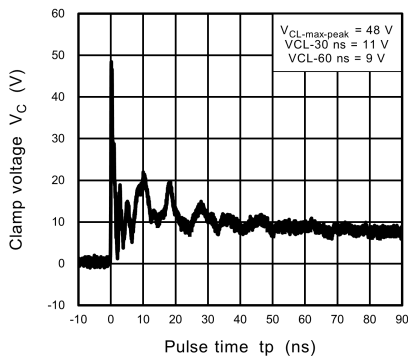
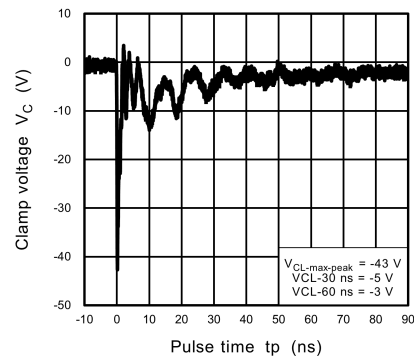

Fig. 10.3.2 $V_C - I_{PP}$



**Fig. 10.3.3 IEC61000-4-2
Clamp Waveform +8 kV**



**Fig. 10.3.4 IEC61000-4-2
Clamp Waveform -8 kV**

Note: The above characteristics curves are presented for reference only and not guaranteed by production test, unless otherwise noted.

Refer to Fig.10.22.1, Fig.10.22.2 for peak pulse current(V_C-I_{PP}) and clamp waveform measurement circuit.

10.4. MSZ6V8 Characteristics Curves(Note)

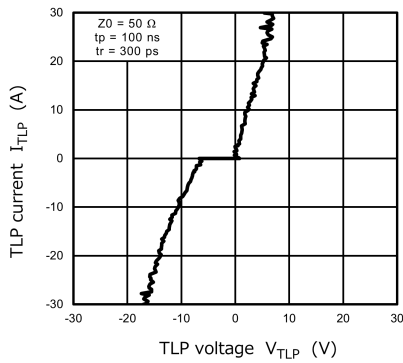

Fig. 10.4.1 $I_{TLP} - V_{TLP}$

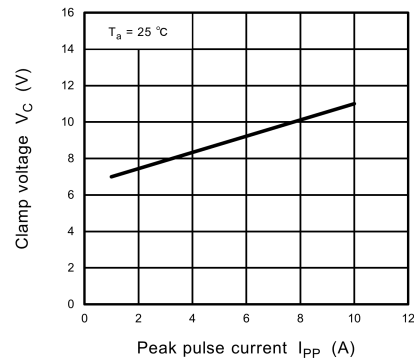
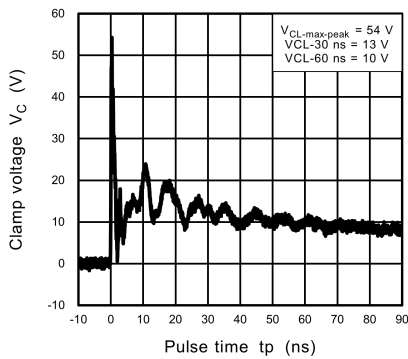
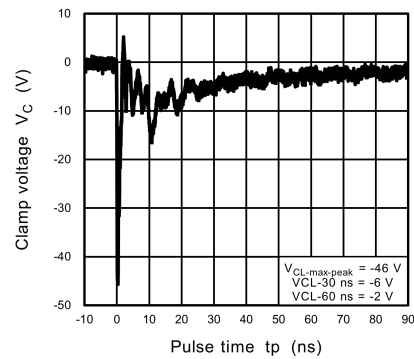

Fig. 10.4.2 $V_C - I_{PP}$



**Fig. 10.4.3 IEC61000-4-2
Clamp Waveform +8 kV**



**Fig. 10.4.4 IEC61000-4-2
Clamp Waveform -8 kV**

Note: The above characteristics curves are presented for reference only and not guaranteed by production test, unless otherwise noted.

Refer to Fig.10.22.1, Fig.10.22.2 for peak pulse current(V_C-I_{PP}) and clamp waveform measurement circuit.

10.5. MSZ7V5 Characteristics Curves(Note)

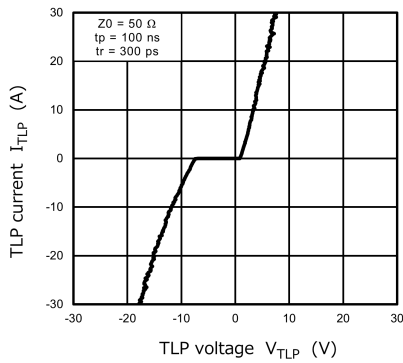

Fig. 10.5.1 $I_{TLP} - V_{TLP}$

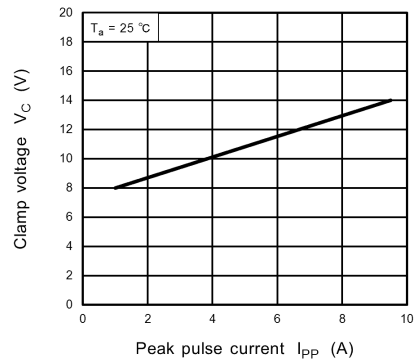
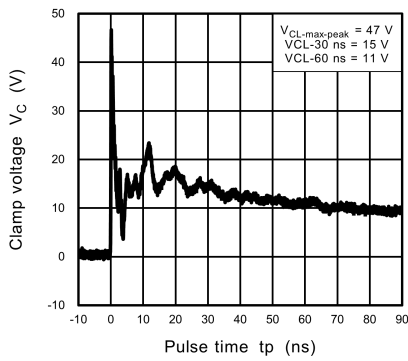
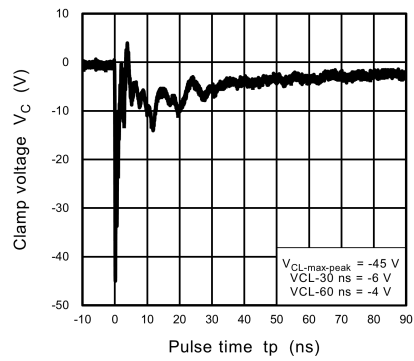

Fig. 10.5.2 $V_C - I_{PP}$



**Fig. 10.5.3 IEC61000-4-2
Clamp Waveform +8 kV**



**Fig. 10.5.4 IEC61000-4-2
Clamp Waveform -8 kV**

Note: The above characteristics curves are presented for reference only and not guaranteed by production test, unless otherwise noted.

Refer to Fig.10.22.1, Fig.10.22.2 for peak pulse current(V_C-I_{PP}) and clamp waveform measurement circuit.

10.6. MSZ8V2 Characteristics Curves(Note)

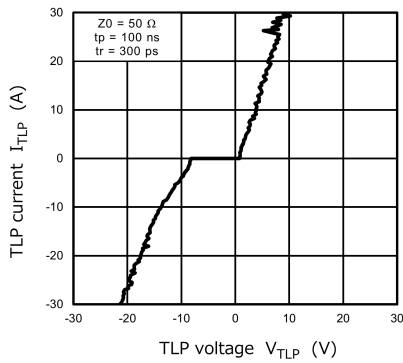

Fig. 10.6.1 $I_{TLP} - V_{TLP}$

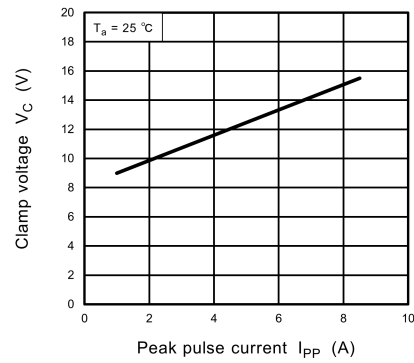
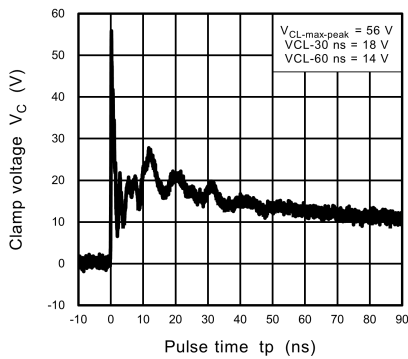
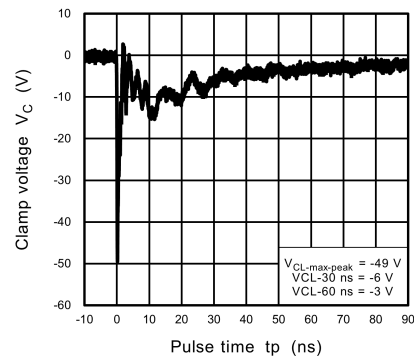

Fig. 10.6.2 $V_C - I_{PP}$



**Fig. 10.6.3 IEC61000-4-2
Clamp Waveform +8 kV**



**Fig. 10.6.4 IEC61000-4-2
Clamp Waveform -8 kV**

Note: The above characteristics curves are presented for reference only and not guaranteed by production test, unless otherwise noted.

Refer to Fig.10.22.1, Fig.10.22.2 for peak pulse current(V_C-I_{PP}) and clamp waveform measurement circuit.

10.7. MSZ9V1 Characteristics Curves(Note)

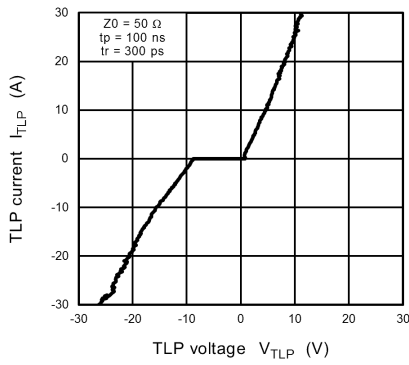

Fig. 10.7.1 $I_{TLP} - V_{TLP}$

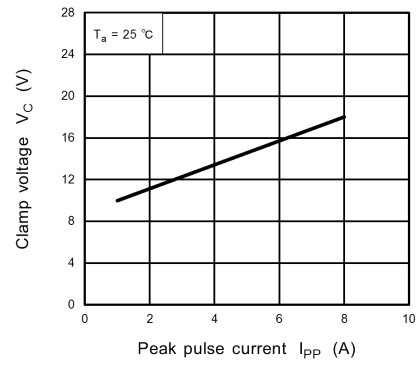
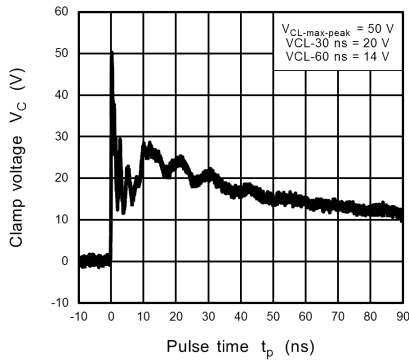
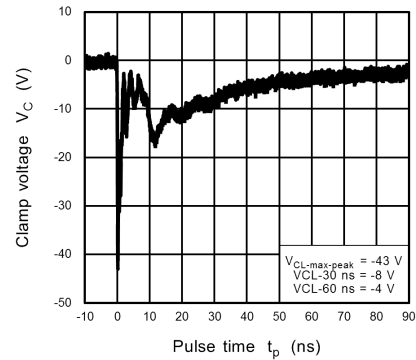

Fig. 10.7.2 $V_C - I_{PP}$



**Fig. 10.7.3 IEC61000-4-2
Clamp Waveform +8 kV**



**Fig. 10.7.4 IEC61000-4-2
Clamp Waveform -8 kV**

Note: The above characteristics curves are presented for reference only and not guaranteed by production test, unless otherwise noted.

Refer to Fig.10.22.1, Fig.10.22.2 for peak pulse current(V_C-I_{PP}) and clamp waveform measurement circuit.

10.8. MSZ10V Characteristics Curves(Note)

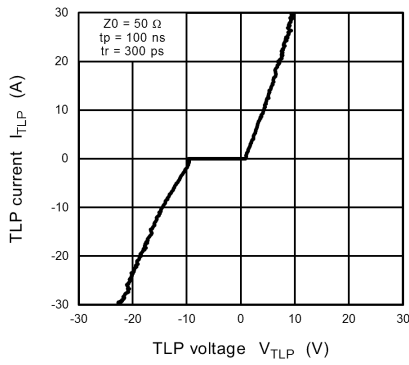

Fig. 10.8.1 $I_{TLP} - V_{TLP}$

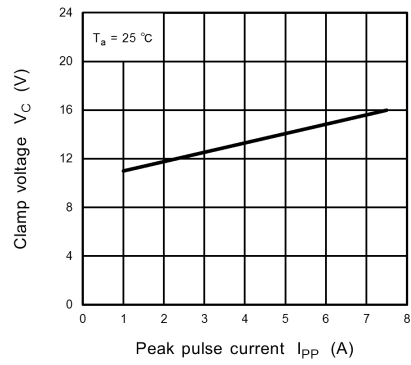
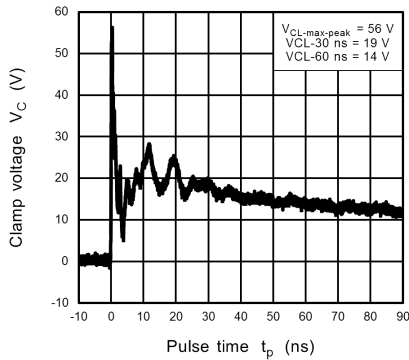
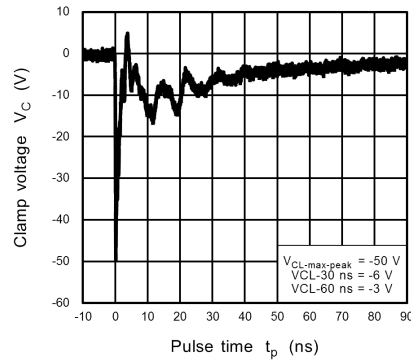

Fig. 10.8.2 $V_C - I_{PP}$



**Fig. 10.8.3 IEC61000-4-2
Clamp Waveform +8 kV**



**Fig. 10.8.4 IEC61000-4-2
Clamp Waveform -8 kV**

Note: The above characteristics curves are presented for reference only and not guaranteed by production test, unless otherwise noted.

Refer to Fig.10.22.1, Fig.10.22.2 for peak pulse current(V_C-I_{PP}) and clamp waveform measurement circuit.

10.9. MSZ11V Characteristics Curves(Note)

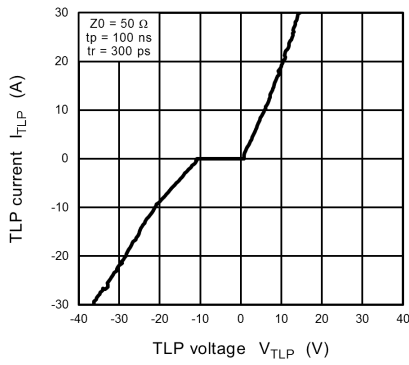

Fig. 10.9.1 $I_{TLP} - V_{TLP}$

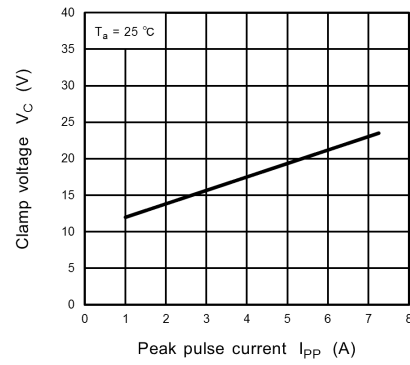
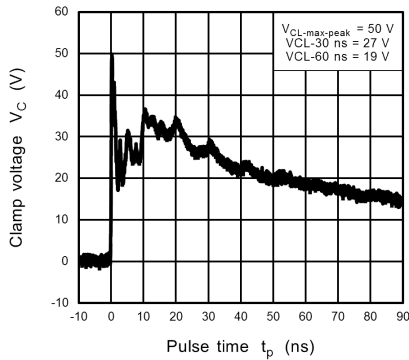
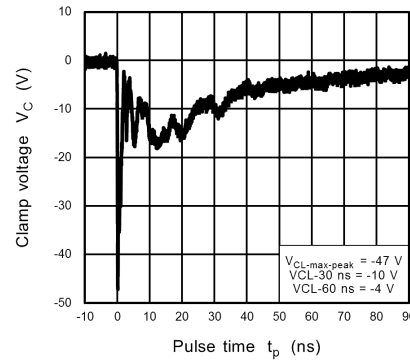

Fig. 10.9.2 $V_C - I_{PP}$



**Fig. 10.9.3 IEC61000-4-2
Clamp Waveform +8 kV**



**Fig. 10.9.4 IEC61000-4-2
Clamp Waveform -8 kV**

Note: The above characteristics curves are presented for reference only and not guaranteed by production test, unless otherwise noted.

Refer to Fig.10.22.1, Fig.10.22.2 for peak pulse current(V_C-I_{PP}) and clamp waveform measurement circuit.

10.10. MSZ12V Characteristics Curves(Note)

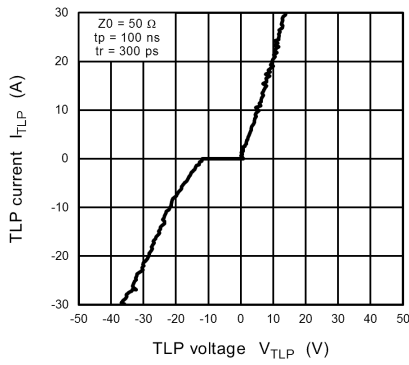

Fig. 10.10.1 $I_{TLP} - V_{TLP}$

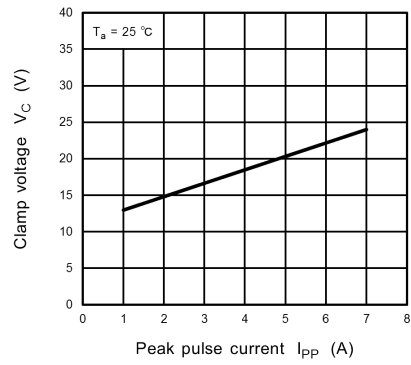
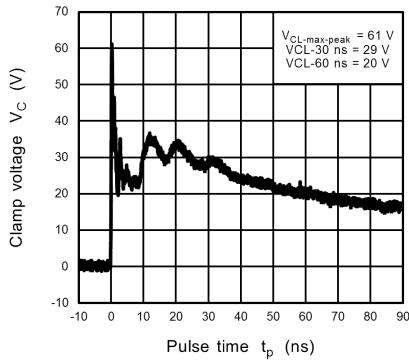
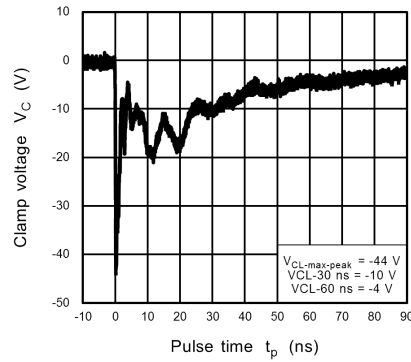

Fig. 10.10.2 $V_C - I_{PP}$



**Fig. 10.10.3 IEC61000-4-2
Clamp Waveform +8 kV**



**Fig. 10.10.4 IEC61000-4-2
Clamp Waveform -8 kV**

Note: The above characteristics curves are presented for reference only and not guaranteed by production test, unless otherwise noted.

Refer to Fig.10.22.1, Fig.10.22.2 for peak pulse current(V_C-I_{PP}) and clamp waveform measurement circuit.

10.11. MSZ13V Characteristics Curves(Note)

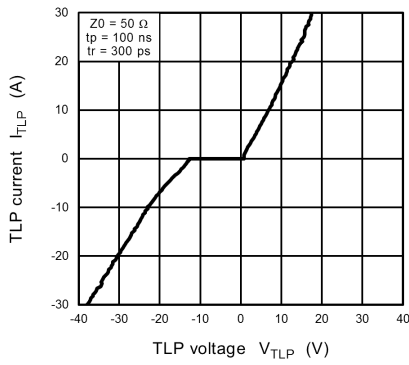

Fig. 10.11.1 $I_{TLP} - V_{TLP}$

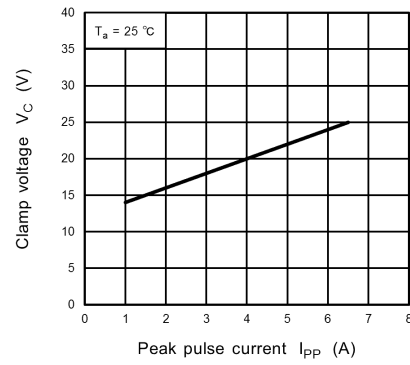
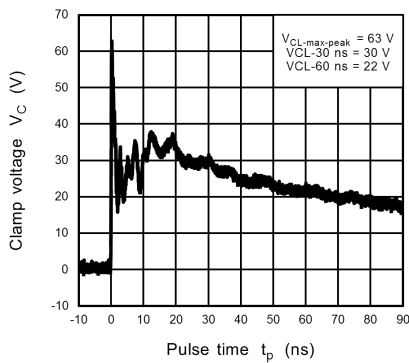
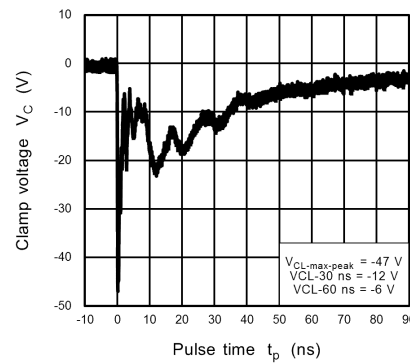

Fig. 10.11.2 $V_C - I_{PP}$



**Fig. 10.11.3 IEC61000-4-2
Clamp Waveform +8 kV**



**Fig. 10.11.4 IEC61000-4-2
Clamp Waveform -8 kV**

Note: The above characteristics curves are presented for reference only and not guaranteed by production test, unless otherwise noted.

Refer to Fig.10.22.1, Fig.10.22.2 for peak pulse current(V_C-I_{PP}) and clamp waveform measurement circuit.

10.12. MSZ15V Characteristics Curves(Note)

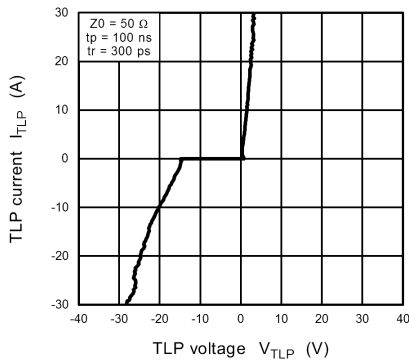

Fig. 10.12.1 $I_{TLP} - V_{TLP}$

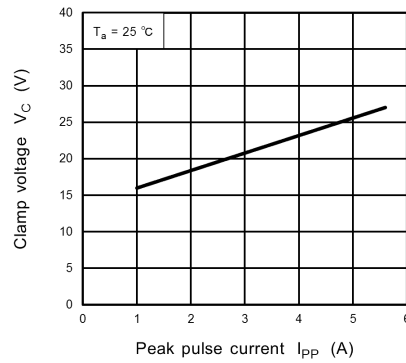
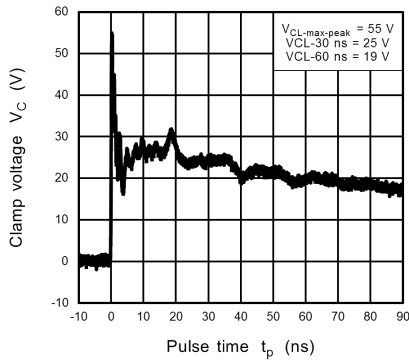
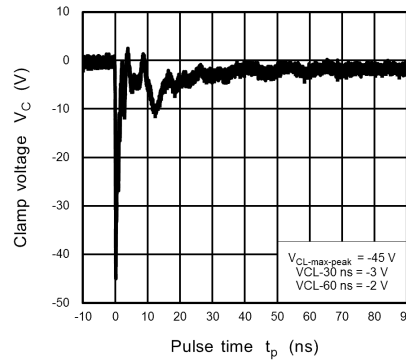

Fig. 10.12.2 $V_C - I_{PP}$



**Fig. 10.12.3 IEC61000-4-2
Clamp Waveform +8 kV**



**Fig. 10.12.4 IEC61000-4-2
Clamp Waveform -8 kV**

Note: The above characteristics curves are presented for reference only and not guaranteed by production test, unless otherwise noted.

Refer to Fig.10.22.1, Fig.10.22.2 for peak pulse current(V_C-I_{PP}) and clamp waveform measurement circuit.

10.13. MSZ16V Characteristics Curves(Note)

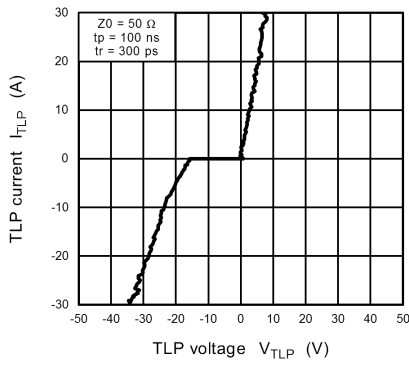

Fig. 10.13.1 $I_{TLP} - V_{TLP}$

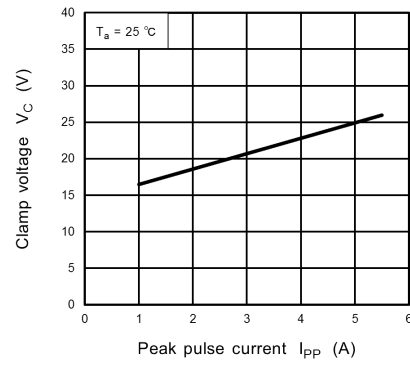
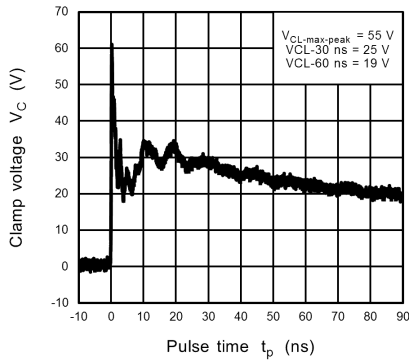
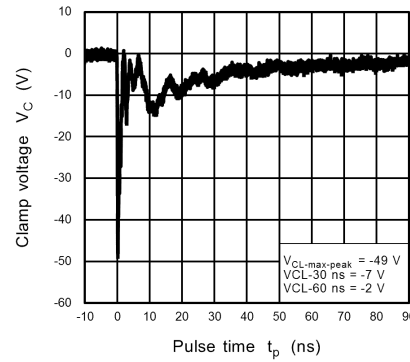

Fig. 10.13.2 $V_C - I_{PP}$



**Fig. 10.13.3 IEC61000-4-2
Clamp Waveform +8 kV**



**Fig. 10.13.4 IEC61000-4-2
Clamp Waveform -8 kV**

Note: The above characteristics curves are presented for reference only and not guaranteed by production test, unless otherwise noted.

Refer to Fig.10.22.1, Fig.10.22.2 for peak pulse current(V_C - I_{PP}) and clamp waveform measurement circuit.

10.14. MSZ18V Characteristics Curves(Note)

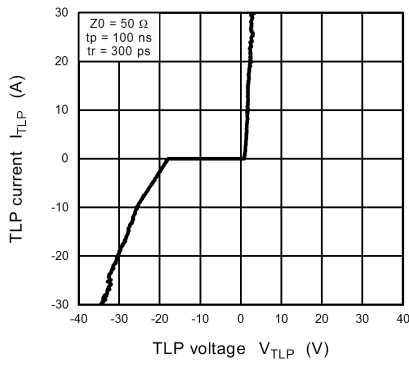

Fig. 10.14.1 $I_{TLP} - V_{TLP}$

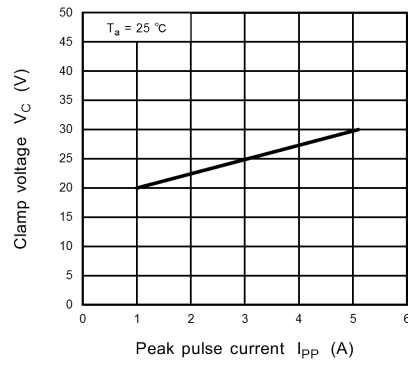
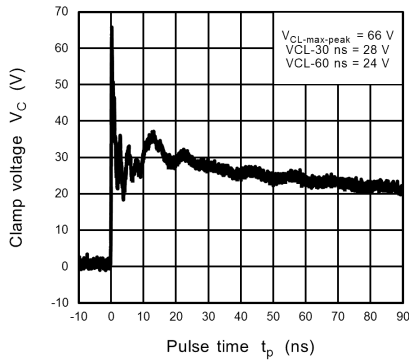
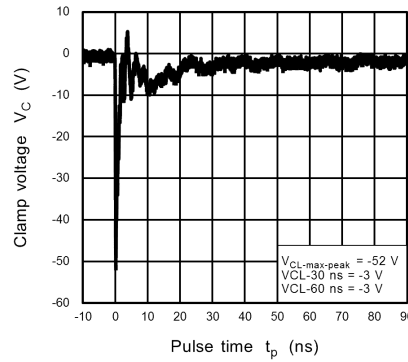

Fig. 10.14.2 $V_C - I_{PP}$



**Fig. 10.14.3 IEC61000-4-2
Clamp Waveform +8 kV**



**Fig. 10.14.4 IEC61000-4-2
Clamp Waveform -8 kV**

Note: The above characteristics curves are presented for reference only and not guaranteed by production test, unless otherwise noted.

Refer to Fig.10.22.1, Fig.10.22.2 for peak pulse current(V_C-I_{PP}) and clamp waveform measurement circuit.

10.15. MSZ20V Characteristics Curves(Note)

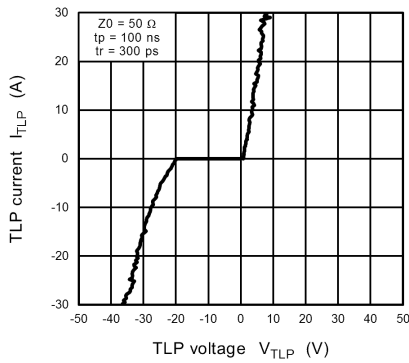

Fig. 10.15.1 $I_{TLP} - V_{TLP}$

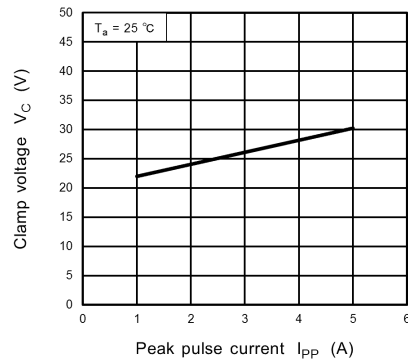
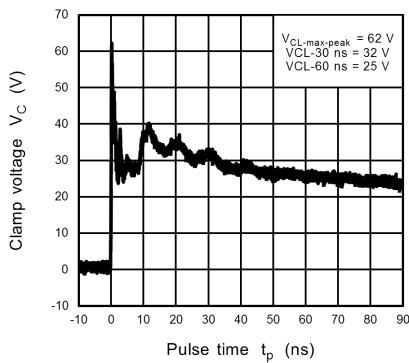
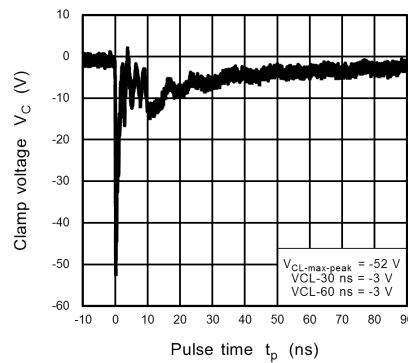

Fig. 10.15.2 $V_C - I_{PP}$



**Fig. 10.15.3 IEC61000-4-2
Clamp Waveform +8 kV**



**Fig. 10.15.4 IEC61000-4-2
Clamp Waveform -8 kV**

Note: The above characteristics curves are presented for reference only and not guaranteed by production test, unless otherwise noted.

Refer to Fig.10.22.1, Fig.10.22.2 for peak pulse current(V_C-I_{PP}) and clamp waveform measurement circuit.

10.16. MSZ22V Characteristics Curves(Note)

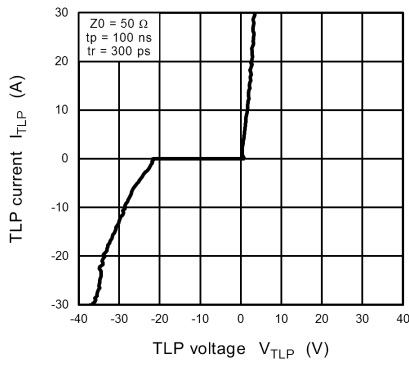

Fig. 10.16.1 $I_{TLP} - V_{TLP}$

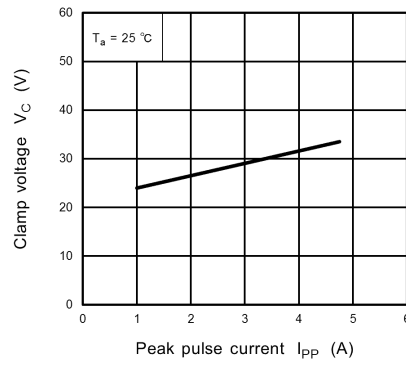
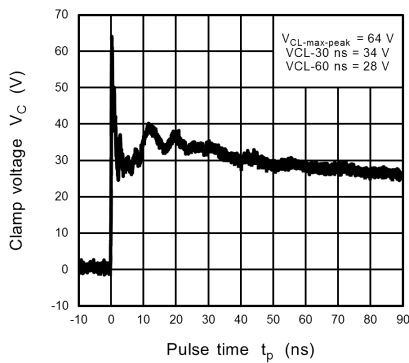
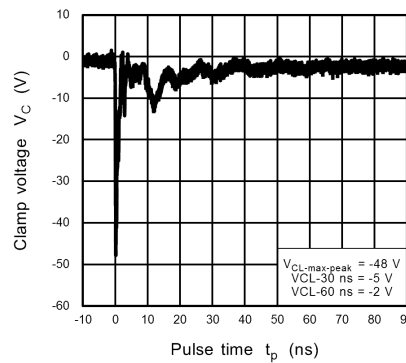

Fig. 10.16.2 $V_C - I_{PP}$



**Fig. 10.16.3 IEC61000-4-2
Clamp Waveform +8 kV**



**Fig. 10.16.4 IEC61000-4-2
Clamp Waveform -8 kV**

Note: The above characteristics curves are presented for reference only and not guaranteed by production test, unless otherwise noted.

Refer to Fig.10.22.1, Fig.10.22.2 for peak pulse current(V_C-I_{PP}) and clamp waveform measurement circuit.

10.17. MSZ24V Characteristics Curves(Note)

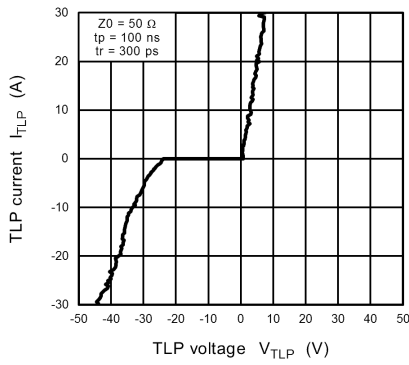

Fig. 10.17.1 $I_{TLP} - V_{TLP}$

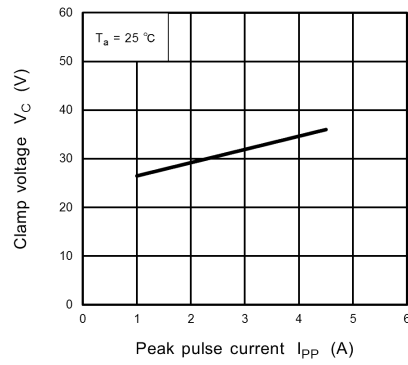
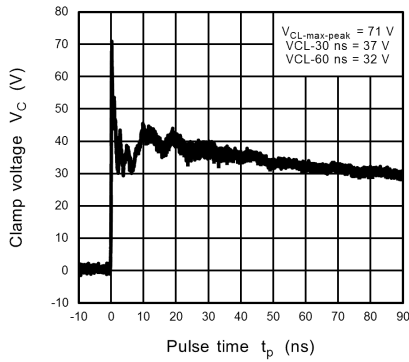
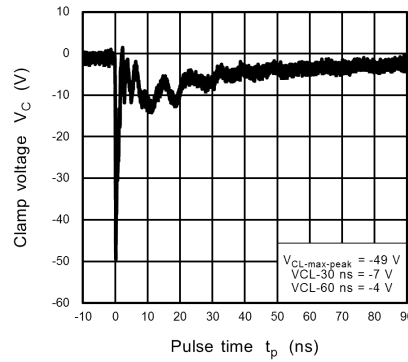

Fig. 10.17.2 $V_C - I_{PP}$



**Fig. 10.17.3 IEC61000-4-2
Clamp Waveform +8 kV**



**Fig. 10.17.4 IEC61000-4-2
Clamp Waveform -8 kV**

Note: The above characteristics curves are presented for reference only and not guaranteed by production test, unless otherwise noted.

Refer to Fig.10.22.1, Fig.10.22.2 for peak pulse current(V_C - I_{PP}) and clamp waveform measurement circuit.

10.18. MSZ27V Characteristics Curves(Note)

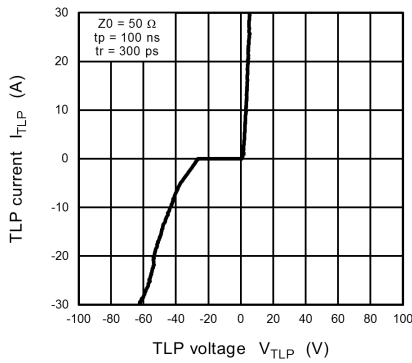

Fig. 10.18.1 $I_{TLP} - V_{TLP}$

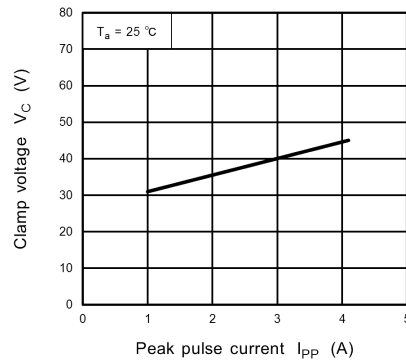
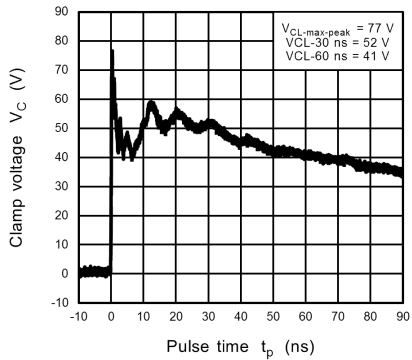
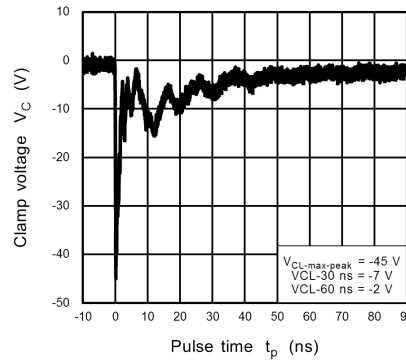

Fig. 10.18.2 $V_C - I_{PP}$



**Fig. 10.18.3 IEC61000-4-2
Clamp Waveform +8 kV**



**Fig. 10.18.4 IEC61000-4-2
Clamp Waveform -8 kV**

Note: The above characteristics curves are presented for reference only and not guaranteed by production test, unless otherwise noted.

Refer to Fig.10.22.1, Fig.10.22.2 for peak pulse current(V_C-I_{PP}) and clamp waveform measurement circuit.

10.19. MSZ30V Characteristics Curves(Note)

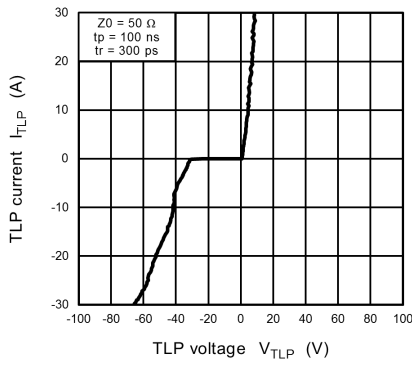

Fig. 10.19.1 $I_{TLP} - V_{TLP}$

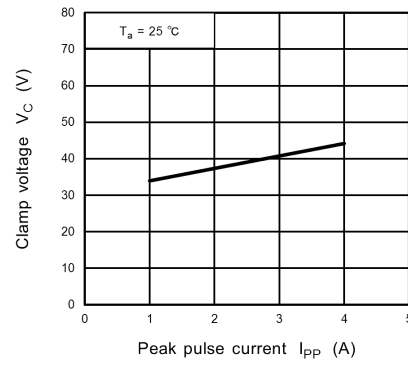
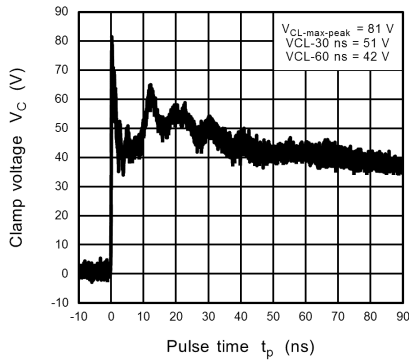
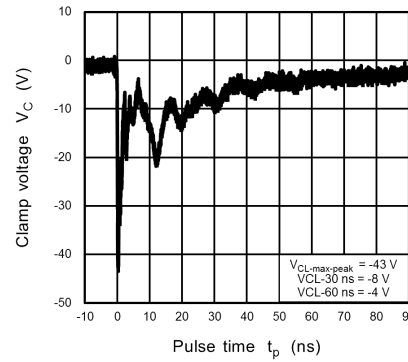

Fig. 10.19.2 $V_C - I_{PP}$



**Fig. 10.19.3 IEC61000-4-2
Clamp Waveform +8 kV**



**Fig. 10.19.4 IEC61000-4-2
Clamp Waveform -8 kV**

Note: The above characteristics curves are presented for reference only and not guaranteed by production test, unless otherwise noted.

Refer to Fig.10.22.1, Fig.10.22.2 for peak pulse current(V_C - I_{PP}) and clamp waveform measurement circuit.

10.20. MSZ33V Characteristics Curves(Note)

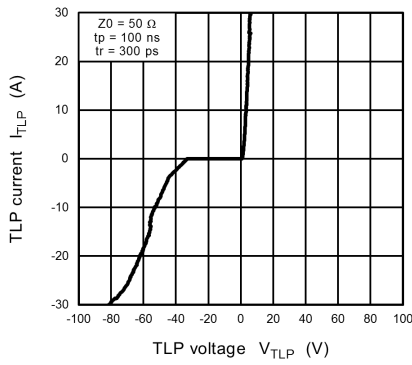

Fig. 10.20.1 $I_{TLP} - V_{TLP}$

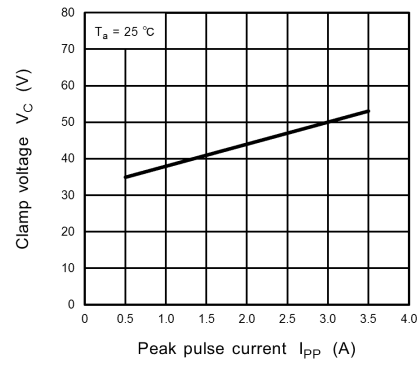
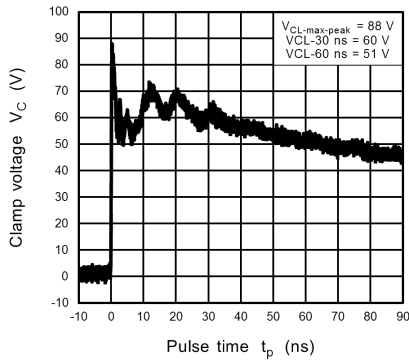
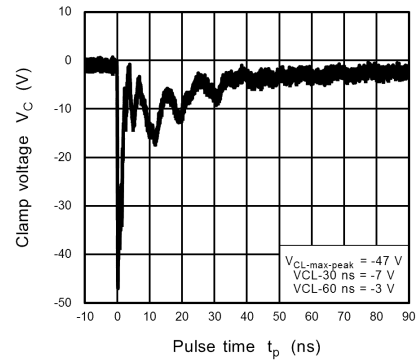

Fig. 10.20.2 $V_C - I_{PP}$



**Fig. 10.20.3 IEC61000-4-2
Clamp Waveform +8 kV**



**Fig. 10.20.4 IEC61000-4-2
Clamp Waveform -8 kV**

Note: The above characteristics curves are presented for reference only and not guaranteed by production test, unless otherwise noted.

Refer to Fig.10.22.1, Fig.10.22.2 for peak pulse current(V_C-I_{PP}) and clamp waveform measurement circuit.

10.21. MSZ36V Characteristics Curves(Note)

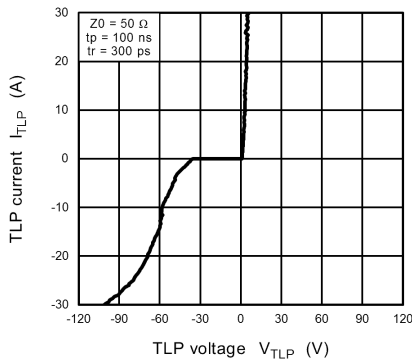

Fig. 10.21.1 $I_{TLP} - V_{TLP}$

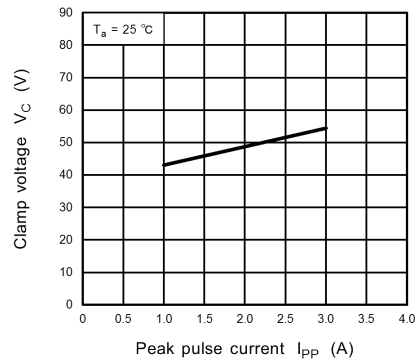

Fig. 10.21.2 $V_C - I_{PP}$

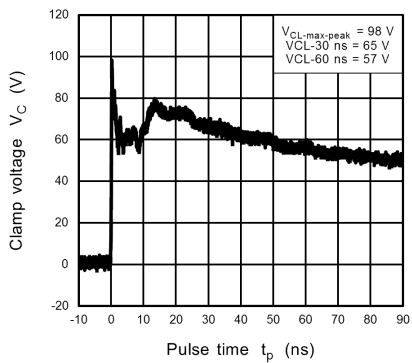

Fig. 10.21.3 IEC61000-4-2
Clamp Waveform +8 kV

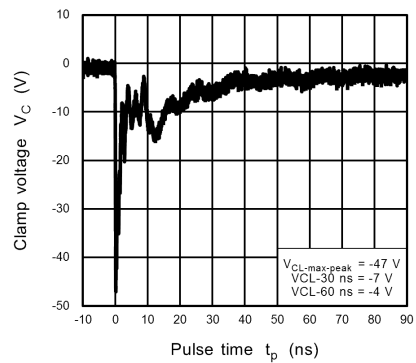

Fig. 10.21.4 IEC61000-4-2
Clamp Waveform -8 kV

Note: The above characteristics curves are presented for reference only and not guaranteed by production test, unless otherwise noted.

Refer to Fig.10.22.1, Fig.10.22.2 for peak pulse current(V_C-I_{PP}) and clamp waveform measurement circuit.

10.22. V_C-I_{PP} Peak Pulse and Clamp waveform measurement circuit

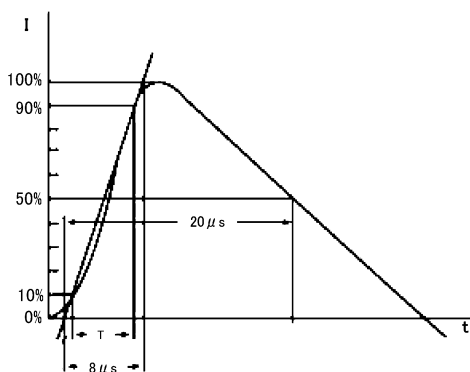

Fig. 10.22.1 V_C-I_{PP} Peak Pulse Current
(according to IEC61000-4-5 8/20 μ s pulse)

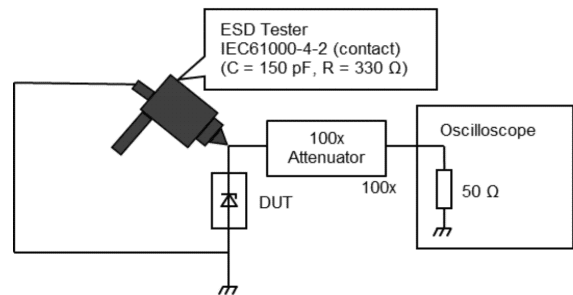
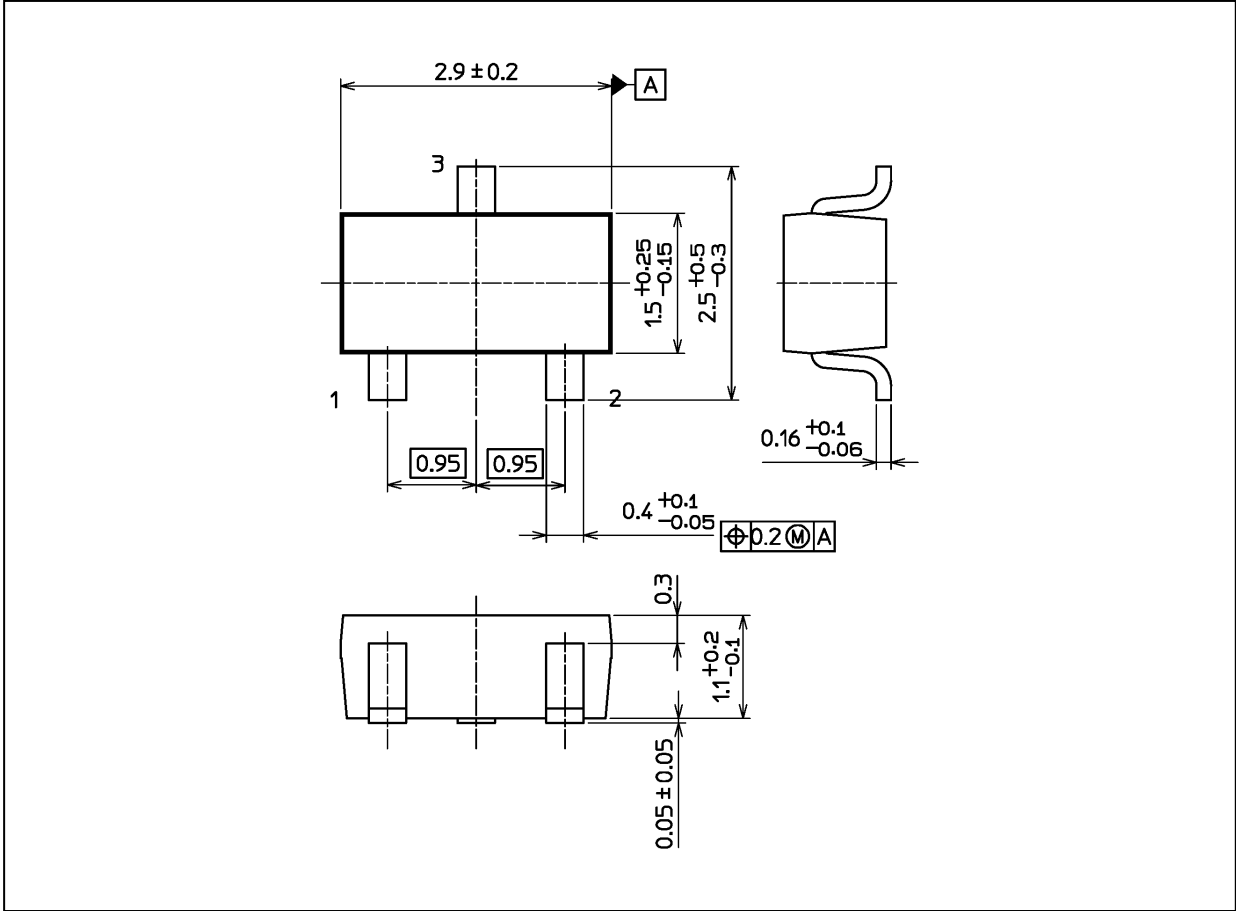

Fig. 10.22.2 Clamp waveform measurement
circuit (according to IEC61000-4-2)

Package Dimensions

Unit: mm



Weight: 12 mg (typ.)

Package Name(s)
Nickname: S-Mini

RESTRICTIONS ON PRODUCT USE

Toshiba Corporation and its subsidiaries and affiliates are collectively referred to as "TOSHIBA".

Hardware, software and systems described in this document are collectively referred to as "Product".

- TOSHIBA reserves the right to make changes to the information in this document and related Product without notice.
- This document and any information herein may not be reproduced without prior written permission from TOSHIBA. Even with TOSHIBA's written permission, reproduction is permissible only if reproduction is without alteration/omission.
- Though TOSHIBA works continually to improve Product's quality and reliability, Product can malfunction or fail. Customers are responsible for complying with safety standards and for providing adequate designs and safeguards for their hardware, software and systems which minimize risk and avoid situations in which a malfunction or failure of Product could cause loss of human life, bodily injury or damage to property, including data loss or corruption. Before customers use the Product, create designs including the Product, or incorporate the Product into their own applications, customers must also refer to and comply with (a) the latest versions of all relevant TOSHIBA information, including without limitation, this document, the specifications, the data sheets and application notes for Product and the precautions and conditions set forth in the "TOSHIBA Semiconductor Reliability Handbook" and (b) the instructions for the application with which the Product will be used with or for. Customers are solely responsible for all aspects of their own product design or applications, including but not limited to (a) determining the appropriateness of the use of this Product in such design or applications; (b) evaluating and determining the applicability of any information contained in this document, or in charts, diagrams, programs, algorithms, sample application circuits, or any other referenced documents; and (c) validating all operating parameters for such designs and applications. **TOSHIBA ASSUMES NO LIABILITY FOR CUSTOMERS' PRODUCT DESIGN OR APPLICATIONS.**
- **PRODUCT IS NEITHER INTENDED NOR WARRANTED FOR USE IN EQUIPMENTS OR SYSTEMS THAT REQUIRE EXTRAORDINARILY HIGH LEVELS OF QUALITY AND/OR RELIABILITY, AND/OR A MALFUNCTION OR FAILURE OF WHICH MAY CAUSE LOSS OF HUMAN LIFE, BODILY INJURY, SERIOUS PROPERTY DAMAGE AND/OR SERIOUS PUBLIC IMPACT ("UNINTENDED USE").** Except for specific applications as expressly stated in this document, Unintended Use includes, without limitation, equipment used in nuclear facilities, equipment used in the aerospace industry, Class 3 medical devices, equipment used for automobiles, and military vehicles and munitions. **IF YOU USE PRODUCT FOR UNINTENDED USE, TOSHIBA ASSUMES NO LIABILITY FOR PRODUCT.** For details, please contact your TOSHIBA sales representative or contact us via our website.
- Do not disassemble, analyze, reverse-engineer, alter, modify, translate or copy Product, whether in whole or in part.
- Product shall not be used for or incorporated into any products or systems whose manufacture, use, or sale is prohibited under any applicable laws or regulations.
- The information contained herein is presented only as guidance for Product use. No responsibility is assumed by TOSHIBA for any infringement of patents or any other intellectual property rights of third parties that may result from the use of Product. No license to any intellectual property right is granted by this document, whether express or implied, by estoppel or otherwise.
- **ABSENT A WRITTEN SIGNED AGREEMENT, EXCEPT AS PROVIDED IN THE RELEVANT TERMS AND CONDITIONS OF SALE FOR PRODUCT, AND TO THE MAXIMUM EXTENT ALLOWABLE BY LAW, TOSHIBA (1) ASSUMES NO LIABILITY WHATSOEVER, INCLUDING WITHOUT LIMITATION, INDIRECT, CONSEQUENTIAL, SPECIAL, OR INCIDENTAL DAMAGES OR LOSS, INCLUDING WITHOUT LIMITATION, LOSS OF PROFITS, LOSS OF OPPORTUNITIES, BUSINESS INTERRUPTION AND LOSS OF DATA, AND (2) DISCLAIMS ANY AND ALL EXPRESS OR IMPLIED WARRANTIES AND CONDITIONS RELATED TO SALE, USE OF PRODUCT, OR INFORMATION, INCLUDING WARRANTIES OR CONDITIONS OF MERCHANTABILITY, FITNESS FOR A PARTICULAR PURPOSE, ACCURACY OF INFORMATION, OR NONINFRINGEMENT.**
- Do not use or otherwise make available Product or related software or technology for any military purposes, including without limitation, for the design, development, use, stockpiling or manufacturing of nuclear, chemical, or biological weapons or missile technology products (mass destruction weapons). Product and related software and technology may be controlled under the applicable export laws and regulations including, without limitation, the Japanese Foreign Exchange and Foreign Trade Law and the U.S. Export Administration Regulations. Export and re-export of Product or related software or technology are strictly prohibited except in compliance with all applicable export laws and regulations.
- Please contact your TOSHIBA sales representative for details as to environmental matters such as the RoHS compatibility of Product. Please use Product in compliance with all applicable laws and regulations that regulate the inclusion or use of controlled substances, including without limitation, the EU RoHS Directive. **TOSHIBA ASSUMES NO LIABILITY FOR DAMAGES OR LOSSES OCCURRING AS A RESULT OF NONCOMPLIANCE WITH APPLICABLE LAWS AND REGULATIONS.**