

CMOS Digital Integrated Circuit Silicon Monolithic

TC358770AXBG/TC358777XBG

Mobile Peripheral Devices

Overview

This Functional Specification defines operation of TC358770AXBG / TC358777XBG chip, which concatenates two DSISM streams of video packets, one from each DSI link into a single DisplayPortTM video stream.

The only difference between TC358770AXBG and TC358777XBG is the package size. TC358770AXBG housed in a 5.0 mm by 5.0 mm size package with 0.4 mm ball pitch. While TC358777XBG housed in a 7.0 mm by 7.0 mm size package with 0.65 mm ball pitch.

TC358770AXBG / TC358777XBG exhibits two independent 4-data lane DSI receivers and one 4-lane DisplayPortTM transmitter. Each DSI link data lane can receive data up to 1 Gbps/lane, with up to 8 Gbps total input data rate. Each DSI receiver link can activate 0-, 1-, 2-, 3- or 4-data lanes independently. DP main link can toggle bit rate at either 1.62 or 2.7 Gbps per lane, with maximum output data rate at 8.64 Gbps. DP transmitter is able to operate with 1-, 2 or 4-lanes in its main link.

The target application is for high resolution DisplayPortTM panels, whose bandwidth requirement cannot be met by a single 4-data lane DSI link @4 Gbps. TC358770AXBG is an ideal bridge chip which enables application processors, or hosts, with dual DSI links to drive up to 2560 x 2048 x 24 (or 18) DisplayPortTM panels @60fps.

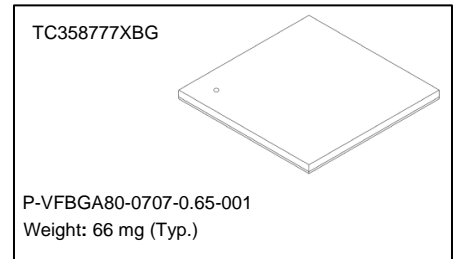
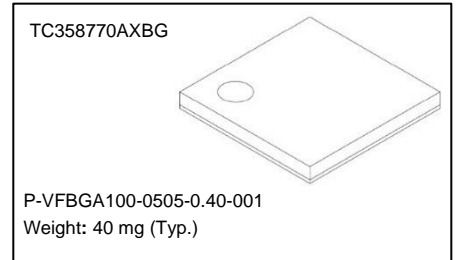

Features

- TC358770AXBG / TC358777XBG follows the following standards:
 - ✧ MIPI[®] DSISM version 1.02, Jan 2010.
 - ✧ MIPI[®] D-PHYSM version 1.0, May 2009.
 - ✧ VESA[®] DisplayPortTM Standard version 1.1a, Jan. 11 2008.
- DSI Receiver
 - ✧ Dual 4-Data Lane DSI Link with Bi-direction support at Data Lane 0, it can be used in 1-, 2-, 3- or 4-data lane configuration.
 - ✧ Maximum speed at 1 Gbps/lane.
 - ✧ Video input data formats: RGB-565, RGB-666 and RGB-888.
 - ✧ New DSI V1.02 Data Type, 16-bit YCbCr 422, is supported.
 - ✧ Interlaced video mode is not supported.
 - ✧ Provide path for DSI host/transmitter to control TC358770AXBG / TC358777XBG and its attached panel.
 - ✧ DSI Link High Speed clock, DSIClk or an external clock, RefClk, is required before programming TC358770AXBG.
- DisplayPortTM Source/Transmitter
 - ✧ VESA[®] DisplayPortTM Rev 1.1a Standard.
 - Bit Rate @ 1.62 or 2.7 Gbps, Voltage Swing @0.4, 0.6, 0.8 or 1.2 V, Pre-Emphasis Level @0, 3.5 or 6dB.
 - There are four lanes available in DP main Link, which can operate in 1-, 2- or 4-lane configuration.
 - AUX channel with nominal bit rate at 1 Mbps.
 - ✧ After receiving DSI link burst data, TC358770AXBG / TC358777XBG retimes video data to DP panel's pixel clock for Synchronous (to DisplayPortTM link symbol clock, LSClk) Clock Mode operation.
 - ✧ SSCG with up to 30 kHz modulation to reduce EMI.
 - ✧ Built in PRBS7 Generator to test DisplayPortTM Link without DSI input.
 - ✧ Built in Color Bar Generator to verify DisplayPortTM protocol.
 - ✧ Not support HDCP.
 - ✧ Secure ASSR (Alternate Scrambler Seed Reset) support for eDP panels
 - System designer connects ASSR_DisablePad to an inner ring VSS_IO pad, e.g. pad E4, to enable eDP panels and ASSR

- Drive ASSR_DisablePad with an inner ring VDDS pad, e.g. pad D5, for using DP panels and disable ASSR
- System software read Revision ID field, 0x0500[7:0]:
 - 0x01 indicates eDP panels are used, DPCD register bit 0x0010A[0] of eDP panel should be set.
 - 0x03 assumes DP panels are connected, DPCD register bit 0x0010A[0] of DP panel should Not be set.
- I²C Slave Port
 - ✧ Support for normal (100 kHz) and fast (400 kHz) modes.
 - ✧ External I²C master can access TC358770AXBG / TC358777XBG internal registers via this port.
 - ✧ Address auto increment is supported.
 - ✧ TC358770AXBG / TC358777XBG Slave Port address is 0x68, (binary 1101_000x) where x = 1 for read and x = 0 for write. The slave address can be changed to 0x0F (binary 0001_111x) by tying pin SPI_SS/I2C_ADR_SEL to high.
- SPI Slave Interface
 - ✧ Slave select pin supported.
 - ✧ Clock Polarity and Phase as per SPI MODE0 (polarity = 0, phase = 0).
 - ✧ Transfer Frame size of 48 bits.
 - ✧ Maximum clock speed is up to 30 MHz.
- Audio Interface
 - ✧ Support either I2S or TDM (Time Division Multiplex) mode.
 - ✧ TDM mode can support 2, 4, 6 and 8 channel of audio data.
 - ✧ Support 16, 18, 20 or 24-bit PCM audio data word.
 - ✧ Sample frequency, fs, supported: 32, 44.1, 48, 88.2, 96, 176.4 & 192 kHz.
 - ✧ 512 * fs audio oversample clock is required to generate accurate audio clock timestamps in order for the DisplayPort™ panel to recover audio clock correctly.
 - ✧ Ability to insert IEC60958 status bits and preamble bits per channel.
- Operation
 - ✧ Host programs TC358770AXBG / TC358777XBG either by using DSI link 0 (DSI0), I²C bus or SPI bus.
 - ✧ TC358770AXBG / TC358777XBG provides "mailbox registers," 20-bit AuxAddr and 16-byte AuxData, for Host to access DisplayPort™ Panel's DisplayPort™ Configuration Data, DPCD, registers.
- ✧ Host splits a video line data into two streams of DSI video packets. Host has two options to split the video line data:
 - Left-Right Side: Left (first) side video packet goes to DSI0 and Right side data to DSI1.
 - Even-Odd Group: Even (first) groups of pixels are transmitted in DSI0 while Odd ones are carried by DSI1.
 - The number of pixels per group is programmable; from 1 to 64.
 - The number of pixels per group and/or the number of groups in each video packet can be different between the two DSI links. This feature in connection with TC358770AXBG's capability to support configurable number of data lanes.
- It is recommended that host pack the split video line data into one video packet for each DSI link before transmitting. However, TC358770AXBG / TC358777XBG supports multiple DSI packets per horizontal line time as long as DSI link bandwidth is enough for the overhead.
- ✧ TC358770AXBG / TC358777XBG is responsible to generate video frame timing based on the register values set by the Host. Host does not have to care/generate video horizontal timings, such as Horizontal Front/Back Porch and Horizontal Pulse width. Host is responsible to send the video data packets to TC358770AXBG / TC358777XBG in time line-by-line and separated each line data by HSS.
 - Host is expected to send exactly one line of video data per horizontal sync period between the two DSI links.
 - Host is expected to start HSS₀, HSS packet of DSI0, and HSS₁, HSS packet of DSI1, either at "the same time" or with fixed delay/skew between them (HSS₀ earlier than that of HSS₁).
 - "The same time" means within +/- 5 clock cycles.
 - The time skew between the two DSI links' Hsync Start, HSS, packet cannot drift more than one video line time within one video frame period.
 - Host is recommended to use the same clock source to generate both DSI link clocks in order to prevent these two clocks from drifting away.
 - Otherwise, clock sources with 50 ppm accuracy are required.
- It is recommended that each DSI link sends HSS and video packets back-to-back. Host can insert variable length of blanking packet between HSS and video packets as long as the bandwidth is allowed.

- ◇ TC358770AXBG / TC358777XBG concatenates two (streams of) video packets, one (stream) from each DSI link, into a single DisplayPort™ video stream before transmitting it out to the panel.
- Clock Source:
 - ◇ An external reference clock, RefClk, is used to drive PLLs for generating DisplayPort's stream/pixel clock, StrmClk/PixelClk, and Link Symbol Clock, LSClk.
 - Support DisplayPort™ Synchronous (StrmClk and LSClk) Clock Mode.
 - Allowed RefClk Frequency Value: 13, 19.2, 26, 38.4 MHz.
 - ◇ Optionally, DSI DSIClk can be used/divided down to replace RefClk and drive PLLs used to generate the required clocks.
 - The divisor, from DSI ByteClk, can be either
 - 3 ($115.2/3 = 38.4$)
 - 4 ($104/4 = 26$)
 - 5 ($96/5 = 19.2$)
 - 9 ($117/9 = 13$)
- Power Supply
 - ◇ MIPI D-PHY and DP PHY: 1.2 V
 - ◇ Core: 1.2 V
 - ◇ DP-PHY: 1.8 V
 - ◇ I/O: 1.8 V to 3.3 V (all IO pins must be same power level)
 - ◇ HPD Input Pad 3.3 V
- Power Consumption (Typical Condition)
 - ◇ Sleep State, with RESX asserted
 - 12 mW
 - ◇ Typical Operation:
 - 2560 × 1440 × 24@60fps
 - Dual DSIRx, each link @3.7 Gbps
 - 31 mW for both Links
 - Core
 - 165 mW
 - DP Tx (2.7 Gbps Link speed @4 lanes, 0.4 V Swing without Pre-Emphasis)
 - 168.5 mW
 - Total = 364.5 mW

Table of contents

REFERENCES.....	5
1. Introduction.....	6
2. Features	8
3. External Pins	11
3.1. TC358770AXBG Pin Layout.....	11
3.2. TC358777XBG Pin Layout	12
3.3. TC358770AXBG Pinout Description	13
3.4. TC358777XBG Pinout Description.....	15
4. Package	17
5. Electrical characteristics.....	19
5.1. Absolute Maximum Ratings.....	19
5.2. Operating Condition.....	19
5.3. DC Electrical Specification	19
6. Revision History	20
RESTRICTIONS ON PRODUCT USE.....	21

List of Figures

Figure 1.1 TC358770AXBG / TC358777XBG in System Application.....	7
Figure 1.2 TC358770AXBG / TC358777XBG Block Diagram and Functional.....	7
Figure 3.1 TC358770AXBG Chip Pin Layout (Top view)	11
Figure 3.2 TC358777XBG Chip Pin Layout (Top view).....	12
Figure 4.1 TC358770AXBG Package Dimension.....	17
Figure 4.2 TC358777XBG Package Dimension	18

List of Tables

Table 3.1 TC358770AXBG Functional Signal List.....	13
Table 3.2 Pin Count Summary	14
Table 3.3 TC358777XBG Functional Signal List	15
Table 3.4 Pin Count Summary	16
Table 4.1 TC358770AXBG Package Details	17
Table 4.2 TC358777XBG Package Details	18
Table 6.1 Revision History	20

REFERENCES

1. MIPI® D-PHYSM, "MIPI Alliance Specification for D-PHY Version 1.00.00 14-May-2009"
2. MIPI Alliance Standard for DSI Version 1.02.00 – 28 June 2010
3. VESA® DisplayPort™ Standard (Version 1, Revision 1a January 11, 2008)
4. VESA® Embedded DisplayPort™ (eDP) Standard (Version 1.1 October 23, 2009)
5. I²C bus specification, version 2.1, January 2000, Philips Semiconductor

- MIPI® is a registered service mark of MIPI Alliance, Inc. DSISM and D-PHYSM are service marks of MIPI Alliance, Inc.
- DisplayPort™ is a trademark owned by the Video Electronics Standards Association (VESA®) in the United States and other countries.
- Other company names, product names, and service names may be trademarks of their respective companies.

1. Introduction

This Functional Specification defines operation of TC358770AXBG / TC358777XBG chip, which concatenates two DSI streams of video packets, one from each DSI link into a single DisplayPort™ video stream.

The only difference between TC358770AXBG and TC358777XBG is the package size. TC358770AXBG housed in a 5.0 mm by 5.0 mm size package with 0.4 mm ball pitch. While TC358777XBG housed in a 7.0 mm by 7.0 mm size package with 0.65 mm ball pitch.

TC358770AXBG / TC358777XBG exhibits two independent 4-data lane DSI receivers and one 4-lane DisplayPort™ transmitter. Each DSI link data lane can receive data up to 1 Gbps/lane, with up to 8 Gbps total input data rate. Each DSI receiver link can activate 0-, 1-, 2-, 3- or 4-data lanes independently. DP main link can toggle bit rate at either 1.62 or 2.7 Gbps per lane, with maximum output data rate at 8.64 Gbps. DP transmitter is able to operate with 1-, 2 or 4-lanes in its main link.

The target application is for high resolution DisplayPort™ panels, whose bandwidth requirement cannot be met by a single 4-data lane DSI link @4 Gbps. TC358770AXBG is an ideal bridge chip which enables application processors, or hosts, with dual DSI links to drive up to 2560 × 2048 × 24 (or 18) DisplayPort™ panels @60fps.

DSI host controls/configures TC358770AXBG / TC358777XBG chip by using DSI's Generic Long Write packets. TC358770AXBG / TC358777XBG provides mail box registers for host to control (command) DisplayPort™ panel's DisplayPort™ Configuration Data, DPCD, registers. After host writes to these mail box registers, TC358770AXBG starts Aux channel bus cycles to communicate with the DisplayPort™ panel. TC358770AXBG / TC358777XBG supports both Aux native mode and I²C mapped mode.

TC358770AXBG / TC358777XBG supports bi-directional DSI link. Host can read TC358770AXBG's registers by using DSI's Generic Short Read (2 parameter) packets. The read data is returned to host via DSI's reverse direction Low Power packets in data lane 0. Host can also access the DPCD status registers of DisplayPort™ panel by issuing read commands via TC358770AXBG's mail box registers. The maximum read data length is limited to 8 bytes per DSI link read.

Host can also access TC358770AXBG's registers, and DP panel's DPCD registers, by using an I²C bus by addressing TC358770AXBG's slave address 0x68 (1101_000x). Either an external reference clock, RefClk, or DSI link's high speed, HS, clock needs to toggle before programming TC358770AXBG. RefClk is limited to 13, 19.2, 26 or 38.4 MHz only.

TC358770AXBG / TC358777XBG exhibits a SPI slave port, which provides host as third path to program its registers. Since SPI port shares the same pins as those of I²C's, only one slave port can be used by the Host. I²C slave port is active by default, asserting input pin SPI_I2C activates SPI interface. Please tie the unused input pins to ground.

Audio interface can accept I2S or Time Domain Multiplex, TDM, type of audio data. This audio data is packed as Secondary Data Packets which are mixed with video stream before routing out to DP panel via DP's main link. Host needs to provide a 512 * fs, audio sample clock frequency, clock in order for the DisplayPort™ Panel to recover audio clock precisely.

This document assumes that both DSI links use the same clock source to generate DSI links timing. The unintentional clock skews due to two clock sources used to generate DSI links' timing is discussed in "2 Features".

The target system diagram and TC358770AXBG / TC358777XBG block diagram are shown in Figure 1.1 and Figure 1.2, respectively.

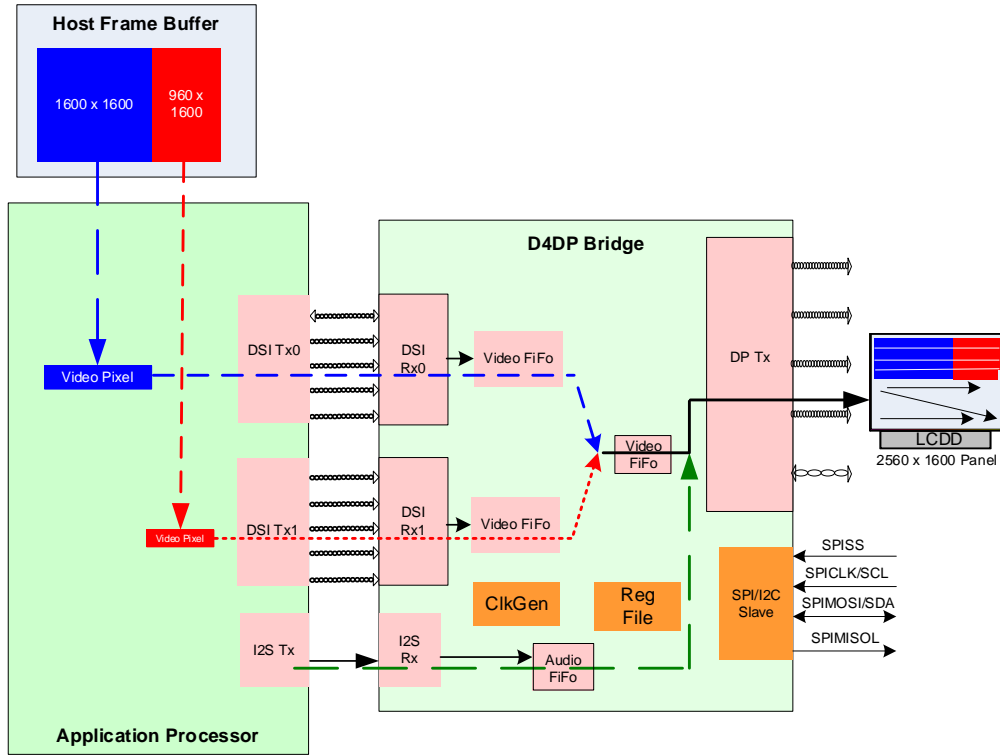

Figure 1.1 TC358770AXBG / TC358777XBG in System Application

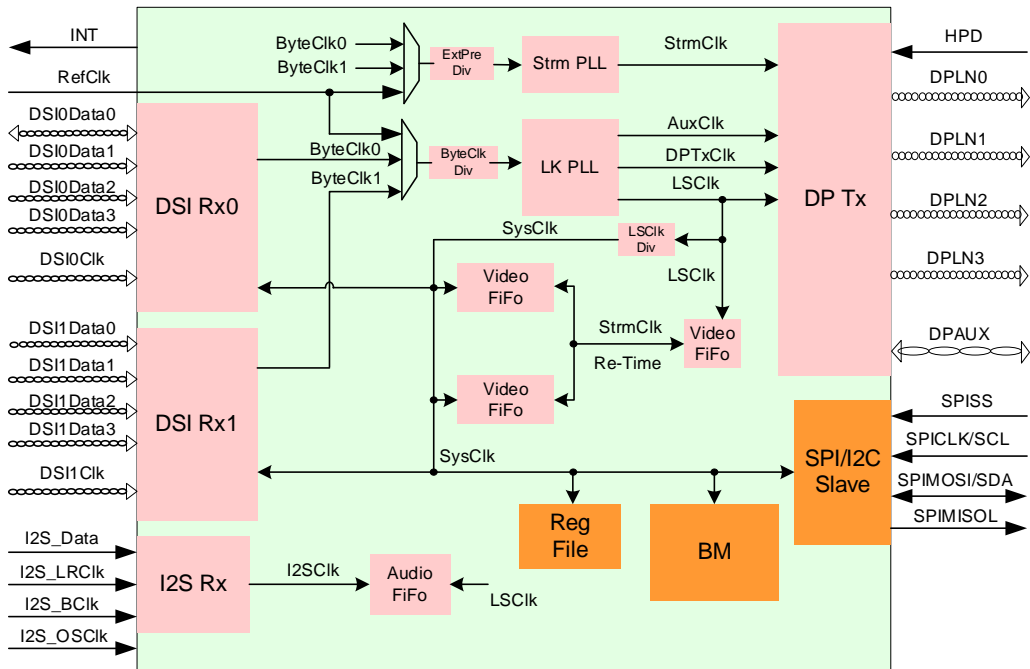

Figure 1.2 TC358770AXBG / TC358777XBG Block Diagram and Functional

2. Features

- TC358770AXBG / TC358777XBG follows the following standards:
 - ✧ MIPI DSI version 1.02, Jan 2010.
 - ✧ MIPI D-PHY version 1.0, May 2009.
 - ✧ VESA® DisplayPort™ Standard version 1.1a, Jan. 11 2008.
- DSI Receiver
 - ✧ Dual 4-Data Lane DSI Link with Bi-direction support at Data Lane 0, it can be used in 1-, 2-, 3- or 4-data lane configuration.
 - ✧ Maximum speed at 1 Gbps/lane.
 - ✧ Video input data formats: RGB-565, RGB-666 and RGB-888.
 - ✧ New DSI V1.02 Data Type, 16-bit YCbCr 422, is supported.
 - ✧ Interlaced video mode is not supported.
 - ✧ Provide path for DSI host/transmitter to control TC358770AXBG / TC358777XBG and its attached panel.
 - ✧ DSI Link High Speed clock, DSIClk or an external clock, RefClk, is required before programming TC358770AXBG.
- DisplayPort™ Source/Transmitter
 - ✧ VESA® DisplayPort™ Rev 1.1a Standard.
 - Bit Rate @ 1.62 or 2.7 Gbps, Voltage Swing @0.4, 0.6, 0.8 or 1.2 V, Pre-Emphasis Level @0, 3.5 or 6 dB.
 - There are four lanes available in DP main Link, which can operate in 1-, 2- or 4-lane configuration.
 - AUX channel with nominal bit rate at 1 Mbps.
 - ✧ After receiving DSI link burst data, TC358770AXBG / TC358777XBG retimes video data to DP panel's pixel clock for Synchronous (to DisplayPort™ link symbol clock, LSClk) Clock Mode operation.
 - ✧ SSCG with up to 30 kHz modulation to reduce EMI.
 - ✧ Built in PRBS7 Generator to test DisplayPort™ Link without DSI input.
 - ✧ Built in Color Bar Generator to verify DisplayPort™ protocol.
 - ✧ Not support HDCP.
 - ✧ Secure ASSR (Alternate Scrambler Seed Reset) support for eDP panels
 - System designer connects ASSR_DisablePad to an inner ring VSS_IO pad, e.g. pad E4, to enable eDP panels and ASSR
 - Drive ASSR_DisablePad with an inner ring VDDSD pad, e.g. pad D5, for using DP panels and disable ASSR
 - System software read Revision ID field, 0x0500[7:0]:
 - 0x01 indicates eDP panels are used, DPCD register bit 0x0010A[0] of eDP panel should be set
 - 0x03 assumes DP panels are connected, DPCD register bit 0x0010A[0] of DP panel should Not be set
- I²C Slave Port
 - ✧ Support for normal (100 kHz) and fast (400 kHz) modes.
 - ✧ External I²C master can access TC358770AXBG / TC358777XBG internal registers via this port.
 - ✧ Address auto increment is supported.
 - ✧ TC358770AXBG / TC358777XBG Slave Port address is 0x68, (binary 1101_000x) where x = 1 for read and x = 0 for write. The slave address can be changed to 0x0F (binary 0001_111x) by tying pin SPI_SS/I2C_ADR_SEL to high.

- SPI Slave Interface
 - ✧ Slave select pin supported.
 - ✧ Clock Polarity and Phase as per SPI MODE0 (polarity = 0, phase = 0).
 - ✧ Transfer Frame size of 48 bits.
 - ✧ Maximum clock speed is up to 30 MHz.

- Audio Interface
 - ✧ Support either I2S or TDM (Time Division Multiplex) mode.
 - ✧ TDM mode can support 2, 4, 6 and 8 channel of audio data.
 - ✧ Support 16, 18, 20 or 24-bit PCM audio data word.
 - ✧ Sample frequency, f_s , supported: 32, 44.1, 48, 88.2, 96, 176.4 & 192 kHz.
 - ✧ $512 * f_s$ audio oversample clock is required to generate accurate audio clock timestamps in order for the DisplayPort™ panel to recover audio clock correctly.
 - ✧ Ability to insert IEC60958 status bits and preamble bits per channel.

- Operation
 - ✧ Host programs TC358770AXBG / TC358777XBG either by using DSI link 0 (DSI0), I²C bus or SPI bus.
 - ✧ TC358770AXBG / TC358777XBG provides "mailbox registers," 20-bit AuxAddr and 16-byte AuxData, for Host to access DisplayPort™ Panel's DisplayPort™ Configuration Data, DPCD, registers.
 - ✧ Host splits a video line data into two streams of DSI video packets. Host has two options to split the video line data:
 - Left-Right Side: Left (first) side video packet goes to DSI0 and Right side data to DSI1.
 - Even-Odd Group: Even (first) groups of pixels are transmitted in DSI0 while Odd ones are carried by DSI1.
 - The number of pixels per group is programmable; from 1 to 64.
 - The number of pixels per group and/or the number of groups in each video packet can be different between the two DSI links. This feature in connection with TC358770AXBG's capability to support configurable number of data lanes.
 - It is recommended that host pack the split video line data into one video packet for each DSI link before transmitting. However, TC358770AXBG / TC358777XBG supports multiple DSI packets per horizontal line time as long as DSI link bandwidth is enough for the overhead.
 - ✧ TC358770AXBG / TC358777XBG is responsible to generate video frame timing based on the register values set by the Host. Host does not have to care/generate video horizontal timings, such as Horizontal Front/Back Porch and Horizontal Pulse width. Host is responsible to send the video data packets to TC358770AXBG / TC358777XBG in time line-by-line and separated each line data by HSS.
 - Host is expected to send exactly one line of video data per horizontal sync period between the two DSI links.
 - Host is expected to start HSS₀, HSS packet of DSI0, and HSS₁, HSS packet of DSI1, either at "the same time" or with fixed delay/skew between them (HSS₀ earlier than that of HSS₁).
 - "The same time" means within +/- 5 clock cycles.
 - The time skew between the two DSI links' Hsync Start, HSS, packet cannot drift more than one video line time within one video frame period.
 - Host is recommended to use the same clock source to generate both DSI link clocks in order to prevent these two clocks from drifting away.
 - Otherwise, clock sources with 50 ppm accuracy are required.
 - It is recommended that each DSI link sends HSS and video packets back-to-back. Host can insert variable length of blanking packet between HSS and video packets as long as the bandwidth is allowed.
 - ✧ TC358770AXBG / TC358777XBG concatenates two (streams of) video packets, one (stream) from each DSI link, into a single DisplayPort™ video stream before transmitting it out to the panel.

- Clock Source:
 - ✧ An external reference clock, RefClk, is used to drive PLLs for generating DisplayPort's stream/pixel clock, StrmClk/PixelClk, and Link Symbol Clock, LSClk.
 - Support DisplayPort™ Synchronous (StrmClk and LSClk) Clock Mode.
 - Allowed RefClk Frequency Value: 13, 19.2, 26, 38.4 MHz.
 - ✧ Optionally, DSI DSIClk can be used/divided down to replace RefClk and drive PLLs used to generate the required clocks.
 - The divisor, from DSI ByteClk, can be either
 - 3 (115.2/3 = 38.4)
 - 4 (104/4 = 26)
 - 5 (96/5 = 19.2)
 - 9 (117/9 = 13)

- Power Supply
 - ✧ MIPI D-PHY and DP PHY: 1.2 V
 - ✧ Core: 1.2 V
 - ✧ DP-PHY: 1.8 V
 - ✧ I/O: 1.8 V to 3.3 V (all IO pins must be same power level)
 - ✧ HPD Input Pad: 3.3 V

- Power Consumption (Typical Condition)
 - ✧ Sleep State, with RESX asserted
 - 12 mW
 - ✧ Typical Operation:
 - 2560 × 1440 × 24@60fps
 - Dual DSIRx, each link @3.7 Gbps
 - 31 mW for both Links
 - Core
 - 165 mW
 - DP Tx (2.7 Gbps Link speed @4 lanes, 0.4 V Swing without Pre-Emphasis)
 - 168.5 mW
 - Total = 364.5 mW
 - The breakdown of each power rail is shown in the table below

	VDD_DSI (1.2 V)	VDDC (1.2 V)	PLL9 (1.2 V)	DP_12 (1.2 V)	DP_18 (1.8 V)	DPA_18 (1.8 V)	VDDS (1.8 V)	Total Power	Unit
Typical Operation	25.84	153.23	2.27	50.87	56.99	2.69	0		mA
	31.01	162.28	2.73	61.05	102.58	4.84	0	364.5	mW
Power Down	0.1	3.8	0	2.1	0	2.7	0		mA
	0.12	4.56	0	2.52	0	4.86	0	12	mW

- Packaging
 - ✧ 10 × 10 BGA with 0.4 mm ball pitch
 - ✧ 5 × 5 mm²

Note: Attention about ESD. This product is weak against ESD. Please handle it carefully.

3. External Pins

3.1. TC358770AXBG Pin Layout

The mapping of TC358770AXBG signals to the external pins is shown in the figure below.

A1 DSI0DM_0	A2 DSI0DP_0	A3 DSI1DM_3	A4 DSI1DM_2	A5 DSI1CM	A6 VDD_DSI12	A7 VSS_DSI	A8 DSI1DM_1	A9 DSI1DM_0	A10 TEST
B1 DSI0DM_1	B2 DSI0DP_1	B3 DSI1DP_3	B4 DSI1DP_2	B5 DSI1CP	B6 VSS_DSI	B7 VDD_DSI12	B8 DSI1DP_1	B9 DSI1DP_0	B10 VDDDS
C1 VSS_DSI	C2 VDD_DSI12	C3 DIG_4	C4 DIG_3	C5 DIG_2	C6 DIG_1	C7 VSS_IO	C8 DIG_0	C9 RESX	C10 SPI_SCLK/ I2C_SCL
D1 DSI0CM	D2 DSI0CP	D3 VDDC	D4 VSSC	D5 VDDDS	D6 SPI_SS	D7 SPI_MOSI/ I2C_SDA	D8 VPGM_1	D9 SPI_MISO	D10 I2S_OSCLK
E1 VDD_DSI12	E2 VSS_DSI	E3 SPI_I2C	E4 VSS_IO	E5 Disable_ ASSR	E6 DIG_5	E7 INT	E8 I2S_LRCLK	E9 I2S_BCLK	E10 I2S_DATA
F1 DSI0DM_2	F2 DSI0DP_2	F3 TM_CNT	F4 DIG_7	F5 DIG_8	F6 VSSC	F7 VDDC	F8 VPGM_0	F9 VSS_PLL9	F10 VDD_PLL912
G1 DSI0DM_3	G2 DSI0DP_3	G3 PREC_RES_0	G4 PREC_RES_1	G5 VSS_DP	G6 DIFF_SE	G7 HPD	G8 VSS_DP	G9 DPAUXP	G10 DPAUXM
H1 ATB_1	H2 VDD_PLL18	H3 VDD_PLL12	H4 VSS_PLL	H5 VDD_DP12	H6 VSS_DP	H7 VDD_DP12	H8 VDD_DP18	H9 VSS_DPA	H10 VDD_DPA18
J1 REFCLK	J2 VDD_DP12	J3 DPLNP_0	J4 VSS_DP	J5 DPLNP_1	J6 VDD_DP12	J7 DPLNP_2	J8 VSS_DP	J9 DPLNP_3	J10 VDD_DP18
K1 ATB_0	K2 VSS_DP	K3 DPLNM_0	K4 VDD_DP18	K5 DPLNM_1	K6 VSS_DP	K7 DPLNM_2	K8 VDD_DP18	K9 DPLNM_3	K10 VSS_DP

Figure 3.1 TC358770AXBG Chip Pin Layout (Top view)

3.2. TC358777XBG Pin Layout

The mapping of TC358777XBG signals to the external pins is shown in the figure below.

A1 DSI0DM_0	A2 DSI0DP_0	A3 VDD_DSI12	A4 DSI1DM_3	A5 DSI1DM_2	A6 DSI1CM	A7 VDD_DSI12	A8 DSI1DM_1	A9 DSI1DM_0	A10 VDDIO
B1 DSI0DM_1	B2 DSI0DP_1	B3 VSS	B4 DSI1DP_3	B5 DSI1DP_2	B6 DSI1CP	B7 VSS	B8 DSI1DP_1	B9 DSI1DP_0	B10 RESX
C1 DSI0CM	C2 DSI0CP							C9 SPI_SCLK	C10 SPI_MISO
D1 DSI0DM_2	D2 DSI0DP_2		D4 TEST5	D5 TEST6	D6 TEST7	D7 TEST		D9 SPI_SS	D10 SPI_MOSI
E1 DSI0DM_3	E2 DSI0DP_3		E4 VSS	E5 TEST3	E6 TEST4	E7 VPGM		E9 INT	E10 I2S_OSCLK
F1 VDDC	F2 VSS		F4 TEST9	F5 VSS	F6 TEST8	F7 Disable ASSR		F9 I2S_BCLK	F10 I2S_DATA
G1 PREC_RES_0	G2 PREC_RES_1		G4 DIFF_SE	G5 TEST2	G6 TEST10	G7 VSS		G9 SPI_I2C	G10 I2S_LRCLK
H1 VDDC	H2 VSS							H9 HPD	H10 VDD_PLL912
J1 VDD_DP12	J2 VSS_DP	J3 DPLNP_0	J4 VSS_DP	J5 DPLNP_1	J6 VSS_DP	J7 DPLNP_2	J8 VSS_DP	J9 DPLNP_3	J10 DPAUXP
K1 VDD_PLL18	K2 REFCLK	K3 DPLNM_0	K4 VDD_DP18	K5 DPLNM_1	K6 VDD_DP12	K7 DPLNM_2	K8 VDD_DP18	K9 DPLNM_3	K10 DPAUXM

Figure 3.2 TC358777XBG Chip Pin Layout (Top view)

3.3. TC358770AXBG Pinout Description

The following table gives the signals of TC358770AXBG and their function.

Table 3.1 TC358770AXBG Functional Signal List

Group	Pin Name	I/O	Type	Function	Power Supply
System (6)	REFCLK	I	SCH	13, 19.2, 26 or 38.4 MHz Ref Clock	1.8 V
	DIFF_SE	I	Normal	1: Differential RefClk is used 0: Singled end RefClk is used	1.8 – 3.3 V
	SPI_I2C	I	Normal	1: Activate SPI Slave Interface 0: Select I ² C Slave Port	1.8 – 3.3 V
	RESX	I	SCH	System Reset – active Low	1.8 – 3.3 V
	DISABLE_ASSR	I	Normal	1: Disable ASSR, set when connecting to DP panel 0: Enable ASSR for eDP panel application	1.8 – 3.3 V
	INT	O	Normal	Interrupt Pin to Host	1.8 – 3.3 V
DSI0Rx (10)	DSI0CP	I	MIPI-PHY	MIPI-DSI0 Rx Clock Lane Positive	1.2 V
	DSI0CM	I	MIPI-PHY	MIPI-DSI0 Rx Clock Lane Negative	1.2 V
	DSI0DP[0]	I/O	MIPI-PHY	MIPI-DSI0 Rx Data Lane Positive	1.2 V
	DSI0DM[0]	I/O	MIPI-PHY	MIPI-DSI0 Rx Data Lane Negative	1.2 V
	DSI0DP[3:1]	I	MIPI-PHY	MIPI-DSI0 Rx Data Lane Positive	1.2 V
	DSI0DM[3:1]	I	MIPI-PHY	MIPI-DSI0 Rx Data Lane Negative	1.2 V
DSI1Rx (10)	DSI1CP	I	MIPI-PHY	MIPI-DSI1 Rx Clock Lane Positive	1.2 V
	DSI1CM	I	MIPI-PHY	MIPI-DSI1 Rx Clock Lane Negative	1.2 V
	DSI1DP[3:0]	I	MIPI-PHY	MIPI-DSI1 Rx Data Lane Positive	1.2 V
	DSI1DM[3:0]	I	MIPI-PHY	MIPI-DSI1 Rx Data Lane Negative	1.2 V
DPTx (15)	HPD	I/O	OD	DP Rx Interrupt/Detected	1.8 – 3.3 V
	DPLNP[3:0]	O	DP-PHY	DP Output Main Link Positive	1.8 – 3.3 V
	DPLNM[3:0]	O	DP-PHY	DP Output Main Link Negative	1.8 – 3.3 V
	DPAUXP	I/O	DP-PHY	DP Output AUX Channel Positive	1.8 – 3.3 V
	DPAUXM	I/O	DP-PHY	DP Output AUX Channel Positive	1.8 – 3.3 V
	ATB[0]	I/O	DP-PHY	Analog Test Bus Output REFCLKN input when DIFF_SE is asserted	1.8 – 3.3 V
	ATB[1]	O	DP-PHY	Analog Test Bus Output	1.8 – 3.3 V
	PREC_RES[1:0]	I	DP-PHY	Precision Resistance (3K @1%)	1.8 – 3.3 V
Audio (4)	I2S_OSCLK	I	Normal	512 times Audio Sample Clock	1.8 – 3.3 V
	I2S_BCLK	I	Normal	Audio Clock	1.8 – 3.3 V
	I2S_LRCLK	I	Normal	Audio Left/Right Selector	1.8 – 3.3 V
	I2S_DATA	I	Normal	Audio Data	1.8 – 3.3 V
SPI/I2C (4)	SPI_SCLK / I2C_SCL	I	OD	SPI Clock / I ² C Clock	1.8 – 3.3 V
	SPI_MOSI / I2C_SDA	I/O	OD	SPI Input data / I ² C SDA	1.8 – 3.3 V
	SPI_MISO	O	N	SPI Output data to Host	1.8 – 3.3 V
	SPI_SS_I2C_ADR_SEL	I	N	SPI Slave Select, I ² C Slave Address Select	1.8 – 3.3 V
DFT (10)	TEST	I	N	Test Pin, active high	1.8 – 3.3 V
	TM_CNT	I	N	Test Pin, please tie to GND	1.8 – 3.3 V
	DIG[8:7], DIG[5:0]	I/O	N	Test Pin, please tie to GND	1.8 – 3.3 V
Power (22)	VDDS(2)	—	—	VDD for IO power supply	1.8 – 3.3 V
	VDD_DP18 (4)	—	—	VDD for DP PHY	1.8 V
	VDD_DPA18 (1)	—	—	VDD for DP Analog PHY	1.8 V
	VDD_PLL18 (1)	—	—	VDD for DP PLL	1.8 V
	VDD_PLL12 (1)	—	—	VDD for DP PLL	1.2 V
	VDD_DP12 (4)	—	—	VDD for DP PHY	1.2 V
	VDD_PLL912 (1)	—	—	VDD for Stream Clock PLL	1.2 V
	VDD_DSI12 (4)	—	—	VDD for MIPI-DSI PHY	1.2 V
	VDDC (2)	—	—	VDD for Internal Core	1.2 V
	VPGM (2)	—	—	eFuse Programming Voltage	1.8 – 3.3 V
Ground (19)	VSS_IO (2)	—	—	VSS for IO power supply	—
	VSS_DP (8)	—	—	VSS for DP PHY	—
	VSS_DPA (1)	—	—	VSS for DP PHY	—
	VSS_PLL (1)	—	—	VSS for DP PLL	—
	VSS_PLL9 (1)	—	—	VSS for Stream Clock PLL	—
	VSS_DSI12 (4)	—	—	VSS for MIPI-DSI PHY	—
	VSSC (2)	—	—	VSS for Internal Core	—

Normal: Normal IO (4 mA)
OD: Pseudo open-drain output, schmitt input
FS/SCH: Fail Safe schmitt input buffer
MIPI-PHY: Front-end analog IO for MIPI
DP-PHY: Front-end analog IO for DisplayPort™

Table 3.2 Pin Count Summary

Group Name	Pin Count
SYSTEM	6
DSI Rx	20
DisplayPort™ Tx	15
Audio	4
SPI/I2C	4
Test	10
POWER	22
GROUND	19
Total	100

3.4. TC358777XBG Pinout Description

The following table gives the signals of TC358777XBG and their function.

Table 3.3 TC358777XBG Functional Signal List

Group	Pin Name	I/O	Type	Function	Power Supply
System (6)	REFCLK	I	SCH	13, 19.2, 26 or 38.4 MHz Ref Clock	1.8 V
	DIFF_SE	I	Normal	1: Differential RefClk is used 0: Singled end RefClk is used	1.8 – 3.3 V
	SPI_I2C	I	Normal	1: Activate SPI Slave Interface 0: Select I ² C Slave Port	1.8 – 3.3 V
	DISABLE_ASSR	I	Normal	1: Disable ASSR, set when connecting to DP panel 0: Enable ASSR for eDP panel application	1.8 – 3.3 V
	RESX	I	SCH	System Reset – active Low	1.8 – 3.3 V
	INT	O	Normal	Interrupt Pin to Host	1.8 – 3.3 V
DSI0Rx (10)	DSI0CP	I	MIPI-PHY	MIPI-DSI0 Rx Clock Lane Positive	1.2 V
	DSI0CM	I	MIPI-PHY	MIPI-DSI0 Rx Clock Lane Negative	1.2 V
	DSI0DP[0]	I/O	MIPI-PHY	MIPI-DSI0 Rx Data Lane Positive	1.2 V
	DSI0DM[0]	I/O	MIPI-PHY	MIPI-DSI0 Rx Data Lane Negative	1.2 V
	DSI0DP[3:1]	I	MIPI-PHY	MIPI-DSI0 Rx Data Lane Positive	1.2 V
	DSI0DM[3:1]	I	MIPI-PHY	MIPI-DSI0 Rx Data Lane Negative	1.2 V
DSI1Rx (10)	DSI1CP	I	MIPI-PHY	MIPI-DSI1 Rx Clock Lane Positive	1.2 V
	DSI1CM	I	MIPI-PHY	MIPI-DSI1 Rx Clock Lane Negative	1.2 V
	DSI1DP[3:0]	I	MIPI-PHY	MIPI-DSI1 Rx Data Lane Positive	1.2 V
	DSI1DM[3:0]	I	MIPI-PHY	MIPI-DSI1 Rx Data Lane Negative	1.2 V
DPTx (13)	HPD	I/O	OD	DP Rx Interrupt/Detected	1.8 – 3.3 V
	DPLNP[3:0]	O	DP-PHY	DP Output Main Link Positive	1.8 – 3.3 V
	DPLNM[3:0]	O	DP-PHY	DP Output Main Link Negative	1.8 – 3.3 V
	DPAUXP	I/O	DP-PHY	DP Output AUX Channel Positive	1.8 – 3.3 V
	DPAUXM	I/O	DP-PHY	DP Output AUX Channel Positive	1.8 – 3.3 V
	PREC_RES[1:0]	I	DP-PHY	Precision Resistance (3K @1%)	1.8 – 3.3 V
Audio (4)	I2S_OCLK	I	Normal	512 times Audio Sample Clock	1.8 – 3.3 V
	I2S_BCLK	I	Normal	Audio Clock	1.8 – 3.3 V
	I2S_LRCLK	I	Normal	Audio Left/Right Selector	1.8 – 3.3 V
	I2S_DATA	I	Normal	Audio Data	1.8 – 3.3 V
SPI/I2C (4)	SPI_SCLK / I2C_SCL	I	OD	SPI Clock / I ² C Clock	1.8 – 3.3 V
	SPI_MOSI / I2C_SDA	I/O	OD	SPI Input data / I ² C SDA	1.8 – 3.3 V
	SPI_MISO	O	N	SPI Output data to Host	1.8 – 3.3 V
	SPI_SS I2C_ADR_SEL	I	N	SPI Slave Select, I ² C Slave Address Select	1.8 – 3.3 V
DFT (10)	TEST	I	N	Test Pin, active high	1.8 – 3.3 V
	TEST[10:2]	I	N	Test Pin, please tie to GND	—
Power (12)	VDD_IO (1)	—	—	VDD for IO power supply	1.8 – 3.3 V
	VDD_DP18 (2)	—	—	VDD for DP PHY/Analog PHY	1.8 V
	VDD_PLL18 (1)	—	—	VDD for DP PLL	1.8 V
	VDD_DP12 (2)	—	—	VDD for DP PHY/PLL	1.2 V
	VDD_PLL912 (1)	—	—	VDD for Stream Clock PLL	1.2 V
	VDD_DSI12 (2)	—	—	VDD for MIPI-DSI PHY	1.2 V
	VDDC (2)	—	—	VDD for Internal Core	1.2 V
	VPGM (1)	—	—	eFuse Programming Voltage	1.8 – 3.3 V
Ground (11)	VSS_DP (4)	—	—	VSS for DP PHY/PLL	—
	VSS (7)	—	—	VSS for Internal Core/MIPI/IO	—

- Normal: Normal IO (4 mA)
- OD: Pseudo open-drain output, Schmitt input
- FS/SCH: Fail Safe Schmitt input buffer
- MIPI-PHY: Front-end analog IO for MIPI
- DP-PHY: Front-end analog IO for DisplayPort™

Table 3.4 Pin Count Summary

Group Name	Pin Count
SYSTEM	6
DSI Rx	20
DisplayPort™ Tx	13
I2S	4
SPI/I2C	4
Test	10
POWER	12
GROUND	11
Total	80

4. Package

TC358770AXBG housed in a 5.0 mm by 5.0 mm size package with 0.4 mm ball pitch. The detailed package drawing is shown below.

P-VFBGA100-0505-0.40-001

"Unit:mm"

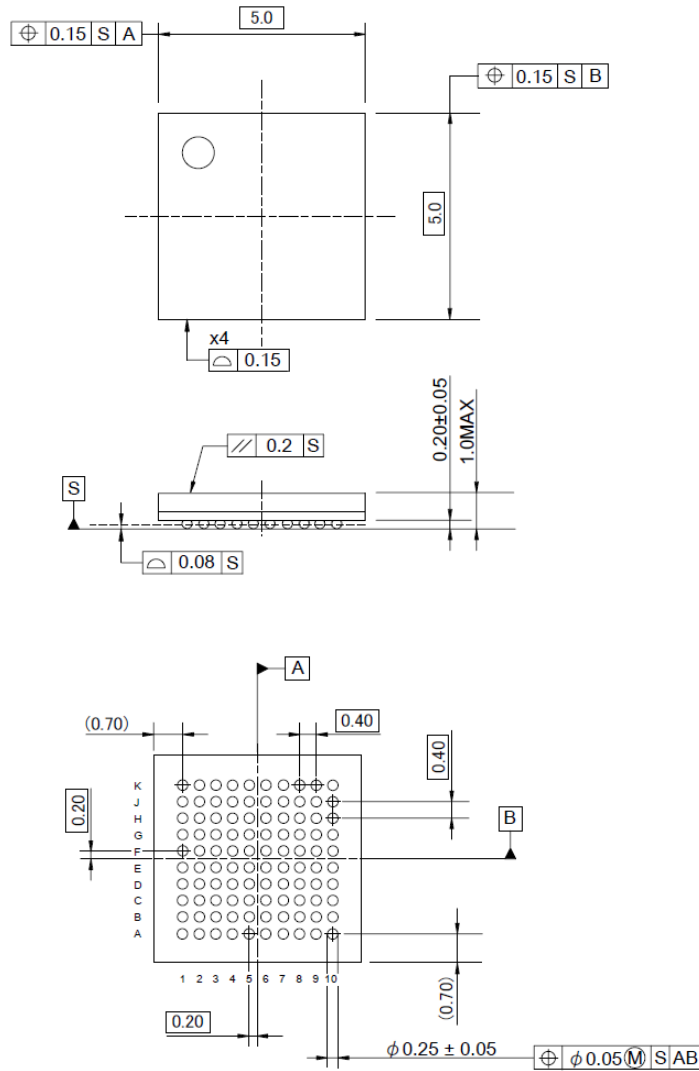

Weight: 40 mg (Typ.)

Figure 4.1 TC358770AXBG Package Dimension

Table 4.1 TC358770AXBG Package Details

Description	Normal
Body size (W, mm)	5
Body size (L, mm)	5
Overall thickness (t, mm)	1
Terminal pitch (mm)	0.4

TC358777XBG housed in a 7.0 mm by 7.0 mm size package with 0.65 mm ball pitch. The detailed package drawing is shown below.

P-VFBGA80-0707-0.65-001

"Unit:mm"

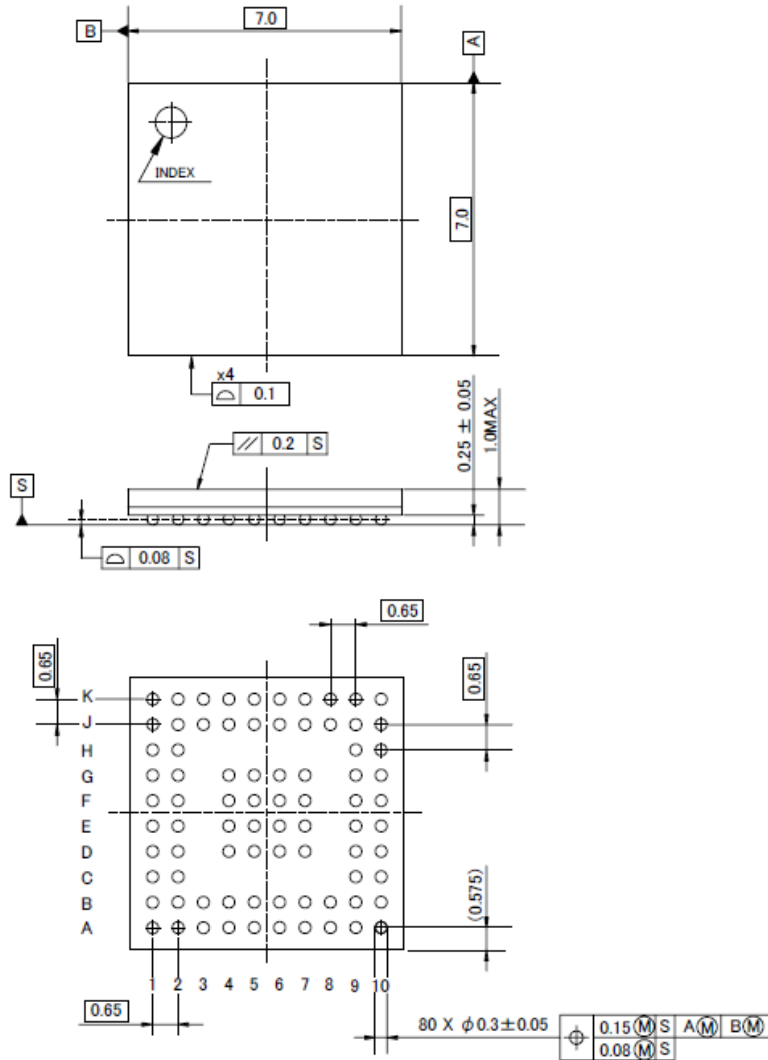

Weight: 66 mg (Typ.)

Figure 4.2 TC358777XBG Package Dimension

Table 4.2 TC358777XBG Package Details

Description	Normal
Body size (W, mm)	7
Body size (L, mm)	7
Overall thickness (t, mm)	1
Terminal pitch (mm)	0.65

5. Electrical characteristics

5.1. Absolute Maximum Ratings

VSS = 0 V reference

VDD18 used for VDDIO as well as VDD_DP18; VDD12 used for VDDC as well as VDD_DSI12

Parameter	Symbol	Rating	Unit
Supply voltage (1.8 V)	VDD18	-0.3 to +3.5	V
Supply voltage (1.2 V)	VDD12	-0.3 to +2.0	V
Supply voltage (IO)	VDD18	-0.3 to +3.5	V
	V _{REF}	-0.3 to +3.5	V
Input voltage	V _{IN}	-0.3 to VDDIO+0.3	V
Output voltage	V _{OUT}	-0.3 to VDDIO+0.3	V
Storage temperature	T _{stg}	-40 to +125	°C

5.2. Operating Condition

VSS = 0 V reference

VDD18 used for VDDIO as well as VDD_DP18; VDD12 used for VDDC as well as VDD_DSI12

Parameter	Symbol	Min	Typ.	Max	Unit
Supply voltage (1.8 V)	VDD18	1.71	1.8	1.89	V
Supply voltage (1.2 V)	VDD12	1.14	1.2	1.26	V
Operating frequency (internal)	F _{op}	—	—	270	MHz
Operating temperature	T _a	-20	—	+70	°C

5.3. DC Electrical Specification

VSS = VSSC = VSS_IO = VSS_DSI12 = VSS_DP = VSS_DPA = VSS_PLL = VSS_PLL9 = 0 V reference

Parameter	Symbol	Min	Typ.	Max	Unit
Input voltage High level CMOS input (Note1)	V _{IH}	0.7 VDDIO	—	VDDIO	V
Input voltage Low level CMOS input (Note1)	V _{IL}	0	—	0.3 VDDIO	V
Input voltage High level CMOS Schmitt Trigger (Note1)	V _{IHS}	0.7 VDDIO	—	VDDIO	V
Input voltage Low level CMOS Schmitt Trigger (Note1)	V _{ILS}	0	—	0.3 VDDIO	V
Output voltage High level (Note1) (Note2)	V _{OH}	0.8 VDDIO	—	VDDIO	V
Output voltage Low level (Note1) (Note2)	V _{OL}	0	—	0.2 VDDIO	V
Input leak current High level	I _{IH1} (Note3)	-10	—	10	μA
Input leak current Low level	I _{IL1} (Note4)	-10	—	10	μA
	I _{IL2} (Note5)	-200	—	-10	μA

Note1: VDDIO within operating condition.

Note2: Output current value is according to each IO buffer specification. Output voltage changes with output current value.

Note3: Normal pin, or Pull-up I/O pin applied VDD18_IO supply voltage to input pin.

Note4: Normal pin applied VSS (0 V) to input pin.

Note5: Pull-up I/O pin applied VSS (0 V) to input pin.

6. Revision History

Table 6.1 Revision History

Revision	Date	Description
1.0	2012-11-10	<ol style="list-style-type: none"> 1. Start from 770XBG Rev 0.99D 2. Add ASSR support 3. Add Power consumption for each voltage rail
1.1	2013-01-15	<ol style="list-style-type: none"> 1. Update MIPI copyright Footer: Change "Toshiba America Electronic Components, Inc." to "Toshiba Corporation and its affiliates." 2. Update VSDelay Calculation (assume DP data lane is either 2 or 4 lanes)
1.2	2013-10-25	<ol style="list-style-type: none"> 1. Typo correction on register Tx_Rx_TA 2. Add Audio Functionality Description
1.3	2013-11-17	<ol style="list-style-type: none"> 1. Update register field description for 0x0644[23:18]
1.4	2014-06-20	<ol style="list-style-type: none"> 1. Add 777XBG package
1.41	2016-07-20	<ol style="list-style-type: none"> 1. Typo Correction on DSI1DP[3:0]/DSI1DM[3:0]
1.42	2016-09-01	<ol style="list-style-type: none"> 1. Modified duplicate DSI1CP/DSI1CM.
1.6	2017-10-23	<p>Corrected typo. Changed header, footer and the last page. Changed corporate name.</p>
1.63	2019-02-07	<p>Modified descriptions of trademark and service mark. Corrected typos. Modified descriptions of I²C in Features. Corrected weight of TC358777XBG in cover page and chapter 4. Revised the last page "RESTRICTIONS ON PRODUCT USE" and added URL.</p>
1.65	2024-04-10	<p>Changed from supporting HDCP to not supporting HDCP. Corrected typos.</p>

RESTRICTIONS ON PRODUCT USE

Toshiba Corporation and its subsidiaries and affiliates are collectively referred to as "TOSHIBA". Hardware, software and systems described in this document are collectively referred to as "Product".

- TOSHIBA reserves the right to make changes to the information in this document and related Product without notice.
- This document and any information herein may not be reproduced without prior written permission from TOSHIBA. Even with TOSHIBA's written permission, reproduction is permissible only if reproduction is without alteration/omission.
- Though TOSHIBA works continually to improve Product's quality and reliability, Product can malfunction or fail. Customers are responsible for complying with safety standards and for providing adequate designs and safeguards for their hardware, software and systems which minimize risk and avoid situations in which a malfunction or failure of Product could cause loss of human life, bodily injury or damage to property, including data loss or corruption. Before customers use the Product, create designs including the Product, or incorporate the Product into their own applications, customers must also refer to and comply with (a) the latest versions of all relevant TOSHIBA information, including without limitation, this document, the specifications, the data sheets and application notes for Product and the precautions and conditions set forth in the "TOSHIBA Semiconductor Reliability Handbook" and (b) the instructions for the application with which the Product will be used with or for. Customers are solely responsible for all aspects of their own product design or applications, including but not limited to (a) determining the appropriateness of the use of this Product in such design or applications; (b) evaluating and determining the applicability of any information contained in this document, or in charts, diagrams, programs, algorithms, sample application circuits, or any other referenced documents; and (c) validating all operating parameters for such designs and applications. **TOSHIBA ASSUMES NO LIABILITY FOR CUSTOMERS' PRODUCT DESIGN OR APPLICATIONS.**
- **PRODUCT IS NEITHER INTENDED NOR WARRANTED FOR USE IN EQUIPMENTS OR SYSTEMS THAT REQUIRE EXTRAORDINARILY HIGH LEVELS OF QUALITY AND/OR RELIABILITY, AND/OR A MALFUNCTION OR FAILURE OF WHICH MAY CAUSE LOSS OF HUMAN LIFE, BODILY INJURY, SERIOUS PROPERTY DAMAGE AND/OR SERIOUS PUBLIC IMPACT ("UNINTENDED USE").** Except for specific applications as expressly stated in this document, Unintended Use includes, without limitation, equipment used in nuclear facilities, equipment used in the aerospace industry, lifesaving and/or life supporting medical equipment, equipment used for automobiles, trains, ships and other transportation, traffic signaling equipment, equipment used to control combustions or explosions, safety devices, elevators and escalators, and devices related to power plant. **IF YOU USE PRODUCT FOR UNINTENDED USE, TOSHIBA ASSUMES NO LIABILITY FOR PRODUCT.** For details, please contact your TOSHIBA sales representative or contact us via our website.
- Do not disassemble, analyze, reverse-engineer, alter, modify, translate or copy Product, whether in whole or in part.
- Product shall not be used for or incorporated into any products or systems whose manufacture, use, or sale is prohibited under any applicable laws or regulations.
- The information contained herein is presented only as guidance for Product use. No responsibility is assumed by TOSHIBA for any infringement of patents or any other intellectual property rights of third parties that may result from the use of Product. No license to any intellectual property right is granted by this document, whether express or implied, by estoppel or otherwise.
- **ABSENT A WRITTEN SIGNED AGREEMENT, EXCEPT AS PROVIDED IN THE RELEVANT TERMS AND CONDITIONS OF SALE FOR PRODUCT, AND TO THE MAXIMUM EXTENT ALLOWABLE BY LAW, TOSHIBA (1) ASSUMES NO LIABILITY WHATSOEVER, INCLUDING WITHOUT LIMITATION, INDIRECT, CONSEQUENTIAL, SPECIAL, OR INCIDENTAL DAMAGES OR LOSS, INCLUDING WITHOUT LIMITATION, LOSS OF PROFITS, LOSS OF OPPORTUNITIES, BUSINESS INTERRUPTION AND LOSS OF DATA, AND (2) DISCLAIMS ANY AND ALL EXPRESS OR IMPLIED WARRANTIES AND CONDITIONS RELATED TO SALE, USE OF PRODUCT, OR INFORMATION, INCLUDING WARRANTIES OR CONDITIONS OF MERCHANTABILITY, FITNESS FOR A PARTICULAR PURPOSE, ACCURACY OF INFORMATION, OR NONINFRINGEMENT.**
- Do not use or otherwise make available Product or related software or technology for any military purposes, including without limitation, for the design, development, use, stockpiling or manufacturing of nuclear, chemical, or biological weapons or missile technology products (mass destruction weapons). Product and related software and technology may be controlled under the applicable export laws and regulations including, without limitation, the Japanese Foreign Exchange and Foreign Trade Law and the U.S. Export Administration Regulations. Export and re-export of Product or related software or technology are strictly prohibited except in compliance with all applicable export laws and regulations.
- Please contact your TOSHIBA sales representative for details as to environmental matters such as the RoHS compatibility of Product. Please use Product in compliance with all applicable laws and regulations that regulate the inclusion or use of controlled substances, including without limitation, the EU RoHS Directive. **TOSHIBA ASSUMES NO LIABILITY FOR DAMAGES OR LOSSES OCCURRING AS A RESULT OF NONCOMPLIANCE WITH APPLICABLE LAWS AND REGULATIONS.**

Toshiba Electronic Devices & Storage Corporation

<https://toshiba.semicon-storage.com/>