

74AVCH4T245FT

1. Functional Description

- 2-Bit×2 Dual-Supply Bus Transceiver with Bushold and Configurable Power Supply

2. General

The 74AVCH4T245FT is a dual-supply, high-speed CMOS 2-bit × 2-circuit bus transceiver with bus hold circuitry that allows interfacing between two systems with supply voltages from 0.7 V to 3.6 V.

The two supply voltages can be user-configurable within the operating range and the sequence of supply voltage ON/OFF can be freely set.

The bus hold function holds the voltage at the bus terminal input. When the enable input \overline{OE} is set to "H", the internal buffer is in a high impedance mode and the bus pins (nA, nB) are in bus hold mode. When the transmission direction switching input DIR is set to "H", bus A becomes an input and bus B becomes an output, and when set to "L", bus A becomes an output and bus B becomes an input. The input (DIR and \overline{OE}) has a tolerant function that allows input of up to 3.6 V regardless of the supply voltage. By setting one or both power supplies to GND, the internal buffer is placed in a high-impedance mode, and the bus terminals supplied with power are placed in bus hold mode.

All inputs are equipped with protection circuits to protect the devices from electrostatic discharge damage.

3. Features

- (1) Wide operating temperature range: $T_{opr} = -40$ to 125 °C
- (2) Wide supply voltage value: $V_{CCA} = 0.7$ to 3.6 V, $V_{CCB} = 0.7$ to 3.6 V (Note1)
- (3) Bidirectional interface
- (4) High-speed operation: $t_{pd} = 3.6$ ns (max) ($V_{CCA} = 3.3 \pm 0.3$ V, $V_{CCB} = 3.3 \pm 0.3$ V)
- (5) Output current: $|I_{OH}|/|I_{OL}| = \pm 12$ mA (min) ($V_{CC} = 3.0$ V)
 $|I_{OH}|/|I_{OL}| = \pm 9$ mA (min) ($V_{CC} = 2.3$ V)
 $|I_{OH}|/|I_{OL}| = \pm 6$ mA (min) ($V_{CC} = 1.65$ V)
 $|I_{OH}|/|I_{OL}| = \pm 4$ mA (min) ($V_{CC} = 1.4$ V)
 $|I_{OH}|/|I_{OL}| = \pm 2$ mA (min) ($V_{CC} = 1.1$ V)
 $|I_{OH}|/|I_{OL}| = \pm 0.5$ mA (min) ($V_{CC} = 0.85$ V)
 $|I_{OH}|/|I_{OL}| = \pm 0.2$ mA (min) ($V_{CC} = 0.76$ V)
 $|I_{OH}|/|I_{OL}| = \pm 0.05$ mA (min) ($V_{CC} = 0.7$ V)
- (6) Small package: TSSOP16B
- (7) Low power dissipation: Suitable for battery-driven applications such as PDAs and cellular phones.
- (8) 3.6 V tolerance and power-down protection are provided to all inputs and outputs.

Note1: The operating voltage range of 0.7 V to 3.6 V applies to products manufactured after September 2025.

Start of commercial production
2024-09

4. Packaging

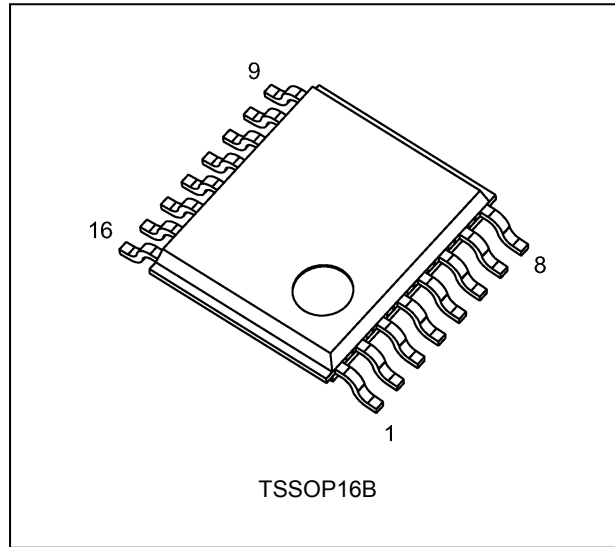

5. Pin Assignment

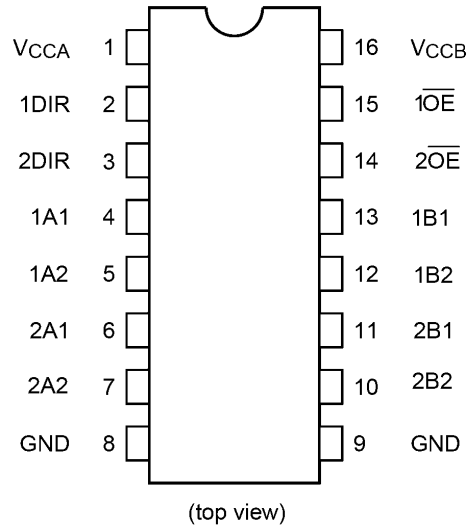

6. Marking

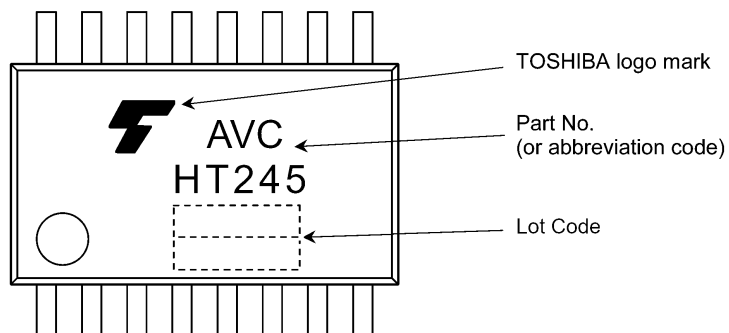

7. Block Diagram

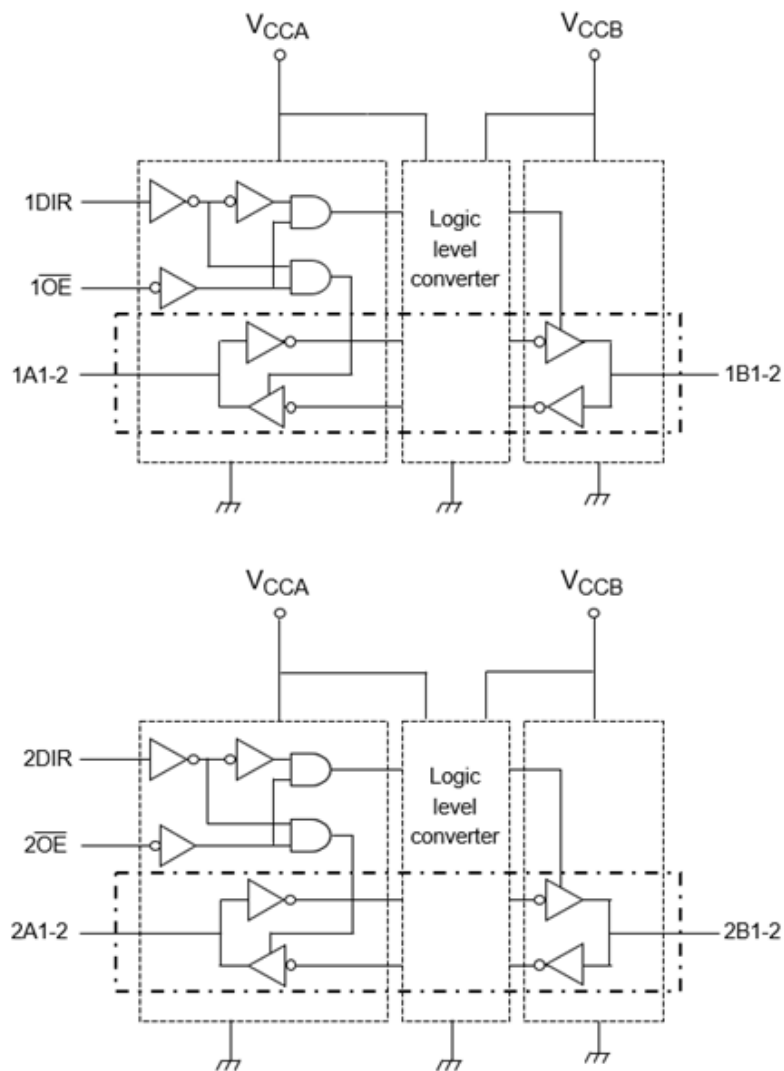

8. Truth Table

Supply voltage V_{CCA}	Supply voltage V_{CCB}	Input $n\overline{OE}$	Input $nDIR$	Input/Output Bus $nA1, nA2$	Input/Output Bus $nB1, nB2$	Function
0.7 to 3.6 V	0.7 to 3.6 V	L	L	Output	Input	$A = B$
0.7 to 3.6 V	0.7 to 3.6 V	L	H	Input	Output	$B = A$
0.7 to 3.6 V	0.7 to 3.6 V	H	X	Z	Z	Bus-Hold
GND	0.7 to 3.6 V	X	X	Z	Z	Bus-Hold
0.7 to 3.6 V	GND	X	X	Z	Z	Bus-Hold
GND	GND	X	X	Z	Z	Z

X: Don't care
Z: High impedance

9. Absolute Maximum Ratings (Note)

Characteristics	Symbol	Note	Rating	Unit
Supply voltage	V_{CCA}		-0.5 to 4.6	V
	V_{CCB}		-0.5 to 4.6	
Input voltage (nDIR, nOE)	V_{IN}		-0.5 to 4.6	V
Bus I/O voltage	$V_{I/OA}$	(Note 1)	-0.5 to 4.6	V
		(Note 2)	-0.5 to $V_{CCA} + 0.5$	
	$V_{I/OB}$	(Note 1)	-0.5 to 4.6	
		(Note 2)	-0.5 to $V_{CCB} + 0.5$	
Input diode current	I_{IK}		-50	mA
I/O diode current	$I_{I/OK}$	(Note 3)	-50	mA
Output current	I_{OUTA}		± 50	mA
	I_{OUTB}		± 50	
V_{CC} /ground current per supply pin	I_{CCA}		100	mA
	I_{CCB}		100	
Power dissipation	P_D	(Note 4)	180	mW
Storage temperature	T_{stg}		-65 to 150	°C

Note: Exceeding any of the absolute maximum ratings, even briefly, lead to deterioration in IC performance or even destruction.

Using continuously under heavy loads (e.g. the application of high temperature/current/voltage and the significant change in temperature, etc.) may cause this product to decrease in the reliability significantly even if the operating conditions (i.e. operating temperature/current/voltage, etc.) are within the absolute maximum ratings and the operating ranges.

Please design the appropriate reliability upon reviewing the Toshiba Semiconductor Reliability Handbook (“Handling Precautions”/“Derating Concept and Methods”) and individual reliability data (i.e. reliability test report and estimated failure rate, etc).

Note 1: High impedance state.

Note 2: Input/output state, bus hold state. IOUT absolute maximum rating must be observed.

Note 3: $V_{OUT} < GND$

Note 4: 180 mW in the range of $T_a = -40$ to 85 °C. From $T_a = 85$ to 125 °C a derating factor of -3.25 mW/°C shall be applied until 50 mW.

10. Operating Ranges (Note)

Characteristics	Symbol	Note	Test Condition	Rating	Unit
Supply voltage	V_{CCA}		—	0.7 to 3.6	V
	V_{CCB}		—	0.7 to 3.6	
Input voltage(nDIR, nOE)	V_{IN}		—	0 to 3.6	V
Bus I/O voltage	V_{IOA}	(Note 1)	—	0 to 3.6	V
		(Note 2)	—	0 to V_{CCA}	
	V_{IOB}	(Note 1)	—	0 to 3.6	
		(Note 2)	—	0 to V_{CCB}	
Output current	I_{OUTA}		$V_{CCA} = 3.0$ to 3.6 V	± 12	mA
			$V_{CCA} = 2.3$ to 2.7 V	± 9	
			$V_{CCA} = 1.65$ to 1.95 V	± 6	
			$V_{CCA} = 1.4$ to 1.6 V	± 4	
			$V_{CCA} = 1.1$ to 1.3 V	± 2	
			$V_{CCA} = 0.85$ to 0.95 V	± 0.5	
			$V_{CCA} = 0.76$ to 0.84 V	± 0.2	
			$V_{CCA} = 0.7$ V	± 0.05	
	I_{OUTB}		$V_{CCB} = 3.0$ to 3.6 V	± 12	
			$V_{CCB} = 2.3$ to 2.7 V	± 9	
			$V_{CCB} = 1.65$ to 1.95 V	± 6	
			$V_{CCB} = 1.4$ to 1.6 V	± 4	
			$V_{CCB} = 1.1$ to 1.3 V	± 2	
			$V_{CCA} = 0.85$ to 0.95 V	± 0.5	
			$V_{CCA} = 0.76$ to 0.84 V	± 0.2	
			$V_{CCA} = 0.7$ V	± 0.05	
Operating temperature	T_{opr}		—	-40 to 125	°C
Input rise and fall times	dt/dv	(Note 3)	$V_{CC} = 0.7$ V	0 to 20	ns/V
			$V_{CC} = 0.76$ to 1.6 V	0 to 20	
			$V_{CC} = 1.65$ to 1.95 V	0 to 20	
			$V_{CC} = 2.3$ to 2.7 V	0 to 20	
			$V_{CC} = 3.0$ to 3.6 V	0 to 10	

Note: The operating ranges must be maintained to ensure the normal operation of the device.

Unused inputs and bus inputs must be tied to either V_{CC} or GND.

Note 1: Input state or high impedance state.

Note 2: Input/output state, bus hold state. I_{OUT} absolute maximum rating must be observed.

Note 3: $V_{CC} = V_{CCA}, V_{CCB}$

11. Electrical Characteristics

11.1. DC Characteristics (Unless otherwise specified, $T_a = -40$ to 85 °C)

Characteristics	Symbol	Test Condition	V_{CCA} (V)	V_{CCB} (V)	Min	Max	Unit	
High-level input voltage	V_{IHA}	nA, nDIR, \overline{nOE}	0.7	0.7 to 3.6	$V_{CCA} \times 0.80$	—	V	
			0.8 to 1.95	0.7 to 3.6	$V_{CCA} \times 0.70$	—		
			2.3 to 2.7	0.7 to 3.6	1.6	—		
			3.0 to 3.6	0.7 to 3.6	2.0	—		
	V_{IHB}	nB	0.7 to 3.6	0.7	$V_{CCB} \times 0.80$	—		
			0.7 to 3.6	0.8 to 1.95	$V_{CCB} \times 0.70$	—		
			0.7 to 3.6	2.3 to 2.7	1.6	—		
			0.7 to 3.6	3.0 to 3.6	2.0	—		
Low-level input voltage	V_{ILA}	nA, nDIR, \overline{nOE}	0.7	0.7 to 3.6	—	$V_{CCA} \times 0.20$	V	
			0.8 to 1.95	0.7 to 3.6	—	$V_{CCA} \times 0.30$		
			2.3 to 2.7	0.7 to 3.6	—	0.7		
			3.0 to 3.6	0.7 to 3.6	—	0.9		
	V_{ILB}	nB	0.7 to 3.6	0.7	—	$V_{CCB} \times 0.20$		
			0.7 to 3.6	0.8 to 1.95	—	$V_{CCB} \times 0.30$		
			0.7 to 3.6	2.3 to 2.7	—	0.7		
			0.7 to 3.6	3.0 to 3.6	—	0.9		
High-level output voltage	V_{OH}	nA, nB Output H	$I_{OH} = -0.1$ mA	0.7 to 3.6	0.7 to 3.6	$V_{CCO} - 0.1$	—	V
			$I_{OH} = -0.2$ mA	0.76	0.76	0.58	—	
			$I_{OH} = -0.5$ mA	0.85	0.85	0.65	—	
			$I_{OH} = -2$ mA	1.1	1.1	0.85	—	
			$I_{OH} = -4$ mA	1.4	1.4	1.05	—	
			$I_{OH} = -6$ mA	1.65	1.65	1.2	—	
			$I_{OH} = -9$ mA	2.3	2.3	1.75	—	
			$I_{OH} = -12$ mA	3.0	3.0	2.3	—	
Low-level output voltage	V_{OL}	nA, nB Output L	$I_{OL} = 0.1$ mA	0.7 to 3.6	0.7 to 3.6	—	0.1	V
			$I_{OL} = 0.2$ mA	0.76	0.76	—	0.18	
			$I_{OL} = 0.5$ mA	0.85	0.85	—	0.2	
			$I_{OL} = 2$ mA	1.1	1.1	—	0.25	
			$I_{OL} = 4$ mA	1.4	1.4	—	0.35	
			$I_{OL} = 6$ mA	1.65	1.65	—	0.45	
			$I_{OL} = 9$ mA	2.3	2.3	—	0.55	
			$I_{OL} = 12$ mA	3.0	3.0	—	0.7	

Characteristics	Symbol	Test Condition	V _{CCA} (V)	V _{CCB} (V)	Min	Typ.	Max	Unit
Input leakage current	I _{IN}	Input = 0 V to 3.6 V	0.7 to 3.6	0 to 3.6	—	—	±1	μA
Bushold input minimum drive hold current	I _{I(HOLD)}	V _I = 0.21 V	0.7	0.7	1	—	—	μA
		V _I = 0.49 V	0.7	0.7	-1	—	—	
		V _I = 0.23 V	0.76	0.76	2	—	—	
		V _I = 0.53 V	0.76	0.76	-2	—	—	
		V _I = 0.26 V	0.85	0.85	5	—	—	
		V _I = 0.59 V	0.85	0.85	-5	—	—	
		V _I = 0.33 V	1.1	1.1	10	—	—	
		V _I = 0.77 V	1.1	1.1	-10	—	—	
		V _I = 0.42 V	1.4	1.4	15	—	—	
		V _I = 0.98 V	1.4	1.4	-15	—	—	
		V _I = 0.50 V	1.65	1.65	25	—	—	
		V _I = 1.15 V	1.65	1.65	-25	—	—	
		V _I = 0.7 V	2.3	2.3	45	—	—	
		V _I = 1.6 V	2.3	2.3	-45	—	—	
		V _I = 0.8 V	3.0	3.0	100	—	—	
		V _I = 2.0 V	3.0	3.0	-100	—	—	
Bushold input over-drive current to change state	I _{I(OD)}	V _I = L → H	0.7	0.7	20	—	—	μA
		V _I = H → L	0.7	0.7	-20	—	—	
		V _I = L → H	0.84	0.84	50	—	—	
		V _I = H → L	0.84	0.84	-50	—	—	
		V _I = L → H	0.95	0.95	65	—	—	
		V _I = H → L	0.95	0.95	-65	—	—	
		V _I = L → H	1.3	1.3	110	—	—	
		V _I = H → L	1.3	1.3	-110	—	—	
		V _I = L → H	1.6	1.6	150	—	—	
		V _I = H → L	1.6	1.6	-150	—	—	
		V _I = L → H	1.95	1.95	250	—	—	
		V _I = H → L	1.95	1.95	-250	—	—	
		V _I = L → H	2.7	2.7	400	—	—	
		V _I = H → L	2.7	2.7	-400	—	—	
		V _I = L → H	3.6	3.6	600	—	—	
		V _I = H → L	3.6	3.6	-600	—	—	
Power-OFF leakage current	I _{OFFA}	V _{IOA} = 0 V to 3.6 V	0	0.7 to 3.6	—	—	±5	μA
	I _{OFFB}	V _{IOB} = 0 V to 3.6 V	0.7 to 3.6	0	—	—	±5	
Quiescent supply current	I _{CCA}	—	0.7 to 3.6	0.7 to 3.6	—	—	8	μA
		—	3.6	0	—	—	8	
	I _{CCB}	—	0.7 to 3.6	0.7 to 3.6	—	—	8	
		—	0	3.6	—	—	8	

11.2. DC Characteristics (Unless otherwise specified, $T_a = -40$ to 125 °C)

Characteristics	Symbol	Test Condition	V_{CCA} (V)	V_{CCB} (V)	Min	Max	Unit	
High-level input voltage	V_{IHA}	nA, nDIR, \overline{nOE}	0.7	0.7 to 3.6	$V_{CCA} \times 0.80$	—	V	
			0.8 to 1.95	0.7 to 3.6	$V_{CCA} \times 0.70$	—		
			2.3 to 2.7	0.7 to 3.6	1.6	—		
			3.0 to 3.6	0.7 to 3.6	2.0	—		
	V_{IHB}	nB	0.7 to 3.6	0.7	$V_{CCB} \times 0.80$	—		
			0.7 to 3.6	0.8 to 1.95	$V_{CCB} \times 0.70$	—		
			0.7 to 3.6	2.3 to 2.7	1.6	—		
			0.7 to 3.6	3.0 to 3.6	2.0	—		
Low-level input voltage	V_{ILA}	nA, nDIR, \overline{nOE}	0.7	0.7 to 3.6	—	$V_{CCA} \times 0.20$	V	
			0.8 to 1.95	0.7 to 3.6	—	$V_{CCA} \times 0.30$		
			2.3 to 2.7	0.7 to 3.6	—	0.7		
			3.0 to 3.6	0.7 to 3.6	—	0.9		
	V_{ILB}	nB	0.7 to 3.6	0.7	—	$V_{CCB} \times 0.20$		
			0.7 to 3.6	0.8 to 1.95	—	$V_{CCB} \times 0.30$		
			0.7 to 3.6	2.3 to 2.7	—	0.7		
			0.7 to 3.6	3.0 to 3.6	—	0.9		
High-level output voltage	V_{OH}	nA, nB Output H	$I_{OH} = -0.1$ mA	0.7 to 3.6	0.7 to 3.6	$V_{CCO} - 0.1$	—	V
			$I_{OH} = -0.2$ mA	0.76	0.76	0.58	—	
			$I_{OH} = -0.5$ mA	0.85	0.85	0.65	—	
			$I_{OH} = -2$ mA	1.1	1.1	0.85	—	
			$I_{OH} = -4$ mA	1.4	1.4	1.05	—	
			$I_{OH} = -6$ mA	1.65	1.65	1.2	—	
			$I_{OH} = -9$ mA	2.3	2.3	1.75	—	
			$I_{OH} = -12$ mA	3.0	3.0	2.3	—	
Low-level output voltage	V_{OL}	nA, nB Output L	$I_{OL} = 0.1$ mA	0.7 to 3.6	0.7 to 3.6	—	0.1	V
			$I_{OL} = 0.2$ mA	0.76	0.76	—	0.18	
			$I_{OL} = 0.5$ mA	0.85	0.85	—	0.2	
			$I_{OL} = 2$ mA	1.1	1.1	—	0.25	
			$I_{OL} = 4$ mA	1.4	1.4	—	0.35	
			$I_{OL} = 6$ mA	1.65	1.65	—	0.45	
			$I_{OL} = 9$ mA	2.3	2.3	—	0.55	
			$I_{OL} = 12$ mA	3.0	3.0	—	0.7	

Characteristics	Symbol	Test Condition	V _{CCA} (V)	V _{CCB} (V)	Min	Typ.	Max	Unit
Input leakage current	I _{IN}	V _{IN(DIR)} = 0 to 3.6 V	0.7 to 3.6	0.7 to 3.6	—	—	±5	μA
Bushold input minimum drive hold current	I _{I(HOLD)}	V _{IN} = 0.21 V	0.7	0.7	1	—	—	μA
		V _{IN} = 0.49 V	0.7	0.7	-1	—	—	
		V _{IN} = 0.23 V	0.76	0.76	2	—	—	
		V _{IN} = 0.53 V	0.76	0.76	-2	—	—	
		V _{IN} = 0.26 V	0.85	0.85	5	—	—	
		V _{IN} = 0.59 V	0.85	0.85	-5	—	—	
		V _{IN} = 0.33 V	1.1	1.1	10	—	—	
		V _{IN} = 0.77 V	1.1	1.1	-10	—	—	
		V _{IN} = 0.42 V	1.4	1.4	15	—	—	
		V _{IN} = 0.98 V	1.4	1.4	-15	—	—	
		V _{IN} = 0.50 V	1.65	1.65	25	—	—	
		V _{IN} = 1.15 V	1.65	1.65	-25	—	—	
		V _{IN} = 0.7 V	2.3	2.3	45	—	—	
		V _{IN} = 1.6 V	2.3	2.3	-45	—	—	
		V _{IN} = 0.7 V	3.0	3.0	100	—	—	
		V _{IN} = 2.0 V	3.0	3.0	-100	—	—	
Bushold input over-drive current to change state	I _{I(OD)}	V _{IN} = L → H	0.7	0.7	20	—	—	μA
		V _{IN} = H → L	0.7	0.7	-20	—	—	
		V _{IN} = L → H	0.84	0.84	50	—	—	
		V _{IN} = H → L	0.84	0.84	-50	—	—	
		V _{IN} = L → H	0.95	0.95	65	—	—	
		V _{IN} = H → L	0.95	0.95	-65	—	—	
		V _{IN} = L → H	1.3	1.3	110	—	—	
		V _{IN} = H → L	1.3	1.3	-110	—	—	
		V _{IN} = L → H	1.6	1.6	150	—	—	
		V _{IN} = H → L	1.6	1.6	-150	—	—	
		V _{IN} = L → H	1.95	1.95	250	—	—	
		V _{IN} = H → L	1.95	1.95	-250	—	—	
		V _{IN} = L → H	2.7	2.7	400	—	—	
		V _{IN} = H → L	2.7	2.7	-400	—	—	
		V _{IN} = L → H	3.6	3.6	600	—	—	
		V _{IN} = H → L	3.6	3.6	-600	—	—	
Power-OFF leakage current	I _{OFFA}	V _{IOA} = 0 V to 3.6 V	0	0.7 to 3.6	—	—	±10	μA
	I _{OFFB}	V _{IOB} = 0 V to 3.6 V	0.7 to 3.6	0	—	—	±10	
Quiescent supply current	I _{CCA}	—	0.7 to 3.6	0.8 to 3.6	—	—	18	μA
		—	3.6	0	—	—	18	
	I _{CCB}	—	0.7 to 3.6	0.7 to 3.6	—	—	18	
		—	0	3.6	—	—	18	

11.3. AC Characteristics (Note) ($V_{CCA} = 0.7 \text{ V}$, $T_a = 25 \text{ }^\circ\text{C}$)

Characteristics	Symbol	V_{CCB} 0.7 V Typ.	V_{CCB} 0.8 V Typ.	V_{CCB} 0.9 V Typ.	V_{CCB} 1.2 V Typ.	V_{CCB} 1.5 V Typ.	V_{CCB} 1.8 V Typ.	V_{CCB} 2.5 V Typ.	V_{CCB} 3.3 V Typ.	Unit
Propagation delay time(B → A)	t_{PLH}/t_{PHL}	16.2	14.1	13.0	11.9	11.0	10.6	10.6	11.1	ns
Propagation delay time (B → A)		16.2	13.5	12.0	10.0	9.2	8.8	8.3	8.1	
3-state output disable time ($\overline{OE} \rightarrow A$)	t_{PLZ}/t_{PHZ}	24.1	24.1	24.1	24.1	24.1	24.1	24.0	23.2	
3-state output disable time ($\overline{OE} \rightarrow B$)		25.9	21.7	19.7	13.0	12.0	12.3	11.9	12.8	
3-state output enable time ($\overline{OE} \rightarrow A$)	t_{PZL}/t_{PZH}	26.9	26.9	26.9	26.9	26.9	26.9	26.8	26.7	
3-state output enable time ($\overline{OE} \rightarrow B$)		44.6	34.0	28.4	22.1	19.5	18.3	17.7	17.8	

Note: See Figure 12.1, 13.1, 13.2, table 12.1.1, 12.1.2, 13.1.1 for the measurement circuit.

11.4. AC Characteristics (Note) ($V_{CCB} = 0.7 \text{ V}$, $T_a = 25 \text{ }^\circ\text{C}$)

Characteristics	Symbol	V_{CCA} 0.7 V Typ.	V_{CCA} 0.8 V Typ.	V_{CCA} 0.9 V Typ.	V_{CCA} 1.2 V Typ.	V_{CCA} 1.5 V Typ.	V_{CCA} 1.8 V Typ.	V_{CCA} 2.5 V Typ.	V_{CCA} 3.3 V Typ.	Unit
Propagation delay time (A → B)	t_{PLH}/t_{PHL}	16.2	13.5	12.0	10.0	9.2	8.8	8.3	8.1	ns
Propagation delay time (B → A)		16.2	14.1	13.0	11.9	11.0	10.6	10.6	11.1	
3-state output disable time ($\overline{OE} \rightarrow A$)	t_{PLZ}/t_{PHZ}	24.1	18.6	15.0	6.8	5.1	4.8	3.4	3.7	
3-state output disable time ($\overline{OE} \rightarrow B$)		25.9	22.8	21.5	19.8	19.1	18.5	17.7	17.4	
3-state output enable time ($\overline{OE} \rightarrow A$)	t_{PZL}/t_{PZH}	26.9	18.7	14.3	9.4	7.1	6.1	5.2	5.1	
3-state output enable time ($\overline{OE} \rightarrow B$)		44.6	41.2	39.6	37.6	37.2	37.1	37.2	37.2	

Note: See Figure 12.1, 13.1, 13.2, table 12.1.1, 12.1.2, 13.1.1 for the measurement circuit.

11.5. AC Characteristics (Note) ($V_{CCA} = 0.7 \text{ V}$, $T_a = -40 \text{ to } 85 \text{ }^\circ\text{C}$)

Characteristics	Symbol	V_{CCB} 0.7 V Max	V_{CCB} $0.8 \pm 0.04 \text{ V}$ Max	V_{CCB} $0.9 \pm 0.045 \text{ V}$ Max	V_{CCB} $1.2 \pm 0.1 \text{ V}$ Max	V_{CCB} $1.5 \pm 0.1 \text{ V}$ Max	V_{CCB} $1.8 \pm 0.15 \text{ V}$ Max	V_{CCB} $2.5 \pm 0.2 \text{ V}$ Max	V_{CCB} $3.3 \pm 0.3 \text{ V}$ Max	Unit
Propagation delay time (A → B)	t_{PLH}/t_{PHL}	40.9	33.9	28.7	24.4	23.2	23.1	25.3	31.2	ns
Propagation delay time (B → A)		40.9	33.7	29.1	24.4	22.9	22.5	22.0	21.7	
3-state output disable time ($\overline{OE} \rightarrow A$)	t_{PLZ}/t_{PHZ}	49.5	49.5	49.5	49.5	49.5	49.5	49.5	49.5	
3-state output disable time ($\overline{OE} \rightarrow B$)		51.9	42.5	34.8	26.3	24.3	24.5	25.1	27.4	
3-state output enable time ($\overline{OE} \rightarrow A$)	t_{PZL}/t_{PZH}	68.5	68.5	68.5	68.5	68.5	68.5	68.5	68.5	
3-state output enable time ($\overline{OE} \rightarrow B$)		117.4	86.3	63.5	45.7	40.0	38.4	38.4	40.1	

Note: See Figure 12.1, 13.1, 13.2, table 12.1.1, 12.1.2, 13.1.1 for the measurement circuit.

11.6. AC Characteristics (Note) ($V_{CCA} = 0.8 \pm 0.04 \text{ V}$, $T_a = -40 \text{ to } 85 \text{ }^\circ\text{C}$)

Characteristics	Symbol	V_{CCB} 0.7 V Max	V_{CCB} $0.8 \pm 0.04 \text{ V}$ Max	V_{CCB} $0.9 \pm 0.045 \text{ V}$ Max	V_{CCB} $1.2 \pm 0.1 \text{ V}$ Max	V_{CCB} $1.5 \pm 0.1 \text{ V}$ Max	V_{CCB} $1.8 \pm 0.15 \text{ V}$ Max	V_{CCB} $2.5 \pm 0.2 \text{ V}$ Max	V_{CCB} $3.3 \pm 0.3 \text{ V}$ Max	Unit
Propagation delay time (A → B)	t_{PLH}/t_{PHL}	33.7	26.9	21.6	18.2	16.4	16.0	16.5	17.8	ns
Propagation delay time (B → A)		33.9	26.9	22.0	17.4	16.1	15.6	15.1	14.9	
3-state output disable time ($\overline{OE} \rightarrow A$)	t_{PLZ}/t_{PHZ}	34.6	34.6	34.6	34.6	34.6	34.6	34.6	34.6	
3-state output disable time ($\overline{OE} \rightarrow B$)		46.0	36.6	28.7	20.0	17.9	17.9	17.5	19.1	
3-state output enable time ($\overline{OE} \rightarrow A$)	t_{PZL}/t_{PZH}	44.8	44.8	44.8	44.8	44.8	44.8	44.8	44.8	
3-state output enable time ($\overline{OE} \rightarrow B$)		107.9	76.4	53.3	35.6	29.6	27.6	26.6	27.2	

Note: See Figure 12.1, 13.1, 13.2, table 12.1.1, 12.1.2, 13.1.1 for the measurement circuit.

11.7. AC Characteristics (Note) ($V_{CCA} = 0.9 \pm 0.045 \text{ V}$, $T_a = -40 \text{ to } 85 \text{ }^\circ\text{C}$)

Characteristics	Symbol	V_{CCB} 0.7 V	V_{CCB} $0.8 \pm$ 0.04 V	V_{CCB} $0.9 \pm$ 0.045 V	V_{CCB} $1.2 \pm$ 0.1 V	V_{CCB} $1.5 \pm$ 0.1 V	V_{CCB} $1.8 \pm$ 0.15 V	V_{CCB} $2.5 \pm$ 0.2 V	V_{CCB} $3.3 \pm$ 0.3 V	Unit
		Max	Max	Max	Max	Max	Max	Max	Max	
Propagation delay time (A → B)	t_{PLH}/t_{PHL}	29.1	22.0	16.6	13.9	12.2	11.2	10.9	11.0	ns
Propagation delay time (B → A)		28.7	21.6	16.6	12.5	11.1	10.5	9.8	9.5	
3-state output disable time ($\overline{OE} \rightarrow A$)	t_{PLZ}/t_{PHZ}	22.9	22.9	22.9	22.9	22.9	22.9	22.9	22.9	
3-state output disable time ($\overline{OE} \rightarrow B$)		40.9	31.9	24.0	15.9	13.4	13.1	12.0	13.1	
3-state output enable time ($\overline{OE} \rightarrow A$)	t_{PZL}/t_{PZH}	27.8	27.8	27.8	27.8	27.8	27.8	27.8	27.8	
3-state output enable time ($\overline{OE} \rightarrow B$)		101.6	69.7	46.3	30.1	23.7	21.2	18.8	17.9	

Note: See Figure 12.1, 13.1, 13.2, table 12.1.1, 12.1.2, 13.1.1 for the measurement circuit.

11.8. AC Characteristics (Note) ($V_{CCA} = 1.2 \pm 0.1 \text{ V}$, $T_a = -40 \text{ to } 85 \text{ }^\circ\text{C}$)

Characteristics	Symbol	V_{CCB} 0.7 V	V_{CCB} $0.8 \pm$ 0.04 V	V_{CCB} $0.9 \pm$ 0.045 V	V_{CCB} $1.2 \pm$ 0.1 V	V_{CCB} $1.5 \pm$ 0.1 V	V_{CCB} $1.8 \pm$ 0.15 V	V_{CCB} $2.5 \pm$ 0.2 V	V_{CCB} $3.3 \pm$ 0.3 V	Unit
		Max	Max	Max	Max	Max	Max	Max	Max	
Propagation delay time (A → B)	t_{PLH}/t_{PHL}	24.4	17.4	12.5	10.2	9.0	8.5	7.6	7.3	ns
Propagation delay time (B → A)		24.4	18.2	13.9	10.2	8.2	7.5	6.7	6.4	
3-state output disable time ($\overline{OE} \rightarrow A$)	t_{PLZ}/t_{PHZ}	12.3	12.2	12.2	12.2	12.2	12.2	12.2	12.3	
3-state output disable time ($\overline{OE} \rightarrow B$)		37.1	27.4	21.1	13.6	10.8	9.5	7.9	7.3	
3-state output enable time ($\overline{OE} \rightarrow A$)	t_{PZL}/t_{PZH}	18.0	17.9	17.8	17.7	18.0	18.0	18.0	18.1	
3-state output enable time ($\overline{OE} \rightarrow B$)		97.1	64.3	40.3	27.7	20.0	17.0	13.7	12.5	

Note: See Figure 12.1, 13.1, 13.2, table 12.1.1, 12.1.2, 13.1.1 for the measurement circuit.

11.9. AC Characteristics (Note) ($V_{CCA} = 1.5 \pm 0.1 \text{ V}$, $T_a = -40 \text{ to } 85 \text{ }^\circ\text{C}$)

Characteristics	Symbol	V_{CCB} 0.7 V	V_{CCB} $0.8 \pm$ 0.04 V	V_{CCB} $0.9 \pm$ 0.045 V	V_{CCB} $1.2 \pm$ 0.1 V	V_{CCB} $1.5 \pm$ 0.1 V	V_{CCB} $1.8 \pm$ 0.15 V	V_{CCB} $2.5 \pm$ 0.2 V	V_{CCB} $3.3 \pm$ 0.3 V	Unit
		Max	Max	Max	Max	Max	Max	Max	Max	
Propagation delay time (A → B)	t_{PLH}/t_{PHL}	22.9	16.1	11.1	8.2	6.9	6.5	5.9	5.5	ns
Propagation delay time (B → A)		23.2	16.4	12.2	9.0	6.9	6.0	5.2	4.9	
3-state output disable time ($\overline{OE} \rightarrow A$)	t_{PLZ}/t_{PHZ}	8.5	8.4	8.4	8.4	8.4	8.4	8.3	8.2	
3-state output disable time ($\overline{OE} \rightarrow B$)		35.9	25.9	20.0	12.1	9.1	7.6	6.1	5.4	
3-state output enable time ($\overline{OE} \rightarrow A$)	t_{PZL}/t_{PZH}	11.9	11.8	11.7	11.6	11.7	11.9	11.8	11.8	
3-state output enable time ($\overline{OE} \rightarrow B$)		95.9	63.0	38.7	25.1	17.4	14.4	11.0	9.7	

Note: See Figure 12.1, 13.1, 13.2, table 12.1.1, 12.1.2, 13.1.1 for the measurement circuit.

11.10. AC Characteristics (Note) ($V_{CCA} = 1.8 \pm 0.15 \text{ V}$, $T_a = -40 \text{ to } 85 \text{ }^\circ\text{C}$)

Characteristics	Symbol	V_{CCB} 0.7 V	V_{CCB} $0.8 \pm$ 0.04 V	V_{CCB} $0.9 \pm$ 0.045 V	V_{CCB} $1.2 \pm$ 0.1 V	V_{CCB} $1.5 \pm$ 0.1 V	V_{CCB} $1.8 \pm$ 0.15 V	V_{CCB} $2.5 \pm$ 0.2 V	V_{CCB} $3.3 \pm$ 0.3 V	Unit
		Max	Max	Max	Max	Max	Max	Max	Max	
Propagation delay time (A → B)	t_{PLH}/t_{PHL}	22.5	15.6	10.5	7.5	6.0	5.5	5.1	4.8	ns
Propagation delay time (B → A)		23.1	16.0	11.2	8.5	6.5	5.5	4.6	4.3	
3-state output disable time ($\overline{OE} \rightarrow A$)	t_{PLZ}/t_{PHZ}	7.3	7.3	7.3	7.3	7.3	7.3	7.3	7.2	
3-state output disable time ($\overline{OE} \rightarrow B$)		35.3	25.5	19.7	12.6	9.3	7.7	6.0	5.2	
3-state output enable time ($\overline{OE} \rightarrow A$)	t_{PZL}/t_{PZH}	9.4	9.3	9.2	9.2	9.2	9.3	9.3	9.3	
3-state output enable time ($\overline{OE} \rightarrow B$)		95.9	62.9	38.2	24.2	16.5	13.4	10.0	8.6	

Note: See Figure 12.1, 13.1, 13.2, table 12.1.1, 12.1.2, 13.1.1 for the measurement circuit.

11.11. AC Characteristics (Note) ($V_{CCA} = 2.5 \pm 0.2 \text{ V}$, $T_a = -40 \text{ to } 85 \text{ }^\circ\text{C}$)

Characteristics	Symbol	V_{CCB} 0.7 V	V_{CCB} $0.8 \pm 0.04 \text{ V}$	V_{CCB} $0.9 \pm 0.045 \text{ V}$	V_{CCB} $1.2 \pm 0.1 \text{ V}$	V_{CCB} $1.5 \pm 0.1 \text{ V}$	V_{CCB} $1.8 \pm 0.15 \text{ V}$	V_{CCB} $2.5 \pm 0.2 \text{ V}$	V_{CCB} $3.3 \pm 0.3 \text{ V}$	Unit
		Max	Max	Max	Max	Max	Max	Max	Max	
Propagation delay time (A → B)	t_{PLH}/t_{PHL}	22.0	15.1	9.8	6.7	5.2	4.6	4.0	3.9	ns
Propagation delay time (B → A)		25.3	16.5	10.9	7.6	5.9	5.1	4.0	3.5	
3-state output disable time ($\overline{OE} \rightarrow A$)	t_{PLZ}/t_{PHZ}	5.1	5.1	5.1	4.9	4.9	4.9	4.9	4.9	
3-state output disable time ($\overline{OE} \rightarrow B$)		34.0	24.6	18.7	11.8	8.5	7.0	5.3	4.5	
3-state output enable time ($\overline{OE} \rightarrow A$)	t_{PZL}/t_{PZH}	8.1	7.7	7.4	6.7	6.5	6.5	6.5	6.5	
3-state output enable time ($\overline{OE} \rightarrow B$)		97.3	63.4	38.3	23.7	15.8	12.5	9.0	7.5	

Note: See Figure 12.1, 13.1, 13.2, table 12.1.1, 12.1.2, 13.1.1 for the measurement circuit.

11.12. AC Characteristics (Note) ($V_{CCA} = 3.3 \text{ V}$, $T_a = -40 \text{ to } 85 \text{ }^\circ\text{C}$)

Characteristics	Symbol	V_{CCB} 0.7 V	V_{CCB} $0.8 \pm 0.04 \text{ V}$	V_{CCB} $0.9 \pm 0.045 \text{ V}$	V_{CCB} $1.2 \pm 0.1 \text{ V}$	V_{CCB} $1.5 \pm 0.1 \text{ V}$	V_{CCB} $1.8 \pm 0.15 \text{ V}$	V_{CCB} $2.5 \pm 0.2 \text{ V}$	V_{CCB} $3.3 \pm 0.3 \text{ V}$	Unit
		Max	Max	Max	Max	Max	Max	Max	Max	
Propagation delay time (A → B)	t_{PLH}/t_{PHL}	21.7	14.9	9.5	6.4	4.9	4.3	3.5	3.3	ns
Propagation delay time (B → A)		31.2	17.8	11.0	7.3	5.5	4.8	3.9	3.3	
3-state output disable time ($\overline{OE} \rightarrow A$)	t_{PLZ}/t_{PHZ}	5.2	5.2	5.2	5.0	5.0	5.0	5.0	5.0	
3-state output disable time ($\overline{OE} \rightarrow B$)		34.6	24.2	18.6	15.7	11.4	9.3	6.5	5.3	
3-state output enable time ($\overline{OE} \rightarrow A$)	t_{PZL}/t_{PZH}	7.1	6.4	6.1	5.9	5.3	5.3	5.2	5.2	
3-state output enable time ($\overline{OE} \rightarrow B$)		98.5	64.0	38.5	23.7	15.5	12.1	8.6	7.1	

Note: See Figure 12.1, 13.1, 13.2, table 12.1.1, 12.1.2, 13.1.1 for the measurement circuit.

11.13. AC Characteristics (Note) ($V_{CCA} = 0.7 \text{ V}$, $T_a = -40 \text{ to } 125 \text{ }^\circ\text{C}$)

Characteristics	Symbol	V_{CCB} 0.7 V	V_{CCB} $0.8 \pm 0.04 \text{ V}$	V_{CCB} $0.9 \pm 0.045 \text{ V}$	V_{CCB} $1.2 \pm 0.1 \text{ V}$	V_{CCB} $1.5 \pm 0.1 \text{ V}$	V_{CCB} $1.8 \pm 0.15 \text{ V}$	V_{CCB} $2.5 \pm 0.2 \text{ V}$	V_{CCB} $3.3 \pm 0.3 \text{ V}$	Unit
		Max	Max	Max	Min	Min	Min	Min	Min	
Propagation delay time (A → B)	t_{PLH}/t_{PHL}	40.9	33.9	28.7	24.4	23.2	23.1	25.3	31.2	ns
Propagation delay time (B → A)		40.9	33.7	29.1	24.4	22.9	22.5	22.0	21.7	
3-state output disable time ($\overline{OE} \rightarrow A$)	t_{PLZ}/t_{PHZ}	49.5	49.5	49.5	49.5	49.5	49.5	49.5	49.5	
3-state output disable time ($\overline{OE} \rightarrow B$)		51.9	42.5	34.8	26.3	24.3	24.5	25.1	27.4	
3-state output enable time ($\overline{OE} \rightarrow A$)	t_{PZL}/t_{PZH}	68.5	68.5	68.5	68.5	68.5	68.5	68.5	68.5	
3-state output enable time ($\overline{OE} \rightarrow B$)		117.4	86.3	63.5	45.7	40.0	38.4	38.4	40.1	

Note: See Figure 12.1, 13.1, 13.2, table 12.1.1, 12.1.2, 13.1.1 for the measurement circuit.

11.14. AC Characteristics (Note) ($V_{CCA} = 0.8 \pm 0.04 \text{ V}$, $T_a = -40 \text{ to } 125 \text{ }^\circ\text{C}$)

Characteristics	Symbol	V_{CCB} 0.7 V	V_{CCB} $0.8 \pm 0.04 \text{ V}$	V_{CCB} $0.9 \pm 0.045 \text{ V}$	V_{CCB} $1.2 \pm 0.1 \text{ V}$	V_{CCB} $1.5 \pm 0.1 \text{ V}$	V_{CCB} $1.8 \pm 0.15 \text{ V}$	V_{CCB} $2.5 \pm 0.2 \text{ V}$	V_{CCB} $3.3 \pm 0.3 \text{ V}$	Unit
		Max	Max	Max	Max	Max	Max	Max	Max	
Propagation delay time (A → B)	t_{PLH}/t_{PHL}	33.7	26.9	21.6	18.2	16.4	16.0	16.5	17.8	ns
Propagation delay time (B → A)		33.9	26.9	22.0	17.4	16.1	15.6	15.1	14.9	
3-state output disable time ($\overline{OE} \rightarrow A$)	t_{PLZ}/t_{PHZ}	34.6	34.6	34.6	34.6	34.6	34.6	34.6	34.6	
3-state output disable time ($\overline{OE} \rightarrow B$)		46.0	36.6	28.7	20.0	17.9	17.9	17.5	19.1	
3-state output enable time ($\overline{OE} \rightarrow A$)	t_{PZL}/t_{PZH}	44.8	44.8	44.8	44.8	44.8	44.8	44.8	44.8	
3-state output enable time ($\overline{OE} \rightarrow B$)		107.9	76.4	53.3	35.6	29.6	27.6	26.6	27.2	

Note: See Figure 12.1, 13.1, 13.2, table 12.1.1, 12.1.2, 13.1.1 for the measurement circuit.

11.15. AC Characteristics (Note) ($V_{CCA} = 0.9 \pm 0.045 \text{ V}$, $T_a = -40 \text{ to } 125 \text{ }^\circ\text{C}$)

Characteristics	Symbol	V_{CCB} 0.7 V	V_{CCB} $0.8 \pm$ 0.04 V	V_{CCB} $0.9 \pm$ 0.045 V	V_{CCB} $1.2 \pm$ 0.1 V	V_{CCB} $1.5 \pm$ 0.1 V	V_{CCB} $1.8 \pm$ 0.15 V	V_{CCB} $2.5 \pm$ 0.2 V	V_{CCB} $3.3 \pm$ 0.3 V	Unit
		Max	Max	Max	Max	Max	Max	Max	Max	
Propagation delay time (A → B)	t_{PLH}/t_{PHL}	29.1	22.0	16.6	14.1	12.5	11.4	10.9	11.0	ns
Propagation delay time (B → A)		28.7	21.6	16.6	12.5	11.1	10.6	9.8	9.5	
3-state output disable time ($\overline{OE} \rightarrow A$)	t_{PLZ}/t_{PHZ}	22.9	22.9	22.9	22.9	22.9	22.9	22.9	22.9	
3-state output disable time ($\overline{OE} \rightarrow B$)		40.9	31.9	24.0	15.9	13.4	13.1	12.0	13.1	
3-state output enable time ($\overline{OE} \rightarrow A$)	t_{PZL}/t_{PZH}	27.8	27.8	27.8	27.8	27.8	27.8	27.8	27.8	
3-state output enable time ($\overline{OE} \rightarrow B$)		101.6	69.7	46.3	30.1	23.7	21.2	18.8	17.9	

Note: See Figure 12.1, 13.1, 13.2, table 12.1.1, 12.1.2, 13.1.1 for the measurement circuit.

11.16. AC Characteristics (Note) ($V_{CCA} = 1.2 \pm 0.1 \text{ V}$, $T_a = -40 \text{ to } 125 \text{ }^\circ\text{C}$)

Characteristics	Symbol	V_{CCB} 0.7 V	V_{CCB} $0.8 \pm$ 0.04 V	V_{CCB} $0.9 \pm$ 0.045 V	V_{CCB} $1.2 \pm$ 0.1 V	V_{CCB} $1.5 \pm$ 0.1 V	V_{CCB} $1.8 \pm$ 0.15 V	V_{CCB} $2.5 \pm$ 0.2 V	V_{CCB} $3.3 \pm$ 0.3 V	Unit
		Max	Max	Max	Max	Max	Max	Max	Max	
Propagation delay time (A → B)	t_{PLH}/t_{PHL}	24.4	17.4	12.5	10.5	9.4	8.9	7.9	7.6	ns
Propagation delay time (B → A)		24.4	18.2	14.1	10.5	8.6	7.9	7.0	6.7	
3-state output disable time ($\overline{OE} \rightarrow A$)	t_{PLZ}/t_{PHZ}	12.6	12.5	12.5	12.5	12.5	12.5	12.5	12.6	
3-state output disable time ($\overline{OE} \rightarrow B$)		37.1	27.4	21.1	14.1	11.3	10.0	8.2	7.6	
3-state output enable time ($\overline{OE} \rightarrow A$)	t_{PZL}/t_{PZH}	18.5	18.4	18.4	18.2	18.5	18.6	18.6	18.7	
3-state output enable time ($\overline{OE} \rightarrow B$)		97.1	64.3	40.3	28.6	21.0	18.0	14.5	13.1	

Note: See Figure 12.1, 13.1, 13.2, table 12.1.1, 12.1.2, 13.1.1 for the measurement circuit.

11.17. AC Characteristics (Note) ($V_{CCA} = 1.5 \pm 0.1 \text{ V}$, $T_a = -40 \text{ to } 125 \text{ }^\circ\text{C}$)

Characteristics	Symbol	V_{CCB} 0.7 V	V_{CCB} $0.8 \pm$ 0.04 V	V_{CCB} $0.9 \pm$ 0.045 V	V_{CCB} $1.2 \pm$ 0.1 V	V_{CCB} $1.5 \pm$ 0.1 V	V_{CCB} $1.8 \pm$ 0.15 V	V_{CCB} $2.5 \pm$ 0.2 V	V_{CCB} $3.3 \pm$ 0.3 V	Unit
		Max	Max	Max	Max	Max	Max	Max	Max	
Propagation delay time (A → B)	t_{PLH}/t_{PHL}	22.9	16.1	11.1	8.6	7.3	6.9	6.3	5.8	ns
Propagation delay time (B → A)		23.2	16.4	12.5	9.4	7.3	6.4	5.5	5.2	
3-state output disable time ($\overline{OE} \rightarrow A$)	t_{PLZ}/t_{PHZ}	8.9	8.9	8.8	8.8	8.9	8.8	8.8	8.7	
3-state output disable time ($\overline{OE} \rightarrow B$)		35.9	25.9	20.0	12.8	9.6	8.0	6.4	5.7	
3-state output enable time ($\overline{OE} \rightarrow A$)	t_{PZL}/t_{PZH}	12.7	12.6	12.4	12.3	12.5	12.6	12.5	12.5	
3-state output enable time ($\overline{OE} \rightarrow B$)		95.9	63.0	38.7	26.2	18.4	15.4	11.8	10.3	

Note: See Figure 12.1, 13.1, 13.2, table 12.1.1, 12.1.2, 13.1.1 for the measurement circuit.

11.18. AC Characteristics (Note) ($V_{CCA} = 1.8 \pm 0.15 \text{ V}$, $T_a = -40 \text{ to } 125 \text{ }^\circ\text{C}$)

Characteristics	Symbol	V_{CCB} 0.7 V	V_{CCB} $0.8 \pm$ 0.04 V	V_{CCB} $0.9 \pm$ 0.045 V	V_{CCB} $1.2 \pm$ 0.1 V	V_{CCB} $1.5 \pm$ 0.1 V	V_{CCB} $1.8 \pm$ 0.15 V	V_{CCB} $2.5 \pm$ 0.2 V	V_{CCB} $3.3 \pm$ 0.3 V	Unit
		Max	Max	Max	Max	Max	Max	Max	Max	
Propagation delay time (A → B)	t_{PLH}/t_{PHL}	22.5	15.6	10.6	7.9	6.4	5.9	5.5	5.1	ns
Propagation delay time (B → A)		23.1	16.0	11.4	8.9	6.9	5.9	4.9	4.6	
3-state output disable time ($\overline{OE} \rightarrow A$)	t_{PLZ}/t_{PHZ}	7.7	7.7	7.7	7.7	7.7	7.6	7.6	7.5	
3-state output disable time ($\overline{OE} \rightarrow B$)		35.3	25.5	19.7	13.4	9.8	8.1	6.3	5.5	
3-state output enable time ($\overline{OE} \rightarrow A$)	t_{PZL}/t_{PZH}	10.0	9.9	9.8	9.9	9.9	9.9	10.0	10.0	
3-state output enable time ($\overline{OE} \rightarrow B$)		95.9	62.9	38.2	25.1	17.5	14.4	10.7	9.2	

Note: See Figure 12.1, 13.1, 13.2, table 12.1.1, 12.1.2, 13.1.1 for the measurement circuit.

11.19. AC Characteristics (Note) ($V_{CCA} = 2.5 \pm 0.2 \text{ V}$, $T_a = -40 \text{ to } 125 \text{ }^\circ\text{C}$)

Characteristics	Symbol	V_{CCB}	V_{CCB}	V_{CCB}	V_{CCB}	V_{CCB}	V_{CCB}	V_{CCB}	V_{CCB}	Unit
		0.7 V Max	$0.8 \pm 0.04 \text{ V}$ Max	$0.9 \pm 0.045 \text{ V}$ Max	$1.2 \pm 0.1 \text{ V}$ Max	$1.5 \pm 0.1 \text{ V}$ Max	$1.8 \pm 0.15 \text{ V}$ Max	$2.5 \pm 0.2 \text{ V}$ Max	$3.3 \pm 0.3 \text{ V}$ Max	
Propagation delay time (A → B)	t_{PLH}/t_{PHL}	22.0	15.1	9.8	7.0	5.5	4.9	4.3	4.2	ns
Propagation delay time (B → A)		25.3	16.5	10.9	7.9	6.3	5.5	4.3	3.8	
3-state output disable time ($\overline{OE} \rightarrow A$)	t_{PLZ}/t_{PHZ}	5.4	5.4	5.4	5.2	5.2	5.2	5.2	5.2	
3-state output disable time ($\overline{OE} \rightarrow B$)		34.0	24.6	18.7	12.6	8.9	7.3	5.6	4.7	
3-state output enable time ($\overline{OE} \rightarrow A$)	t_{PZL}/t_{PZH}	8.1	7.7	7.4	7.2	7.0	6.9	6.9	7.0	
3-state output enable time ($\overline{OE} \rightarrow B$)		97.3	63.4	38.3	24.5	16.8	13.4	9.6	8.0	

Note: See Figure 12.1, 13.1, 13.2, table 12.1.1, 12.1.2, 13.1.1 for the measurement circuit.

11.20. AC Characteristics (Note) ($V_{CCA} = 3.3 \pm 0.3 \text{ V}$, $T_a = -40 \text{ to } 125 \text{ }^\circ\text{C}$)

Characteristics	Symbol	V_{CCB}	V_{CCB}	V_{CCB}	V_{CCB}	V_{CCB}	V_{CCB}	V_{CCB}	V_{CCB}	Unit
		0.7 V Max	$0.8 \pm 0.04 \text{ V}$ Max	$0.9 \pm 0.045 \text{ V}$ Max	$1.2 \pm 0.1 \text{ V}$ Max	$1.5 \pm 0.1 \text{ V}$ Max	$1.8 \pm 0.15 \text{ V}$ Max	$2.5 \pm 0.2 \text{ V}$ Max	$3.3 \pm 0.3 \text{ V}$ Max	
Propagation delay time (A → B)	t_{PLH}/t_{PHL}	21.7	14.9	9.5	6.7	5.2	4.6	3.8	3.6	ns
Propagation delay time (B → A)		31.2	17.8	11.0	7.6	5.8	5.1	4.2	3.6	
3-state output disable time ($\overline{OE} \rightarrow A$)	t_{PLZ}/t_{PHZ}	5.4	5.4	5.4	5.2	5.2	5.2	5.2	5.2	
3-state output disable time ($\overline{OE} \rightarrow B$)		34.6	24.2	18.6	16.3	11.8	9.6	6.7	5.5	
3-state output enable time ($\overline{OE} \rightarrow A$)	t_{PZL}/t_{PZH}	7.5	6.8	6.5	6.3	5.7	5.6	5.6	5.6	
3-state output enable time ($\overline{OE} \rightarrow B$)		98.5	64.0	38.5	24.5	16.5	13.0	9.2	7.6	

Note: See Figure 12.1, 13.1, 13.2, table 12.1.1, 12.1.2, 13.1.1 for the measurement circuit.

11.21. Capacitive Characteristics (Unless otherwise specified, $T_a = 25 \text{ }^\circ\text{C}$)

Characteristics	Symbol	Note	Test Condition	$V_{CCA},$	$V_{CCA},$	$V_{CCA},$	$V_{CCA},$	$V_{CCA},$	$V_{CCA},$	$V_{CCA},$	$V_{CCA},$	Unit
				V_{CCB} 0.7 V Typ.	V_{CCB} 0.8 V Typ.	V_{CCB} 0.9 V Typ.	V_{CCB} 1.2 V Typ.	V_{CCB} 1.5 V Typ.	V_{CCB} 1.8 V Typ.	V_{CCB} 2.5 V Typ.	V_{CCB} 3.3 V Typ.	
Input capacitance	C_{IN}		$V_{IN} = 0 \text{ V or } 3.3 \text{ V}$	—	—	—	—	—	—	—	4	pF
Bus I/O capacitance	C_{IOA}		$A_n = \text{OFF},$ $V_{IOA} = 0 \text{ V or } 3.3 \text{ V}$	—	—	—	—	—	—	—	5	pF
	C_{IOB}		$B_n = \text{OFF},$ $V_{IOB} = 0 \text{ V or } 3.3 \text{ V}$	—	—	—	—	—	—	—	5	
Power dissipation capacitance	C_{PDA}	(Note 1)	A → B	1.5	1.5	1.5	1.5	2	2	2	2.5	pF
			B → A	13	13	13	13.5	13.5	14	14.5	15	
	C_{PDB}	(Note 1)	A → B	13	13	13	13.5	13.5	14	14.5	15	
			B → A	1.5	1.5	1.5	1.5	2	2	2	2.5	

Note 1: C_{PD} is defined as the value of the internal equivalent capacitance which is calculated from the operating current consumption without load. Average operating current can be obtained by the equation.

$$I_{CC(opr)} = C_{PD} \times V_{CC} \times f_{IN} + I_{CC}/4 \text{ (per bit)}$$

12. AC Test Circuit

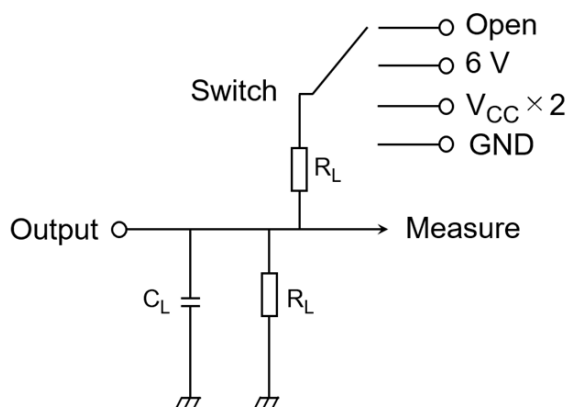

Fig. 12.1 AC Test Circuit

Table 12.1.1 Parameter for AC Test Circuit

Parameter	Switch
t_{PLH} , t_{PHL}	Open
t_{PLZ} , t_{PZL}	$V_{CC} \times 2$
t_{PHZ} , t_{PZH}	GND

Table 12.1.2 Parameter for AC Test Circuit

Symbol	$V_{CC} = 3.3 \pm 0.3$ V	$V_{CC} = 2.5 \pm 0.2$ V	$V_{CC} = 1.8 \pm 0.15$ V	$V_{CC} = 1.5 \pm 0.1$ V	$V_{CC} = 1.2 \pm 0.1$ V	$V_{CC} = 0.9 \pm 0.045$ V	$V_{CC} = 0.8 \pm 0.04$ V	$V_{CC} = 0.7$ V
R_L	2 k Ω	2 k Ω	2 k Ω	2 k Ω	2 k Ω	10 k Ω	10 k Ω	10 k Ω
C_L	15 pF	15 pF	15 pF	15 pF	15 pF	5 pF	5 pF	5 pF

13. AC Waveform

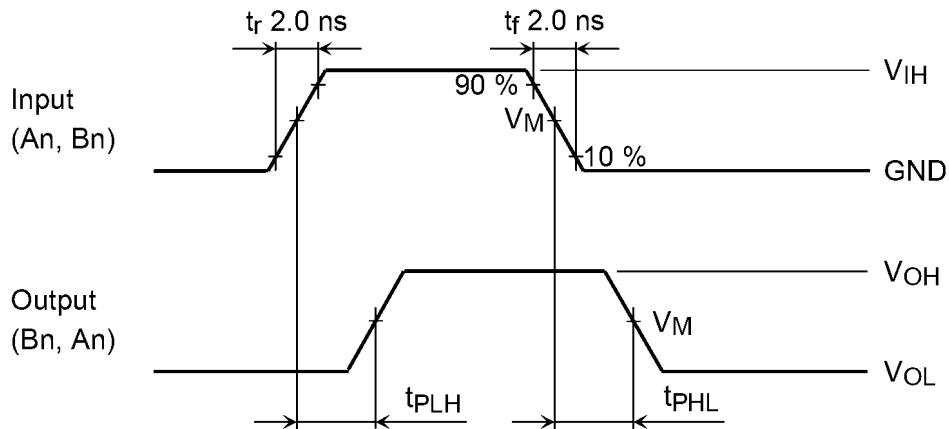

Fig. 13.1 t_{PLH} , t_{PHL}

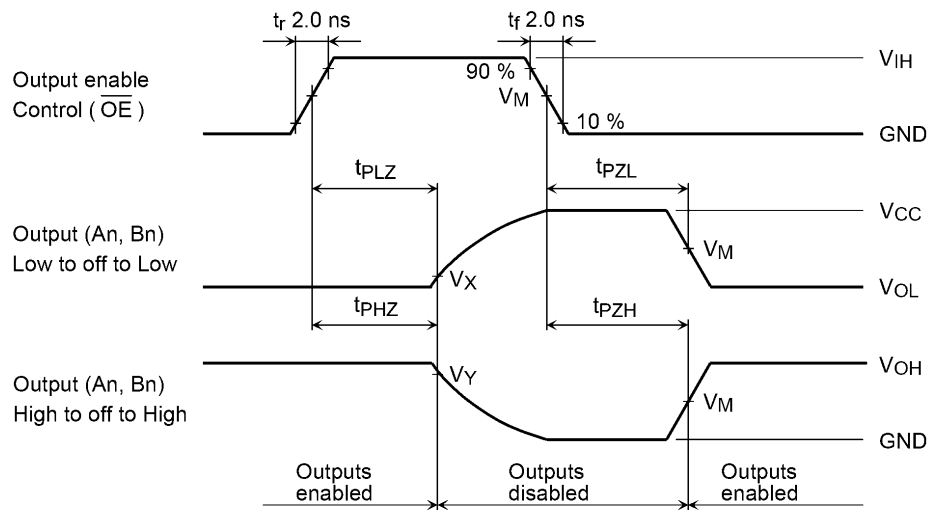

Fig. 13.2 t_{PLZ} , t_{PHZ} , t_{PZL} , t_{PZH}

Table 13.1.1 AC Waveform Symbols

Symbol	$V_{CC} = 3.3 \pm 0.3 \text{ V}$	$V_{CC} = 2.5 \pm 0.2 \text{ V}$ $V_{CC} = 1.8 \pm 0.15 \text{ V}$	$V_{CC} = 1.5 \pm 0.1 \text{ V}$ $V_{CC} = 1.2 \pm 0.1 \text{ V}$	$V_{CC} = 0.9 \pm 0.045 \text{ V}$ $V_{CC} = 0.8 \pm 0.04 \text{ V}$ $V_{CC} = 0.7 \text{ V}$
V_{IH}	V_{CC}	V_{CC}	V_{CC}	V_{CC}
V_M	$V_{CC}/2$	$V_{CC}/2$	$V_{CC}/2$	$V_{CC}/2$
V_X	$V_{OL} + 0.3 \text{ V}$	$V_{OL} + 0.15 \text{ V}$	$V_{OL} + 0.1 \text{ V}$	$V_{OL} + 0.1 \text{ V}$
V_Y	$V_{OH} - 0.3 \text{ V}$	$V_{OH} - 0.15 \text{ V}$	$V_{OH} - 0.1 \text{ V}$	$V_{OH} - 0.1 \text{ V}$

Package Dimensions

Unit: mm

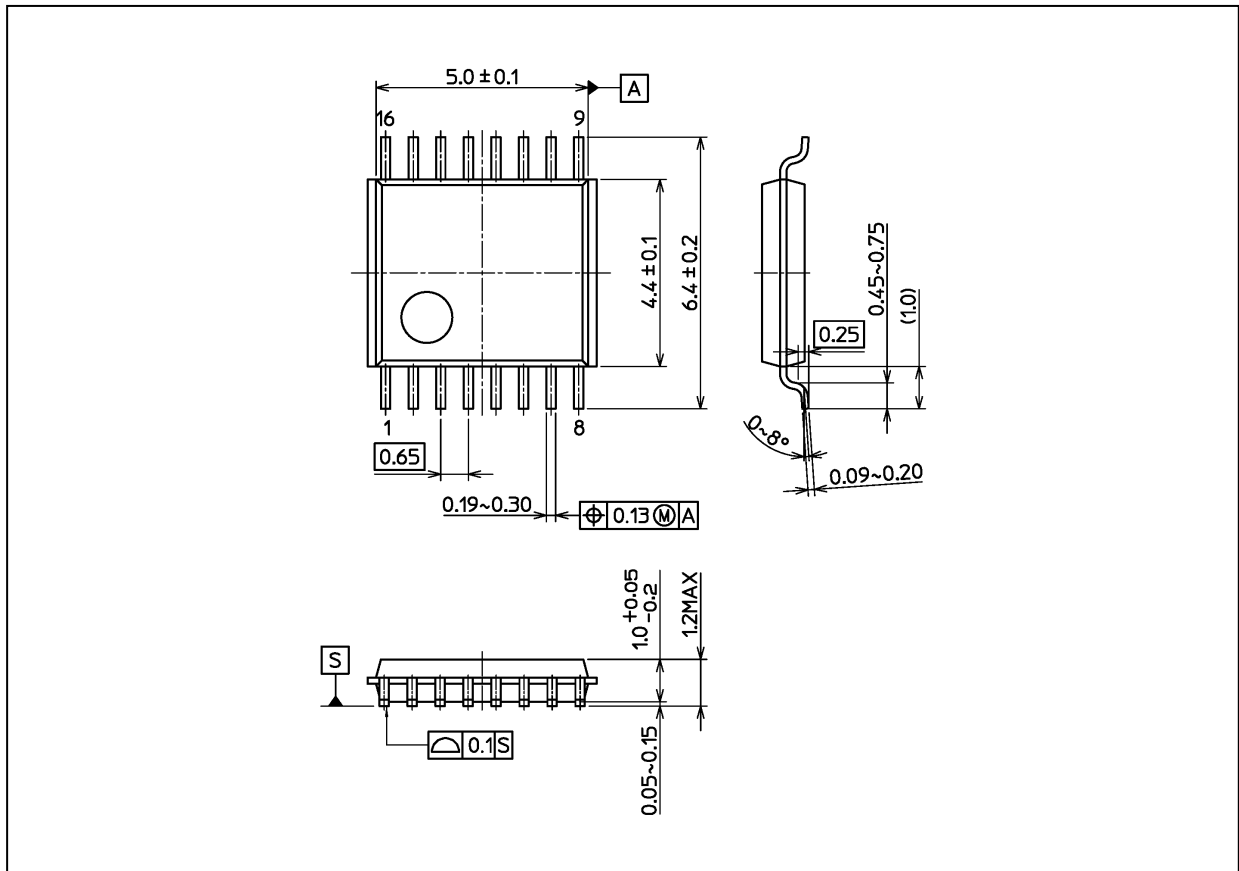

Weight: 0.055 g (typ.)

Package Name(s)
Nickname: TSSOP16B

RESTRICTIONS ON PRODUCT USE

Toshiba Corporation and its subsidiaries and affiliates are collectively referred to as "TOSHIBA".

Hardware, software and systems described in this document are collectively referred to as "Product".

- TOSHIBA reserves the right to make changes to the information in this document and related Product without notice.
- This document and any information herein may not be reproduced without prior written permission from TOSHIBA. Even with TOSHIBA's written permission, reproduction is permissible only if reproduction is without alteration/omission.
- Though TOSHIBA works continually to improve Product's quality and reliability, Product can malfunction or fail. Customers are responsible for complying with safety standards and for providing adequate designs and safeguards for their hardware, software and systems which minimize risk and avoid situations in which a malfunction or failure of Product could cause loss of human life, bodily injury or damage to property, including data loss or corruption. Before customers use the Product, create designs including the Product, or incorporate the Product into their own applications, customers must also refer to and comply with (a) the latest versions of all relevant TOSHIBA information, including without limitation, this document, the specifications, the data sheets and application notes for Product and the precautions and conditions set forth in the "TOSHIBA Semiconductor Reliability Handbook" and (b) the instructions for the application with which the Product will be used with or for. Customers are solely responsible for all aspects of their own product design or applications, including but not limited to (a) determining the appropriateness of the use of this Product in such design or applications; (b) evaluating and determining the applicability of any information contained in this document, or in charts, diagrams, programs, algorithms, sample application circuits, or any other referenced documents; and (c) validating all operating parameters for such designs and applications. **TOSHIBA ASSUMES NO LIABILITY FOR CUSTOMERS' PRODUCT DESIGN OR APPLICATIONS.**
- **PRODUCT IS NEITHER INTENDED NOR WARRANTED FOR USE IN EQUIPMENTS OR SYSTEMS THAT REQUIRE EXTRAORDINARILY HIGH LEVELS OF QUALITY AND/OR RELIABILITY, AND/OR A MALFUNCTION OR FAILURE OF WHICH MAY CAUSE LOSS OF HUMAN LIFE, BODILY INJURY, SERIOUS PROPERTY DAMAGE AND/OR SERIOUS PUBLIC IMPACT ("UNINTENDED USE").** Except for specific applications as expressly stated in this document, Unintended Use includes, without limitation, equipment used in nuclear facilities, equipment used in the aerospace industry, Class 3 medical devices, equipment used for automobiles, and military vehicles and munitions. **IF YOU USE PRODUCT FOR UNINTENDED USE, TOSHIBA ASSUMES NO LIABILITY FOR PRODUCT.** For details, please contact your TOSHIBA sales representative or contact us via our website.
- Do not disassemble, analyze, reverse-engineer, alter, modify, translate or copy Product, whether in whole or in part.
- Product shall not be used for or incorporated into any products or systems whose manufacture, use, or sale is prohibited under any applicable laws or regulations.
- The information contained herein is presented only as guidance for Product use. No responsibility is assumed by TOSHIBA for any infringement of patents or any other intellectual property rights of third parties that may result from the use of Product. No license to any intellectual property right is granted by this document, whether express or implied, by estoppel or otherwise.
- **ABSENT A WRITTEN SIGNED AGREEMENT, EXCEPT AS PROVIDED IN THE RELEVANT TERMS AND CONDITIONS OF SALE FOR PRODUCT, AND TO THE MAXIMUM EXTENT ALLOWABLE BY LAW, TOSHIBA (1) ASSUMES NO LIABILITY WHATSOEVER, INCLUDING WITHOUT LIMITATION, INDIRECT, CONSEQUENTIAL, SPECIAL, OR INCIDENTAL DAMAGES OR LOSS, INCLUDING WITHOUT LIMITATION, LOSS OF PROFITS, LOSS OF OPPORTUNITIES, BUSINESS INTERRUPTION AND LOSS OF DATA, AND (2) DISCLAIMS ANY AND ALL EXPRESS OR IMPLIED WARRANTIES AND CONDITIONS RELATED TO SALE, USE OF PRODUCT, OR INFORMATION, INCLUDING WARRANTIES OR CONDITIONS OF MERCHANTABILITY, FITNESS FOR A PARTICULAR PURPOSE, ACCURACY OF INFORMATION, OR NONINFRINGEMENT.**
- Do not use or otherwise make available Product or related software or technology for any military purposes, including without limitation, for the design, development, use, stockpiling or manufacturing of nuclear, chemical, or biological weapons or missile technology products (mass destruction weapons). Product and related software and technology may be controlled under the applicable export laws and regulations including, without limitation, the Japanese Foreign Exchange and Foreign Trade Law and the U.S. Export Administration Regulations. Export and re-export of Product or related software or technology are strictly prohibited except in compliance with all applicable export laws and regulations.
- Please contact your TOSHIBA sales representative for details as to environmental matters such as the RoHS compatibility of Product. Please use Product in compliance with all applicable laws and regulations that regulate the inclusion or use of controlled substances, including without limitation, the EU RoHS Directive. **TOSHIBA ASSUMES NO LIABILITY FOR DAMAGES OR LOSSES OCCURRING AS A RESULT OF NONCOMPLIANCE WITH APPLICABLE LAWS AND REGULATIONS.**