

TOSHIBA BiCD Integrated Circuit Silicon Monolithic

# TB67H482FNG

BiCD Constant Current Single H-bridge Driver IC

## 1. Description

TB67H482FNG is a Single H-bridge driver IC for driving brushed motor. Fabricated with the BiCD process, output rating is 50 V/5 A. The built-in regulator for IC operation allows the motor to be driven by a single VM power supply.

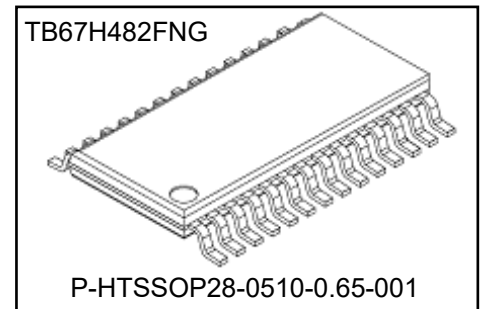

Weight: 105 mg (typ.)

## 2. Applications

Power IC developed for DC brushed motor applications.

## 3. Features

- BiCD process integrated monolithic IC
- Built-in H-bridge for output.
- Decay modes select function (Slow Decay / Fast Decay)
- Power saving function (Sleep mode)
- PWM constant current drive
- 3.3 V regulator output
- BiCD structure: DMOSFET is used for output power transistor
- High breakdown voltage, large current: 50 V / 5 A (absolute maximum rating)
- Thermal shutdown detection (TSD), overcurrent detection (ISD), and low power supply voltage detection (UVLO)
- Error detection flag output function (LO).
- Reduction of external parts for charge pump
- Package: P-HTSSOP28-0510-0.65-001

Start of commercial production  
2025-01

**4. Block Diagram**

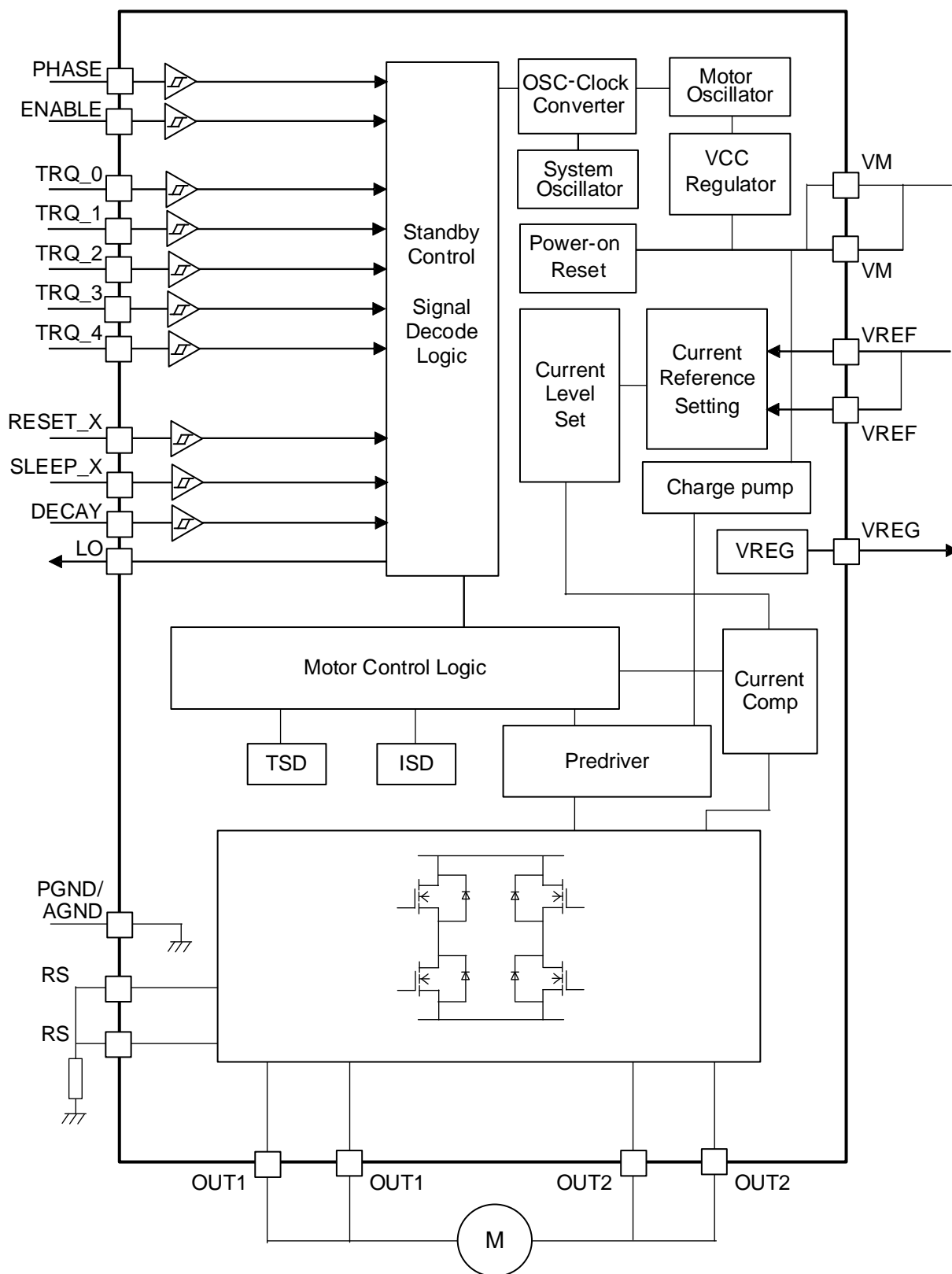
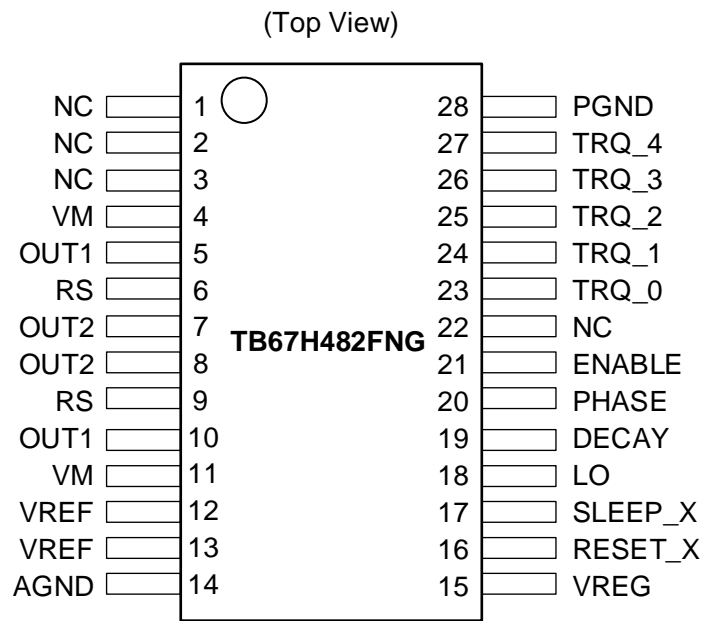

**Figure 4 Block Diagram**

Note: Some of the functional blocks, circuits, or constants in the block diagram may be omitted or simplified for explanatory purpose.

Note: All the grounding wires should be solid patterns and be externally terminated at only one point. Also, a grounding method should be considered for efficient heat dissipation. Careful attention should be paid to the layout of the output, VM and GND traces, to avoid short circuits across output pins or to the power supply or ground. If such a short circuit occurs, the device may be permanently damaged. Also, the utmost care should be taken for pattern designing and implementation of the device since it has power supply pins (VM, OUT1, OUT2, PGND and AGND) through which a particularly large current may run. If these pins are wired incorrectly, an operation error may occur or the device may be destroyed. The logic input pins must also be wired correctly. Otherwise, the device may be damaged owing to a current running through the IC that is larger than the specified current. Careful attention should be paid to design patterns and mounting.

**5. Pin Assignments**



**Figure 5 Pin Assignments**

## 6. Pin Description

**Table 6.1 Pin Description**

Pin No.	Symbol	Description
1	NC	NC pin
2	NC	NC pin
3	NC	NC pin
4	VM	Motor power supply input pin (HSW)
5	OUT1	Motor output pin 1
6	RS	Current sense resistor connected pin
7	OUT2	Motor output pin 2
8	OUT2	Motor output pin 2
9	RS	Current sense resistor connected pin
10	OUT1	Motor output pin 1
11	VM	Motor power supply input pin (HSW)
12	VREF	Current threshold reference pin
13	VREF	Current threshold reference pin
14	AGND	GND pin
15	VREG	3.3 V regulator output pin
16	RESET_X	Reset input pin
17	SLEEP_X	Sleep mode input pin
18	LO	Error output pin
19	DECAY	Decay mode select pin
20	PHASE	PHASE input pin for motor
21	ENABLE	Enable input pin for motor
22	NC	NC pin
23	TRQ_0	Motor Ach torque setting pin
24	TRQ_1	Motor Ach torque setting pin
25	TRQ_2	Motor Ach torque setting pin
26	TRQ_3	Motor Ach torque setting pin
27	TRQ_4	Motor Ach torque setting pin
28	PGND	GND pin

Note: NC pin should be opened.

There are two pins each for VM, OUT1, OUT2, RS and VREF, each of which should be used in Short.

**7. Input / Output Equivalent Circuit**

**Table 7 Input / Output Equivalent Circuit**

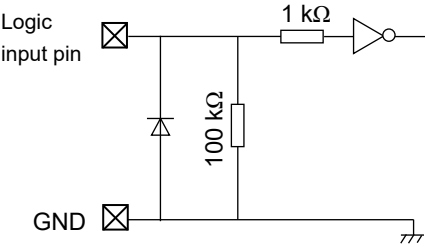
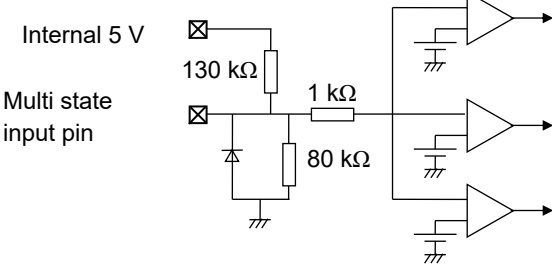
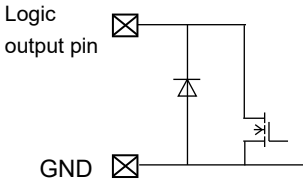
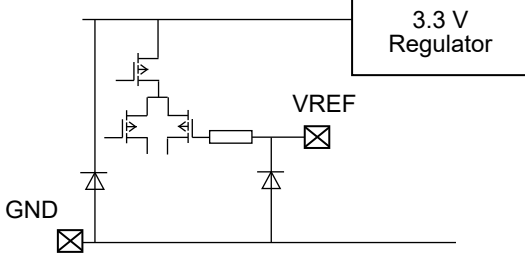
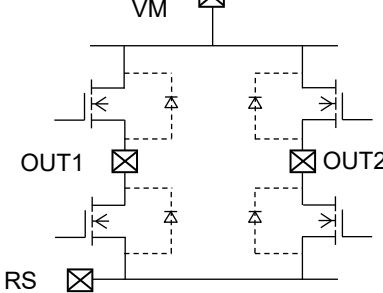
Pin name	Equivalent circuit
TRQ_0 TRQ_1 TRQ_2 TRQ_3 TRQ_4 PHASE ENABLE SLEEP_X RESET_X	
DECAY	
LO	
VREF	
VM OUT1 OUT2 RS	

Note: The equivalent circuit diagrams may be simplified for explanatory purposes.

## 8. Operation Description

### 8.1. Input / Output Function

**Table 8.1 Input / Output Function**

DECAY	ENABLE	PHASE	OUT1	OUT2
L	L	—	L	L
H	L	—	Z	Z
—	H	H	H	L
—	H	L	L	H

Note: For the current path, OUT1 → OUT2 is forward rotation and OUT2 → OUT1 is reverse rotation.  
 '—' are don't care .

### 8.2. LO (Error output) Function

LO pin is an Nch MOS output open drain terminal. When using this function, pull up the LO pin to the  $V_{IN(H)}$  level. Normally, it is Hi-Z (internal MOS is OFF), and when the error detection function (overheat (TSD), overcurrent (ISD)) is activated, the pin level is L (internal MOSFET is ON).  
 If the error detection is released by turning the VM power supply on again or resetting, the LO pin will return to normal (the internal MOS is off) again.  
 If the LO pin is not used, leave it open.

**Table 8.2 LO (Error output) Function**

LO	Function
H	Normal state (normal operation)
L	Error condition detected (ISD, TSD)

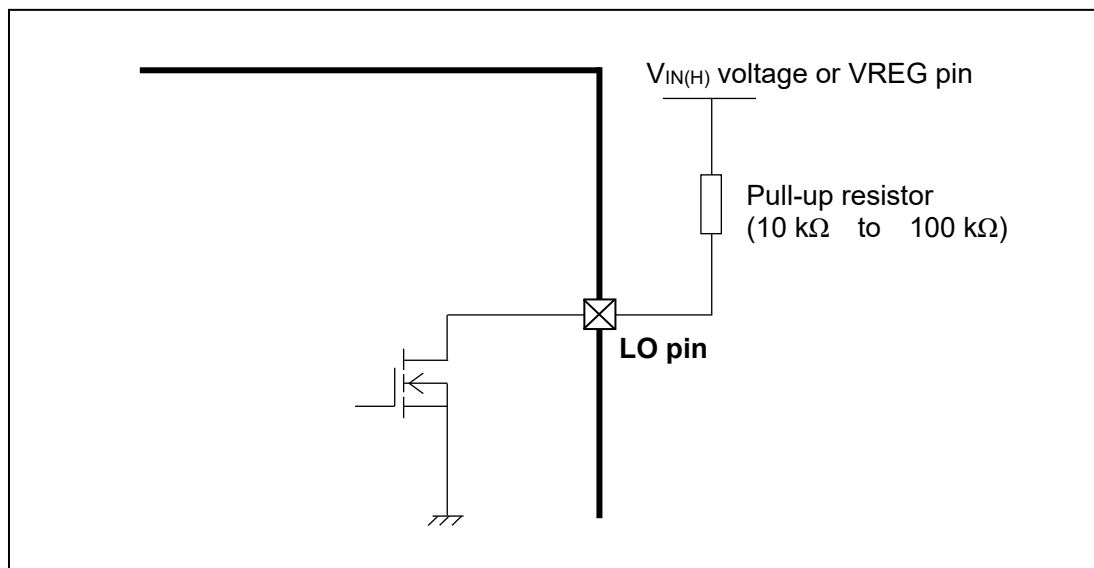

**Figure 8.2 LO pin equivalent circuit diagram**

Note: This figure may be simplified for explanatory purpose.

### 8.3. Constant Current Control

TB67H482FNG has a current limit function that monitors the current flowing in the motor and performs constant current PWM control. When the motor current reaches the set current value (I<sub>out(maximum)</sub>), it shifts to Decay mode and attenuates the current.

The setting current value is determined by the VREF pin voltage and the current detection resistance value. Also, the setting current value can be adjusted with the torque function. When high torque is not needed, the motor current can be suppressed by lowering the torque setting.

To disable the constant current control function, connect the RSA and RSB terminals to GND and the VREFA and VREFB, terminals to VREG.

### 8.4. Torque Function

TRQ\_x pins set the torque of the motor. (x=0,1,2,3,4)

**Table 8.4 Torque Function**

TRQ_4	TRQ_3	TRQ_2	TRQ_1	TRQ_0	Function
L	L	L	L	L	Torque: 0 % (Bridge disabled)
L	L	L	L	H	Torque: 5 %
L	L	L	H	L	Torque: 10 %
L	L	L	H	H	Torque: 15 %
L	L	H	L	L	Torque: 20 %
L	L	H	L	H	Torque: 24 %
L	L	H	H	L	Torque: 29 %
L	L	H	H	H	Torque: 34 %
L	H	L	L	L	Torque: 38 %
L	H	L	L	H	Torque: 43 %
L	H	L	H	L	Torque: 47 %
L	H	L	H	H	Torque: 51 %
L	H	H	L	L	Torque: 56 %
L	H	H	L	H	Torque: 60 %
L	H	H	H	L	Torque: 63 %
L	H	H	H	H	Torque: 67 %
H	L	L	L	L	Torque: 71 %
H	L	L	L	H	Torque: 74 %
H	L	L	H	L	Torque: 77 %
H	L	L	H	H	Torque: 80 %
H	L	H	L	L	Torque: 83 %
H	L	H	L	H	Torque: 86 %
H	L	H	H	L	Torque: 88 %
H	L	H	H	H	Torque: 90 %
H	H	L	L	L	Torque: 92 %
H	H	L	L	H	Torque: 94 %
H	H	L	H	L	Torque: 96 %
H	H	L	H	H	Torque: 97 %
H	H	H	L	L	Torque: 98 %
H	H	H	L	H	Torque: 99 %
H	H	H	H	L	Torque: 100 %
H	H	H	H	H	Torque: 100 %



## 8.5. About the Constant Current Value

The constant current PWM threshold ( $I_{OUT (MAX)}$ ) can be set via the current-sensing resistor ( $R_{RS}$ ) and the reference voltage ( $V_{REF}$ )

$$I_{OUT (MAX)} = \frac{V_{REF (V)}}{V_{REF(GAIN)} \times R_{RS} (\Omega)} \times \text{Torque}(\%)$$

$V_{REF(GAIN)}$ :  $V_{REF}$  decay ratio is 5 (typ.).

Example:  $V_{REF} = 3.3 \text{ V}$ ,  $R_{RS} = 0.22 \text{ } \Omega$ , Torque: 100 %  
 $I_{OUT (MAX)} = 3 \text{ A}$ .

Note: It is recommended to use  $V_{REF}$  in the range of 1 to 3.6 V.  
 If a  $V_{REF}$  of 4.5 V or more is applied, the device will enter test mode.

## 8.6. DECAY Function (DECAY)

Decay model can be selected during constant current control.

**Table 8.6 DECAY Function**

DECAY	Function
L	Slow decay mode
H	Fast decay mode

## 8.7. Constant Current PWM Blanking Time

TB67H482FNG is provided with the following blanking time as a measure against spike current generated during motor operation and noise jump from the outside.

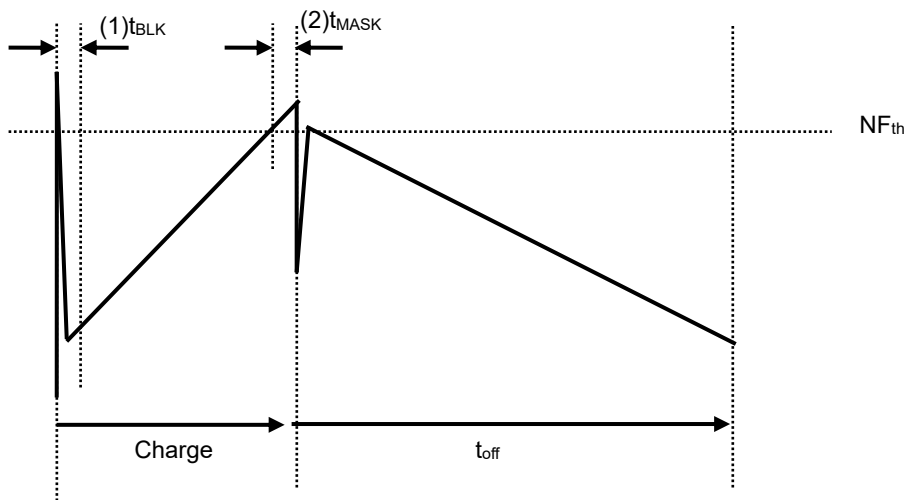

**Figure 8.7 Constant Current PWM Timing Chart**

Note: (1)  $t_{BLK}$  for preventing false detection of spike current generated during Decay→Charge:  
 3.75  $\mu\text{s}$ (typ.)

(2)  $t_{MASK}$ (Current-through (mask) time for preventing false detection of noise)

Note: Timing charts may be simplified for explanatory purposes.

**8.8. Input Signal and Blanking Time of  $t_{BLK}$**

The blanking time  $t_{BLK}$  is set in consideration of the influence of the inrush current that originally occurs at the timing of switching from Decay to Charge. With the TB67H482FNG, not only constant current PWM control but also motor drive by direct PWM control, which controls the PHASE input signal by switching at arbitrary timing, is assumed, so at each PHASE input signal switching timing (gray in the timing chart below)  $t_{BLK}$  is generated in the hatched area.

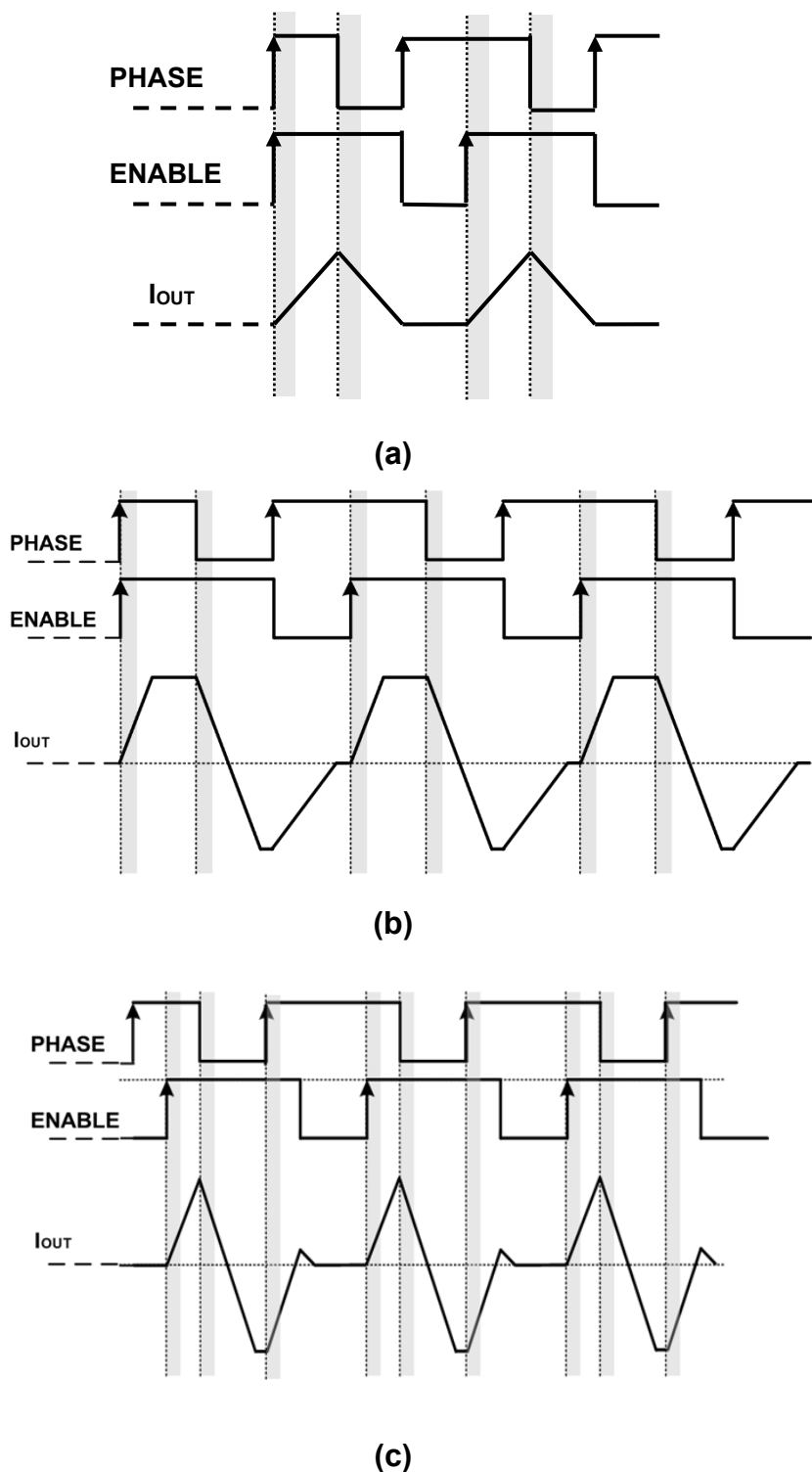

**Figure 8.8 Input Signal and Blanking Time of  $t_{BLK}$  Timing Charts**

Note: Timing charts may be simplified for explanatory purposes.

**8.9. SLEEP\_X Function**

The SLEEP\_X pin switches between normal operation mode and sleep mode. In Sleep mode, the VREG output, internal oscillator circuit and motor output section are disabled, while the unit enters a low-power consumption state. In this state, the internal circuits are also initialised. A maximum wake-up time of 10 ms (*t<sub>WAKE</sub>*) is required when returning to normal operation mode from Sleep mode.

**Table 8.9 SLEEP\_X Function**

SLEEP_X	Function
L	Sleep mode
H	Normal operation mode

Note: If SLEEP\_X is set to L, the TSD and ISD detection states will be reset.

**8.10. RESET\_X Function**

The RESET\_X pin switches between normal mode and reset state. When the fault detection function (ISD, TSD) is activated, all FETs in the H-bridge are switched off and the level of the LO pin is set to L. By setting the RESET\_X pin to L, the ISD detection stat will be reset.

**Table 8.10 RESET\_X Function**

RESET_X	Function
L	Reset (internal Logic clear)
H	Normal operation mode

Note: If RESET\_X is set to L, the TSD detection state will NOT be reset.

## 9. Operation Mode of Output Transistor

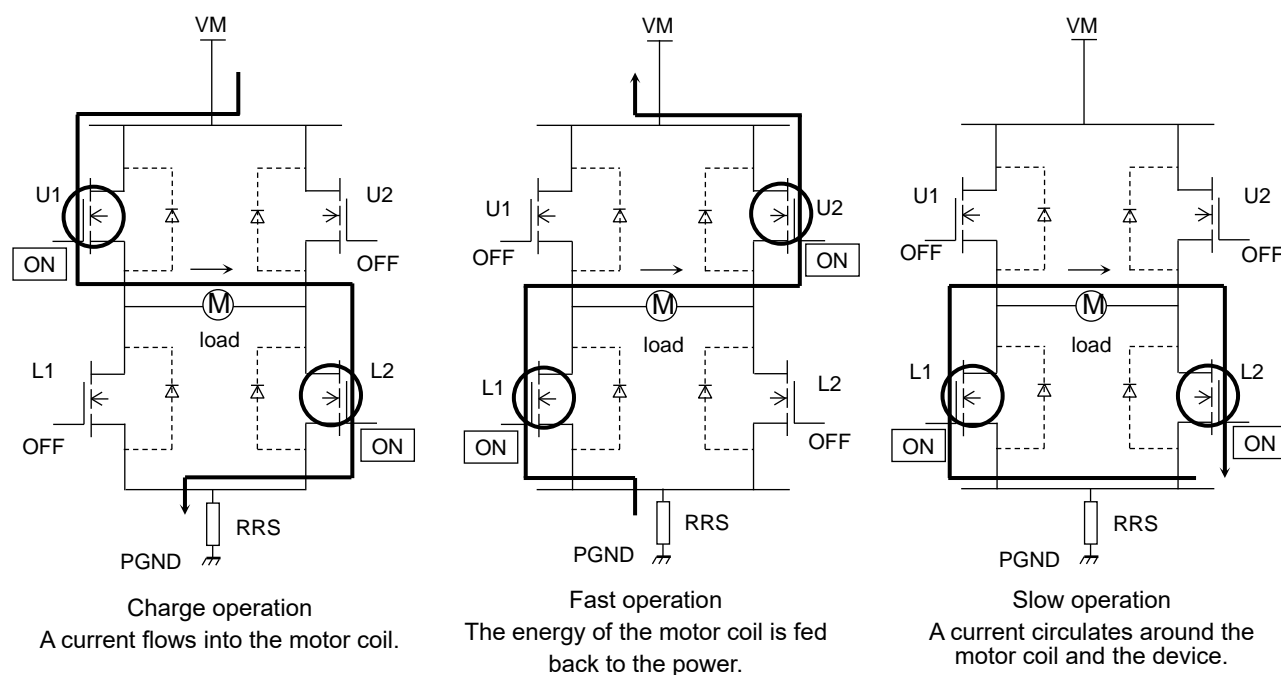

**Figure 8.1 Operation Mode of Output Transistor (Positive Current)**

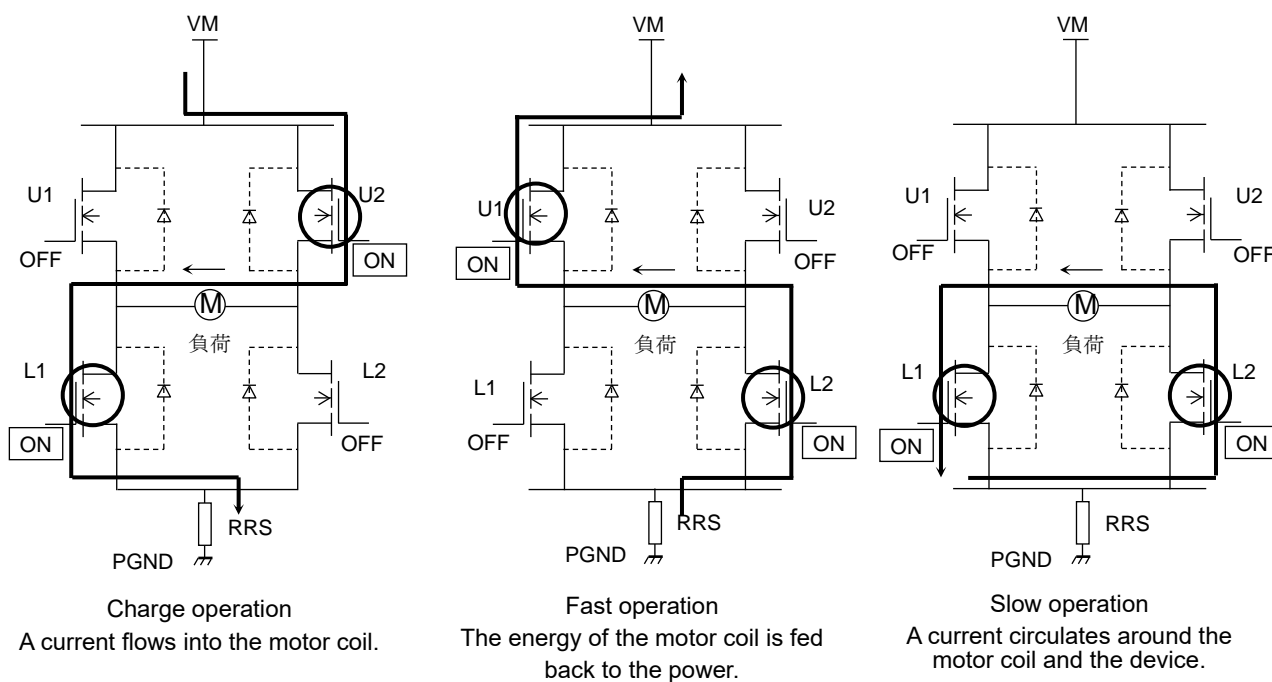

**Figure 8.2 Operation Mode of Output Transistor (Negative Current)**

Note: In the timing of an output switching, the time to prevent a through current is predefined.

**9.1. Operation Function of Output Transistor****Table 9.1.1 At Positive Current**

Mode	U1	U2	L1	L2
CHARGE	ON	OFF	OFF	ON
FAST	OFF	ON	ON	OFF
SLOW	OFF	OFF	ON	ON

Note: The parameters shown in the table above are examples when the current flows in the directions shown in the figures above. For the current flowing in the reverse direction, the parameters are shown below.

**Table 9.1.2 At Negative Current**

Mode	U1	U2	L1	L2
CHARGE	OFF	ON	ON	OFF
FAST	ON	OFF	OFF	ON
SLOW	OFF	OFF	ON	ON

Note: This IC controls the motor current to be constant by 3 modes listed above. The equivalent circuit diagrams may be simplified or some parts of them may be omitted for explanatory purposes.

## 10. Power Consumption of the IC

Power consumption of the IC is consumed by the transistor of the output block and that of the logic block mainly.

### 10.1. Power Consumption of the Power Transistor

Power of the output block is consumed by the upper and lower MOSFET of the H-Bridge. Power consumption of the upper or lower transistor of the H-Bridge is calculated from below formula.

$$P(\text{out}) = I_{\text{OUT}}(\text{A}) \times V_{\text{DS}}(\text{V}) = I_{\text{OUT}}(\text{A})^2 \times R_{\text{ON}}(\Omega) \dots \dots \dots (1)$$

When the current waveform of the motor output corresponds to the ideal square waveform in the full-step resolution, average power of output block can be provided as follows.

For example: when  $R_{\text{ON}} = 0.2 \Omega$ ,  $I_{\text{OUT}}(\text{peak: Max}) = 2.0 \text{ A}$ ,  $V_{\text{M}} = 24 \text{ V}$

$$P(\text{out}) = 2(\text{Tr}) \times 2.0(\text{A})^2 \times 0.2(\Omega) \dots \dots \dots (2)$$

$$= 1.6(\text{W})$$

### 10.2. Power Consumption of Logic and IM Systems

Power consumptions of logic and IM systems are calculated by separating the states (operating and standby).

$$I(I_{\text{M2}}) = 5 \text{ mA (typ.)} : \text{Operating/axis}$$

$$I(I_{\text{M1}}) = 1 \mu\text{A (max.)} : \text{Standby/axis}$$

Output system is connected to  $V_{\text{M}}$  (24 V). (Output system: Current consumed by the circuit connected to  $V_{\text{M}}$  + Current consumed by switching output steps)

Power consumption is calculated as follows;

$$P(I_{\text{M2}}) = 24(\text{V}) \times 0.005(\text{A}) \dots \dots \dots (3)$$

$$= 0.12(\text{W})$$

### 10.3. Power Consumption

Total power consumption  $P(\text{total})$  is calculated from the results of (1) and (2) above.

$$P(\text{total}) = P(\text{out}) + P(I_{\text{M2}}) = 1.72(\text{W})$$

Power consumption of 1 axle in standby mode is as follows:

$$P(\text{Standby mode}) = 24(\text{V}) \times 1(\mu\text{A}) = 24(\mu\text{W})$$

About the heat design of the board etc., please evaluate it by the actual board enough, and configure the appropriate margin.

## 11. Thermal Shutdown Detection

### (Auto Return Type)

This function turns off the IC operation temporarily when the over heat of the device is detected. It has a dead band time to avoid error detection occurred by the external noise. When over heat is detected, all channels are turned off.

Since the temperature has a hysteresis range, when the junction temperature falls to the return temperature, the operation returns automatically to the normal operation.

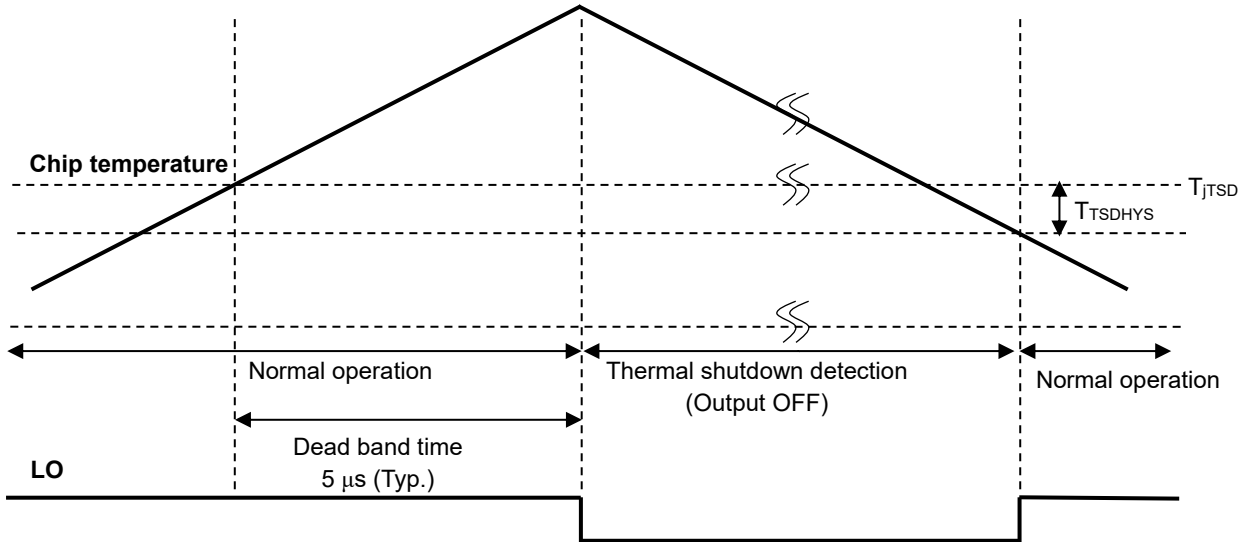

**Figure 10.1 Thermal Shutdown Detection Timing Chart 1**

Note: Timing charts may be simplified for explanatory purposes. The value in the timing chart is the reference value.

TSD function has a detection deadband time. When operating near the TSD detection threshold temperature, when the temperature of the IC falls below the TSD detection threshold immediately after the dead band time ends, normal operation is immediately performed and the LO signal is output momentarily (156 to 312 ns (Typ.)).

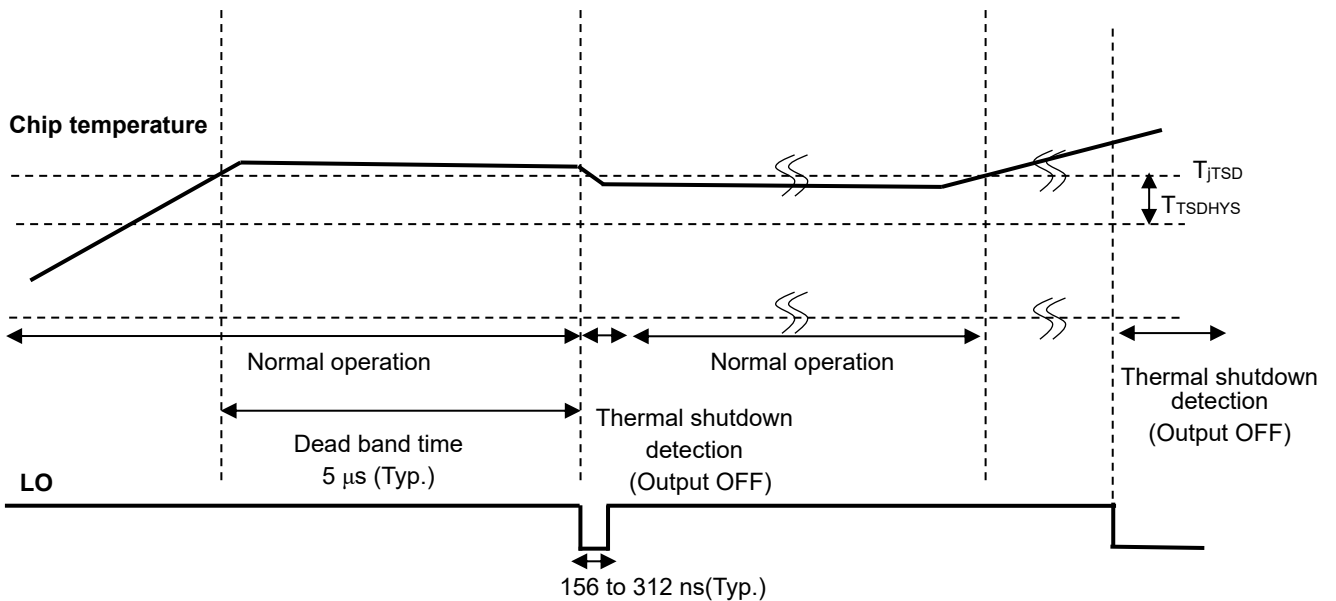

**Figure 10.2 Thermal Shutdown Detection Timing Chart 2**

Note: Timing charts may be simplified for explanatory purposes. The value in the timing chart is the reference value.

## 12. Over Current Detection

### (Latch Type: Operation State before Detection is Maintained)

This function turns off the IC operation temporarily when the short-circuiting between outputs and the short-circuiting to the power supply or ground occur.

It has a dead band time to avoid error detection occurred by the spike current which generates in switching and the external noise. When over current is detected, not only the corresponding channels but both channels are turned off.

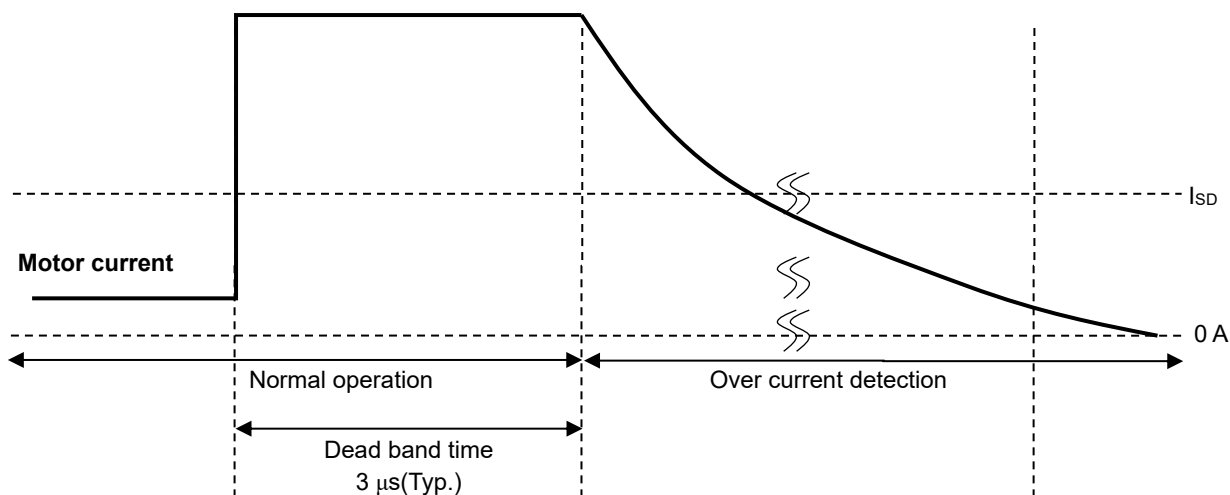

**Figure 12 Over Current Detection Timing Chart**

Note: Timing charts may be simplified for explanatory purposes. The value in the timing chart is the reference value.



## 13. Absolute Maximum Ratings

**Table 13 Absolute Maximum Ratings**

( $T_a = 25^\circ\text{C}$  unless otherwise specified)

Characteristics	Symbol	Rating	Unit
Motor output voltage	$V_{OUT}$	50	V
Motor power supply	$V_M$	45	V
Motor output current (Note1)	$I_{OUT}$	5	A
Logic input voltage	$V_{IN}$	6.0	V
$V_{REF}$ reference voltage	$V_{REF}$	6.0	V
LO output voltage	$V_{LO}$	6.0	V
Power dissipation (Note2)	$P_D$	4.0	W
Operating temperature	$T_{opr}$	-40 to 85	$^\circ\text{C}$
Storage temperature	$T_{stg}$	-55 to 150	$^\circ\text{C}$
Junction temperature	$T_j$	150	$^\circ\text{C}$

Note1: The maximum current value in normal operation should be kept 3.6 A or less per phase after calculating heat generation. The maximum output current may be further limited in view of the thermal considerations, depending on the ambient temperature and board conditions.

Note2: Based on JEDEC standard 4-layer PCB ( $T_a = 25^\circ\text{C}$ )

When  $T_a$  exceeds  $25^\circ\text{C}$ , derating with  $32\text{ mW} / ^\circ\text{C}$  is necessary.

$T_a$  : Ambient temperature of the IC

$T_{opr}$  : Ambient temperature while the IC is active.

$T_j$  : Junction temperature while the IC is active. The maximum junction temperature is limited by the thermal shutdown circuit (TSD).

It is advisable to keep the maximum current below a certain level so that the maximum junction temperature  $T_{j(MAX)}$  will not exceed  $120^\circ\text{C}$ .

### Absolute maximum ratings

The absolute maximum ratings of a semiconductor device are a set of ratings that must not be exceeded, even for a moment. Do not exceed any of these ratings.

Exceeding the rating(s) may cause device breakdown, damage or deterioration, and may result in injury by explosion or combustion. The value of even one parameter of the absolute maximum ratings should not be exceeded under any circumstances. The TB67H482FNG does not have overvoltage detection circuit. Therefore, the device is damaged if a voltage exceeding its rated maximum is applied. All voltage ratings, including supply voltages, must always be followed. The other notes and considerations described later should also be referred to.

## 14. Operating Range

Table 14 Operating Range

Characteristics	Symbol	Min	Typ.	Max	Unit	Remarks
Motor power supply	$V_M$	8.2	24.0	44	V	—
Motor output current	$I_{OUT}$	—	—	4.0	A	(Note)
Logic input voltage	$V_{IN(H)}$	2.2	—	5.25	V	Logic input High Level
	$V_{IN(L)}$	0	—	0.7	V	Logic input Low Level
Chopping frequency	$f_{CHOP}$	—	50	—	kHz	—
Clock frequency	$f_{logic}$	—	—	100	kHz	—
$V_{REF}$ reference voltage	$V_{REF}$	1	—	3.6	V	—
$V_{RS}$ detection voltage	$V_{RS}$	0.9	1.0	1.1	V	—

Note: The actual maximum current may be limited by the operating environment (operating conditions such as exciting mode and operating time, or by the surrounding temperature or board heat dissipation). Determine a realistic maximum current by calculating the heat generated under the operating environment.

## 15. Electrical Specifications

### 15.1. Electrical Specifications 1

**Table 15.1 Electrical Specifications 1**

( $V_M = 24\text{ V}$ ,  $T_a = 25^\circ\text{C}$  unless otherwise specified)

Characteristics		Symbol	Test condition	Min	Typ.	Max	Unit
Logic input voltage	High	$V_{IN(H)}$	Logic input pin (Note)	2.2	—	5.25	V
	Low	$V_{IN(L)}$	Logic input pin (Note)	0	—	0.7	V
DECAY input voltage	High	$V_{IN(H)DCY}$	DECAY input pin (Note)	2	—	(5.25)	V
	Low	$V_{IN(L)DCY}$	DECAY input pin (Note)	0	—	0.8	V
Logic input hysteresis voltage		$V_{IN(HIS)}$	Logic input pin (Note)	100	200	300	mV
Logic input current	High	$I_{IN(H)}$	Logic input voltage:3.3 V	—	33	100	$\mu\text{A}$
	Low	$I_{IN(L)}$	Logic input voltage:0 V	-20	—	20	$\mu\text{A}$
DECAY input current	High	$I_{INDCY(H)}$	DECAY input voltage:3.3 V	20	28	35	$\mu\text{A}$
	Low	$I_{INDCY(L)}$	DECAY input voltage:0 V	-45	-36	-25	$\mu\text{A}$
LO output voltage		$V_{OL(LO)}$	$I_{OL}=5\text{ mA}$ , Output: Low	—	0.2	0.5	V
LO pin leakage current		$I_{OL(LO)}$	$V_{O(LO)} = 3.3\text{ V}$	—	—	1	$\mu\text{A}$
Power consumption		$I_{M1}$	Output pin: Open, Sleep mode	—	—	1	$\mu\text{A}$
		$I_{M2}$	Output pin: Open, Operating mode ( $f_{logic} < 50\text{ kHz}$ )	—	5	8	mA
Output leakage current	High-side	$I_{OH}$	$V_M = 44\text{ V}$ , $V_{OUT} = 0\text{ V}$	—	—	2	$\mu\text{A}$
	Low-side	$I_{OL}$	$V_M = V_{OUT} = 44\text{ V}$	-2	—	—	$\mu\text{A}$
Motor current setting accuracy ( $V_{REF} = 3.3\text{ V}$ )		$\Delta I_{OUT}$	Torque: 5%	-25	0	25	%
			Torque: 10 to 34%	-15	0	15	%
			Torque: 38 to 67%	-10	0	10	%
			Torque: 71 to 100%	-5	0	5	%
Motor output ON-resistance (High-side + Low-side)		$R_{ON(D-S)}$	$T_j = 25^\circ\text{C}$ $I_{OUT} = 2.0\text{ A}$	—	0.2	0.26	$\Omega$

Note:  $V_{IN(H)}$  is defined as the  $V_{IN}$  voltage that changes the output voltage by being applied to the test pin and raising this voltage from 0 V gradually.  $V_{IN(L)}$  is defined as the  $V_{IN}$  voltage that changes the output voltage by being applied to the test pin and lowering this voltage gradually. The difference between  $V_{IN(H)}$  and  $V_{IN(L)}$  is defined as  $V_{IN(HYS)}$ .

## 15.2. Electrical Specifications 2

Table 15.2 Electrical Specifications 2

(V<sub>M</sub> = 24 V, T<sub>a</sub> = 25°C unless otherwise specified)

Characteristics	Symbol	Test condition	Min	Typ.	Max	Unit
V <sub>REF</sub> input current	I <sub>REF</sub>	V <sub>REF</sub> = 3.3 V	-3	—	3	μA
V <sub>REF</sub> input voltage	V <sub>REF</sub>	Normal operation	1	—	3.6	V
		Test mode (Note)	4.5	—	—	V
V <sub>REF</sub> decay ratio	V <sub>REF</sub> (GAIN)	V <sub>REF</sub> = 2.0 V	—	5	—	ratio
V <sub>REG</sub> voltage	V <sub>REG</sub>	I <sub>OUT</sub> = 1 mA	3.2	3.3	3.4	V
TSD threshold	T <sub>JTSD</sub>	—	150	160	180	°C
TSD hysteresis	T <sub>TSDHYS</sub>	—	—	30	—	°C
VM power ON reset voltage	V <sub>M POR</sub>	—	3.7	4.0	4.4	V
VM power ON reset hysteresis voltage	V <sub>M POR</sub> (HYS)	—	180	200	230	mV
Over current detection circuit operating current	I <sub>SD</sub>	—	6.0	—	—	A

Note: The test mode is set for use in product outgoing inspection.

The V<sub>REF</sub> input voltage must always be within the range of [Normal operation].

## 15.2.1. Back-EMF

While a motor is rotating, there is a timing at which power is fed back to the power supply. At that timing, the motor current recirculates back to the power supply due to the effect of the motor back-EMF.

If the power supply does not have enough sink capability, the power supply and output pins of the device might rise above the rated voltages. The magnitude of the motor back-EMF varies with usage conditions and motor characteristics. It must be fully verified that there is no risk that the TB67H480FNG or other components will be damaged or fail due to the motor back-EMF.

## 15.2.2. Cautions on Overcurrent Shutdown (ISD) and Thermal Shutdown (TSD)

The ISD and TSD circuits are only intended to provide temporary protection against irregular conditions such as an output short-circuit; they do not necessarily guarantee the complete IC safety.

If the device is used beyond the specified operating ranges, these circuits may not operate properly: then the device may be damaged due to an output short-circuit.

The ISD circuit is only intended to provide a temporary protection against an output short-circuit. If such a condition persists for a long time, the device may be damaged due to overstress. Overcurrent conditions must be removed immediately by external hardware.

## 15.2.3. IC Mounting

Do not insert devices incorrectly or in the wrong orientation. Otherwise, it may cause breakdown, damage and/or deterioration of the device.

## 16. AC Electrical Specifications

Table 16 AC Electrical Specification

( $V_M = 24\text{ V}$ ,  $T_a = 25^\circ\text{C}$  unless otherwise specified)

Characteristics	Symbol	Test condition	Min	Typ.	Max	Unit
Logic input pulse width	$t_{W(H)}$	—	1.9	—	—	$\mu\text{s}$
	$t_{W(L)}$	—	1.9	—	—	$\mu\text{s}$
Output transistor switching characteristics	$t_r$	—	30	—	200	ns
	$t_f$		30	—	200	ns
	$t_{pLH}$	—	440	—	ns	
	$t_{pHL}$	—	400	—	ns	
Wakeup time	$t_{WAKE}$	—	—	10	ms	
Chopping frequency	$f_{CHOP}$	—	50	—	kHz	
tBLANK time	$t_{BLK}$	—	—	3.75	$\mu\text{s}$	
Blanking time of noise rejection	$t_{DEG}$	—	—	3	$\mu\text{s}$	

### 16.1. AC Electrical Specification Timing Chart

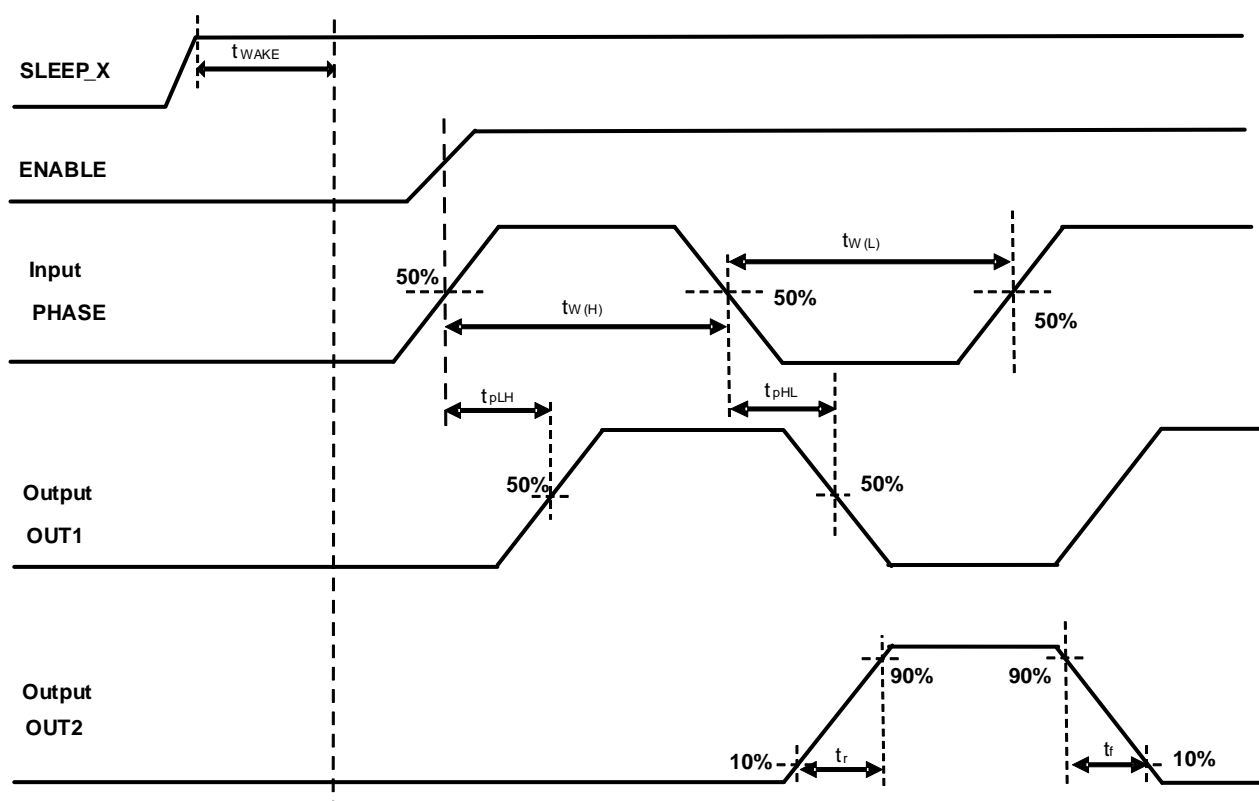
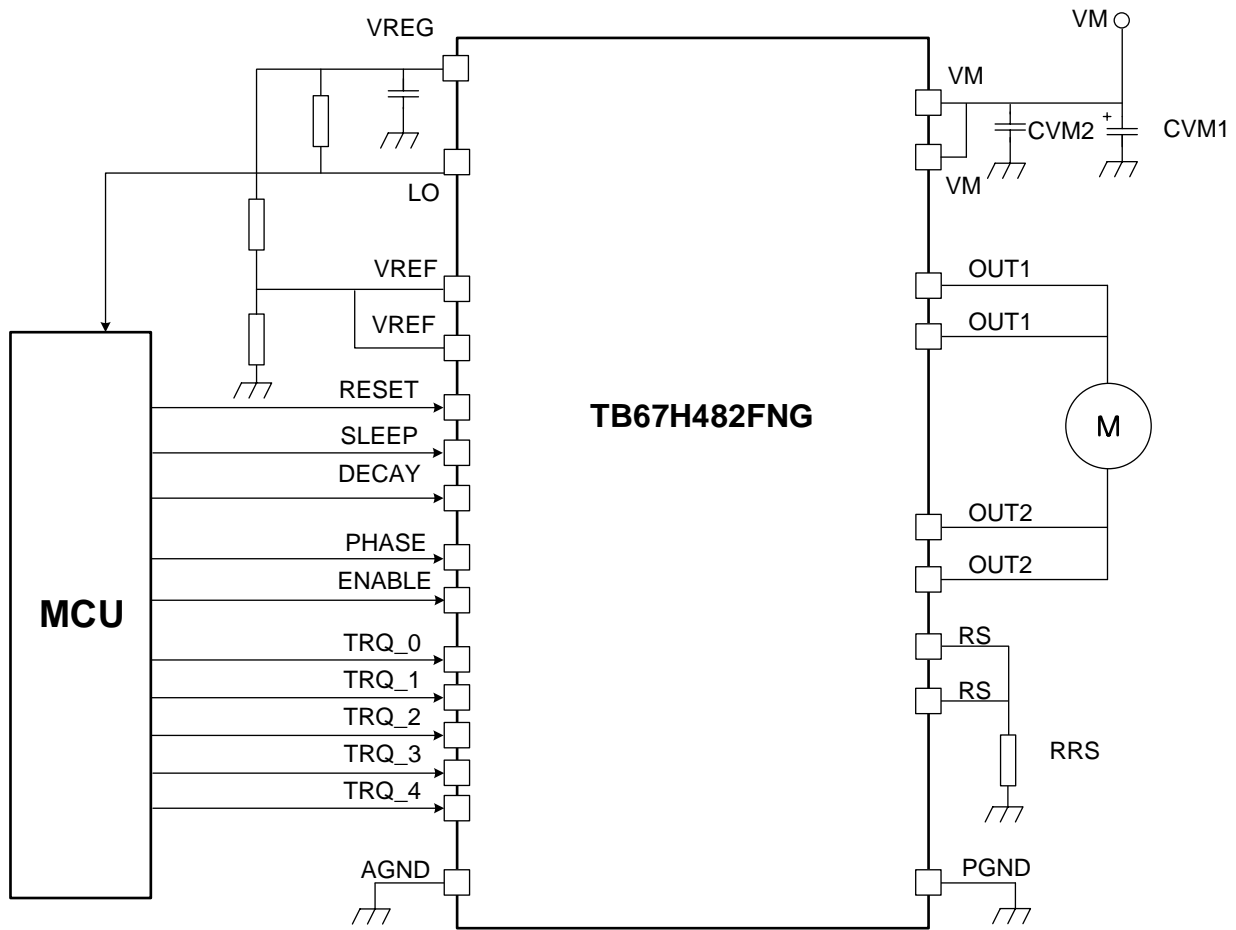

Figure 16.1 AC Electrical Specification Timing Chart

Note: Timing charts may be simplified for explanatory purposes.

**17. Application Circuit Example**

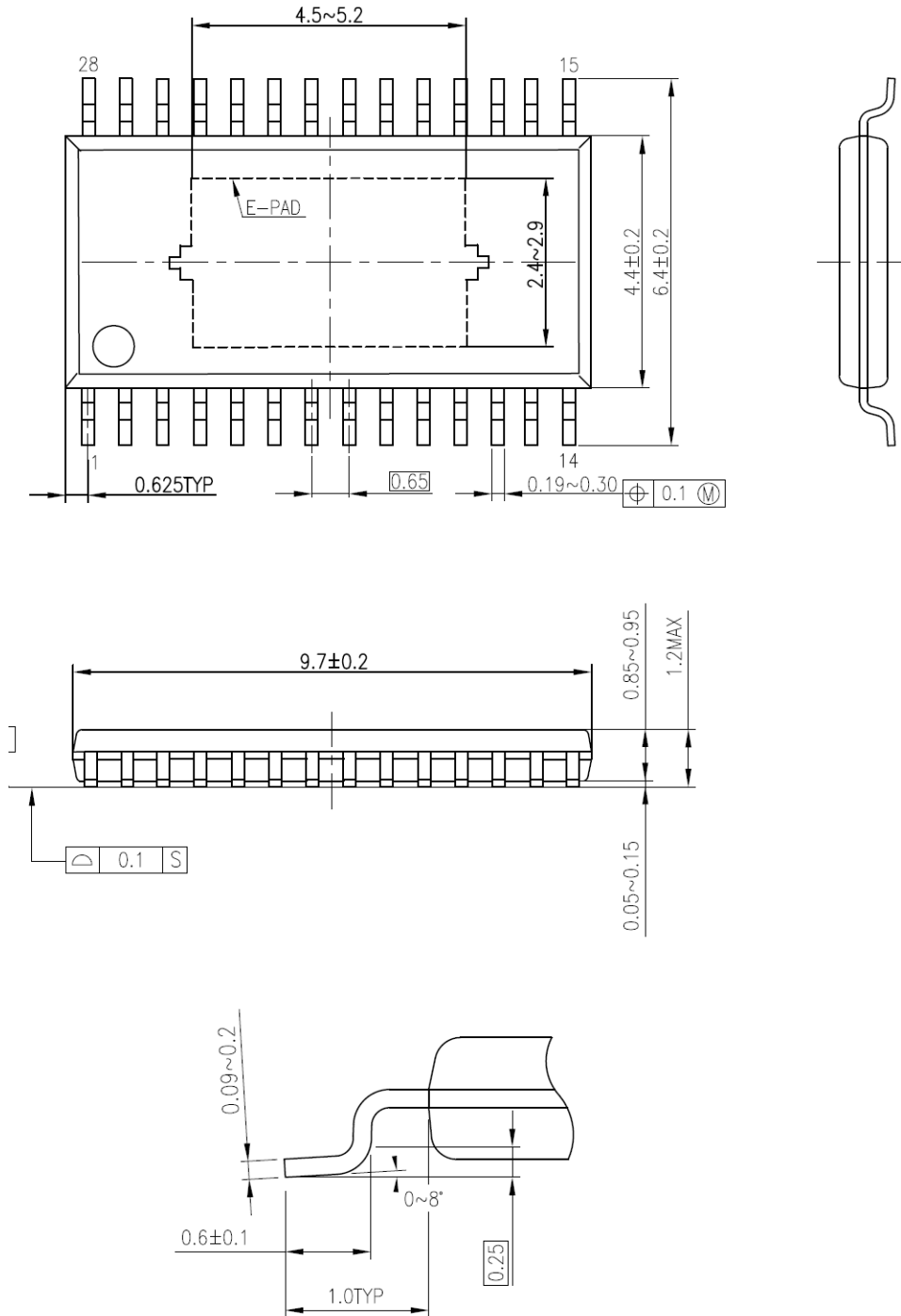

**Figure 17 Application Circuit Example**

**18. Package Dimensions**

P-HTSSOP28-0510-0.65-001

Unit: mm



**Weight: 105 mg (Typ.)**

**Figure 18 Package Dimensions**

## 19. Notes on Contents

### Block Diagrams

Some of the functional blocks, circuits, or constants in the block diagram may be omitted or simplified for explanatory purposes.

### Input / Output Equivalent Circuit

The equivalent circuit diagrams may be simplified for explanatory purposes.

### Timing Charts

Timing charts may be simplified for explanatory purposes.

### Application Circuits

The application circuits shown in this document are provided for reference purposes only. Thorough evaluation is required, especially at the mass production design stage.

Providing these application circuit examples does not grant a license for industrial property rights.

## 20. IC Usage Considerations

### 20.1. Notes on Handling of ICs

- (1) The absolute maximum ratings of a semiconductor device are a set of ratings that must not be exceeded, even for a moment. Do not exceed any of these ratings. Exceeding the rating(s) may cause the device breakdown, damage or deterioration, and may result injury by explosion or combustion.
- (2) Use an appropriate power supply fuse to ensure that a large current does not continuously flow in case of over current and/or IC failure. The IC will fully break down when used under conditions that exceed its absolute maximum ratings, when the wiring is routed improperly or when an abnormal pulse noise occurs from the wiring or load, causing a large current to continuously flow and the breakdown can lead smoke or ignition. To minimize the effects of the flow of a large current in case of breakdown, appropriate settings, such as fuse capacity, fusing time and insertion circuit location, are required.
- (3) If your design includes an inductive load such as a motor coil, incorporate a protection circuit into the design to prevent device malfunction or breakdown caused by the current resulting from the inrush current at power ON or the negative current resulting from the back electromotive force at power OFF. IC breakdown may cause injury, smoke or ignition. Use a stable power supply with ICs with built-in protection functions. If the power supply is unstable, the protection function may not operate, causing IC breakdown. IC breakdown may cause injury, smoke or ignition.
- (4) Do not insert devices in the wrong orientation or incorrectly. Make sure that the positive and negative terminals of power supplies are connected properly. Otherwise, the current or power consumption may exceed the absolute maximum rating, and exceeding the rating(s) may cause the device breakdown, damage or deterioration, and may result injury by explosion or combustion. In addition, do not use any device that is applied the current with inserting in the wrong orientation or incorrectly even just one time.
- (5) Carefully select external components (such as inputs and negative feedback capacitors) and load components (such as speakers), for example, power amp and regulator. If there is a large amount of leakage current such as from input or negative feedback condenser, the IC output DC voltage will increase. If this output voltage is connected to a speaker with low input withstand voltage, overcurrent or IC failure may cause smoke or ignition. (The overcurrent may cause smoke or ignition from the IC itself.) In particular, please pay attention when using a Bridge Tied Load (BTL) connection-type IC that inputs output DC voltage to a speaker directly.



## 20.2. Points to Remember on Handling of ICs

- (1) Over current Protection Circuit  
Over current protection circuits (referred to as current limiter circuits) do not necessarily protect ICs under all circumstances. If the Over current protection circuits operate against the over current, clear the over current status immediately.
- (2) Thermal Shutdown Circuit  
Thermal shutdown circuits do not necessarily protect ICs under all circumstances. If the thermal shutdown circuits operate against the over temperature clears the heat generation status immediately.
- (3) Heat Radiation Design  
In using an IC with large current flow such as power amp, regulator or driver, please design the device so that heat is appropriately radiated, not to exceed the specified junction temperature ( $T_j$ ) at any time and condition. These ICs generate heat even during normal use. An inadequate IC heat radiation design can lead to decrease in IC life, deterioration of IC characteristics or IC breakdown. In addition, please design the device taking into consideration the effect of IC heat radiation with peripheral components.
- (4) Back-EMF  
When a motor reverses the rotation direction, stops or slows down abruptly, a current flow back to the motor's power supply due to the effect of back-EMF. If the current sink capability of the power supply is small, the device's motor power supply and output pins might be exposed to conditions beyond absolute maximum ratings. To avoid this problem, take the effect of back-EMF into consideration in system design.

## RESTRICTIONS ON PRODUCT USE

Toshiba Corporation and its subsidiaries and affiliates are collectively referred to as "TOSHIBA". Hardware, software and systems described in this document are collectively referred to as "Product".

- TOSHIBA reserves the right to make changes to the information in this document and related Product without notice.
- This document and any information herein may not be reproduced without prior written permission from TOSHIBA. Even with TOSHIBA's written permission, reproduction is permissible only if reproduction is without alteration/omission.
- Though TOSHIBA works continually to improve Product's quality and reliability, Product can malfunction or fail. Customers are responsible for complying with safety standards and for providing adequate designs and safeguards for their hardware, software and systems which minimize risk and avoid situations in which a malfunction or failure of Product could cause loss of human life, bodily injury or damage to property, including data loss or corruption. Before customers use the Product, create designs including the Product, or incorporate the Product into their own applications, customers must also refer to and comply with (a) the latest versions of all relevant TOSHIBA information, including without limitation, this document, the specifications, the data sheets and application notes for Product and the precautions and conditions set forth in the "TOSHIBA Semiconductor Reliability Handbook" and (b) the instructions for the application with which the Product will be used with or for. Customers are solely responsible for all aspects of their own product design or applications, including but not limited to (a) determining the appropriateness of the use of this Product in such design or applications; (b) evaluating and determining the applicability of any information contained in this document, or in charts, diagrams, programs, algorithms, sample application circuits, or any other referenced documents; and (c) validating all operating parameters for such designs and applications. **TOSHIBA ASSUMES NO LIABILITY FOR CUSTOMERS' PRODUCT DESIGN OR APPLICATIONS.**
- **PRODUCT IS NEITHER INTENDED NOR WARRANTED FOR USE IN EQUIPMENTS OR SYSTEMS THAT REQUIRE EXTRAORDINARILY HIGH LEVELS OF QUALITY AND/OR RELIABILITY, AND/OR A MALFUNCTION OR FAILURE OF WHICH MAY CAUSE LOSS OF HUMAN LIFE, BODILY INJURY, SERIOUS PROPERTY DAMAGE AND/OR SERIOUS PUBLIC IMPACT ("UNINTENDED USE").** Except for specific applications as expressly stated in this document, Unintended Use includes, without limitation, equipment used in nuclear facilities, equipment used in the aerospace industry, lifesaving and/or life supporting medical equipment, equipment used for automobiles, trains, ships and other transportation, traffic signaling equipment, equipment used to control combustions or explosions, safety devices, elevators and escalators, and devices related to power plant. **IF YOU USE PRODUCT FOR UNINTENDED USE, TOSHIBA ASSUMES NO LIABILITY FOR PRODUCT.** For details, please contact your TOSHIBA sales representative or contact us via our website.
- Do not disassemble, analyze, reverse-engineer, alter, modify, translate or copy Product, whether in whole or in part.
- Product shall not be used for or incorporated into any products or systems whose manufacture, use, or sale is prohibited under any applicable laws or regulations.
- The information contained herein is presented only as guidance for Product use. No responsibility is assumed by TOSHIBA for any infringement of patents or any other intellectual property rights of third parties that may result from the use of Product. No license to any intellectual property right is granted by this document, whether express or implied, by estoppel or otherwise.
- **ABSENT A WRITTEN SIGNED AGREEMENT, EXCEPT AS PROVIDED IN THE RELEVANT TERMS AND CONDITIONS OF SALE FOR PRODUCT, AND TO THE MAXIMUM EXTENT ALLOWABLE BY LAW, TOSHIBA (1) ASSUMES NO LIABILITY WHATSOEVER, INCLUDING WITHOUT LIMITATION, INDIRECT, CONSEQUENTIAL, SPECIAL, OR INCIDENTAL DAMAGES OR LOSS, INCLUDING WITHOUT LIMITATION, LOSS OF PROFITS, LOSS OF OPPORTUNITIES, BUSINESS INTERRUPTION AND LOSS OF DATA, AND (2) DISCLAIMS ANY AND ALL EXPRESS OR IMPLIED WARRANTIES AND CONDITIONS RELATED TO SALE, USE OF PRODUCT, OR INFORMATION, INCLUDING WARRANTIES OR CONDITIONS OF MERCHANTABILITY, FITNESS FOR A PARTICULAR PURPOSE, ACCURACY OF INFORMATION, OR NONINFRINGEMENT.**
- Do not use or otherwise make available Product or related software or technology for any military purposes, including without limitation, for the design, development, use, stockpiling or manufacturing of nuclear, chemical, or biological weapons or missile technology products (mass destruction weapons). Product and related software and technology may be controlled under the applicable export laws and regulations including, without limitation, the Japanese Foreign Exchange and Foreign Trade Law and the U.S. Export Administration Regulations. Export and re-export of Product or related software or technology are strictly prohibited except in compliance with all applicable export laws and regulations.
- Please contact your TOSHIBA sales representative for details as to environmental matters such as the RoHS compatibility of Product. Please use Product in compliance with all applicable laws and regulations that regulate the inclusion or use of controlled substances, including without limitation, the EU RoHS Directive. **TOSHIBA ASSUMES NO LIABILITY FOR DAMAGES OR LOSSES OCCURRING AS A RESULT OF NONCOMPLIANCE WITH APPLICABLE LAWS AND REGULATIONS.**