

# TDS5B212MX, TDS5C212MX

## 1. Functional Description

- 1-64GT/s 1-Lane Two Differential Channel, 2:1 Mux/1:2 De-Mux

## 2. General

TDS5B212MX, TDS5C212MX are high-speed differential channel multiplexer(Mux)/demultiplexer(De-mux) switches. These devices are designed to support up to 64GT/s high-speed differential interface such as PCIe® 6.0, CXL 3.x, USB4®Version 2.0, Thunderbolt™ 5, DisplayPort™ 2.0.

TDS5C212MX and TDS5B212MX have different pin layout. TDS5C212MX has an optimized pin assignment to achieve high frequency performance, while TDS5B212MX uses the same pin layout as conventional products.

The A Port(An+/An-) is connected to either the B Port (Bn+/Bn-) or C Port (Cn+/Cn-), which is determined by the combination of both the select (SEL) and output enable pins ( $\overline{OE}$ ). When the output enable ( $\overline{OE}$ ) is held at a high-level, the switches are open (high-impedance state), regardless of the state of the select, thus these devices have lower consumption current.

For device switch adjustment operations, Port A (An+, An-) has a weak differential resistance of 20 k $\Omega$  between the positive and negative terminals (An+, An-), and a weak pull-down resistance of approximately 1 M $\Omega$  from the An+ and An- terminals to GND.

The devices are designed to operate in temperatures from -40 to 125 °C and can be used for application including industrial use cases.

## 3. Features

- (1) Operating voltage:  $V_{CC} = 1.6$  to  $3.6$  V
- (2) Operating temperature:  $T_{ope} = -40$  to  $125$  °C
- (3) Low current consumption, For active mode(Typ.) :  $I_{ope} = 70\mu A$
- (4) -3-dB Bandwidth (differential)  $BW_{(diff)}$  (Typ.) : TDS5C212MX = 34 GHz  
TDS5B212MX = 29 GHz
- (5) Differential insertion Loss DDIL (Typ.) : TDS5C212MX = -1.2 dB @  $f = 16$  GHz  
TDS5B212MX = -1.2 dB @  $f = 16$  GHz
- (6) Differential return Loss DDRL (Typ.) : TDS5C212MX = -14 dB @  $f = 16$  GHz  
TDS5B212MX = -15 dB @  $f = 16$  GHz
- (7) Differential Off Isolation DDOIRR (Typ.) : TDS5C212MX = -24 dB @  $f = 16$  GHz  
TDS5B212MX = -27 dB @  $f = 16$  GHz
- (8) Differential Crosstalk DDXT (Typ.) : TDS5C212MX = -31 dB @  $f = 16$  GHz  
TDS5B212MX = -31 dB @  $f = 16$  GHz
- (9) Package: XQFN16

## 4. Interfaces

- PCIe 6.0 (PAM4) / 5.0 / 4.0
- Thunderbolt 5 / 4 / 3
- USB 3.2 Gen 2/Gen 1
- CXL 3.x / 2.x / 1.x
- DisplayPort 2.0 / 1.4
- USB4 Version 2.0 , Gen3/Gen2 (PAM3)
- SAS 3.0
- PCIe® is a registered trademark of PCI-SIG.
- USB4® is a registered trademark of USB Implementers Forum.
- Thunderbolt is a trademark of Intel Corporation or its subsidiaries.
- DisplayPort™ is a trademark owned by the Video Electronics Standards Association (VESA®) in the United States and other countries.
- Other company names, products, and service names may be trademarks of their respective companies.

Start of commercial production

2025-11

**5. Packaging**

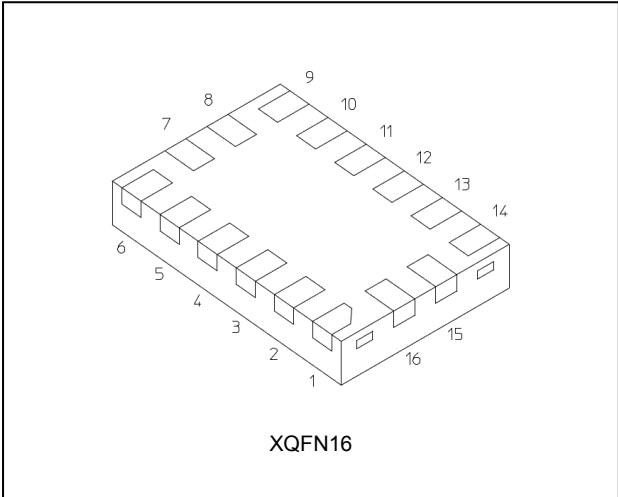

**6. Marking**

TDS5B212MX

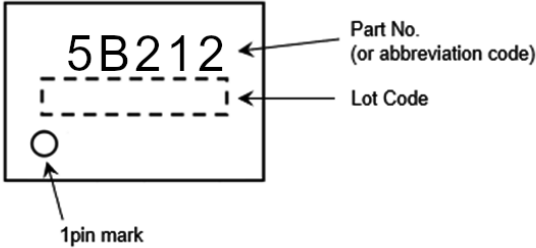

TDS5C212MX

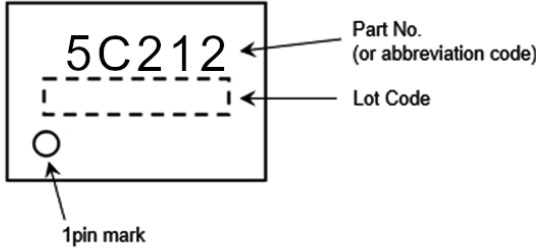

### 7. Pin Assignment

TDS5B212MX

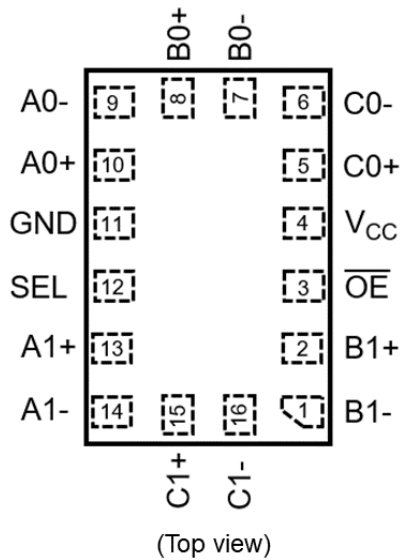

TDS5C212MX

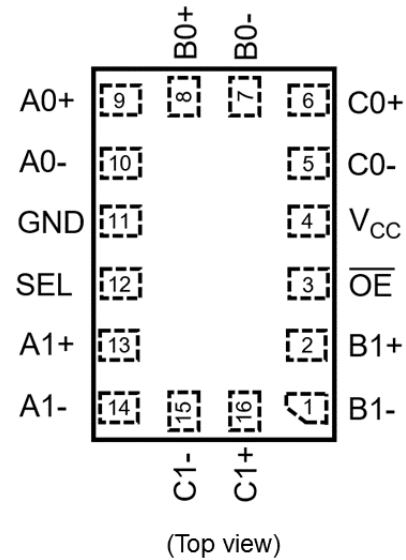

### 8. Block Diagram

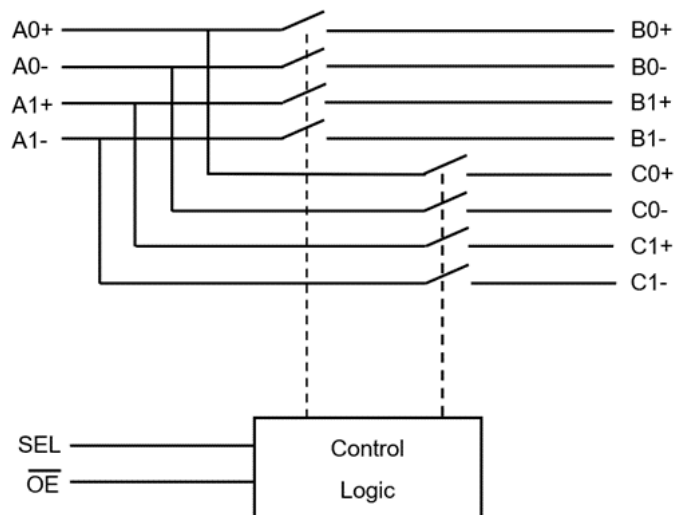

### 9. Truth Table

Inputs $\overline{OE}$	Inputs SEL	Function
L	L	An+ port = Bn+ port, An- port = Bn- port (n=0,1)
L	H	An+ port = Cn+ port, An- port = Cn- port (n=0,1)
H	—	An, Bn, Cn port Disconnect (Standby mode) (n=0,1)

—: Don't care

### 10. Absolute Maximum Ratings (Note)

Characteristics	Symbol	Note	Rating	Unit
Supply voltage	$V_{CC}$		-0.5 to 4.0	V
Input voltage ( $\overline{OE}$ , SEL)	$V_{IN}$		-0.5 to 4.0	V
Switch I/O voltage	$V_S$		-0.5 to 2.5	V
Switch I/O current	$I_S$		32	mA
Power dissipation	$P_D$	(Note 1)	180	mW
$V_{CC}$ /ground current	$I_{CC}/I_{GND}$		$\pm 50$	mA
Storage temperature	$T_{stg}$		-65 to 150	$^{\circ}C$

Note: Exceeding any of the absolute maximum ratings, even briefly, lead to deterioration in IC performance or even destruction.

Using continuously under heavy loads (e.g. the application of high temperature/current/voltage and the significant change in temperature, etc.) may cause this product to decrease in the reliability significantly even if the operating conditions (i.e. operating temperature/current/voltage, etc.) are within the absolute maximum ratings and the operating ranges.

Please design the appropriate reliability upon reviewing the Toshiba Semiconductor Reliability Handbook (“Handling Precautions”/“Derating Concept and Methods”) and individual reliability data (i.e. reliability test report and estimated failure rate, etc).

Note 1: 180 mW in the range of  $T_a = -40$  to  $105^{\circ}C$ . From  $T_a = 105$  to  $125^{\circ}C$  a derating factor of  $-8.5$  mW/ $^{\circ}C$  shall be applied until 10 mW.

### 11. Operating Ranges (Note)

Characteristics	Symbol	Rating	Unit
Supply voltage	$V_{CC}$	1.6 to 3.6	V
Input voltage ( $\overline{OE}$ , SEL)	$V_{IN}$	0 to 3.6	V
Signal pins differential voltage.	$V_{I/O(Diff)}$	0 to 1.8	V
Signal pins common mode voltage.	$V_{I/O(Com)}$	0 to 2.0	V
Operating temperature	$T_{opr}$	-40 to 125	$^{\circ}C$
Input rise and fall times	dt/dv	0 to 10	ns/V

Note: The operating ranges must be maintained to ensure the normal operation of the device.  
Unused control inputs must be tied to either  $V_{CC}$  or GND.

### 12. Electrical Characteristics

#### 12.1. DC Characteristics

##### 12.1.1. DC Characteristics (Note) (Unless otherwise specified, $T_a = -40$ to $85$ °C)

Characteristics	Symbol	Test Condition	$V_{CC}$ (V)	Min	Typ.	Max	Unit
High-level input voltage ( $\overline{OE}$ , SEL)	$V_{IH}$	—	1.65 to 3.6	$0.65 \times V_{CC}$	—	—	V
Low-level input voltage ( $\overline{OE}$ , SEL)	$V_{IL}$	—	1.65 to 3.6	—	—	$0.35 \times V_{CC}$	V
Input leakage current ( $\overline{OE}$ , SEL)	$I_{IN}$	$V_{IN} = 0$ to 3.6 V	1.65 to 3.6	—	—	$\pm 1$	$\mu A$
Switch OFF-state leakage current	$I_{SZ}$	$V_S = 0$ to 2.0V, $\overline{OE} = V_{CC}$	3.6	—	—	$\pm 1$	$\mu A$
ON-resistance	$R_{ON}$	$V_S = 0$ V, $I_S = 8$ mA	3.0	—	—	8.5	$\Omega$
		$V_S = 2$ V, $I_S = 8$ mA	3.0	—	—	10	
Current consumption	$I_{ope}$	$V_S = 0$ V, $\overline{OE} = V_{CC}$ or GND	3.6	—	70	150	$\mu A$
		$V_S = 2$ V, $\overline{OE} = V_{CC}$ or GND	3.6	—	140	300	

Note : All typical values are at  $T_a = 25$  °C.

##### 12.1.2. DC Characteristics (Note) (Unless otherwise specified, $T_a = -40$ to $125$ °C)

Characteristics	Symbol	Test Condition	$V_{CC}$ (V)	Min	Typ.	Max	Unit
High-level input voltage ( $\overline{OE}$ , SEL)	$V_{IH}$	—	1.65 to 3.6	$0.65 \times V_{CC}$	—	—	V
Low-level input voltage ( $\overline{OE}$ , SEL)	$V_{IL}$	—	1.65 to 3.6	—	—	$0.35 \times V_{CC}$	V
Input leakage current ( $\overline{OE}$ , SEL)	$I_{IN}$	$V_{IN} = 0$ to 3.6 V	1.65 to 3.6	—	—	$\pm 1$	$\mu A$
Switch OFF-state leakage current	$I_{SZ}$	$V_S = 0$ to 2.0 V, $\overline{OE} = V_{CC}$	1.65 to 3.6	—	—	$\pm 1$	$\mu A$
ON-resistance	$R_{ON}$	$V_S = 0$ V, $I_S = 8$ mA	3.0	—	—	9.0	$\Omega$
		$V_S = 2$ V, $I_S = 8$ mA	3.0	—	—	12	
Current consumption	$I_{ope}$	$V_S = 0$ V, $\overline{OE} = V_{CC}$ or GND	3.6	—	70	150	$\mu A$
		$V_S = 2$ V, $\overline{OE} = V_{CC}$ or GND	3.6	—	140	300	

Note: All typical values are at  $T_a = 25$  °C.

### 12.2. High frequency characteristics (Note) (Unless otherwise specified, $V_{CC} = 1.6$ to $3.6$ V)

#### 12.2.1. TDS5B212MX

Characteristics	Symbol	Note	Test Condition	Typ.	Unit	
-3-dB Bandwidth (differential)	$BW_{(Diff)}$	(Note 1)	$R_L = 50 \Omega$ , See Fig. 13.1	29	GHz	
Differential insertion loss	DDIL	(Note 1)	$R_L = 50 \Omega$ See Fig. 13.1	f = 2.5 GHz	-0.6	dB
				f = 4.0 GHz	-0.7	
				f = 5.0 GHz	-0.7	
				f = 8.0 GHz	-0.8	
				f = 10.0 GHz	-0.9	
				f = 12.8 GHz	-1.1	
				f = 16.0 GHz	-1.2	
Differential return loss	DDRL	(Note 1)	$R_L = 50 \Omega$ See Fig. 13.1	f = 2.5 GHz	-21	dB
				f = 4.0 GHz	-23	
				f = 5.0 GHz	-20	
				f = 8.0 GHz	-20	
				f = 10.0 GHz	-19	
				f = 12.8 GHz	-20	
				f = 16.0 GHz	-15	
Differential OFF isolation	DDOIRR	(Note 1)	$R_L = 50 \Omega$ See Fig. 13.2	f = 2.5 GHz	-43	dB
				f = 4.0 GHz	-38	
				f = 5.0 GHz	-36	
				f = 8.0 GHz	-29	
				f = 10.0 GHz	-26	
				f = 12.8 GHz	-26	
				f = 16.0 GHz	-27	
Differential Crosstalk	DDXT	(Note 1)	$R_L = 50 \Omega$ See Fig. 13.3, 13.4	f = 2.5 GHz	-47	dB
				f = 4.0 GHz	-43	
				f = 5.0 GHz	-41	
				f = 8.0 GHz	-37	
				f = 10.0 GHz	-35	
				f = 12.8 GHz	-33	
				f = 16.0 GHz	-31	

Note: All typical values are at  $T_a = 25^\circ\text{C}$ .

Note 1: Parameter guaranteed by design.

### 12.2.2. TDS5C212MX

Characteristics	Symbol	Note	Test Condition	Typ.	Unit	
-3-dB Bandwidth (differential)	BW <sub>(Diff)</sub>	(Note 1)	R <sub>L</sub> = 50 Ω, See Fig. 13.1	34	GHz	
Differential insertion loss	DDIL	(Note 1)	R <sub>L</sub> = 50 Ω See Fig. 13.1	f = 2.5 GHz	-0.6	dB
				f = 4.0 GHz	-0.7	
				f = 5.0 GHz	-0.7	
				f = 8.0 GHz	-0.8	
				f = 10.0 GHz	-0.9	
				f = 12.8 GHz	-1.1	
				f = 16.0 GHz	-1.2	
Differential return loss	DDRL	(Note 1)	R <sub>L</sub> = 50 Ω See Fig. 13.1	f = 2.5 GHz	-21	dB
				f = 4.0 GHz	-23	
				f = 5.0 GHz	-21	
				f = 8.0 GHz	-24	
				f = 10.0 GHz	-21	
				f = 12.8 GHz	-20	
				f = 16.0 GHz	-14	
Differential OFF isolation	DDOIRR	(Note 1)	R <sub>L</sub> = 50 Ω See Fig. 13.2	f = 2.5 GHz	-43	dB
				f = 4.0 GHz	-37	
				f = 5.0 GHz	-33	
				f = 8.0 GHz	-27	
				f = 10.0 GHz	-25	
				f = 12.8 GHz	-24	
				f = 16.0 GHz	-24	
Differential Crosstalk	DDXT	(Note 1)	R <sub>L</sub> = 50 Ω See Fig. 13.3, 13.4	f = 2.5 GHz	-47	dB
				f = 4.0 GHz	-43	
				f = 5.0 GHz	-41	
				f = 8.0 GHz	-37	
				f = 10.0 GHz	-35	
				f = 12.8 GHz	-33	
				f = 16.0 GHz	-31	

Note: All typical values are at T<sub>a</sub> = 25 °C.

Note 1: Parameter guaranteed by design.

### 12.3. Switching Characteristics (Unless otherwise specified, $T_a = 25\text{ °C}$ )

#### 12.3.1. TDS5B212MX

Characteristics	Symbol	Note	Test Condition	$V_{CC}$ (V)	Typ.	Unit
Propagation delay time	$t_{PLH}/t_{PHL}$	(Note 1)	$R_L = 50\ \Omega$ , $f = 16\text{ GHz}$ See Fig. 13.1, 13.7	3.3	26	ps
Output skew (bit to bit)	$t_{SK(b)}$	(Note 1)	$R_L = 50\ \Omega$ , $f = 1\text{ GHz}$ See Fig. 13.1, 13.8	3.3	2	ps
Output skew (channel to channel)	$t_{SK(CH)}$	(Note 1)	$R_L = 50\ \Omega$ , $f = 16\text{ GHz}$ See Fig. 13.1, 13.7	3.3	2	ps

Note 1: Parameter guaranteed by design.

#### 12.3.2. TDS5C212MX

Characteristics	Symbol	Note	Test Condition	$V_{CC}$ (V)	Typ.	Unit
Propagation delay time	$t_{PLH}/t_{PHL}$	(Note 1)	$R_L = 50\ \Omega$ , $f = 16\text{ GHz}$ See Fig. 13.1, 13.7	3.3	26	ps
Output skew (bit to bit)	$t_{SK(b)}$	(Note 1)	$R_L = 50\ \Omega$ , $f = 1\text{ GHz}$ See Fig. 13.1, 13.8	3.3	3	ps
Output skew (channel to channel)	$t_{SK(CH)}$	(Note 1)	$R_L = 50\ \Omega$ , $f = 16\text{ GHz}$ See Fig. 13.1, 13.7	3.3	2	ps

Note 1: Parameter guaranteed by design.

### 12.4. Timing characteristics

#### 12.4.1. Timing characteristics (Unless otherwise specified, $T_a = -40\text{ to }85\text{ °C}$ )

Characteristics	Symbol	Test Condition	$V_{CC}$ (V)	Min	Typ.	Max	Unit
Start-up time.	$t_{sup}$	$R_L = 50\ \Omega$ , $C_L = 5\text{ pF}$ See Fig. 13.5	1.65 to 3.6	—	—	100	$\mu\text{s}$
Turn-ON time (SEL to Output)	$t_{on}$	$R_L = 50\ \Omega$ , $C_L = 5\text{ pF}$ See Fig. 13.5	1.65 to 3.6	—	—	400	ns
Turn-ON time ( $\overline{OE}$ to Output)			1.65 to 3.6	—	—	400	
Turn-OFF time (SEL to Output)	$t_{off}$	$R_L = 50\ \Omega$ , $C_L = 5\text{ pF}$ See Fig. 13.5	1.65 to 3.6	—	—	100	ns
Turn-OFF time ( $\overline{OE}$ to Output)			1.65 to 3.6	—	—	100	
Break before make	TBBM	$R_L = 50\ \Omega$ , $C_L = 5\text{ pF}$ See Fig. 13.6	1.65 to 3.6	55	—	400	ns

#### 12.4.2. Timing characteristics (Unless otherwise specified, $T_a = -40\text{ to }125\text{ °C}$ )

Characteristics	Symbol	Test Condition	$V_{CC}$ (V)	Min	Typ.	Max	Unit
Start-up time.	$t_{sup}$	$R_L = 50\ \Omega$ , $C_L = 5\text{ pF}$ See Fig. 13.5	1.65 to 3.6	—	—	110	$\mu\text{s}$
Turn-ON time (SEL to Output)	$t_{on}$	$R_L = 50\ \Omega$ , $C_L = 5\text{ pF}$ See Fig. 13.5	1.65 to 3.6	—	—	450	ns
Turn-ON time ( $\overline{OE}$ to Output)			1.65 to 3.6	—	—	450	
Turn-OFF time (SEL to Output)	$t_{off}$	$R_L = 50\ \Omega$ , $C_L = 5\text{ pF}$ See Fig. 13.5	1.65 to 3.6	—	—	110	ns
Turn-OFF time ( $\overline{OE}$ to Output)			1.65 to 3.6	—	—	110	
Break before make	TBBM	$R_L = 50\ \Omega$ , $C_L = 5\text{ pF}$ See Fig. 13.6	1.65 to 3.6	55	—	450	ns

**13. Electrical Test Circuit (Fig)**

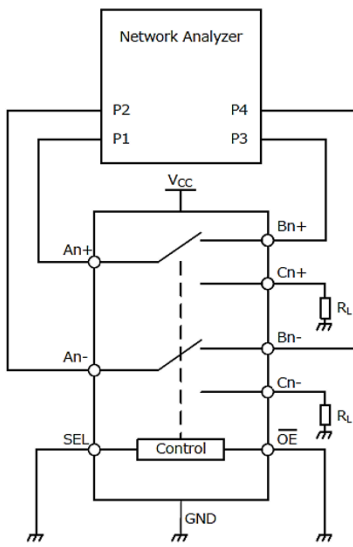

$R_L = 50 \Omega$   
 All unused ports are connected to GND through  $50 \Omega$  pull-down resistors.  
 This figure is an example showing how to measure An and Bn.

**Fig. 13.1 -3-dB Bandwidth(differential), Differential insertion loss, Differential return loss, Propagation delay time, Output skew (channel to channel, bit to bit)**

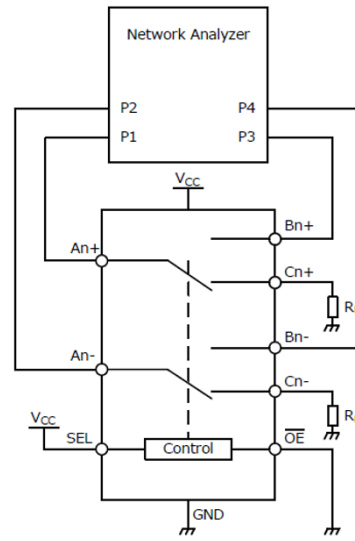

$R_L = 50 \Omega$   
 All unused ports are connected to GND through  $50 \Omega$  pull-down resistors.  
 This figure is an example showing how to measure An and Bn.

**Fig. 13.2 Differential OFF isolation**

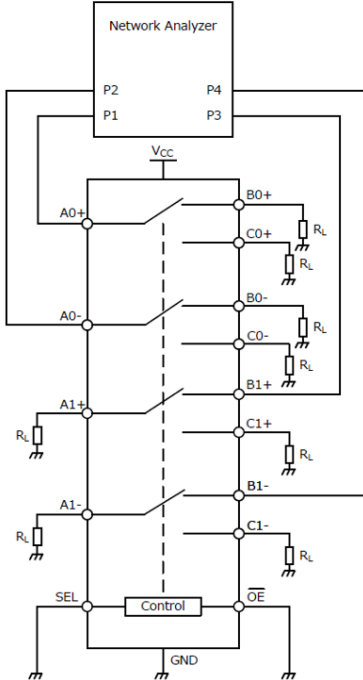

$R_L = 50 \Omega$   
 All unused ports are connected to GND through  $50 \Omega$  pull-down resistors.  
 This figure is an example showing how to measure A0 and B1.

**Fig. 13.3 Differential Far-end crosstalk**

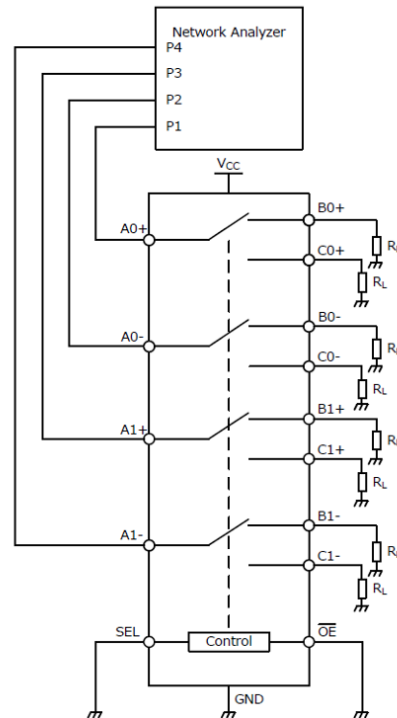

$R_L = 50 \Omega$   
 All unused ports are connected to GND through  $50 \Omega$  pull-down resistors.  
 This figure is an example showing how to measure A0 and A1.

**Fig. 13.4 Differential Near-end crosstalk**

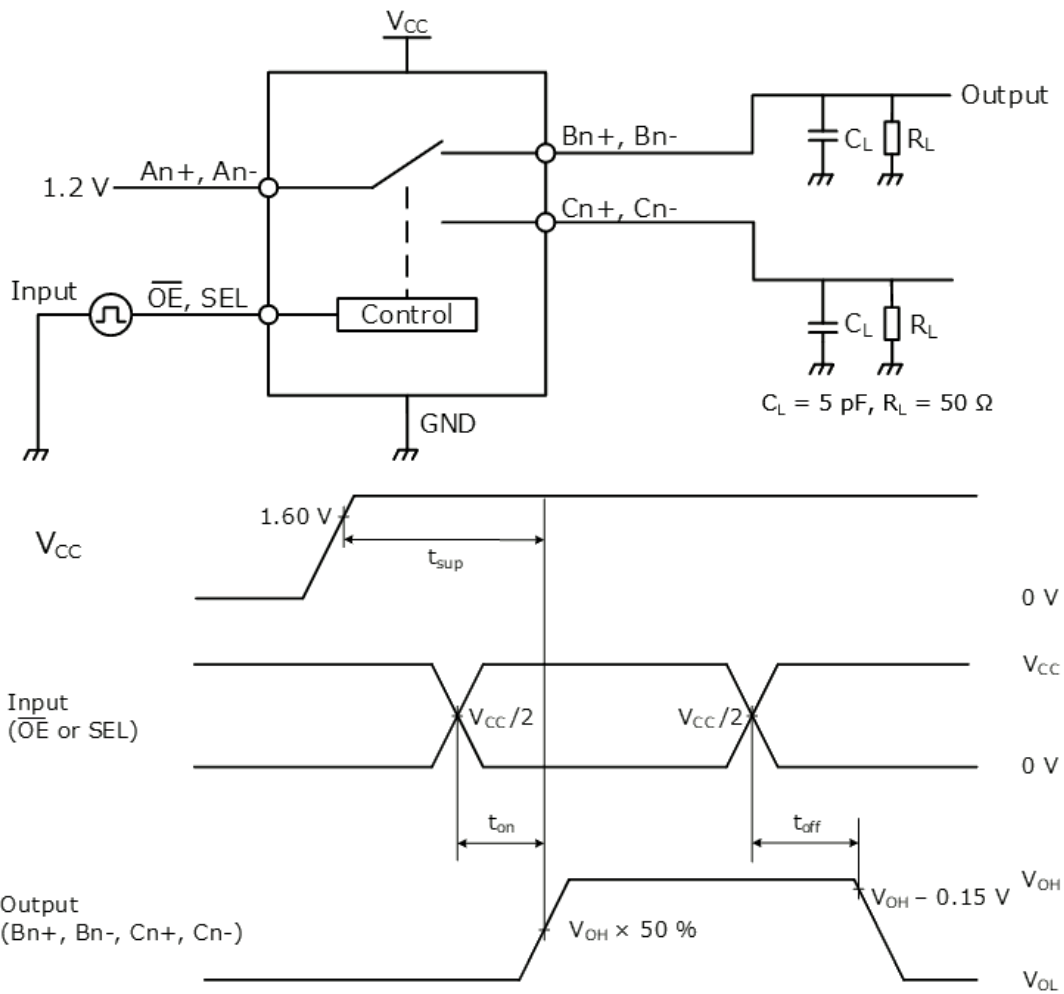
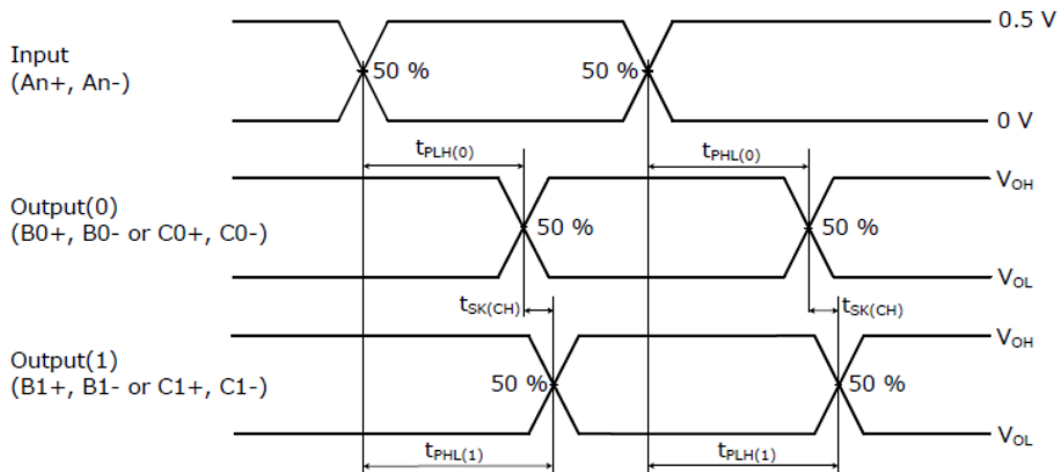
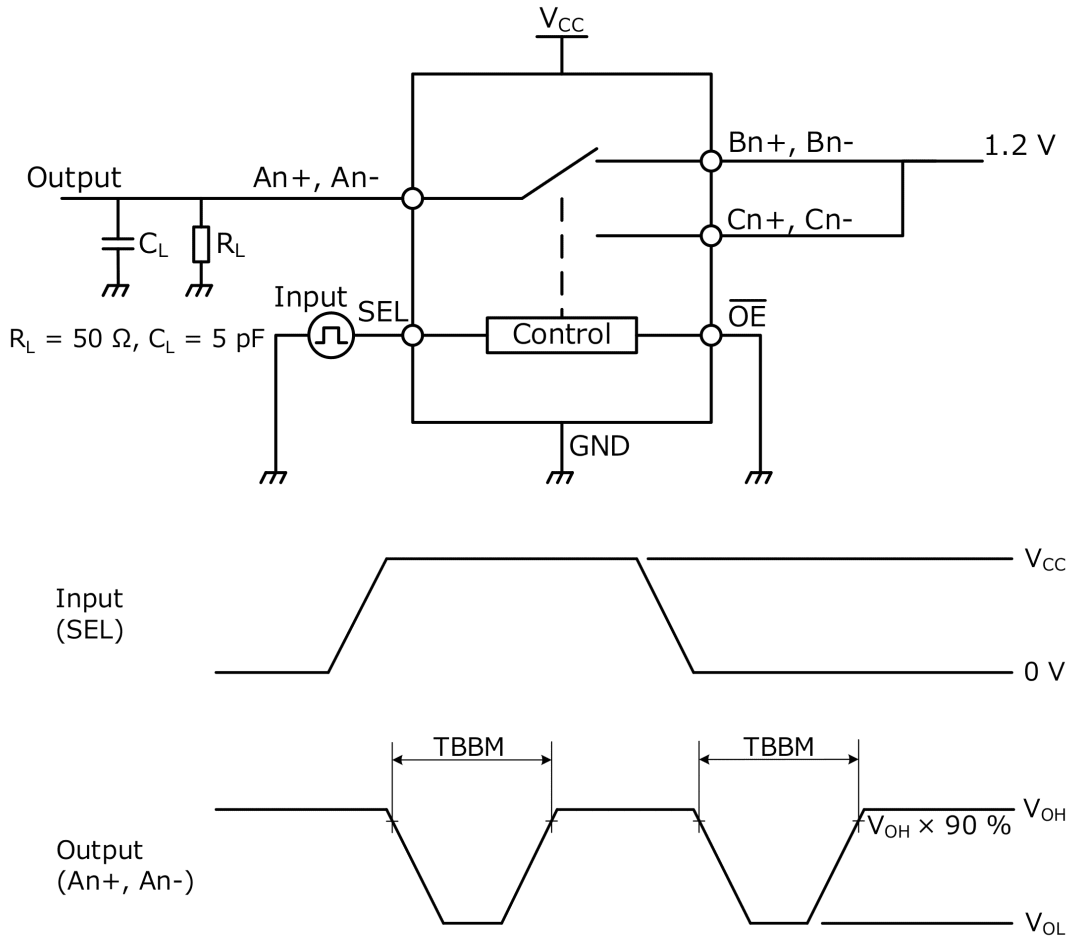

Fig. 13.5 Start-up time, Turn-ON time and Turn-OFF time



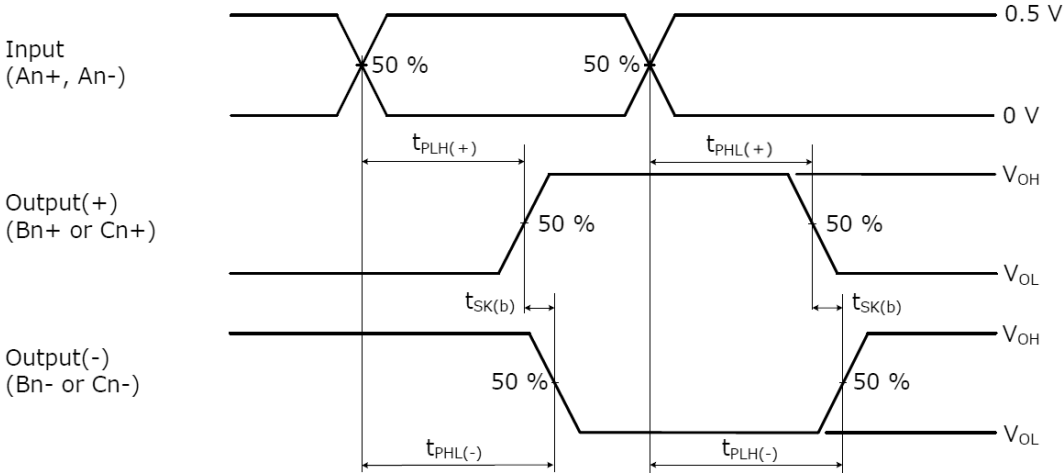
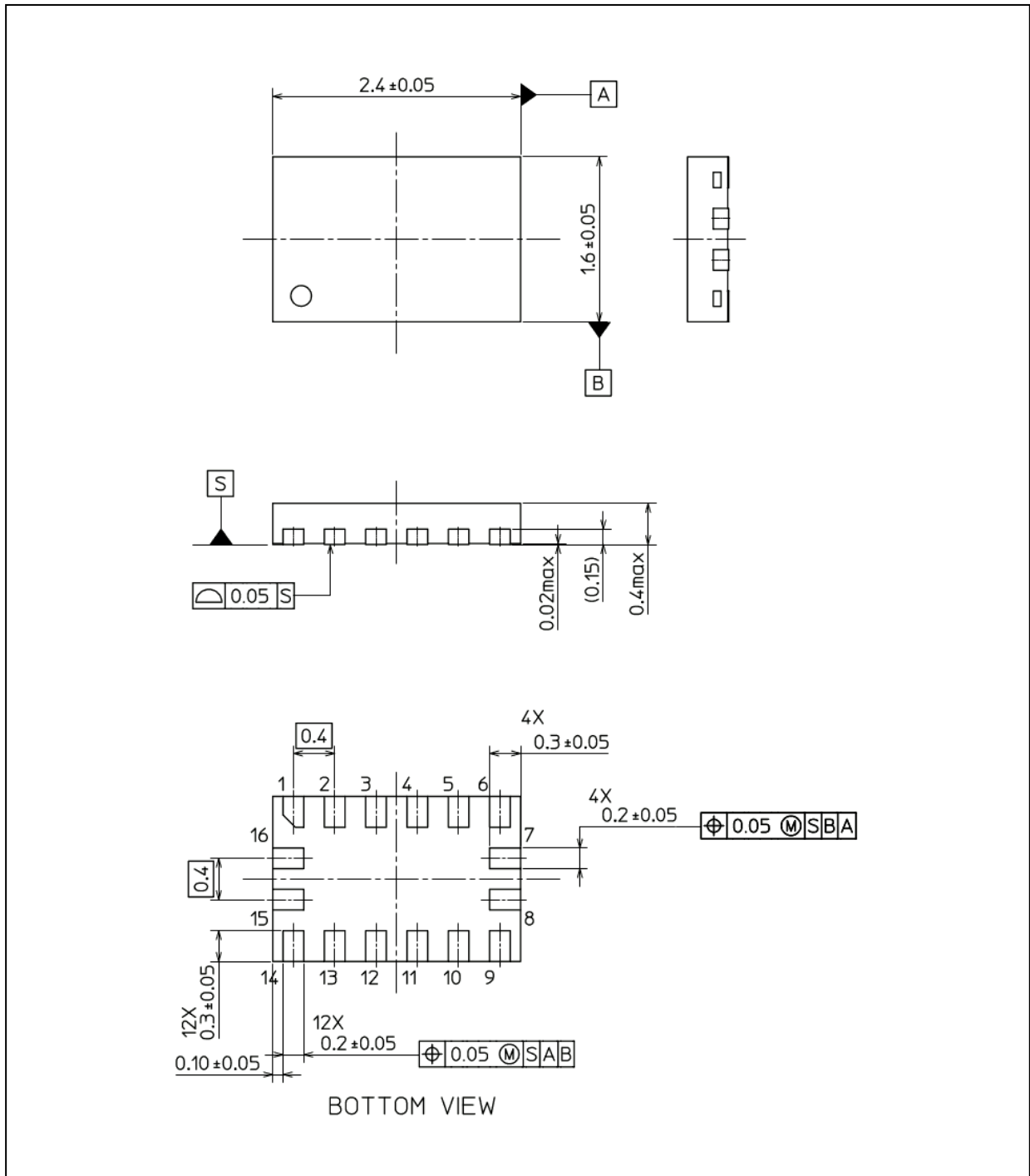

Fig. 13.8 Output skew (bit to bit)

## Package Dimensions

Unit: mm



Weight: 3.9 mg (typ.)

Package Name(s)
Nickname: XQFN16

## RESTRICTIONS ON PRODUCT USE

Toshiba Corporation and its subsidiaries and affiliates are collectively referred to as "TOSHIBA".

Hardware, software and systems described in this document are collectively referred to as "Product".

- TOSHIBA reserves the right to make changes to the information in this document and related Product without notice.
- This document and any information herein may not be reproduced without prior written permission from TOSHIBA. Even with TOSHIBA's written permission, reproduction is permissible only if reproduction is without alteration/omission.
- Though TOSHIBA works continually to improve Product's quality and reliability, Product can malfunction or fail. Customers are responsible for complying with safety standards and for providing adequate designs and safeguards for their hardware, software and systems which minimize risk and avoid situations in which a malfunction or failure of Product could cause loss of human life, bodily injury or damage to property, including data loss or corruption. Before customers use the Product, create designs including the Product, or incorporate the Product into their own applications, customers must also refer to and comply with (a) the latest versions of all relevant TOSHIBA information, including without limitation, this document, the specifications, the data sheets and application notes for Product and the precautions and conditions set forth in the "TOSHIBA Semiconductor Reliability Handbook" and (b) the instructions for the application with which the Product will be used with or for. Customers are solely responsible for all aspects of their own product design or applications, including but not limited to (a) determining the appropriateness of the use of this Product in such design or applications; (b) evaluating and determining the applicability of any information contained in this document, or in charts, diagrams, programs, algorithms, sample application circuits, or any other referenced documents; and (c) validating all operating parameters for such designs and applications.  
**TOSHIBA ASSUMES NO LIABILITY FOR CUSTOMERS' PRODUCT DESIGN OR APPLICATIONS.**

- **PRODUCT IS NEITHER INTENDED NOR WARRANTED FOR USE IN EQUIPMENTS OR SYSTEMS THAT REQUIRE EXTRAORDINARILY HIGH LEVELS OF QUALITY AND/OR RELIABILITY, AND/OR A MALFUNCTION OR FAILURE OF WHICH MAY CAUSE LOSS OF HUMAN LIFE, BODILY INJURY, SERIOUS PROPERTY DAMAGE AND/OR SERIOUS PUBLIC IMPACT ("UNINTENDED USE").**

Except for specific applications as expressly stated in this document, Unintended Use includes, without limitation, equipment used in nuclear facilities, equipment used in the aerospace industry, lifesaving and/or life supporting medical equipment, equipment used for automobiles, trains, ships and other transportation, traffic signaling equipment, equipment used to control combustions or explosions, safety devices, elevators and escalators, and devices related to power plant.

**IF YOU USE PRODUCT FOR UNINTENDED USE, TOSHIBA ASSUMES NO LIABILITY FOR PRODUCT.**

For details, please contact your TOSHIBA sales representative or contact us via our website.

- Do not disassemble, analyze, reverse-engineer, alter, modify, translate or copy Product, whether in whole or in part.
- Product shall not be used for or incorporated into any products or systems whose manufacture, use, or sale is prohibited under any applicable laws or regulations.
- The information contained herein is presented only as guidance for Product use. No responsibility is assumed by TOSHIBA for any infringement of patents or any other intellectual property rights of third parties that may result from the use of Product. No license to any intellectual property right is granted by this document, whether express or implied, by estoppel or otherwise.
- **ABSENT A WRITTEN SIGNED AGREEMENT, EXCEPT AS PROVIDED IN THE RELEVANT TERMS AND CONDITIONS OF SALE FOR PRODUCT, AND TO THE MAXIMUM EXTENT ALLOWABLE BY LAW, TOSHIBA (1) ASSUMES NO LIABILITY WHATSOEVER, INCLUDING WITHOUT LIMITATION, INDIRECT, CONSEQUENTIAL, SPECIAL, OR INCIDENTAL DAMAGES OR LOSS, INCLUDING WITHOUT LIMITATION, LOSS OF PROFITS, LOSS OF OPPORTUNITIES, BUSINESS INTERRUPTION AND LOSS OF DATA, AND (2) DISCLAIMS ANY AND ALL EXPRESS OR IMPLIED WARRANTIES AND CONDITIONS RELATED TO SALE, USE OF PRODUCT, OR INFORMATION, INCLUDING WARRANTIES OR CONDITIONS OF MERCHANTABILITY, FITNESS FOR A PARTICULAR PURPOSE, ACCURACY OF INFORMATION, OR NONINFRINGEMENT.**
- Do not use or otherwise make available Product or related software or technology for any military purposes, including without limitation, for the design, development, use, stockpiling or manufacturing of nuclear, chemical, or biological weapons or missile technology products (mass destruction weapons). Product and related software and technology may be controlled under the applicable export laws and regulations including, without limitation, the Japanese Foreign Exchange and Foreign Trade Law and the U.S. Export Administration Regulations. Export and re-export of Product or related software or technology are strictly prohibited except in compliance with all applicable export laws and regulations.
- Please contact your TOSHIBA sales representative for details as to environmental matters such as the RoHS compatibility of Product. Please use Product in compliance with all applicable laws and regulations that regulate the inclusion or use of controlled substances, including without limitation, the EU RoHS Directive. **TOSHIBA ASSUMES NO LIABILITY FOR DAMAGES OR LOSSES OCCURRING AS A RESULT OF NONCOMPLIANCE WITH APPLICABLE LAWS AND REGULATIONS.**