

CMOS Digital Integrated Circuit Silicon Monolithic

TC358841XBG

Mobile Peripheral Devices

Overview

TC358841XBG, Ultra HD to CSI-2, bridge converts high resolution HDMI® stream to MIPI® CSI-2® Tx video. It is a follow up device of TC358743XBG. The HDMI-RX runs at 297 MHz to carry up to 7.2 Gbps video stream. It requires dual link MIPI CSI-2 Tx, 1 Gbps/data lane, to transmit out a maximum 7.2 Gbps video data.

The bridge chip is necessary for current and next generation Application Processors which have been designed without video stream input port except CSI-2 Rx.

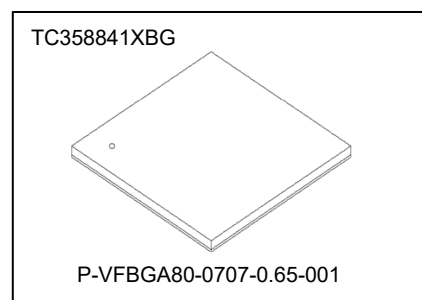

Weight: 67 mg (typ.)

Features

● HDMI-RX Interface

- HDMI-RX
 - Video Formats Support (Up to 4K×2K / 30fps), maximum 24 bps (bit-per-pixel) no deep color support
 - RGB, YCbCr444: 24-bpp
 - YCbCr422: 24-bpp
 - Color Conversion
 - 4:2:2 to 4:4:4 is supported
 - 4:4:4 to 4:2:2 is supported
 - RGB888 to YCbCr (4:4:4 / 4:2:2) is supported
 - YCbCr (4:4:4 / 4:2:2) to RGB888/666 is supported
 - Note: for RGB666 (R=R[5:0],2'b00, G=G[5:0],2'b00, B=B[5:0],2'b00)
 - Maximum HDMI clock speed: 297 MHz
 - Audio Supports
 - Internal Audio PLL to track N/CTS value transmitted by the ACR packet.
 - 3D Support
 - Support HDCP®1.4 decryptions (optional)
 - EDID Support, Release A, Revision 1 (Feb 9, 2000)
 - First 128 byte (EDID 1.3 structure)
 - First E-EDID Extension: 128 bytes of CEA Extension version 3 (specified in CEA-861-D)
 - Embedded 1K-byte SRAM (EDID_SRAM)
 - Does not support Audio Return Path and HDMI Ethernet Channels

● CSI-2 TX Interface

- MIPI CSI-2 compliant
- Dual links CSI-2 (CSI0 and CSI1), each link supports 4 data lanes @ 1 Gbps/data lane
 - CSI0 carries the left half data of HDMI Rx video stream and CSI1 carries the right one at the default configuration.
 - Left or right data can be assigned/programmed to either CSI-2 Tx link
 - The maximum length of each half is limited to

2048-pixel, CSI0 data length could be different from that of CSI1's

- The maximum Hsync skew between CSI0 and CSI1 can be less than 10 ByteClk
- Single link CSI-2, maximum horizontal pixel width
 - 2558 pixels (24-bit per pixel)
 - 3411 pixels (16-bit per pixel)
- HDMI InfoFrame data can be transmit over MIPI CSI-2 at the beginning of each frame (after FS short packet)
- Supports video data formats
 - RGB666, RGB888, YCbCr444, YCbCr 422 24-bit and YCbCr 422 16-bit
 - YCbCr inputs can be converted into RGB before outputting and vice versa.

● I²C Interface

- Support for normal (100 kHz), fast mode (400 kHz) and ultrafast mode (2 MHz)
- Target Mode
 - To be used by an external Controller to configure all TC358841XBG internal registers, including EDID_SRAM
- Support 2 I²C Target Addresses (0x0F & 0x1F) selected through boot-strap pin (INT)

● Audio Output Interface

- Up to four I²S data lines for supporting multi-Channel audio data (5.1 and 7.1)
- Maximum audio sample frequency supported is 192 kHz @8 CH
- Support 16, 18, 20 or 24-bit data (depend on HDMI input stream)
- Support Controller Clock output only
- Support 32 bit-wide time-slot only
- Output Audio Over Sampling clock (256fs)
- Either I²S or TDM Audio interface available (pins are multiplexed)
- I²S Audio Interface

-
- Support Left or Right-justify with MSB first
 - TDM (Time Division Multiplexed) Audio Interface
 - Fixed to 8 channels (depend on HDMI input stream)
 - Digital Audio Interface
 - Supports HBR audio stream split across 4 I²S lines if bandwidth higher than 12 MHz
- **Power Consumption during typical operations**
 - 1920×1080 @60 fps: 420 mW (Dual D-PHY link)
 - 2560×1600 @60 fps: 504 mW (Dual D-PHY link)
 - 3840×2160 @30 fps: 520 mW (Dual D-PHY link)
- **InfraRed (IR)**
 - Support NEC InfraRed protocol.
- **Power supply inputs**
 - Core: 1.15 V
 - MIPI D-PHYSM: 1.2 V
 - I/O: 1.8 V, 3.3 V
 - HDMI-RX: 3.3 V
 - APLL: 3.3 V

Table of contents

| | |
|--|----|
| REFERENCES | 6 |
| 1. Overview | 7 |
| 2. External Pins | 8 |
| 2.1. TC358841XBG 80-Pin Count Summary | 10 |
| 2.2. Pin Layout..... | 10 |
| 3. Package | 11 |
| 4. Electrical Characteristics..... | 12 |
| 4.1. Absolute Maximum Ratings..... | 12 |
| 4.2. Operating Condition..... | 12 |
| 4.3. DC Electrical Specification | 13 |
| 5. External Circuit Recommendation | 15 |
| 5.1. I ² C Target address definition..... | 15 |
| 5.2. DDC_SDA/DDC_SCL..... | 15 |
| 5.3. Audio PLL | 16 |
| 5.4. Recommended power supply circuit | 17 |
| 6. Revision History | 20 |
| RESTRICTIONS ON PRODUCT USE..... | 21 |

List of Figures

| | |
|---|----|
| Figure 1.1 TC358841XBG System Overview | 7 |
| Figure 2.1 TC358841XBG 80-Pin Layout (Top View)..... | 10 |
| Figure 3.1 TC358841XBG package (P-VFBGA80-0707-0.65-001) | 11 |
| Figure 5.1 Example of DDC I/F Connection | 15 |
| Figure 5.2 Connection of REXT resistance..... | 16 |
| Figure 5.3 Audio Clock External LPF circuit block diagram..... | 16 |
| Figure 5.4 Recommended power supply circuit with external switch | 17 |
| Figure 5.5 Recommended power supply circuit with current protection regulator | 18 |
| Figure 5.6 Recommended power supply circuit at VDDIO18 = 3.3 V | 19 |

List of Tables

| | |
|--|----|
| Table 2.1 TC358841XBG Functional Signal List | 8 |
| Table 2.2 BGA80 Pin Count Summary | 10 |
| Table 3.1 Mechanical Dimension | 11 |
| Table 6.1 Revision History | 20 |

- The terms HDMI, HDMI High-Definition Multimedia Interface, HDMI Trade dress and the HDMI Logos are trademarks or registered trademarks of HDMI Licensing Administrator, Inc.
- HDCP is a registered trademark of Digital Content Protection, LLC.
- MIPI, CSI-2, D-PHY are trademarks, service marks, registered service marks of MIPI Alliance, Inc.

1 NOTICE OF DISCLAIMER

2 The material contained herein is not a license, either expressly or impliedly, to any IPR owned or controlled
3 by any of the authors or developers of this material or MIPI. The material contained herein is provided on
4 an "AS IS" basis and to the maximum extent permitted by applicable law, this material is provided AS IS
5 AND WITH ALL FAULTS, and the authors and developers of this material and MIPI hereby disclaim all
6 other warranties and conditions, either express, implied or statutory, including, but not limited to, any (if
7 any) implied warranties, duties or conditions of merchantability, of fitness for a particular purpose, of
8 accuracy or completeness of responses, of results, of workmanlike effort, of lack of viruses, and of lack of
9 negligence.

10 All materials contained herein are protected by copyright laws, and may not be reproduced, republished,
11 distributed, transmitted, displayed, broadcast or otherwise exploited in any manner without the express
12 prior written permission of MIPI Alliance. MIPI, MIPI Alliance and the dotted rainbow arch and all related
13 trademarks, trade names, and other intellectual property are the exclusive property of MIPI Alliance and
14 cannot be used without its express prior written permission.

15 ALSO, THERE IS NO WARRANTY OF CONDITION OF TITLE, QUIET ENJOYMENT, QUIET
16 POSSESSION, CORRESPONDENCE TO DESCRIPTION OR NON-INFRINGEMENT WITH REGARD
17 TO THIS MATERIAL OR THE CONTENTS OF THIS DOCUMENT. IN NO EVENT WILL ANY
18 AUTHOR OR DEVELOPER OF THIS MATERIAL OR THE CONTENTS OF THIS DOCUMENT OR
19 MIPI BE LIABLE TO ANY OTHER PARTY FOR THE COST OF PROCURING SUBSTITUTE
20 GOODS OR SERVICES, LOST PROFITS, LOSS OF USE, LOSS OF DATA, OR ANY INCIDENTAL,
21 CONSEQUENTIAL, DIRECT, INDIRECT, OR SPECIAL DAMAGES WHETHER UNDER
22 CONTRACT, TORT, WARRANTY, OR OTHERWISE, ARISING IN ANY WAY OUT OF THIS OR
23 ANY OTHER AGREEMENT, SPECIFICATION OR DOCUMENT RELATING TO THIS MATERIAL,
24 WHETHER OR NOT SUCH PARTY HAD ADVANCE NOTICE OF THE POSSIBILITY OF SUCH
25 DAMAGES.

26 Without limiting the generality of this Disclaimer stated above, the user of the contents of this Document is
27 further notified that MIPI: (a) does not evaluate, test or verify the accuracy, soundness or credibility of the
28 contents of this Document; (b) does not monitor or enforce compliance with the contents of this Document;
29 and (c) does not certify, test, or in any manner investigate products or services or any claims of compliance
30 with the contents of this Document. The use or implementation of the contents of this Document may
31 involve or require the use of intellectual property rights ("IPR") including (but not limited to) patents,
32 patent applications, or copyrights owned by one or more parties, whether or not Members of MIPI. MIPI
33 does not make any search or investigation for IPR, nor does MIPI require or request the disclosure of any
34 IPR or claims of IPR as respects the contents of this Document or otherwise.

35 Questions pertaining to this document, or the terms or conditions of its provision, should be addressed to:

36 MIPI Alliance, Inc.
37 c/o IEEE-ISTO
38 445 Hoes Lane
39 Piscataway, NJ 08854
40 Attn: Board Secretary

REFERENCES

1. MIPI D-PHY, “MIPI_D-PHY_specification_v01-00-00, May 14, 2009”
2. MIPI CSI-2, “MIPI Alliance Standard for Camera Serial Interface 2 (CSI-2) Version 1.01 Revision Nov 2010”
3. HDMI, “High-Definition Multimedia Interface Specification Version 1.4b October 11, 2011”
4. I²C bus specification, version 2.1, January 2000, Philips Semiconductor

1. Overview

TC358841XBG, Ultra HD to CSI-2, bridge converts high resolution HDMI stream to MIPI CSI-2 Tx video. It is a follow up device of TC358743XBG. The HDMI-RX runs at 297 MHz to carry up to 7.2 Gbps video stream. It requires dual link MIPI CSI-2 Tx, 1 Gbps/data lane, to transmit out a maximum 7.2 Gbps video data.

The bridge chip is necessary for current and next generation Application Processors which have been designed without video stream input port except CSI-2 Rx.

TC358841XBG system view block diagrams is shown in Figure 1.1.

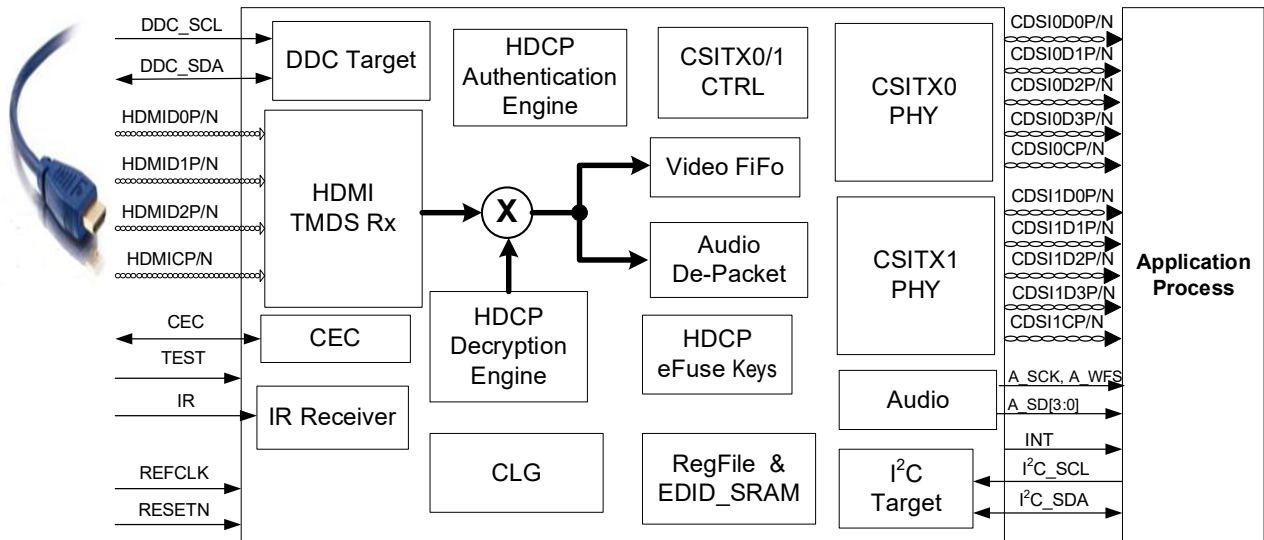

Figure 1.1 TC358841XBG System Overview

2. External Pins

TC358841XBG resides in BGA80 pin packages. The following table gives the signals of TC358841XBG and their function.

Table 2.1 TC358841XBG Functional Signal List

| Group | Pin Name | Ball | I/O | Init (O) | Type (Note 1) | Function | Voltage Supply |
|---------------------------|----------------------|------|-----|----------|---------------|---|----------------|
| System: Reset & Clock (4) | RESETN | K8 | I | - | Sch | System reset input (active low) | VDDIO18 |
| | REFCLK | K9 | I | - | Sch | Reference clock input (40 to 50 MHz) | VDDIO18 |
| | TEST | G5 | I | - | N | Internal test terminal (Always must be fixed low externally) | VDDIO18 |
| | INT | J3 | O | L | N | Interrupt Output signal (active high) (Note 2) | VDDIO18 |
| CDSI TX0 (10) | CDSI0CP | F10 | O | H | MIPI-PHY | MIPI-CSIO clock positive | VDD12_MIPI0 |
| | CDSI0CN | F9 | O | H | MIPI-PHY | MIPI-CSIO clock negative | VDD12_MIPI0 |
| | CDSI0D0P | H10 | O | H | MIPI-PHY | MIPI-CSIO data 0 positive | VDD12_MIPI0 |
| | CDSI0D0N | H9 | O | H | MIPI-PHY | MIPI-CSIO data 0 negative | VDD12_MIPI0 |
| | CDSI0D1P | G10 | O | H | MIPI-PHY | MIPI-CSIO data 1 positive | VDD12_MIPI0 |
| | CDSI0D1N | G9 | O | H | MIPI-PHY | MIPI-CSIO data 1 negative | VDD12_MIPI0 |
| | CDSI0D2P | E10 | O | H | MIPI-PHY | MIPI-CSIO data 2 positive | VDD12_MIPI0 |
| | CDSI0D2N | E9 | O | H | MIPI-PHY | MIPI-CSIO data 2 negative | VDD12_MIPI0 |
| CDSI TX1 (10) | CDSI1CP | A7 | O | H | MIPI-PHY | MIPI-CSI1 clock positive | VDD12_MIPI0 |
| | CDSI1CN | B7 | O | H | MIPI-PHY | MIPI-CSI1 clock negative | VDD12_MIPI1 |
| | CDSI1D0P | A9 | O | H | MIPI-PHY | MIPI-CSI1 data 0 positive | VDD12_MIPI1 |
| | CDSI1D0N | B9 | O | H | MIPI-PHY | MIPI-CSI1 data 0 negative | VDD12_MIPI1 |
| | CDSI1D1P | A8 | O | H | MIPI-PHY | MIPI-CSI1 data 1 positive | VDD12_MIPI1 |
| | CDSI1D1N | B8 | O | H | MIPI-PHY | MIPI-CSI1 data 1 negative | VDD12_MIPI1 |
| | CDSI1D2P | A6 | O | H | MIPI-PHY | MIPI-CSI1 data 2 positive | VDD12_MIPI1 |
| | CDSI1D2N | B6 | O | H | MIPI-PHY | MIPI-CSI1 data 2 negative | VDD12_MIPI1 |
| HDMI-RX (9) | CDSI1D3P | A5 | O | H | MIPI-PHY | MIPI-CSI1 data 3 positive | VDD12_MIPI1 |
| | CDSI1D3N | B5 | O | H | MIPI-PHY | MIPI-CSI1 data 3 negative | VDD12_MIPI1 |
| | HDMICP | C1 | I | - | HDMI-PHY | HDMI clock channel positive | VDD33_HDMI |
| | HDMICN | C2 | I | - | HDMI-PHY | HDMI clock channel negative | VDD33_HDMI |
| | HDMID0P | D1 | I | - | HDMI-PHY | HDMI data 0 channel positive | VDD33_HDMI |
| | HDMID0N | D2 | I | - | HDMI-PHY | HDMI data 0 channel negative | VDD33_HDMI |
| | HDMID1P | E1 | I | - | HDMI-PHY | HDMI data 1 channel positive | VDD33_HDMI |
| | HDMID1N | E2 | I | - | HDMI-PHY | HDMI data 1 channel negative | VDD33_HDMI |
| DDC (2) | HDMID2P | F1 | I | - | HDMI-PHY | HDMI data 2 channel positive | VDD33_HDMI |
| | HDMID2N | F2 | I | - | HDMI-PHY | HDMI data 2 channel negative | VDD33_HDMI |
| CEC(1) | REXT | A1 | I | - | HDMI-PHY | External reference resistor (Connect with 2 kΩ to VDD33HDMI) | VDD33_HDMI |
| | CEC | A2 | IO | - | Sch/OD | CEC signal | VDDIO33 |
| HPD(2) | DDC_SCL | A3 | IO | - | Sch/5V/OD | DDC I ² C target clock | VDDIO33 |
| | DDC_SDA | B3 | IO | - | Sch/5V/OD | DDC I ² C target data | VDDIO33 |
| Audio (7) | HPDI | A4 | I | - | 5V | 5V power input | VDDIO33 |
| | HPDO | B4 | O | L | N | Hot plug detect output | VDDIO33 |
| | A_SCK | K7 | O | L | N | I ² S/TDM bit clock signal | VDDIO18 |
| | A_WFS | K5 | O | L | N | I ² S word clock TDM frame sync signal | VDDIO18 |
| | A_SD3 | J5 | O | L | N | I ² S data signal bit3 | VDDIO18 |
| | A_SD2 | J6 | O | L | N | I ² S data signal bit2 | VDDIO18 |
| | A_SD1 | J8 | O | L | N | I ² S data signal bit1 | VDDIO18 |
| IR(1) | A_SD0 | J9 | O | L | N | I ² S data signal bit0 TDM data signal | VDDIO18 |
| | A_OSK | J4 | O | L | N | Audio Over Sampling Clock | VDDIO18 |
| I ² C(2) | IR | G6 | I | - | N | InfraRed signal (Fix low externally, if not used) | VDDIO18 |
| | I ² C_SCL | K4 | IO | - | Sch/OD | I ² C target clock | VDDIO18 |
| | I ² C_SDA | K3 | IO | - | Sch/OD | I ² C target data | VDDIO18 |

| Group | Pin Name | Ball | I/O | Init (O) | Type (Note 1) | Function | Voltage Supply |
|---------------|-------------|--|-----|----------|---------------|--|----------------|
| Audio PLL (4) | BIASDA | J1 | O | L | PLL | Audio PLL BIAS signal Connect to AVSS through 0.1 μF when not used | VDDIO33 |
| | DAOUT | J2 | O | H | PLL | Audio PLL Clock Reference output clock Please leave open when not used | VDDIO33 |
| | PCKIN | K1 | I | - | PLL | Audio PLL Reference Input clock Connect to AVSS through 0.1 μF when not used | VDDIO33 |
| | PFIL | K2 | O | L | PLL | Audio PLL Low Pass Filter signal Connect to AVSS through 0.1 μF when not used | VDDIO33 |
| POWER (10) | VDDC11 | C10 K6 | - | - | Power | 1.1 V Internal core power supply | - |
| | VDDIO18 | J7 | - | - | Power | 1.8 V IO power supply | - |
| | VDDIO33 | H2 | - | - | Power | 3.3 V IO power supply | - |
| | VDD33_HDMI | B1 G1 | - | - | Power | HDMI Phy 3.3 V power supply | - |
| | VDD11_HDMI | B2 G2 | - | - | Power | HDMI Phy 1.1 V power supply | - |
| | VDD12_MIPI0 | J10 | - | - | Power | MIPI CSI2 1.2 V power supply for link0 | - |
| | VDD12_MIPI1 | B10 | - | - | Power | MIPI CSI2 1.2 V power supply for link1 | - |
| Ground (18) | VSS | A10 C9 D4 D5 D6 D7 E4 E5 E6 E7 F4 F5 F6 F7 G4 G7 H1 K10 | - | - | - | Ground | - |

Total 80 pins

Note 1: Descriptions mean below.

- N: Normal digital I/O
- Sch: Schmitt trigger input
- 5 V: 5 V tolerant input
- OD: Open drain

Note 2: Pull-Up to select 0x1F for I²C Target address

Pull-Down to select 0x0F for I²C Target address

Please consult a technical support representative before board design to determine whether pull-up or pull-down with external resistors.

2.1. TC358841XBG 80-Pin Count Summary

Table 2.2 BGA80 Pin Count Summary

| Group Name | Pin Count | Notes |
|------------------|-----------|-------------------|
| System | 4 | - |
| CDSI TX0 | 10 | - |
| CDSI TX1 | 10 | - |
| HDMI-RX | 9 | - |
| DDC | 2 | - |
| CEC | 1 | - |
| Audio | 7 | - |
| I ² C | 2 | - |
| IR | 1 | - |
| HPD | 2 | - |
| Audio PLL | 4 | - |
| POWER | 10 | IO, Core |
| Ground | 18 | IO, Core, Analog |
| TOTAL Pin Count | 80 | Func 52 + (10+18) |

2.2. Pin Layout

Top view

| | 1 | 2 | 3 | 4 | 5 | 6 | 7 | 8 | 9 | 10 |
|---|------------------|------------------|---------------|---------------|---------------|---------------|---------------|---------------|---------------|--------------------|
| A | A1 REXT | A2 CEC | A3 DDC_SCL | A4 HPDI | A5 CDS1D3P | A6 CDS1D2P | A7 CDS1CP | A8 CDS1D1P | A9 CDS1D0P | A10 VSS |
| B | B1 VDD33_HDMI | B2 VDD11_HDMI | B3 DDC_SDA | B4 HPDO | B5 CDS1D3N | B6 CDS1D2N | B7 CDS1CN | B8 CDS1D1N | B9 CDS1D0N | B10 VDD12_MIPI1 |
| C | C1 HDMICP | C2 HDMICN | C3 No ball | C4 No ball | C5 No ball | C6 No ball | C7 No ball | C8 No ball | C9 VSS | C10 VDDC11 |
| D | D1 HDMID0P | D2 HDMID0N | D3 No ball | D4 VSS | D5 VSS | D6 VSS | D7 VSS | D8 No ball | D9 CDS1D3N | D10 CDS1D3P |
| E | E1 HDMID1P | E2 HDMID1N | E3 No ball | E4 VSS | E5 VSS | E6 VSS | E7 VSS | E8 No ball | E9 CDS1D2N | E10 CDS1D2P |
| F | F1 HDMID2P | F2 HDMID2N | F3 No ball | F4 VSS | F5 VSS | F6 VSS | F7 VSS | F8 No ball | F9 CDS1D1N | F10 CDS1D1P |
| G | G1 VDD33_HDMI | G2 VDD11_HDMI | G3 No ball | G4 VSS | G5 TEST | G6 IR | G7 VSS | G8 No ball | G9 CDS1D0N | G10 CDS1D0P |
| H | H1 VSS | H2 VDDIO33 | H3 No ball | H4 No ball | H5 No ball | H6 No ball | H7 No ball | H8 No ball | H9 CDS1D0N | H10 CDS1D0P |
| J | J1 BIASDA | J2 DAOUT | J3 INT | J4 A_OSCK | J5 A_SD3 | J6 A_SD2 | J7 VDDIO18 | J8 A_SD1 | J9 A_SD0 | J10 VDD12_MIPI0 |
| K | K1 PCKIN | K2 PFIL | K3 I2C_SDA | K4 I2C_SCL | K5 A_WFS | K6 VDDC11 | K7 A_SCK | K8 RESETN | K9 REFCLK | K10 VSS |

Figure 2.1 TC358841XBG 80-Pin Layout (Top View)

3. Package

The 80-pin package for TC358841XBG is described in the figures below.

(Unit: mm)

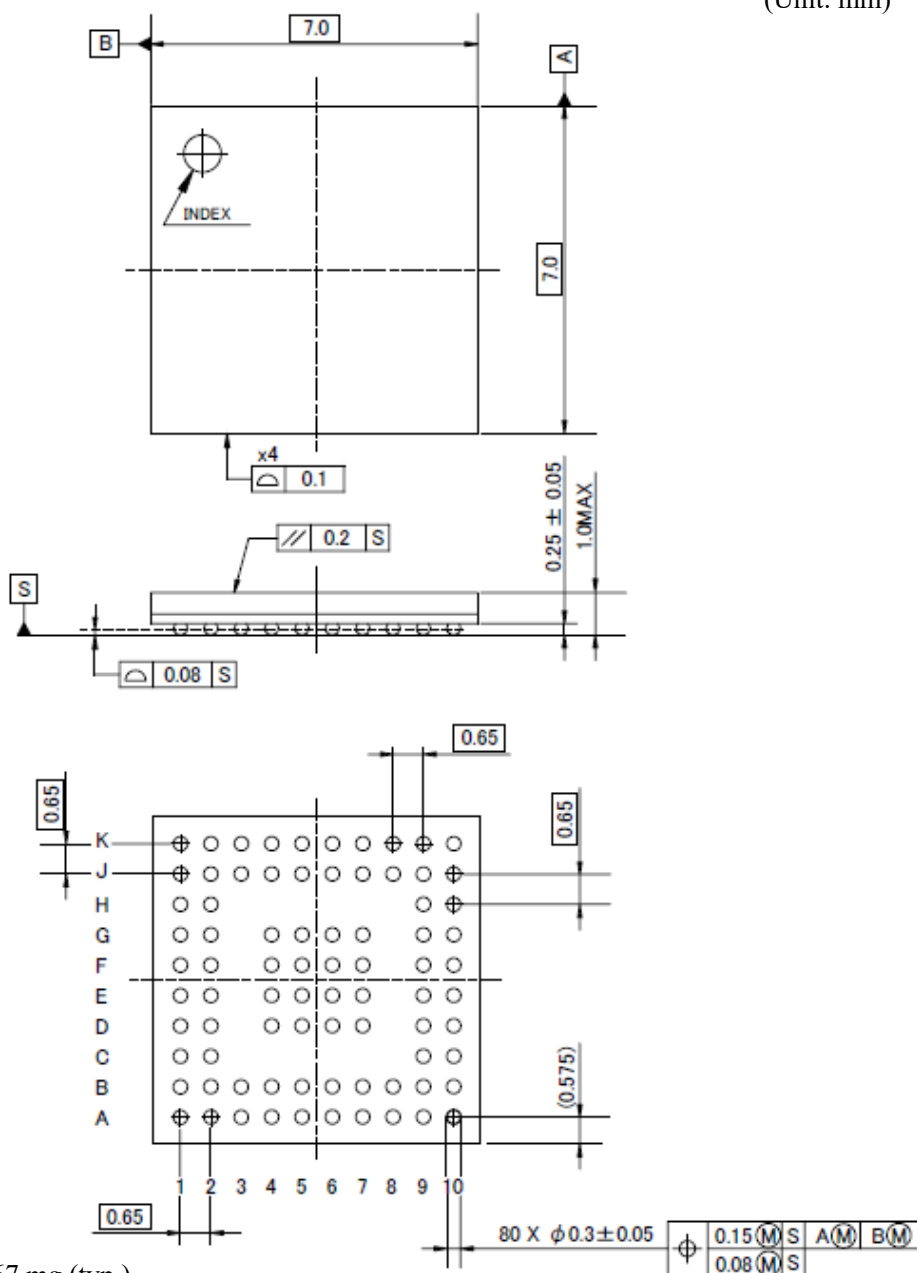

Figure 3.1 TC358841XBG package (P-VFBGA80-0707-0.65-001)

The mechanical dimension of BGA80 package is listed below.

Table 3.1 Mechanical Dimension

| Package | Solder Ball Pitch | Solder Ball Height | Package Dimension | Package Height |
|---------|-------------------|--------------------|---------------------------|----------------|
| 80-Pin | 0.65 mm | 0.25 mm | 7.0 × 7.0 mm ² | 1.0 mm |

4. Electrical Characteristics

4.1. Absolute Maximum Ratings

VSS= 0 V reference

| Item | Symbol | Rating | Unit |
|---------------------------------------|----------------------|--|------|
| Supply voltage (1.8 V - Digital IO) | VDDIO18 | -0.3 to +3.9 | V |
| Supply voltage (3.3 V - Digital IO) | VDDIO33 | -0.3 to +3.9 | V |
| Supply voltage (1.1 V - Digital Core) | VDDC11 | -0.3 to +1.8 | V |
| Supply voltage (1.2 V - MIPI CSI PHY) | VDD12_MIPI | -0.3 to +1.8 | V |
| Supply voltage (3.3 V - HDMIRX Phy) | VDD33_HDMI | -0.3 to +3.9 | V |
| Supply voltage (1.1 V - HDMIRX Phy) | VDD11_HDMI | -0.3 to +1.8 | V |
| Input voltage (CSI IO) | V _{IN_CSI} | -0.3 to VDD12_MIPI+0.3 | V |
| Output voltage (CSI IO) | V _{OUT_CSI} | -0.3 to VDD12_MIPI+0.3 | V |
| Input voltage (Digital IO) | V _{IN_IO} | -0.3 to VDDIO18+0.3 -0.3 to VDDIO33+0.3 | V |
| Output voltage (Digital IO) | V _{OUT_IO} | -0.3 to VDDIO18+0.3 | V |
| Junction temperature | T _j | 125 | °C |
| Storage temperature | T _{stg} | -40 to +125 | °C |

4.2. Operating Condition

VSS= 0 V reference

| Item | Symbol | Min | Typ. | Max | Unit |
|--|----------------------------|-------|------|-------|------|
| Supply voltage (1.8 V - Digital IO) | VDDIO18 (Note) | 1.65 | 1.8 | 1.95 | V |
| Supply voltage (3.3 V - Digital IO) | VDDIO33 | 3.0 | 3.3 | 3.6 | V |
| Supply voltage (1.1 V - Digital Core) | VDDC11 | 1.1 | 1.15 | 1.2 | V |
| Supply voltage (3.3 V - HDMIRX PHY) | VDD33_HDMI | 3.135 | 3.3 | 3.465 | V |
| Supply voltage (1.1 V - HDMIRX PHY) | VDD11_HDMI | 1.1 | 1.15 | 1.2 | V |
| Supply voltage (1.2 V - MIPI CSI PHY) | VDD12_MIPI0 VDD12_MIPI1 | 1.1 | 1.2 | 1.3 | V |
| Operating temperature (ambient temperature with voltage applied) | T _a | -30 | +25 | +70 | °C |

Note: VDDIO18 can be used at 1.8 V or 3.3 V.

4.3. DC Electrical Specification

Standard IO

| Item | Symbol | Min | Max | Unit |
|--|--------------------|-----------------------|-----------------------|------|
| Input voltage, High level input (Note 1) | V _{IH} | 0.70 VDDIO18 (Note 2) | VDDIO18 (Note 2) | V |
| | | 0.70 VDDIO18 (Note 3) | VDDIO18 (Note 3) | |
| | | 0.70 VDDIO33 (Note 4) | VDDIO33 (Note 4) | |
| Input voltage, Low level input (Note 1) | V _{IL} | 0 | 0.30 VDDIO18 (Note 2) | V |
| | | | 0.25 VDDIO18 (Note 3) | |
| | | | 0.25 VDDIO33 (Note 4) | |
| Input voltage High level CMOS Schmitt Trigger (Note 1) | V _{IHS} | 0.70 VDDIO18 (Note 2) | VDDIO18 (Note 2) | V |
| | | 0.70 VDDIO18 (Note 3) | VDDIO18 (Note 3) | |
| | | 0.70 VDDIO33 (Note 4) | VDDIO33 (Note 4) | |
| Input voltage Low level CMOS Schmitt Trigger (Note 1) | V _{ILS} | 0 | 0.30 VDDIO18 (Note 2) | V |
| | | | 0.25 VDDIO18 (Note 3) | |
| | | | 0.25 VDDIO33 (Note 4) | |
| Input leak current, High level (Condition: V _{IN} = +VDDIO, VDDIO = 3.6 V) | I _{I LH1} | -10 | 10 | μA |
| Input leak current, Low level (Condition: V _{IN} = 0V, VDDIO = 3.6 V) | I _{I LL1} | -10 | 10 | μA |

Note 1: Each power source is operating within recommended operation condition.

Note 2: For IOs related to VDDIO18 and operated at 1.8 V range.

Note 3: For IOs related to VDDIO18 and operated at 3.3 V range.

Note 4: For IOs related to VDDIO33.

HDMI DDC Target IO (DDC_SDA, DDC_SCL terminal)

| Item | Symbol | Min | Max | Unit |
|--|------------------|-----|------|------|
| Input voltage, High level input | V _{IH} | 3.1 | 5.25 | V |
| Input voltage, Low level input | V _{IL} | 0 | 1.7 | V |
| Output voltage Low level (I _{OL} = 8 mA) | V _{OL} | - | 0.4 | V |
| Input leak current, High level (V _{IN} = VDDIO33) | I _{I H} | -10 | 10 | μA |
| Input leak current, Low level (V _{IN} = VSS) | I _{I L} | -10 | 10 | μA |

HDMI DDC 5 V input (HPDI terminal)

| Item | Symbol | Min | Max | Unit |
|---|------------------|-------------|-------------|------|
| Input voltage, High level input | V _{IH} | 0.8 VDDIO33 | 5.25 | V |
| Input voltage, Low level input | V _{IL} | 0 | 0.3 VDDIO33 | V |
| Input leak current, High level (V _{IN} = VDDIO33) | I _{I H} | -10 | 10 | μA |
| Input leak current, Low level (V _{IN} = VSS) | I _{I L} | -10 | 10 | μA |

HDMI HPD output (HPDO terminal)

| Item | Symbol | Min | Max | Unit |
|---|--------|-------------|-----|------|
| Output voltage High level (IOH = -4 mA) | VOH | VDDIO33-0.6 | - | V |
| Output voltage Low level (IOL = 4 mA) | VOL | - | 0.4 | V |

HDMI CEC IO (CEC terminal)

| Item | Symbol | Min | Max | Unit |
|--|--------|-----|---------|------|
| Input voltage, High level input | VIH | 2 | VDDIO33 | V |
| Input voltage, Low level input | VIL | 0 | 0.8 | V |
| Output voltage Low level (IOL = 8 mA) | VOL | - | 0.4 | V |
| Input leak current, High level (VIN = VDDIO33) | IiH | -10 | 10 | μA |
| Input leak current, Low level (VIN = VSS) | IiL | -10 | 10 | μA |

I2C IO (I2C_SDA, I2C_SCL terminal)

| Item | Symbol | Min | Max | Unit |
|---|--------|-------------|-------------|------|
| Input voltage, High level input | VIH | 0.7 VDDIO18 | VDDIO18 | V |
| Input voltage, Low level input | VIL | 0 | 0.3 VDDIO18 | V |
| Output voltage Low level (VDDIO18 used at 1.8 V range, IOL = 3 mA) | VOL | - | 0.2 VDDIO18 | V |
| Output voltage Low level (VDDIO18 used at 3.3 V range, IOL = 3 mA) | | - | 0.4 | V |

Audio output (A_SCK, A_WFS, A_SD3, A_SD2, A_SD1, A_SD0, A_OSCK terminal)

| Item | Symbol | Min | Max | Unit |
|---|--------|--------------|------|------|
| Output voltage High level (VDDIO18 used at 1.8 V range, IOH = -4 mA) | VOH | VDDIO18-0.45 | - | V |
| Output voltage High level (VDDIO18 used at 3.3 V range, IOH = -4 mA) | | VDDIO18-0.6 | - | V |
| Output voltage Low level (VDDIO18 used at 1.8 V range, IOL = 4 mA) | VOL | - | 0.45 | V |
| Output voltage Low level (VDDIO18 used at 3.3 V range, IOL = 4 mA) | | - | 0.4 | V |

INT output (INT terminal)

| Item | Symbol | Min | Max | Unit |
|---|--------|--------------|------|------|
| Output voltage High level (VDDIO18 used at 1.8 V range, IOH = -2 mA) | VOH | VDDIO18-0.45 | - | V |
| Output voltage High level (VDDIO18 used at 3.3 V range, IOH = -2 mA) | | VDDIO18-0.6 | - | V |
| Output voltage Low level (VDDIO18 used at 1.8 V range, IOL = 2 mA) | VOL | - | 0.45 | V |
| Output voltage Low level (VDDIO18 used at 3.3 V range, IOL = 2 mA) | | - | 0.4 | V |

5. External Circuit Recommendation

5.1. I²C Target address definition

INT terminal is multiplexed with configuring function of I²C Target address. During RESETN asserted, INT becomes input and detects the polarity. After RESETN deasserted it becomes INT function (output) automatically. Pull up or pull down this terminal by 10 kΩ resistor externally.

If pulled up, then I²C Target address becomes 0x1F

If pulled down then I²C Target address becomes 0x0F

5.2. DDC_SDA/DDC_SCL

DDC_SDA and DDC_SCL are pulled up to +5 V power line and +5 V power line is also pulled down for DDC_SDA and DDC_SDL to be fixed low when +5 V power is disabled.

Below figure illustrates example DDC interface connections.

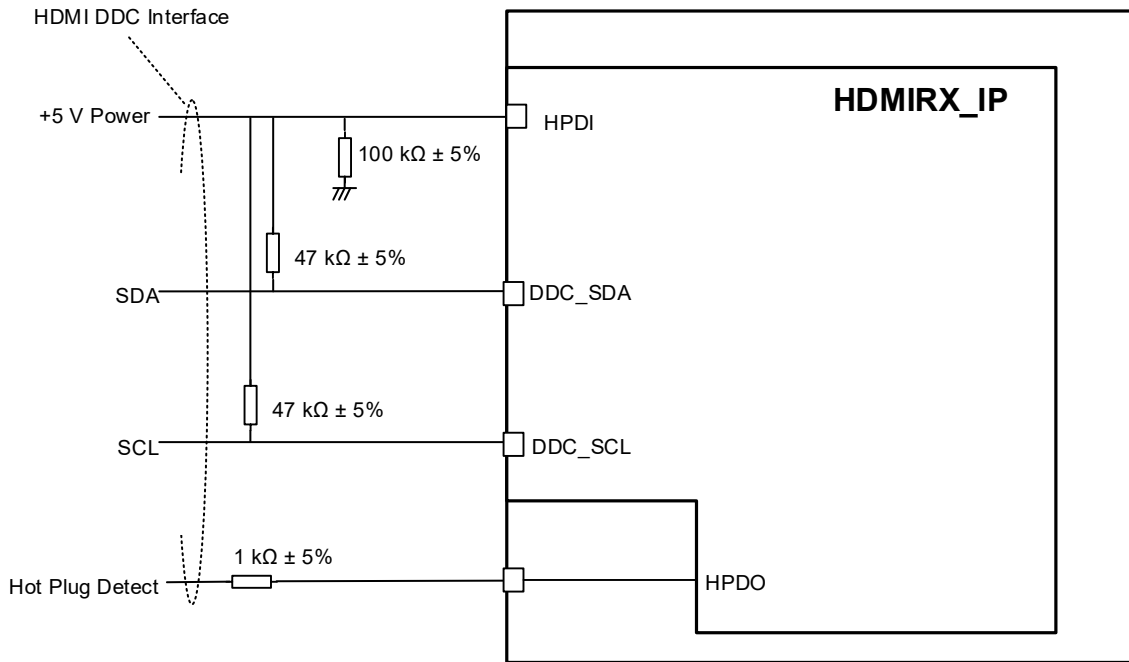

Figure 5.1 Example of DDC I/F Connection

The automatic adjustment function of terminus resistance is attached to HDMI-RX.
 Therefore, connect $2\text{ k}\Omega \pm 1\%$ of reference resistance between VDD33_HDMI and REXT.

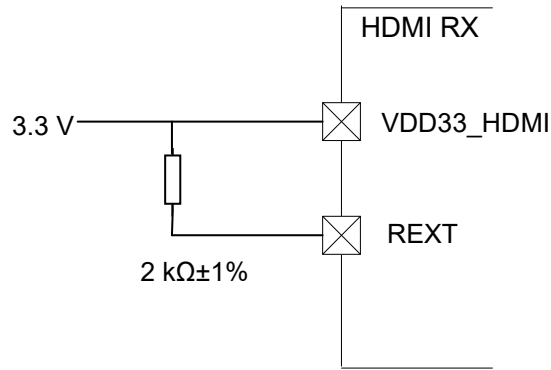

Figure 5.2 Connection of REXT resistance

5.3. Audio PLL

The Audio PLL external terminal connections used in the Audio clock generation are shown in the Figure below.
 In DAOUT output (PLL input), a low pass filter is installed in the LSI external area.
 In addition, a low pass filter for cutting unnecessary components in phase comparator output in the PLL is also installed in the LSI external area.

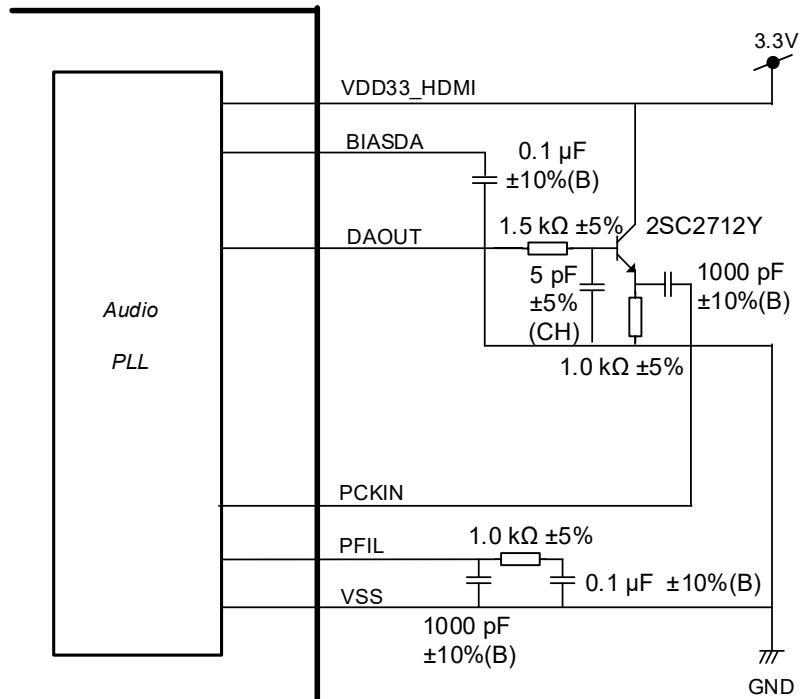

Figure 5.3 Audio Clock External LPF circuit block diagram

5.4. Recommended power supply circuit

Since the ESD protection diode is attached to the TMDS input pin between a power supply/GND, current may flow backwards HDMI-RX from source apparatus at the time of power supply OFF.

And also VDD33_HDMI power supply should be isolated from another 3.3 V power supplies because this backward current also damages them. Below figure is recommend attaching a back flow prevention circuit.

Case (1) External switch circuit

Attach the adverse current prevention switch from a TMDS differential signal.

Since reverse current also gives damage to VDDIO33, this switch shall separate VDD33_HDMI and VDDIO33.

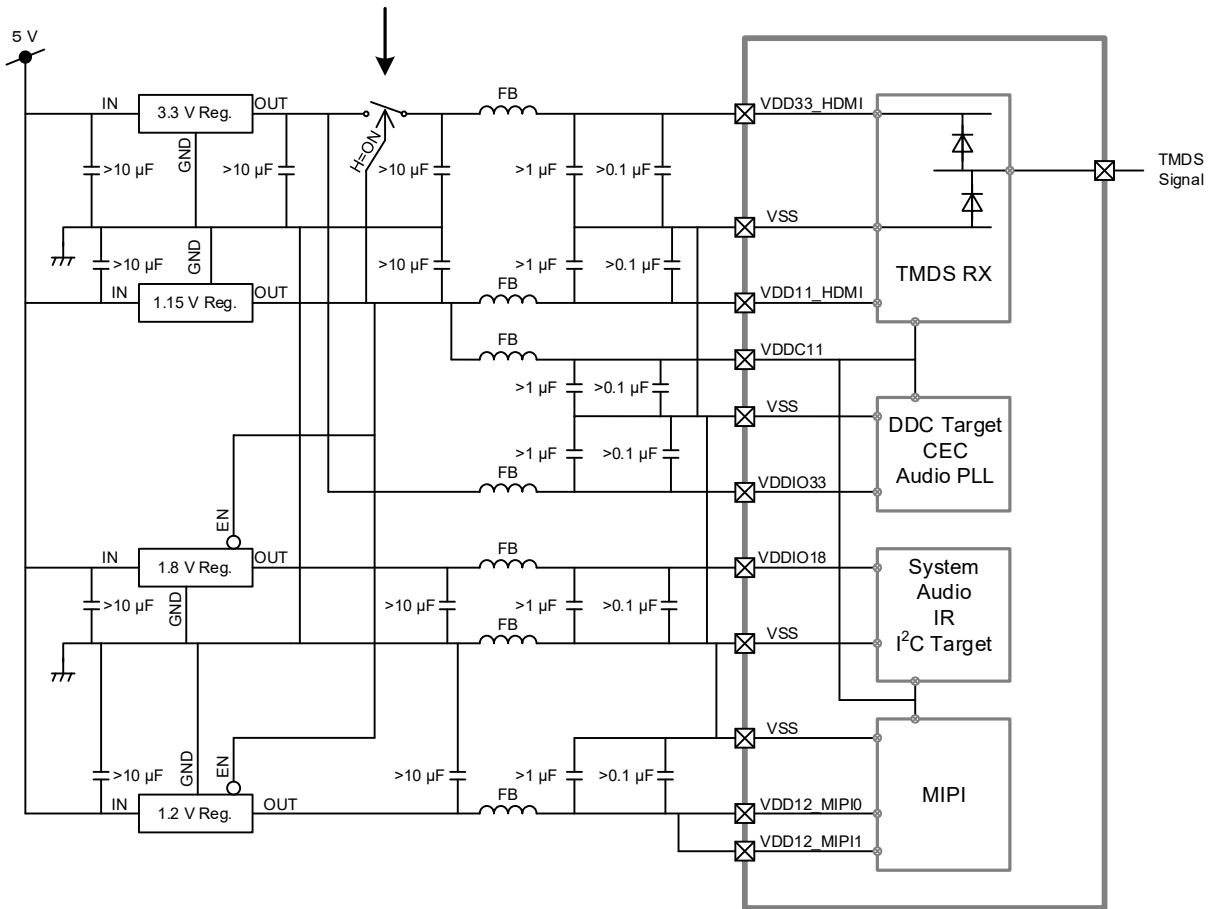

All TC358841 VSSs should be separated at AC level from regulators' VSS with FB(ferrite bead) or another method to attenuate EMI.

Figure 5.4 Recommended power supply circuit with external switch

Case (2) Regulator with reverse current protection
 Apply a current protection regulator to VDD33_HDMI.

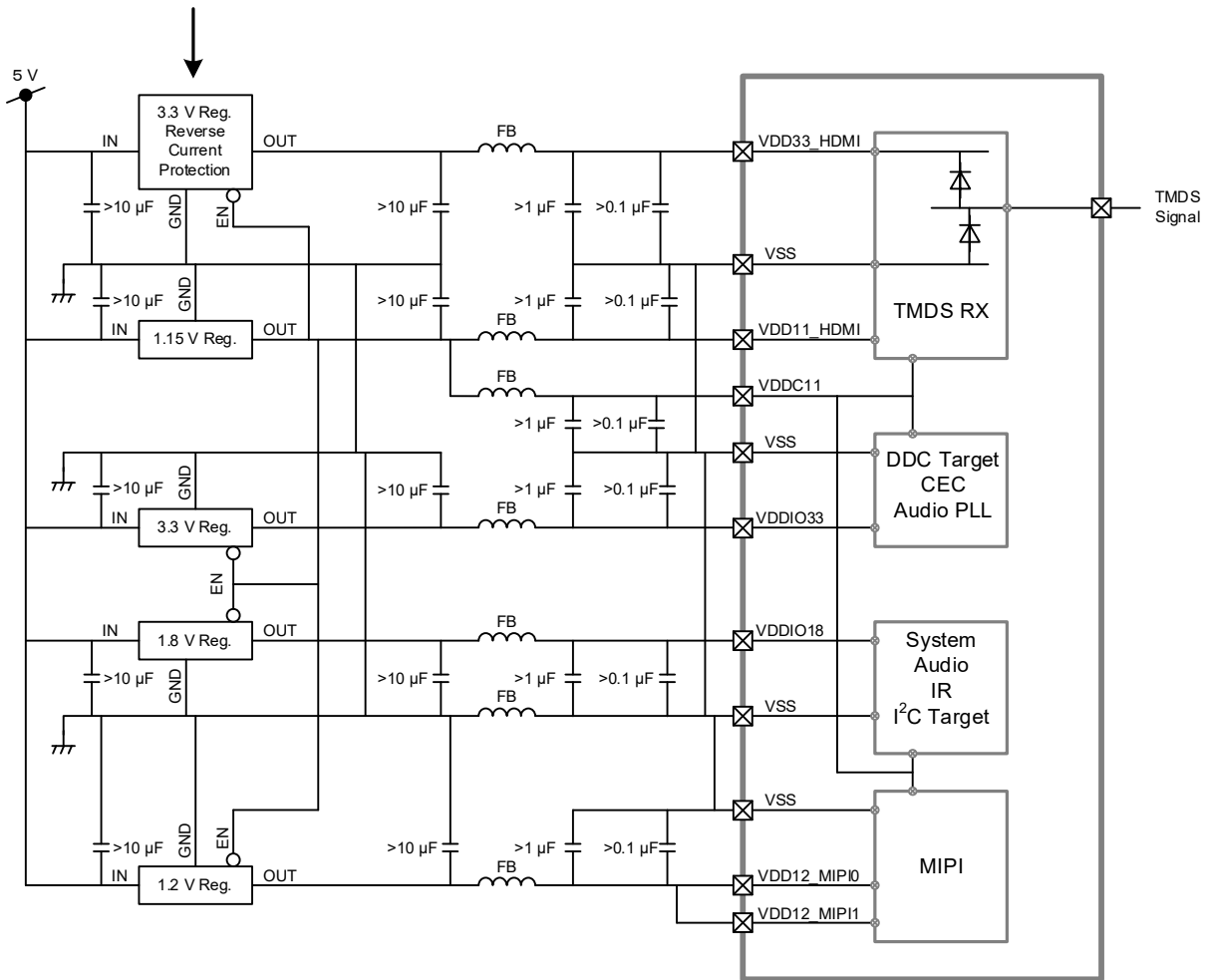

All TC358841 VSSs should be separated at AC level from regulators' VSS with FB(ferrite bead) or another method to attenuate EMI.

Figure 5.5 Recommended power supply circuit with current protection regulator

Case (3) Use of VDDIO18 at 3.3 V range

If VDDIO is applied at 3.3 V range, Common regulation is available among VDD33_HDMI, VDIO33 and VDDIO18.

Attach the adverse current prevention switch from a TMD5 differential signal.

Since reverse current also gives damage to VDDIO33 and VDDIO18, this switch shall separate VDD33_HDMI and VDDIO33/VDDIO18.

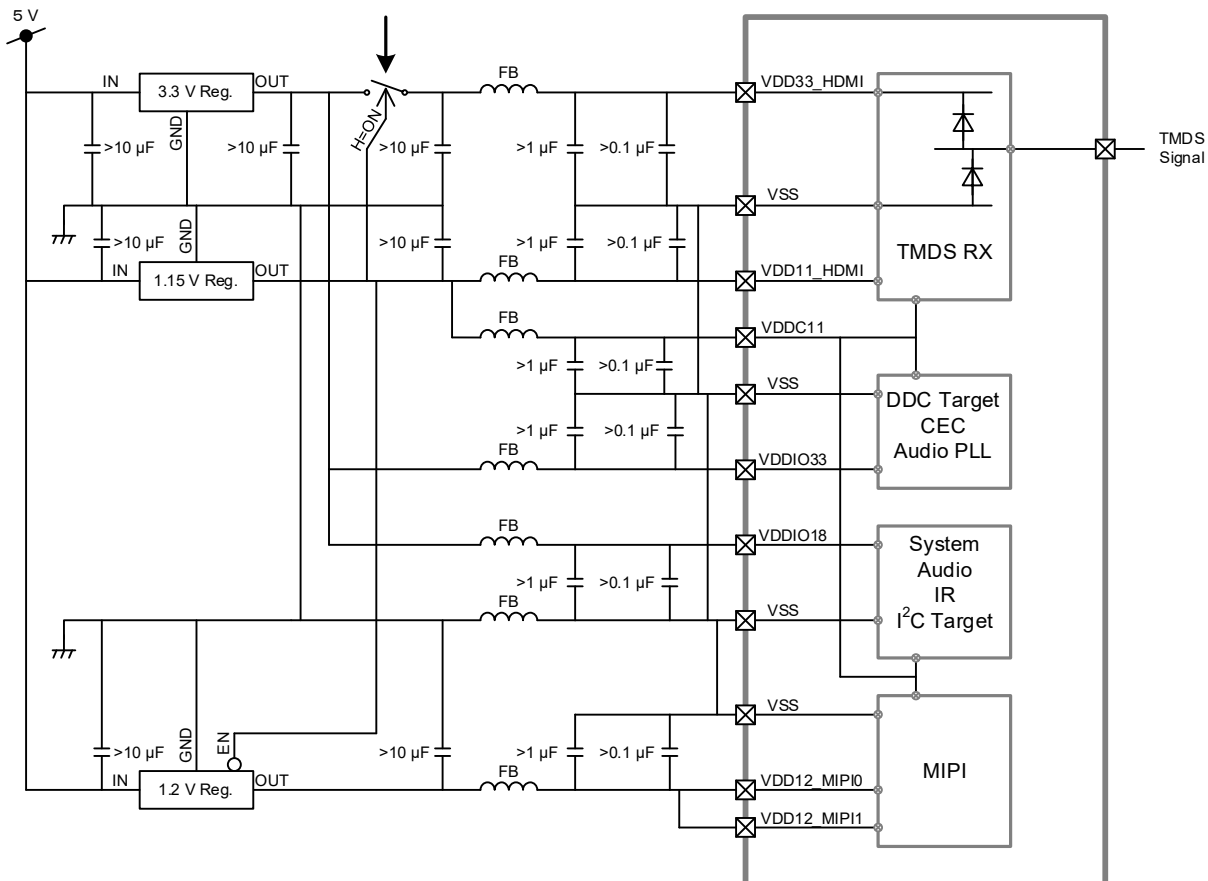

All TC358841 VSSs should be separated at AC level from regulators' VSS with FB(ferrite bead) or another method to attenuate EMI.

Figure 5.6 Recommended power supply circuit at VDDIO18 = 3.3 V

6. Revision History

Table 6.1 Revision History

| Revision | Date | Description |
|-----------------|-------------|--|
| 1.00 | 2023-06-07 | New |
| 1.10 | 2026-04-14 | Updated the terms "Master/Slave" to "Controller/Target". Corrected typos. Revised the last page "RESTRICTIONS ON PRODUCT USE". |

RESTRICTIONS ON PRODUCT USE

Toshiba Corporation and its subsidiaries and affiliates are collectively referred to as "TOSHIBA". Hardware, software and systems described in this document are collectively referred to as "Product".

- TOSHIBA reserves the right to make changes to the information in this document and related Product without notice.
- This document and any information herein may not be reproduced without prior written permission from TOSHIBA. Even with TOSHIBA's written permission, reproduction is permissible only if reproduction is without alteration/omission.
- Though TOSHIBA works continually to improve Product's quality and reliability, Product can malfunction or fail. Customers are responsible for complying with safety standards and for providing adequate designs and safeguards for their hardware, software and systems which minimize risk and avoid situations in which a malfunction or failure of Product could cause loss of human life, bodily injury or damage to property, including data loss or corruption. Before customers use the Product, create designs including the Product, or incorporate the Product into their own applications, customers must also refer to and comply with (a) the latest versions of all relevant TOSHIBA information, including without limitation, this document, the specifications, the data sheets and application notes for Product and the precautions and conditions set forth in the "TOSHIBA Semiconductor Reliability Handbook" and (b) the instructions for the application with which the Product will be used with or for. Customers are solely responsible for all aspects of their own product design or applications, including but not limited to (a) determining the appropriateness of the use of this Product in such design or applications; (b) evaluating and determining the applicability of any information contained in this document, or in charts, diagrams, programs, algorithms, sample application circuits, or any other referenced documents; and (c) validating all operating parameters for such designs and applications. **TOSHIBA ASSUMES NO LIABILITY FOR CUSTOMERS' PRODUCT DESIGN OR APPLICATIONS.**
- **PRODUCT IS NEITHER INTENDED NOR WARRANTED FOR USE IN EQUIPMENTS OR SYSTEMS THAT REQUIRE EXTRAORDINARILY HIGH LEVELS OF QUALITY AND/OR RELIABILITY, AND/OR A MALFUNCTION OR FAILURE OF WHICH MAY CAUSE LOSS OF HUMAN LIFE, BODILY INJURY, SERIOUS PROPERTY DAMAGE AND/OR SERIOUS PUBLIC IMPACT ("UNINTENDED USE").** Except for specific applications as expressly stated in this document, Unintended Use includes, without limitation, equipment used in nuclear facilities, equipment used in the aerospace industry, Class 3 medical devices, equipment used for automobiles, and military vehicles and munitions. **IF YOU USE PRODUCT FOR UNINTENDED USE, TOSHIBA ASSUMES NO LIABILITY FOR PRODUCT.** For details, please contact your TOSHIBA sales representative or contact us via our website.
- Do not disassemble, analyze, reverse-engineer, alter, modify, translate or copy Product, whether in whole or in part.
- Product shall not be used for or incorporated into any products or systems whose manufacture, use, or sale is prohibited under any applicable laws or regulations.
- The information contained herein is presented only as guidance for Product use. No responsibility is assumed by TOSHIBA for any infringement of patents or any other intellectual property rights of third parties that may result from the use of Product. No license to any intellectual property right is granted by this document, whether express or implied, by estoppel or otherwise.
- **ABSENT A WRITTEN SIGNED AGREEMENT, EXCEPT AS PROVIDED IN THE RELEVANT TERMS AND CONDITIONS OF SALE FOR PRODUCT, AND TO THE MAXIMUM EXTENT ALLOWABLE BY LAW, TOSHIBA (1) ASSUMES NO LIABILITY WHATSOEVER, INCLUDING WITHOUT LIMITATION, INDIRECT, CONSEQUENTIAL, SPECIAL, OR INCIDENTAL DAMAGES OR LOSS, INCLUDING WITHOUT LIMITATION, LOSS OF PROFITS, LOSS OF OPPORTUNITIES, BUSINESS INTERRUPTION AND LOSS OF DATA, AND (2) DISCLAIMS ANY AND ALL EXPRESS OR IMPLIED WARRANTIES AND CONDITIONS RELATED TO SALE, USE OF PRODUCT, OR INFORMATION, INCLUDING WARRANTIES OR CONDITIONS OF MERCHANTABILITY, FITNESS FOR A PARTICULAR PURPOSE, ACCURACY OF INFORMATION, OR NONINFRINGEMENT.**
- Do not use or otherwise make available Product or related software or technology for any military purposes, including without limitation, for the design, development, use, stockpiling or manufacturing of nuclear, chemical, or biological weapons or missile technology products (mass destruction weapons). Product and related software and technology may be controlled under the applicable export laws and regulations including, without limitation, the Japanese Foreign Exchange and Foreign Trade Law and the U.S. Export Administration Regulations. Export and re-export of Product or related software or technology are strictly prohibited except in compliance with all applicable export laws and regulations.
- Please contact your TOSHIBA sales representative for details as to environmental matters such as the RoHS compatibility of Product. Please use Product in compliance with all applicable laws and regulations that regulate the inclusion or use of controlled substances, including without limitation, the EU RoHS Directive. **TOSHIBA ASSUMES NO LIABILITY FOR DAMAGES OR LOSSES OCCURRING AS A RESULT OF NONCOMPLIANCE WITH APPLICABLE LAWS AND REGULATIONS.**

