

MOS Linear Integrated Circuit Silicon Monolithic

# TCB001HQ

Maximum Power 45W BTL × 4-ch Audio Power IC

## 1. Description

The TCB001HQ is a four-channel BTL power amplifier for car audio applications.

This IC has a pure complementary P-ch and N-ch DMOS output stage, offering maximum output power (P<sub>OUT MAX</sub>) of 45W.

It includes a standby switch, mute function and various protection features.

## 2. Applications

Power IC developed for car audio applications.

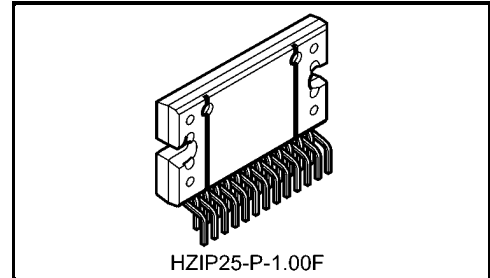

HZIP25-P-1.00F  
Weight: 7.7 g (typ.)

## 3. Features

- High output power, low distortion, and low noise property (for details, refer to the Table 1)
- Built-in various mute functions (low voltage, standby on/off)
- Built-in standby switch (pin4)
- Built-in mute switch (pin22)
- Built-in various detection circuits (output offset voltage, output short, over voltage) (pin25)
- Start stop Cruising corresponded to V<sub>DD</sub>=6V (Engine idle reduction capability)
- Built-in various protection circuits (thermal shut down, over voltage, short to V<sub>DD</sub>, short to GND, and output to output short, prevention of speaker damage)

**Table1 typical Characteristics**  
(Note1,Note2)

Condition	Typ.	Unit
<b>Output power (P<sub>OUT</sub>)</b>		
V <sub>DD</sub> = 15.2 V, JEITA max	45	W
V <sub>DD</sub> = 14.4 V, JEITA max	40	
V <sub>DD</sub> = 14.4 V, THD = 10%	26	
THD = 10%	22	
<b>Total harmonic distortion (THD)</b>		
P <sub>OUT</sub> = 4 W	0.01	%
<b>Output noise voltage (V<sub>NO</sub>) (R<sub>g</sub> = 0 Ω),</b>		
BW = 20 Hz to 20 kHz	45	μV
<b>Operating Supply voltage range (V<sub>DD</sub>)</b>		
R <sub>L</sub> = 4 Ω	6 to 18	V

Note1: Typical test conditions: V<sub>DD</sub> = 13.2 V, f = 1 kHz, R<sub>L</sub> = 4 Ω, G<sub>v</sub> = 26 dB, T<sub>a</sub> = 25°C, unless otherwise specified.

Note2: R<sub>g</sub>: signal source resistance

## 4. Block Diagram

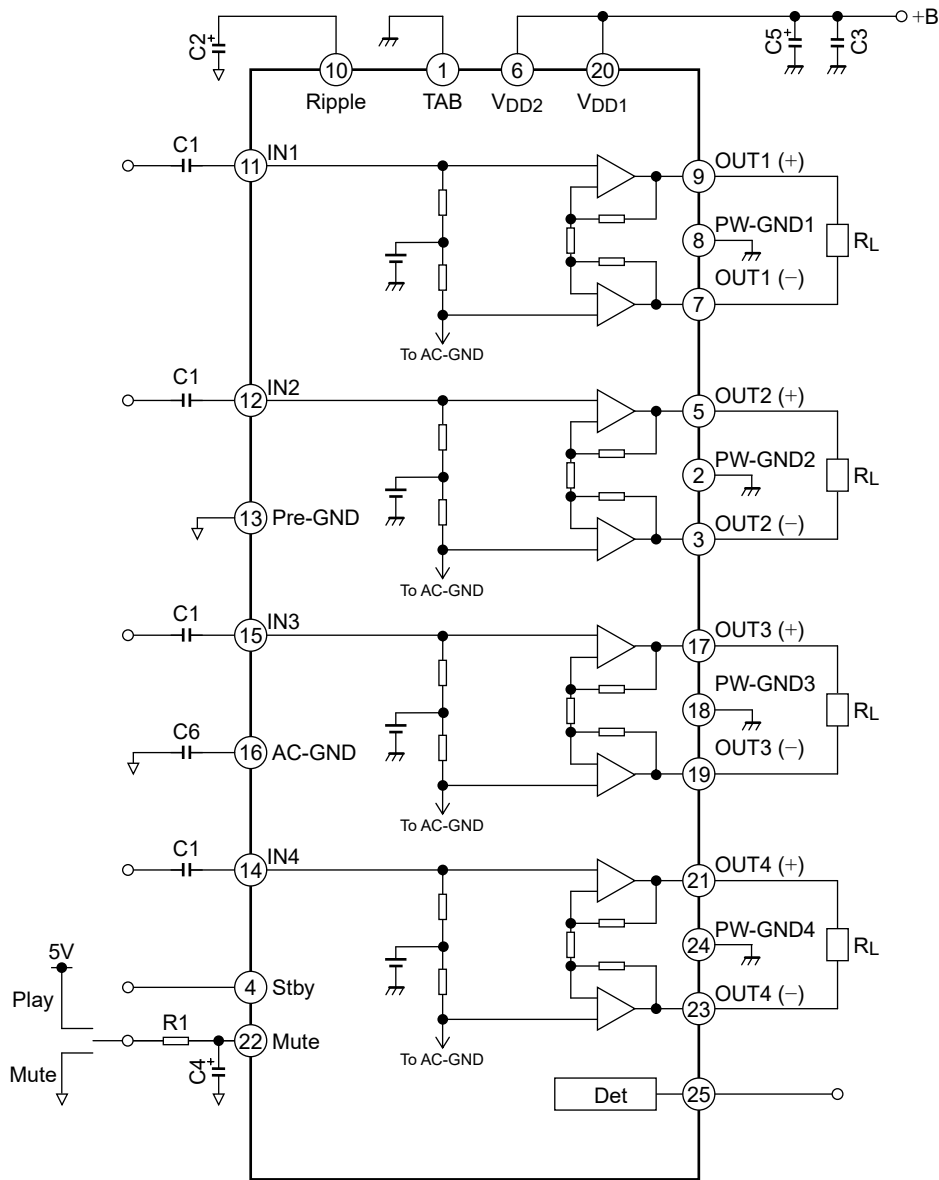

Some of the functional blocks, circuits or constants may be omitted from the block diagram or simplified for explanatory purposes. In the following explanation, a "channel" is a circuit which consists of IN<sub>x</sub>, OUT<sub>x</sub> (+), OUT<sub>x</sub> (-), and PW-GND<sub>x</sub>. (x: 1 to 4).

## 5. Pin Configuration and Function Descriptions

### 5.1 Pin Configuration (top view)

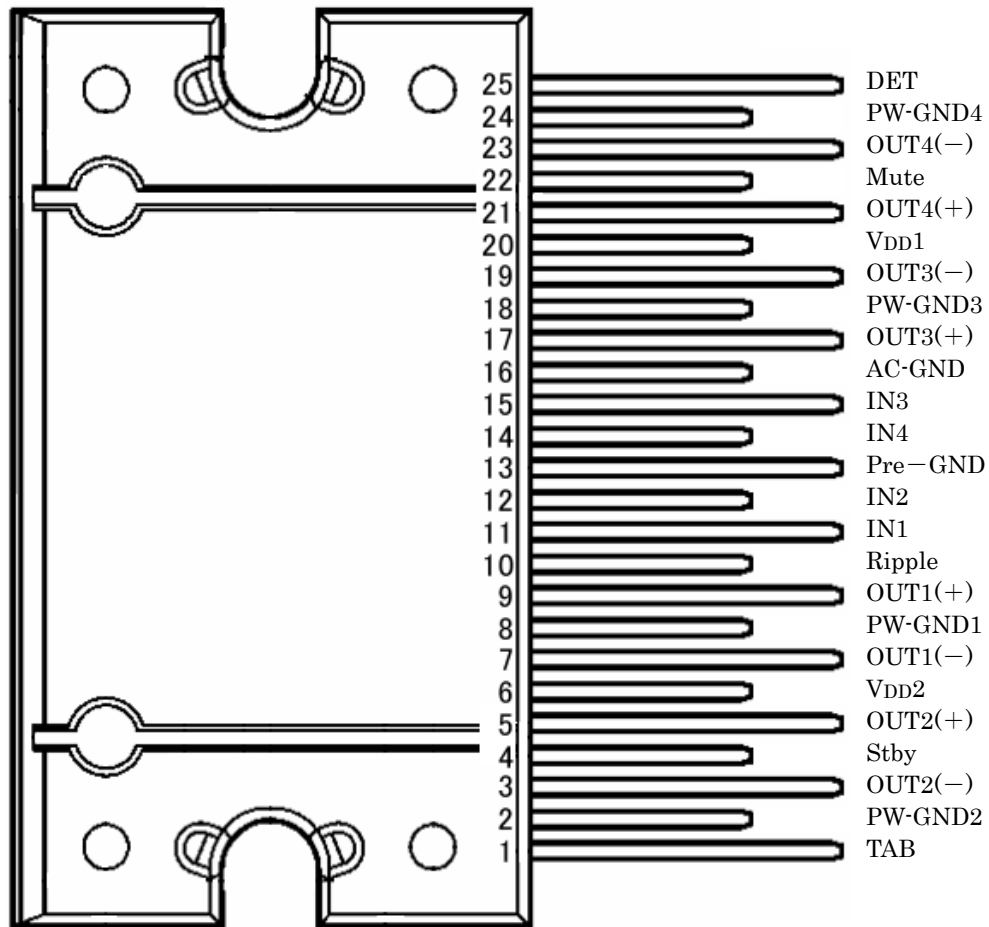

## 5.2 Pin Function Descriptions

Pin	Symbol	I/O	Description
1	TAB	—	TAB (Always connect with GND)
2	PW-GND2	—	Ground for Rear Left output
3	OUT2(-)	OUT	Rear Left output-
4	Stby	V <sub>ST</sub> -IN	Standby voltage input
5	OUT2(+)	OUT	Rear Left output+
6	V <sub>DD</sub> 2	V <sub>DD</sub> -IN	Supply voltage 2
7	OUT1(-)	OUT	Rear Left output+
8	PW-GND1	—	Ground for Front Left output
9	OUT1(+)	OUT	Front Left output-
10	Ripple	—	Ripple voltage
11	IN1	IN	Front Left input
12	IN2	IN	Rear Left input
13	Pre-GND	—	Signal ground
14	IN4	IN	Rear Right input
15	IN3	IN	Front Right input
16	AC-GND	—	Common reference voltage for all input
17	OUT3(+)	OUT	Front Right output+
18	PW-GND3	—	Ground for Front Right output
19	OUT3(-)	OUT	Front Right output-
20	V <sub>DD</sub> 1	V <sub>DD</sub> -IN	Supply voltage 1
21	OUT4(+)	OUT	Rear Right output+
22	Mute	V <sub>mute</sub> IN	Mute voltage input
23	OUT4(-)	OUT	Rear Right output-
24	PW-GND4	—	Ground for Rear Right output
25	DET	(OD) Note1	Offset detector output / short detector / over voltage

Note1 OD: Open drain.

## 6. Detailed Description

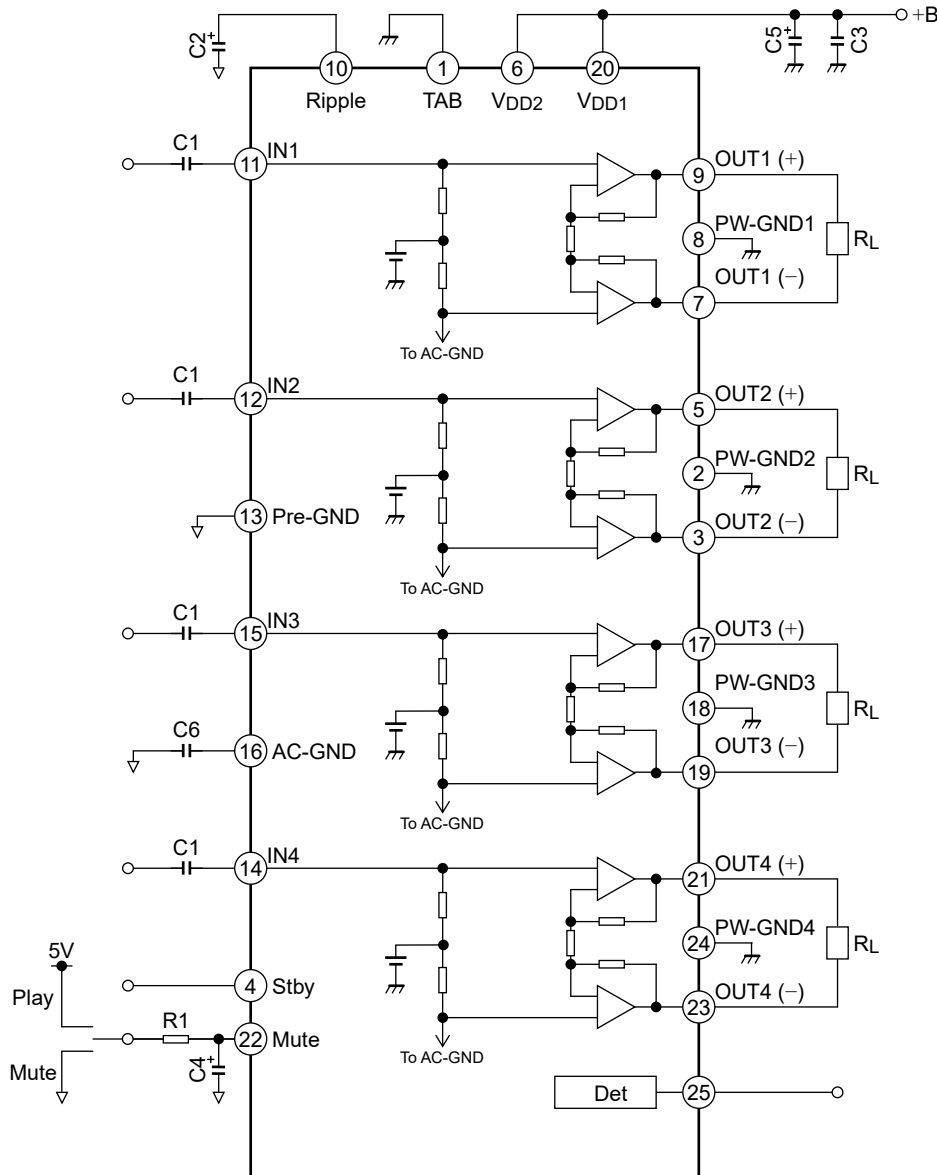

Component Name	Recomm ended Value	Pin	Purpose	Effect (Note1)	
				Lower than Recommended Value	Higher than Recommended Value
C1	0.22 $\mu$ F	INx (x: 1 to 4)	To eliminate DC	Cut-off frequency becomes higher	Cut-off frequency becomes lower
C2	10 $\mu$ F	Ripple	To reduce ripple	Turn on/off time and turn-on diag. cycle shorter	Turn on/off time and turn-on diag. cycle longer
C3	0.1 $\mu$ F	V <sub>DD1</sub> , V <sub>DD2</sub>	To provide sufficient oscillation margin	Reduces noise and provides sufficient oscillation margin	
C4	1 $\mu$ F	Mute	To reduce pop noise(Note2)	High pop noise. Duration until mute function is turned on/off is short.	Low pop noise. Duration until mute function is turned on/off is long.
C5	3900 $\mu$ F	V <sub>DD1</sub> , V <sub>DD2</sub>	Ripple filter	Power supply ripple filtering	
C6	1 $\mu$ F	AC-GND	Common reference voltage for all input	Pop noise is suppressed when C1 : C6 = 1 : 4. (Note3)	
R1	47k $\Omega$	Mute	To reduce pop noise	High pop noise. Duration until mute function is turned on/off is short.	Low pop noise. Duration until mute function is turned on/off is long.

Note1: When the unrecommended value is used, please examine it enough by system evaluation.

Note2: Since “AC-GND” pin is a common reference voltage for all input, this product needs to set the ratio of an input capacitance (C1) and the AC-GND capacitance (C6) to 1 : 4.

Note3: Please use the low leak current apacitor for C1 and C6.

## 7. Standby Switch

The power supply can be turned on or off via pin 4 (Stby). The threshold voltage of pin 4 is below table. The power supply current is about 0.01  $\mu\text{A}$  (typ.) in the standby state.

**Table1 Standby Control Voltage ( $V_{\text{stby}}$ )**

Stby	Power	$V_{\text{stby}}$ (V)
ON	OFF	0 to 0.8
OFF	ON	2.2 to $V_{\text{DD}}$

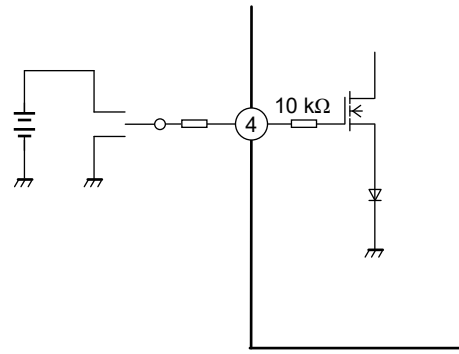

Check the pop levels when the time constant of pin 4 is changed.

### Benefits of the Standby Switch

- (1)  $V_{\text{DD}}$  can be directly turned on or off by a microcontroller, eliminating the need for a switching relay.
- (2) Since the control current is minuscule, a low-current-rated switching relay can be used.

4

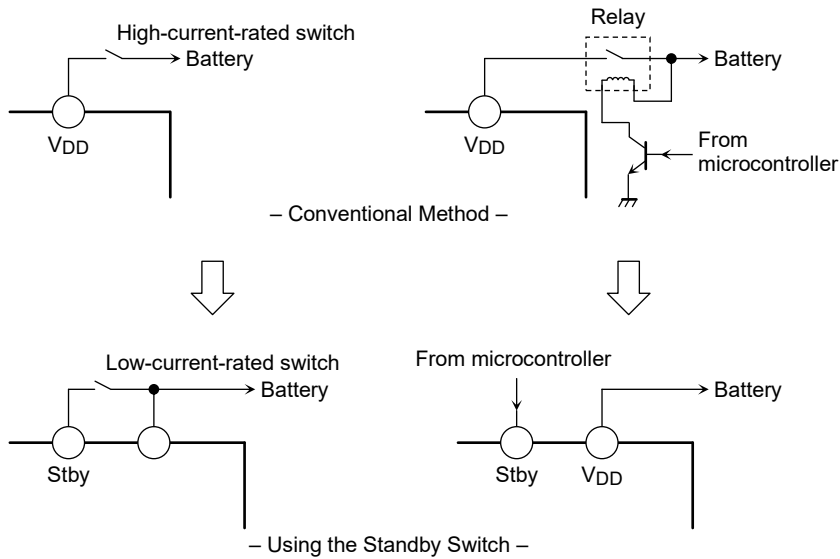

**Figure 2 Standby Switch**

## 8. Mute switch

The audio mute switch is enabled by setting pin 22 Low. R1 and C4 determine the time constant of the mute. The time constant affects pop noise generated when power or the mute is turned on or off; thus, it must be determined on a per-application basis. And this terminal is designed on the control voltage of 5 V. The value of the external pull-up resistor is determined, based on pop noise value.

For example, when the control voltage is changed from 5 V to 3.3 V, the pull-up resistor should be:  
 $3.3 \text{ V} / 5 \text{ V} \times 47 \text{ k}\Omega = 31 \text{ k}\Omega$

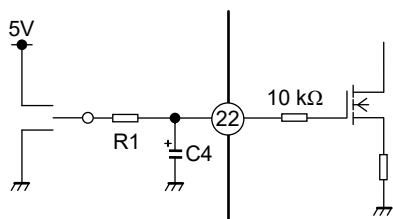

Figure 3 Mute Function

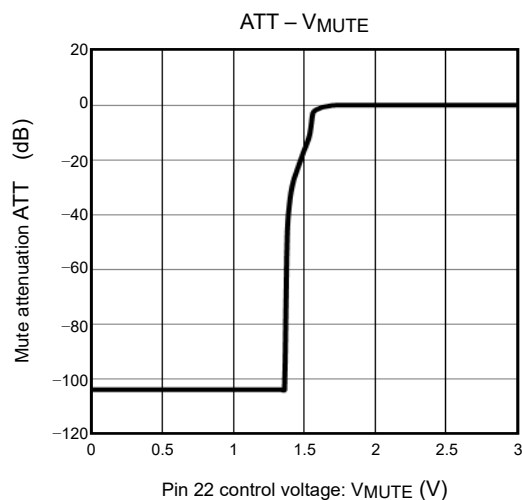

Figure 4 Mute Attenuation - VMUTE (V)

## 9. Mute Mode

The mute modes in this product are a mute at standby off and an internal mute for low voltage.

### 9.1 Low Voltage Mute

When the supply voltage became lower than 5.5(typ.), it operates the mute circuit automatically. This function prevents the large audible transient noise which is generated by low  $V_{DD}$

### 9.2 Standby off Mute

A mute operation starts automatically inside the IC after standby-off until the Ripple pin voltage becomes about  $1/4V_{DD}(V)$ .

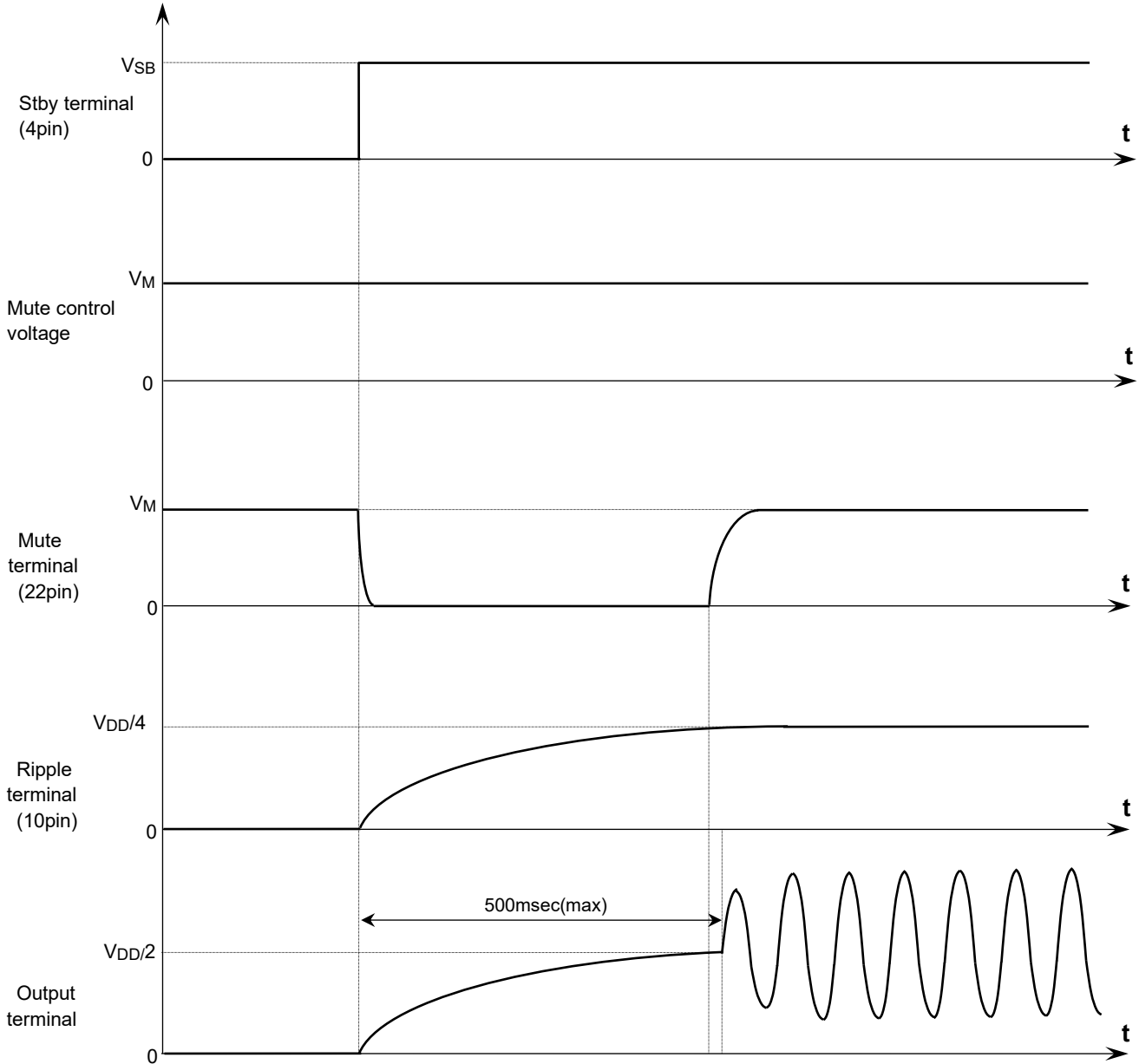

Figure5 The timing chart when standby-off

### 9.3 Mute off after standby off

It affects pop noise generated when capacitor of ripple, input and ACGND is finished to charge; thus, it must be determined on a per-application basis.

Please set "Mute-off" that it is sufficient margin in considering a enough charge time after the middle point potential stable.

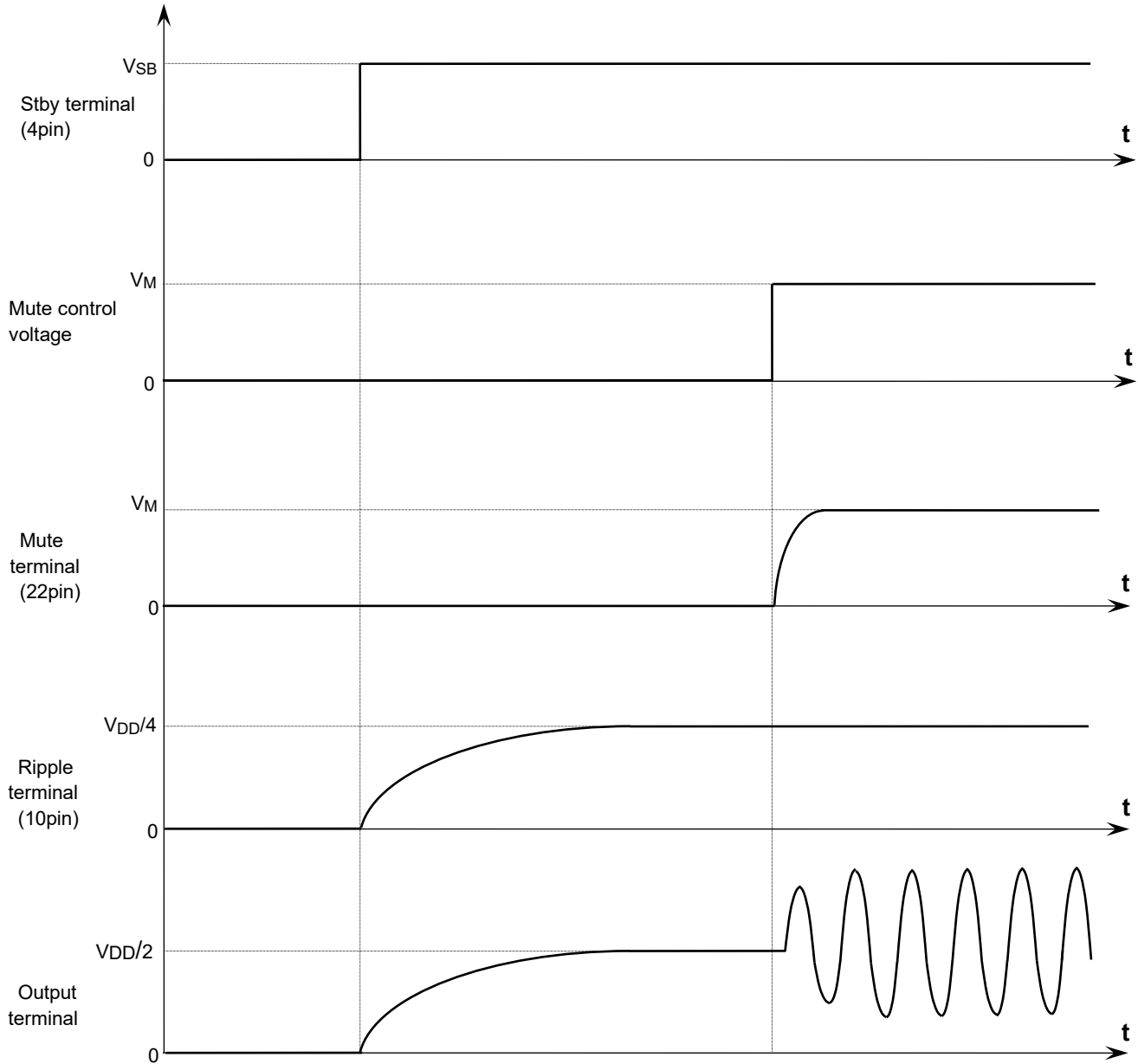

Figure6 The timing chart when standby-off

## 10. 25pin: Output DC Offset Detection

This function detects the offset voltage between OUT(+) and OUT(-). The detection result is gotten by pin25. When the offset voltage appeared by the external parts accident, for example the leak of coupling capacitor, this function can contribute to a part of safety system to prevent the speaker damage. In case of being unused this function, use this IC as open-connection on pin25.

### 10.1 Output DC offset detection

This function detects the offset voltage between OUT(+) and OUT(-). The detection result is gotten by pin25. When the offset voltage appeared by the external parts accident, for example the leak of coupling capacitor, this function can contribute to a part of safety system to prevent the speaker damage.

The example flow chart: The safety system to prevent damaging to speakers by abnormal offset.

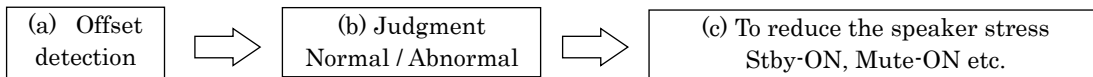

The result of detection does not judge the abnormal offset or not. This function detects only the offset voltage which is decided by specification.

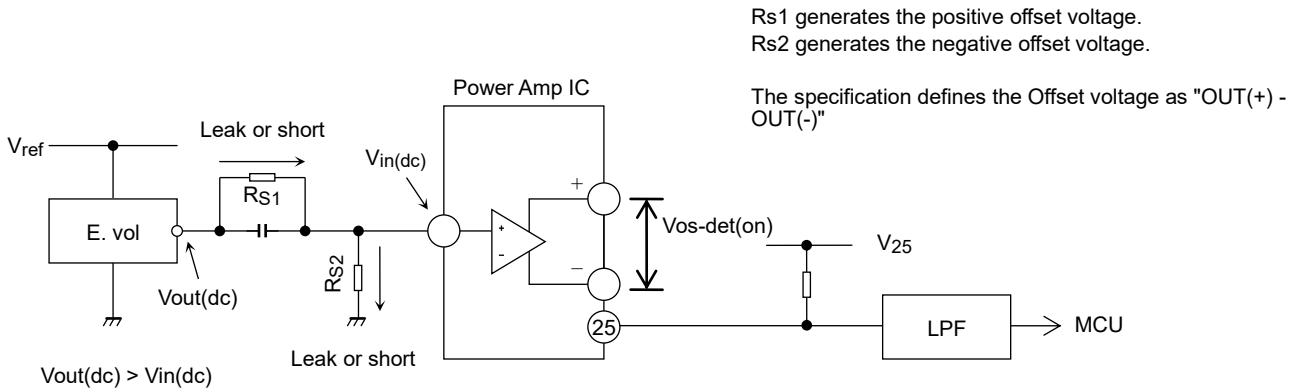

**Figure 7 Abnormal output offset voltage**

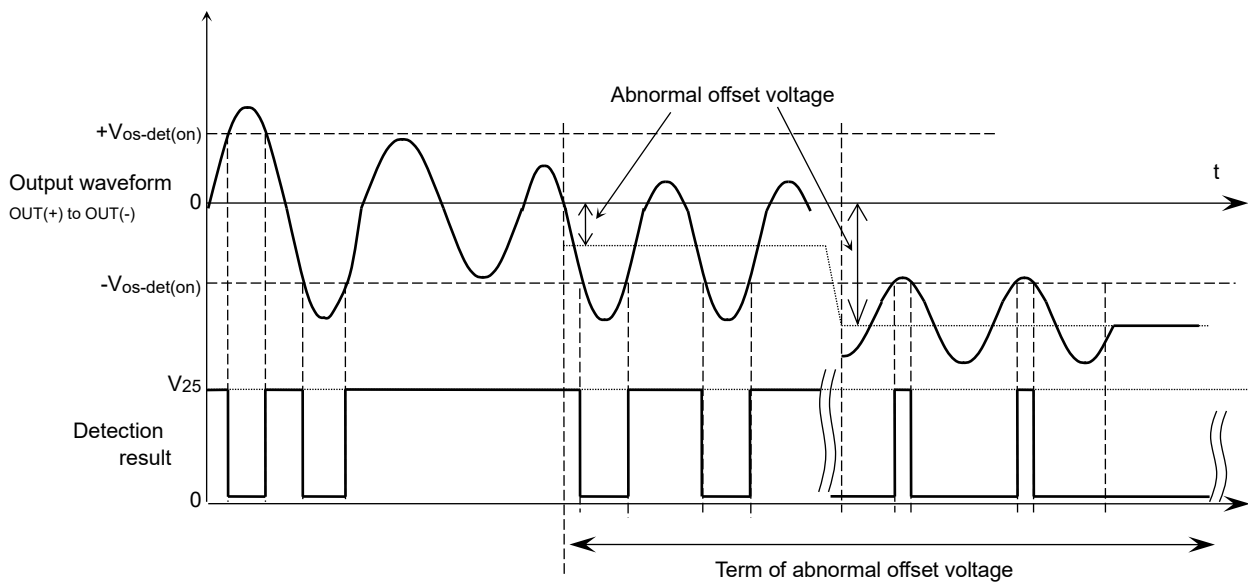

**Figure 8 The detected result and audio output waveform**

## 10.2 Output to GND short detection

In case of shorting output to V<sub>DD</sub>/GND or over power supplied is turned on the MOS transistor and can be detected.(Reference: Figure9) Threshold of over voltage protection: V<sub>DD</sub>=23V(typ.). And in the case of output to output is turned on the MOS transistor and can be detected.(Reference: Figure10) Please use under I<sub>o</sub>=500μA at the time of a pull-up.

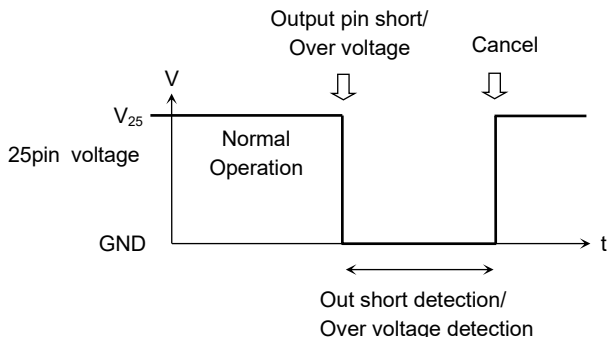
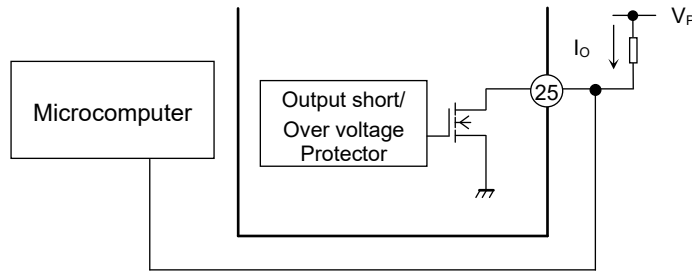

**Figure 9 Output short detection/ Overvoltage detection**

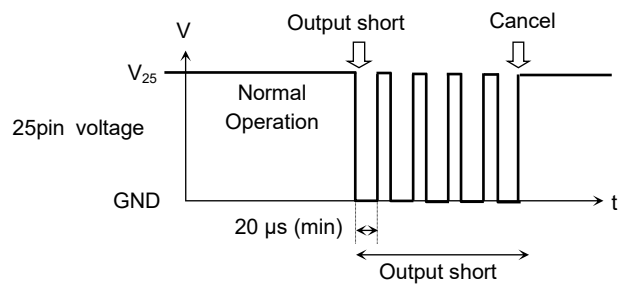

**Figure10 Output short detection**

## 11. Engine idle reduction capability

This IC can continually provide audio output when the battery voltage reboot from it rapidly drop(idling stop mode).This function This can reduce the sound cutting and pop sound since it switch to 1/4V<sub>DD</sub> for middle voltage.

## 12. Protection Functions

This product has internal protection circuits such as thermal shut down, over voltage, out to VDD, out to GND, and out to out short circuit protections.

(1) Thermal shut down

It operates when junction temperature exceeds 150°C (typ.).  
When it operates, it is protected in the following order.

1. An Attenuation of an output starts first and the amount of attenuation also increases according to a temperature rising,
2. All outputs become in a mute state, when temperature continues rising in spite of output attenuation.
3. Shutdown function starts, when a temperature rise continues through all outputs are in a mute state.

In any case if temperature falls, it will return automatically.

(2) Over voltage

It operates when voltage exceeding operating range is supplied to VDD pin. If voltage falls, it will return automatically. When it operates, output bias is turned off and an output is intercepted.

(3) Short to VDD, Short to GND, Output to output short

It operates when each pin is in irregular connection. If irregular connection is canceled, it will return automatically.

Short circuit protection can operate for each channel.

When it operates, output bias of corresponding output is turned off and an output is intercepted.

Example) If channel 1 output shorts, channel 1 is protected but other channels 2 to 4 are available.

(4) Prevention of speaker damage (in case of a layer short-circuit of the speaker)

When the DC resistance between the OUT+ and OUT- pins falls below 1 Ω, the output current exceeds 4 A. At this time, the protection circuit is activated to limit the current draw into the speaker.

This feature prevents the speaker from being damaged, as follows:

< Speaker damaging scenario >

A DC current of over 4 V is applied to the speaker due to an external circuit failure (Note 1).

(Abnormal DC output offset)



The speaker impedance becomes 1 Ω or less due to a layer short.



A current of over 4 A flows into the speaker, damaging the speaker.

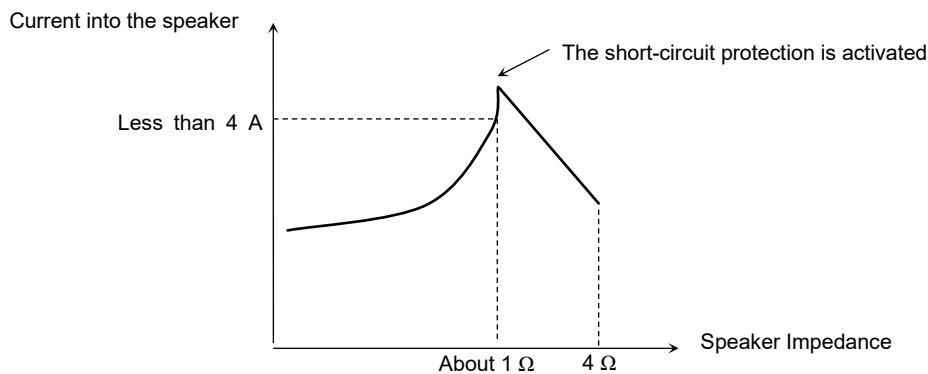

**Figure 11 Prevention of speaker damage**

Note1: An abnormal DC offset voltage is incurred when the input bias to the power IC is lost due to a leakage current from a coupling capacitor at the input or a short-circuit between the IN and adjacent lines.

## 13. Absolute Maximum Ratings

(Ta = 25°C unless otherwise specified)

Characteristics	Condition	Symbol	Rating	Unit
Supply voltage (surge)	max0.2s	V <sub>DD</sub> (surge)	50	V
Supply voltage (DC)		V <sub>DD</sub> (DC)	30	V
Supply voltage (operation)		V <sub>DD</sub> (opr)	18	V
Output current (peak)		I <sub>O</sub> (peak)	9	A
Power dissipation	(Note)	P <sub>D</sub>	125	W
Operating temperature range		T <sub>opr</sub>	-40 to 105	°C
Storage temperature		T <sub>stg</sub>	-55 to 150	°C
GND potential tolerance		GNDmax	-0.3 to 0.3	V
Vin max voltage		Vinmax	-0.3 to 5.3	V
Max Standby/Mute input voltage		VSTBmax	-0.3 to V <sub>DD</sub> +0.3	V
AC-GND/ripple max input voltage		VACGmax	-0.3 to 5.3	V

Note: Package thermal resistance R<sub>th(j-t)</sub> = 1°C/W (typ.) (Ta = 25°C, with infinite heat sink)

The absolute maximum ratings of a semiconductor device are a set of specified parameter values, which must not be exceeded during operation, even for an instant.

If any of these rating would be exceeded during operation, the device electrical characteristics may be irreparably altered and the reliability and lifetime of the device can no longer be guaranteed. Moreover, these operations with exceeded ratings may cause break down, damage, and/or degradation to any other equipment. Applications using the device should be designed such that each maximum rating will never be exceeded in any operating conditions.

Before using, creating, and/or producing designs, refer to and comply with the precautions and conditions set forth in this document.

### 13.1 Power Dissipation

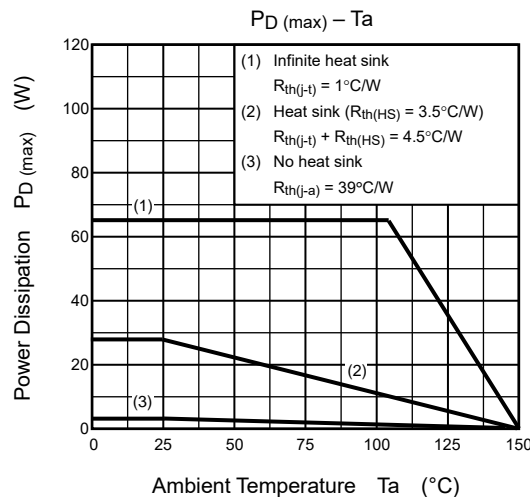

## 14. Operating Ranges

Characteristics	Symbol	Condition	Min	Typ.	Max	Unit
Supply voltage	V <sub>DD</sub>	R <sub>L</sub> =4Ω	6	—	18	V

## 15. Electrical Characteristics

( $V_{DD} = 13.2\text{ V}$ ,  $f = 1\text{ kHz}$ ,  $R_L = 4\ \Omega$ ,  $G_V = 26\text{ dB}$ ,  $T_a = 25^\circ\text{C}$  unless otherwise specified)

Characteristics	Symbol	Test Condition	Min	Typ.	Max	Unit
Quiescent supply current	$I_{CCQ}$	$V_{IN} = 0\text{ V}$	—	200	300	mA
Output power	$P_{OUT\ MAX\ (1)}$	$V_{DD} = 15.2\text{ V}$ , max POWER	—	45	—	W
	$P_{OUT\ MAX\ (2)}$	$V_{DD} = 14.4\text{ V}$ , max POWER	—	40	—	
	$P_{OUT\ (1)}$	$V_{DD} = 14.4\text{ V}$ , THD = 10%	—	26	—	
	$P_{OUT\ (2)}$	THD = 10%	—	22	—	
Total harmonic distortion	THD	$P_{OUT} = 4\text{ W}$	—	0.01	0.07	%
Voltage gain	$G_V$	$V_{OUT} = 0.775\text{ Vrms}$	25	26	27	dB
Channel-to-channel voltage gain	$\Delta G_V$	$V_{OUT} = 0.775\text{ Vrms}$	-1.0	0	1.0	dB
Output noise voltage	$V_{NO}$	$R_g = 0\ \Omega$ , BW = 20 Hz to 20 kHz	—	45	70	$\mu\text{Vrms}$
Ripple rejection ratio	R.R.	$f_{rip} = 100\text{ Hz}$ , $R_g = 620\ \Omega$ $V_{rip} = 0.775\text{ Vrms}$ (Note1)	50	70	—	dB
Crosstalk	C.T.	$R_g = 620\ \Omega$ $P_{OUT} = 4\text{ W}$	—	80	—	dB
Output offset voltage	$V_{OFFSET}$	—	-90	0	90	mV
Input resistance	$R_{IN}$	—	—	90	—	k $\Omega$
Standby current	$I_{STBY}$	Standby condition	—	0.01	1	$\mu\text{A}$
Standby control voltage	$V_{SB\ H}$ (Note)	POWER: ON	2.2	—	$V_{DD}$	V
	$V_{SB\ L}$	POWER: OFF	0	—	0.8	
Mute control voltage	$V_M\ H$ (Note)	Mute: OFF	2.2	—	$V_{DD}$	V
	$V_M\ L$	Mute: ON, $R_1 = 47\text{ k}\Omega$	0	—	0.8	
Mute attenuation	ATT M	Mute: ON, $DIN\_AUDIO$ $V_{OUT} = 7.75\text{ Vrms} \rightarrow$ Mute: OFF	85	100	—	dB
DC offset threshold voltage	$V_{off-set}$	$I_o = 500\ \mu\text{A}$ , Out(+)-Out(-)	$\pm 1.0$	$\pm 1.5$	$\pm 2.0$	V
Pin 25 saturation voltage (at each detector ON condition)	P25-Det(Note)	$I_o = 500\ \mu\text{A}$ , (pin 25 = low)	—	100	500	mV

Note:  $V_{SBH}, V_{MH}, P25\text{-Sat} : 18\text{V(max)}$

Note1:  $f_{rip}$ : Ripple frequency

$V_{rip}$ : Ripple signal voltage (AC fluctuations in the power supply)

## 16. Test Circuit

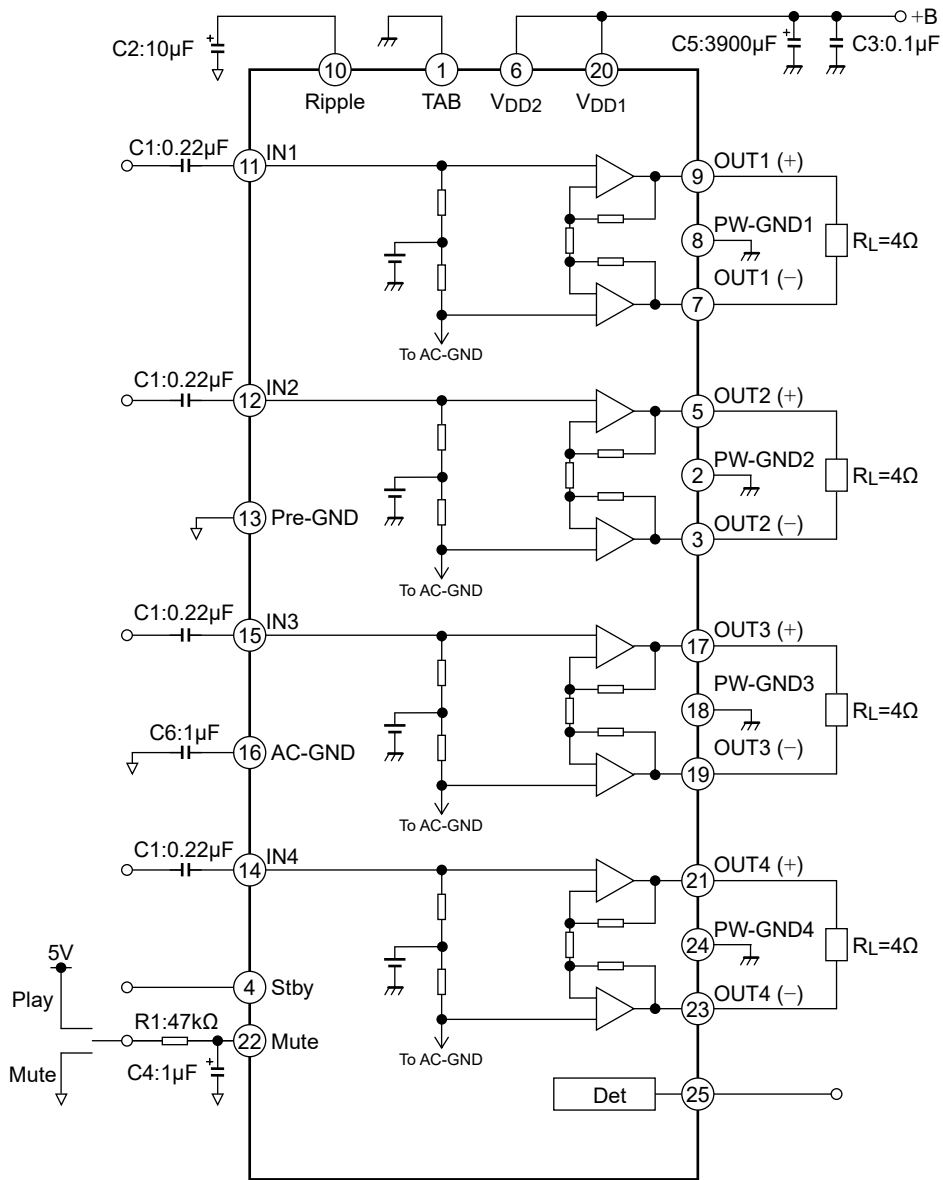

Components in the test circuits are only used to obtain and confirm the device characteristics.

## 17. Characteristic Chart

### 17.1 Total Harmonic Distortion vs. Output Power

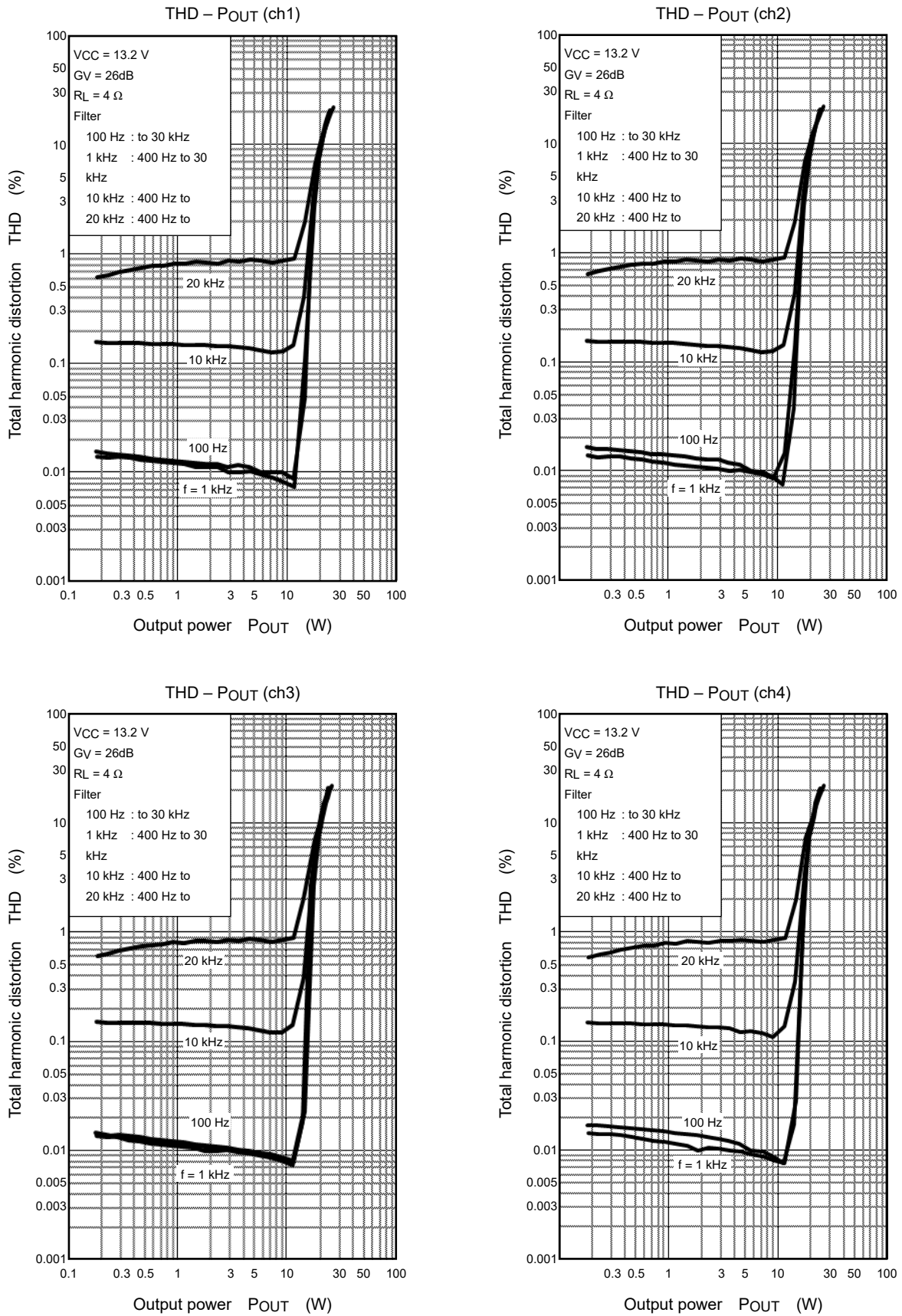
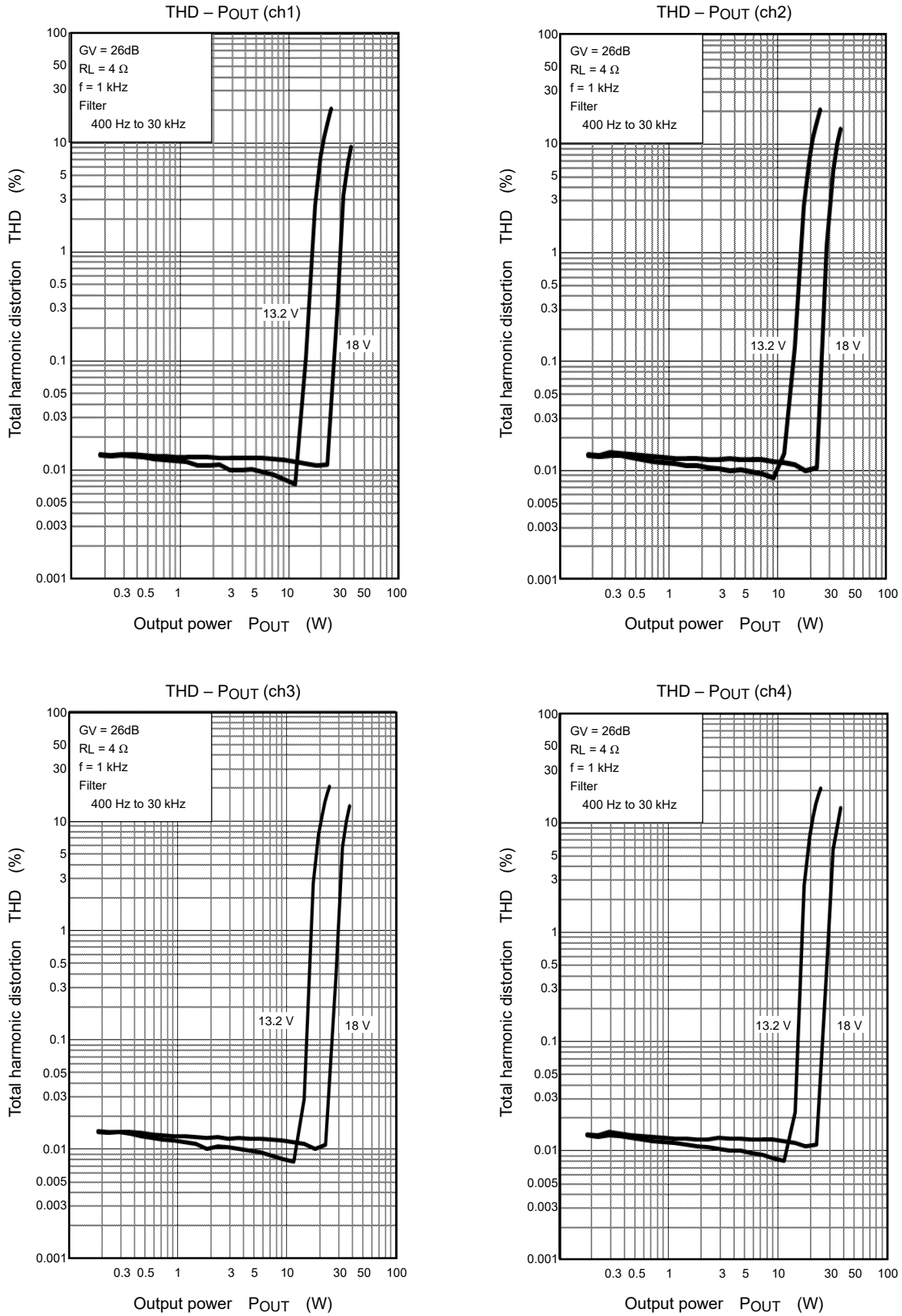

Figure 17-1 Total Harmonic Distortion of Each Frequency (RL = 4 Ω)



**Figure 17-2 Total Harmonic Distortion by Power-supply Voltage (RL = 4 Ω)**

17.2 Various Frequency Characteristics

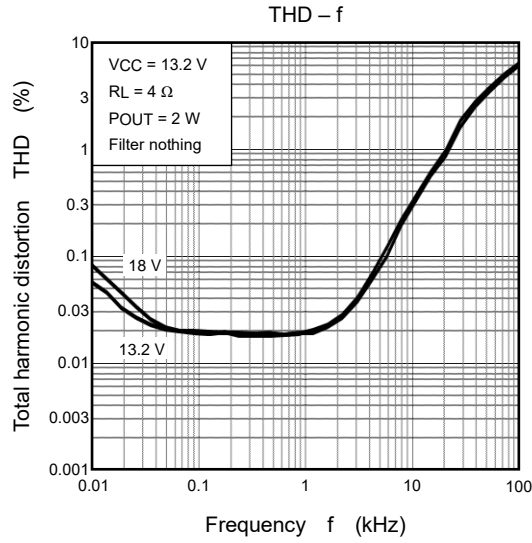

Figure 17-3 Frequency Characteristics of Total Harmonic Distortion

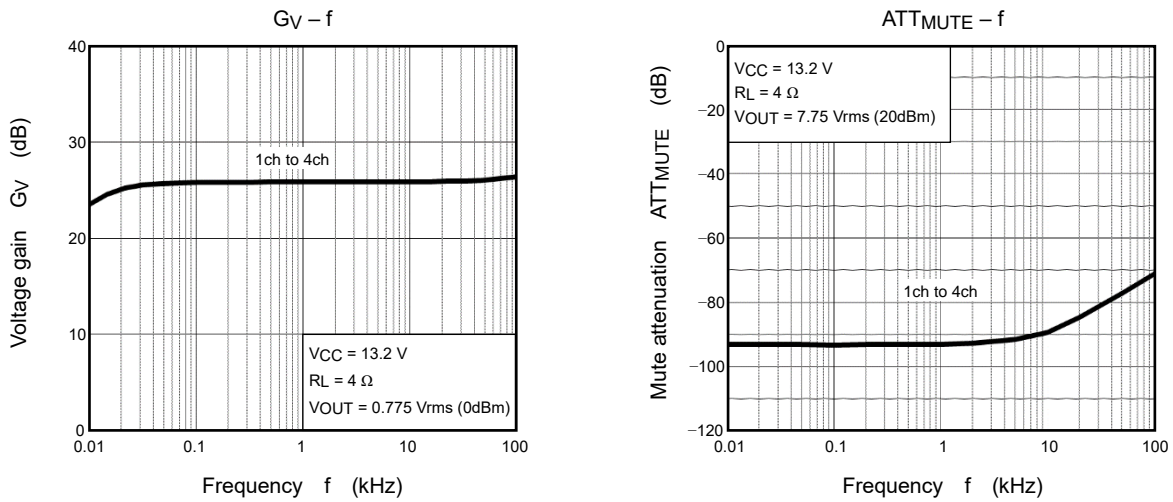

Figure 17-4 Frequency Characteristics of Voltage Gain and Mute Attenuation

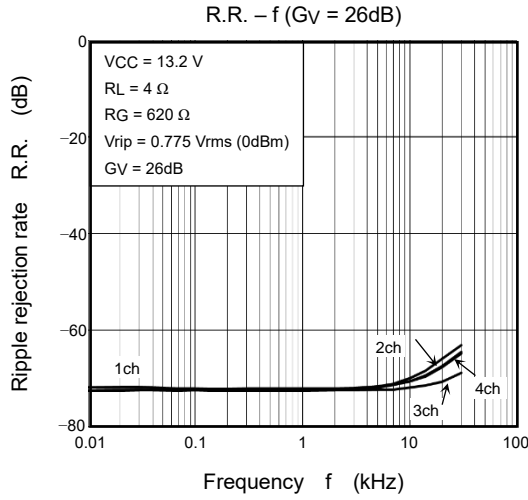

Figure 17-5 Frequency Characteristics of Ripple Rejection Rate

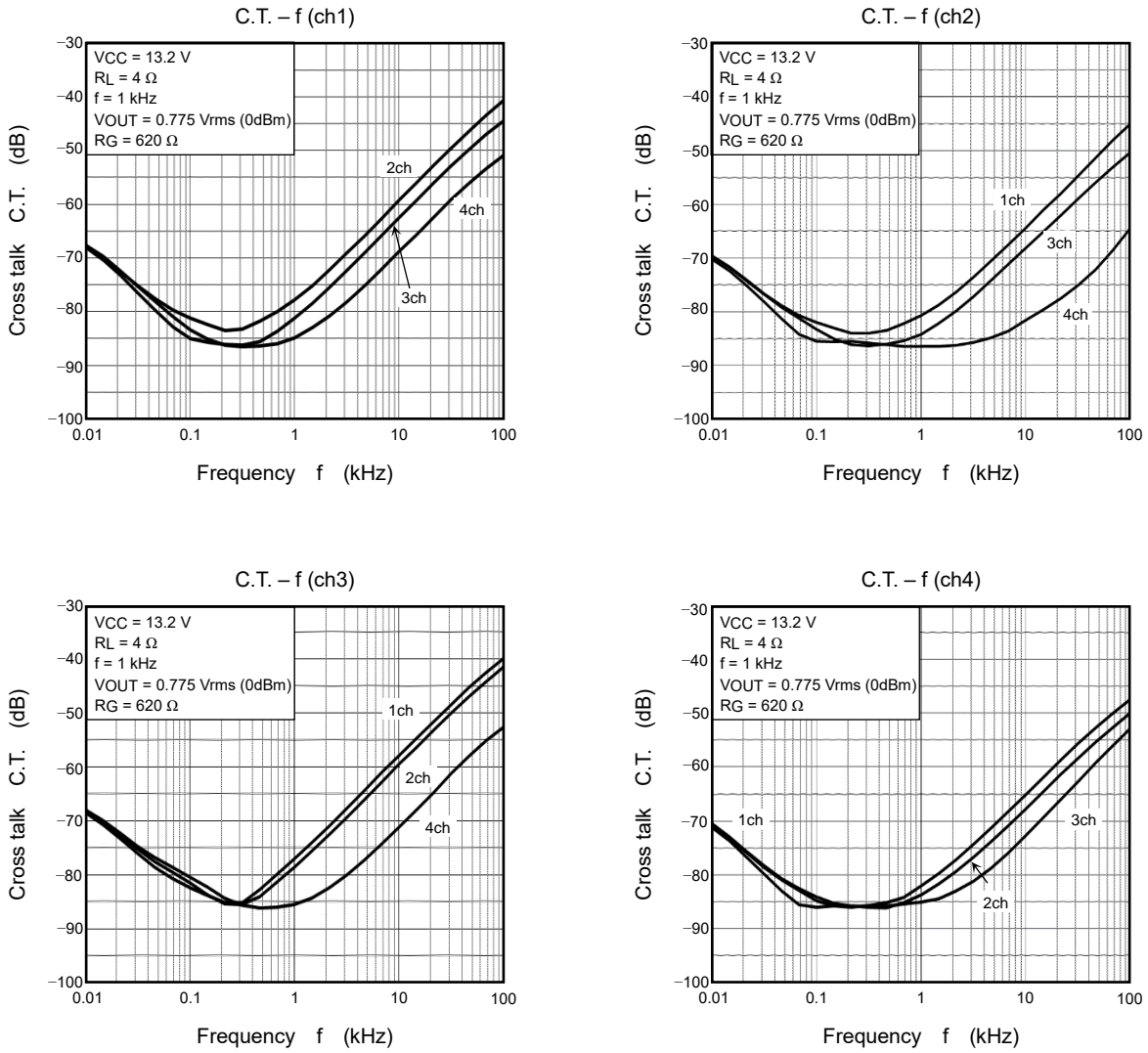
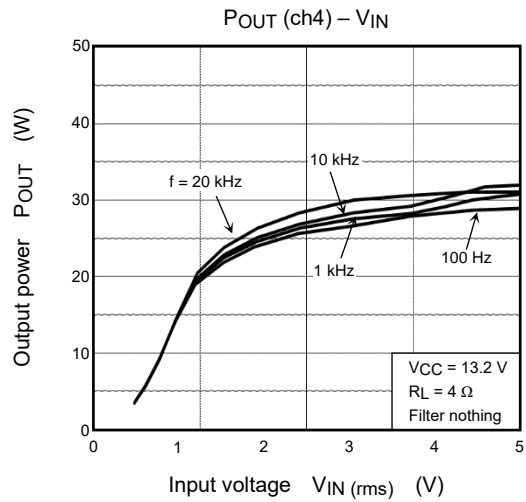
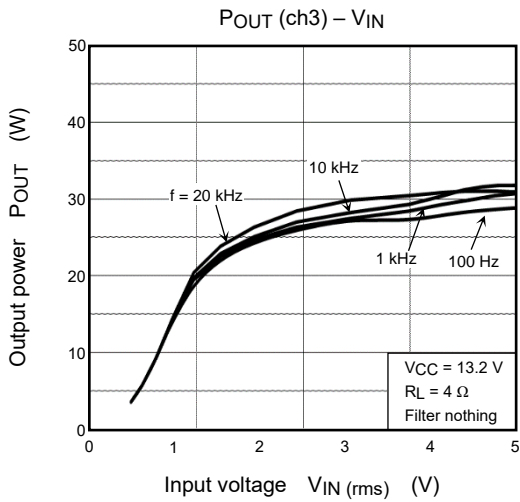
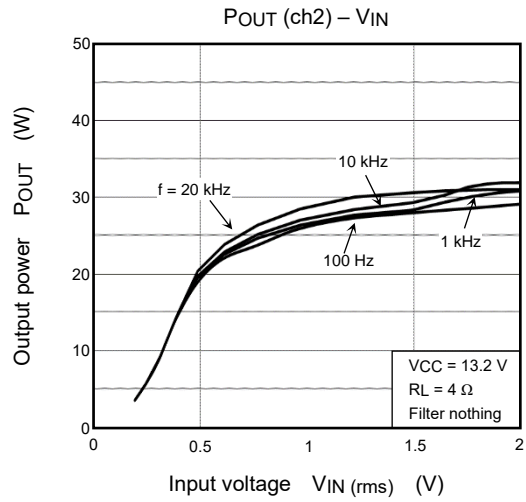
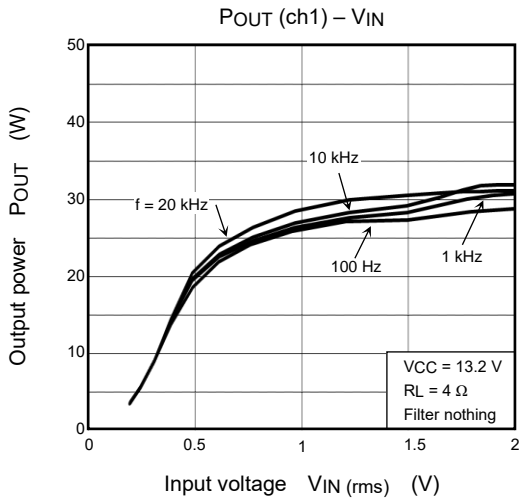
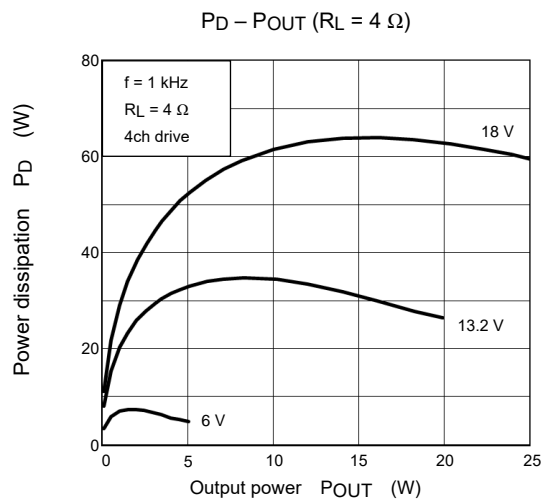

Figure 17-6 Frequency Characteristics of Cross Talk

## 17.3 Output Power Characteristics to Input Voltage



## 17.4 Power Dissipation vs. Output Power



## 17.5 Other Characteristic

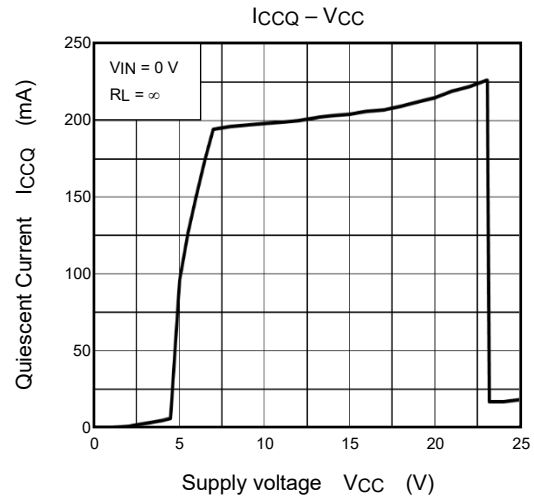
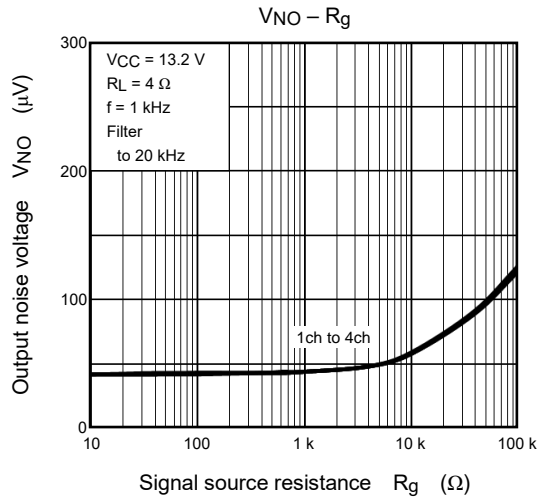

## 18. Package Dimensions

HZIP25-P-1.00F

Unit: mm

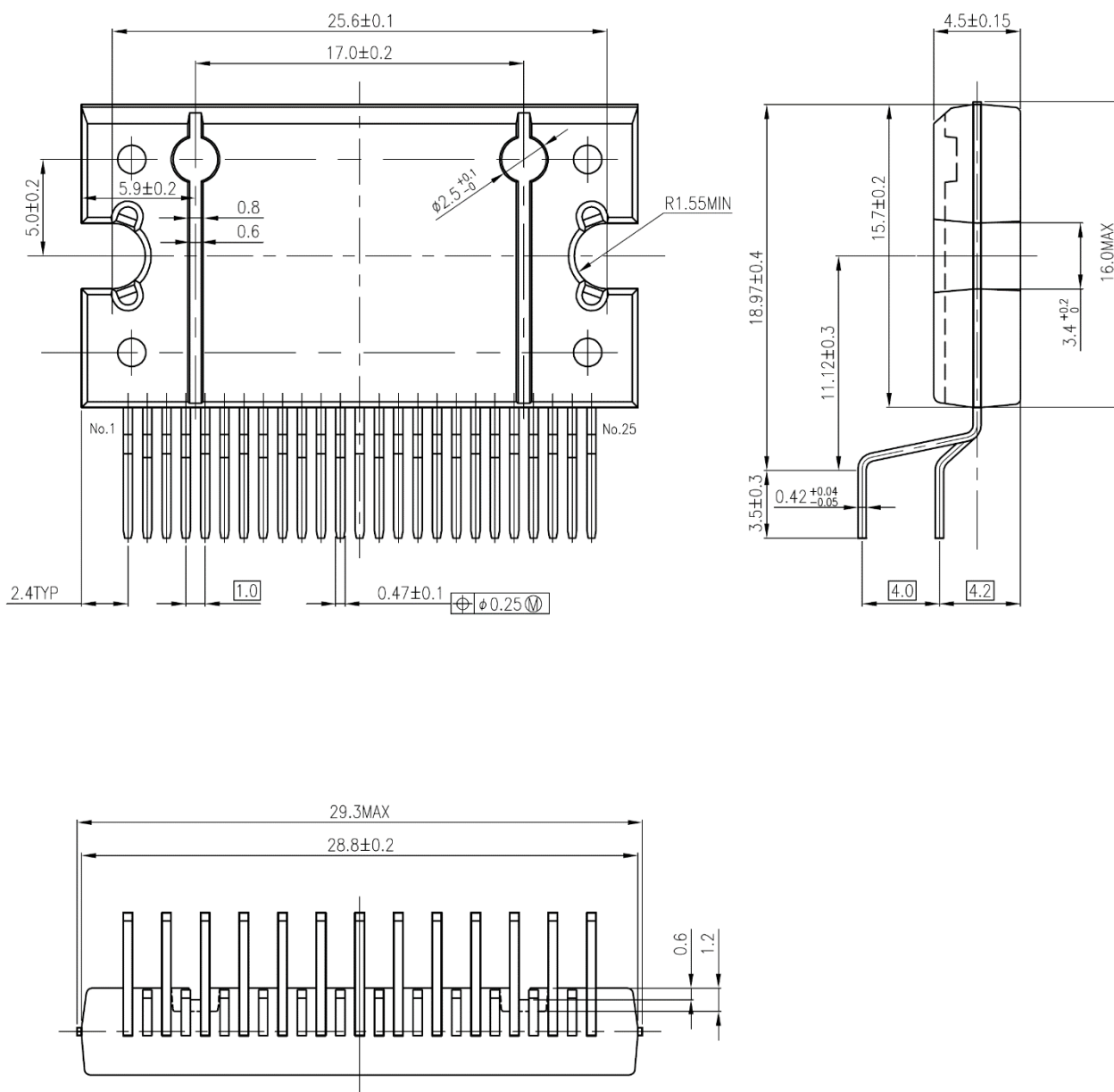

Weight: 7.7 g (typ.)

## 19. 4ch Power IC Evaluation Board

This drawing is a component side, and a schematic diagram of evaluation board “RP-2024 for 4ch power IC using HZIP25-P-1.00F (SPP25), a solder side.

Note: This board can be shared with some products.

Please confirm external parts of the evaluated product beforehand when you unite the evaluation board.

- Component side

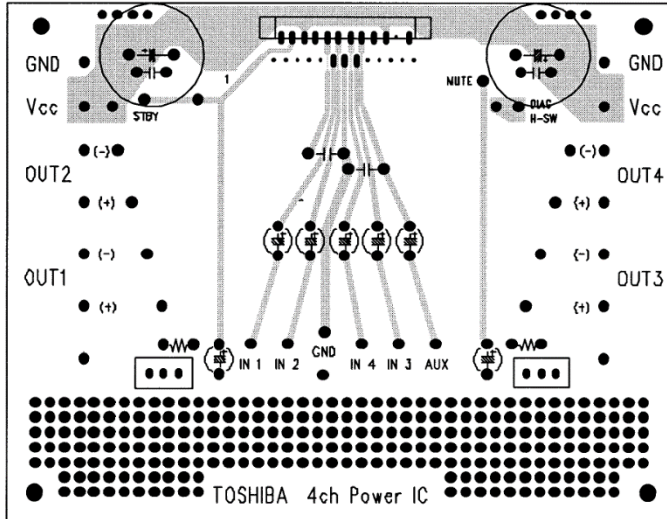

Figure 19-1 Pattern of Evaluation Board (component side)

- Solder side

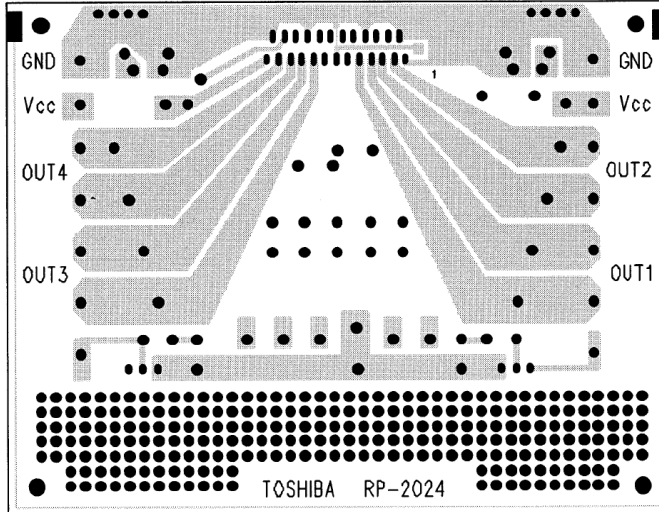

Figure 19-2 Pattern of Evaluation Board (solder side)

## 20. Attention in Use

- Use an appropriate power supply fuse to ensure that a large current does not continuously flow in case of over current and/or IC failure. The IC will fully break down when used under conditions that exceed its absolute maximum ratings, when the wiring is routed improperly or when an abnormal pulse noise occurs from the wiring or load, causing a large current to continuously flow and the breakdown can lead smoke or ignition. To minimize the effects of the flow of a large current in case of breakdown, appropriate settings, such as fuse capacity, fusing time and insertion circuit location, are required.
- If your design includes an inductive load such as a motor coil, incorporate a protection circuit into the design to prevent device malfunction or breakdown caused by the current resulting from the inrush current at power ON or the negative current resulting from the back electromotive force at power OFF. For details on how to connect a protection circuit such as a current limiting resistor or back electromotive force adsorption diode, refer to individual IC datasheets or the IC databook. IC breakdown may cause injury, smoke or ignition.
- Use a stable power supply with ICs with built-in protection functions. If the power supply is unstable, the protection function may not operate, causing IC breakdown. IC breakdown may cause injury, smoke or ignition.
- Carefully select external components (such as inputs and negative feedback capacitors) and load components (such as speakers), for example, power amp and regulator. If there is a large amount of leakage current such as input or negative feedback condenser, the IC output DC voltage will increase. If this output voltage is connected to a speaker with low input withstand voltage, overcurrent or IC failure can cause smoke or ignition. (The over current can cause smoke or ignition from the IC itself.) In particular, please pay attention when using a Bridge Tied Load (BTL) connection type IC that inputs output DC voltage to a speaker directly.
- **Over current Protection Circuit**  
Over current protection circuits (referred to as current limiter circuits) do not necessarily protect ICs under all circumstances. If the Over current protection circuits operate against the over current, clear the over current status immediately. Depending on the method of use and usage conditions, such as exceeding absolute maximum ratings can cause the over current protection circuit to not operate properly or IC breakdown before operation. In addition, depending on the method of use and usage conditions, if over current continues to flow for a long time after operation, the IC may generate heat resulting in breakdown.
- **Thermal Shutdown Circuit**  
Thermal shutdown circuits do not necessarily protect ICs under all circumstances. If the Thermal shutdown circuits operate against the over temperature, clear the heat generation status immediately. Depending on the method of use and usage conditions, such as exceeding absolute maximum ratings can cause the thermal shutdown circuit to not operate properly or IC breakdown before operation.
- **Heat Radiation Design**  
When using an IC with large current flow such as power amp, regulator or driver, please design the device so that heat is appropriately radiated, not to exceed the specified junction temperature ( $T_j$ ) at any time and condition. These ICs generate heat even during normal use. An inadequate IC heat radiation design can lead to decrease in IC life, deterioration of IC characteristics or IC breakdown. In addition, please design the device taking into considerate the effect of IC heat radiation with peripheral components.
- **Installation to Heat Sink**  
Please install the power IC to the heat sink not to apply excessive mechanical stress to the IC. Excessive mechanical stress can lead to package cracks, resulting in a reduction in reliability or breakdown of internal IC chip. In addition, depending on the IC, the use of silicon rubber may be prohibited. Check whether the use of silicon rubber is prohibited for the IC you intend to use, or not. For details of power IC heat radiation design and heat sink installation, refer to individual technical datasheets or IC databooks.

## RESTRICTIONS ON PRODUCT USE

- Toshiba Corporation, and its subsidiaries and affiliates (collectively "TOSHIBA"), reserve the right to make changes to the information in this document, and related hardware, software and systems (collectively "Product") without notice.
- This document and any information herein may not be reproduced without prior written permission from TOSHIBA. Even with TOSHIBA's written permission, reproduction is permissible only if reproduction is without alteration/omission.
- Though TOSHIBA works continually to improve Product's quality and reliability, Product can malfunction or fail. Customers are responsible for complying with safety standards and for providing adequate designs and safeguards for their hardware, software and systems which minimize risk and avoid situations in which a malfunction or failure of Product could cause loss of human life, bodily injury or damage to property, including data loss or corruption. Before customers use the Product, create designs including the Product, or incorporate the Product into their own applications, customers must also refer to and comply with (a) the latest versions of all relevant TOSHIBA information, including without limitation, this document, the specifications, the data sheets and application notes for Product and the precautions and conditions set forth in the "TOSHIBA Semiconductor Reliability Handbook" and (b) the instructions for the application with which the Product will be used with or for. Customers are solely responsible for all aspects of their own product design or applications, including but not limited to (a) determining the appropriateness of the use of this Product in such design or applications; (b) evaluating and determining the applicability of any information contained in this document, or in charts, diagrams, programs, algorithms, sample application circuits, or any other referenced documents; and (c) validating all operating parameters for such designs and applications. **TOSHIBA ASSUMES NO LIABILITY FOR CUSTOMERS' PRODUCT DESIGN OR APPLICATIONS.**
- **PRODUCT IS NEITHER INTENDED NOR WARRANTED FOR USE IN EQUIPMENTS OR SYSTEMS THAT REQUIRE EXTRAORDINARILY HIGH LEVELS OF QUALITY AND/OR RELIABILITY, AND/OR A MALFUNCTION OR FAILURE OF WHICH MAY CAUSE LOSS OF HUMAN LIFE, BODILY INJURY, SERIOUS PROPERTY DAMAGE AND/OR SERIOUS PUBLIC IMPACT ("UNINTENDED USE").** Except for specific applications as expressly stated in this document, Unintended Use includes, without limitation, equipment used in nuclear facilities, equipment used in the aerospace industry, Class 3 medical devices, equipment used for automobiles, and military vehicles and munitions. **IF YOU USE PRODUCT FOR UNINTENDED USE, TOSHIBA ASSUMES NO LIABILITY FOR PRODUCT.** For details, please contact your TOSHIBA sales representative or contact us via our website.
- Do not disassemble, analyze, reverse-engineer, alter, modify, translate or copy Product, whether in whole or in part.
- Product shall not be used for or incorporated into any products or systems whose manufacture, use, or sale is prohibited under any applicable laws or regulations.
- The information contained herein is presented only as guidance for Product use. No responsibility is assumed by TOSHIBA for any infringement of patents or any other intellectual property rights of third parties that may result from the use of Product. No license to any intellectual property right is granted by this document, whether express or implied, by estoppel or otherwise.
- **ABSENT A WRITTEN SIGNED AGREEMENT, EXCEPT AS PROVIDED IN THE RELEVANT TERMS AND CONDITIONS OF SALE FOR PRODUCT, AND TO THE MAXIMUM EXTENT ALLOWABLE BY LAW, TOSHIBA (1) ASSUMES NO LIABILITY WHATSOEVER, INCLUDING WITHOUT LIMITATION, INDIRECT, CONSEQUENTIAL, SPECIAL, OR INCIDENTAL DAMAGES OR LOSS, INCLUDING WITHOUT LIMITATION, LOSS OF PROFITS, LOSS OF OPPORTUNITIES, BUSINESS INTERRUPTION AND LOSS OF DATA, AND (2) DISCLAIMS ANY AND ALL EXPRESS OR IMPLIED WARRANTIES AND CONDITIONS RELATED TO SALE, USE OF PRODUCT, OR INFORMATION, INCLUDING WARRANTIES OR CONDITIONS OF MERCHANTABILITY, FITNESS FOR A PARTICULAR PURPOSE, ACCURACY OF INFORMATION, OR NONINFRINGEMENT.**
- Do not use or otherwise make available Product or related software or technology for any military purposes, including without limitation, for the design, development, use, stockpiling or manufacturing of nuclear, chemical, or biological weapons or missile technology products (mass destruction weapons). Product and related software and technology may be controlled under the applicable export laws and regulations including, without limitation, the Japanese Foreign Exchange and Foreign Trade Law and the U.S. Export Administration Regulations. Export and re-export of Product or related software or technology are strictly prohibited except in compliance with all applicable export laws and regulations.
- Please contact your TOSHIBA sales representative for details as to environmental matters such as the RoHS compatibility of Product. Please use Product in compliance with all applicable laws and regulations that regulate the inclusion or use of controlled substances, including without limitation, the EU RoHS Directive. **TOSHIBA ASSUMES NO LIABILITY FOR DAMAGES OR LOSSES OCCURRING AS A RESULT OF NONCOMPLIANCE WITH APPLICABLE LAWS AND REGULATIONS.**