

## **TB67H400A**

### **Usage considerations**

#### **Summary**

The TB67H400A is brushed DC motor driver of a PWM chopper-type. The TB67H400A is a dual channel H-SW driver which can control two brushed DC motors. Moreover, the parallel control function (Large mode) of an output part is built in, and 1ch high current drive is also possible. Fabricated with the BiCD process, the TB67H400A is rated at 50V, 4.0A (2ch)/8.0A (1ch).

---

**Contents**

Summary.....	1
1. Power supply voltage .....	4
1.1. Power supply voltage and operating range.....	4
1.2. Power supply sequence .....	4
2. Output current .....	4
3. Control input.....	4
4. PWM control.....	5
5. Mixed Decay control .....	6
6. Switching characteristics .....	8
7. Function description .....	9
7.1. TBLKAB function .....	9
7.2. HBMODE function .....	9
7.3. Input/output function table .....	11
8. Example of application circuit .....	13
9. Power consumption of the IC.....	16
10. Power dissipation .....	17
11. Example of reference foot pattern .....	18
12. Board dimensions.....	19
12.1. Input.....	19
12.2. Main part.....	20
12.3. Options .....	21
Notes on Contents.....	22
IC Usage Considerations.....	22
RESTRICTIONS ON PRODUCT USE.....	24

---

## Figures

Figure 1.1	Power supply voltage and Operating range .....	4
Figure 4.1	OSCM oscillation frequency .....	5
Figure 5.1	Waveform in Mixed Decay Mode.....	6
Figure 5.2	Current waveform in Mixed Decay Mode (When a current value increases.).....	7
Figure 5.3	Current waveform in Mixed Decay Mode (When a current value decreases.) .....	7
Figure 6.1	Switching characteristics .....	8
Figure 7.1	2 DC motor (Small mode) operation.....	10
Figure 7.2	1 DC motor (Large mode) operation.....	10
Figure 8.1	Example of application circuit .....	13
Figure 10.1	Power dissipation.....	17
Figure 11.1	QFN48 foot pattern .....	18
Figure 11.2	HTSSOP48 foot pattern .....	18
Figure 12.1	Input .....	19
Figure 12.2	Main part.....	20
Figure 12.3	Options.....	21

## Tables

Table 6.1	Switching characteristics .....	8
Table 7.1	TBLKAB function .....	9
Table 7.2	HBMODE function .....	9
Table 7.3	Function of INA1 and INA2 (Small mode).....	11
Table 7.4	Function of INB1 and INB2 (Small mode).....	11
Table 7.5	Function of INA1 and INA2 (Large mode).....	12
Table 8.1	Recommended capacitor values for power supply terminal .....	14
Table 8.2	Recommended resistance values for current detection.....	14

## 1. Power supply voltage

### 1.1. Power supply voltage and operating range

In using the TB67H400A, the voltage should be applied to the terminals of VM, VREF.

The maximum rating of VM supply voltage is 50 V. Operating range of the power supply voltage is 10 to 47 V.

The maximum rating of VREF voltage is 5 V. Operating range of the voltage is 0 to 4.0 V.

As for the voltage of VREF, the voltage of the internal regulator of the IC (VCC) can be also used. (However, if the current is pulled out exceeding the capability of the internal regulator, the regulation of VCC may not be kept. When the voltage of VREF is applied by dividing the voltage of VCC, the total of the voltage-dividing resistance should not be less than 10 kΩ.

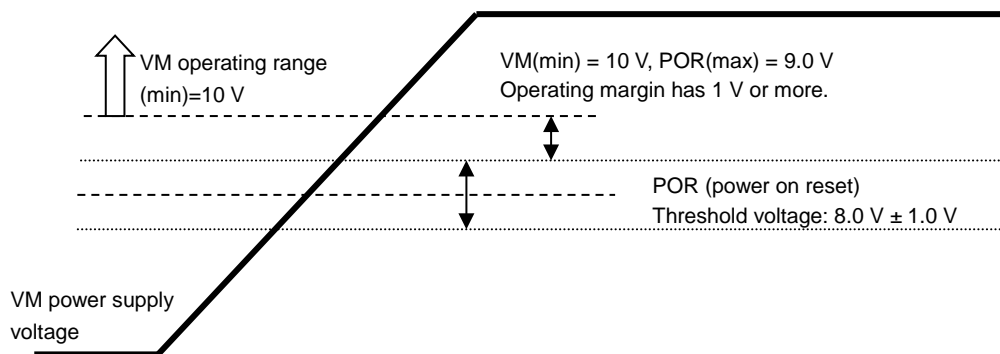

Figure 1.1 Power supply voltage and Operating range

### 1.2. Power supply sequence

There are no special procedures of inputting a power supply and shutdown because the TB67H400A incorporates the power on reset (POR). However, under the unstable state of inputting the power supply (VM) and shutdown, it is recommended to turn off the motor operation. Please operate the motor by switching the input signal after the power supply becomes in the stable state.

## 2. Output current

Motor usage current should be 3 A or less. The maximum current of the actual usage is limited depending on the usage conditions (the ambient temperature, the wiring pattern of the board, the radiation path, and the exciting design). Configure the most appropriate current value after calculating the heat and evaluating the board under the operating environment.

## 3. Control input

When the logic input signal is inputted under the condition that the voltage of VM is not supplied, the electromotive force by inputting signal is not generated. However, configure the input signal low level before the power supply is applied by referring to the description of the "1.2. Power supply sequence".

### 4. PWM control

The TB67H400A can adjust the internal oscillation frequency ( $f_{OSCM}$ ) and the chopping frequency ( $f_{chop}$ ) with the constant number of the external parts connecting to OSCM terminal. Generally, it is recommended to configure the frequency range from 50 kHz to 100 kHz on the basis of about 70 kHz.

- The relation equations of the OSCM oscillation frequency ( $f_{OSCM}$ ) and the chopping frequency ( $f_{chop}$ ) are as follows;

$$f_{OSCM} = 1 / [ 0.56 \times \{ C \times ( R1 + 500 ) \} ]$$

$$f_{chop} = f_{OSCM} / 16$$

- ※ C, R1: external constant number for OSCM ( $f_{OSCM}$  is about 1.12 MHz (typ.) at  $C = 270$  pF and  $R1 = 5.1$  k $\Omega$ .  $f_{chop}$  becomes considerable at about 70 kHz (typ.).)

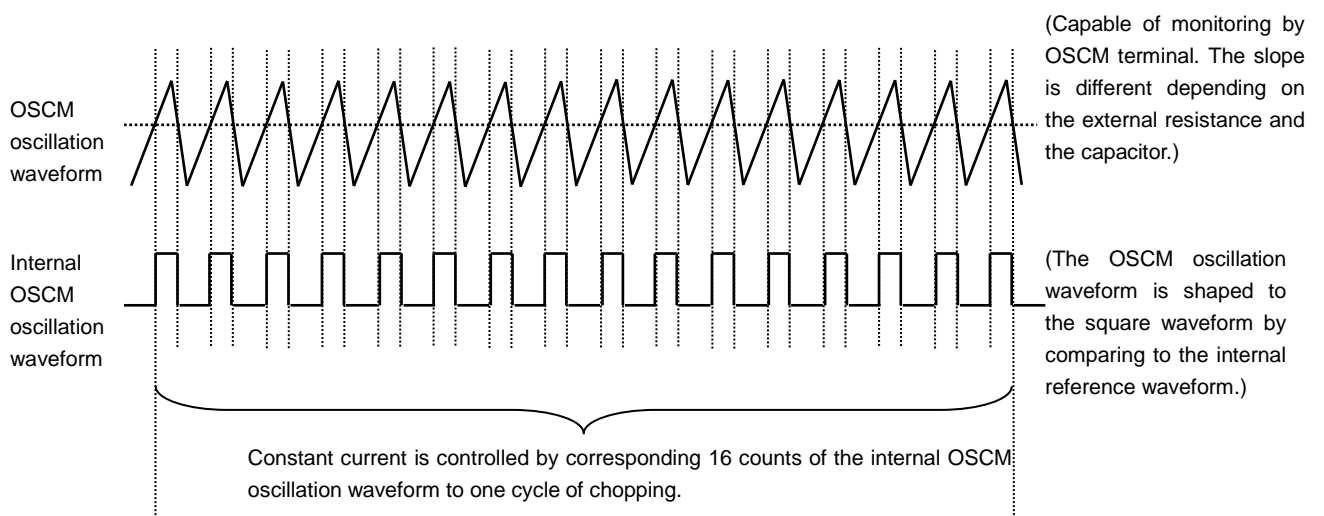

**Figure 4.1 OSCM oscillation frequency**

## 5. Mixed Decay control

The TB67H400A has the constant current control of Mixed Decay Mode. In the case of constant current control, the rate of Mixed Decay Mode which determines current Ripple is fixed to 37.5%.

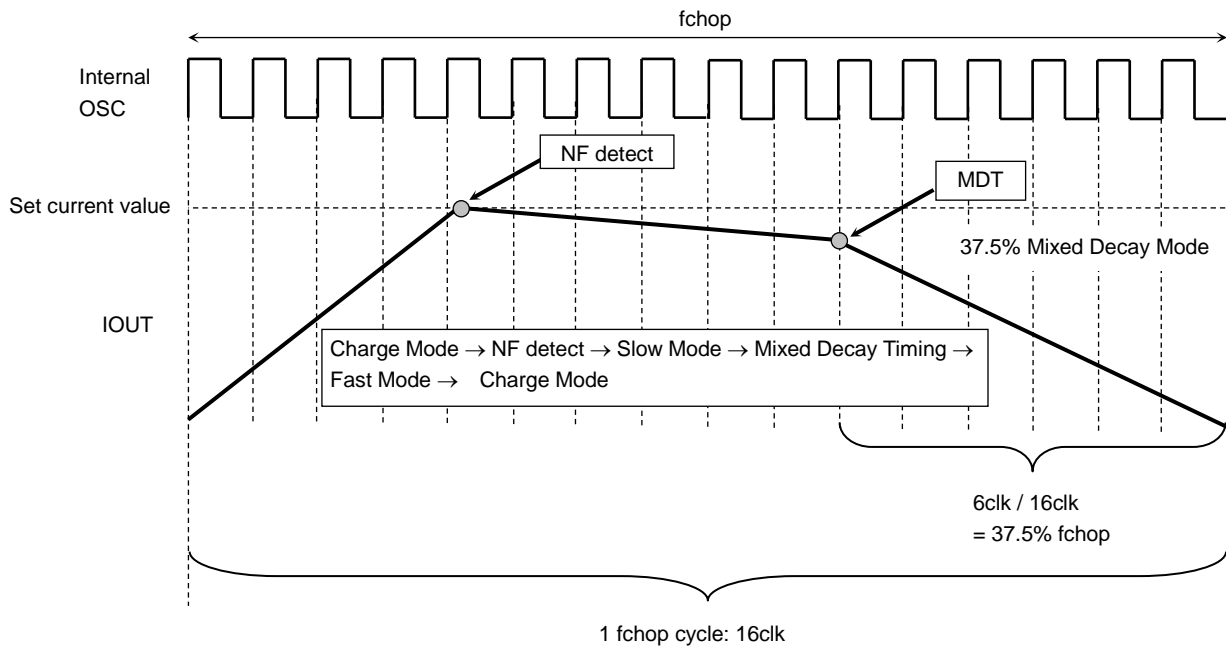

**Figure 5.1 Waveform in Mixed Decay Mode**

Timing charts may be simplified for explanatory purpose.

## Current waveform in Mixed Decay Mode

- When a current value increases (Mixed-Decay point is fixed to 37.5%)

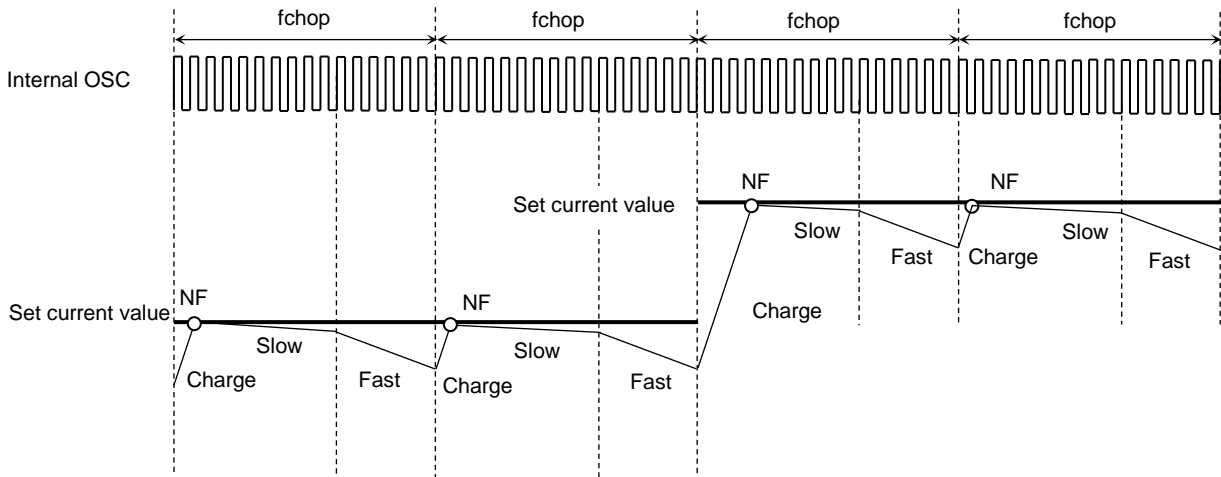

Figure 5.2 Current waveform in Mixed Decay Mode (When a current value increases.)

- When a current value decreases (Mixed-Decay point is fixed to 37.5%)

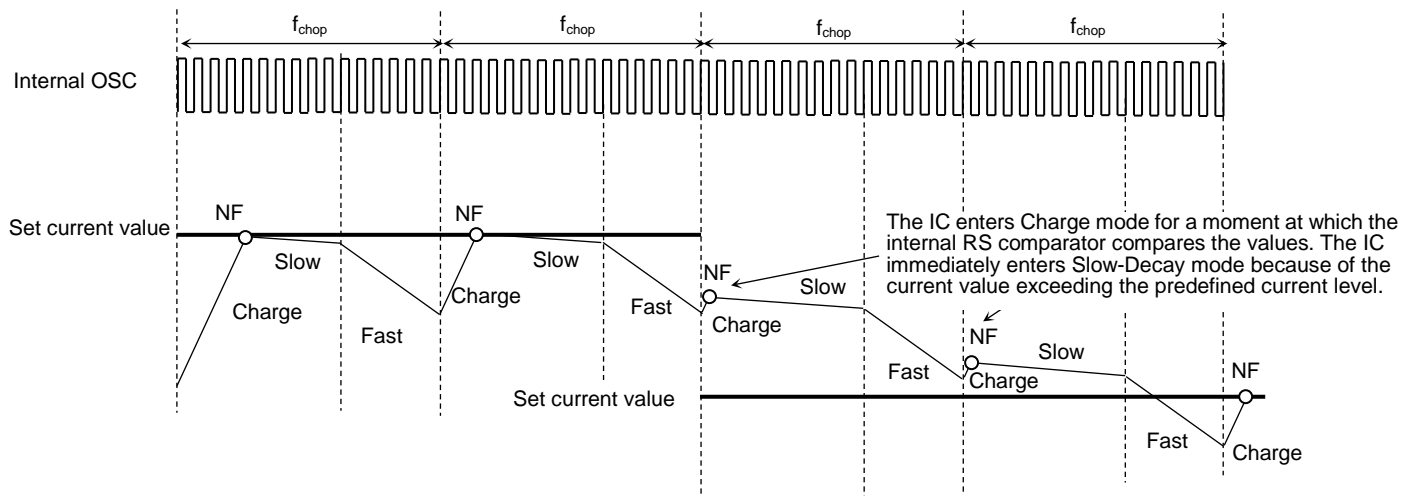

Figure 5.3 Current waveform in Mixed Decay Mode (When a current value decreases.)

The Charge period starts as the internal oscillator clock starts counting. When the output current reaches the predefined current level, the internal RS comparator detects the predefined current level (NF); as a result, the IC enters Slow-Decay mode.

The TB67H400A transits from Slow-Decay mode to Fast-Decay mode at the point 37.5% of a PWM frequency (one chopping frequency) remains in a whole PWM frequency period (on the rising edge of the 11th clock of the OSCM clock).

When the internal clocks of the OSCM terminal are counted 16 times, the Fast-Decay mode ends; and at the same time, the counter is reset, which brings the TB67H400A into Charge mode again.

Note: These figures are intended for illustrative purposes only. If designed more realistically, they would show transient response curves.

Timing charts may be simplified for explanatory purposes.

**6. Switching characteristics**

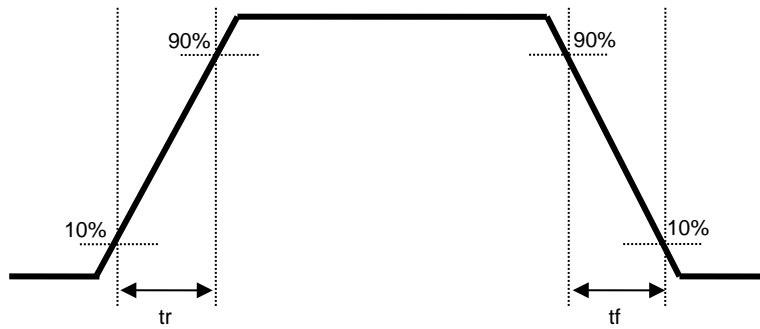

**Figure 6.1 Switching characteristics**

**Table 6.1 Switching characteristics**

$T_a = 25^\circ\text{C}$ ,  $V_M = 24\text{ V}$ , No load

Item	Typ.	Unit
$t_r$	80	ns
$t_f$	90	ns



## 7. Function description

### 7.1. TBLKAB function

This terminal sets the noise reduction time Digital tBLK.

\*The Digital tBLK is used to avoid error judgment of varistor recovery current that occurs in charge drive mode when H-bridges are used with DC motors. The Digital tBLK time can be controlled with TBLKAB pin.

By setting Digital tBLK, direct PWM control and constant-current control is possible, but the motor current will rise above the predefined current level (NF) while digital tBLK is active.

\*Besides Digital tBLK, Analog tBLK (400ns (typ.)) settled by an internal constant of IC is also attached.

**Table 7.1 TBLKAB function**

TBLKAB input	Function
L	Setting time width of Digital tBLK = fOSCM × 4clk
H	Setting time width of Digital tBLK = fOSCM × 6clk

### 7.2. HBMODE function

This terminal sets the H-Bridge operation mode.

**Table 7.2 HBMODE function**

HBMODE input	Function
L	Small mode
H	Large mode

Note 1: When using the Large mode, please make sure that the impedance between A channel and B channel is balanced. Also, make sure that the output pins (OUTA+ and OUTA-, OUTB+ and OUTB-), RS pins (RSA and RSB) are connected to each other when using the Large mode.

Note 2: Please set the HBMODE to Low or High with the PCB pattern. (Do not change the logic input level during operation.)

## H-Bridge connection example

- 2 DC motor (Small mode) operation setting example

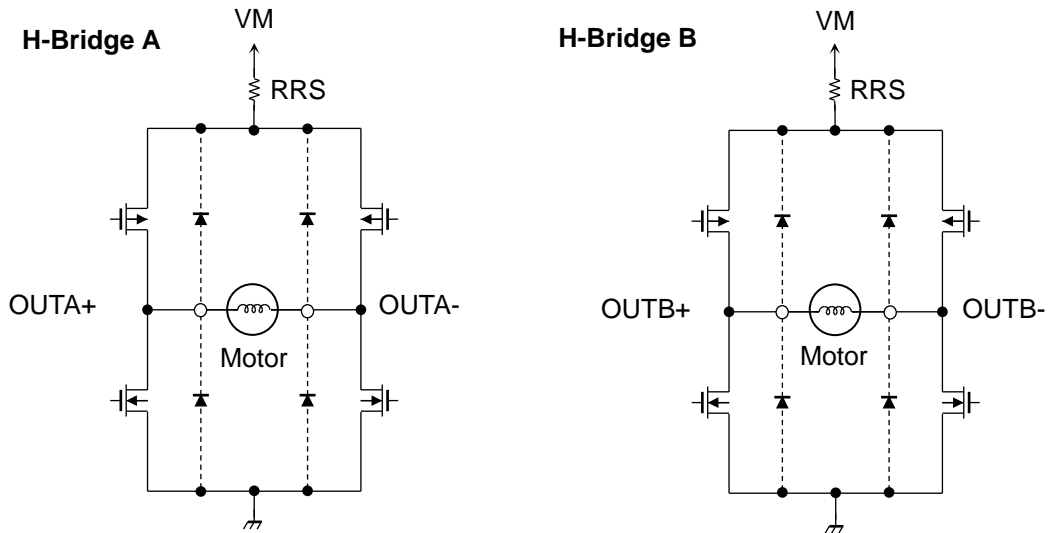

Figure 7.1 2 DC motor (Small mode) operation

- 1 DC motor (Large mode) operation setting example

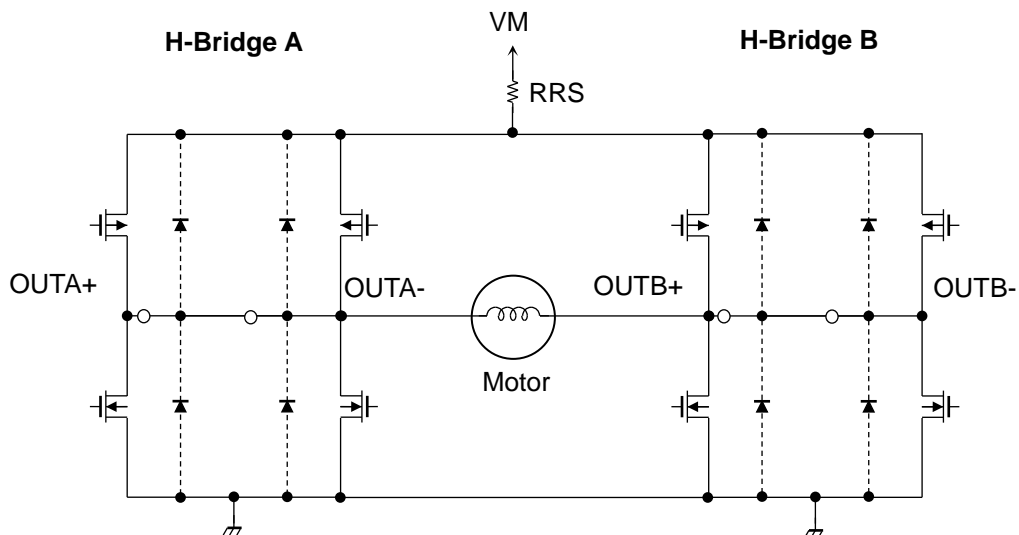

Figure 7.2 1 DC motor (Large mode) operation

Please note that in the equivalent input circuit, functional blocks or constants may be omitted or simplified for explanatory purposes.

## 7.3. Input/output function table

### Small mode

#### (1) INA1, INA2 terminals

This terminal sets the drive mode for Bridge A

**Table 7.3 Function of INA1 and INA2 (Small mode)**

	PWMA	INA1	INA2	OUTA+	OUTA-	Function
Input	L	L	L	OFF (Hi-Z)	OFF (Hi-Z)	STANDBY MODE (*)
	H					STOP(OFF)
	L	L	H	L	L	Short brake
	H					CCW (Counter clock-wise)
	L	H	L	L	L	Short brake
	H					CW (Clock-wise)
	L	H	H	L	L	Short brake
	H					

#### (2) INB1, INB2 terminals

These pins set the drive mode for Bridge B

**Table 7.4 Function of INB1 and INB2 (Small mode)**

	PWMB	INB1	INB2	OUTB+	OUTB-	Function
Input	L	L	L	OFF (Hi-Z)	OFF (Hi-Z)	STANDBY MODE (*)
	H					STOP(OFF)
	L	L	H	L	L	Short brake
	H					CCW (Counter clock-wise)
	L	H	L	L	L	Short brake
	H					CW (Clock-wise)
	L	H	H	L	L	Short brake
	H					

## Large mode

These pins set the drive mode for Bridge A and B by controlling them as one H-bridge

**Table 7.5 Function of INA1 and INA2 (Large mode)**

	PWMA	INA1	INA2	OUTL+	OUTL-	Function
Input	L	L	L	OFF (Hi-Z)	OFF (Hi-Z)	STANDBY MODE (*)
	H					STOP(OFF)
	L	L	H	L	L	Short brake
	H					CCW (Counter clock-wise)
	L	H	L	L	L	Short brake
	H					CW (Clock-wise)
	L	H	H	L	L	Short brake
	H					

In Large mode, the operation is controlled by terminals for Bridge-A (INA1, INA2, and PWMA). Pay attention that signal inputs for Bridge-B (INB1, INB2, and PWMB) are invalid. (In using Large mode, it is recommended to set to low level all terminals of INB1, INB2, and PWMB.) The terminal of TBLKAB is valid whether the terminal of HBMODE is set to low or high level.

\*Note: The standby mode is only enabled when all 6 logic input pins (INA1, INA2, PWMA, INB1, INB2, and PWMB) are set to Low level.

**8. Example of application circuit**

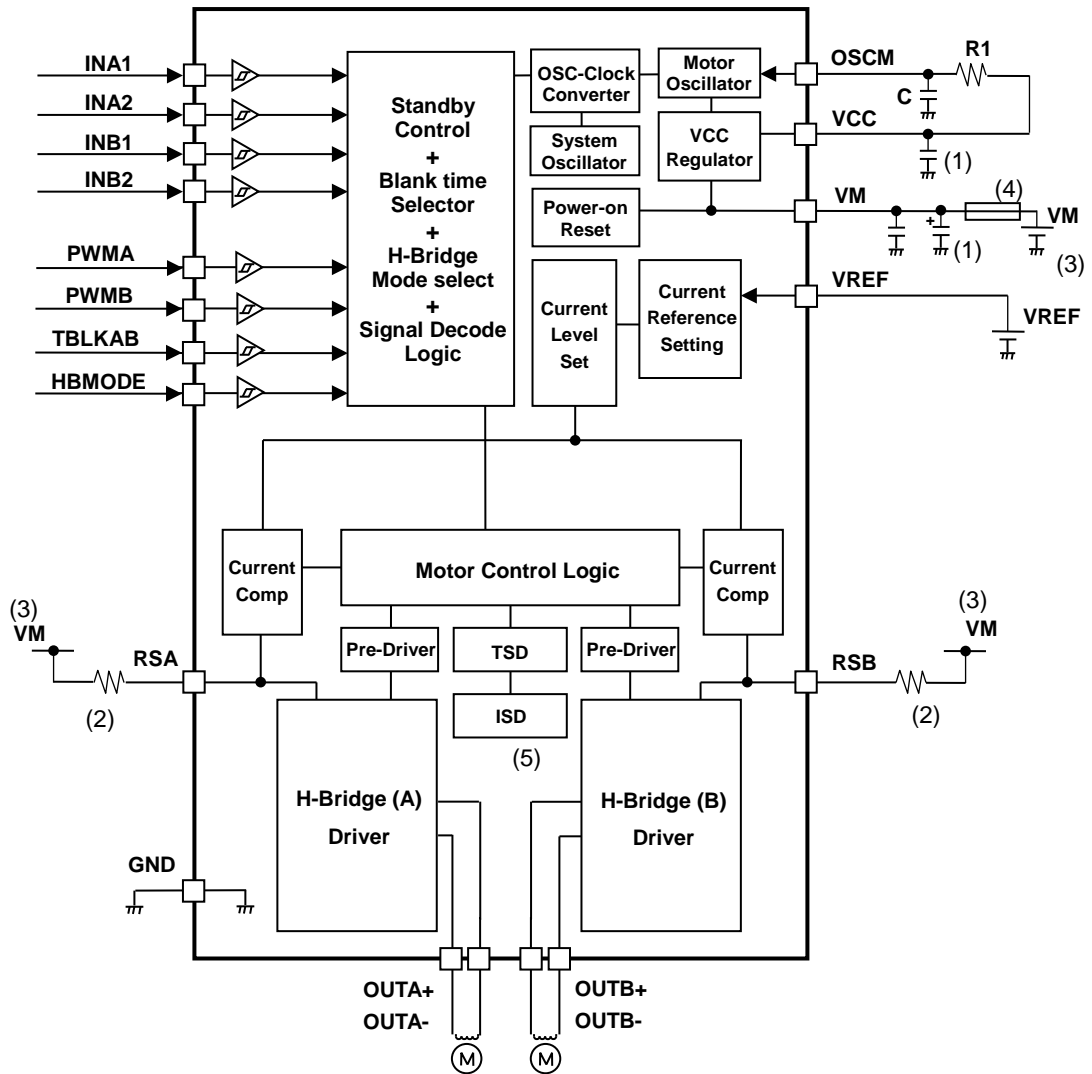

The application circuits shown in this document are provided for reference purposes only. Thorough evaluation is required, especially at the mass-production design stage.

**Figure 8.1 Example of application circuit**

## (1) Capacitor for power supply terminal

To stabilize the power supply voltage of the IC and reduce the noise, connect the appropriate capacitor to each terminal. It is recommended to connect the capacitor as close to the IC as possible. Especially, by connecting the ceramic capacitor near the IC, the change of the power supply at the high frequency range and the noise can be reduced.

**Table 8.1 Recommended capacitor values for power supply terminal**

Item	Parts	Typ.	Recommended range
VM-GND	Electrolytic capacitor	100 μF	47 to 100 μF
	Ceramic capacitor	0.1 μF	0.01 to 1 μF
VCC-GND	Ceramic / Electrolytic capacitor	0.1 μF	0.01 to 1 μF
(VREF-GND)	Ceramic capacitor	0.1 μF	0.01 to 1 μF

\* VREF-GND: Connect the capacitor in necessary depending on the usage environment.

\* It is possible to use the capacitor, which is not the recommended capacitor, depending on the motor load condition and the design pattern of the board.

## (2) Resistance of current detection

This IC configures the threshold of the constant current detection by connecting the resistance of current detection between VM and RS terminals. The detection resistance is recommended to connect near the IC. (The motor can be controlled with the accurate current because the influence of the wire resistance of the board can be reduced.)

**Table 8.2 Recommended resistance values for current detection**

Item	Parts	Typ.	Recommended range
VM-RS	Chip / Lead resistance	0.22 Ω (1.5 to 3.0 A)	0.22 to 1.0 Ω
VM-RS	Chip / Lead resistance	0.51 Ω (0 to 1.5 A)	0.22 to 1.0 Ω

The relation equation of the threshold of the constant current detection, Vref voltage, and the resistance of RS detection is as follows;

$$I_{out(max)} = V_{ref}(gain) \times \frac{V_{ref}(V)}{R_{RS}(\Omega)}$$

Vref (gain): Vref decay ratio is 1 / 5.0(typ.).

As for the resistance of current detection, the constant number which is out of recommended range can be adopted. In this case, please pay attentions to the followings when the used resistance is high and low.

- When the detection resistance is low, the difference voltage between VM and RS comparing to the internal reference voltage becomes small. So, the current may be largely different from the configured current value.
- When the detection resistance is high, the power applied to the detection resistance increases in motor operation ( $P=I^2 \times R$ ). So, in case the same current flows as the case of low resistance, the power dissipation should be larger.



## 9. Power consumption of the IC

Power of the IC is consumed by the transistor of the output block and that of the logic block mainly.

$$P(\text{total}) = P(\text{out}) + P(\text{bias})$$

- **Power consumption of the motor output block**

Power of the output block (P(out)) is consumed by MOSFET of upper and lower H-Bridge.

$$P(\text{out}) = \text{Number of H-Bridge} \times I_{\text{out}} (\text{A}) \times V_{\text{DS}} (\text{V}) = 2 (\text{ch}) \times I_{\text{out}} (\text{A}) \times I_{\text{out}} (\text{A}) \times R_{\text{on}} (\Omega) \dots\dots\dots(1)$$

When the current waveform of the motor output corresponds to the ideal waveform, average power of output block can be provided as follows;

When  $R_{\text{on}} = 0.49\Omega$ ,  $I_{\text{out}} (\text{peak: Max}) = 1.5 \text{ A}$ ,  $V_{\text{M}} = 24 \text{ V}$

$$P(\text{out}) = 2 (\text{ch}) \times 1.5 (\text{A}) \times 1.5 (\text{A}) \times 0.49 (\Omega) \dots\dots\dots (2) \\ = 2.205 (\text{W})$$

- **Power consumption of logic and IM systems.**

Power consumptions of logic and IM systems are calculated by separating the states (operating and stopping).

- I (IM3) = 5.5 mA (typ.) : Operating
- I (IM2) = 3.5 mA (typ.) : Stopping

Output system is connected to VM (24V). (Output system: Current consumed by the circuit connected to VM + Current consumed by switching output steps)

Power consumption is calculated as follows;

$$P(\text{bias}) = 24 (\text{V}) \times 0.0055 (\text{A}) \dots\dots\dots (3) \\ = 0.132 (\text{W})$$

- **Power consumption**

Total power consumption P(total) is calculated from the values of formula (2) and (3).

$$P(\text{total}) = P(\text{out}) + P(\text{bias}) = 2.205 + 0.132 = 2.337 (\text{W})$$

Standby mode is released. The power consumption in non-operation mode of the motor (waiting mode) is calculated as follows;

$$P = 24 (\text{V}) \times 0.0035 (\text{A}) = 0.084 (\text{W})$$

In actual motor operation, the average current becomes lower than the calculated value because of transition time of the current steps and the ripple of the constant current PWM. Refer to the above equations, evaluate the heat design of the board by the actual board enough, and configure the appropriate margin.



## 10. Power dissipation

Relation equation of the ambient temperature ( $T_a$ ), junction temperature ( $T_j$ ), and the heat resistance ( $R_{th(j-a)}$ ) between junction temperature to ambient temperature is as follows;

$$T_j = T_a + P \times R_{th(j-a)}$$

(Example) When 4-layer mounting board ( $R_{th(j-a)} = 25^\circ\text{C/W}$ ),  $T_a = 25^\circ\text{C}$ ,  $P(\text{total}) = 2.337\text{ W}$  ( $I_{out} = 1.5\text{ A}$ , 2-phase excitation)

$$T_j = 25\text{ (}^\circ\text{C)} + 2.337\text{ (W)} \times 25\text{ (}^\circ\text{C/W)} = 83.425^\circ\text{C}$$

(Reference) Relation between the power dissipation and the ambient temperature

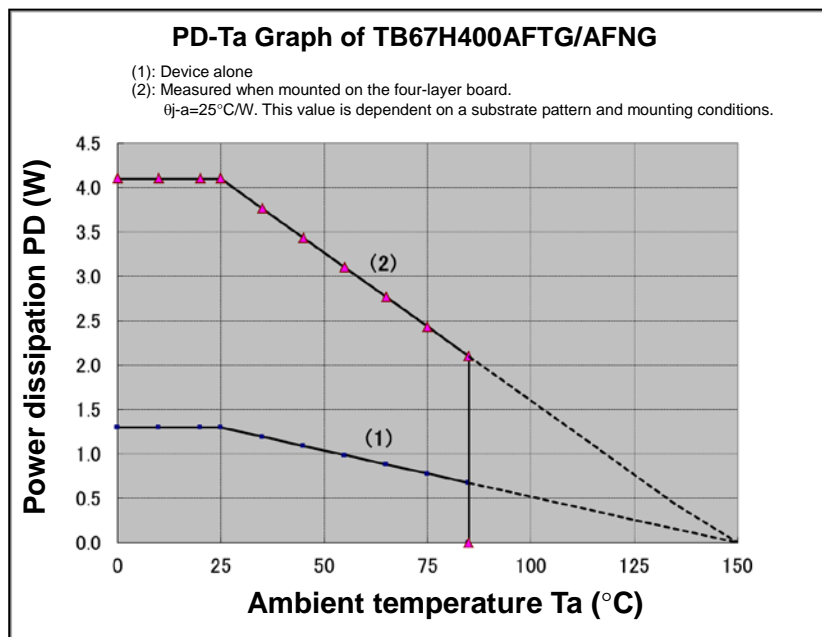

Figure 10.1 Power dissipation

※ Pay attention that  $T_a$ ,  $R_{th(j-a)}$ , and  $P(\text{total})$  depend on the usage environment. When ambient temperature is high, the allowable power consumption decreases.

## 11. Example of reference foot pattern

### (1) QFN48 foot pattern (unit: mm)

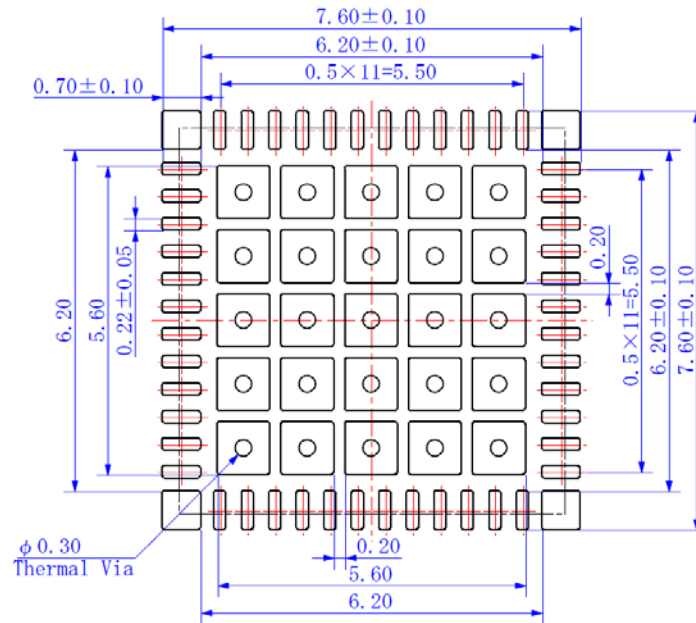

Figure 11.1 QFN48 foot pattern

### (2) HTSSOP48 foot pattern (unit: mm)

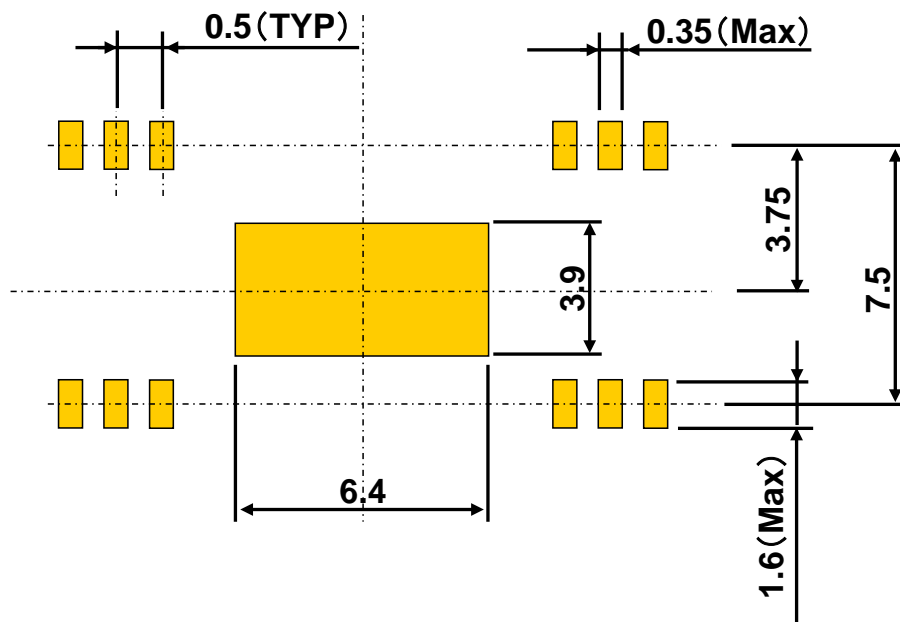

Figure 11.2 HTSSOP48 foot pattern

Toshiba does not guarantee the data for mass production. Please use the data as reference data for customer's application.

Note: In determining the size of mounting board, design the most appropriate pattern by considering the solder bridge, the solder connecting strength, the pattern accuracy in making board, the heat sink of leads, and the mounting accuracy of the IC board.

## 12. Board dimensions

### 12.1. Input

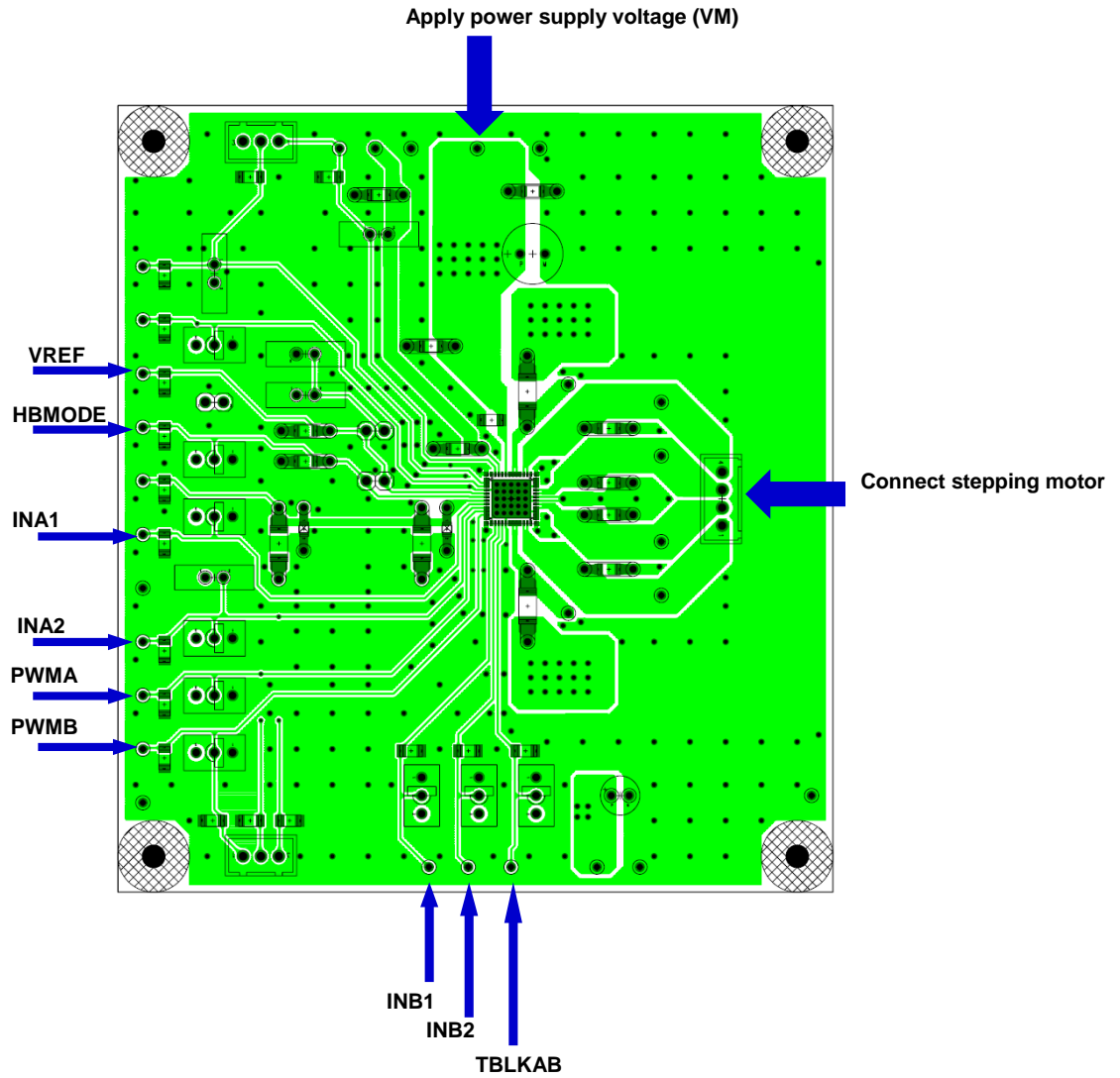

Figure 12.1 Input

Input each power supply and control signal according to above figure.

## 12.2. Main part

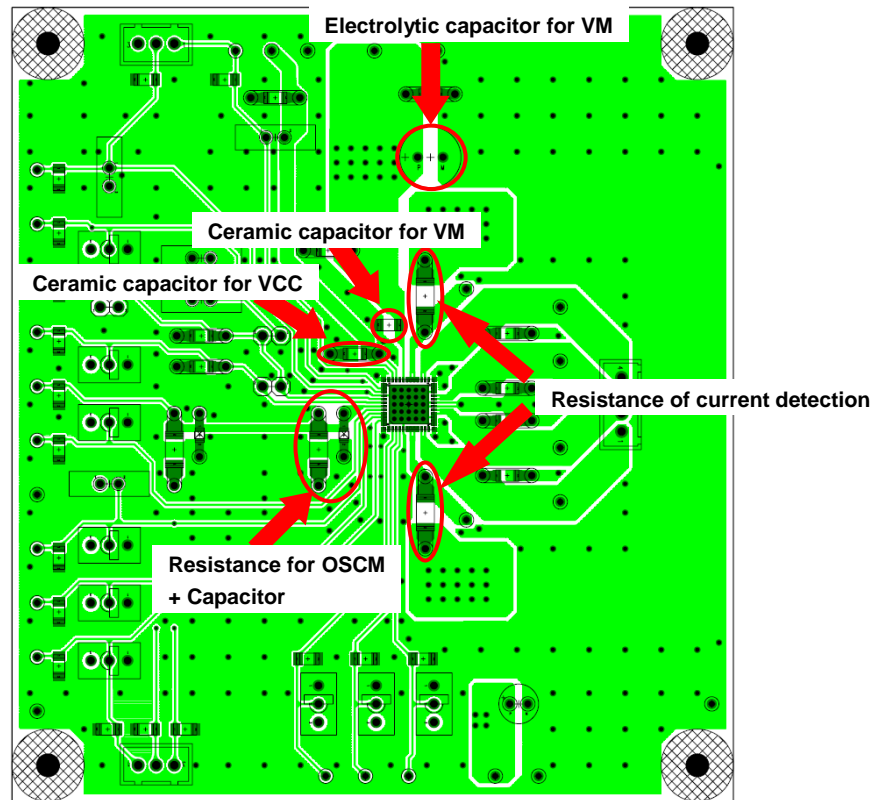

Figure 12.2 Main part

Connect each part referring to "8.Example of application circuit".

## 12.3. Options

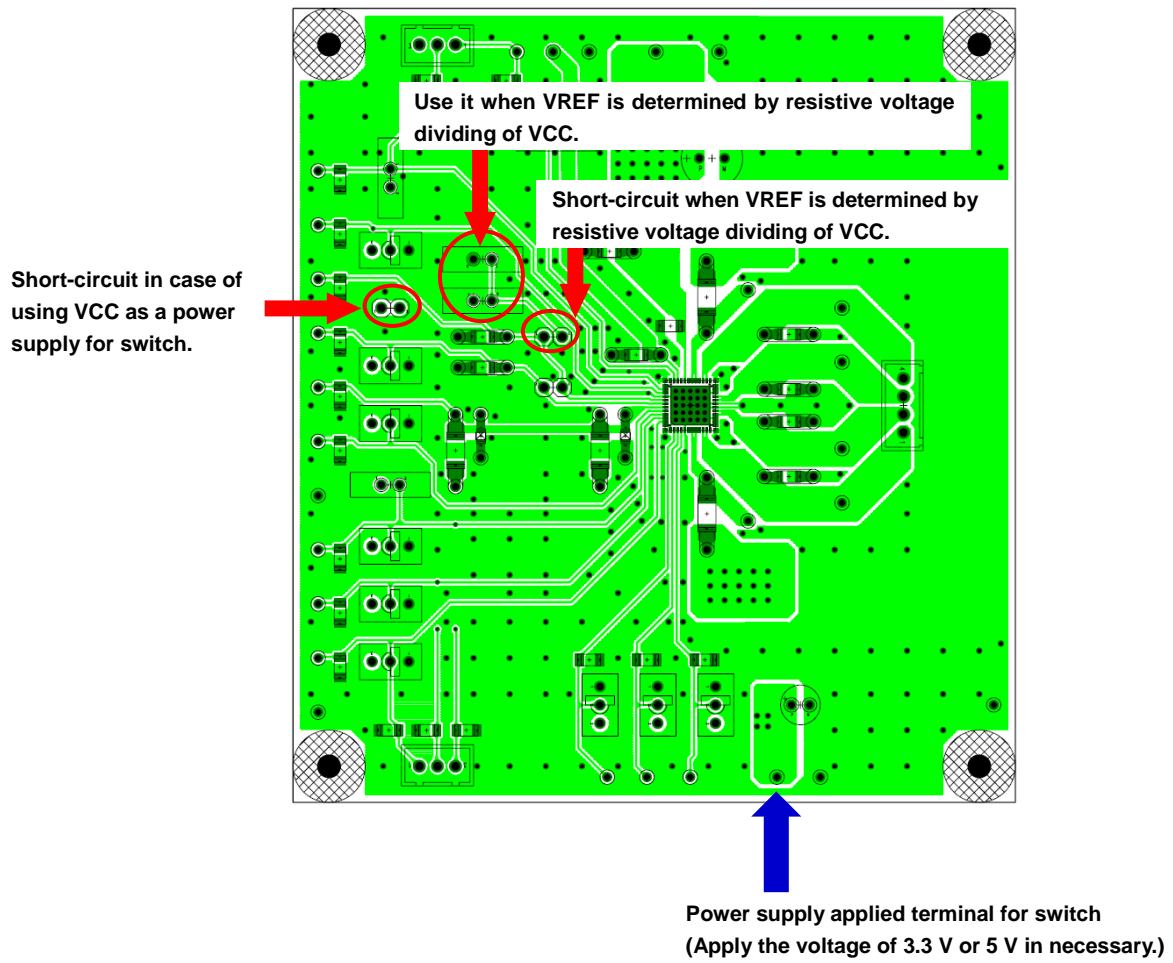

Figure 12.3 Options

## Notes on Contents

### 1. Block Diagrams

Some of the functional blocks, circuits, or constants in the block diagram may be omitted or simplified for explanatory purposes.

### 2. Equivalent Circuits

The equivalent circuit diagrams may be simplified or some parts of them may be omitted for explanatory purposes.

### 3. Timing Charts

Timing charts may be simplified for explanatory purposes.

### 4. Application Circuits

The application circuits shown in this document are provided for reference purposes only. Thorough evaluation is required, especially at the mass production design stage.

Toshiba does not grant any license to any industrial property rights by providing these examples of application circuits.

### 5. Test Circuits

Components in the test circuits are used only to obtain and confirm the device characteristics. These components and circuits are not guaranteed to prevent malfunction or failure from occurring in the application equipment.

## IC Usage Considerations

### Notes on handling of ICs

- (1) The absolute maximum ratings of a semiconductor device are a set of ratings that must not be exceeded, even for a moment. Do not exceed any of these ratings.  
Exceeding the rating(s) may cause the device breakdown, damage or deterioration, and may result injury by explosion or combustion.
- (2) Use an appropriate power supply fuse to ensure that a large current does not continuously flow in case of over current and/or IC failure. The IC will fully break down when used under conditions that exceed its absolute maximum ratings, when the wiring is routed improperly or when an abnormal pulse noise occurs from the wiring or load, causing a large current to continuously flow and the breakdown can lead smoke or ignition. To minimize the effects of the flow of a large current in case of breakdown, appropriate settings, such as fuse capacity, fusing time and insertion circuit location, are required.
- (3) If your design includes an inductive load such as a motor coil, incorporate a protection circuit into the design to prevent device malfunction or breakdown caused by the current resulting from the inrush current at power ON or the negative current resulting from the back electromotive force at power OFF. IC breakdown may cause injury, smoke or ignition.  
Use a stable power supply with ICs with built-in protection functions. If the power supply is unstable, the protection function may not operate, causing IC breakdown. IC breakdown may cause injury, smoke or ignition.
- (4) Do not insert devices in the wrong orientation or incorrectly.  
Make sure that the positive and negative terminals of power supplies are connected properly. Otherwise, the current or power consumption may exceed the absolute maximum rating, and exceeding the rating(s) may cause the device breakdown, damage or deterioration, and may result injury by explosion or combustion.  
In addition, do not use any device that is applied the current with inserting in the wrong orientation or incorrectly even just one time.
- (5) Carefully select external components (such as inputs and negative feedback capacitors) and load components (such as speakers), for example, power amp and regulator.  
If there is a large amount of leakage current such as input or negative feedback condenser, the IC output DC voltage will increase. If this output voltage is connected to a speaker with low input withstand voltage, overcurrent or IC failure can cause smoke or ignition. (The over current can cause smoke or ignition from the IC itself.) In particular, please pay attention when using a Bridge Tied Load (BTL) connection type IC that inputs output DC voltage to a speaker directly.

**Points to remember on handling of ICs****(1) Over current Protection Circuit**

Over current protection circuits (referred to as current limiter circuits) do not necessarily protect ICs under all circumstances. If the over current protection circuits operate against the over current, clear the over current status immediately.

Depending on the method of use and usage conditions, such as exceeding absolute maximum ratings can cause the over current protection circuit to not operate properly or IC breakdown before operation. In addition, depending on the method of use and usage conditions, if over current continues to flow for a long time after operation, the IC may generate heat resulting in breakdown.

**(2) Thermal Shutdown Circuit**

Thermal shutdown circuits do not necessarily protect ICs under all circumstances. If the thermal shutdown circuits operate against the over temperature, clear the heat generation status immediately.

Depending on the method of use and usage conditions, such as exceeding absolute maximum ratings can cause the thermal shutdown circuit to not operate properly or IC breakdown before operation.

**(3) Heat Radiation Design**

In using an IC with large current flow such as power amp, regulator or driver, please design the device so that heat is appropriately radiated, not to exceed the specified junction temperature ( $T_j$ ) at any time and condition. These ICs generate heat even during normal use. An inadequate IC heat radiation design can lead to decrease in IC life, deterioration of IC characteristics or IC breakdown. In addition, please design the device taking into consideration the effect of IC heat radiation with peripheral components.

**(4) Back-EMF**

When a motor rotates in the reverse direction, stops or slows down abruptly, a current flow back to the motor's power supply due to the effect of back-EMF. If the current sink capability of the power supply is small, the device's motor power supply and output pins might be exposed to conditions beyond absolute maximum ratings. To avoid this problem, take the effect of back-EMF into consideration in system design.

---

## RESTRICTIONS ON PRODUCT USE

Toshiba Corporation and its subsidiaries and affiliates are collectively referred to as "TOSHIBA".  
Hardware, software and systems described in this document are collectively referred to as "Product".

- TOSHIBA reserves the right to make changes to the information in this document and related Product without notice.
- This document and any information herein may not be reproduced without prior written permission from TOSHIBA. Even with TOSHIBA's written permission, reproduction is permissible only if reproduction is without alteration/omission.
- Though TOSHIBA works continually to improve Product's quality and reliability, Product can malfunction or fail. Customers are responsible for complying with safety standards and for providing adequate designs and safeguards for their hardware, software and systems which minimize risk and avoid situations in which a malfunction or failure of Product could cause loss of human life, bodily injury or damage to property, including data loss or corruption. Before customers use the Product, create designs including the Product, or incorporate the Product into their own applications, customers must also refer to and comply with (a) the latest versions of all relevant TOSHIBA information, including without limitation, this document, the specifications, the data sheets and application notes for Product and the precautions and conditions set forth in the "TOSHIBA Semiconductor Reliability Handbook" and (b) the instructions for the application with which the Product will be used with or for. Customers are solely responsible for all aspects of their own product design or applications, including but not limited to (a) determining the appropriateness of the use of this Product in such design or applications; (b) evaluating and determining the applicability of any information contained in this document, or in charts, diagrams, programs, algorithms, sample application circuits, or any other referenced documents; and (c) validating all operating parameters for such designs and applications. **TOSHIBA ASSUMES NO LIABILITY FOR CUSTOMERS' PRODUCT DESIGN OR APPLICATIONS.**
- **PRODUCT IS NEITHER INTENDED NOR WARRANTED FOR USE IN EQUIPMENTS OR SYSTEMS THAT REQUIRE EXTRAORDINARILY HIGH LEVELS OF QUALITY AND/OR RELIABILITY, AND/OR A MALFUNCTION OR FAILURE OF WHICH MAY CAUSE LOSS OF HUMAN LIFE, BODILY INJURY, SERIOUS PROPERTY DAMAGE AND/OR SERIOUS PUBLIC IMPACT ("UNINTENDED USE").** Except for specific applications as expressly stated in this document, Unintended Use includes, without limitation, equipment used in nuclear facilities, equipment used in the aerospace industry, medical equipment, equipment used for automobiles, trains, ships and other transportation, traffic signaling equipment, equipment used to control combustions or explosions, safety devices, elevators and escalators, devices related to electric power, and equipment used in finance-related fields. **IF YOU USE PRODUCT FOR UNINTENDED USE, TOSHIBA ASSUMES NO LIABILITY FOR PRODUCT.** For details, please contact your TOSHIBA sales representative.
- Do not disassemble, analyze, reverse-engineer, alter, modify, translate or copy Product, whether in whole or in part.
- Product shall not be used for or incorporated into any products or systems whose manufacture, use, or sale is prohibited under any applicable laws or regulations.
- The information contained herein is presented only as guidance for Product use. No responsibility is assumed by TOSHIBA for any infringement of patents or any other intellectual property rights of third parties that may result from the use of Product. No license to any intellectual property right is granted by this document, whether express or implied, by estoppel or otherwise.
- **ABSENT A WRITTEN SIGNED AGREEMENT, EXCEPT AS PROVIDED IN THE RELEVANT TERMS AND CONDITIONS OF SALE FOR PRODUCT, AND TO THE MAXIMUM EXTENT ALLOWABLE BY LAW, TOSHIBA (1) ASSUMES NO LIABILITY WHATSOEVER, INCLUDING WITHOUT LIMITATION, INDIRECT, CONSEQUENTIAL, SPECIAL, OR INCIDENTAL DAMAGES OR LOSS, INCLUDING WITHOUT LIMITATION, LOSS OF PROFITS, LOSS OF OPPORTUNITIES, BUSINESS INTERRUPTION AND LOSS OF DATA, AND (2) DISCLAIMS ANY AND ALL EXPRESS OR IMPLIED WARRANTIES AND CONDITIONS RELATED TO SALE, USE OF PRODUCT, OR INFORMATION, INCLUDING WARRANTIES OR CONDITIONS OF MERCHANTABILITY, FITNESS FOR A PARTICULAR PURPOSE, ACCURACY OF INFORMATION, OR NONINFRINGEMENT.**
- Do not use or otherwise make available Product or related software or technology for any military purposes, including without limitation, for the design, development, use, stockpiling or manufacturing of nuclear, chemical, or biological weapons or missile technology products (mass destruction weapons). Product and related software and technology may be controlled under the applicable export laws and regulations including, without limitation, the Japanese Foreign Exchange and Foreign Trade Law and the U.S. Export Administration Regulations. Export and re-export of Product or related software or technology are strictly prohibited except in compliance with all applicable export laws and regulations.
- Please contact your TOSHIBA sales representative for details as to environmental matters such as the RoHS compatibility of Product. Please use Product in compliance with all applicable laws and regulations that regulate the inclusion or use of controlled substances, including without limitation, the EU RoHS Directive. **TOSHIBA ASSUMES NO LIABILITY FOR DAMAGES OR LOSSES OCCURRING AS A RESULT OF NONCOMPLIANCE WITH APPLICABLE LAWS AND REGULATIONS.**