

TOSHIBA CMOS Digital Integrated Circuit Silicon Monolithic

TC90107FG

Single Channel Video Decoder

The TC90107FG is a single chip IC that converts analog video signal to digital video signal. (ITU-R BT.656)

Additionally, the TC90107FG has one 10bit ADC as analog input interface, and has one 3-line Y/C separation, and multi-system color decoder.

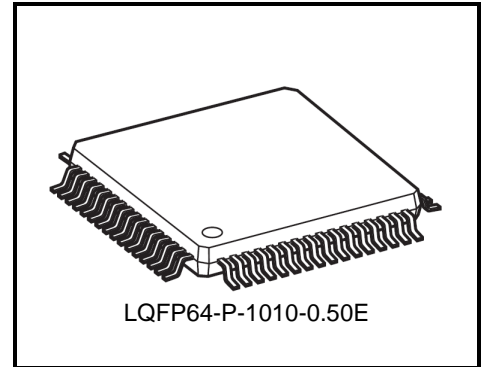

Weight: 0.40 g (typ.)

1. Features

1. Analog Video signal Input : CVBS
2. Adaptive multi-color decoder (1ch)
3. Sync processing / Video system detection
4. 10bit ADC (1ch)
5. Analog AGC (Sync AGC + Peak AGC)
6. LPF circuit for input analog video signal
7. Y/C separation: 3-line YCS (NTSC/PAL)
Band Pass Filter (SECAM)
8. Picture process
Y: HV enhance, V enhance, LTI, sharpness, noise cancel, Dynamic gamma correction, Static gamma correction
Contrast, Brightness
C: TOF, ACC, Color gain, Color offset, CTI, noise cancel, Tint, Color management, Color gain correction linked to Y-gamma
9. Function Horizontal aberration correction, Data slice(WSS / Video-ID / CC), S/N detection
10. Digital Video signal output: ITU-R BT.656
11. I²C-bus control
12. Regulator circuit (3.3 V input / 2.5 V output)
13. Package: LQFP 64 Pin (0.50 mm pitch)
14. Power supply: 3.3 V, 2.5 V, 1.5 V
15. Operation temperature: -40°C to 85°C

2. Block Diagram

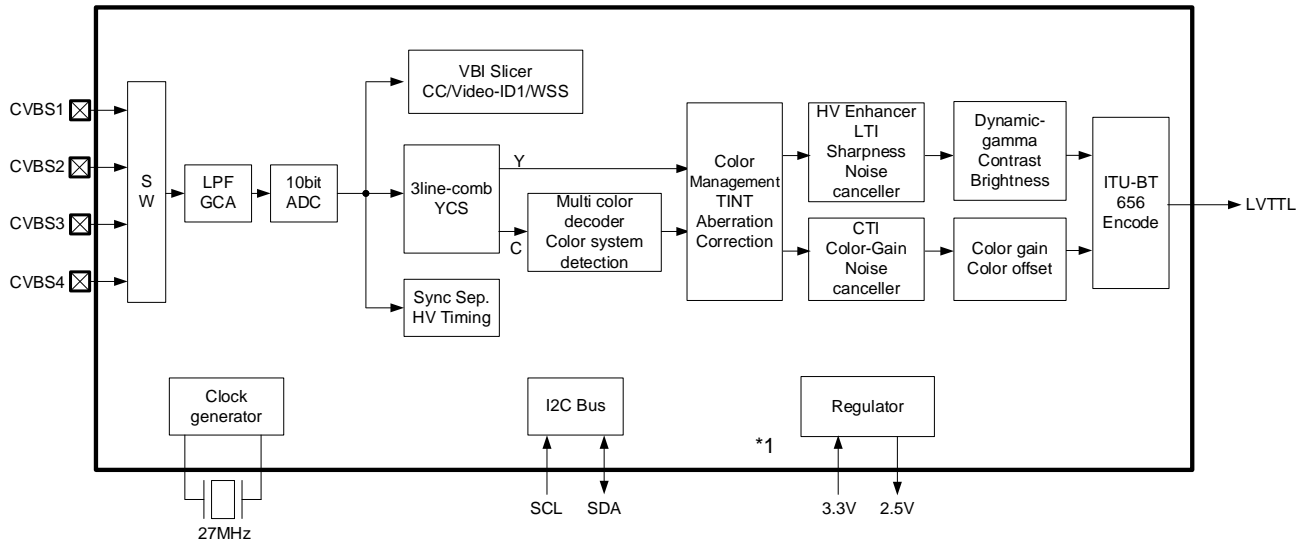

*1: Regulator output 2.5 V is not connected in the inside of IC.
 When it use built in Regurator, it connected on board.

3. Pin Layout

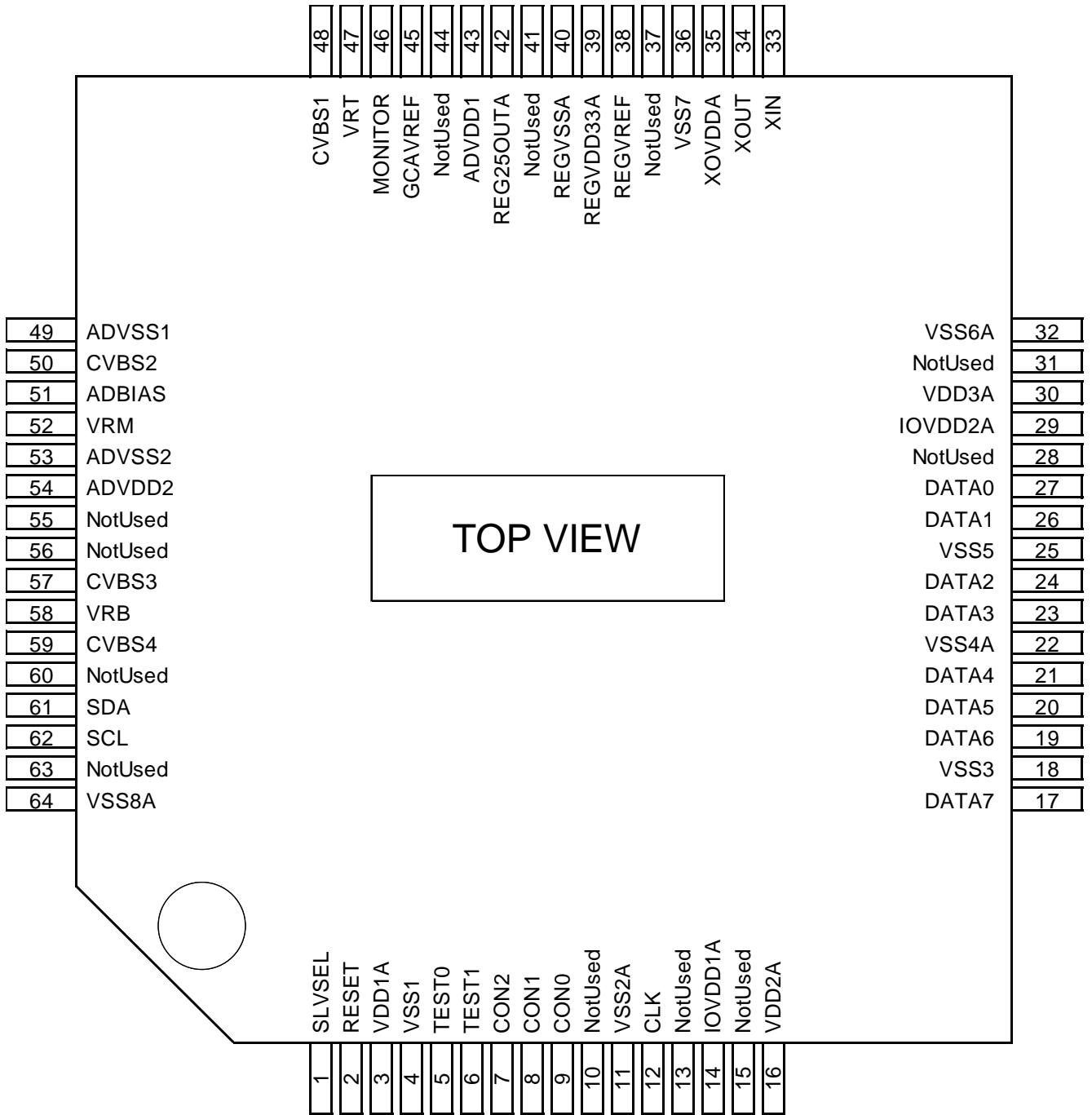

4. Pin Description

No.	Pin Name	I/O	Function	Tolerable Voltage [V]	Circuit	Treatment when not in use
1	SLVSEL	I	I ² C slave address select	3.3	Digital	Full-time use
2	RESET	I	System Reset (Reset is Low.)	5	Digital	GND
3	VDD1A	DVDD	Power supply for Logic: 1.5V	1.5	Digital	1.5 V
4	VSS1	DVSS	GND for Logic	0	Digital	GND
5	TEST0	I	Test Terminal 0	3.3	Digital	GND
6	TEST1	I	Test Terminal 1	3.3	Digital	GND
7	CON2	O	Timing Pulse Output 2	3.3	Digital	Open
8	CON1	O	Timing Pulse Output 1	3.3	Digital	Open
9	CON0	O	Timing Pulse Output 0	3.3	Digital	Open
10	NotUsed	N.C.	Not connect	-	Digital	Full-time open
11	VSS2A	DVSS	GND for Logic	0	Digital	GND
12	CLK	O	CLK Output	3.3	Digital	Open
13	NotUsed	N.C.	Not connect	-	Digital	Full-time open
14	IOVDD1A	IOVDD33	Power supply for IO: 3.3 V	3.3	Digital	3.3 V
15	NotUsed	N.C.	Not connect	-	Digital	Full-time open
16	VDD2A	DVDD	Power supply for Logic: 1.5 V	1.5	Digital	1.5 V
17	DATA7	O	Digital data output 7	3.3	Digital	Open
18	VSS3	DVSS	GND for Logic	0	Digital	GND
19	DATA6	O	Digital data output 6	3.3	Digital	Open
20	DATA5	O	Digital data output 5	3.3	Digital	Open
21	DATA4	O	Digital data output 4	3.3	Digital	Open
22	VSS4A	DVSS	GND for Logic	0	Digital	GND
23	DATA3	O	Digital data output 3	3.3	Digital	Open
24	DATA2	O	Digital data output 2	3.3	Digital	Open
25	VSS5	DVSS	GND for Logic	0	Digital	GND
26	DATA1	O	Digital data output 1	3.3	Digital	Open
27	DATA0	O	Digital data output 0	3.3	Digital	Open
28	NotUsed	N.C.	Not connect	-	Digital	Full-time open
29	IOVDD2A	IOVDD33	Power supply for IO: 3.3 V	3.3	Digital	3.3 V
30	VDD3A	DVDD	Power supply for Logic: 1.5 V	1.5	Digital	1.5 V
31	NotUsed	N.C.	Not connect	-	Digital	Full-time open
32	VSS6A	DVSS	GND for Logic	0	Digital	GND

No.	Pin Name	I/O	Function	Tolerable Voltage [V]	Circuit	Treatment when not in use
33	XIN	I	X'tal OSC circuit input terminal	3.3	Digital	Full-time use
34	XOUT	O	X'tal OSC circuit output terminal	3.3	Digital	Full-time use
35	XOVDDA	XOVDD	Power supply for X'tal: 3.3 V	3.3	Digital	2.5 V or 3.3 V
36	VSS7	DVSS	GND for Logic	0	Digital	GND
37	NotUsed	N.C.	Not connect	-	Digital	Open
38	REGVREF	BIAS	Voltage relay for Internal Regulator	2.5	analog	GND via 0.1 μ F
39	REGVDD33A	AVDD33	Power supply for Internal Regulator (for ADC block)	3.3	analog	3.3 V
40	REGVSSA	AVSS	Analog GND for Internal Regulator	0	analog	GND
41	NotUsed	N.C.	Not connect	-	Digital	Full-time open
42	REG25OUTA	O	Output of Internal Regulator (For ADC)	2.5	analog	Open
43	ADVDD1	AVDD25	Power supply for ADC&GCA: 2.5 V	2.5	analog	2.5 V
44	NotUsed	N.C.	Not connect	-	Digital	Full-time open
45	GCAVREF	BIAS	Reference voltage output for GCA	2.5	analog	GND via 0.1 μ F
46	MONITOR	O	Monitor terminal for GCA	2.5	analog	Full-time open
47	VRT	BIAS	Reference top voltage of ADC	2.5	analog	Full-time use
48	CVBS1	I	CVBS input 1	2.5	analog	Open
49	ADVSS1	AVSS	Analog GND for ADC/GCA	0	analog	GND
50	CVBS2	I	CVBS input 2	2.5	analog	Open
51	ADBIAS	BIAS	Reference voltage of ADC	2.5	analog	Full-time use
52	VRM	BIAS	Reference middle voltage of ADC	2.5	analog	Full-time use
53	ADVSS2	AVSS	Analog GND for ADC/GCA	0	analog	GND
54	ADVDD2	AVDD25	Power supply for ADC&GCA: 2.5 V	2.5	analog	2.5 V
55	NotUsed	N.C.	Not connect	-	Digital	Full-time open
56	NotUsed	N.C.	Not connect	-	Digital	Full-time open
57	CVBS3	I	CVBS input 3	2.5	analog	Open
58	VRB	BIAS	Reference bottom voltage of ADC	2.5	analog	Full-time use
59	CVBS4	I	CVBS input 4	2.5	analog	Open
60	NotUsed	N.C.	Not connect	-	Digital	Full-time open
61	SDA	I/O	I ² C DATA input	5	Digital	Full-time use
62	SCL	I	I ² C CLOCK input	5	Digital	Full-time use
63	NotUsed	N.C.	Not connect	-	Digital	Open
64	VSS8A	DVSS	GND for Logic	0	Digital	GND

5. Function

- Multi-color decoder
- Output format is ITU-R BT.656
- The TC90107FG has many video quality improving function, such as HVD-Enhancer, dynamic-gamma, color-management and so on.
- Horizontal nonlinearly scaling (horizontal fish-eye correction, horizontal trapezoid correction and so on)
- VBI data slicer function (Closed caption, Video-ID and WSS are available.)
- Regulator circuit (3.3 V input / 2.5 V output) for ADC circuit by external connection.

5.1 Analog video signal input

5.1.1 Analog video signal input amplitude level

The TC90107FG has one 10bit ADC for 1ch CVBS input.

The dynamic range of this ADC is designed in $AVDD \cdot 0.4$ with the normal input dynamic range being 1 Vp-p ($AVDD = 2.5 V$).

Be sure to use 0.7 Vp-p with 140IRE input when using CVBS as the recommended reference input amplitude.

The TC90107FG has AGC function for CVBS input: however, to use the AGC cover range effectively we recommend that you use 0.7 Vp-p with 140IRE input for the input amplitude.

5.1.2 Analog video signal reference input level

1) Reference input level for Composite Video signal when 100% white (i.e. composite video input)

Composite Video signal input level (Ex: 75% color bar)

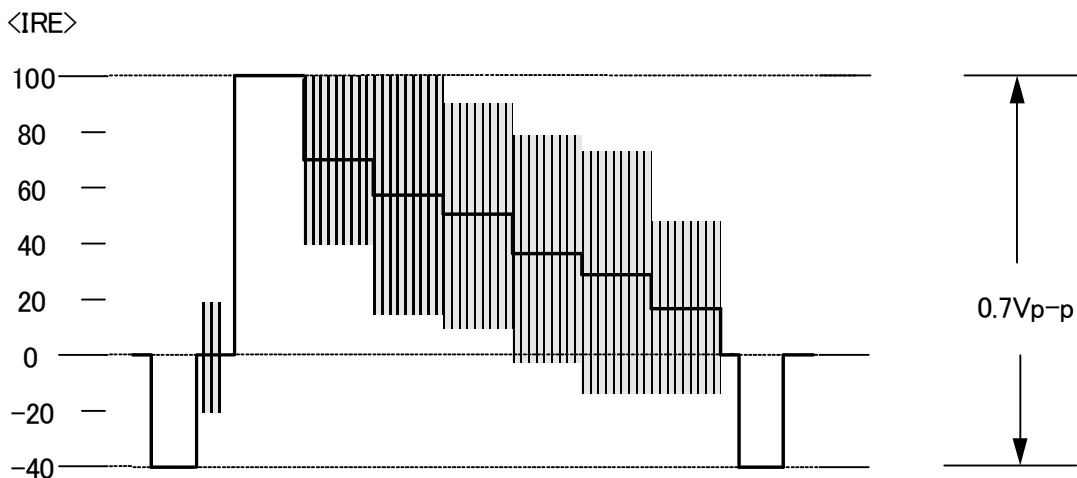

5.1.3 AGC (Auto Gain Control) function

AGC function is used for composite video signal by GCA (Gain control amp) circuit and digital AGC function.

AGC function has two mode: AUTO gain mode and manual gain mode.

It is possible to use 1.0 Vp-p input amplitude by GCA function.

5.1.4 LPF function

TC90107FG has LPF for anti-aliasing in front of GCA block. It is possible to select ON or through mode.

- System : Fourth-order Butterworth filter
- Frequency characteristic : -1 dB@6 MHz, -14 dB@13.5 MHz

5.2 Digital output signal (Outsel Block)

5.2.1 Output signal format

The TC90107FG output is the ITU-R BT.656.
 Pedestal level for Y signal is 16 LSB.
 Center level for Cb and Cr signal is 128 LSB.

*** NOTICE**

TC90107FG use the free-run clock system.
 Therefore, The number of sample between EAV and SAV occur the increase and decrease.
 It must take the data from SAV start. If mistake , It will occur the jitter.
 You must design , it is not affected by the number of sample in blanking.

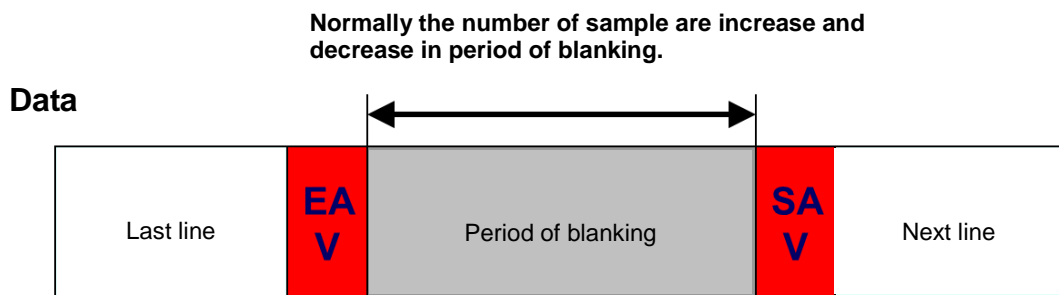

- The system needs not to affect in irregular EAV and SAV about ITU-R BT.656.
 The uptake start of picture must be SAV.
- When it is not suitable for ITU-R BT.656, it deeds to confirm in combination with the following signals.
 - 1) HD
 - 2) VD
 - 3) Data Enable
 - 4) Field Flag (ODD/EVEN)
 - 5) U/V Flag (CbCr select)

TC90107FG can output three timing signals chosen by register at timing output terminal(CON[2:0]).

5.2.1.1. Input of 525i/60Hz

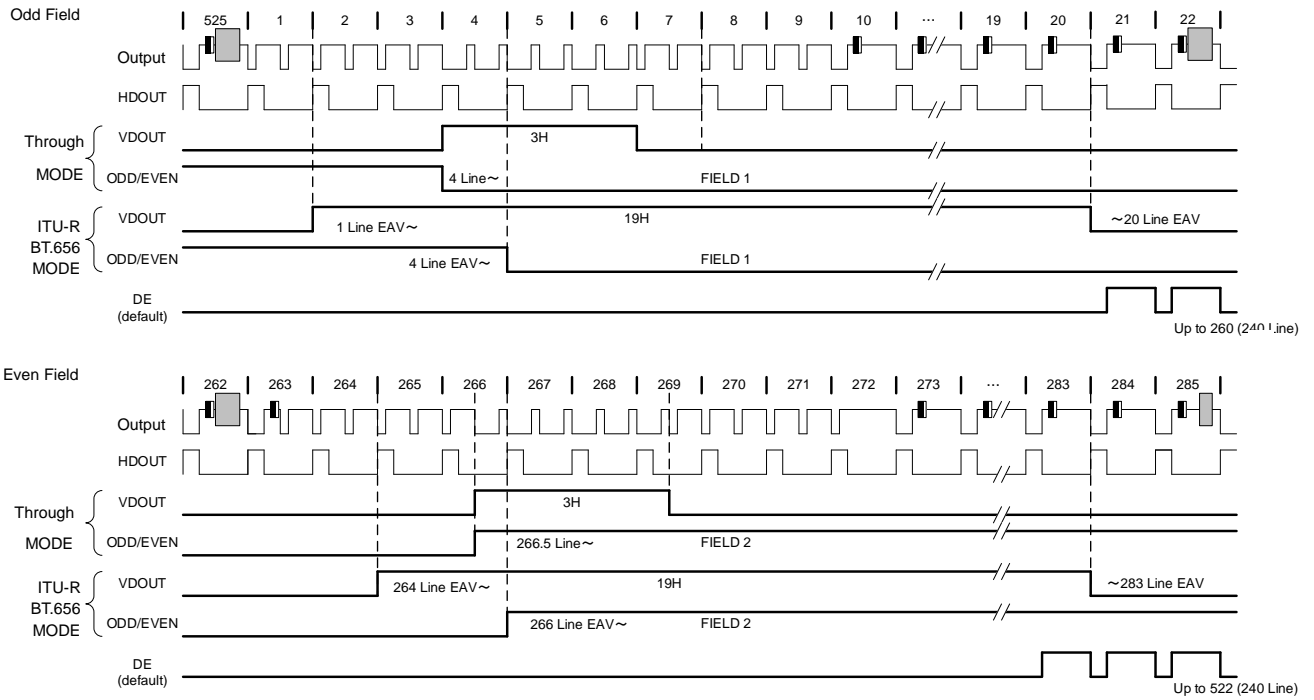

5.2.1.2. Input of 625i/50Hz

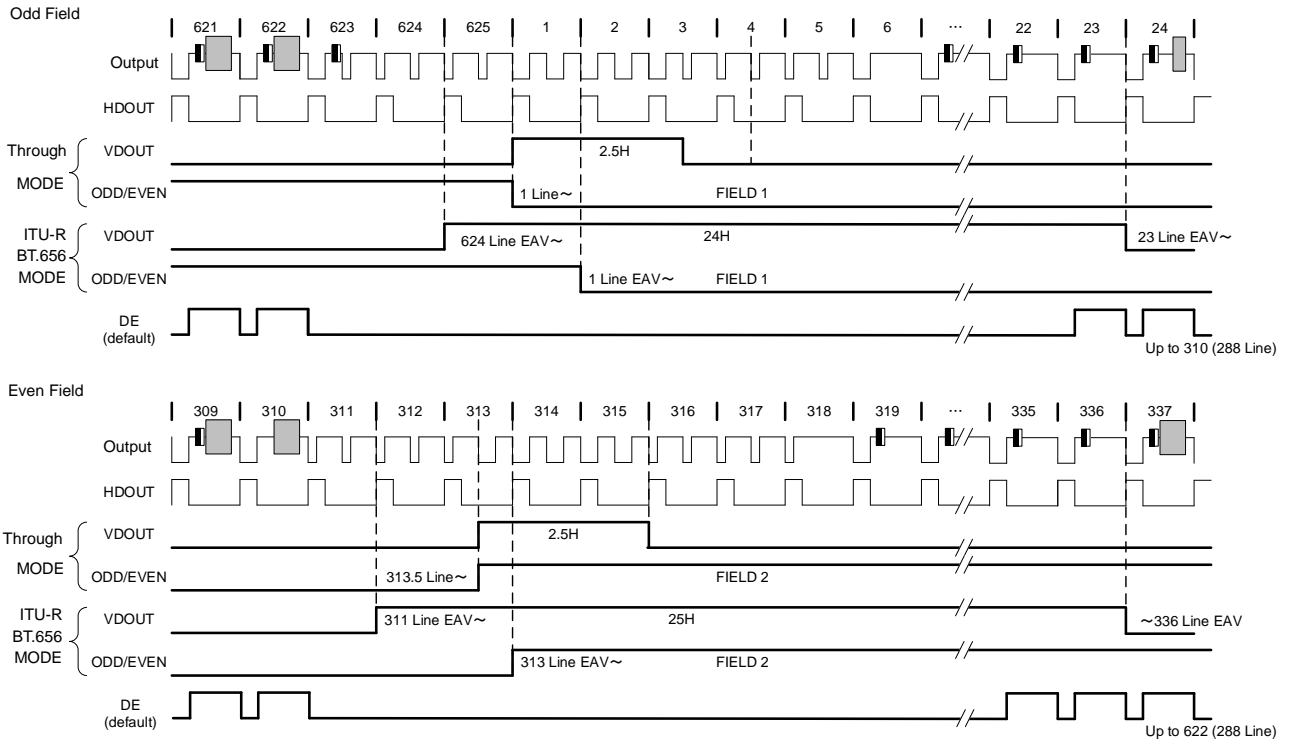

5.2.2 Timing pulse output

CON[2:0] pin (terminal No.7, 8, 9) are output terminal. Output signal can select by register.

1. DE (Data Enable) signal
 DE indicates horizontal and vertical enable picture area for output video signal.
 DE signal is the signal that is HIGH status at active video period, and LOW status at blanking period.
2. HD signal
 HD signal indicates the horizontal sync pulse synchronized with output video signal.
 Setting : pulse width, pulse polarity, phase delay
3. VD signal
 VD signal indicates the vertical sync pulse synchronized with output video signal.
 Setting : pulse width, pulse polarity, phase delay
4. FIELD signal
 FIELD signal indicates ODD/EVEN switch pulse synchronized with output video signal.
 Field signal is the signal that is HIGH status at even field, and LOW status at odd field, when default setting.
 Polarity of FIELD signal inverts by register [FLDO_POLE].
5. UVFLG signal
 UVFLG signal indicates Cb/Cr switch pulse for 4:2:2 format signal.
 Polarity of UVFLG signal inverts by register [UVREV].

5.3 Regulator circuit

The regulator circuit of 2.5 V output (3.3 V input) for ADC circuit is built in IC.

To use regulator output voltage, it is necessary to connect the output terminal of regulator circuit to the power supply input terminal of an ADC circuit in IC exterior.

In addition, please do not use the built-in regulator circuit other than the purpose of this IC operation.

When it is no use the built-in regulator, do not supply 3.3 V at 39 pin.

Regulator circuit		The Input terminal which regulator output
3.3 V Input terminal	2.5 V Output terminal	
REGVDD33A (39 pin)	REG25OUTA (42 pin)	ADVDD1 (43 pin) ADVDD2 (54 pin)

6. Absolute maximum rating

The absolute maximum ratings are rated values which must not be exceeded during operation, even for an instant. Exceeding the absolute maximum ratings may result in destruction, degradation or other damage to the IC and other components. When designing applications for this IC, be sure that none of the absolute maximum rating values will ever be exceeded.

Characteristics	Terminal No.	Symbol	Rating	Unit
Power voltage1 (1.5 V)	3, 16, 30	VDD1	-0.3 to VSS + 2.0	V
Power voltage2 (2.5 V)	43, 54	VDD2	-0.3 to VSS + 3.5	V
Power voltage3 (3.3 V)	14, 29, 35, 39	VDD3	-0.3 to VSS + 3.9	V
Input voltage (2.5 V)	48, 50, 57, 59	VIN2	-0.3 to VDD2 + 0.3	V
Input voltage (3.3 V)	1, 33	VIN3	-0.3 to VDD3 + 0.3	V
Input voltage (3.3 V system, 5 V withstand voltage)	2, 61, 62	VIN4 (Note.1)	-0.3 to VSS + 5.5	V
Potential difference between power pins (between 1.5 V system power pins)	-	Δ V _{VG1} (Note.2)	0.3	V
Potential difference between power pins (between 2.5 V system power pins)	-	Δ V _{VG2} (Note.2)	0.3	V
Potential difference between power pins (between 3.3 V system power pins)	-	Δ V _{VG3} (Note.2)	0.3	V
Power dissipation	-	PD (Note.3)	1739	mW
Storage temperature	-	T _{stg}	-40 to 125	°C

Note1: The withstand voltage for pins (SDA, SCL, RESET) is 5 V.

Note2: For each of 1.5 V and 2.5 V and 3.3 V, system power supply terminal is made into the same voltage. The maximum potential difference should not exceed rating for all power supply terminals then. In addition, potential difference between all VSS terminal must be under 0.01 V in this status.

Note3: If you intended to use a temperature higher than Ta = 25°C, reduce by 17.39 mW per one degree (°C) increase. The case of Ta = 85°C, power dissipation is 696 mW.

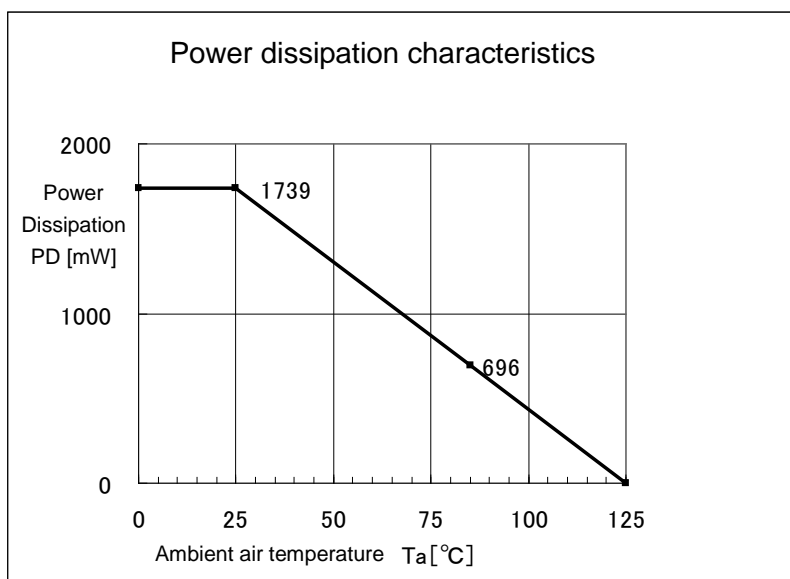

7. Operating Range

The TC90107FG is not guaranteed to function correctly if it is used outside its specified power voltage range (1.5 V system power: 1.40 V to 1.60 V, 2.5 V system power: 2.3 V to 2.7 V, 3.3 V system power: 3.0 V to 3.6 V). Please use within the specified operating conditions.

If you temporarily leave and then return to the specified operating conditions, this IC's conditions will change, and so it is necessary to reset the IC's power to continue using it correctly within the specified operating conditions.

Characteristics	Terminal No.	Symbol	Min	Typ.	Max	Unit
Power voltage of digital block	3, 16, 30	VDD-D	1.4	1.5	1.6	V
Power voltage of I/O block (*1)	14, 29	VDD-IO	3.0	3.3	3.6	V
Power voltage of regulator block (*1)	39	VDD-REG	3.0	3.3	3.6	V
Power voltage of XO block (*2)	35	VDD-XO	2.3	3.3	3.6	V
Power voltage of analog block	43, 54	VDD-AD	2.3	2.5	2.7	V
Operating temperature		T _{opr}	-40	-	85	°C

(*1) If possible, please set I/O power supply voltage and regulator power supply voltage into the potential.

(*2) When you connect XO power supply to 2.5 V power supply, if possible, please use the potential with analog power supply voltage.

Although connecting with 3.3 V power supply is also possible, please set I/O power supply voltage and regulator power supply voltage as the potential in that case.

8. Electrical characteristic

8.1 DC characteristic

(Ta = 25°C, VDD1 = 1.50 ± 0.1 V, VDD2 = 2.50 ± 0.2 V, VDD3 = 3.30 ± 0.3 V)

Charact erisitic	Terminal No..	Symbol	Min	Typ.	Max	Unit	Note
Power supply current (*4)	3, 16, 30	IDD1 (1.5 V)	-	-	75	mA	
	43, 54	IDD2 (2.5 V)	-	-	75	mA	When a built-in regulator was not used but 2.5 V power supply is supplied from the out side.
	14, 29, 35, 39	IDD3-1 (3.3 V)	-	-	30	mA	When a built-in regulator was not used but 2.5 V power supply is supplied from the out side.
		IDD3-2 (3.3 V)	-	-	105	mA	When a built-in regulator is used.
Input voltage	1, 33	VIH	VDD3 x 0.8	-	VDD3	V	I/O input terminal of 3.3 V system.
	2, 61, 62						I/O input terminal of 5.0 V system.
	1, 33	VIL	VSS	-	VDD3 x 0.2	V	I/O input terminal of 3.3 V system.
	2, 61, 62						I/O input terminal of 5.0 V system.
Input current	1, 33	IIH	-10	-	10	μA	I/O input terminal of 3.3 V system.
	2, 61, 62						I/O input terminal of 5.0 V system.
	1, 33	IIL	-10	-	10	μA	I/O input terminal of 3.3 V system.
	2, 61, 62						I/O input terminal of 5.0 V system.
Output voltage	7, 8, 9, 12, 17, 19, 20, 21, 23, 24, 26, 27, 34	VOH	VDD3 - 0.6	-	VDD3	V	I/O output terminal of 3.3 V system. When load current: -4 mA
		VOL	VSS	-	0.4	V	I/O output terminal of 3.3 V system. When load current: +4 mA

(*4) Power consumption (W) changes the calculation method by whether a built-in regulator is used or it is not used.

When a built-in regulator is used : Sum total of IDD1 and IDD3-2

When a built-in regulator is not used : Sum total of IDD1, IDD2, and IDD3-1

9. Package

LQFP64-P-1010-0.50E

Unit: mm

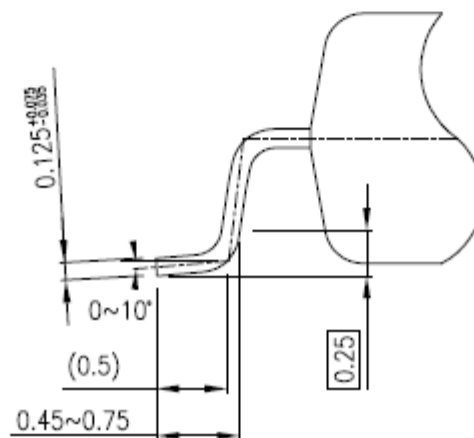
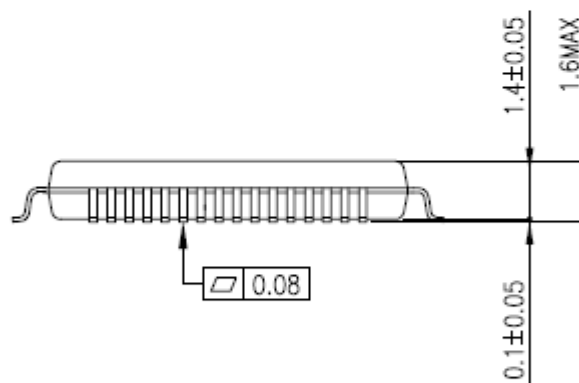
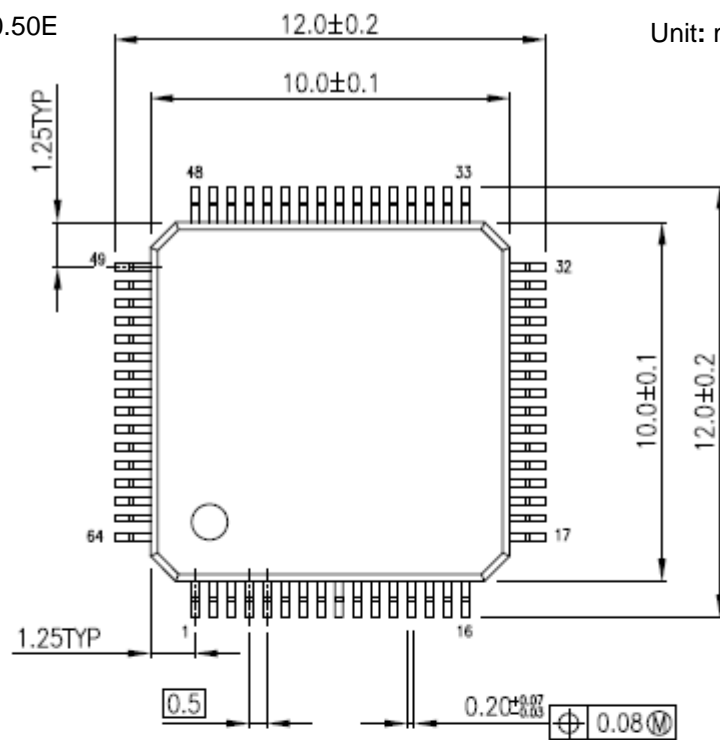

Weight: 0.40 g (Typ.)

RESTRICTIONS ON PRODUCT USE

- Toshiba Corporation, and its subsidiaries and affiliates (collectively "TOSHIBA"), reserve the right to make changes to the information in this document, and related hardware, software and systems (collectively "Product") without notice.
- This document and any information herein may not be reproduced without prior written permission from TOSHIBA. Even with TOSHIBA's written permission, reproduction is permissible only if reproduction is without alteration/omission.
- Though TOSHIBA works continually to improve Product's quality and reliability, Product can malfunction or fail. Customers are responsible for complying with safety standards and for providing adequate designs and safeguards for their hardware, software and systems which minimize risk and avoid situations in which a malfunction or failure of Product could cause loss of human life, bodily injury or damage to property, including data loss or corruption. Before customers use the Product, create designs including the Product, or incorporate the Product into their own applications, customers must also refer to and comply with (a) the latest versions of all relevant TOSHIBA information, including without limitation, this document, the specifications, the data sheets and application notes for Product and the precautions and conditions set forth in the "TOSHIBA Semiconductor Reliability Handbook" and (b) the instructions for the application with which the Product will be used with or for. Customers are solely responsible for all aspects of their own product design or applications, including but not limited to (a) determining the appropriateness of the use of this Product in such design or applications; (b) evaluating and determining the applicability of any information contained in this document, or in charts, diagrams, programs, algorithms, sample application circuits, or any other referenced documents; and (c) validating all operating parameters for such designs and applications. **TOSHIBA ASSUMES NO LIABILITY FOR CUSTOMERS' PRODUCT DESIGN OR APPLICATIONS.**
- **PRODUCT IS NEITHER INTENDED NOR WARRANTED FOR USE IN EQUIPMENTS OR SYSTEMS THAT REQUIRE EXTRAORDINARILY HIGH LEVELS OF QUALITY AND/OR RELIABILITY, AND/OR A MALFUNCTION OR FAILURE OF WHICH MAY CAUSE LOSS OF HUMAN LIFE, BODILY INJURY, SERIOUS PROPERTY DAMAGE AND/OR SERIOUS PUBLIC IMPACT ("UNINTENDED USE").** Except for specific applications as expressly stated in this document, Unintended Use includes, without limitation, equipment used in nuclear facilities, equipment used in the aerospace industry, Class 3 medical devices, equipment used for automobiles, and military vehicles and munitions. **IF YOU USE PRODUCT FOR UNINTENDED USE, TOSHIBA ASSUMES NO LIABILITY FOR PRODUCT.** For details, please contact your TOSHIBA sales representative or contact us via our website.
- Do not disassemble, analyze, reverse-engineer, alter, modify, translate or copy Product, whether in whole or in part.
- Product shall not be used for or incorporated into any products or systems whose manufacture, use, or sale is prohibited under any applicable laws or regulations.
- The information contained herein is presented only as guidance for Product use. No responsibility is assumed by TOSHIBA for any infringement of patents or any other intellectual property rights of third parties that may result from the use of Product. No license to any intellectual property right is granted by this document, whether express or implied, by estoppel or otherwise.
- **ABSENT A WRITTEN SIGNED AGREEMENT, EXCEPT AS PROVIDED IN THE RELEVANT TERMS AND CONDITIONS OF SALE FOR PRODUCT, AND TO THE MAXIMUM EXTENT ALLOWABLE BY LAW, TOSHIBA (1) ASSUMES NO LIABILITY WHATSOEVER, INCLUDING WITHOUT LIMITATION, INDIRECT, CONSEQUENTIAL, SPECIAL, OR INCIDENTAL DAMAGES OR LOSS, INCLUDING WITHOUT LIMITATION, LOSS OF PROFITS, LOSS OF OPPORTUNITIES, BUSINESS INTERRUPTION AND LOSS OF DATA, AND (2) DISCLAIMS ANY AND ALL EXPRESS OR IMPLIED WARRANTIES AND CONDITIONS RELATED TO SALE, USE OF PRODUCT, OR INFORMATION, INCLUDING WARRANTIES OR CONDITIONS OF MERCHANTABILITY, FITNESS FOR A PARTICULAR PURPOSE, ACCURACY OF INFORMATION, OR NONINFRINGEMENT.**
- Do not use or otherwise make available Product or related software or technology for any military purposes, including without limitation, for the design, development, use, stockpiling or manufacturing of nuclear, chemical, or biological weapons or missile technology products (mass destruction weapons). Product and related software and technology may be controlled under the applicable export laws and regulations including, without limitation, the Japanese Foreign Exchange and Foreign Trade Law and the U.S. Export Administration Regulations. Export and re-export of Product or related software or technology are strictly prohibited except in compliance with all applicable export laws and regulations.
- Please contact your TOSHIBA sales representative for details as to environmental matters such as the RoHS compatibility of Product. Please use Product in compliance with all applicable laws and regulations that regulate the inclusion or use of controlled substances, including without limitation, the EU RoHS Directive. **TOSHIBA ASSUMES NO LIABILITY FOR DAMAGES OR LOSSES OCCURRING AS A RESULT OF NONCOMPLIANCE WITH APPLICABLE LAWS AND REGULATIONS.**