

FIBER OPTIC TRANSMITTING MODULE

## TOTX1950A(F)

GENERAL PURPOSE OPTICAL TRANSMITTING MODULE

- For JIS F05 type optical connector
- CMOS level interface
- +5 V single power supply
- LED is driven by differential circuit.
- 650 nm LED

### 1. Absolute Maximum Ratings (Note) (Unless otherwise specified, Ta = 25°C)

Characteristics	Symbol	Rating	Unit
Storage Temperature	T <sub>stg</sub>	-40 to 95	°C
Operating Temperature	T <sub>opr</sub>	-40 to 85	°C
Supply Voltage	V <sub>CC</sub>	-0.5 to 6	V
Input Voltage	V <sub>IN</sub>	-0.5 to V <sub>CC</sub> +0.5	V
Soldering Temperature	T <sub>sol</sub>	260 (Note 1)	°C

Note: Using continuously heavy loads (e.g. the application of high temperature/current/voltage and the significant change in temperature, etc.) may cause this product to decrease in the reliability significantly even if the operating conditions (i.e. operating temperature/current/voltage, etc.) are within the absolute maximum ratings.

Please design the appropriate reliability upon reviewing the Toshiba Semiconductor Reliability Handbook ("Handling Precautions"/ "Derating Concept and Methods") and individual reliability data (i.e. reliability test report and estimated failure rate, etc.).

Note 1: Soldering time ≤ 10 s (More than 1 mm apart from the package).

### 2. Operating Ranges

Characteristics	Symbol	Min	Typ.	Max	Unit
Supply Voltage	V <sub>CC</sub>	4.75	5.0	5.25	V
High Level Input Voltage	V <sub>IH</sub>	3.5	-	V <sub>CC</sub>	V
Low Level Input Voltage	V <sub>IL</sub>	0	-	1.5	V

Start of commercial production  
2016-01

### 3. Electrical and Optical Characteristics (Ta = 25°C, Vcc = 5 V)

Characteristics	Symbol	Test Condition	Min	Typ.	Max	Unit
Data Rate	-	NRZ Code (Note 1)	DC	-	10	Mb/s
Transmission Distance	-	DC to 10 Mb/s, Using APF (Note 2)(Note 3)	0.2	-	50	m
		DC to 6 Mb/s, Using APF (Note 2)(Note 3)	0.2	-	50	m
		DC to 10 Mb/s, Using H-PCF (Note 2)(Note 4)	0.2	-	300	m
Pulse Width Distortion (Note 5)	$\Delta tw$	Pulse width 100 ns Pulse cycle 200 ns $C_L = 10$ pF	-30	-	30	ns
		Pulse width 165 ns Pulse cycle 330 ns $C_L = 10$ pF	-55	-	55	ns
Fiber Output Power (Note 6)	$P_f$	R = 5.6 k $\Omega$	-15	-	-9	dBm
Fiber Output Power (Note 7)	$P_f$	R = 3.3 k $\Omega$	-23	-	-18	dBm
Center Emission Wavelength	$\lambda_C$	-	-	650	-	nm
Current Consumption	$I_{CC}$	R = 5.6 k $\Omega$	-	12	30	mA
		R = 3.3 k $\Omega$	-	18	40	mA
High Level Input Voltage	$V_{IH}$	-	3.5	-	-	V
Low Level Input Voltage	$V_{IL}$	-	-	-	1.5	V
High Level Input Current	$I_{IH}$	$V_{CC} = 5.25$ V, $V_I = 2.7$ V	-	-	20	$\mu$ A
Low Level Input Current	$I_{IL}$	$V_{CC} = 5.25$ V, $V_I = 0.4$ V	-	-	-0.4	mA

Note 1: LED is on when input signal is high level, it is off when low level.  
The duty factor must be kept 25 to 75%.

Note 2: Optical Receiving Module TORX1950A(F)Usage.

Note 3: All Plastic Fiber(980 / 1000  $\mu$ m, cladding)with F05 type optical connector. Polished surface.

Note 4: Plastic Cladding Silica Fiber(200 $\mu$ m core / 230 $\mu$ m cladding)with F05 type optical connector.  
When using a polished or cut end face.

Note 5: Between input of TOTX1950A(F) and output of TORX1950A(F).

Note 6: Measure with a standard optical fiber with fiber optic connector(APF 1 m, polished surface). Valued by peak.

Note 7: Measure with a standard optical fiber with fiber optic connector(H-PCF 1 m, polished surface). Valued by peak.

## 4. Application Circuit

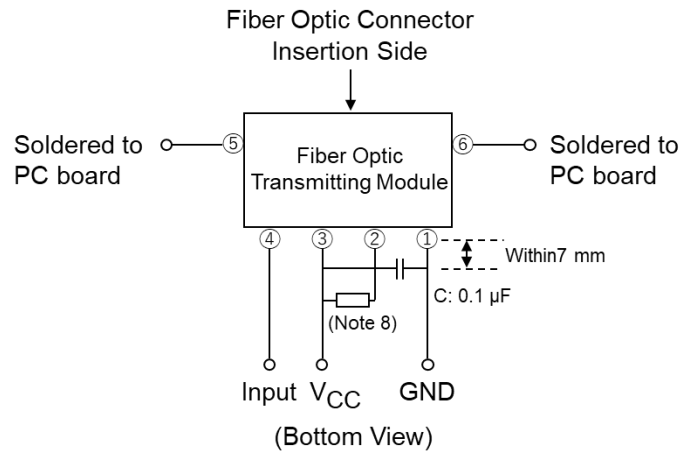

Note 8: Select a resistor value as follows.

### (1) DC to 10 Mb/s (with TORX1950A(F))

Fiber Optic Connector Type Name	Transmission Distance (m)	Resistor (kΩ)
F05 type Optical connector APF(980 / 1000 μm) with polished surface.	0.2 to 40	5.6
	10 to 50	3.3
F05 type Optical Connector with H-PCF(200 / 230 μm) non-Polished Surface. (cut by fiber cutter)	0.2 to 300	3.3

### (2) DC to 6 Mb/s (with TORX1950A(F))

Fiber Optic Connector Type Name	Transmission Distance (m)	Resistor (kΩ)
F05 type Optical connector APF(980 / 1000 μm) with polished surface.	0.2 to 50	5.6

## 5. Applicable Optical Fiber with Fiber Optic Connectors

All Plastic Fiber(980 / 1000 μm, cladding, NA = 0.5) with F05 type optical connector. Polished surface.  
 Plastic Cladding Silica Fiber(200 / 230 μm, cladding) with F05 type optical connector. Non-polished surface(cut by fiber cutter).

## 6. Precautions during use

### (1) Absolute maximum rating

The absolute maximum ratings are the limit values which must not be exceeded during operation of device. None of these rating value must not be exceeded. If the absolute maximum rating value is exceeded, the characteristics of devices may never be restored properly. In extreme cases, the device may be permanently damages.

### (2) Operating Range

The operating range is the range of conditions necessary for the device to operate as specified in individual technical datasheets and databooks. Care must be exercised in the design of the equipment.

If a device is used under conditions that do not exceed absolute maximum ratings but exceed the operating range, the specifications related to device operation and electrical characteristics may not be met, resulting in a decrease in reliability.

If greater reliability is required, derate the device's operating ranges for voltage, current, power and temperature before use.

### (3) Lifetime of light emitters

If an optical module is used for a long period of time, degeneration in the characteristics will mostly be due to a lowering of the fiber output power (Pf). This is caused by the degradation of the optical output of the LEDs used as the light source. The cause of degradation of the optical output of the LEDs may be defects in wafer crystallization or mold resin stress. The detailed causes are, however, not clear.

The lifetime of light emitters is greatly influenced by the operating conditions and the environment in which it is used as well as by the lifetime characteristics unique to the device type. Thus, when a light emitting device and its operating conditions determined, Toshiba recommend that lifetime characteristics be checked.

Depending on the environment conditions, Toshiba recommend that maintenance such as regular checks of the amount of optical output in accordance with the condition of operating environment.

### (4) Soldering

Optical modules are comprised of internal semiconductor devices. However, in principle, optical modules are optical components. During soldering, ensure that flux does not contact with the emitting surface or the detecting surface. Also ensure that proper flux removal is conducted after soldering.

Some optical modules come with a protective cap. The protective cap is used to avoid malfunction when the optical module is not in use. Note that it is not dust or waterproof.

As mentioned before, optical modules are optical components. Thus, in principle, soldering where there may be flux residue and flux removal after soldering is not recommended. Toshiba recommend that soldering be performed without the optical module mounted on the board. Then, after the board has been cleaned, the optical module should be soldered on to the board manually. If the optical module cannot be soldered manually, use non-halogen (chlorine-free) flux and make sure, without cleaning, there is no residue such as chlorine. This is one of the ways to eliminate the effects of flux. In such cases, be sure to check the devices' reliability.

### (5) Vibration and shock

This module is plastic sealed and has its wire fixed by resin. This structure is relatively resistant to vibration and shock. In actual equipment, there are sometimes cases in which vibration, shock, or stress is applied to soldered parts or connected parts, resulting in lines cut. A care must be taken in the design of equipment which will be subject to high levels of vibration.

### (6) Attaching the fiber optic transmitting module

Solder the fixed pin (pins 5 and 6) of the fiber optic transmitting module TOTX1950A(F) to the printed circuit board in order to fix it to the board.

### (7) Solvent

When using solvent for flux removal, do not use a high acid or high alkali solvent. Be careful not to pour solvent in to the optical connector ports. If solvent is inadvertently poured in to them, clean it off using cotton tips.

- (8) Protective cap  
When the TOTX1950A(F) is not in use, attach the protective cap.
- (9) Incidence of a photo Flash  
If strong light such as a photo flash is incident on an optical module, a transmission error may occur.  
Be careful to avoid such situations.
- (10) Supply voltage  
Use the supply voltage within the operating ranges ( $V_{CC} = 5 \pm 0.25 \text{ V}$ ). Make sure that supply voltage does not exceed the absolute maximum rating value of 6 V, even for an instant.
- (11) Input voltage  
If a voltage exceeding the absolute maximum rating value ( $V_{CC} + 0.5 \text{ V}$ ) is applied to the transmitters' input, the internal IC may suffer damage. If there is possibility that excessive voltage due to surges may be added to the input terminal, insert a protective circuit.
- (12) Soldering condition  
Solder at 260 °C or less for no more than ten seconds.
- (13) Precautions when disposing of devices and packing materials.  
When disposing devices and packing materials, follow the procedures stipulated by local regulations in order to protect the environment against contamination.

## 7. Package Outline drawing

Unit: mm

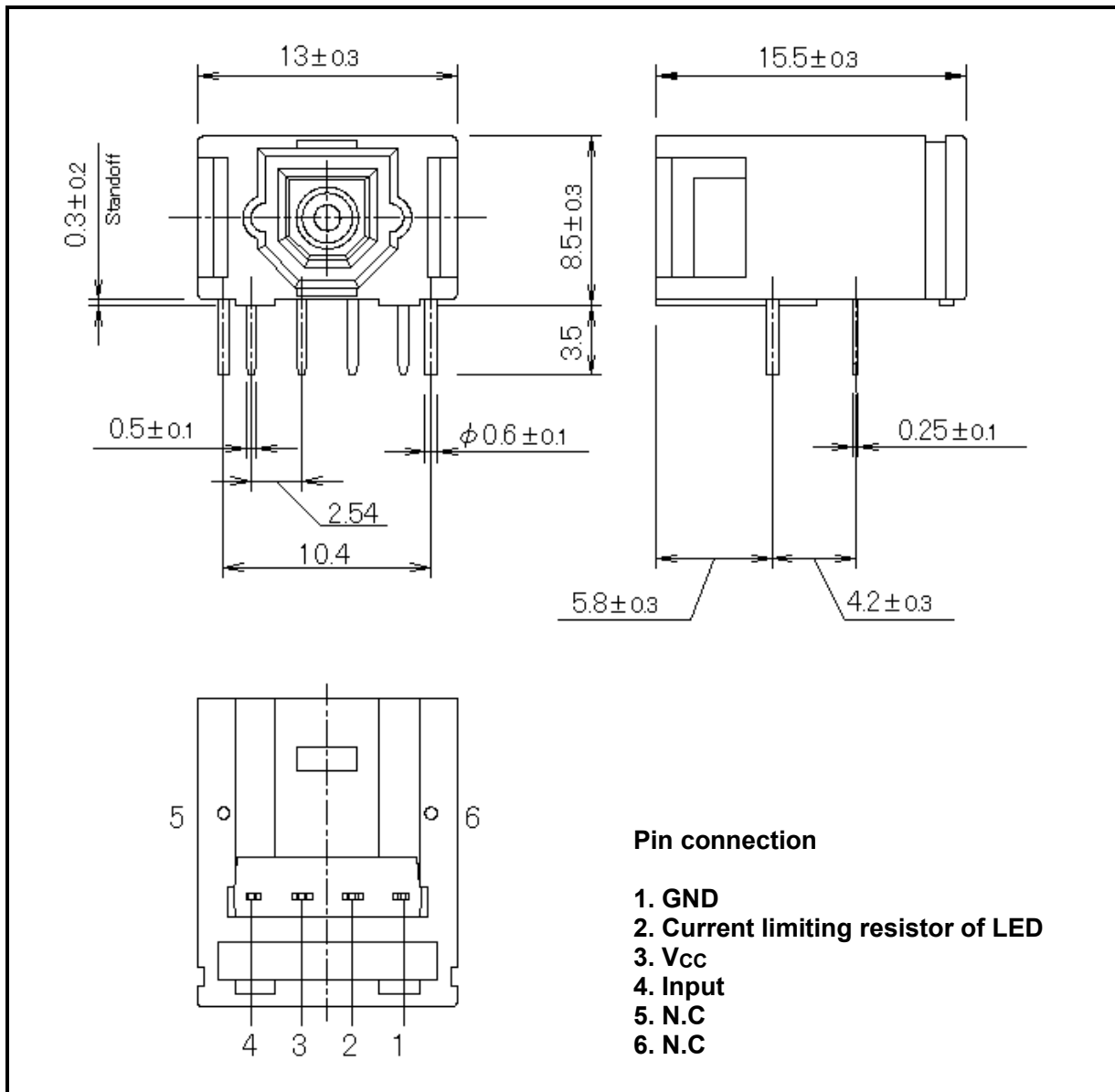

Weight: 2.3 g (typ.)

## RESTRICTIONS ON PRODUCT USE

Toshiba Corporation and its subsidiaries and affiliates are collectively referred to as "TOSHIBA". Hardware, software and systems described in this document are collectively referred to as "Product".

- TOSHIBA reserves the right to make changes to the information in this document and related Product without notice.
- This document and any information herein may not be reproduced without prior written permission from TOSHIBA. Even with TOSHIBA's written permission, reproduction is permissible only if reproduction is without alteration/omission.
- Though TOSHIBA works continually to improve Product's quality and reliability, Product can malfunction or fail. Customers are responsible for complying with safety standards and for providing adequate designs and safeguards for their hardware, software and systems which minimize risk and avoid situations in which a malfunction or failure of Product could cause loss of human life, bodily injury or damage to property, including data loss or corruption. Before customers use the Product, create designs including the Product, or incorporate the Product into their own applications, customers must also refer to and comply with (a) the latest versions of all relevant TOSHIBA information, including without limitation, this document, the specifications, the data sheets and application notes for Product and the precautions and conditions set forth in the "TOSHIBA Semiconductor Reliability Handbook" and (b) the instructions for the application with which the Product will be used with or for. Customers are solely responsible for all aspects of their own product design or applications, including but not limited to (a) determining the appropriateness of the use of this Product in such design or applications; (b) evaluating and determining the applicability of any information contained in this document, or in charts, diagrams, programs, algorithms, sample application circuits, or any other referenced documents; and (c) validating all operating parameters for such designs and applications. **TOSHIBA ASSUMES NO LIABILITY FOR CUSTOMERS' PRODUCT DESIGN OR APPLICATIONS.**
- **PRODUCT IS NEITHER INTENDED NOR WARRANTED FOR USE IN EQUIPMENTS OR SYSTEMS THAT REQUIRE EXTRAORDINARILY HIGH LEVELS OF QUALITY AND/OR RELIABILITY, AND/OR A MALFUNCTION OR FAILURE OF WHICH MAY CAUSE LOSS OF HUMAN LIFE, BODILY INJURY, SERIOUS PROPERTY DAMAGE AND/OR SERIOUS PUBLIC IMPACT ("UNINTENDED USE").** Except for specific applications as expressly stated in this document, Unintended Use includes, without limitation, equipment used in nuclear facilities, equipment used in the aerospace industry, Class 3 medical devices, equipment used for automobiles, and military vehicles and munitions. **IF YOU USE PRODUCT FOR UNINTENDED USE, TOSHIBA ASSUMES NO LIABILITY FOR PRODUCT.** For details, please contact your TOSHIBA sales representative or contact us via our website.
- Do not disassemble, analyze, reverse-engineer, alter, modify, translate or copy Product, whether in whole or in part.
- Product shall not be used for or incorporated into any products or systems whose manufacture, use, or sale is prohibited under any applicable laws or regulations.
- The information contained herein is presented only as guidance for Product use. No responsibility is assumed by TOSHIBA for any infringement of patents or any other intellectual property rights of third parties that may result from the use of Product. No license to any intellectual property right is granted by this document, whether express or implied, by estoppel or otherwise.
- **ABSENT A WRITTEN SIGNED AGREEMENT, EXCEPT AS PROVIDED IN THE RELEVANT TERMS AND CONDITIONS OF SALE FOR PRODUCT, AND TO THE MAXIMUM EXTENT ALLOWABLE BY LAW, TOSHIBA (1) ASSUMES NO LIABILITY WHATSOEVER, INCLUDING WITHOUT LIMITATION, INDIRECT, CONSEQUENTIAL, SPECIAL, OR INCIDENTAL DAMAGES OR LOSS, INCLUDING WITHOUT LIMITATION, LOSS OF PROFITS, LOSS OF OPPORTUNITIES, BUSINESS INTERRUPTION AND LOSS OF DATA, AND (2) DISCLAIMS ANY AND ALL EXPRESS OR IMPLIED WARRANTIES AND CONDITIONS RELATED TO SALE, USE OF PRODUCT, OR INFORMATION, INCLUDING WARRANTIES OR CONDITIONS OF MERCHANTABILITY, FITNESS FOR A PARTICULAR PURPOSE, ACCURACY OF INFORMATION, OR NONINFRINGEMENT.**
- GaAs (Gallium Arsenide) is used in Product. GaAs is harmful to humans if consumed or absorbed, whether in the form of dust or vapor. Handle with care and do not break, cut, crush, grind, dissolve chemically or otherwise expose GaAs in Product.
- Do not use or otherwise make available Product or related software or technology for any military purposes, including without limitation, for the design, development, use, stockpiling or manufacturing of nuclear, chemical, or biological weapons or missile technology products (mass destruction weapons). Product and related software and technology may be controlled under the applicable export laws and regulations including, without limitation, the Japanese Foreign Exchange and Foreign Trade Law and the U.S. Export Administration Regulations. Export and re-export of Product or related software or technology are strictly prohibited except in compliance with all applicable export laws and regulations.
- Please contact your TOSHIBA sales representative for details as to environmental matters such as the RoHS compatibility of Product. Please use Product in compliance with all applicable laws and regulations that regulate the inclusion or use of controlled substances, including without limitation, the EU RoHS Directive. **TOSHIBA ASSUMES NO LIABILITY FOR DAMAGES OR LOSSES OCCURRING AS A RESULT OF NONCOMPLIANCE WITH APPLICABLE LAWS AND REGULATIONS.**