

CMOS Digital Integrated Circuits Silicon Monolithic

74HC4051D,74HC4052D

1. Functional Description

74HC4051D:8-Channel Analog Multiplexer/Demultiplexer

74HC4052D:Dual 4-Channel Analog Multiplexer/Demultiplexer

2. General

The 74HC4051D, 74HC4052D are high speed CMOS ANALOG MULTIPLEXER/DEMUTIPLEXER fabricated with silicon gate C²MOS technology. They achieve the high speed operation similar to equivalent LSTTL while maintaining the CMOS low power dissipation.

The 74HC4051D has an 8 channel configuration and the 74HC4052D has a 4 channel × 2 configuration.

The digital signal to the control terminal turns "ON" the corresponding switch of each channel a large amplitude signal ($V_{CC} - V_{EE}$) can then be switched by the small logical amplitude ($V_{CC} - GND$) control signal.

For example, in the case of $V_{CC} = 5\text{ V}$, $GND = 0\text{ V}$, $V_{EE} = -5\text{ V}$, signals between -5 V and $+5\text{ V}$ can be switched from the logical circuit with a single power supply of 5 V . As the ON-resistance of each switch is low, they can be connected to circuits with low input impedance.

All inputs are equipped with protection circuits against static discharge or transient excess voltage.

3. Features

- (1) Wide operating temperature range: $T_{opr} = -40$ to $125\text{ }^{\circ}\text{C}$ (Note 1)
- (2) Low power dissipation: $I_{CC} = 4.0\text{ }\mu\text{A}$ (max) ($V_{CC} = 6.0\text{ V}$, $V_{EE} = GND$, $T_a = 25\text{ }^{\circ}\text{C}$)
- (3) Low ON-resistance: $R_{ON} = 50\text{ }\Omega$ (typ.) at $V_{CC} - V_{EE} = 9\text{ V}$
- (4) High degree of linearity: $THD = 0.02\text{ }\%$ (typ.) at $V_{CC} - V_{EE} = 9\text{ V}$

Note 1: Operating Range spec of $T_{opr} = -40\text{ }^{\circ}\text{C}$ to $125\text{ }^{\circ}\text{C}$ is applicable only for the products which manufactured after July 2020.

4. Packaging

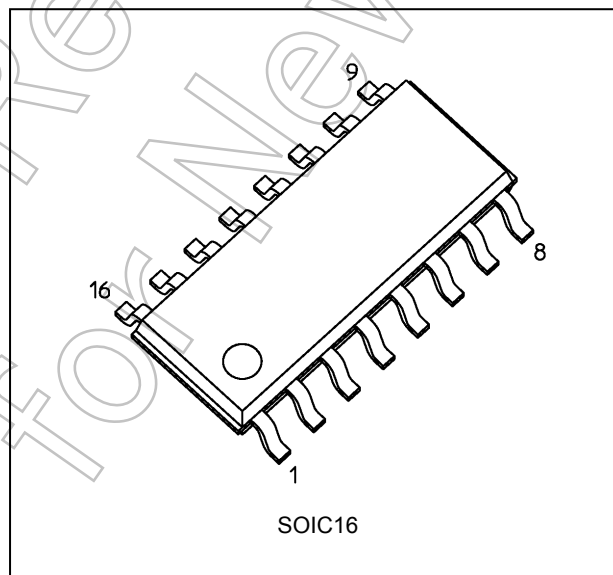

Start of commercial production

2016-04

5. Pin Assignment

74HC4051D

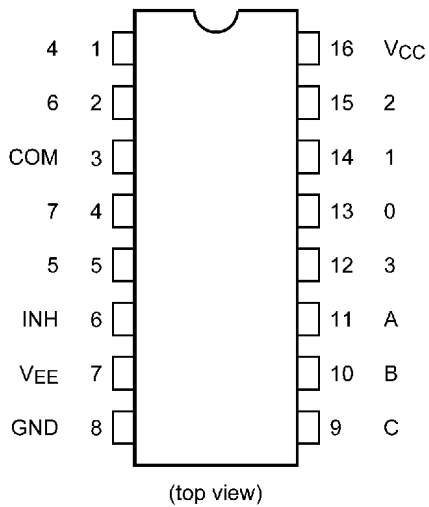

74HC4052D

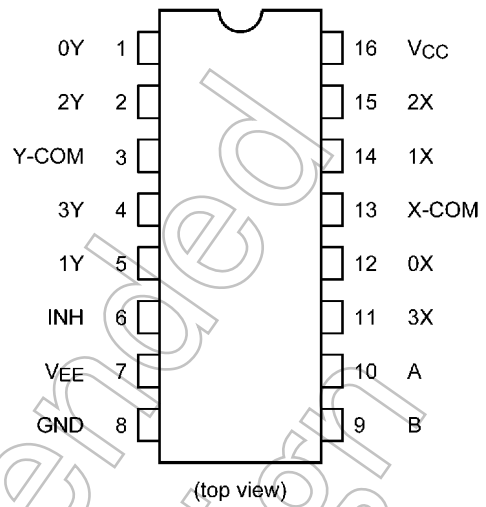

6. IEC Logic Symbol

74HC4051D

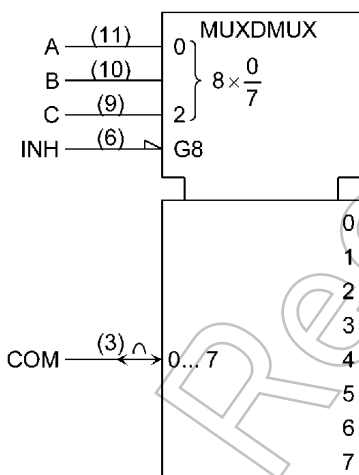

74HC4052D

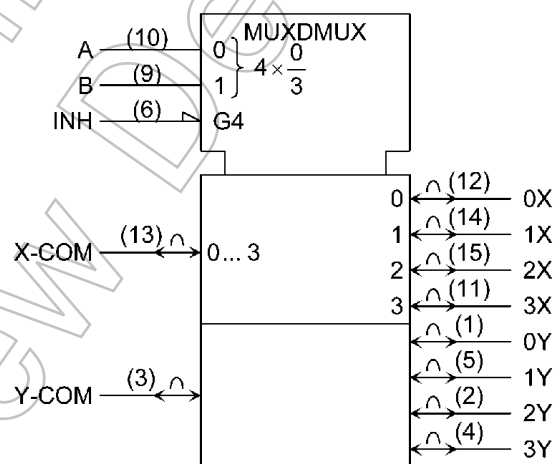

7. Marking

74HC4051D

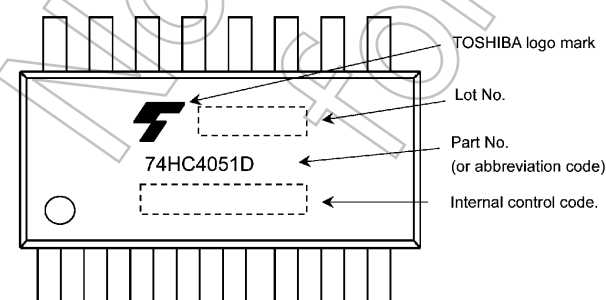

74HC4052D

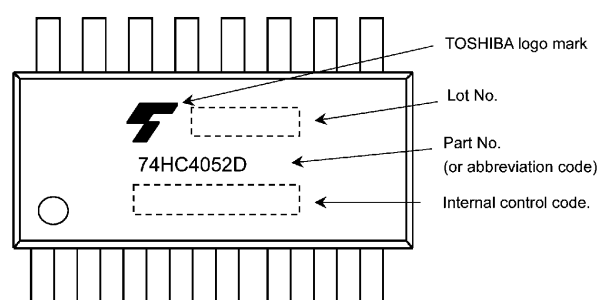

8. System Diagram

74HC4051D

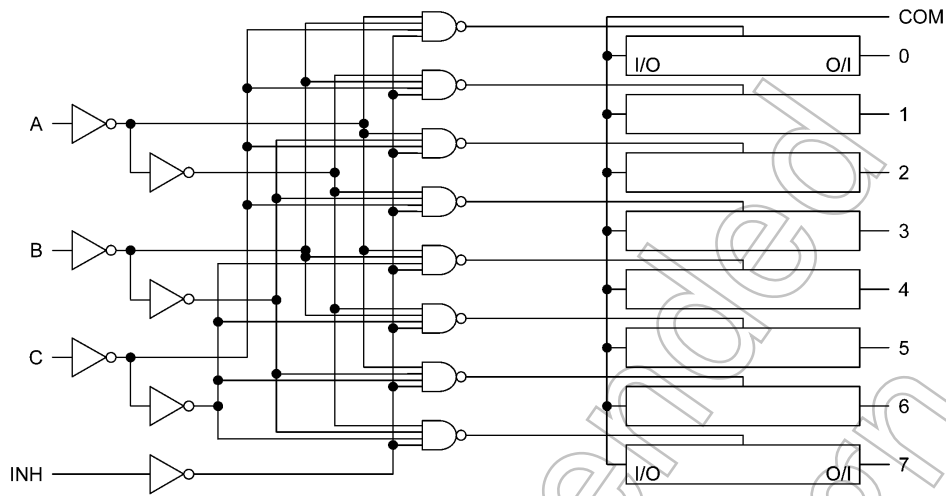

74HC4052D

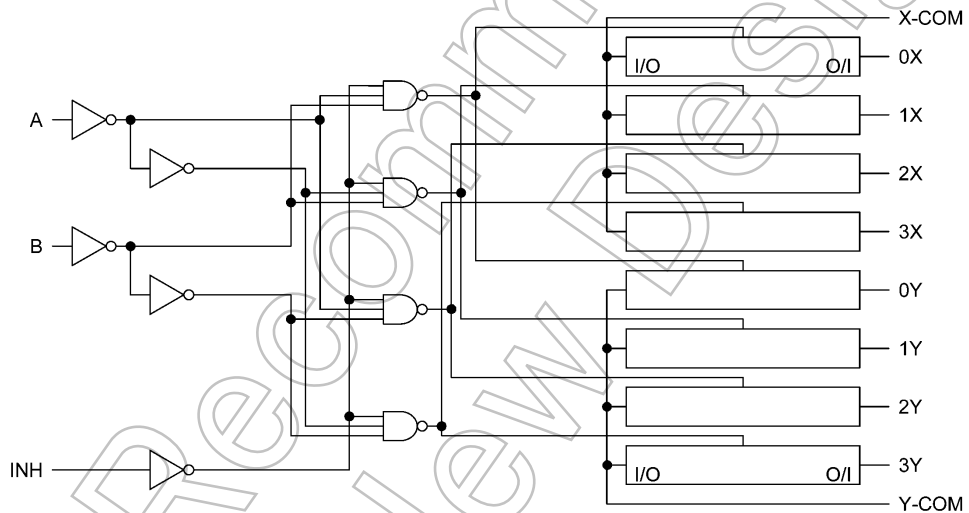

9. Truth Table

Input Inhibit	Input C*	Input B	Input A	ON Channel 74HC4051D	ON Channel 74HC4052D
L	L	L	L	0	0X, 0Y
L	L	L	H	1	1X, 1Y
L	L	H	L	2	2X, 2Y
L	L	H	H	3	3X, 3Y
L	H	L	L	4	—
L	H	L	H	5	—
L	H	H	L	6	—
L	H	H	H	7	—
H	X	X	X	None	None

X: Don't care

*: Except 74HC4052D

10. Absolute Maximum Ratings (Note)

Characteristics	Symbol	Note	Rating	Unit
Supply voltage	V_{CC}		-0.5 to 7.0	V
Supply voltage	V_{EE}		-7.0 to 0	V
Supply voltage	$V_{CC}-V_{EE}$		-0.5 to 13.0	V
Input voltage	V_{IN}		-0.5 to $V_{CC} + 0.5$	V
Switch I/O voltage	$V_{I/O}$		$V_{EE} - 0.5$ to $V_{CC} + 0.5$	V
Input diode current	I_{IK}		± 20	mA
I/O diode current	$I_{I/OK}$		± 20	mA
Switch through current	I_T		± 25	mA
V_{CC} /ground current	I_{CC}		± 50	mA
Power dissipation	P_D	(Note 1)	500	mW
Storage temperature	T_{stg}		-65 to 150	°C

Note: Exceeding any of the absolute maximum ratings, even briefly, lead to deterioration in IC performance or even destruction.

Using continuously under heavy loads (e.g. the application of high temperature/current/voltage and the significant change in temperature, etc.) may cause this product to decrease in the reliability significantly even if the operating conditions (i.e. operating temperature/current/voltage, etc.) are within the absolute maximum ratings and the operating ranges.

Please design the appropriate reliability upon reviewing the Toshiba Semiconductor Reliability Handbook ("Handling Precautions"/"Derating Concept and Methods") and individual reliability data (i.e. reliability test report and estimated failure rate, etc.).

Note 1: P_D derates linearly with -8 mW/°C above 85 °C.

11. Operating Ranges (Note)

Characteristics	Symbol	Note	Rating	Unit
Supply voltage	V_{CC}		2.0 to 6.0	V
Supply voltage	V_{EE}		-6.0 to 0	V
Supply voltage	$V_{CC}-V_{EE}$		2.0 to 12.0	V
Input voltage	V_{IN}		0 to V_{CC}	V
Switch I/O voltage	$V_{I/O}$		V_{EE} to V_{CC}	V
Operating temperature	T_{opr}	(Note 1)	-40 to 125	°C
Input rise and fall times	t_r, t_f		0 to 50	μs

Note: The operating ranges must be maintained to ensure the normal operation of the device.

Unused inputs must be tied to either V_{CC} or GND.

Note 1: Operating Range spec of $T_{opr} = -40$ °C to 125 °C is applicable only for the products which manufactured after July 2020.

12. Electrical Characteristics

12.1. DC Characteristics (Unless otherwise specified, $T_a = 25\text{ }^\circ\text{C}$)

Characteristics	Symbol	Test Condition	V_{EE} (V)	V_{CC} (V)	Min	Typ.	Max	Unit				
High-level input voltage	V_{IH}	—		2.0	1.50	—	—	V				
				4.5	3.15	—	—					
				6.0	4.20	—	—					
Low-level input voltage	V_{IL}	—		2.0	—	—	0.50	V				
				4.5	—	—	1.35					
				6.0	—	—	1.80					
ON-resistance	R_{ON}	$V_{IN} = V_{IH}$ or V_{IL} $V_{IO} = V_{CC}$ to V_{EE} $I_{IO} \leq 2\text{ mA}$	GND	4.5	—	180	240	Ω				
				-4.5	4.5	—	140		190			
				-6.0	6.0	—	135		180			
			$V_{IN} = V_{IH}$ or V_{IL} $V_{IO} = V_{EE}$ $I_{IO} \leq 2\text{ mA}$	GND	2.0	—	210		—			
					4.5	—	150		200			
					-4.5	4.5	—		130	170		
		$V_{IN} = V_{IH}$ or V_{IL} $V_{IO} = V_{CC}$ $I_{IO} \leq 2\text{ mA}$	GND	2.0	—	220	—					
				4.5	—	95	130					
				-4.5	4.5	—	75		100			
		Difference of ON-resistance between switches	ΔR_{ON}	$V_{IN} = V_{IH}$ or V_{IL} $V_{IO} = V_{CC}$ to V_{EE} $I_{IO} \leq 2\text{ mA}$	GND	4.5	—		10	30	Ω	
						-4.5	4.5		—	5		12
						-6.0	6.0		—	5		10
Input/Output leakage current (Switch OFF)	I_{OFF}	$V_{OS} = V_{CC}$ or GND $V_{IS} = \text{GND}$ or V_{CC} $V_{IN} = V_{IH}$ or V_{IL}	GND	6.0	—	—	± 0.06	μA				
				-6.0	6.0	—	± 0.1					
Input/Output leakage current (Switch ON)	I_{IO}	$V_{OS} = V_{CC}$ or GND $V_{IN} = V_{IH}$ or V_{IL}	GND	6.0	—	—	± 0.06	μA				
				-6.0	6.0	—	± 0.1					
Control input leakage current	I_{IN}	$V_{IN} = V_{CC}$ or GND	GND	6.0	—	—	± 0.1	μA				
Quiescent supply current	I_{CC}	$V_{IN} = V_{CC}$ or GND	GND	6.0	—	—	4.0	μA				
				-6.0	6.0	—	8.0					

Not for New

12.2. DC Characteristics (Unless otherwise specified, $T_a = -40$ to 85 °C)

Characteristics	Symbol	Test Condition	V_{EE} (V)	V_{CC} (V)	Min	Max	Unit
High-level input voltage	V_{IH}	—		2.0	1.50	—	V
				4.5	3.15	—	
				6.0	4.20	—	
Low-level input voltage	V_{IL}	—		2.0	—	0.50	V
				4.5	—	1.35	
				6.0	—	1.80	
ON-resistance	R_{ON}	$V_{IN} = V_{IH}$ or V_{IL} $V_{I/O} = V_{CC}$ to V_{EE} $I_{I/O} \leq 2$ mA	GND	4.5	—	300	Ω
			-4.5	4.5	—	240	
			-6.0	6.0	—	225	
		$V_{IN} = V_{IH}$ or V_{IL} $V_{I/O} = V_{EE}$ $I_{I/O} \leq 2$ mA	GND	4.5	—	250	
			-4.5	4.5	—	215	
			-6.0	6.0	—	215	
		$V_{IN} = V_{IH}$ or V_{IL} $V_{I/O} = V_{CC}$ $I_{I/O} \leq 2$ mA	GND	4.5	—	165	
			-4.5	4.5	—	125	
			-6.0	6.0	—	125	
Difference of ON-resistance between switches	ΔR_{ON}	$V_{IN} = V_{IH}$ or V_{IL} $V_{I/O} = V_{CC}$ to V_{EE} $I_{I/O} \leq 2$ mA	GND	4.5	—	35	Ω
			-4.5	4.5	—	15	
			-6.0	6.0	—	12	
Input/Output leakage current (Switch OFF)	I_{OFF}	$V_{OS} = V_{CC}$ or GND $V_{IS} = GND$ or V_{CC} $V_{IN} = V_{IH}$ or V_{IL}	GND	6.0	—	± 0.6	μA
			-6.0	6.0	—	± 1.0	
Input/Output leakage current (Switch ON)	$I_{I/O}$	$V_{OS} = V_{CC}$ or GND $V_{IN} = V_{IH}$ or V_{IL}	GND	6.0	—	± 0.6	μA
			-6.0	6.0	—	± 1.0	μA
Control input leakage current	I_{IN}	$V_{IN} = V_{CC}$ or GND	GND	6.0	—	± 1.0	μA
Quiescent supply current	I_{CC}	$V_{IN} = V_{CC}$ or GND	GND	6.0	—	40.0	μA
			-6.0	6.0	—	80.0	

Not Recommended for New Design

12.3. DC Characteristics (Note) (Unless otherwise specified, $T_a = -40$ to 125 °C)

Characteristics	Symbol	Test Condition	V_{EE} (V)	V_{CC} (V)	Min	Max	Unit
High-level input voltage	V_{IH}	—		2.0	1.50	—	V
				4.5	3.15	—	
				6.0	4.20	—	
Low-level input voltage	V_{IL}	—		2.0	—	0.50	V
				4.5	—	1.35	
				6.0	—	1.80	
ON-resistance	R_{ON}	$V_{IN} = V_{IH}$ or V_{IL} $V_{I/O} = V_{CC}$ to V_{EE} $I_{I/O} \leq 2$ mA	GND	4.5	—	340	Ω
			-4.5	4.5	—	275	
			-6.0	6.0	—	255	
		$V_{IN} = V_{IH}$ or V_{IL} $V_{I/O} = V_{EE}$ $I_{I/O} \leq 2$ mA	GND	4.5	—	285	
			-4.5	4.5	—	245	
			-6.0	6.0	—	245	
		$V_{IN} = V_{IH}$ or V_{IL} $V_{I/O} = V_{CC}$ $I_{I/O} \leq 2$ mA	GND	4.5	—	190	
			-4.5	4.5	—	145	
			-6.0	6.0	—	145	
Difference of ON-resistance between switches	ΔR_{ON}	$V_{IN} = V_{IH}$ or V_{IL} $V_{I/O} = V_{CC}$ to V_{EE} $I_{I/O} \leq 2$ mA	GND	4.5	—	35	Ω
			-4.5	4.5	—	15	
			-6.0	6.0	—	12	
Input/Output leakage current (Switch OFF)	I_{OFF}	$V_{OS} = V_{CC}$ or GND $V_{IS} = GND$ or V_{CC} $V_{IN} = V_{IL}$	GND	6.0	—	± 3.0	μA
			-6.0	6.0	—	± 5.0	
Input/Output leakage current (Switch ON)	$I_{I/O}$	$V_{OS} = V_{CC}$ or GND $V_{IN} = V_{IH}$ or V_{IL}	GND	6.0	—	± 3.0	μA
			-6.0	6.0	—	± 5.0	
Control input leakage current	I_{IN}	$V_{IN} = V_{CC}$ or GND	GND	6.0	—	± 1.0	μA
Quiescent supply current	I_{CC}	$V_{IN} = V_{CC}$ or GND	GND	6.0	—	80.0	μA
			-6.0	6.0	—	160.0	

Note: Operating Range spec of $T_{opr} = -40$ °C to 125 °C is applicable only for the products which manufactured after July 2020.

Not for New

12.4. AC Characteristics

(Unless otherwise specified, $C_L = 50 \text{ pF}$, $T_a = 25 \text{ }^\circ\text{C}$, Input: $t_r = t_f = 6 \text{ ns}$)

Characteristics	Part Number	Symbol	Test Condition	V_{EE} (V)	V_{CC} (V)	Min	Typ.	Max	Unit	
Phase difference between input to output		$\varphi_{I/O}$	—	GND	2.0	—	18	25	ns	
				GND	4.5	—	7	12		
				GND	6.0	—	6	10		
				-4.5	4.5	—	5	8		
Output enable time	74HC4051D	t_{PZL}, t_{PZH}	$R_L = 1 \text{ k}\Omega$ Figure 1	GND	2.0	—	90	145	ns	
				GND	4.5	—	30	45		
				GND	6.0	—	25	35		
				-4.5	4.5	—	24	34		
	74HC4052D			GND	2.0	—	90	145		ns
				GND	4.5	—	30	45		
				GND	6.0	—	25	35		
				-4.5	4.5	—	24	34		
Output disable time	74HC4051D	t_{PLZ}, t_{PHZ}	$R_L = 1 \text{ k}\Omega$ Figure 1	GND	2.0	—	56	85	ns	
				GND	4.5	—	26	35		
				GND	6.0	—	25	33		
				-4.5	4.5	—	24	32		
	74HC4052D			GND	2.0	—	56	85		ns
				GND	4.5	—	26	35		
				GND	6.0	—	25	33		
				-4.5	4.5	—	24	32		
Control input capacitance		C_{IN}				5	10	pF		
Common terminal capacitance	74HC4051D	C_{IS}	Figure 2	-5.0	5.0	—	36	70	pF	
	74HC4052D						19	40		
Switch terminal capacitance	74HC4051D	C_{OS}	Figure 2	-5.0	5.0	—	7	15	pF	
	74HC4052D						7	15		
Feedthrough capacitance	74HC4051D	C_{IOS}	Figure 2	-5.0	5.0	—	0.95	2	pF	
	74HC4052D						0.85	2		
Power dissipation capacitance	74HC4051D	C_{PD}	Figure 2 (Note 1)	-5.0	5.0	—	11	—	pF	
	74HC4052D						19	—		

Note 1: C_{PD} is defined as the value of the internal equivalent capacitance which is calculated from the operating current consumption without load. Average operating current can be obtained by the equation.

$$I_{CC(opr)} = C_{PD} \times V_{CC} \times f_{IN} + I_{CC}$$

12.5. AC Characteristics (Unless otherwise specified, $C_L = 50 \text{ pF}$, $T_a = -40 \text{ to } 85 \text{ }^\circ\text{C}$, Input: $t_r = t_f = 6 \text{ ns}$)

Characteristics	Part Number	Symbol	Test Condition	V_{EE} (V)	V_{CC} (V)	Min	Max	Unit
Phase difference between input to output		$\varphi_{I/O}$	—	GND	2.0	—	30	ns
				GND	4.5	—	15	
				GND	6.0	—	13	
				-4.5	4.5	—	10	
Output enable time	74HC4051D	t_{PZL}, t_{PZH}	$R_L = 1 \text{ k}\Omega$ Figure 1	GND	2.0	—	150	ns
				GND	4.5	—	55	
				GND	6.0	—	42	
				-4.5	4.5	—	41	
	74HC4052D		$R_L = 1 \text{ k}\Omega$ Figure 1	GND	2.0	—	150	
				GND	4.5	—	55	
				GND	6.0	—	42	
				-4.5	4.5	—	41	
Output disable time	74HC4051D	t_{PLZ}, t_{PHZ}	$R_L = 1 \text{ k}\Omega$ Figure 1	GND	2.0	—	90	ns
				GND	4.5	—	45	
				GND	6.0	—	40	
				-4.5	4.5	—	39	
	74HC4052D		$R_L = 1 \text{ k}\Omega$ Figure 1	GND	2.0	—	90	
				GND	4.5	—	45	
				GND	6.0	—	40	
				-4.5	4.5	—	39	
Control input capacitance		C_{IN}	—	—	—	10	pF	
Common terminal capacitance	74HC4051D	C_{IS}	Figure 2	-5.0	5.0	—	70	pF
	74HC4052D					—	40	
Switch terminal capacitance	74HC4051D	C_{OS}	Figure 2	-5.0	5.0	—	15	pF
	74HC4052D					—	15	
Feedthrough capacitance	74HC4051D	C_{IOS}	Figure 2	-5.0	5.0	—	2	pF
	74HC4052D					—	2	

Not for New

12.6. AC Characteristics (Note)

(Unless otherwise specified, $C_L = 50 \text{ pF}$, $T_a = -40 \text{ to } 125 \text{ }^\circ\text{C}$, Input: $t_r = t_f = 6 \text{ ns}$)

Characteristics	Part Number	Symbol	Test Condition	V_{EE} (V)	V_{CC} (V)	Min	Max	Unit	
Phase difference between input to output		$\varphi_{I/O}$	—	GND	2.0	—	35	ns	
				GND	4.5	—	17		
				GND	6.0	—	15		
				-4.5	4.5	—	12		
Output enable time	74HC4051D	t_{PZL}, t_{PZH}	$R_L = 1 \text{ k}\Omega$ Figure 1	GND	2.0	—	155	ns	
				GND	4.5	—	62		
				GND	6.0	—	47		
				-4.5	4.5	—	46		
	74HC4052D			GND	2.0	—	155		ns
				GND	4.5	—	62		
				GND	6.0	—	47		
				-4.5	4.5	—	46		
Output disable time	74HC4051D	t_{PLZ}, t_{PHZ}	$R_L = 1 \text{ k}\Omega$ Figure 1	GND	2.0	—	95	ns	
				GND	4.5	—	52		
				GND	6.0	—	45		
				-4.5	4.5	—	44		
	74HC4052D			GND	2.0	—	95		ns
				GND	4.5	—	52		
				GND	6.0	—	45		
				-4.5	4.5	—	44		
Control input capacitance		C_{IN}	—	—	—	10	pF		
Common terminal capacitance	74HC4051D	C_{IS}	Figure 2	-5.0	5.0	—	70	pF	
	74HC4052D			-5.0	5.0	—	40		
Switch terminal capacitance	74HC4051D	C_{OS}	Figure 2	-5.0	5.0	—	15	pF	
	74HC4052D			C_{OS}	-5.0	5.0	—		15
Feedthrough capacitance	74HC4051D	C_{IOS}	Figure 2	-5.0	5.0	—	2	pF	
	74HC4052D			-5.0	5.0	—	2		

Note: Operating Range spec of $T_{opr} = -40 \text{ }^\circ\text{C}$ to $125 \text{ }^\circ\text{C}$ is applicable only for the products which manufactured after July 2020.

Not for New

12.7. Analog Switch Characteristics ($T_a = 25\text{ }^\circ\text{C}$) (Note)

Characteristics	Part Number	Symbol	Test Condition	V_{EE} (V)	V_{CC} (V)	Typ.	Unit	
Sine Wave Distortion		THD	$R_L = 10\text{ k}\Omega$, $C_L = 50\text{ pF}$ $f_{IN} = 1\text{ kHz}$	$V_{IN} = 4.0\text{ V}_{p-p}$	-2.25	2.25	0.025	%
				$V_{IN} = 8.0\text{ V}_{p-p}$	-4.5	4.5	0.020	
				$V_{IN} = 11.0\text{ V}_{p-p}$	-6.0	6.0	0.018	
Maximum frequency response		$f_{MAX(I/O)}$	Adjust f_{IN} voltage to obtain 0 dBm at V_{OS} . Increase f_{IN} frequency until dB meter reads -3 dB. $R_L = 50\text{ }\Omega$, $C_L = 10\text{ pF}$ $f_{IN} = 1\text{ MHz}$, sine wave Figure 3	(Note 1)	-2.25	2.25	120	MHz
	(Note 2)					45		
						70		
	(Note 1)			-4.5	4.5	190		
	(Note 2)					70		
						110		
	(Note 1)			-6.0	6.0	200		
	(Note 2)					85		
			140					
Feed through attenuation (switch OFF)		FTH	V_{IN} is centered at $(V_{CC}/2)$. Adjust input for 0 dBm. $R_L = 600\text{ }\Omega$, $C_L = 50\text{ pF}$, $f_{IN} = 1\text{ MHz}$, sine wave Figure 4	-2.25	2.25	-50	dB	
				-4.5	4.5	-50		
				-6.0	6.0	-50		
Crosstalk (control input to signal output)		X_{talk}	$R_L = 600\text{ }\Omega$, $C_L = 50\text{ pF}$, $f_{IN} = 1\text{ MHz}$, square wave ($t_r = t_f = 6\text{ ns}$) Figure 5	-2.25	2.25	60	mV	
				-4.5	4.5	140		
				-6.0	6.0	200		
Crosstalk (between any switches)		X_{talk}	Adjust V_{IN} to obtain 0 dBm at input. $R_L = 600\text{ }\Omega$, $C_L = 50\text{ pF}$, $f_{IN} = 1\text{ MHz}$, sine wave Figure 6	-2.25	2.25	-50	dB	
				-4.5	4.5	-50		
				-6.0	6.0	-50		

Note: These characteristics are determined by design of devices.

Note 1: Input COMMON terminal, and measured at SWITCH terminal.

Note 2: Input SWITCH terminal, and measured at COMMON terminal.

Not Ready for New

13. AC Test Circuit

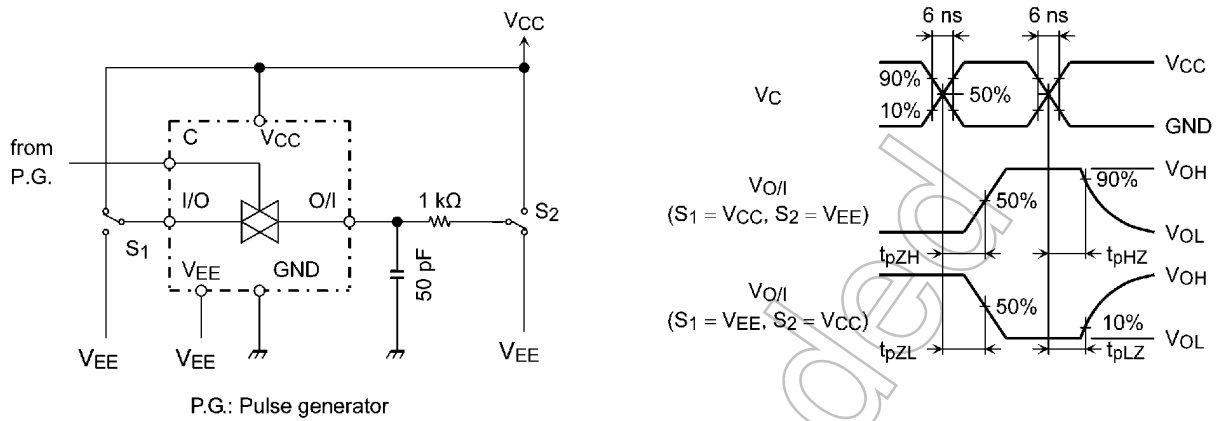

Figure 1 t_{pLZ} , t_{pHZ} , t_{pZL} , t_{pZH}

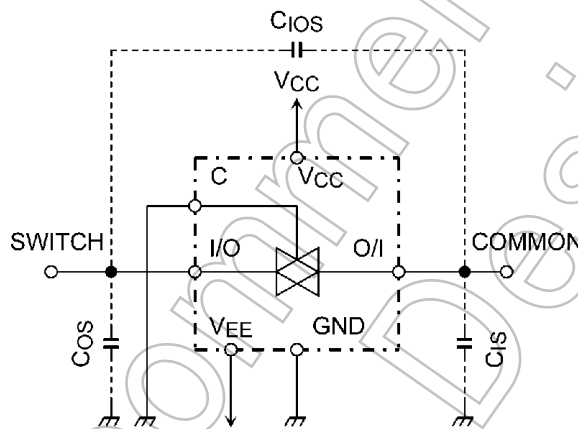

Figure 2 C_{ios} , C_{is} , C_{os}

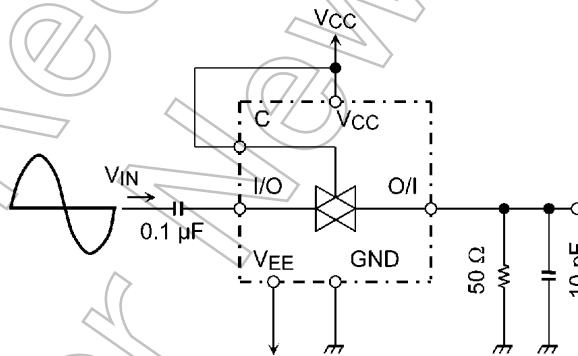

Figure 3 Frequency Response

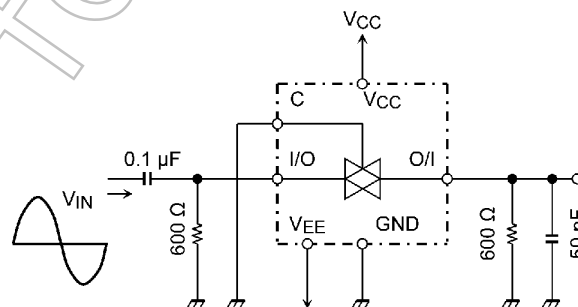

Figure 4 Feedthrough Attenuation

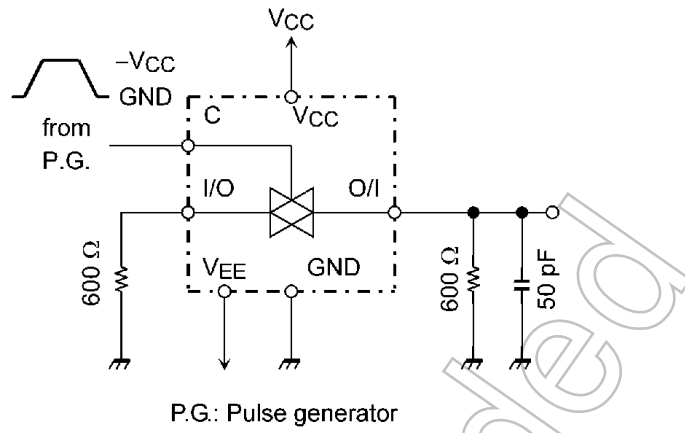

Figure 5 Cross Talk (control input to output signal)

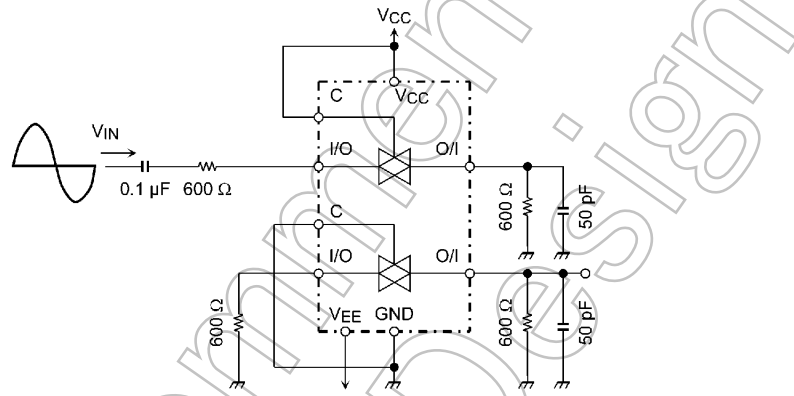
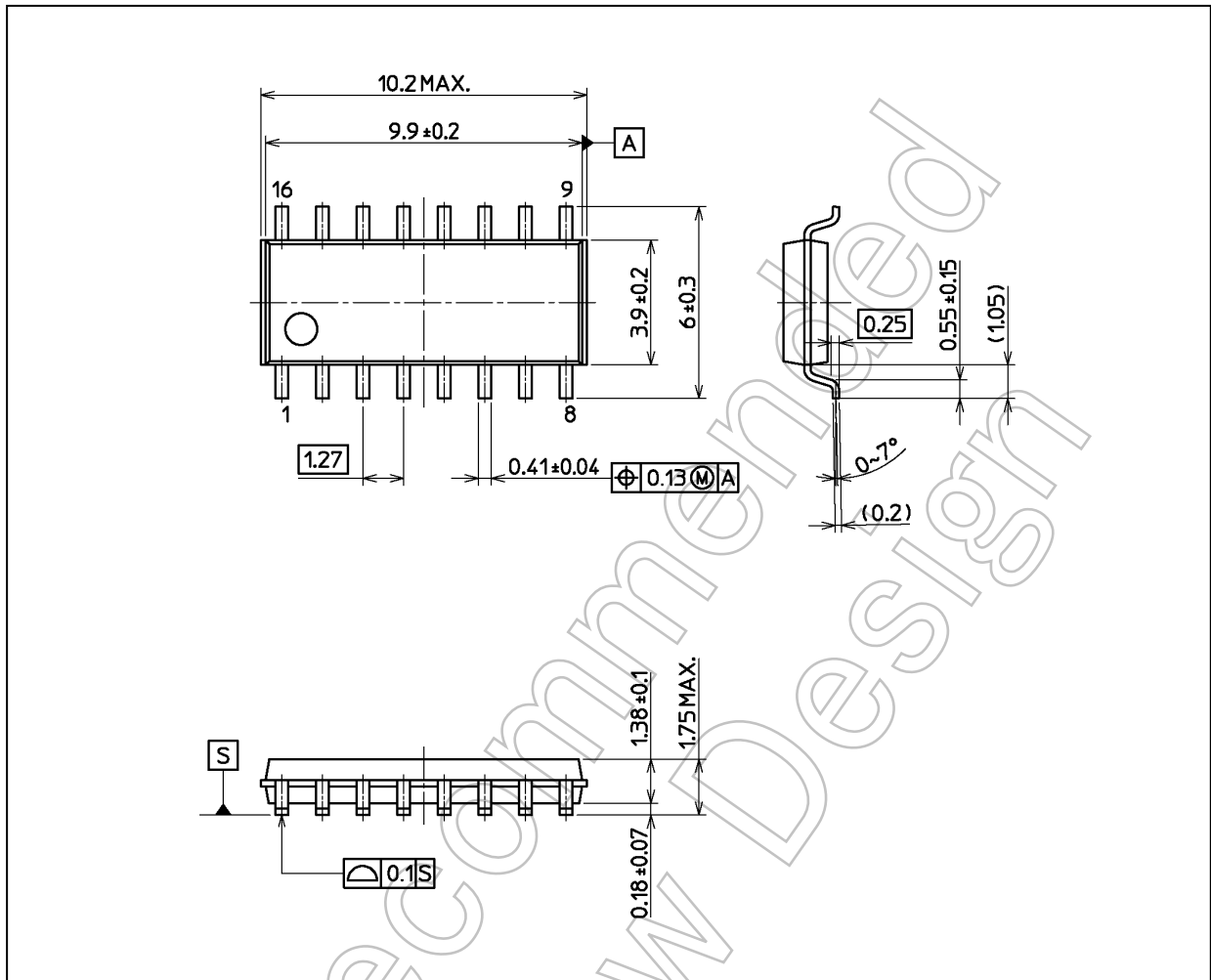

Figure 6 Cross Talk (between any two switches)

Package Dimensions

Unit: mm



Weight: 0.15 g (typ.)

Package Name(s)
Nickname: SOIC16

RESTRICTIONS ON PRODUCT USE

Toshiba Corporation and its subsidiaries and affiliates are collectively referred to as "TOSHIBA".

Hardware, software and systems described in this document are collectively referred to as "Product".

- TOSHIBA reserves the right to make changes to the information in this document and related Product without notice.
- This document and any information herein may not be reproduced without prior written permission from TOSHIBA. Even with TOSHIBA's written permission, reproduction is permissible only if reproduction is without alteration/omission.
- Though TOSHIBA works continually to improve Product's quality and reliability, Product can malfunction or fail. Customers are responsible for complying with safety standards and for providing adequate designs and safeguards for their hardware, software and systems which minimize risk and avoid situations in which a malfunction or failure of Product could cause loss of human life, bodily injury or damage to property, including data loss or corruption. Before customers use the Product, create designs including the Product, or incorporate the Product into their own applications, customers must also refer to and comply with (a) the latest versions of all relevant TOSHIBA information, including without limitation, this document, the specifications, the data sheets and application notes for Product and the precautions and conditions set forth in the "TOSHIBA Semiconductor Reliability Handbook" and (b) the instructions for the application with which the Product will be used with or for. Customers are solely responsible for all aspects of their own product design or applications, including but not limited to (a) determining the appropriateness of the use of this Product in such design or applications; (b) evaluating and determining the applicability of any information contained in this document, or in charts, diagrams, programs, algorithms, sample application circuits, or any other referenced documents; and (c) validating all operating parameters for such designs and applications.
TOSHIBA ASSUMES NO LIABILITY FOR CUSTOMERS' PRODUCT DESIGN OR APPLICATIONS.

- **PRODUCT IS NEITHER INTENDED NOR WARRANTED FOR USE IN EQUIPMENTS OR SYSTEMS THAT REQUIRE EXTRAORDINARILY HIGH LEVELS OF QUALITY AND/OR RELIABILITY, AND/OR A MALFUNCTION OR FAILURE OF WHICH MAY CAUSE LOSS OF HUMAN LIFE, BODILY INJURY, SERIOUS PROPERTY DAMAGE AND/OR SERIOUS PUBLIC IMPACT ("UNINTENDED USE").**

Except for specific applications as expressly stated in this document, Unintended Use includes, without limitation, equipment used in nuclear facilities, equipment used in the aerospace industry, lifesaving and/or life supporting medical equipment, equipment used for automobiles, trains, ships and other transportation, traffic signaling equipment, equipment used to control combustions or explosions, safety devices, elevators and escalators, and devices related to power plant.

IF YOU USE PRODUCT FOR UNINTENDED USE, TOSHIBA ASSUMES NO LIABILITY FOR PRODUCT.

For details, please contact your TOSHIBA sales representative or contact us via our website.

- Do not disassemble, analyze, reverse-engineer, alter, modify, translate or copy Product, whether in whole or in part.
- Product shall not be used for or incorporated into any products or systems whose manufacture, use, or sale is prohibited under any applicable laws or regulations.
- The information contained herein is presented only as guidance for Product use. No responsibility is assumed by TOSHIBA for any infringement of patents or any other intellectual property rights of third parties that may result from the use of Product. No license to any intellectual property right is granted by this document, whether express or implied, by estoppel or otherwise.
- **ABSENT A WRITTEN SIGNED AGREEMENT, EXCEPT AS PROVIDED IN THE RELEVANT TERMS AND CONDITIONS OF SALE FOR PRODUCT, AND TO THE MAXIMUM EXTENT ALLOWABLE BY LAW, TOSHIBA (1) ASSUMES NO LIABILITY WHATSOEVER, INCLUDING WITHOUT LIMITATION, INDIRECT, CONSEQUENTIAL, SPECIAL, OR INCIDENTAL DAMAGES OR LOSS, INCLUDING WITHOUT LIMITATION, LOSS OF PROFITS, LOSS OF OPPORTUNITIES, BUSINESS INTERRUPTION AND LOSS OF DATA, AND (2) DISCLAIMS ANY AND ALL EXPRESS OR IMPLIED WARRANTIES AND CONDITIONS RELATED TO SALE, USE OF PRODUCT, OR INFORMATION, INCLUDING WARRANTIES OR CONDITIONS OF MERCHANTABILITY, FITNESS FOR A PARTICULAR PURPOSE, ACCURACY OF INFORMATION, OR NONINFRINGEMENT.**
- Do not use or otherwise make available Product or related software or technology for any military purposes, including without limitation, for the design, development, use, stockpiling or manufacturing of nuclear, chemical, or biological weapons or missile technology products (mass destruction weapons). Product and related software and technology may be controlled under the applicable export laws and regulations including, without limitation, the Japanese Foreign Exchange and Foreign Trade Law and the U.S. Export Administration Regulations. Export and re-export of Product or related software or technology are strictly prohibited except in compliance with all applicable export laws and regulations.
- Please contact your TOSHIBA sales representative for details as to environmental matters such as the RoHS compatibility of Product. Please use Product in compliance with all applicable laws and regulations that regulate the inclusion or use of controlled substances, including without limitation, the EU RoHS Directive. **TOSHIBA ASSUMES NO LIABILITY FOR DAMAGES OR LOSSES OCCURRING AS A RESULT OF NONCOMPLIANCE WITH APPLICABLE LAWS AND REGULATIONS.**