

TOSHIBA CMOS Linear Integrated Circuit Silicon Monolithic

TCK106AF, TCK107AF, TCK108AF

1.0 A Load Switch IC with Slew Rate Control Driver in Small Package

The TCK106AF, TCK107AF and TCK108AF are load switch ICs for a general power management with slew rate control driver, featuring low switch ON resistance and wide input voltage operation from 1.1 to 5.5 V.

Switch ON resistance is only 63 mΩ typical at $V_{IN} = 5.0\text{ V}$, $I_{OUT} = -0.5\text{ A}$ condition and output current is available on 1.0 A. TCK107AF and TCK108AF feature output auto-discharge function.

These devices are available in SMV (2.8 mm x 2.9 mm Typ.) package.

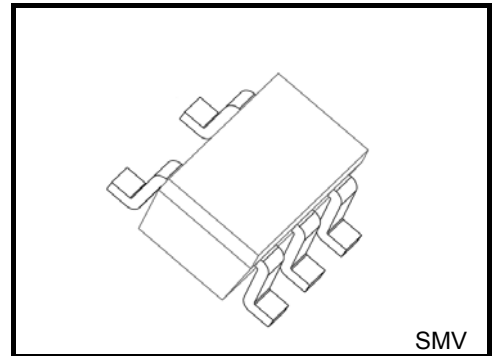

SMV (SOT-25)(SC-74A) : 16 mg (Typ.)

Feature

- Low ON resistance :
 - $R_{ON} = 63\text{ m}\Omega$ (Typ.) at $V_{IN} = 5.0\text{ V}$, $I_{OUT} = -0.5\text{ A}$
 - $R_{ON} = 71\text{ m}\Omega$ (Typ.) at $V_{IN} = 3.3\text{ V}$, $I_{OUT} = -0.5\text{ A}$
 - $R_{ON} = 101\text{ m}\Omega$ (Typ.) at $V_{IN} = 1.8\text{ V}$, $I_{OUT} = -0.5\text{ A}$
 - $R_{ON} = 175\text{ m}\Omega$ (Typ.) at $V_{IN} = 1.2\text{ V}$, $I_{OUT} = -0.2\text{ A}$
 - $R_{ON} = 223\text{ m}\Omega$ (Typ.) at $V_{IN} = 1.1\text{ V}$, $I_{OUT} = -0.2\text{ A}$
- Low Quiescent current
 - $I_Q = 110\text{ nA}$ (Typ.) at $V_{IN} = 5.5\text{ V}$, $I_{OUT} = 0\text{ mA}$
- High output current: $I_{OUT} = 1.0\text{ A}$
- Wide input voltage operation: $V_{IN} = 1.1\text{ to }5.5\text{ V}$
- Built in Slew rate control driver
- Built in Auto-discharge (TCK107AF and TCK108AF)
- Active High and Pull down connection between CONTROL and GND (TCK106AF and TCK107AF)
- Active Low (TCK108AF)
- General purpose package SMV(SOT-25) (SC-74A)

Pin Assignment (top view)

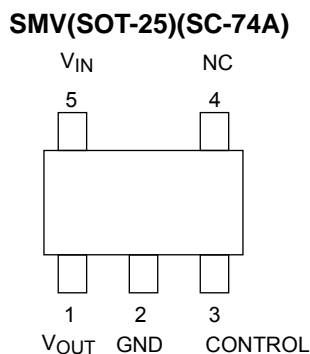

Top marking

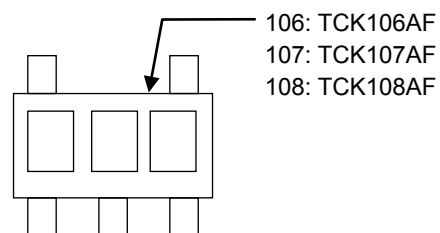

Start of commercial production
2016-01

Absolute Maximum Ratings (Ta = 25°C)

Characteristics	Symbol	Rating		Unit
Input voltage	V_{IN}	-0.3 to 6.0		V
Control voltage	V_{CT}	-0.3 to 6.0		V
Output voltage	V_{OUT}	-0.3 to $V_{IN} + 0.3$	(Note1)	V
Output current	I_{OUT}	DC	1.0	A
		Pulse	1.5	
Power dissipation	P_D	200		mW
		580		
Operating temperature range	T_{opr}	-40 to 85		°C
Junction teperature	T_j	150		°C
Storage temperature	T_{stg}	-55 to 150		°C

Note : Using continuously under heavy loads (e.g. the application of high temperature/current/voltage and the significant change in temperature, etc.) may cause this product to decrease in the reliability significantly even if the operating conditions (i.e. operating temperature/current/voltage, etc.) are within the absolute maximum ratings and the operating ranges. Please design the appropriate reliability upon reviewing the Toshiba Semiconductor Reliability Handbook (“Handling Precautions”/“Derating Concept and Methods”) and individual reliability data (i.e. reliability test report and estimated failure rate, etc).

Note 1: $V_{IN} + 0.3 \leq 6.0$ V

Note 2: 1 ms pulse, 1% duty cycle

Note 3: Unit Rating

Note 4: Rating at mounting on a board (FR4 board: 25.4 mm x 25.4 mm x 1.6 mm)

Block Diagram

TCK106AF, TCK107AF

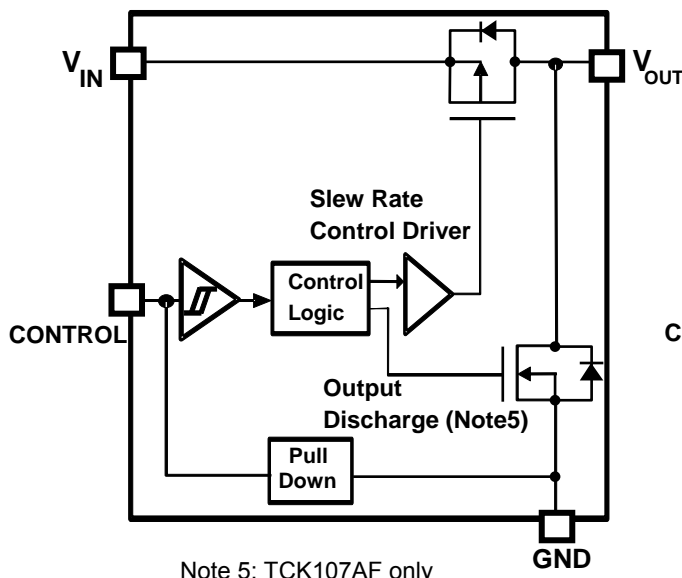

TCK108AF

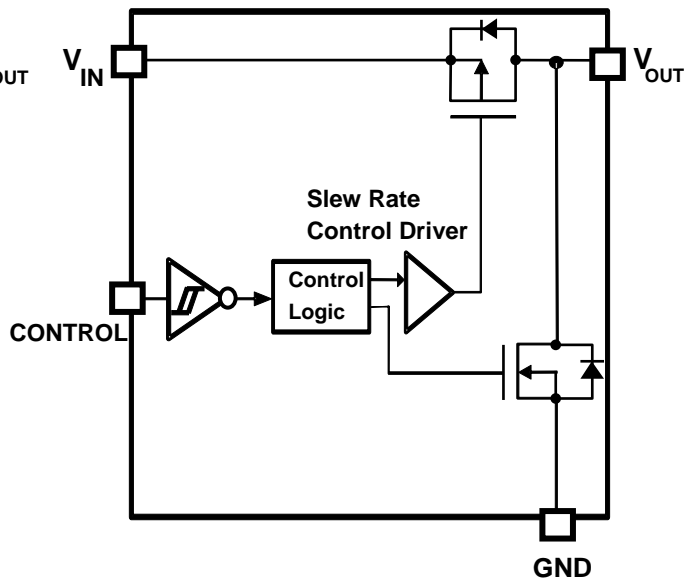

Operating conditions

Characteristics	Symbol	Condition	Min	Max	Unit
Input voltage	V_{IN}	—	1.1	5.5	V
Output current	I_{OUT}	—		1.0	A
CONTROL High-level input voltage	V_{IH}	$1.1\text{ V} \leq V_{IN} \leq 5.5\text{ V}$	0.9	—	V
CONTROL Low-level input voltage	V_{IL}		—	0.4	V

Electrical Characteristics

DC Characteristics (Ta = -40 to 85°C)

Characteristics	Symbol	Test Condition	Min	Typ.	Max	Unit
Quiescent current (ON state)	I_Q	$V_{IN} = V_{CT} = 5.5\text{ V}$, $I_{OUT} = 0\text{ mA}$	—	110	230	nA
		TCK106AF TCK107AF				
Standby current (OFF state)	$I_{Q(OFF)}$	$V_{IN} = 5.5\text{ V}$, $V_{CT} = 0\text{ V}$, $V_{OUT} = \text{OPEN}$ (Note6)	—	65	150	nA
		TCK106AF TCK107AF				
OFF-state switch current	$I_{SD(OFF)}$	$V_{IN} = V_{CT} = 5.5\text{ V}$, $V_{OUT} = \text{OPEN}$ (Note6)	—	14	1000	nA
		TCK108AF				
On resistance	R_{ON}	$V_{IN} = 5.0\text{ V}$, $I_{OUT} = -0.5\text{ A}$	—	63	90	mΩ
		$V_{IN} = 3.3\text{ V}$, $I_{OUT} = -0.5\text{ A}$	—	71	105	
		$V_{IN} = 1.8\text{ V}$, $I_{OUT} = -0.5\text{ A}$	—	101	155	
		$V_{IN} = 1.2\text{ V}$, $I_{OUT} = -0.2\text{ A}$	—	175	270	
		$V_{IN} = 1.1\text{ V}$, $I_{OUT} = -0.2\text{ A}$	—	223	—	
Discharge on resistance	R_{SD}	— (TCK107AF and TCK108AF)	—	100	—	Ω

Note 6: Except $I_{SD(OFF)}$ OFF-state switch current

AC Characteristics (Ta = 25°C)

V_{IN} = 1.2 V

Characteristics	Symbol	Test Condition (Figure 1)	Min	Typ.	Max	Unit	
V _{OUT} rise time	t _r	R _L = 500 Ω, C _L = 0.1 μF	—	290	—	μs	
V _{OUT} fall time	t _f	R _L = 500 Ω, C _L = 0.1 μF	TCK107AF	—	30	—	μs
			TCK108AF	—	104	—	
			TCK106AF	—	—	—	
Turn on delay	t _{ON}	R _L = 500 Ω, C _L = 0.1 μF	—	305	—	μs	
Turn off delay	t _{OFF}	R _L = 500 Ω, C _L = 0.1 μF	—	5	—	μs	

V_{IN} = 3.3 V

Characteristics	Symbol	Test Condition (Figure 1)	Min	Typ.	Max	Unit	
V _{OUT} rise time	t _r	R _L = 500 Ω, C _L = 0.1 μF	—	130	—	μs	
V _{OUT} fall time	t _f	R _L = 500 Ω, C _L = 0.1 μF	TCK107AF	—	25	—	μs
			TCK108AF	—	110	—	
			TCK106AF	—	—	—	
Turn on delay	t _{ON}	R _L = 500 Ω, C _L = 0.1 μF	—	100	—	μs	
Turn off delay	t _{OFF}	R _L = 500 Ω, C _L = 0.1 μF	—	10	—	μs	

AC Waveform

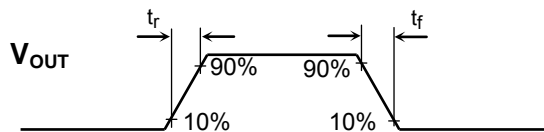

TCK106AF, TCK107AF

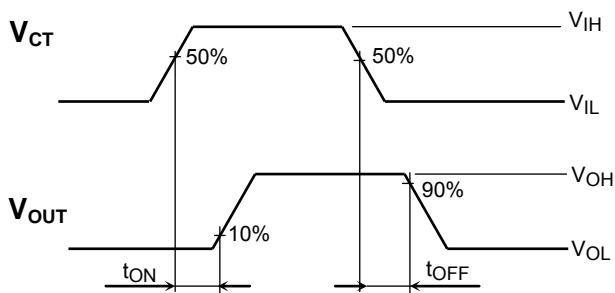

TCK108AF

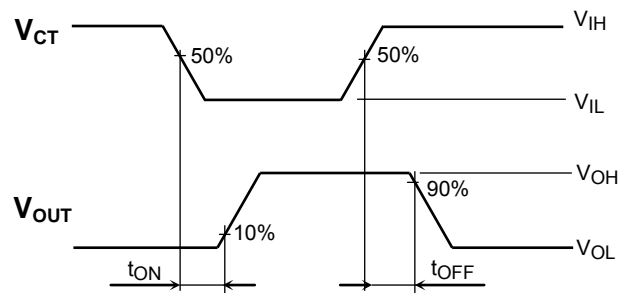
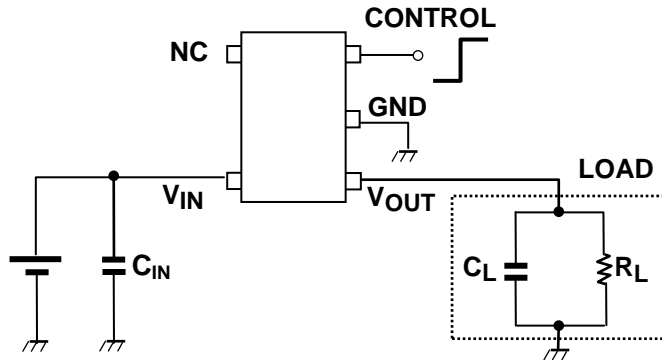

Figure 1 t_r, t_f, t_{ON}, t_{OFF} Waveforms

Application Note

1. Application circuit example (top view)

The figure below shows the recommended configuration for TCK106AF, TCK107AF and TCK108AF.



Part number	Control voltage	IC Operation
TCK106AF TCK107AF	HIGH	ON
	LOW	OFF
	OPEN	OFF
TCK108AF	HIGH	OFF
	LOW	ON

1) Input capacitor

An input capacitor (C_{IN}) is not necessary for the guaranteed operation of TCK106AF, TCK107AF and TCK108AF. However, it is recommended to use input capacitors to reduce voltage drop due to sharp changes in output current and also for improved stability of the power supply. When used, place C_{IN} as close to V_{IN} pin to improve stability of the power supply. Also, due to the C_{IN} selected, $V_{IN} < V_{OUT}$ may occur, causing a reverse current to flow through the body diode of the pass-through p-ch MOSFET of the load switch IC. In this case, a higher value for C_{IN} as compared to C_L is recommended.

2) Output capacitor

An output capacitor (C_{OUT}) is not necessary for the guaranteed operation of TCK106AF, TCK107AF and TCK108AF. However, there is a possibility of overshoot or undershoot caused by output load transient response, board layout and parasitic components of load switch IC. In this case, an output capacitor with C_{OUT} more than $0.1\mu F$ is recommended.

3) Control pin

A control pins for TCK106AF and TCK107AF are both Active High and TCK108AF is Active Low. These controls both the pass-through p-ch MOSFET and the discharge n-ch MOSFET (except TCK106AF), operated by the control voltage and Schmitt trigger. When the control voltage level is High (Low; TCK108AF), p-ch MOSFET is ON state and n-ch MOSFET is OFF state. When control voltage level is Low (High; TCK108AF), and the state of the MOSFETs is reversed. Also, pull down resistance equivalent to a few $M\Omega$ is connected between CONTROL and GND, thus the load switch IC is in OFF state even when CONTROL pin is OPEN(except TCK108AF). In addition, CONTROL pin has a tolerant function such that it can be used even if the control voltage is higher than the input voltage.

2. Power Dissipation

Both unit and board-mounted power dissipation ratings for TCK106AF, TCK107AF and TCK108AF are available in the Absolute Maximum Ratings table.

Power dissipation is measured on the board shown below.

①: Rating at mounting on a board

Board material: FR4 board

Board dimension: 25.4 mm × 25.4 mm × 1.6 mm

Copper area: 645 mm²

②: Unit Rating

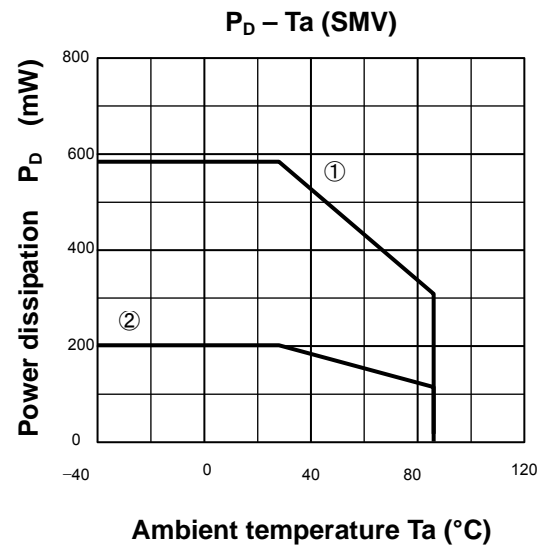

Please allow sufficient margin when designing a board pattern to fit the expected power dissipation. Also take into consideration the ambient temperature, input voltage, output current etc and applying the appropriate derating for allowable power dissipation during operation.

Representative Common Characteristics

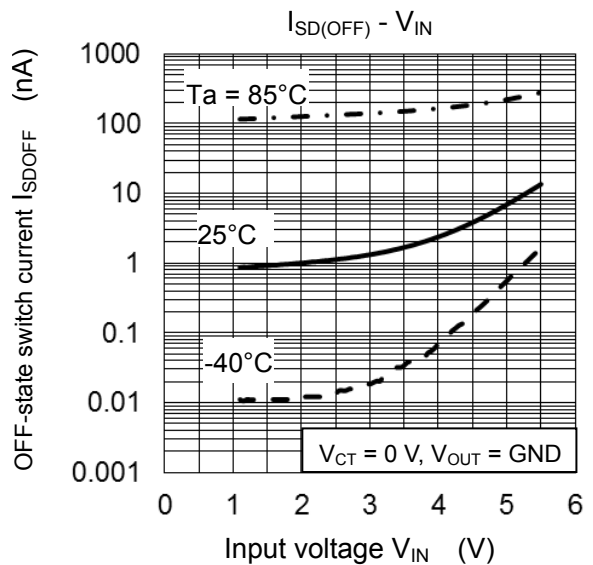
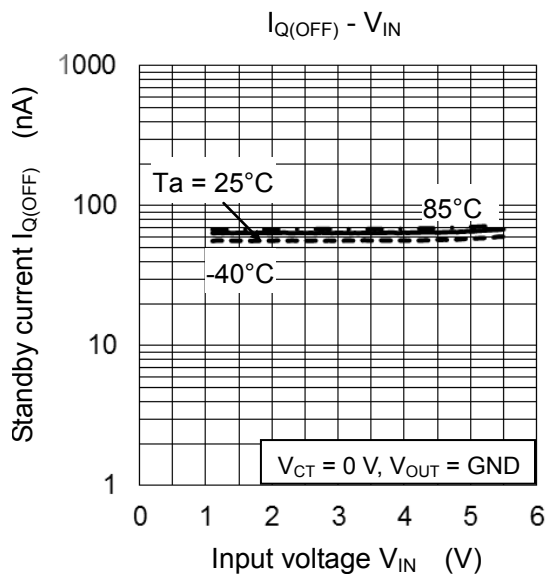
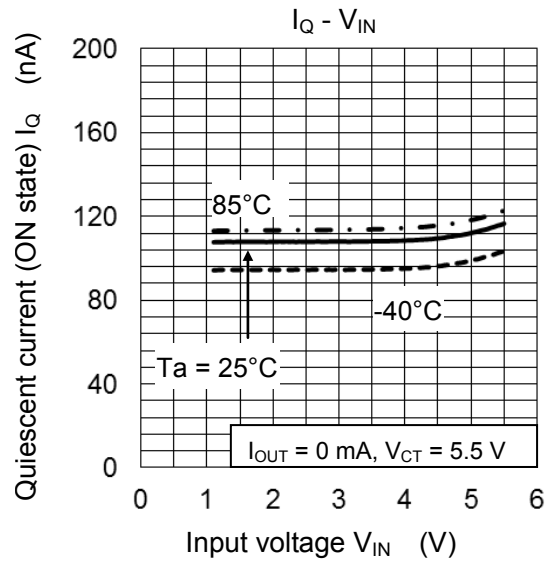
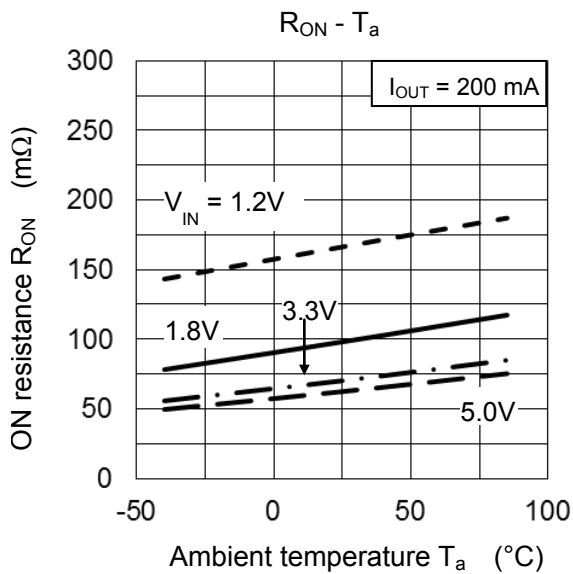
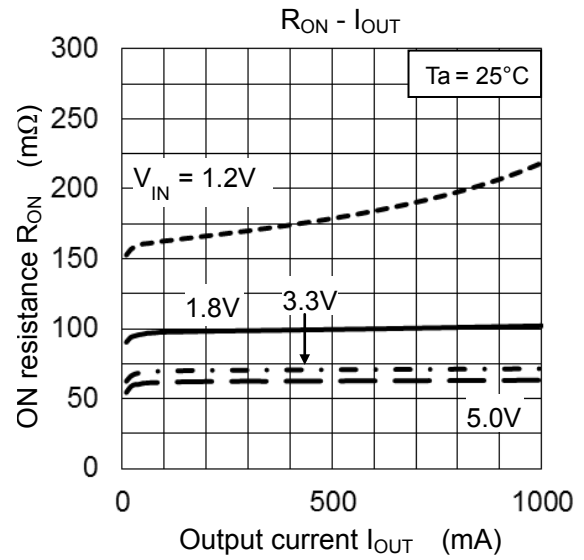
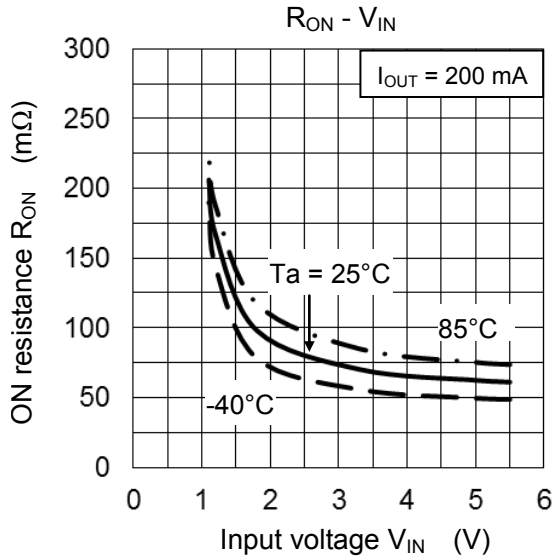

TCK107AF t_{ON} Response

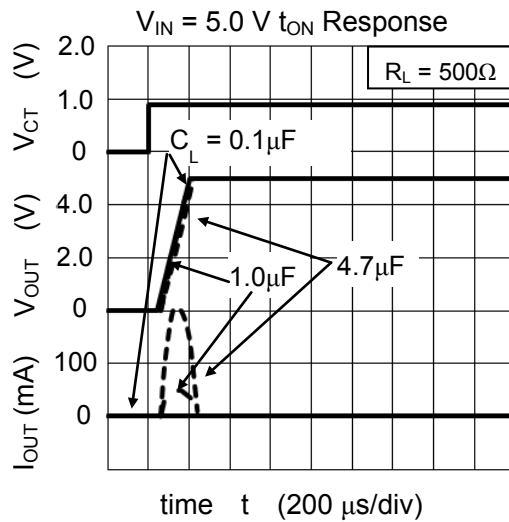
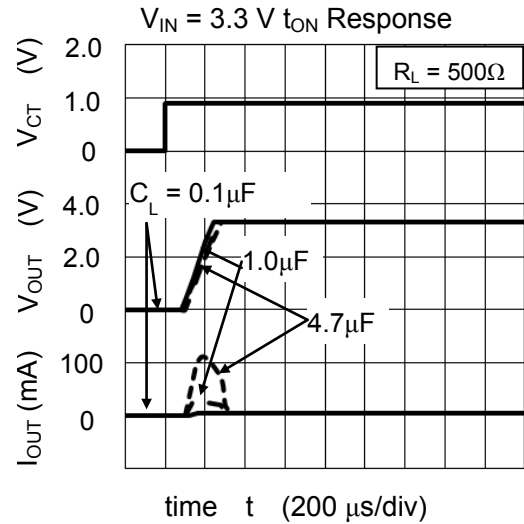
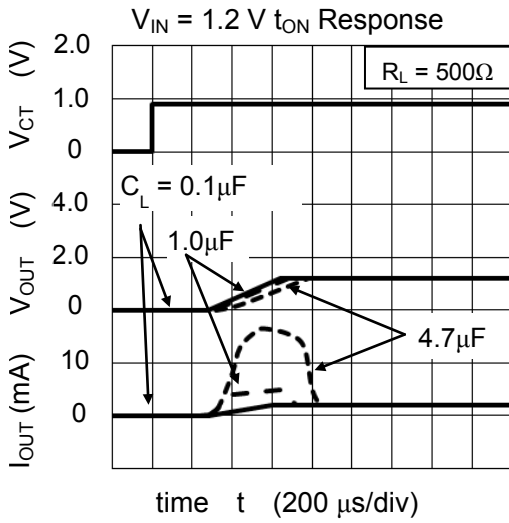

TCK106AF t_{OFF} Response

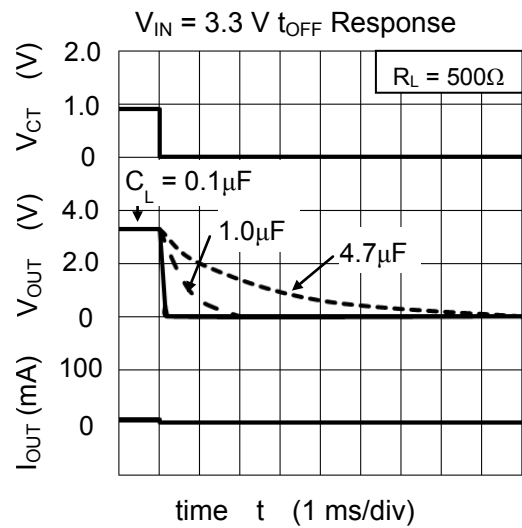
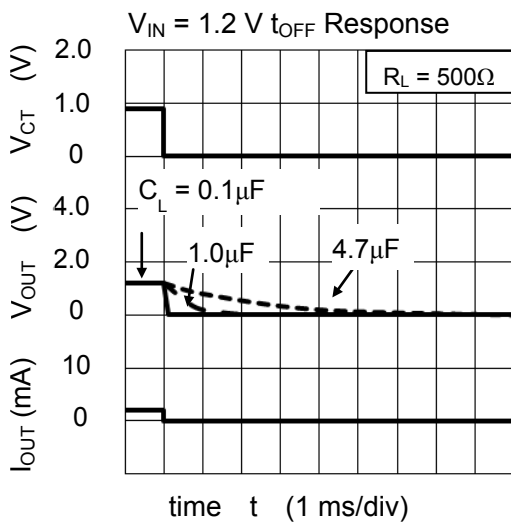

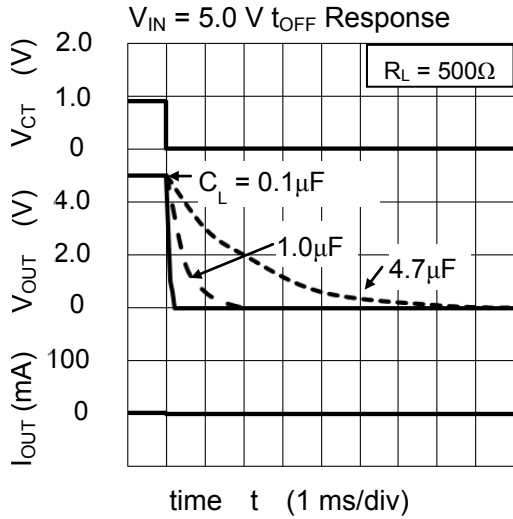

TCK107AF t_{OFF} Response

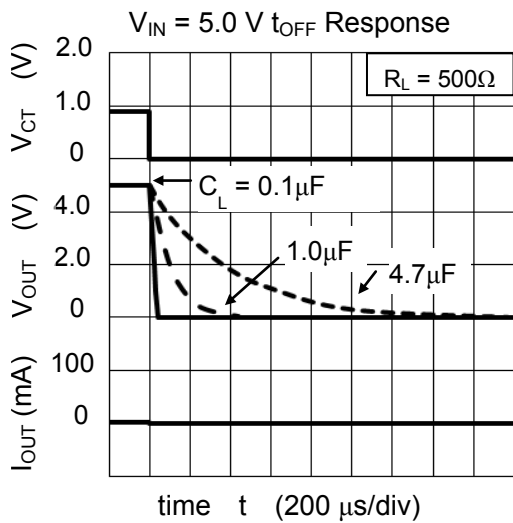
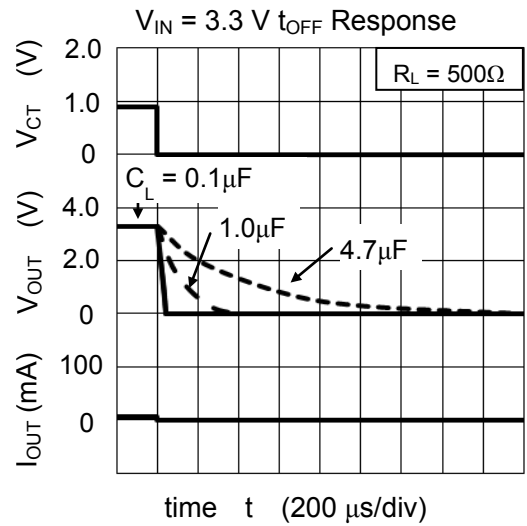
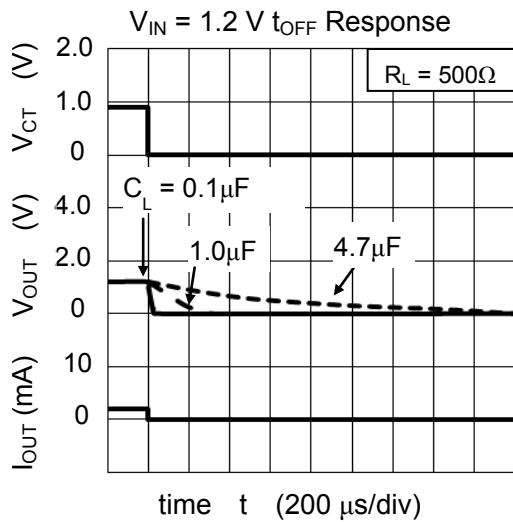

Package dimension

SMV (SOT-25)(SC-74A)

Unit: mm

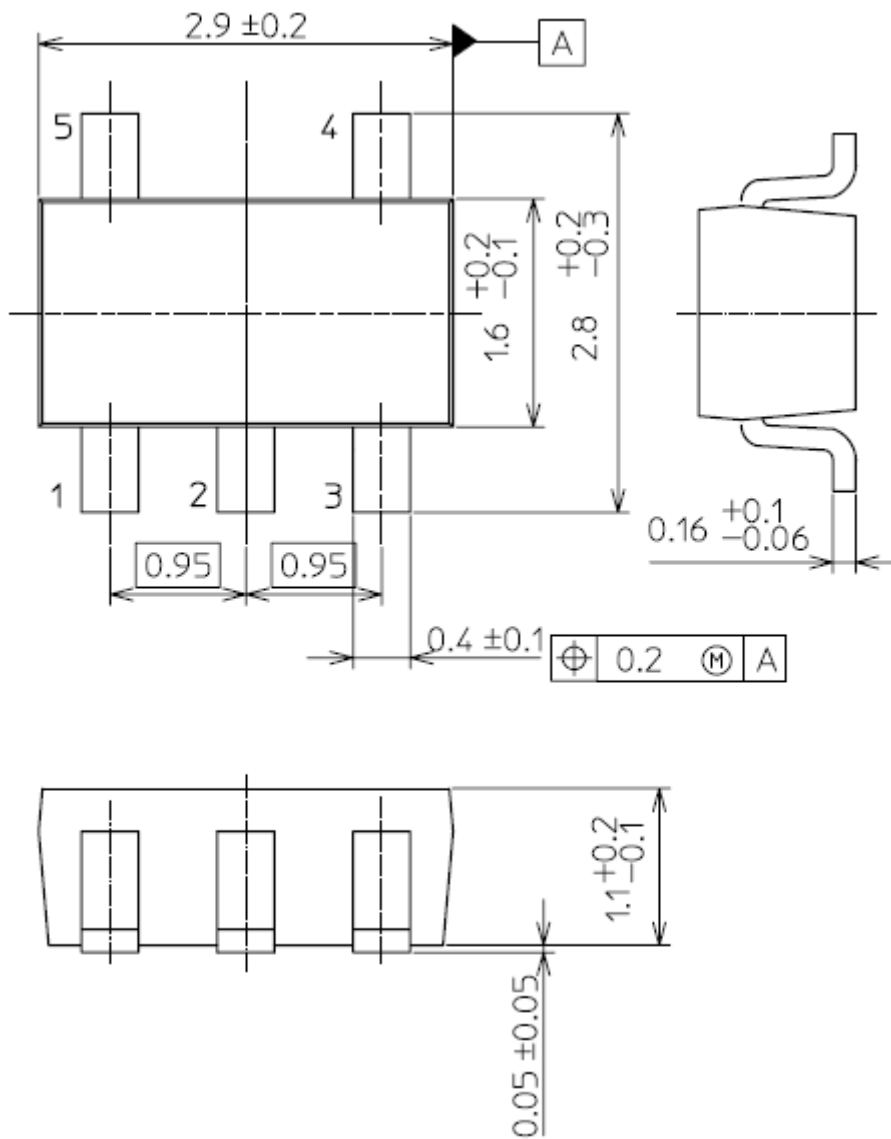

Weight : 16mg (Typ.)

Land pattern dimensions (for reference only)

Unit: mm

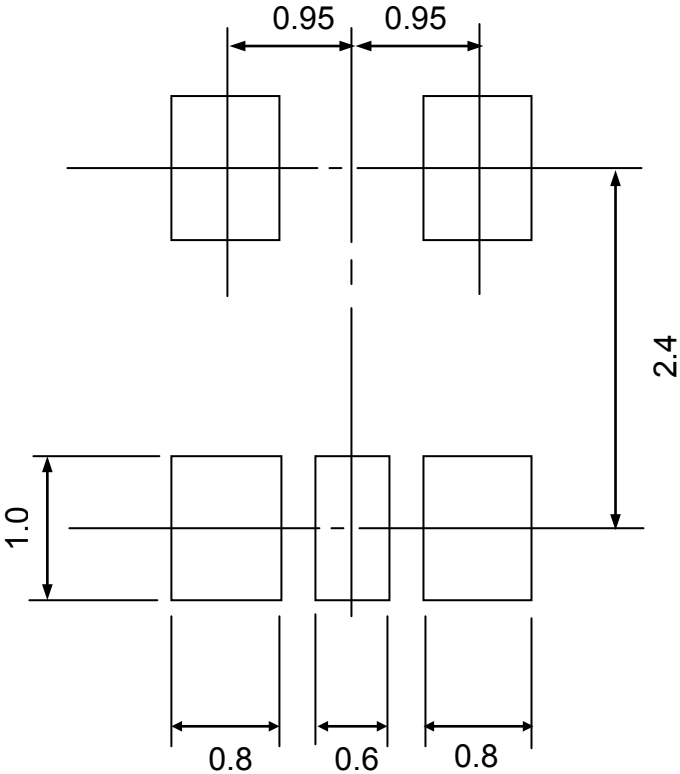

RESTRICTIONS ON PRODUCT USE

- Toshiba Corporation, and its subsidiaries and affiliates (collectively "TOSHIBA"), reserve the right to make changes to the information in this document, and related hardware, software and systems (collectively "Product") without notice.
- This document and any information herein may not be reproduced without prior written permission from TOSHIBA. Even with TOSHIBA's written permission, reproduction is permissible only if reproduction is without alteration/omission.
- Though TOSHIBA works continually to improve Product's quality and reliability, Product can malfunction or fail. Customers are responsible for complying with safety standards and for providing adequate designs and safeguards for their hardware, software and systems which minimize risk and avoid situations in which a malfunction or failure of Product could cause loss of human life, bodily injury or damage to property, including data loss or corruption. Before customers use the Product, create designs including the Product, or incorporate the Product into their own applications, customers must also refer to and comply with (a) the latest versions of all relevant TOSHIBA information, including without limitation, this document, the specifications, the data sheets and application notes for Product and the precautions and conditions set forth in the "TOSHIBA Semiconductor Reliability Handbook" and (b) the instructions for the application with which the Product will be used with or for. Customers are solely responsible for all aspects of their own product design or applications, including but not limited to (a) determining the appropriateness of the use of this Product in such design or applications; (b) evaluating and determining the applicability of any information contained in this document, or in charts, diagrams, programs, algorithms, sample application circuits, or any other referenced documents; and (c) validating all operating parameters for such designs and applications. **TOSHIBA ASSUMES NO LIABILITY FOR CUSTOMERS' PRODUCT DESIGN OR APPLICATIONS.**
- **PRODUCT IS NEITHER INTENDED NOR WARRANTED FOR USE IN EQUIPMENTS OR SYSTEMS THAT REQUIRE EXTRAORDINARILY HIGH LEVELS OF QUALITY AND/OR RELIABILITY, AND/OR A MALFUNCTION OR FAILURE OF WHICH MAY CAUSE LOSS OF HUMAN LIFE, BODILY INJURY, SERIOUS PROPERTY DAMAGE AND/OR SERIOUS PUBLIC IMPACT ("UNINTENDED USE").** Except for specific applications as expressly stated in this document, Unintended Use includes, without limitation, equipment used in nuclear facilities, equipment used in the aerospace industry, Class 3 medical devices, equipment used for automobiles, and military vehicles and munitions. **IF YOU USE PRODUCT FOR UNINTENDED USE, TOSHIBA ASSUMES NO LIABILITY FOR PRODUCT.** For details, please contact your TOSHIBA sales representative or contact us via our website.
- Do not disassemble, analyze, reverse-engineer, alter, modify, translate or copy Product, whether in whole or in part.
- Product shall not be used for or incorporated into any products or systems whose manufacture, use, or sale is prohibited under any applicable laws or regulations.
- The information contained herein is presented only as guidance for Product use. No responsibility is assumed by TOSHIBA for any infringement of patents or any other intellectual property rights of third parties that may result from the use of Product. No license to any intellectual property right is granted by this document, whether express or implied, by estoppel or otherwise.
- **ABSENT A WRITTEN SIGNED AGREEMENT, EXCEPT AS PROVIDED IN THE RELEVANT TERMS AND CONDITIONS OF SALE FOR PRODUCT, AND TO THE MAXIMUM EXTENT ALLOWABLE BY LAW, TOSHIBA (1) ASSUMES NO LIABILITY WHATSOEVER, INCLUDING WITHOUT LIMITATION, INDIRECT, CONSEQUENTIAL, SPECIAL, OR INCIDENTAL DAMAGES OR LOSS, INCLUDING WITHOUT LIMITATION, LOSS OF PROFITS, LOSS OF OPPORTUNITIES, BUSINESS INTERRUPTION AND LOSS OF DATA, AND (2) DISCLAIMS ANY AND ALL EXPRESS OR IMPLIED WARRANTIES AND CONDITIONS RELATED TO SALE, USE OF PRODUCT, OR INFORMATION, INCLUDING WARRANTIES OR CONDITIONS OF MERCHANTABILITY, FITNESS FOR A PARTICULAR PURPOSE, ACCURACY OF INFORMATION, OR NONINFRINGEMENT.**
- Do not use or otherwise make available Product or related software or technology for any military purposes, including without limitation, for the design, development, use, stockpiling or manufacturing of nuclear, chemical, or biological weapons or missile technology products (mass destruction weapons). Product and related software and technology may be controlled under the applicable export laws and regulations including, without limitation, the Japanese Foreign Exchange and Foreign Trade Law and the U.S. Export Administration Regulations. Export and re-export of Product or related software or technology are strictly prohibited except in compliance with all applicable export laws and regulations.
- Please contact your TOSHIBA sales representative for details as to environmental matters such as the RoHS compatibility of Product. Please use Product in compliance with all applicable laws and regulations that regulate the inclusion or use of controlled substances, including without limitation, the EU RoHS Directive. **TOSHIBA ASSUMES NO LIABILITY FOR DAMAGES OR LOSSES OCCURRING AS A RESULT OF NONCOMPLIANCE WITH APPLICABLE LAWS AND REGULATIONS.**