

74HCT4053D

1. Functional Description

- Triple 2-Channel Analog Multiplexer/Demultiplexer

2. General

The 74HCT4053D are high speed CMOS ANALOG MULTIPLEXER/DEMULTIPLEXER fabricated with silicon gate C²MOS technology. They achieve the high speed operation similar to equivalent LSTTL while maintaining the CMOS low power dissipation.

This device may be used as a level converter for interfacing TTL or NMOS to High Speed CMOS. This inputs are compatible with TTL, NMOS and CMOS output voltage levels.

The 74HCT4053D has a 2 channel × 3 configuration.

The digital signal to the control terminal turns "ON" the corresponding switch of each channel a large amplitude signal ($V_{CC} - V_{EE}$) can then be switched by the small logical amplitude ($V_{CC} - GND$) control signal.

For example, in the case of $V_{CC} = 5\text{ V}$, $GND = 0\text{ V}$, $V_{EE} = -5\text{ V}$, signals between -5 V and $+5\text{ V}$ can be switched from the logical circuit with a single power supply of 5 V. As the ON-resistance of each switch is low, they can be connected to circuits with low input impedance.

All inputs are equipped with protection circuits against static discharge or transient excess voltage.

3. Features

- (1) Wide operating temperature range: $T_{opr} = -40$ to $125\text{ }^{\circ}\text{C}$ (Note 1)
- (2) Low power dissipation: $I_{CC} = 4.0\text{ }\mu\text{A}$ (max) ($V_{CC} = 5.5\text{ V}$, $V_{EE} = GND$, $T_a = 25\text{ }^{\circ}\text{C}$)
- (3) Compatible with TTL output: $V_{IH} = 2.0\text{ V}$ (min), $V_{IL} = 0.8\text{ V}$ (max)
- (4) Wide interfacing ability: LSTTL, NMOS, CMOS
- (5) Low ON-resistance: $R_{ON} = 50\text{ }\Omega$ (typ.) at $V_{CC} - V_{EE} = 9\text{ V}$
- (6) High degree of linearity: $THD = 0.020\text{ }\%$ (typ.) at $V_{CC} - V_{EE} = 9\text{ V}$
- (7) Pin and function compatible with 4053B

Note 1: Operating Range spec of $T_{opr} = -40\text{ }^{\circ}\text{C}$ to $125\text{ }^{\circ}\text{C}$ is applicable only for the products which manufactured after July 2020.

4. Packaging

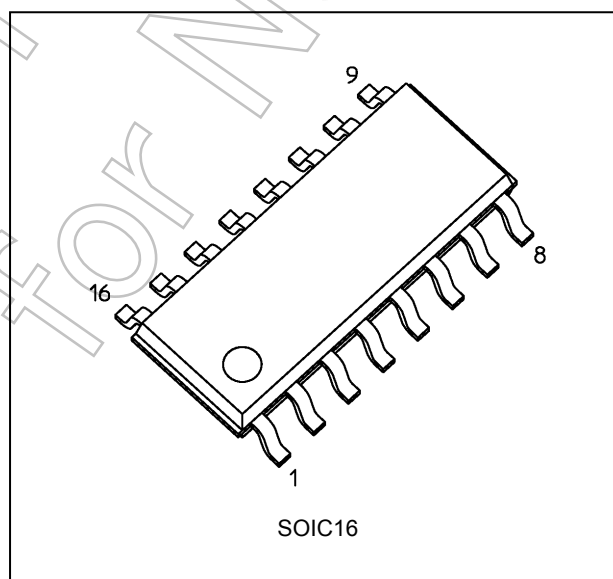

Start of commercial production

2020-07

5. Pin Assignment

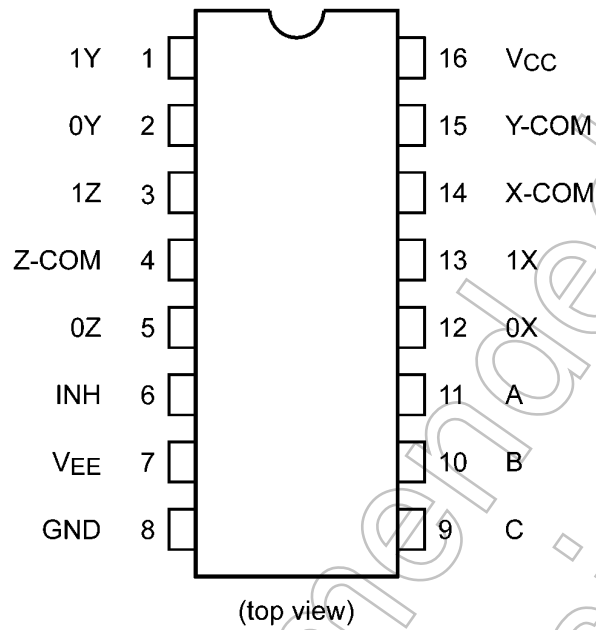

6. IEC Logic Symbol

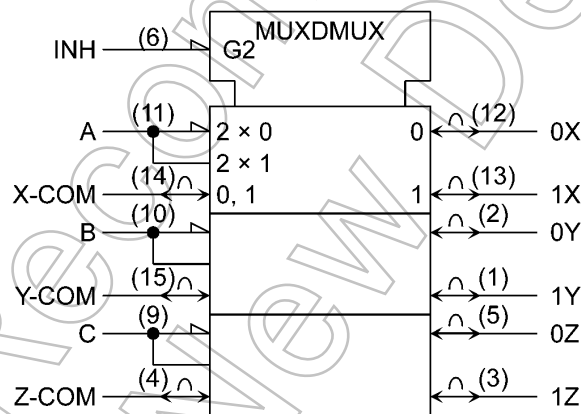

7. Marking

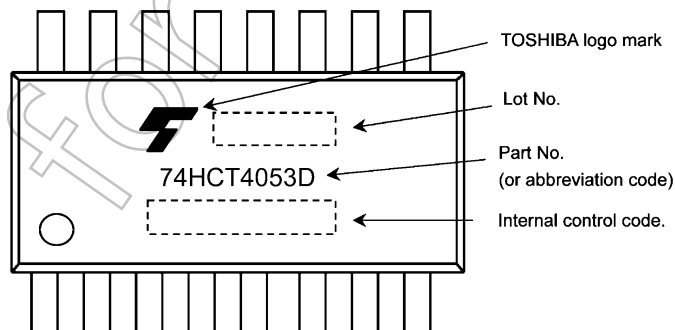

8. System Diagram

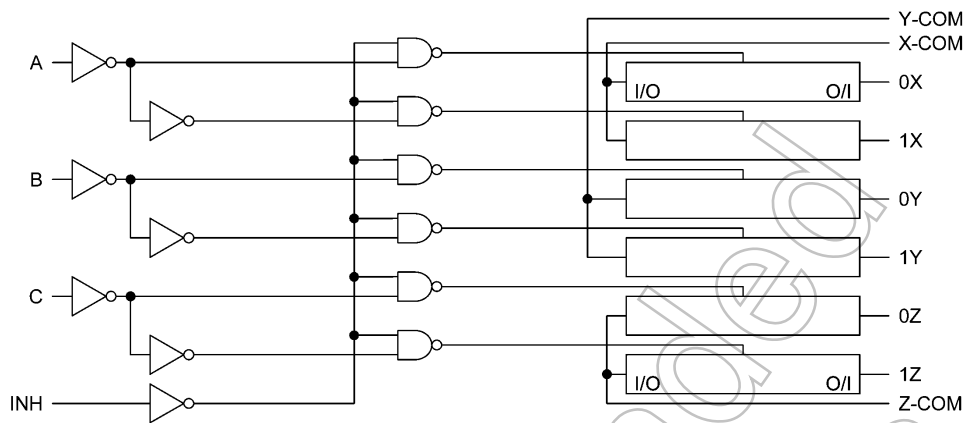

9. Truth Table

Input Inhibit	Input C	Input B	Input A	ON Channel
L	L	L	L	0X, 0Y, 0Z
L	L	L	H	1X, 0Y, 0Z
L	L	H	L	0X, 1Y, 0Z
L	L	H	H	1X, 1Y, 0Z
L	H	L	L	0X, 0Y, 1Z
L	H	L	H	1X, 0Y, 1Z
L	H	H	L	0X, 1Y, 1Z
L	H	H	H	1X, 1Y, 1Z
H	X	X	X	None

X: Don't care

10. Absolute Maximum Ratings (Note)

Characteristics	Symbol	Note	Rating	Unit
Supply voltage	V_{CC}		-0.5 to 13.0	V
	$V_{CC}-V_{EE}$		-0.5 to 13.0	
Input voltage	V_{IN}		-0.5 to $V_{CC} + 0.5$	V
Switch I/O voltage	$V_{I/O}$		$V_{EE} - 0.5$ to $V_{CC} + 0.5$	V
Input diode current	I_{IK}		± 20	mA
I/O diode current	$I_{I/OK}$		± 20	mA
Switch through current	I_T		± 25	mA
V_{CC} /ground current	I_{CC}		± 50	mA
Power dissipation	P_D	(Note 1)	500	mW
Storage temperature	T_{stg}		-65 to 150	$^{\circ}C$

Note: Exceeding any of the absolute maximum ratings, even briefly, lead to deterioration in IC performance or even destruction.

Using continuously under heavy loads (e.g. the application of high temperature/current/voltage and the significant change in temperature, etc.) may cause this product to decrease in the reliability significantly even if the operating conditions (i.e. operating temperature/current/voltage, etc.) are within the absolute maximum ratings and the operating ranges.

Please design the appropriate reliability upon reviewing the Toshiba Semiconductor Reliability Handbook ("Handling Precautions"/"Derating Concept and Methods") and individual reliability data (i.e. reliability test report and estimated failure rate, etc).

Note 1: P_D derates linearly with -8 mW/ $^{\circ}C$ above 85 $^{\circ}C$.

11. Operating Ranges (Note)

Characteristics	Symbol	Note	Rating	Unit
Supply voltage	V_{CC}		4.5 to 5.5	V
	V_{EE}		-7.5 to 0	
	$V_{CC}-V_{EE}$		4.5 to 12.0	
Input voltage	V_{IN}		0 to V_{CC}	V
Switch I/O voltage	$V_{I/O}$		V_{EE} to V_{CC}	V
Operating temperature	T_{opr}	(Note 1)	-40 to 125	$^{\circ}C$
Input rise and fall times	t_r, t_f		0 to 50	μs

Note: The operating ranges must be maintained to ensure the normal operation of the device.

Unused inputs must be tied to either V_{CC} or GND.

Note 1: Operating Range spec of $T_{opr} = -40^{\circ}C$ to $125^{\circ}C$ is applicable only for the products which manufactured after July 2020.

12. Electrical Characteristics

12.1. DC Characteristics (Unless otherwise specified, $T_a = 25\text{ }^\circ\text{C}$)

Characteristics	Symbol	Test Condition	V_{EE} (V)	V_{CC} (V)	Min	Typ.	Max	Unit
High-level input voltage	V_{IH}	—		4.5 to 5.5	2.0	—	—	V
Low-level input voltage	V_{IL}	—		4.5 to 5.5	—	—	0.8	V
ON-resistance	R_{ON}	$V_{IN} = V_{IH}$ or V_{IL} $V_{I/O} = V_{CC}$ to V_{EE} $I_{I/O} \leq 2\text{ mA}$	GND	4.5	—	85	180	Ω
			-4.5	4.5	—	55	120	
			-5.5	5.5	—	50	110	
		$V_{IN} = V_{IH}$ or V_{IL} $V_{I/O} = V_{CC}$ or V_{EE} $I_{I/O} \leq 2\text{ mA}$	GND	4.5	—	70	150	
			-4.5	4.5	—	50	100	
			-5.5	5.5	—	45	90	
Difference of ON-resistance between switches	ΔR_{ON}	$V_{IN} = V_{IH}$ or V_{IL} $V_{I/O} = V_{CC}$ to V_{EE} $I_{I/O} \leq 2\text{ mA}$	GND	4.5	—	10	30	Ω
			-4.5	4.5	—	5	12	
			-5.5	5.5	—	5	11	
Input/Output leakage current (Switch OFF)	I_{OFF}	$V_{OS} = V_{CC}$ or GND $V_{IS} = \text{GND}$ or V_{CC} $V_{IN} = V_{IH}$ or V_{IL}	GND	5.5	—	—	± 0.06	μA
			-5.5	5.5	—	—	± 0.1	
Input/Output leakage current (Switch ON)	$I_{I/O}$	$V_{OS} = V_{CC}$ or GND $V_{IN} = V_{IH}$ or V_{IL}	GND	5.5	—	—	± 0.06	μA
			-5.5	5.5	—	—	± 0.1	
Control input leakage current	I_{IN}	$V_{IN} = V_{CC}$ or GND	GND	5.5	—	—	± 0.1	μA
Quiescent supply current	I_{CC}	$V_{IN} = V_{CC}$ or GND	GND	5.5	—	—	4.0	μA
			-5.5	5.5	—	—	8.0	
	I_{CC}	Per input: $V_{IN} = 0.5\text{ V}$ or 2.4 V Other input: V_{CC} or GND	GND	5.5	—	—	2.0	mA

12.2. DC Characteristics (Unless otherwise specified, $T_a = -40$ to $85\text{ }^\circ\text{C}$)

Characteristics	Symbol	Test Condition	V_{EE} (V)	V_{CC} (V)	Min	Max	Unit
High-level input voltage	V_{IH}	—		4.5 to 5.5	2.0	—	V
Low-level input voltage	V_{IL}	—		4.5 to 5.5	—	0.8	V
ON-resistance	R_{ON}	$V_{IN} = V_{IH}$ or V_{IL} $V_{I/O} = V_{CC}$ to V_{EE} $I_{I/O} \leq 2\text{ mA}$	GND	4.5	—	225	Ω
			-4.5	4.5	—	150	
			-5.5	5.5	—	140	
		$V_{IN} = V_{IH}$ or V_{IL} $V_{I/O} = V_{CC}$ or V_{EE} $I_{I/O} \leq 2\text{ mA}$	GND	4.5	—	190	
			-4.5	4.5	—	125	
			-5.5	5.5	—	115	
Difference of ON-resistance between switches	ΔR_{ON}	$V_{IN} = V_{IH}$ or V_{IL} $V_{I/O} = V_{CC}$ to V_{EE} $I_{I/O} \leq 2\text{ mA}$	GND	4.5	—	35	Ω
			-4.5	4.5	—	15	
			-5.5	5.5	—	14	
Input/Output leakage current (Switch OFF)	I_{OFF}	$V_{OS} = V_{CC}$ or GND $V_{IS} = \text{GND}$ or V_{CC} $V_{IN} = V_{IH}$ or V_{IL}	GND	5.5	—	± 0.6	μA
			-5.5	5.5	—	± 1.0	
Input/Output leakage current (Switch ON)	$I_{I/O}$	$V_{OS} = V_{CC}$ or GND $V_{IN} = V_{IH}$ or V_{IL}	GND	5.5	—	± 0.6	μA
			-5.5	5.5	—	± 1.0	
Control input leakage current	I_{IN}	$V_{IN} = V_{CC}$ or GND	GND	5.5	—	± 1.0	μA
Quiescent supply current	I_{CC}	$V_{IN} = V_{CC}$ or GND	GND	5.5	—	40.0	μA
			-5.5	5.5	—	80.0	
	I_{CC}	Per input: $V_{IN} = 0.5\text{ V}$ or 2.4 V Other input: V_{CC} or GND	GND	5.5	—	2.9	mA

12.3. DC Characteristics (Note) (Unless otherwise specified, $T_a = -40$ to 125 °C)

Characteristics	Symbol	Test Condition	V_{EE} (V)	V_{CC} (V)	Min	Max	Unit
High-level input voltage	V_{IH}	—		4.5 to 5.5	2.0	—	V
Low-level input voltage	V_{IL}	—		4.5 to 5.5	—	0.8	V
ON-resistance	R_{ON}	$V_{IN} = V_{IH}$ or V_{IL} $V_{I/O} = V_{CC}$ to V_{EE} $I_{I/O} \leq 2$ mA	GND	4.5	—	255	Ω
			-4.5	4.5	—	170	
			-5.5	5.5	—	160	
		$V_{IN} = V_{IH}$ or V_{IL} $V_{I/O} = V_{CC}$ or V_{EE} $I_{I/O} \leq 2$ mA	GND	4.5	—	220	Ω
			-4.5	4.5	—	145	
			-5.5	5.5	—	135	
Difference of ON-resistance between switches	ΔR_{ON}	$V_{IN} = V_{IH}$ or V_{IL} $V_{I/O} = V_{CC}$ to V_{EE} $I_{I/O} \leq 2$ mA	GND	4.5	—	35	Ω
			-4.5	4.5	—	15	
			-5.5	5.5	—	14	
Input/Output leakage current (Switch OFF)	I_{OFF}	$V_{OS} = V_{CC}$ or GND $V_{IS} = GND$ to V_{CC} $V_{IN} = V_{IH}$ or V_{IL}	GND	5.5	—	± 3.0	μA
			-5.5	5.5	—	± 5.0	
Input/Output leakage current (Switch ON)	$I_{I/O}$	$V_{OS} = V_{CC}$ or GND $V_{IN} = V_{IH}$ or V_{IL}	GND	5.5	—	± 3.0	μA
			-5.5	5.5	—	± 5.0	
Control input leakage current	I_{IN}	$V_{IN} = V_{CC}$ or GND	GND	5.5	—	± 1.0	μA
Quiescent supply current	I_{CC}	$V_{IN} = V_{CC}$ or GND	GND	5.5	—	80.0	μA
			-5.5	5.5	—	160.0	
		Per input: $V_{IN} = 0.5$ V or 2.4 V Other input: V_{CC} or GND	GND	5.5	—	2.9	mA

Note: Operating Range spec of $T_{opr} = -40$ °C to 125 °C is applicable only for the products which manufactured after July 2020.

12.4. AC Characteristics

(Unless otherwise specified, $C_L = 50$ pF, $T_a = 25$ °C, Input: $t_r = t_f = 6$ ns)

Characteristics	Symbol	Test Condition	V_{EE} (V)	V_{CC} (V)	Min	Typ.	Max	Unit
Phase difference between input to output	$\phi_{I/O}$	—	GND	4.5	—	6	12	ns
			GND	5.5	—	5	11	
Output enable time	t_{PZL}, t_{PZH}	$R_L = 1$ k Ω Figure 1	GND	4.5	—	33	60	ns
			GND	5.5	—	26	45	
Output disable time	t_{PLZ}, t_{PHZ}	$R_L = 1$ k Ω Figure 1	GND	4.5	—	45	65	ns
			GND	5.5	—	37	59	
Control input capacitance	C_{IN}	—	—	—	—	5	10	pF
Common terminal capacitance	C_{IS}	Figure 2	-5.0	5.0	—	11	20	pF
Switch terminal capacitance	C_{OS}	Figure 2	-5.0	5.0	—	7	15	pF
Feedthrough capacitance	C_{IOS}	Figure 2	-5.0	5.0	—	0.75	2	pF
Power dissipation capacitance	C_{PD}	Figure 2 (Note 1)	GND	5.0	—	10	—	pF

Note 1: C_{PD} is defined as the value of the internal equivalent capacitance which is calculated from the operating current consumption without load. Average operating current can be obtained by the equation.

$$I_{CC(opr)} = C_{PD} \times V_{CC} \times f_{IN} + I_{CC}$$

12.5. AC Characteristics (Unless otherwise specified, $C_L = 50 \text{ pF}$, $T_a = -40 \text{ to } 85 \text{ }^\circ\text{C}$, Input: $t_r = t_f = 6 \text{ ns}$)

Characteristics	Symbol	Test Condition	V_{EE} (V)	V_{CC} (V)	Min	Max	Unit
Phase difference between input to output	$\phi_{I/O}$	—	GND	4.5	—	15	ns
			GND	5.5	—	13	
Output enable time	t_{PZL}, t_{PZH}	$R_L = 1 \text{ k}\Omega$ Figure 1	GND	4.5	—	63	ns
			GND	5.5	—	57	
Output disable time	t_{PLZ}, t_{PHZ}	$R_L = 1 \text{ k}\Omega$ Figure 1	GND	4.5	—	81	ns
			GND	5.5	—	73	
Control input capacitance	C_{IN}	—	—	—	—	10	pF
Common terminal capacitance	C_{IS}	Figure 2	-5.0	5.0	—	20	pF
Switch terminal capacitance	C_{OS}	Figure 2	-5.0	5.0	—	15	pF
Feedthrough capacitance	C_{IOS}	Figure 2	-5.0	5.0	—	2	pF

12.6. AC Characteristics (Note) (Unless otherwise specified, $C_L = 50 \text{ pF}$, $T_a = -40 \text{ to } 125 \text{ }^\circ\text{C}$, Input: $t_r = t_f = 6 \text{ ns}$)

Characteristics	Symbol	Test Condition	V_{EE} (V)	V_{CC} (V)	Min	Max	Unit
Phase difference between input to output	$\phi_{I/O}$	—	GND	4.5	—	17	ns
			GND	5.5	—	14	
Output enable time	t_{PZL}, t_{PZH}	$R_L = 1 \text{ k}\Omega$ Figure 1	GND	4.5	—	65	ns
			GND	5.5	—	65	
Output disable time	t_{PLZ}, t_{PHZ}	$R_L = 1 \text{ k}\Omega$ Figure 1	GND	4.5	—	92	ns
			GND	5.5	—	82	
Control input capacitance	C_{IN}	—	—	—	—	10	pF
Common terminal capacitance	C_{IS}	Figure 2	-5.0	5.0	—	20	pF
Switch terminal capacitance	C_{OS}	Figure 2	-5.0	5.0	—	15	pF
Feedthrough capacitance	C_{IOS}	Figure 2	-5.0	5.0	—	2	pF

Note: Operating Range spec of $T_{opr} = -40 \text{ }^\circ\text{C}$ to $125 \text{ }^\circ\text{C}$ is applicable only for the products which manufactured after July 2020.

Not for New

12.7. Analog Switch Characteristics ($T_a = 25\text{ }^\circ\text{C}$) (Note)

Characteristics	Symbol	Test Condition	V_{EE} (V)	V_{CC} (V)	Typ.	Unit	
Sine Wave Distortion	THD	$R_L = 10\text{ k}\Omega$, $C_L = 50\text{ pF}$ $f_{IN} = 1\text{ kHz}$	$V_{IN} = 8.0\text{ V}_{p-p}$	-4.5	4.5	0.020	%
			$V_{IN} = 11.0\text{ V}_{p-p}$	-5.5	5.5	0.019	
Maximum frequency response	$f_{MAX(I/O)}$	Adjust f_{IN} voltage to obtain 0 dBm at V_{OS} Increase f_{IN} frequency until dB meter reads -3 dB $R_L = 50\text{ }\Omega$, $C_L = 10\text{ pF}$ $f_{IN} = 1\text{ MHz}$, sine wave Figure 3	(Note 1)	-4.5	4.5	190	MHz
			(Note 2)			150	
			(Note 1)	-5.5	5.5	200	
			(Note 2)			180	
Feed through attenuation (switch OFF)	FTH	V_{IN} is centered at $(V_{CC} - V_{EE})/2$ Adjust input for 0 dBm. $R_L = 600\text{ }\Omega$, $C_L = 50\text{ pF}$, $f_{IN} = 1\text{ MHz}$, sine wave Figure 4	-4.5	4.5	-50	dB	
			-5.5	5.5	-50		
Crosstalk (control input to signal output)	X_{talk}	$R_L = 600\text{ }\Omega$, $C_L = 50\text{ pF}$, $f_{IN} = 1\text{ MHz}$, square wave ($t_r = t_f = 6\text{ ns}$) Figure 5	-4.5	4.5	140	mV	
			-5.5	5.5	180		
Crosstalk (between any switches)	X_{talk}	Adjust V_{IN} to obtain 0 dBm at input. $R_L = 600\text{ }\Omega$, $C_L = 50\text{ pF}$, $f_{IN} = 1\text{ MHz}$, sine wave Figure 6	-4.5	4.5	-50	dB	
			-5.5	5.5	-50		
	X_{talk}	$R_L = 50\text{ }\Omega$, $C_L = 15\text{ pF}$, $f_{IN} = 100\text{ KHz}$, $V_{SWITCH} = 1\text{ V}_{RMS}$ Figure 6	-4.5	4.5	-90	dB	

Note: These characteristics are determined by design of devices.

Note 1: Input COMMON terminal, and measured at SWITCH terminal.

Note 2: Input SWITCH terminal, and measured at COMMON terminal.

Not Recommended for New

13. AC Test Circuit

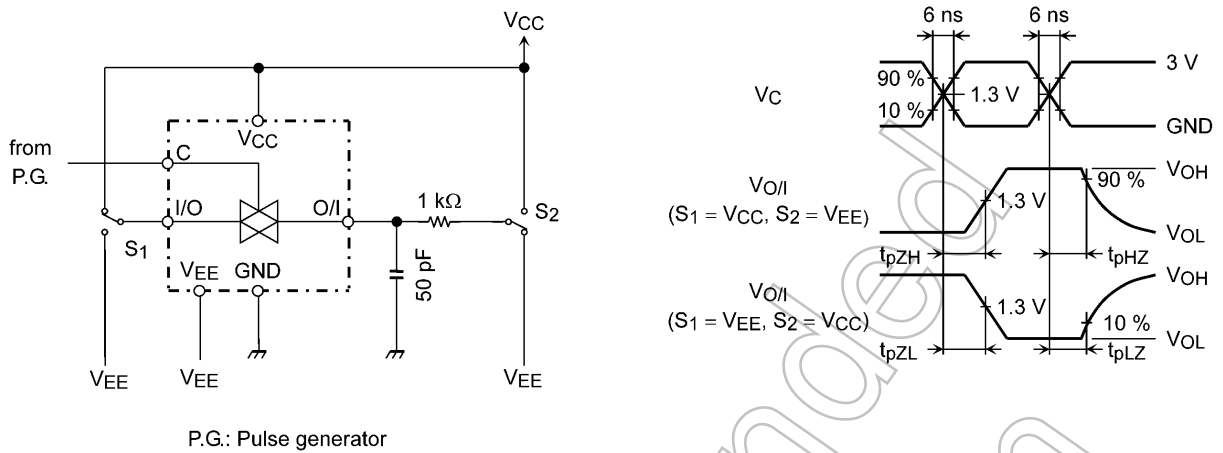

Figure 1 t_{pLZ} , t_{pHZ} , t_{pZL} , t_{pZH}

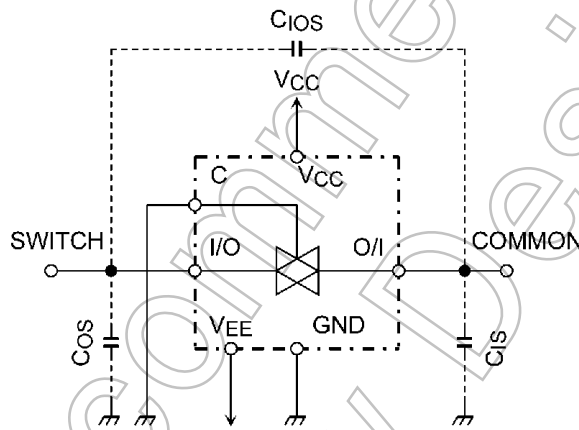

Figure 2 C_{10S} , C_{1S} , C_{0S}

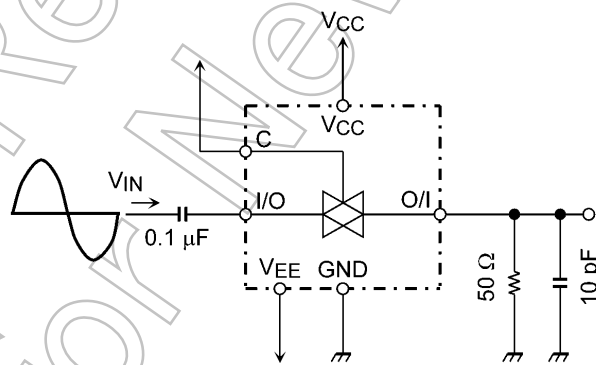

Figure 3 Frequency Response

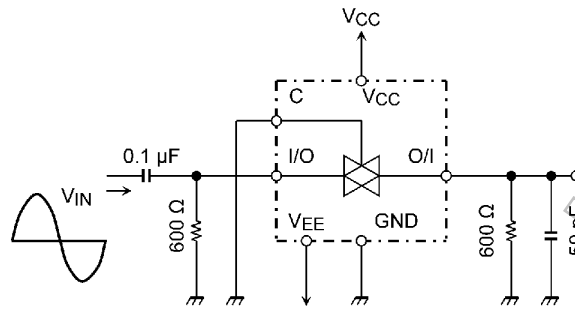
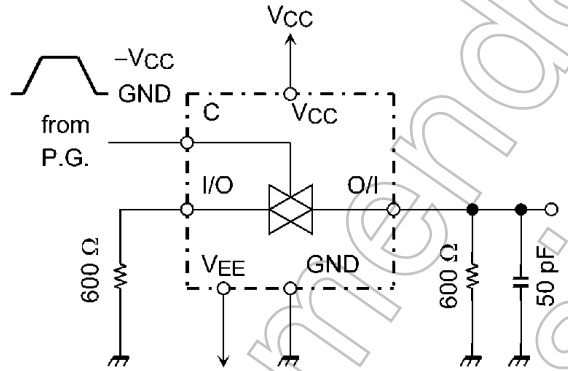

Figure 4 Feedthrough Attenuation



P.G: Pulse generator

Figure 5 Cross Talk (control input to output signal)

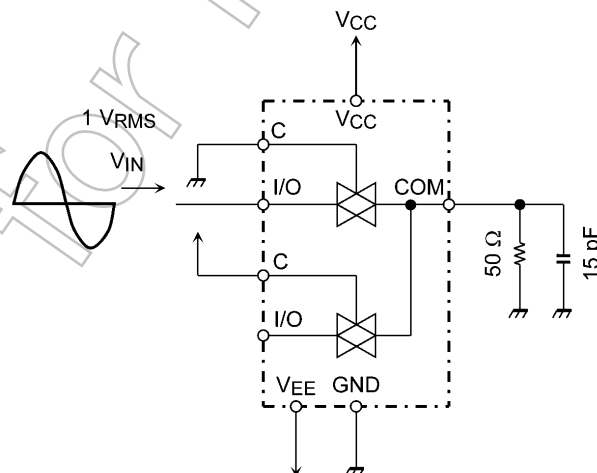
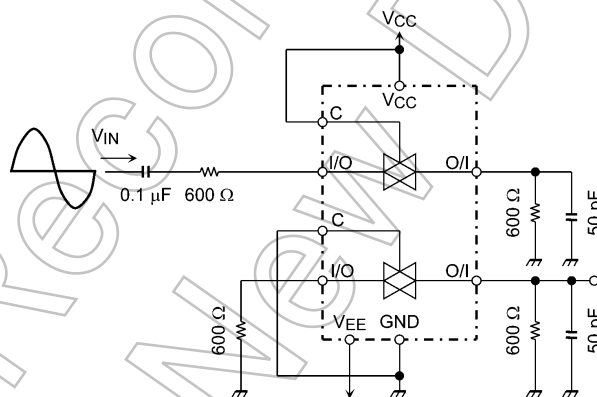
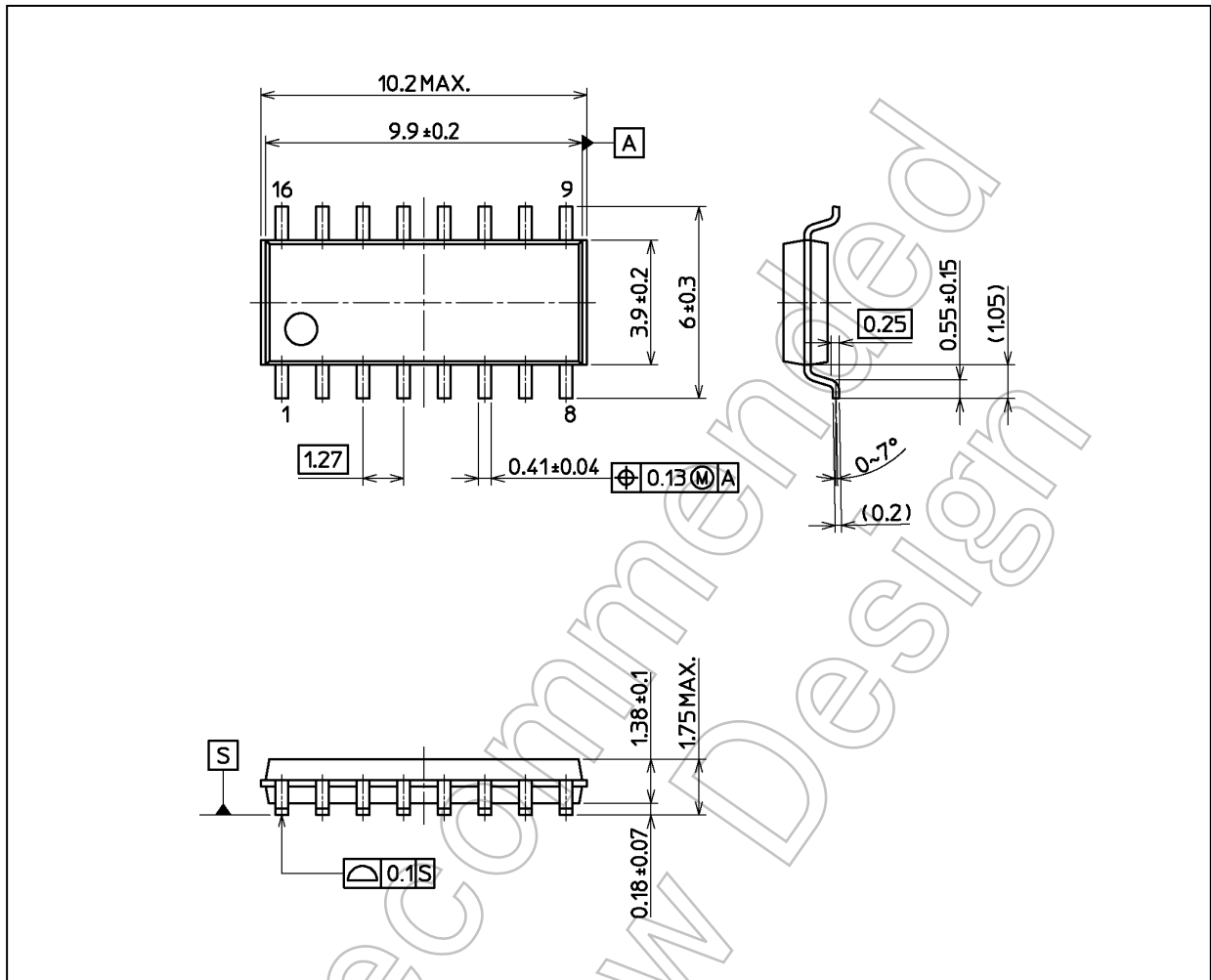

Figure 6 Cross Talk (between any two switches)

Package Dimensions

Unit: mm



Weight: 0.15 g (typ.)

Package Name(s)
Nickname: SOIC16

RESTRICTIONS ON PRODUCT USE

Toshiba Corporation and its subsidiaries and affiliates are collectively referred to as "TOSHIBA".

Hardware, software and systems described in this document are collectively referred to as "Product".

- TOSHIBA reserves the right to make changes to the information in this document and related Product without notice.
- This document and any information herein may not be reproduced without prior written permission from TOSHIBA. Even with TOSHIBA's written permission, reproduction is permissible only if reproduction is without alteration/omission.
- Though TOSHIBA works continually to improve Product's quality and reliability, Product can malfunction or fail. Customers are responsible for complying with safety standards and for providing adequate designs and safeguards for their hardware, software and systems which minimize risk and avoid situations in which a malfunction or failure of Product could cause loss of human life, bodily injury or damage to property, including data loss or corruption. Before customers use the Product, create designs including the Product, or incorporate the Product into their own applications, customers must also refer to and comply with (a) the latest versions of all relevant TOSHIBA information, including without limitation, this document, the specifications, the data sheets and application notes for Product and the precautions and conditions set forth in the "TOSHIBA Semiconductor Reliability Handbook" and (b) the instructions for the application with which the Product will be used with or for. Customers are solely responsible for all aspects of their own product design or applications, including but not limited to (a) determining the appropriateness of the use of this Product in such design or applications; (b) evaluating and determining the applicability of any information contained in this document, or in charts, diagrams, programs, algorithms, sample application circuits, or any other referenced documents; and (c) validating all operating parameters for such designs and applications.
TOSHIBA ASSUMES NO LIABILITY FOR CUSTOMERS' PRODUCT DESIGN OR APPLICATIONS.

- **PRODUCT IS NEITHER INTENDED NOR WARRANTED FOR USE IN EQUIPMENTS OR SYSTEMS THAT REQUIRE EXTRAORDINARILY HIGH LEVELS OF QUALITY AND/OR RELIABILITY, AND/OR A MALFUNCTION OR FAILURE OF WHICH MAY CAUSE LOSS OF HUMAN LIFE, BODILY INJURY, SERIOUS PROPERTY DAMAGE AND/OR SERIOUS PUBLIC IMPACT ("UNINTENDED USE").**

Except for specific applications as expressly stated in this document, Unintended Use includes, without limitation, equipment used in nuclear facilities, equipment used in the aerospace industry, lifesaving and/or life supporting medical equipment, equipment used for automobiles, trains, ships and other transportation, traffic signaling equipment, equipment used to control combustions or explosions, safety devices, elevators and escalators, and devices related to power plant.

IF YOU USE PRODUCT FOR UNINTENDED USE, TOSHIBA ASSUMES NO LIABILITY FOR PRODUCT.

For details, please contact your TOSHIBA sales representative or contact us via our website.

- Do not disassemble, analyze, reverse-engineer, alter, modify, translate or copy Product, whether in whole or in part.
- Product shall not be used for or incorporated into any products or systems whose manufacture, use, or sale is prohibited under any applicable laws or regulations.
- The information contained herein is presented only as guidance for Product use. No responsibility is assumed by TOSHIBA for any infringement of patents or any other intellectual property rights of third parties that may result from the use of Product. No license to any intellectual property right is granted by this document, whether express or implied, by estoppel or otherwise.
- **ABSENT A WRITTEN SIGNED AGREEMENT, EXCEPT AS PROVIDED IN THE RELEVANT TERMS AND CONDITIONS OF SALE FOR PRODUCT, AND TO THE MAXIMUM EXTENT ALLOWABLE BY LAW, TOSHIBA (1) ASSUMES NO LIABILITY WHATSOEVER, INCLUDING WITHOUT LIMITATION, INDIRECT, CONSEQUENTIAL, SPECIAL, OR INCIDENTAL DAMAGES OR LOSS, INCLUDING WITHOUT LIMITATION, LOSS OF PROFITS, LOSS OF OPPORTUNITIES, BUSINESS INTERRUPTION AND LOSS OF DATA, AND (2) DISCLAIMS ANY AND ALL EXPRESS OR IMPLIED WARRANTIES AND CONDITIONS RELATED TO SALE, USE OF PRODUCT, OR INFORMATION, INCLUDING WARRANTIES OR CONDITIONS OF MERCHANTABILITY, FITNESS FOR A PARTICULAR PURPOSE, ACCURACY OF INFORMATION, OR NONINFRINGEMENT.**
- Do not use or otherwise make available Product or related software or technology for any military purposes, including without limitation, for the design, development, use, stockpiling or manufacturing of nuclear, chemical, or biological weapons or missile technology products (mass destruction weapons). Product and related software and technology may be controlled under the applicable export laws and regulations including, without limitation, the Japanese Foreign Exchange and Foreign Trade Law and the U.S. Export Administration Regulations. Export and re-export of Product or related software or technology are strictly prohibited except in compliance with all applicable export laws and regulations.
- Please contact your TOSHIBA sales representative for details as to environmental matters such as the RoHS compatibility of Product. Please use Product in compliance with all applicable laws and regulations that regulate the inclusion or use of controlled substances, including without limitation, the EU RoHS Directive. **TOSHIBA ASSUMES NO LIABILITY FOR DAMAGES OR LOSSES OCCURRING AS A RESULT OF NONCOMPLIANCE WITH APPLICABLE LAWS AND REGULATIONS.**