

## TC78S121FTG/FNG Usage considerations

### **Summary**

The TC78S121 is a two-phase bipolar 2ch stepping motor driver using a PWM chopper.  
Fabricated with the BiCD process, rating is 40 V/2.0A.

**Contents**

Summary..... 1

Contents..... 2

1. Power supply voltage ..... 4

    1.1. Power supply voltage and usage range..... 4

    1.2. Power supply sequence ..... 4

2. Output current ..... 4

3. Control input..... 4

4. PWM control..... 5

5. Mixed Decay Mode / zero point detection operation ..... 7

6. Switching characteristics ..... 8

7. Function explanation ..... 8

    7.1. Function Table for Motor Drive Mode Selection..... 8

    7.2. Input Signal Function (In Stepping Motor Mode) ..... 9

    7.3. D\_TBLANK Function (DC Motor MODE only) ..... 9

    7.4. Decay Switching Function (Stepping Motor MODE only) ..... 9

    7.5. Control Signal Functions in Brushed DC Motor Mode ..... 10

    7.6. SLEEP Function ..... 10

    7.7. ALERT Function ..... 11

8. Application circuit (Example) ..... 12

9. Power consumption of the IC..... 16

10. Power dissipation ..... 17

11. Board dimensions..... 18

    11.1. Input / Main part (FNG: HTSSOP48) ..... 18

    11.2. Input / Main part (FTG: QFN48) ..... 19

12. Example of reference foot pattern..... 20

Notes on Contents..... 21

IC Usage Considerations..... 21

    Notes on handling of ICs ..... 21

    Points to remember on handling of ICs ..... 22

RESTRICTIONS ON PRODUCT USE ..... 23

**Contents of figures**

Figure 1.1	Power supply voltage and usage range .....	4
Figure 4.1	OSCM oscillation frequency .....	5
Figure 4.2	Chopping frequency (100 kHz) .....	6
Figure 4.3	Chopping frequency (50 kHz) .....	6
Figure 5.1	Mixed Decay waveform .....	7
Figure 6.1	Switching characteristics .....	8
Figure 8.1	Example of application circuit .....	12
Figure 8.2	Dead band time of ISD .....	15
Figure 10.1	Power dissipation .....	17
Figure 11.1	Input / Main part (FNG: HTSSOP48) .....	18
Figure 11.2	Input / Main part (FTG: QFN48) .....	19
Figure 12.1	QFN48 foot pattern .....	20
Figure 12.2	HTSSOP48 foot pattern .....	20

**Contents of tables**

Table 6.1	Switching characteristics .....	8
Table 8.1	Recommended capacitor values for power supply terminal .....	13
Table 8.2	Recommended resistance values for current detection .....	13
Table 8.3	Recommended resistance for monitor terminal .....	14

## 1. Power supply voltage

### 1.1. Power supply voltage and usage range

In using the TC78S121, the voltage should be applied to the terminals of VM, VREFA, and VREFB. The maximum rating of VM supply voltage is 40 V. Usage range of the power supply voltage is 8 to 38 V.

The maximum rating of VREF voltage is 5 V. Usage range of the voltage is 0 to 3.6 V.

As for the voltage of VREF, the voltage of the internal regulator of the IC (VCC) can be also used. (However, if the current is pulled up exceeding the capability of the internal regulator, the regulation of VCC may not be kept. When the voltage of VREF is applied by dividing the voltage of VCC, the total of the voltage-dividing resistance should not be less than 10 k $\Omega$ .)

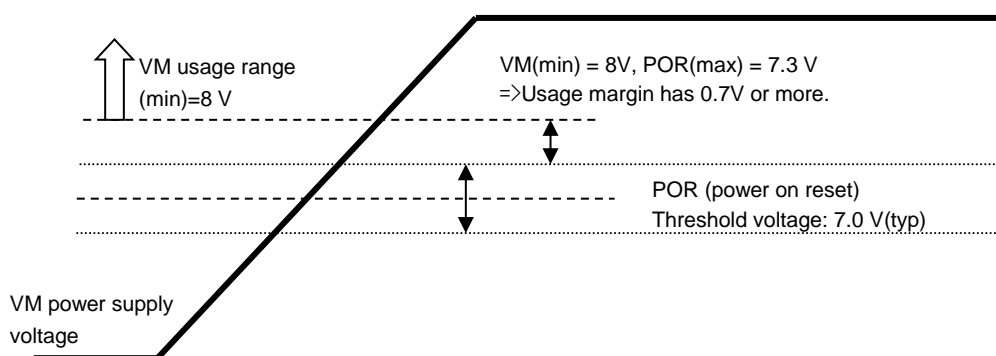

Figure 1.1 Power supply voltage and usage range

### 1.2. Power supply sequence

There are no special procedures of inputting a power supply and shutdown because the TC78S121 incorporates the power on reset (POR). However, under the unstable state of inputting the power supply (VM) and shutdown, it is recommended to turn off the motor operation. Please operate the motor by switching the input signal after the power supply becomes in the stable state.

## 2. Output current

Motor usage current should be 2.0 A or less. The maximum current of the actual usage is limited depending on the usage conditions (the ambient temperature, the wiring pattern of the board, the radiation path, and the exciting design). Configure the most appropriate current value after calculating the heat and evaluating the board under the operating environment.

## 3. Control input

When the logic input signal is inputted under the condition that the voltage of VM is not supplied, the electromotive force by inputting signal is not generated. However, configure the input signal low level before the power supply is applied by referring to the description of the “1.2. Power supply sequence”.

**4. PWM control**

The TC78S121 can adjust the internal oscillation frequency (fOSCM) and the chopping frequency (fchop) with the constant number of the external parts connecting to OSCM terminal.

- The OSCM oscillation frequency (fOSCM) and the chopping frequency (fchop) are as follows;

Chopping [kHz]	C [pF]	R [kΩ]
150	150	180
140	180	100
130	180	150
120	220	100
110	180	220
100	270	120
90	330	68
80	330	130
70	390	130
60	470	120
50	560	180
40	820	68

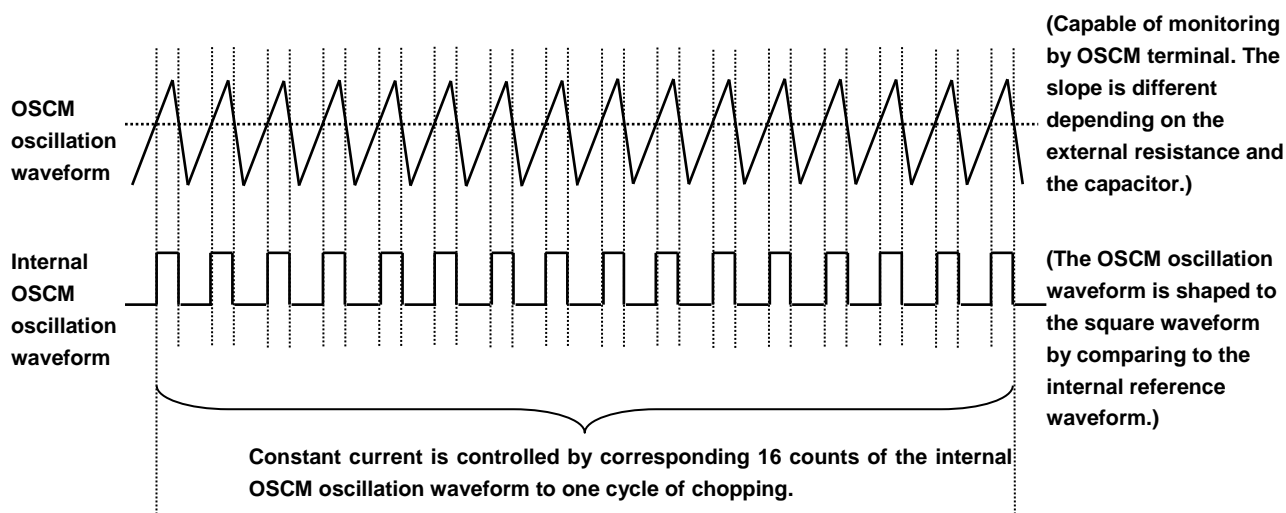

**Figure 4.1 OSCM oscillation frequency**

When the chopping frequency is increased, the motor can rotate faster because the following capability of the current steps increases. However, switching loss and heat increase may occur because the number of switching of output MOSFET is larger than the case of low frequency of the chopping.

(Example 1) Chopping frequency ( $f_{chop}$ ) = 100 kHz

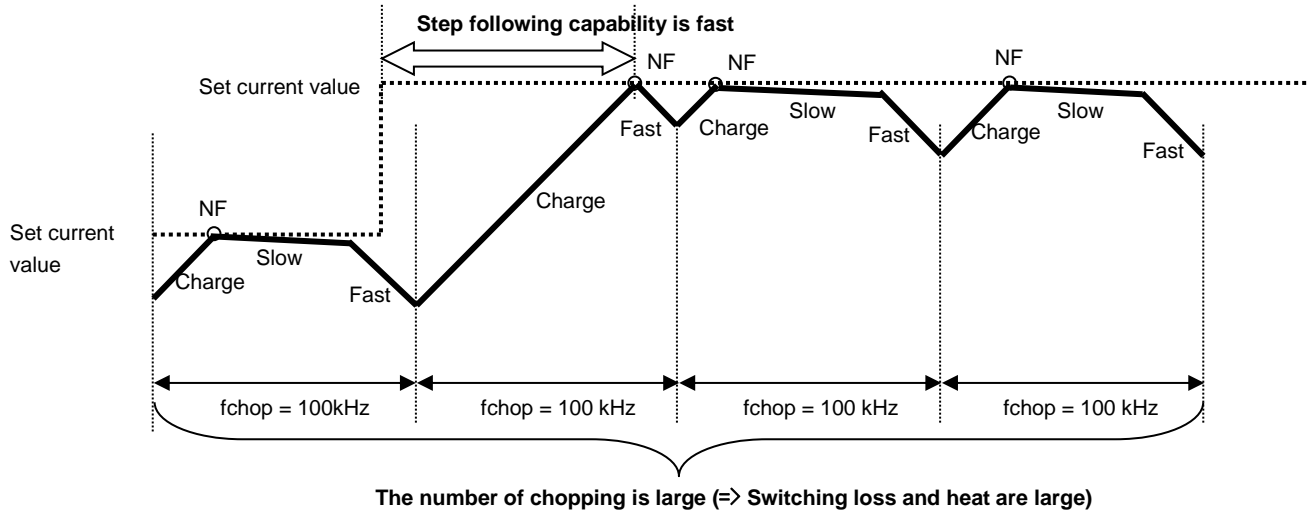

**Figure 4.2 Chopping frequency (100 kHz)**

(Example 2) Chopping frequency ( $f_{chop}$ ) = 50 kHz

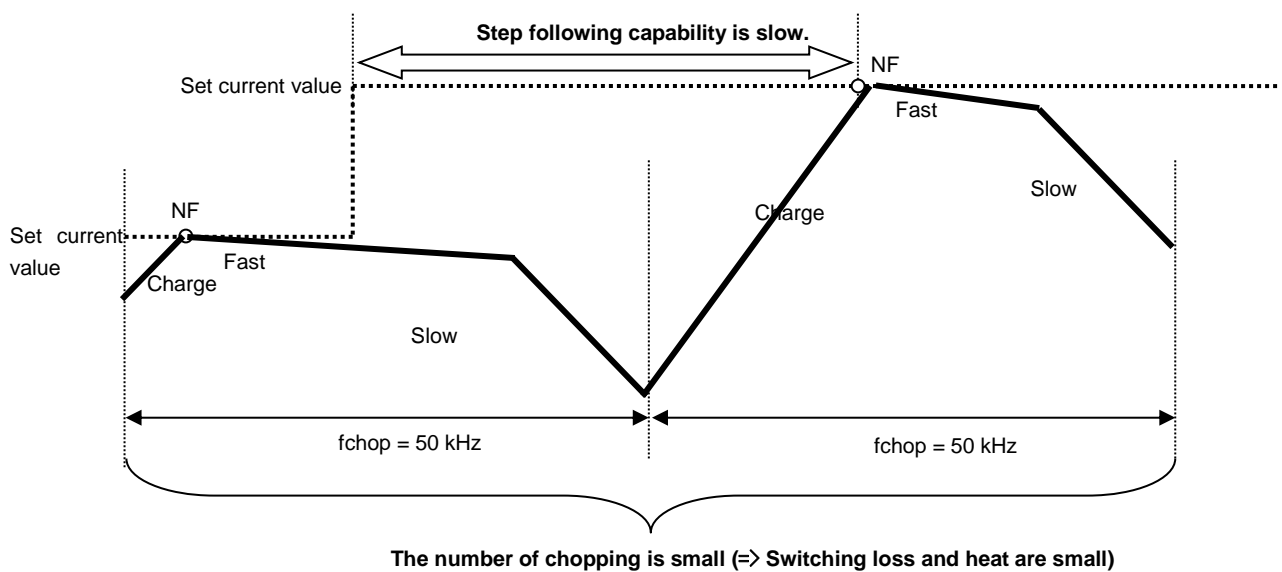
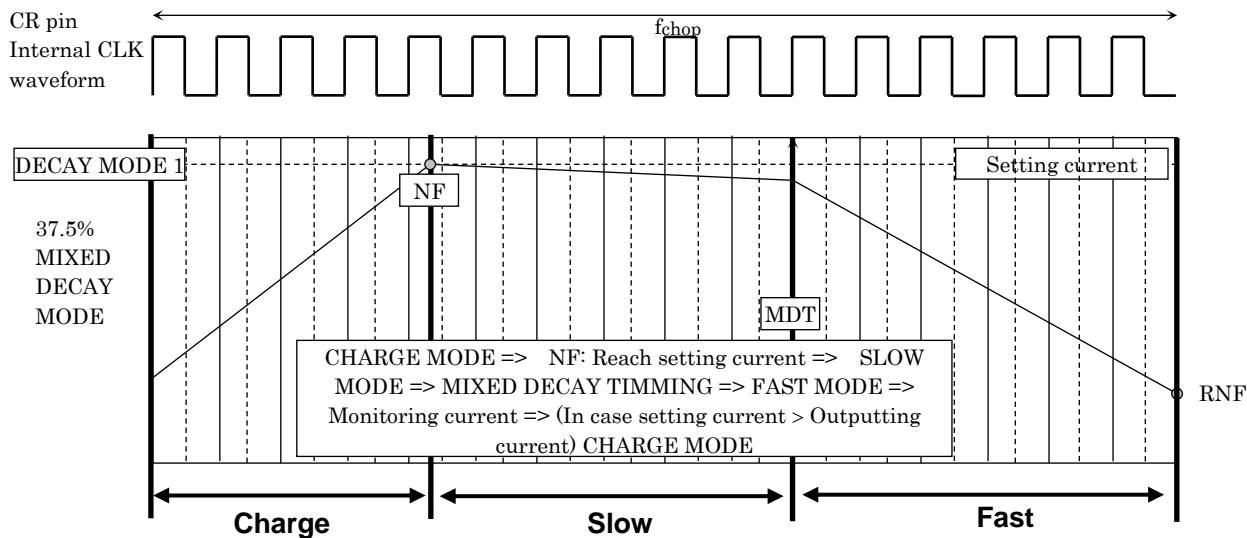

**Figure 4.3 Chopping frequency (50 kHz)**

Generally, it is recommended to configure the frequency in the range of 50 kHz to 100 kHz on the basis of 70 kHz.

**5. Mixed Decay Mode / zero point detection operation**

In the case of the constant current control, a period of drawing current (Fast) is fixed to  $OSCM=6CLK$ .



**Figure 5.1 Mixed Decay waveform**

## 6. Switching characteristics

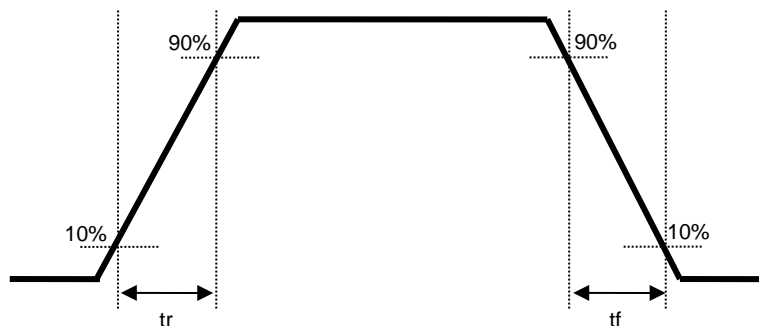

**Figure 6.1** Switching characteristics

**Table 6.1** Switching characteristics

$T_a = 25^\circ\text{C}$ ,  $V_M = 24\text{ V}$ , No load

Item	Typ.	Unit
tr	120	ns
tf	70	ns

## 7. Function explanation

### 7.1. Function Table for Motor Drive Mode Selection

Motor drive modes can be selected depending on the type of motors to be driven.

The configuration of H-bridge drivers and control category are changed according to the selected mode.

There is basically no need to change drive modes during motor operation. Thus, the TC78S121 does not support dynamic mode switching.

Changing the settings of these pins changes the functions and timing of control pins.

The setting of mode select pins must not be changed after the TC78S121 is powered on.

Mode 0	Mode 1	Mode 2	Drive Mode
H	H	H	Stepping Motor (S) × 2
L	H	H	DC Motor (L) (Combination) × 2
H	L	H	Stepping Motor (L) (Combination) × 1
L	L	H	DC Motor (S) × 4
H	H	L	DC Motor (L) (Combination) × 1 + Stepping Motor (S)
L	H	L	DC Motor (S) × 2 + Stepping Motor (S)
H	L	L	Inhibited (For Toshiba testing only)
L	L	L	Standby mode

- **Stepping Motor Mode**

This mode is used to drive stepping motors.



The tBLANK time is specified as a fixed analog value (about 550 ns). Each motor is controlled via three logic control inputs, PHASE (current direction) and IN\_X1/2, and via the Vref input for constant-current control.

- **Brushed DC Motor Mode**

This mode is used to drive brushed DC motors. The tBLANK time can be specified as a fixed analog value, or as four OSC cycles in digital tBLANK mode, where OSC is a reference signal for chopper circuit. When DC motors are driven under PWM control, a discharge current spike can occur due to a varistor. To prevent this current spike from erroneously tripping the constant-current sensor, the constant-current sensor is digitally blanked for a period of time that is determined by tBLANK, which is derived from the OSC signal. Using this blanking function enables constant-current limiter control, as well as external PWM control. An over-current can be observed only during blank times.

- **Combination Mode**

The Combination mode, such as DC Motor (L) and Stepping Motor (L) modes, can be selected when two units of H-bridges with the same characteristics are operated in parallel. In this mode, the actual ON-resistance is reduced by half while the current capability is doubled. (Specifications actually include the thermal capacitance as well. See electrical characteristics for more details.) To use this mode, the power supply, ground, and output pins that have identical names should be shorted together on the board. At the same time, the wirings of a board should be routed to balance the impedance at each pin. Otherwise, the shorted pins may experience a current imbalance and more current may flow into either one of them than the other.

**7.2. Input Signal Function (In Stepping Motor Mode)**

Input			Output		
PHASE_A PHASE_B	IN_X2	IN_X1	OUT_X+	OUT_X-	IOUT
H	H	H	H	L	100 %
	H	L	H	L	71 %
	L	H	H	L	38 %
	L	L	Output OFF	Output OFF	0 %
L	H	H	L	H	-100 %
	H	L	L	H	-71 %
	L	H	L	H	-38 %
	L	L	Output OFF	Output OFF	0 %

**7.3. D\_TBLANK Function (DC Motor MODE only)**

D_TBLANK_AB D_TBLANK_CD	Motor Drive Mode
L	OFF: Digital Blanking Time = OSC × 0
H	ON: Digital Blanking Time = OSC × 4

\*: If it is set to "L", only analog tBLANK width can be available.

**7.4. Decay Switching Function (Stepping Motor MODE only)**

D_TBLANK_AB D_TBLANK_CD	Constant current control mode
L	Mixed Decay:37.5 % fixed
H	Mixed Decay:12.5 % ( During the current decay is 37.5 %)

**7.5. Control Signal Functions in Brushed DC Motor Mode**

Control Input			State of the Output Stage		
IN_X1	IN_X2	PHASE_X	OUT_X+	OUT_X-	Mode
H	H	H	L	L	Short brake
		L			
L	H	H	L	H	Forward/reverse
		L	L	L	Short brake
H	L	H	H	L	Reverse/forward
		L	L	L	Short brake
L	L	H	OFF (Hi-Z)	OFF (Hi-Z)	Stop
		L			

\*: "X" means the ellipsis of A / B / C / D of each Ch. (IN\_X1, IN\_X2, and PHASE\_X)

- **External PWM Control Function**

The motor speed can be controlled by applying 0 V and 5 V (higher than TTL level) PWM signals to the PWM pin.

In PWM mode, the PWM chopper circuit alternates between on and short brake.

When the PWM speed control is not required, the PWM pin (short brake pin) should be held High.

When the constant-current limiter is used, the TC78S121 enters 37.5 % Mixed Decay mode after an output current reaches the predefined current value. Since the dead band time (typ.300 ns) is internally inserted to prevent a shoot-through current eliminating, the special arrangement is not required.

The short brake function is disabled in Stepping Motor mode (Large or Small).

Stepping motors can also be driven in Brushed DC motor mode.

To perform such operation, the short brake function should not be used and the D\_TBLANK pin should be set Low.

At the same time, input signal functions should also be confirmed.

**7.6. SLEEP Function**

In the SLEEP pin, it is possible to control the low power consumption mode (VCC OFF) and the normal operation mode (VCC ON).

When SLEEP pin is Low, VCC regulator is turned OFF, completely logic will stop.

After SLEEP pin is set to High, it can return to the normal operation mode in 1ms.

SLEEP	Function
L	low power consumption mode (VCC OFF)
H	normal operation mode (VCC ON)

### 7.7. ALERT Function

The ALERT pin outputs "Low" level when an error occasion (TSD/ISD) is detected.

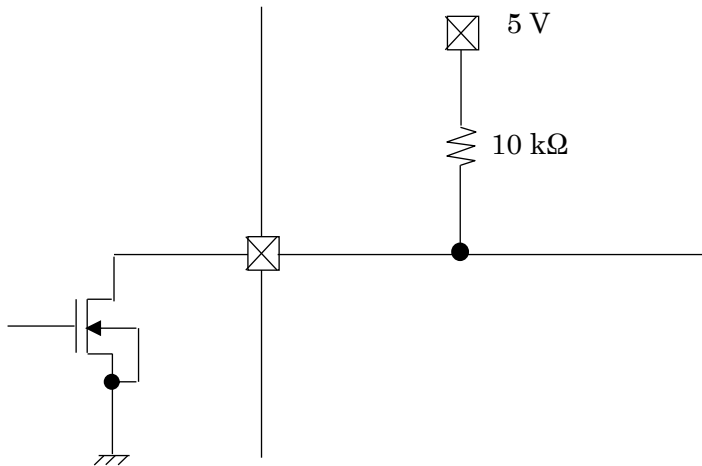

The ALERT is an open drain output pin. When the output pin is pulled up to the VCC with resistance, the Low is output (MOSFET ON) at the Reset, and the High (internal Hi-Z) is output at the non-reset.

Please connect with pull-up to the VCC.

8. Application circuit (Example)

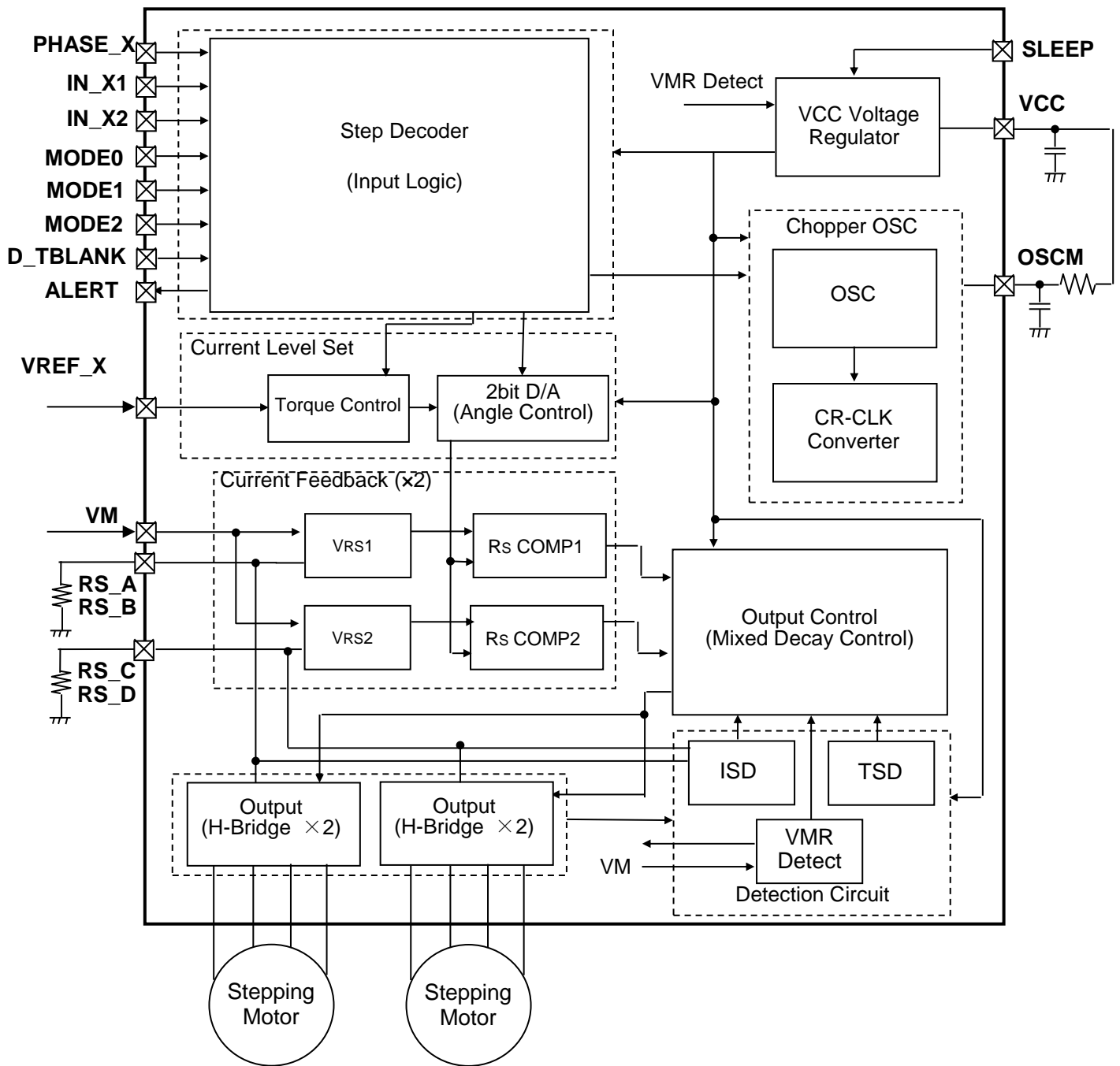

The application circuits shown in this document are provided for reference purposes only. Thorough evaluation is required, especially at the mass-production design stage.

Figure 8.1 Example of application circuit

**(1) Capacitor for power supply terminal**

To stabilize the power supply voltage of the IC and reduce the noise, connect the appropriate capacitor to each terminal. It is recommended to connect the capacitor as close to the IC as possible. Especially, by connecting the ceramic capacitor near the IC, the change of the power supply at the high frequency range and the noise can be reduced.

**Table 8.1 Recommended capacitor values for power supply terminal**

Item	Parts	Typ.	Recommended range
VM-GND	Electrolytic capacitor	100 $\mu$ F	47 to 100 $\mu$ F
	Ceramic capacitor	0.1 $\mu$ F	0.01 to 1 $\mu$ F
VCC-GND	Ceramic / Electrolytic capacitor	1 $\mu$ F	1 $\mu$ F
(VREF-GND)	Ceramic capacitor	0.1 $\mu$ F	0.01 to 1 $\mu$ F

\* VREF-GND: Connect the capacitor in necessary depending on the usage environment.

\* It is possible to use the capacitor, which is not the recommended capacitor, depending on the motor load condition and the design pattern of the board.

**(2) Resistance of current detection**

This IC configures the threshold of the constant current detection by connecting the resistance of current detection between VM and RS terminals. The detection resistance is recommended to connect near the IC. (The motor can be controlled with the accurate current because the influence of the wire resistance of the board can be reduced.)

**Table 8.2 Recommended resistance values for current detection**

Item	Parts	Typ.	Recommended range
VM-RS	Chip / Lead resistance	0.22 $\Omega$ (0 to 2.0 A)	0.22 to 1.0 $\Omega$

The relation equation of the threshold of the constant current detection, Vref voltage, and the resistance of RS detection is as follows:

$$I_{out(max)} = V_{ref}(\text{gain}) \times \frac{V_{ref}(V)}{R_{RS}(\Omega)}$$

Vref(gain): Vref decay ratio is 1 / 5.0(typ.).

As for the resistance of current detection, the constant number which is out of recommended range can be adopted. In this case, please pay attentions to the followings when the used resistance is high and low.

- When the detection resistance is low, the difference voltage between VM and RS comparing to the internal reference voltage becomes small. So, the current may be largely different from the configured current value.
- When the detection resistance is high, the power applied to the detection resistance increases in motor operation ( $P=I^2 \times R$ ). So, in case the same current flows as the case of low resistance, the power dissipation should be larger.

**(3) Resistance for monitor terminal**

This IC has open-drain terminals of ALERT. When internal MOSFET is turned off, it is high impedance as a terminal level. In order to operate the IC with accurate high and low levels, connect the pull-up resistance to the power supply of 3.3 V or 5 V in using.

**Table 8.3 Recommended resistance for monitor terminal**

Item	Parts	Typ.	Recommended range
ALERT (3.3V or VCC)	Chip / Lead resistance	10 k $\Omega$	10 to 100 k $\Omega$

**(4) Wiring pattern for power supply and GND**

Since large current may flow in VM, RS, and GND pattern especially, design the appropriate wiring pattern to avoid the influence of wiring impedance. It is very important for surface mounting package to radiate the heat from the heat sink of the back side of the IC to the GND. So, design the pattern by considering the heat design.

**(5) Fuse**

Use an appropriate power supply fuse for the power supply line to ensure that a large current does not continuously flow in the case of over-current and/or IC failure.

The IC will fully break down when used under conditions that exceed its absolute maximum ratings, when the wiring is routed improperly or when an abnormal pulse noise occurs from the wiring or load, causing a large current to continuously flow and the breakdown can lead to smoke or ignition. To minimize the effects of the flow of a large current in the case of breakdown, appropriate settings, such as fuse capacity, fusing time and insertion circuit location, are required.

This IC incorporates over current detection circuit (ISD) that turns off the output of the IC when over current is detected in the IC. However, it does not necessarily protect ICs under all circumstances. If the Over current detection circuits operate against the over current, clear the over current status immediately. Depending on the method of use and usage conditions, such as exceeding absolute maximum ratings can cause the over current protection circuit to not operate properly or IC breakdown before operation. In addition, depending on the method of use and usage conditions, if over current continues to flow for a long time after operation, the IC may generate heat resulting in breakdown.

To avoid above IC destruction and malfunctions caused by noise, the over current detection circuit has a dead band time. So, it is concerned that the over current detection circuit may not operate depending on the output load conditions because of the dead band time. Therefore, in order to avoid continuing this abnormal state, use the fuse for the power supply line.

**(6) Abnormality detection function**

- Thermal shutdown circuit (TSD)  
When the junction temperature of the IC reaches the specified value, the internal detection circuit operates to turn off the output block. The dead band time is provided in the IC to avoid the malfunction caused by switching and so on. While TSD works, the operation of the IC is in the standby mode. To resume the shutdown circuit, apply the power supply again or configure the standby mode by DMODE terminal. TSD function works when the IC is heated abnormally. Use the IC with the appropriate environment not to operate the TSD function often.
- Over current protection (ISD)  
When the current, which exceeds the specified value, flows in the motor output, internal detection circuit operates and the operation of the output block is turned off. The dead band time is provided in the IC to avoid the malfunction caused by switching and so on. While ISD works, the operation of the IC is in the standby mode. To resume the ISD protection, apply the power supply again or configure the standby mode by DMODE terminal.

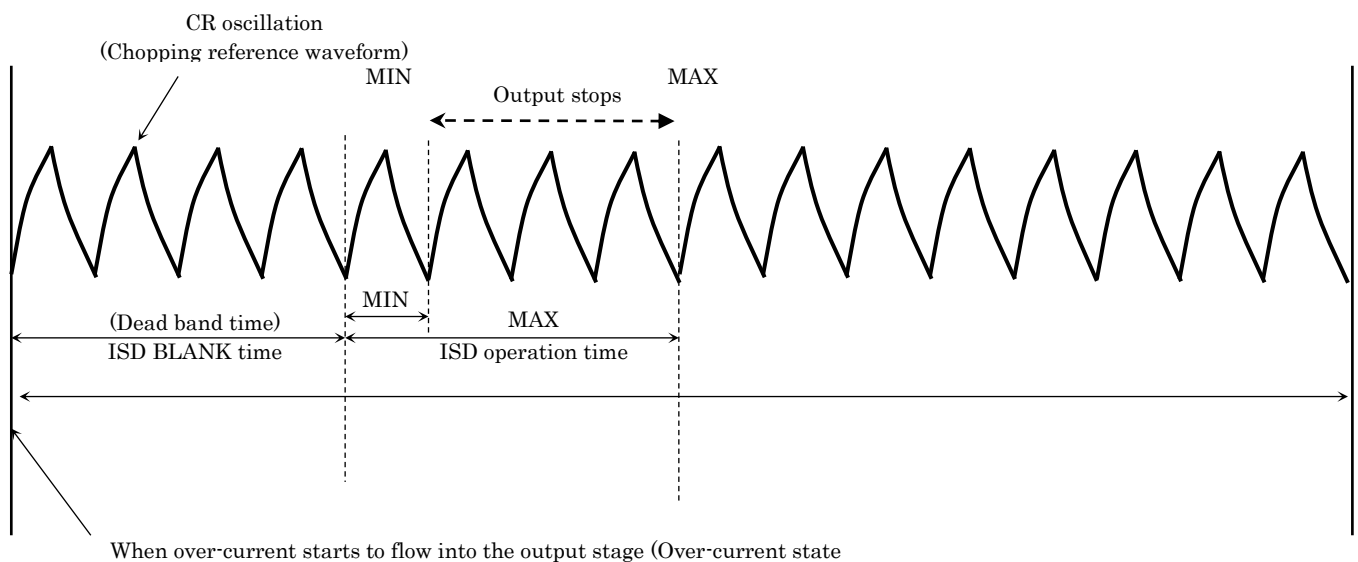
**Dead band time of ISD**

Timing charts may be simplified for explanatory purposes.

**Figure 8.2 Dead band time of ISD**

The over-current detection circuit has a dead band time to prevent erroneous detection of IRR or spike current at switching. The dead band time being synchronized with the frequency of the OSC for setting chopping frequency is expressed as follows.

Dead band time =  $4 \times \text{CR time}$

Time required to stop the output after over-current flows into the output stage is expressed as follows.

Minimum time:  $4 \times \text{CR time}$

Maximum time:  $8 \times \text{CR time}$

Note that the above-mentioned operating times are achieved only when over-current flows as it is expected. Depending on the timing of output control mode, the circuit may not be triggered.

Thus, to ensure safe operation, please insert a fuse in the motor power supply.

The capacity of the fuse is determined according to the usage conditions. Please select one whose capacity does not exceed the power dissipation for the IC to avoid any operating problems.

## 9. Power consumption of the IC

Power of the IC is consumed by the transistor of the output block and that of the logic block mainly.

$$P(\text{total}) = P(\text{out}) + P(\text{bias})$$

- Power consumption of the motor output block  
Power of the output block (P(out)) is consumed by MOSFET of upper and lower H-Bridge.

$$P(\text{out}) = \text{Number of H-Bridge} \times I_{\text{out}} (\text{A}) \times V_{\text{DS}} (\text{V}) = 2 (\text{ch}) \times I_{\text{out}} (\text{A}) \times I_{\text{out}} (\text{A}) \times R_{\text{on}} (\Omega) \dots \dots \dots (1)$$

When the current waveform of the motor output corresponds to the ideal waveform (2-phase excitation / square wave), average power of output block can be provided as follows;

When  $R_{\text{on}} = 0.6\Omega$ ,  $I_{\text{out}} (\text{peak: Max}) = 1.5 \text{ A}$ ,  $V_{\text{M}} = 24 \text{ V}$

$$P(\text{out}) = 2 (\text{ch}) \times 1.5 (\text{A}) \times 1.5 (\text{A}) \times 0.6(\Omega) \dots \dots \dots (2)$$

$$= 2.7 (\text{W})$$

When the maximum resolution capability of the TC78S121 (W1-2 phase, 4 steps) is configured by using  $\mu$ -stepping function, the average power is about 71% (=  $1/\sqrt{2}$ ) and P(out) is 1.35 (W).

- Power consumption of logic and IM systems.  
Power consumptions of logic and IM systems are calculated by separating the states (operating and stopping).

$$I (\text{IM3}) = 8.0 \text{ mA (typ.) : Operating}$$

$$I (\text{IM2}) = 3.5 \text{ mA (typ.) : Stopping}$$

Output system is connected to VM (24V). (Output system: Current consumed by the circuit connected to VM + Current consumed by switching output steps)

Power consumption is calculated as follows;

$$P(\text{bias}) = 24 (\text{V}) \times 0.008 (\text{A}) \dots \dots \dots (3)$$

$$= 0.192 (\text{W})$$

- Power consumption  
Total power consumption P(total) is calculated from the values of formula (2) and (3).

$$P(\text{total}) = P(\text{out}) + P(\text{bias}) = 2.7 + 0.192 = 2.892 (\text{W})$$

Standby mode is released. The power consumption in non-operation mode of the motor (waiting mode) is calculated as follows;

$$P = 24 (\text{V}) \times 0.0035 (\text{A}) = 0.0840 (\text{W})$$

In actual motor operation, the average current becomes lower than the calculated value because of transition time of the current steps and the ripple of the constant current PWM. Refer to the above equations, evaluate the heat design of the board by the actual board enough, and configure the appropriate margin.



### 10. Power dissipation

Relation equation of the ambient temperature ( $T_a$ ), junction temperature ( $T_j$ ), and the heat resistance ( $R_{th(j-a)}$ ) between junction temperature to ambient temperature is as follows;

$$T_j = T_a + P \times R_{th(j-a)}$$

(Example) When 4-layer mounting board ( $R_{th(j-a)} = 25^\circ\text{C/W}$ ),  $T_a = 25^\circ\text{C}$ ,  $P$  (total) = 2.892 W ( $I_{out} = 1.5$  A, 2-phase excitation)

$$T_j = 25 (\text{°C}) + 25 (\text{°C/W}) \times 2.892 (\text{W}) = 97.3^\circ\text{C}$$

(Reference) Relation between the power dissipation and the ambient temperature

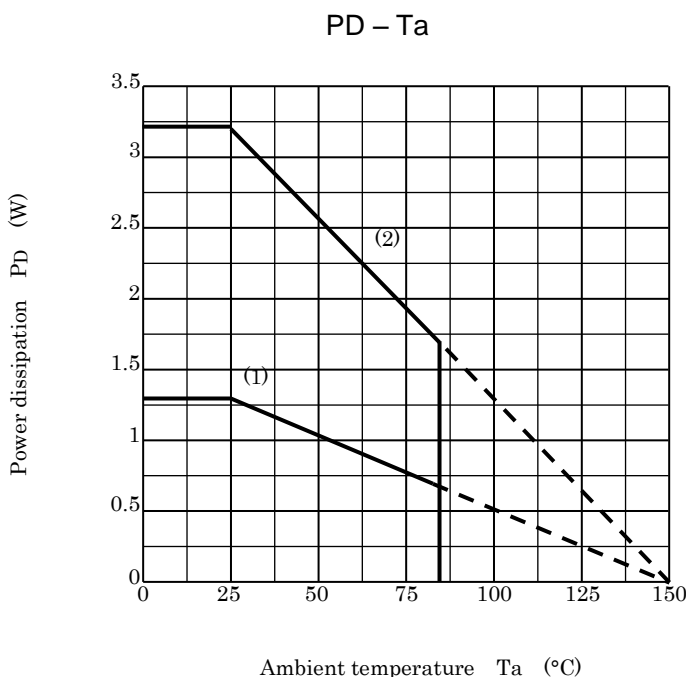

**Figure 10.1 Power dissipation**

- (1)  $R_{th(j-a)}$  IC only ( $113^\circ\text{C/W}$ )
- (2) When dedicated board is mounted (100 mm × 200 mm × 1.6 mm 2layer:  $37^\circ\text{C/W}$  (typ.))

\* Pay attention that  $T_a$ ,  $R_{th(j-a)}$ , and  $P$ (total) depend on the usage environment. When ambient temperature is high, the allowable power consumption decreases.

11. Board dimensions

11.1. Input / Main part (FNG: HTSSOP48)

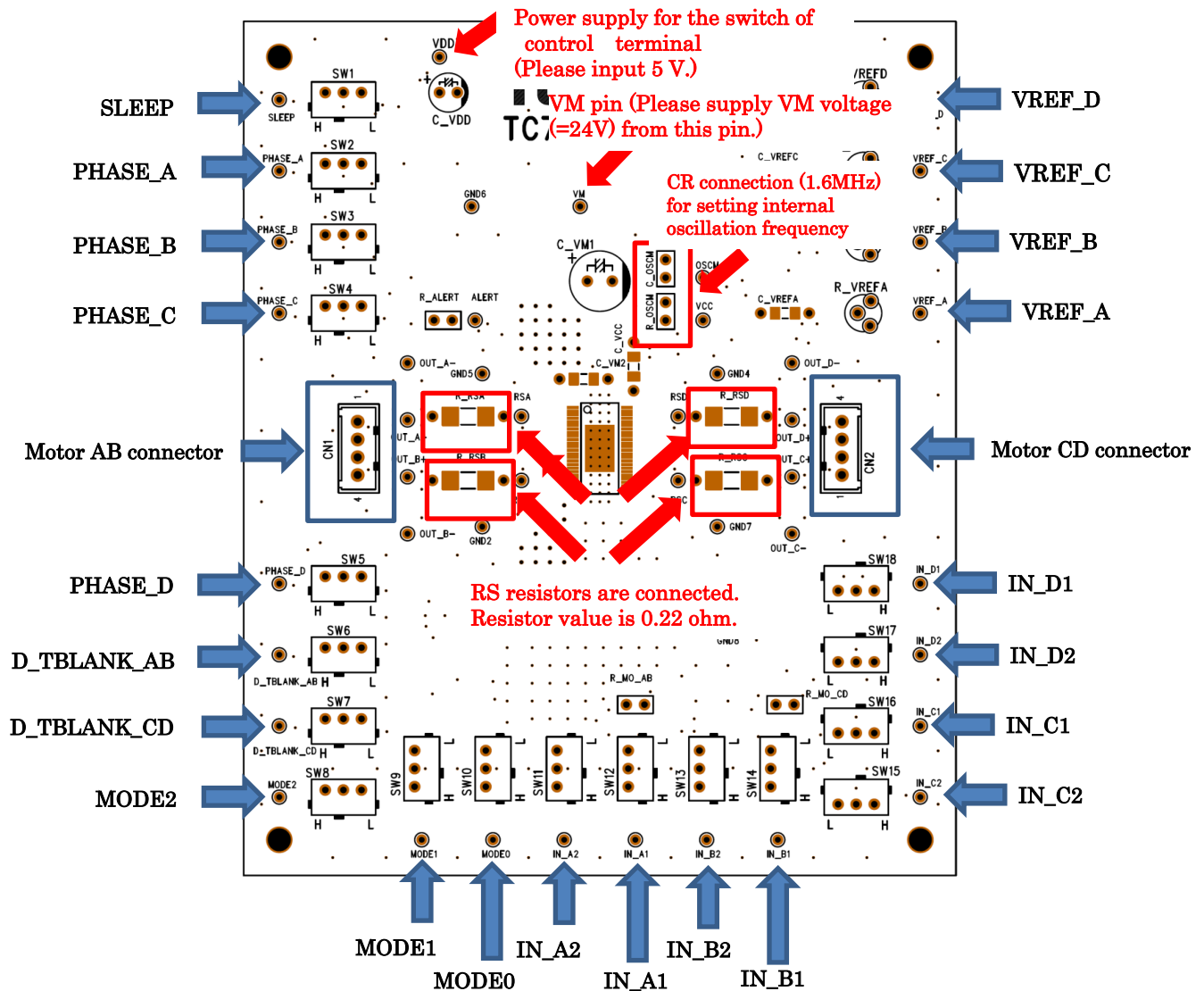
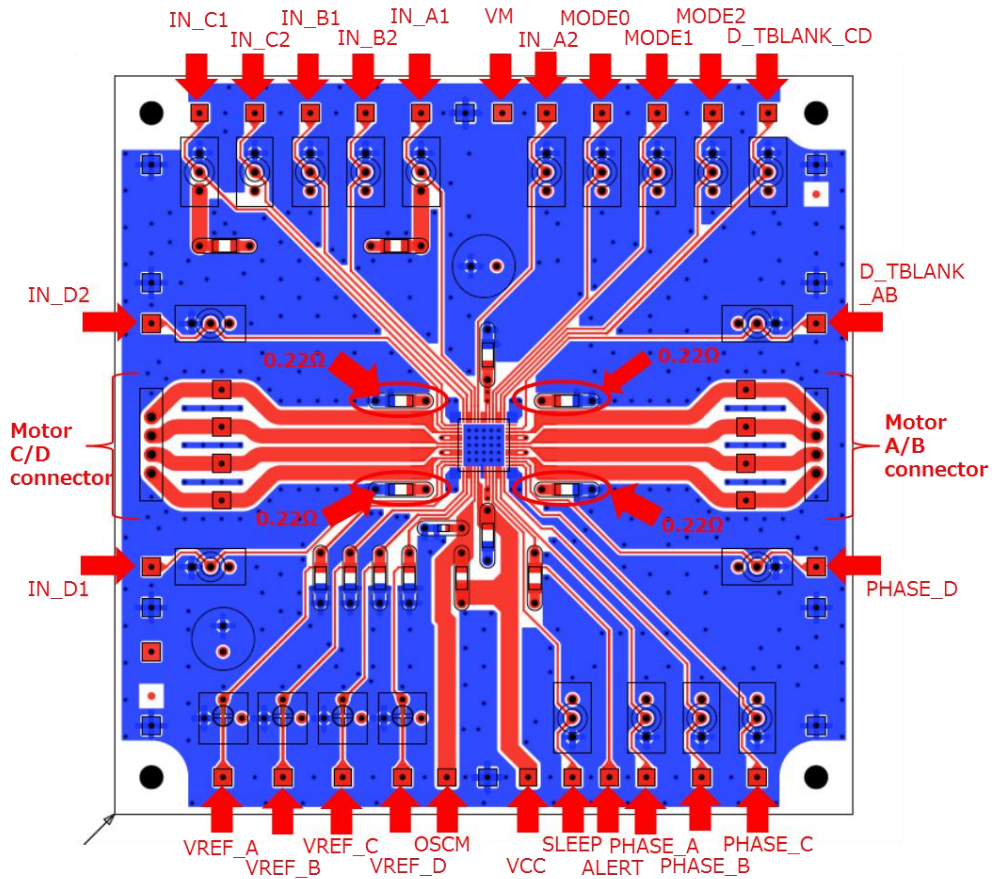

Figure 11.1 Input / Main part (FNG: HTSSOP48)

Input each power supply and control signal according to above figure.  
Connect each part referring to “8. Application circuit”

**11.2. Input / Main part (FTG: QFN48)**

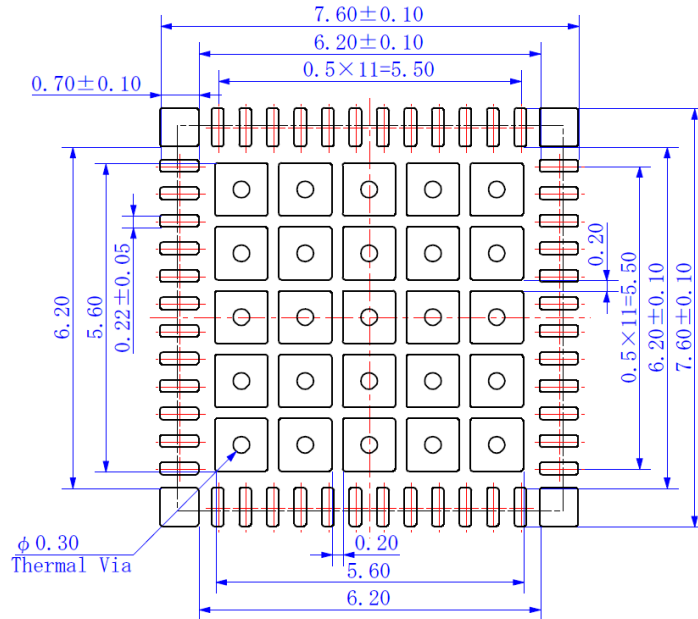

**Figure 11.2 Input / Main part (FTG: QFN48)**

Input each power supply and control signal according to above figure.  
 Connect each part referring to “8. Application circuit

**12. Example of reference foot pattern**

(1) QFN48 foot pattern (unit: mm)



**Figure 12.1 QFN48 foot pattern**

(2) HTSSOP48 foot pattern (unit: mm)

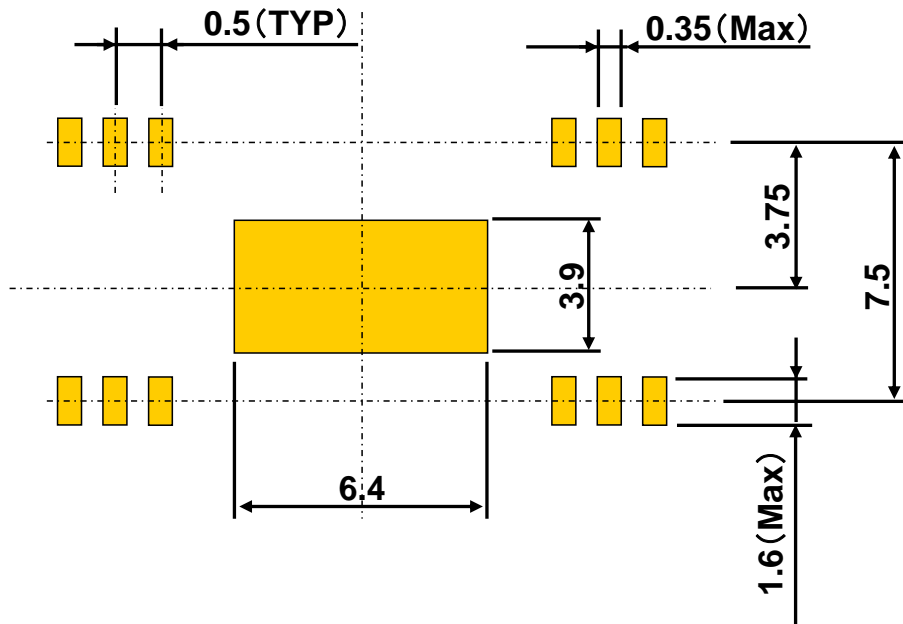

**Figure 12.2 HTSSOP48 foot pattern**

Toshiba does not guarantee the data for mass production. Please use the data as reference data for customer’s application.

Notes: In determining the size of mounting board, design the most appropriate pattern by considering the solder bridge, the solder connecting strength, the pattern accuracy in making board, the heat sink of leads, and the mounting accuracy of the IC board.

## Notes on Contents

1. Block Diagrams  
Some of the functional blocks, circuits, or constants in the block diagram may be omitted or simplified for explanatory purposes.
2. Equivalent Circuits  
The equivalent circuit diagrams may be simplified or some parts of them may be omitted for explanatory purposes.
3. Timing Charts  
Timing charts may be simplified for explanatory purposes.
4. Application Circuits  
The application circuits shown in this document are provided for reference purposes only. Thorough evaluation is required, especially at the mass-production design stage. Toshiba does not grant any license to any industrial property rights by providing these examples of application circuits.
5. Test Circuits  
Components in the test circuits are used only to obtain and confirm the device characteristics. These components and circuits are not guaranteed to prevent malfunction or failure from occurring in the application equipment.

## IC Usage Considerations

### Notes on handling of ICs

- (1) The absolute maximum ratings of a semiconductor device are a set of ratings that must not be exceeded, even for a moment. Do not exceed any of these ratings. Exceeding the rating(s) may cause device breakdown, damage or deterioration, and may result in injury by explosion or combustion.
- (2) Use an appropriate power supply fuse to ensure that a large current does not continuously flow in the case of overcurrent and/or IC failure. The IC will fully break down when used under conditions that exceed its absolute maximum ratings, when the wiring is routed improperly or when an abnormal pulse noise occurs from the wiring or load, causing a large current to continuously flow and the breakdown can lead to smoke or ignition. To minimize the effects of the flow of a large current in the case of breakdown, appropriate settings, such as fuse capacity, fusing time and insertion circuit location, are required.
- (3) If your design includes an inductive load such as a motor coil, incorporate a protection circuit into the design to prevent device malfunction or breakdown caused by the current resulting from the inrush current at power ON or the negative current resulting from the back electromotive force at power OFF. IC breakdown may cause injury, smoke or ignition. Use a stable power supply with ICs with built-in protection functions. If the power supply is unstable, the protection function may not operate, causing IC breakdown. IC breakdown may cause injury, smoke or ignition.
- (4) Do not insert devices in the wrong orientation or incorrectly. Make sure that the positive and negative terminals of power supplies are connected properly. Otherwise, the current or power consumption may exceed the absolute maximum rating, and exceeding the rating(s) may cause device breakdown, damage or deterioration, and may result in injury by explosion or combustion.  
In addition, do not use any device inserted in the wrong orientation or incorrectly to which current is applied even just once.
- (5) Carefully select external components (such as inputs and negative feedback capacitors) and load components (such as speakers), for example, power amp and regulator.  
If there is a large amount of leakage current such as from input or negative feedback condenser, the IC output DC voltage will increase. If this output voltage is connected to a speaker with low input withstand voltage, overcurrent or IC failure may cause smoke or ignition. (The overcurrent may cause smoke or ignition from the IC itself.) In particular, please pay attention when using a Bridge Tied Load (BTL) connection-type IC that inputs output DC voltage to a speaker directly.

**Points to remember on handling of ICs****(1) Overcurrent detection Circuit**

Overcurrent detection circuits (referred to as current limiter circuits) do not necessarily protect ICs under all circumstances. If the overcurrent detection circuits operate against the overcurrent, clear the overcurrent status immediately.

Depending on the method of use and usage conditions, exceeding absolute maximum ratings may cause the overcurrent detection circuit to operate improperly or IC breakdown may occur before operation. In addition, depending on the method of use and usage conditions, if overcurrent continues to flow for a long time after operation, the IC may generate heat resulting in breakdown.

**(2) Thermal Shutdown Circuit**

Thermal shutdown circuits do not necessarily protect ICs under all circumstances. If the thermal shutdown circuits operate against the over-temperature, clear the heat generation status immediately.

Depending on the method of use and usage conditions, exceeding absolute maximum ratings may cause the thermal shutdown circuit to operate improperly or IC breakdown to occur before operation.

**(3) Heat Radiation Design**

When using an IC with large current flow such as power amp, regulator or driver, design the device so that heat is appropriately radiated, in order not to exceed the specified junction temperature (T<sub>J</sub>) at any time or under any condition. These ICs generate heat even during normal use. An inadequate IC heat radiation design can lead to decrease in IC life, deterioration of IC characteristics or IC breakdown. In addition, when designing the device, take into consideration the effect of IC heat radiation with peripheral components.

**(4) Back-EMF**

When a motor rotates in the reverse direction, stops or slows abruptly, current flows back to the motor's power supply owing to the effect of back-EMF. If the current sink capability of the power supply is small, the device's motor power supply and output pins might be exposed to conditions beyond the absolute maximum ratings. To avoid this problem, take the effect of back-EMF into consideration in system design.

## RESTRICTIONS ON PRODUCT USE

- Toshiba Corporation, and its subsidiaries and affiliates (collectively "TOSHIBA"), reserve the right to make changes to the information in this document, and related hardware, software and systems (collectively "Product") without notice.
- This document and any information herein may not be reproduced without prior written permission from TOSHIBA. Even with TOSHIBA's written permission, reproduction is permissible only if reproduction is without alteration/omission.
- Though TOSHIBA works continually to improve Product's quality and reliability, Product can malfunction or fail. Customers are responsible for complying with safety standards and for providing adequate designs and safeguards for their hardware, software and systems which minimize risk and avoid situations in which a malfunction or failure of Product could cause loss of human life, bodily injury or damage to property, including data loss or corruption. Before customers use the Product, create designs including the Product, or incorporate the Product into their own applications, customers must also refer to and comply with (a) the latest versions of all relevant TOSHIBA information, including without limitation, this document, the specifications, the data sheets and application notes for Product and the precautions and conditions set forth in the "TOSHIBA Semiconductor Reliability Handbook" and (b) the instructions for the application with which the Product will be used with or for. Customers are solely responsible for all aspects of their own product design or applications, including but not limited to (a) determining the appropriateness of the use of this Product in such design or applications; (b) evaluating and determining the applicability of any information contained in this document, or in charts, diagrams, programs, algorithms, sample application circuits, or any other referenced documents; and (c) validating all operating parameters for such designs and applications. **TOSHIBA ASSUMES NO LIABILITY FOR CUSTOMERS' PRODUCT DESIGN OR APPLICATIONS.**
- **PRODUCT IS NEITHER INTENDED NOR WARRANTED FOR USE IN EQUIPMENTS OR SYSTEMS THAT REQUIRE EXTRAORDINARILY HIGH LEVELS OF QUALITY AND/OR RELIABILITY, AND/OR A MALFUNCTION OR FAILURE OF WHICH MAY CAUSE LOSS OF HUMAN LIFE, BODILY INJURY, SERIOUS PROPERTY DAMAGE AND/OR SERIOUS PUBLIC IMPACT ("UNINTENDED USE").** Except for specific applications as expressly stated in this document, Unintended Use includes, without limitation, equipment used in nuclear facilities, equipment used in the aerospace industry, medical equipment, equipment used for automobiles, trains, ships and other transportation, traffic signaling equipment, equipment used to control combustions or explosions, safety devices, elevators and escalators, devices related to electric power, and equipment used in finance-related fields. **IF YOU USE PRODUCT FOR UNINTENDED USE, TOSHIBA ASSUMES NO LIABILITY FOR PRODUCT.** For details, please contact your TOSHIBA sales representative.
- Do not disassemble, analyze, reverse-engineer, alter, modify, translate or copy Product, whether in whole or in part.
- Product shall not be used for or incorporated into any products or systems whose manufacture, use, or sale is prohibited under any applicable laws or regulations.
- The information contained herein is presented only as guidance for Product use. No responsibility is assumed by TOSHIBA for any infringement of patents or any other intellectual property rights of third parties that may result from the use of Product. No license to any intellectual property right is granted by this document, whether express or implied, by estoppel or otherwise.
- **ABSENT A WRITTEN SIGNED AGREEMENT, EXCEPT AS PROVIDED IN THE RELEVANT TERMS AND CONDITIONS OF SALE FOR PRODUCT, AND TO THE MAXIMUM EXTENT ALLOWABLE BY LAW, TOSHIBA (1) ASSUMES NO LIABILITY WHATSOEVER, INCLUDING WITHOUT LIMITATION, INDIRECT, CONSEQUENTIAL, SPECIAL, OR INCIDENTAL DAMAGES OR LOSS, INCLUDING WITHOUT LIMITATION, LOSS OF PROFITS, LOSS OF OPPORTUNITIES, BUSINESS INTERRUPTION AND LOSS OF DATA, AND (2) DISCLAIMS ANY AND ALL EXPRESS OR IMPLIED WARRANTIES AND CONDITIONS RELATED TO SALE, USE OF PRODUCT, OR INFORMATION, INCLUDING WARRANTIES OR CONDITIONS OF MERCHANTABILITY, FITNESS FOR A PARTICULAR PURPOSE, ACCURACY OF INFORMATION, OR NONINFRINGEMENT.**
- Do not use or otherwise make available Product or related software or technology for any military purposes, including without limitation, for the design, development, use, stockpiling or manufacturing of nuclear, chemical, or biological weapons or missile technology products (mass destruction weapons). Product and related software and technology may be controlled under the applicable export laws and regulations including, without limitation, the Japanese Foreign Exchange and Foreign Trade Law and the U.S. Export Administration Regulations. Export and re-export of Product or related software or technology are strictly prohibited except in compliance with all applicable export laws and regulations.
- Please contact your TOSHIBA sales representative for details as to environmental matters such as the RoHS compatibility of Product. Please use Product in compliance with all applicable laws and regulations that regulate the inclusion or use of controlled substances, including without limitation, the EU RoHS Directive. **TOSHIBA ASSUMES NO LIABILITY FOR DAMAGES OR LOSSES OCCURRING AS A RESULT OF NONCOMPLIANCE WITH APPLICABLE LAWS AND REGULATIONS.**