

Toshiba BiCD Process Integrated Circuit Silicon Monolithic

TB67S521FTAG

BiCD constant current two-phase bipolar stepping motor driver IC

The TB67S521FTAG is a PWM chopper type 2-phase bipolar stepping motor driver IC.

By applying the BiCD process, the TB67S521FTAG is rated at 40 V / 2.8 A (Absolute maximum ratings).

The on-chip V_{CC} regulator allows control of a stepping motor with a single V_M power supply.

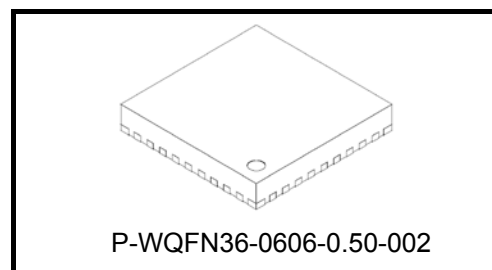

Weght: 0.14 g (typ.)

Features

- Bipolar stepping motor driver
- PWM constant current drive, PHASE-IN control
- Operational in full, half, and quarter step resolutions
- BiCD process: Use DMOSFET for the output power transistor.
- High withstand voltage and large current: 40 V / 2.8 A (Absolute maximum ratings)
- Built-in thermal shutdown circuit (TSD), over-current detection circuit (ISD), and POR
- Package: P-WQFN36-0606-0.50-002

Pin Assignment

(Top View)

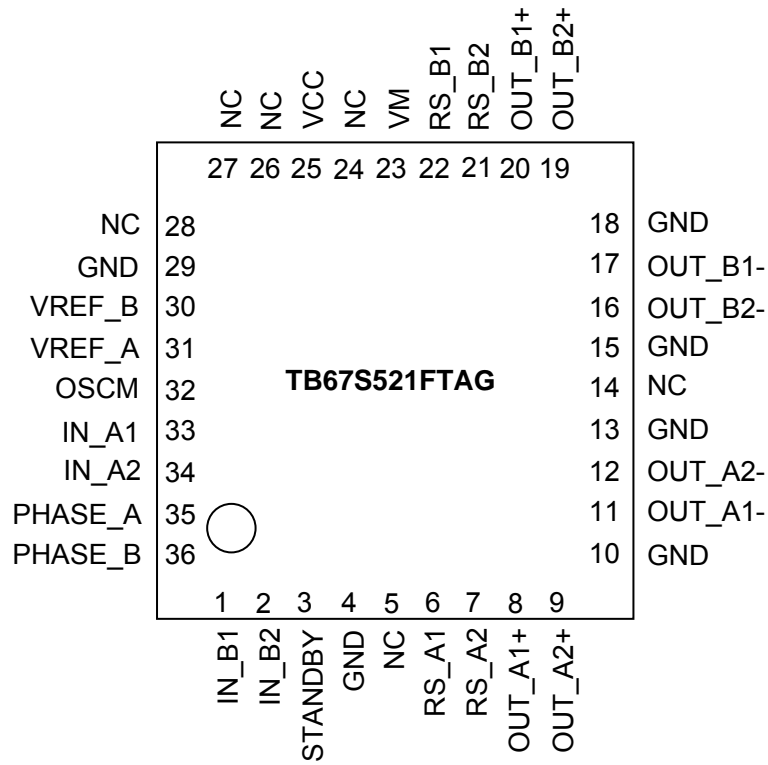

Block Diagram

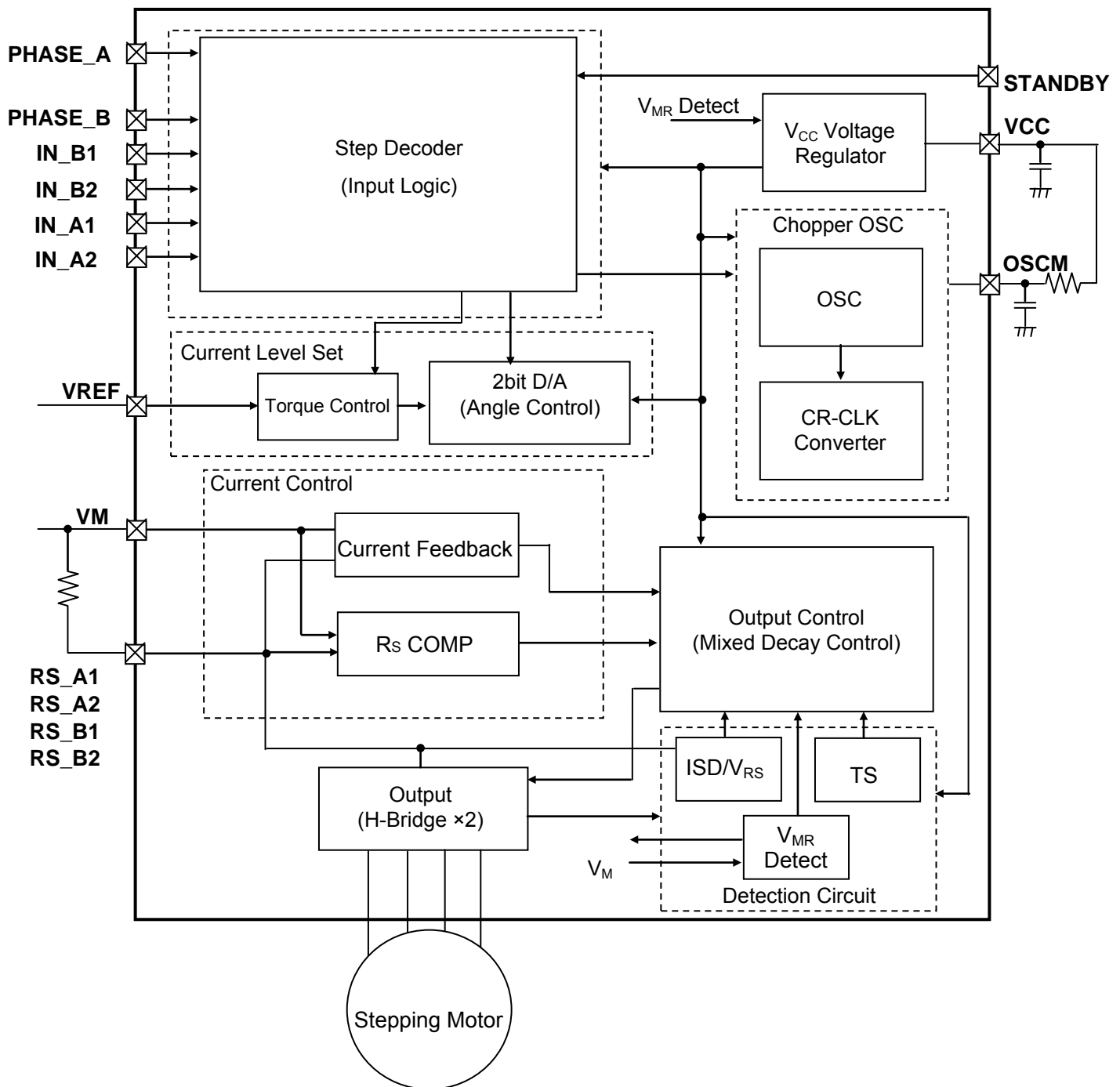

Some of the functional blocks, circuits, or constants in the block diagram may be omitted or simplified for explanatory purposes.

Note: All the grounding wires of the TB67S521FTAG should run on the solder mask on the PCB and be externally terminated at only one point. Also, a grounding method should be considered for efficient heat dissipation. Careful attention should be paid to the layout of the output, V_M and GND traces, to avoid short circuits across output pins or to the power supply or ground. If such a short circuit occurs, the device may be permanently damaged. Also, the utmost care should be taken for pattern designing and implementation of the device since it has power supply pins (V_M , RS_A1, RS_A2, RS_B1, RS_B2, OUT_A1+, OUT_A2+, OUT_A1-, OUT_A2-, OUT_B1+, OUT_B2+, OUT_B1-, OUT_B2-, and GND) through which a particularly large current may run. If these pins are wired incorrectly, an operation error may occur or the device may be destroyed. The logic input pins must also be wired correctly. Otherwise, the device may be damaged owing to a current running through the IC that is larger than the specified current. Careful attention should be paid to design patterns and mountings.

Pin Function Description

Pin number	Pin name	Function
1	IN_B1	B ch step resolution control pin 1
2	IN_B2	B ch step resolution control pin 2
3	STANDBY	All functions initialization and power saving mode (H: normal operation, L: operation stop)
4	GND	GND
5	NC	Non-connection
6	RS_A1 (Note)	Sense resistance connection pin for setting current value of A ch output
7	RS_A2 (Note)	Sense resistance connection pin for setting current value of A ch output
8	OUT_A1+ (Note)	A ch (+) output
9	OUT_A2+ (Note)	A ch (+) output
10	GND	A ch side power GND
11	OUT_A1- (Note)	A ch (-) output
12	OUT_A2- (Note)	A ch (-) output
13	GND	A ch side power GND
14	NC	Non-connection
15	GND	B ch side power GND
16	OUT_B2- (Note)	B ch (-) output
17	OUT_B1- (Note)	B ch (-) output
18	GND	B ch side power GND
19	OUT_B2+ (Note)	B ch (+) output
20	OUT_B1+ (Note)	B ch (+) output
21	RS_B2 (Note)	Sense resistance connection pin for setting current value of B ch output
22	RS_B1 (Note)	Sense resistance connection pin for setting current value of B ch output
23	VM	Monitor pin of motor power supply
24	NC	Non-connection
25	VCC	Monitor pin for internal generated 5V bias
26	NC	Non-connection
27	NC	Non-connection
28	NC	Non-connection
29	GND	GND
30	VREF_B	Bias pin for current value setting for B ch output
31	VREF_A	Bias pin for current value setting for A ch output
32	OSCM	Oscillation circuit frequency setting pin for chopping
33	IN_A1	A ch step resolution control pin 1
34	IN_A2	A ch step resolution control pin 2
35	PHASE_A	Signal input pin in direction of PWM current for A ch
36	PHASE_B	Signal input pin in direction of PWM current for B ch

The NC pin should be used open.

Note: Connect the same function pins (numbered 1, 2) indicated as (Note) after the terminal name at near their respective terminals

Input/Output Equivalent Circuit

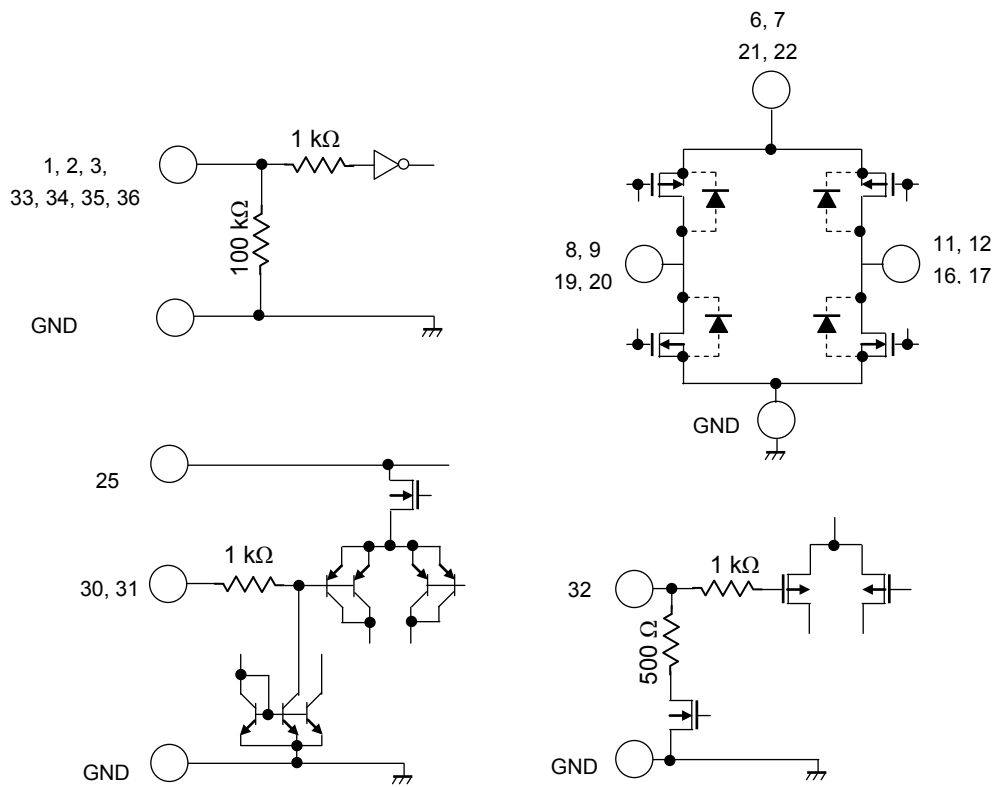

The equivalent circuit diagrams may be simplified or some parts of them may be omitted for explanatory purposes.

Pin No	Pin name
1	IN_B1
2	IN_B2
3	STANDBY
6,7	RS_A1, RS_A2
8,9	OUT_A1+, OUT_A2+
11,12	OUT_A1-, OUT_A2-
16,17	OUT_B2-, OUT_B1-
19,20	OUT_B2+, OUT_B1+
21,22	RS_B2, RS_B1
23	VM
25	VCC
30	VREF_B
31	VREF_A
32	OSCM
33	IN_A1
34	IN_A2
35	PHASE_A
36	PHASE_B

Function Table - Output

Input			Output		
PHASE_A PHASE_B	IN_A1 IN_B1	IN_A2 IN_B2	OUT_A1+ OUT_A2+ OUT_B1+ OUT_B2+	OUT_A1- OUT_A2- OUT_B1- OUT_B2-	I_{OUT}
H	H	H	H	L	100 %
	H	L	H	L	71 %
	L	H	H	L	38 %
	L	L	Output OFF	Output OFF	0 %
L	H	H	L	H	-100 %
	H	L	L	H	-71 %
	L	H	L	H	-38 %
	L	L	Output OFF	Output OFF	0 %

I_{OUT} : The current is defined “+(plus)” when the motor current flows from OUT_A1+ (OUT_A2+, OUT_B1+, OUT_B2+) -> OUT_A1- (OUT_A2-, OUT_B1-, OUT_B2-).

Also, the current is defined “-(minus)” when the motor current flows from OUT_A1- (OUT_A2-, OUT_B1-, OUT_B2-) -> OUT_A1+ (OUT_A2+, OUT_B1+, OUT_B2+).

Other Functions

Pin name	H	L	Notes
IN_A1 IN_A2 IN_B1 IN_B2	Output	Output OFF	When 'L' is input, the output becomes OFF (Hi-z) regardless of the PHASE state of the channel.
PHASE_A PHASE_B	OUT_A1+ (OUT_A2+, OUT_B1+,OUT_B2+) : H	OUT_A1- (OUT_A2-, OUT_B1-, OUT_B2-) : H	In the case of 'H', the current flows from OUT_A1+ (OUT_A2+, OUT_B1+, OUT_B2+) to OUT_A1- (OUT_A1-, OUT_B1-, OUT_B2-) normally.
STANDBY	Motor can be operated	IC function stop	When STANDBY = 'L', both OSC circuit and output stop. Motor cannot be driven.

Input the IN_A1, IN_A2, IN_B1, IN_B2, PHASE_A, and PHASE_B signals after reaching operating voltage of the motor to be used.

Detection Function

- (1) TSD (Thermal shutdown circuit)
The thermal shutdown circuit turns off all the outputs when the junction temperature (T_j) exceeds 150°C (typ.). The outputs retain the current states.
The TB67S521FTAG exits TSD mode and resumes normal operation when the TB67S521FTAG is rebooted or the STANDBY pin is changed from High to Low and then to High.
- (2) V_{MR} V_{CCR} and POR (Power-on-reset: V_M and V_{CC} voltage monitor)
The outputs are forced off until V_M and V_{CC} reach the rated voltages.
- (3) ISD (Over-current detection circuit)
This circuit has a function for stopping IC temporarily if the IC short-circuit occurs. When the current more than 2.1A flows to the output block, the internal reset runs, the output is forcibly turned OFF, and the state is held.
For reset, set the STANDBY from H to L and set H again or re-start the power supply.
The IC is in the STANDBY mode when the ISD is operating.

Absolute Maximum Ratings (Ta = 25°C)

Characteristic	Symbol	Rating	Unit
Motor power supply	V _M	40	V
Motor output voltage	V _{OUT}	40	V
Motor output current (Note1)	I _{OUT}	2.8	A/ch
Internal logic power supply	V _{CC}	6.0	V
Logic input voltage	V _{IN}	6.0	V
V _{ref} reference voltage	V _{ref}	5.0	V
Power dissipation (Note2)	P _D	1.3	W
Operating temperature	T _{opr}	-20 to 85	°C
Storage temperature	T _{stg}	-55 to 150	°C
Junction temperature	T _j (max)	150	°C

Note1: Maximum current value at normal operation should be used about 2 A per phase after thermal calculation. The maximum output current may be further limited in view of thermal considerations, depending on ambient temperature and board conditions.

Note2: When Ta exceeds 25°C for device alone measurement, please correct the PD values by de-rating at 10.4 mW/°C.

Ta : Ambient temperature of the IC

Topr : Ambient temperature while the IC is activate

Tj : Junction temperature while the IC is active. Tj(max) is limited by the thermal shutdown (TSD) circuitry.

It is advisable to keep the maximum current below a certain level so that the maximum junction temperature, Tj (max), will not exceed 120°C.

Absolute maximum ratings

The absolute maximum ratings of a semiconductor device are a set of ratings that must not be exceeded, even for a moment. Do not exceed any of these ratings.

Exceeding the rating (s) may cause device breakdown, damage or deterioration, and may result in injury by explosion or combustion.

The value of even one parameter of the absolute maximum ratings should not be exceeded under any circumstances. The TB67S521FTAG does not have overvoltage detection circuit. Therefore, the device is damaged if a voltage exceeding its rated maximum is applied.

All voltage ratings, including supply voltages, must always be followed. The other notes and considerations described later should also be referred to.

■ (Reference) Relation between power dissipation (single, PCB mounted) and ambient temperature

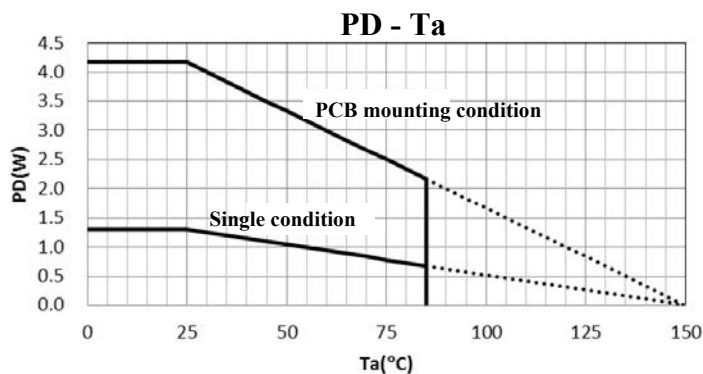

Board condition
 4 layers board for glass epoxy exclusive use
 Cu thickness: 1st layer and 4th layer 55μm, 2nd layer and 3rd layer 35μm
 Board size: 100mm × 110mm × 1.6mm

Operating Ranges (Ta = 0 to 85°C)

Characteristic	Symbol	Min	Typ.	Max	Unit	Remark
Motor power supply voltage	V _M	10.0	24.0	35.0	V	—
Motor output current	I _{OUT}	-	1.5	2.5	A	Per 1 channel (Note1)
Logic input voltage	V _{IN} (H)	2.0	—	5.5	V	Logic High level
	V _{IN} (L)	0	—	0.8	V	Logic Low level
Chopping frequency	f _{chop}	40	—	150	kHz	—
V _{ref} reference voltage	V _{ref}	GND	—	3.6	V	—
Sense resistance connection pin voltage	V _{RS}	0.0	±1.0	±1.5	V	Reference value: VM pin (Note2)

Note1: The actual maximum current may be limited by the operating environment (operating conditions such as excitation mode or operating duration, or by the surrounding temperature or board heat dissipation).

Confirm a realistic maximum current by calculating the heat generated under the operating environment.

Note2: The maximum V_{RS} voltage should not exceed the maximum rated voltage.

Electric Characteristic 1 (Unless otherwise specified, Ta = 25°C, V_M = 24 V)

Characteristic		Symbol	Test condition	Min	Typ.	Max	Unit
Logic input pin Input voltage	High	V _{IN} (H)	Logic input pin (Note)	2	3.3	5.5	V
	Low	V _{IN} (L)	Logic input pin (Note)	0	—	0.8	V
Input hysteresis		V _{IN} (HYS)	Logic input pin (Note)	100	200	300	mV
Logic input pin Input current	High	I _{IN} (H)	Test logic input pin: 5 V	35	50	75	μA
	Low	I _{IN} (L)	Test logic input pin: 0 V	—	—	1	μA
Current consumption		I _{M1}	Output: Open, STANDBY= 'L'	—	2	3	mA
		I _{M2}	Output: Open, STANDBY= 'H'	—	3.5	5	mA
		I _{M3}	Output: Open (Full step resolution)	—	5	7	mA
Motor output leak current	High	I _{OH}	V _{RS} = V _M = 40 V, V _{OUT} = 0 V	—	—	2	μA
	Low	I _{OL}	V _{RS} = V _M = V _{OUT} = 40 V	2	—	—	μA
Differential between output current channels		ΔI _{OUT1}	I _{OUT} = 2.0 A	-5	0	5	%
Output current setting differential		ΔI _{OUT2}	I _{OUT} = 2.0 A	-5	0	5	%
R _S pin current		I _{RS}	V _{RS} = V _M = 24 V	0	—	10	μA
Output transistor drain-source ON-resistance (H-side + L-side)		R _{ON(D-S)}	I _{OUT} = 2.0 A, T _j = 25°C (Design value)	—	0.53	0.64	Ω

Note: V_{IN} (H) is defined as the V_{IN} voltage that causes the outputs to change when a pin under test is gradually raised from 0V. V_{IN} (L) is defined as the V_{IN} voltage that causes the outputs to change when the pin is then gradually lowered.

The difference between V_{IN} (H) and V_{IN} (L) is defined as V_{IN} (HYS).

Electric Characteristic 2 (Unless otherwise specified, Ta = 25°C, V_M = 24 V)

Characteristic	Symbol	Test condition	Min	Typ.	Max	Unit
V _{ref} input current	I _{ref}	V _{ref} = 3.0 V	—	0	1	μA
V _{ref} delay ratio	V _{ref} (gain)	V _{ref} = 2.0 V	1/4.8	1/5.0	1/5.2	—
TSD temperature (Note1)	T _J TSD	—	140	150	170	°C
V _M return voltage	V _{MR}	—	7.0	8.0	9.0	V
ISD operation current (Note2)	ISD	(Design value)	3.0	4.0	5.0	A
Power supply voltage for internal circuit operation (Note3)	V _{CC}	I _{CC} = 5.0 mA	4.75	5.00	5.25	V

Note1: Thermal shut down (TSD) circuit

When the IC junction temperature reaches the specified value and become overheated under irregular conditions causing the TSD circuit to be activated, the internal halt circuit is activated shutting down all the outputs to off.

When the temperature is set between 140°C (min) to 170°C (max), the TSD circuit operates (design target value). When the TSD circuit is operating, it can be returned by re-starting the V_M power supply or setting the standby mode. The TSD function aims at detecting abnormal heating of ICs. Please avoid positively using the TSD function.

Note2: Over-current detection (ISD) circuit

When the current exceeding the specified value flows to the output under irregular conditions, the internal halt circuit is activated switching all the outputs to off. The blanking time is set to avoid the incorrect operation by switching. (For details, refer to "Over current detection blanking time" characteristic of "AC Electric Characteristic".)

When the ISD function is operating, the output is stopped until power-on-reset of the V_M power supply. It can be returned by re-starting the V_M power supply or setting the standby mode. The ISD function aims at detecting abnormal voltage of ICs. Please avoid positively using the ISD function.

Note3: When the power supply voltage (V_{CC}) for internal circuit operation is divided with external resistance and used as V_{ref} input voltage, the accuracy of the output setting value becomes ±8%, together with the accuracy of V_{CC} output and V_{ref} delay ratio.

Back-EMF

While a motor is rotating, there is a timing at which power is fed back to the power supply. At that timing, the motor current is fed back to the power supply owing to the effect of the motor back-EMF.

If the power supply does not have enough sink capability, the power supply and output pins of the device might rise above the rated voltages. The magnitude of the motor back-EMF varies with usage conditions and motor characteristics. It must be fully verified that there is no risk that the TB67S521FTAG or other components will be damaged or fail owing to the motor back-EMF.

Cautions on over-current shutdown (ISD) and thermal shutdown (TSD)

- The ISD and TSD circuits are only intended to provide temporary protection against irregular conditions such as an output short circuit, they do not necessarily guarantee complete IC safety.
- If the device is used beyond the specified operating ranges, these circuits may not operate properly, then the device may be damaged owing to an output short circuit.
- The ISD circuit is only intended to provide temporary protection against an output short circuit. If such a condition persists for a long time, the device may be damaged owing to overstress. Overcurrent conditions must be removed immediately by external hardware.

IC Mounting

Do not insert devices in the wrong orientation or incorrectly. Otherwise, it may cause device breakdown, damage and/or deterioration.

AC Electric Characteristic (Ta = 25°C, V_M = 24 V, 6.8 mH/5.7 Ω)

Characteristic	Symbol	Test condition	Min	Typ.	Max	Unit
PHASE frequency	f _{PHASE}	f _{CR} = 1600 kHz	—	—	400	kHz
Minimum PHASE width	t _{PHASE}	—	100	—	—	ns
	t _{wp}	—	50	—	—	ns
	t _{wn}	—	50	—	—	ns
Output transistor	t _r	—	100	150	200	ns
Switching characteristic	t _f	—	100	150	200	ns
Noise rejection blanking time	t _{BLANK}	I _{OUT} = 2.4 A	200	300	500	ns
OSCM oscillation frequency	f _{CR}	COSC = 270 pF, RO _{SC} = 3.6 kΩ	1200	1600	2000	kHz
Chopping frequency range	f _{chop} (range)	V _M = 24 V, Output ACTIVE (I _{OUT} = 2.4 A)	40	—	150	kHz
Chopping setting frequency	f _{chop}	Output ACTIVE (I _{OUT} = 2.4 A), f _{CR} = 1600 kHz	—	100	—	kHz
Over current detection blanking time (Note)	t _{ISD} (Mask)	After exceeding a threshold when the outputs are short-circuited to the power supply and GND	—	4	—	Osc-Clk
Operation time of over current detection (Note)	t _{ISD}		—	—	8	

Note: Count using number of clocks of OSCM clock after exceeding ISD threshold when the outputs are short-circuited to the power supply and GND.

Timing of output transistor switching characteristic

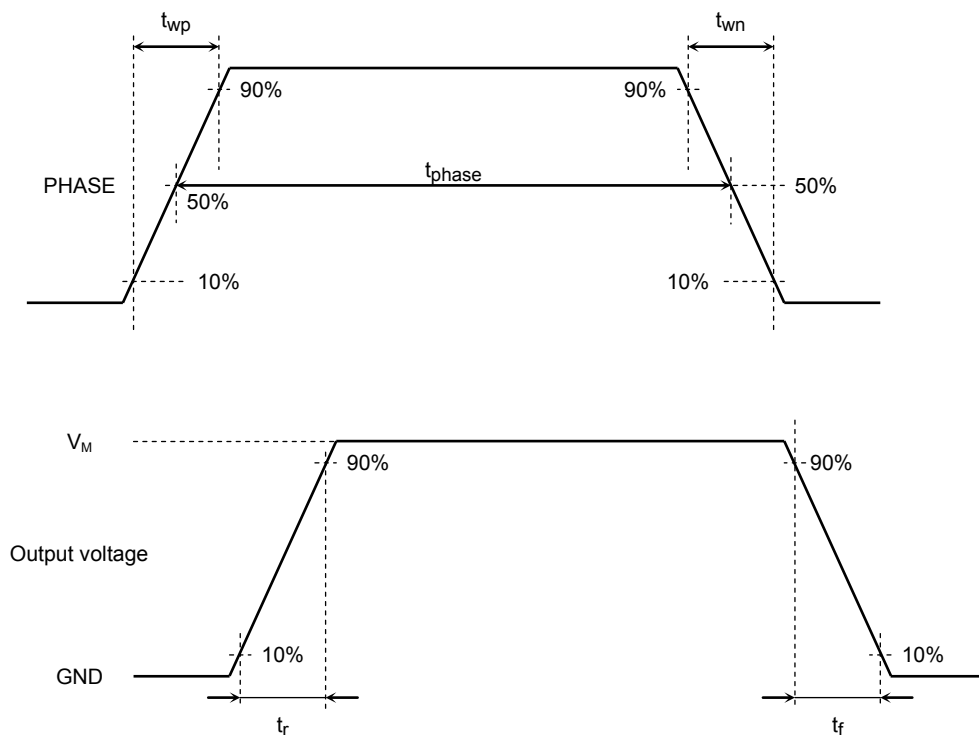

Timing charts may be simplified for explanatory purposes.

Mixed Decay Mode

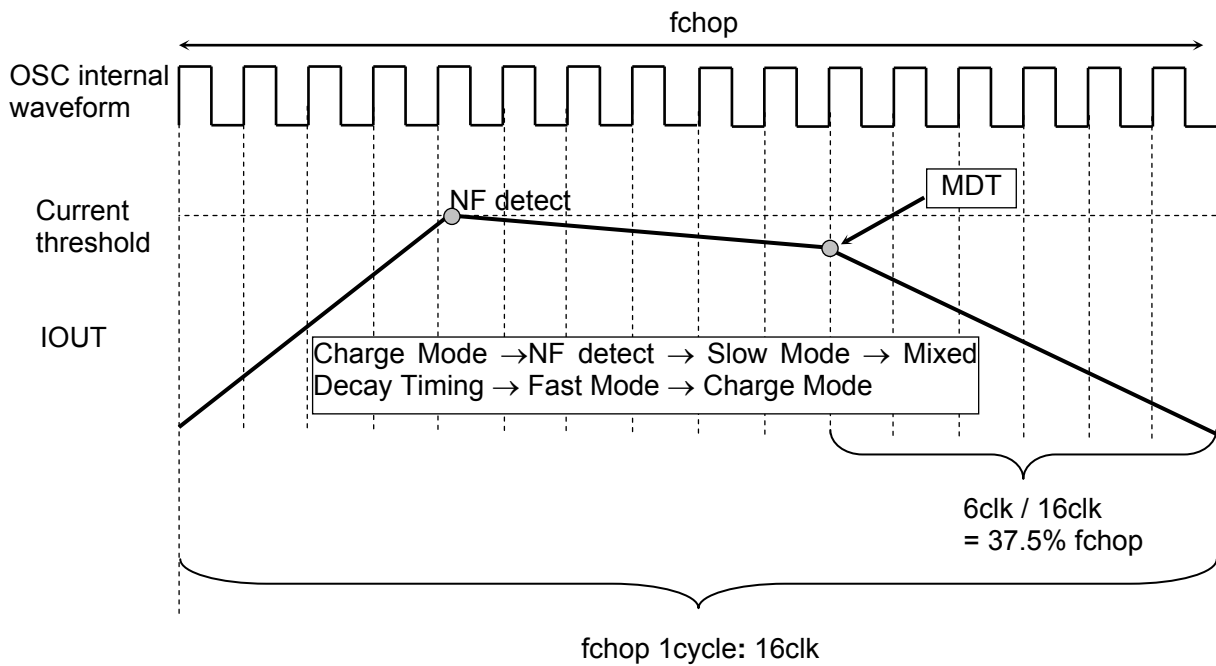

Mixed Decay Mode Sequence Waveform

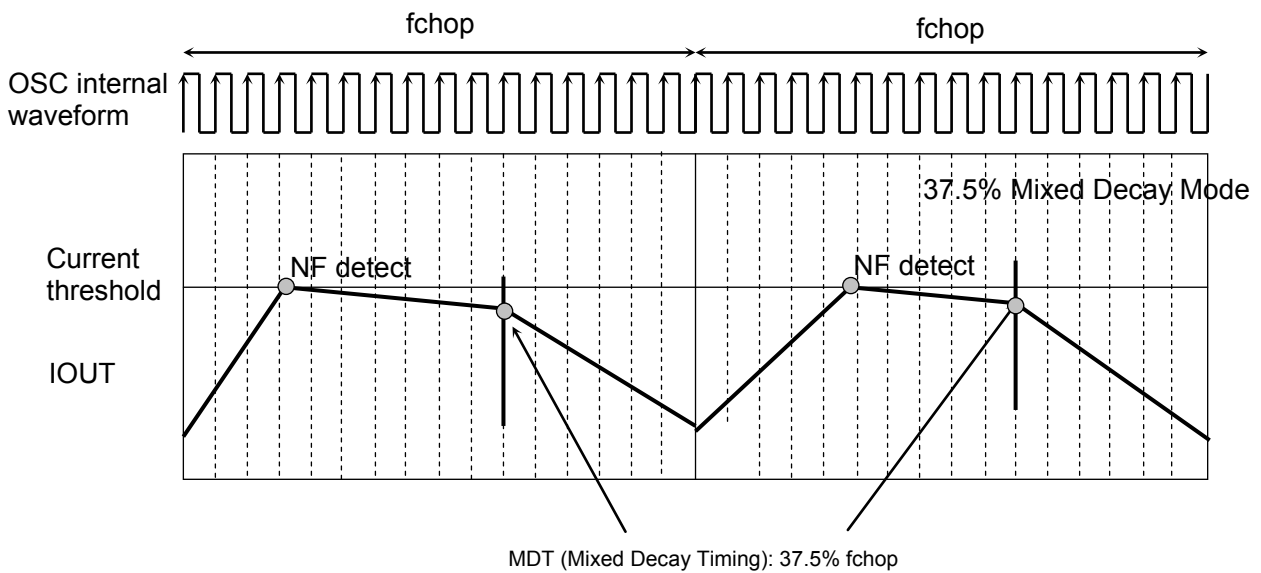

Timing charts may be simplified for explanatory purposes.

Mixed (Slow + Fast) Decay Mode Current Waveform

- When the next step's current threshold is more than that of the previous step

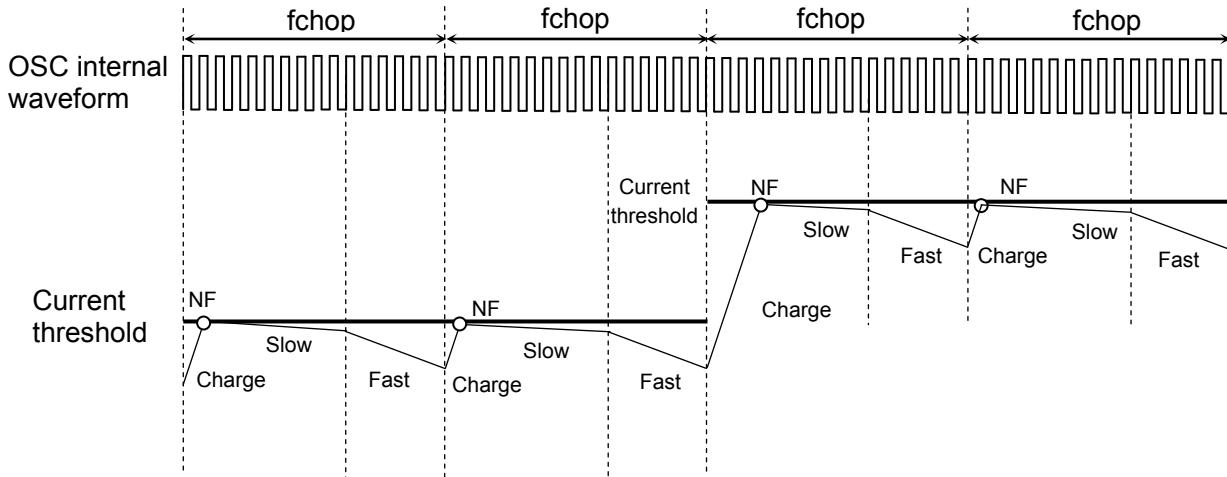

- When the next step's current threshold is less than that of the previous step

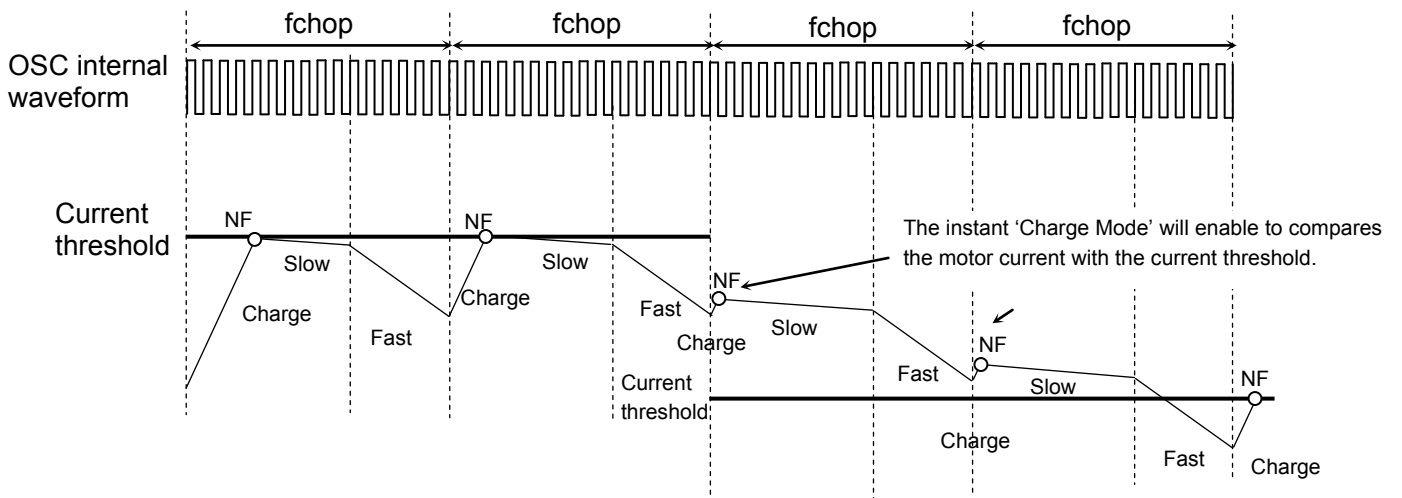

Timing charts may be simplified for explanatory purposes.

Output Transistor Operation Mode

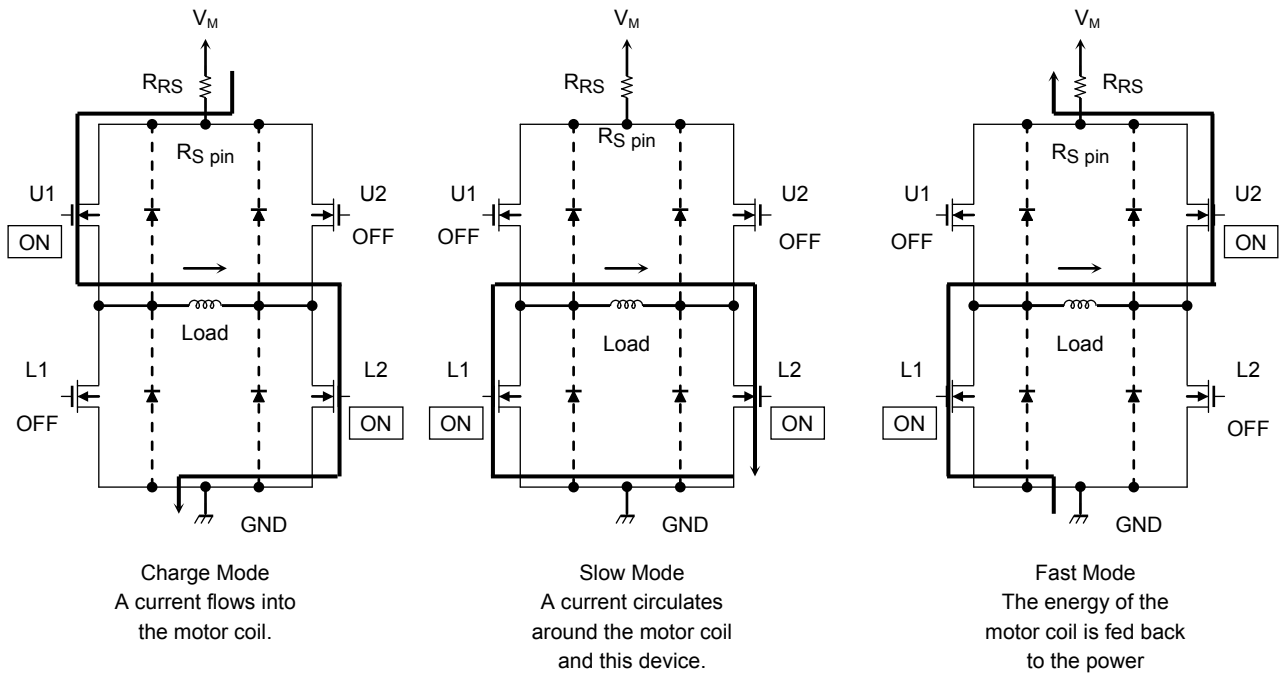

Output Transistor Operating Function

Mode	U1	L1	U2	L2
Charge	ON	OFF	OFF	ON
Slow	OFF	ON	OFF	ON
Fast	OFF	ON	ON	OFF

Note: This table shows an example of when the current flows as indicated by the arrows in the figures shown above. If the current flows in the opposite direction, refer to the following table.

Mode	U1	L1	U2	L2
Charge	OFF	ON	ON	OFF
Slow	OFF	ON	OFF	ON
Fast	ON	OFF	OFF	ON

Calculation of the Setting Current

This IC drives a motor by controlling the PWM constant current base of the OSCM oscillating frequency.

The peak output current can be set via the current-sensing resistor (RS) and the reference voltage (V_{ref}), as follows:

$$I_{out} (Max) = V_{ref} (gain) \times \frac{V_{ref} (V)}{R_{RS} (\Omega)}$$

V_{ref}(gain): V_{ref} decay ratio is 1 / 5.0 (typ.)

Example: In case of 100 % setting,

When V_{ref} = 3.0 V, Torque = 100 %, RS = 0.51 Ω,

constant current output value of the motor (Peak current) is calculated as follows;

$$I_{out} = 3.0 \text{ V} / 5.0 / 0.51 \text{ } \Omega = 1.18 \text{ A}$$

Calculation of OSCM oscillation frequency (chopping reference frequency)

An approximation of the OSCM oscillation frequency (f_{OSCM}) and chopper frequency (f_{chop}) can be calculated by the following formulas.

$$f_{OSCM} = 1 / [0.56 \times \{C_x(R_1 + 500)\}] \quad C_x, R_1: \text{External constants for OSCM (} C_x = 270 \text{ pF, } R_1 = 3.6 \text{ k}\Omega \text{)}$$

$$f_{chop} = f_{OSCM} / 16$$

If the chopping frequency is raised, the reappearance of a waveform is higher since the ripple of the current decreases. However the gate loss in the IC is raised and the heat generation becomes large.

It is expected that the heat generation is reduced by being lowered the chopping frequency, but the current ripple may be increased. Generally it is recommended that the reference frequency is set as 70 kHz, the range from 50 kHz to 100 kHz.

IC Power Consumption

Power of the IC is consumed by the transistor of the output block and that of the logic block mainly.

1. Power consumed of power transistor (calculated as R_{on} H-side + L-side = 0.6Ω)

The power of output blocks is consumed by the transistor placed at H-side and L-side of H-bridge.

The power of a transistor of one H bridge can be shown in the following formula.

$$P(\text{out}) = I_{\text{out}}(\text{A}) \times V_{\text{DS}}(\text{V}) = I_{\text{out}}(\text{A})^2 \times R_{\text{on}}(\Omega) \dots\dots\dots (1)$$

In the case of full step resolution, when the output current waveform becomes completely square waveform, the average power consumption can be calculated as follows.

In the case of $R_{\text{on}} = 0.6\Omega$, $I_{\text{out}}(\text{peak: Max}) = 1.0 \text{ A}$, $V_{\text{M}} = 24 \text{ V}$,

$$P(\text{out}) = 2(\text{Tr}) \times 1.0(\text{A})^2 \times 0.6(\Omega) \dots\dots\dots (2)$$

$$= 1.2(\text{W})$$

2. Power consumption of logic and IM domain

Power consumptions of logic and IM systems are calculated by separating the states (operating and stopping).

- I (IM3) = 5 mA (typ.): Operating /axis
- I (IM2) = 3.5 mA (typ.): Stopping /axis
- I (IM1) = 2 mA (typ.): Standby /axis

Output block are connected to V_{M} (24V). (Output block: Current consumed by the circuit connected to V_{M} + Current consumed by switching output steps)

Power consumption is calculated as follows;

$$P(\text{IM3}) = 24(\text{V}) \times 0.005(\text{A}) \dots\dots\dots (3)$$

$$= 0.12(\text{W})$$

3. Power consumption

Total power consumption P is calculated from the values of formula (2) and (3).

$$P = P(\text{out}) + P(\text{IM3}) = 1.32(\text{W})$$

Moreover the power consumption of one axis in standby is as follows.

$$P(\text{in standby}) = 24(\text{V}) \times 0.002(\text{A}) = 0.048(\text{W})$$

For the heat design of the board, evaluate enough, and configure the appropriate margin.

Sequence According to Drive Mode

Sequence of Full Step Resolution

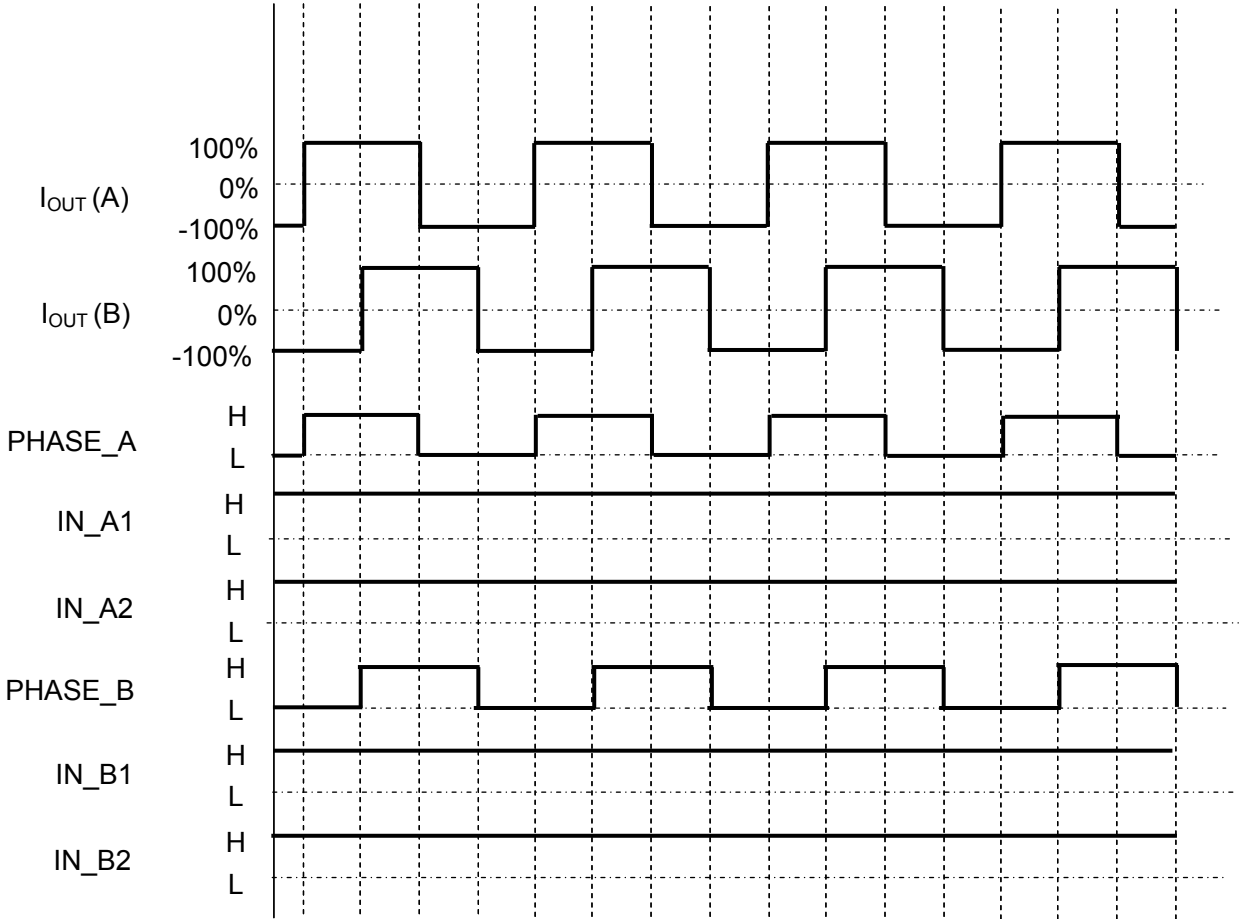

Timing charts may be simplified for explanatory purposes.

Sequence of Half Step Resolution

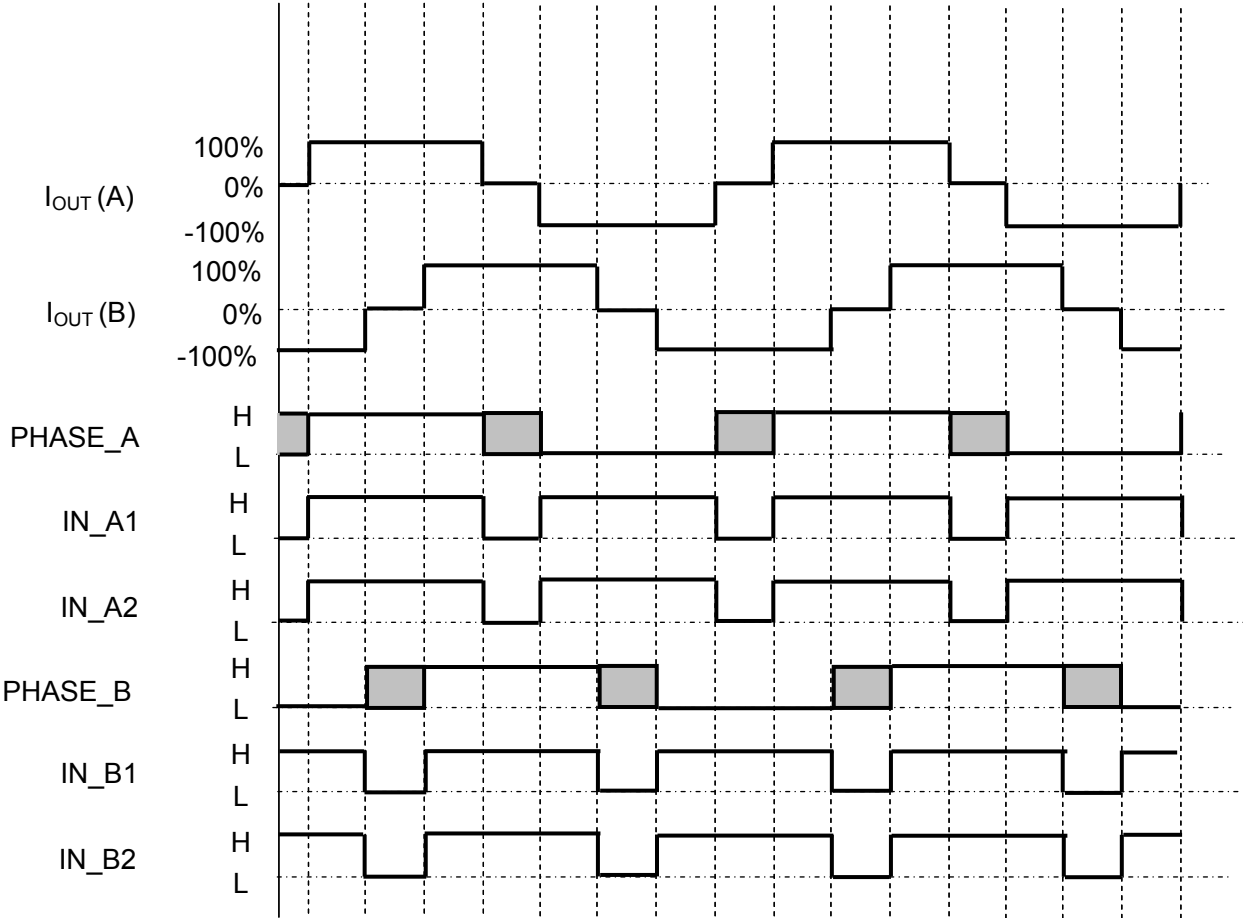

Timing charts may be simplified for explanatory purposes.

Sequence of Quarter Step Resolution

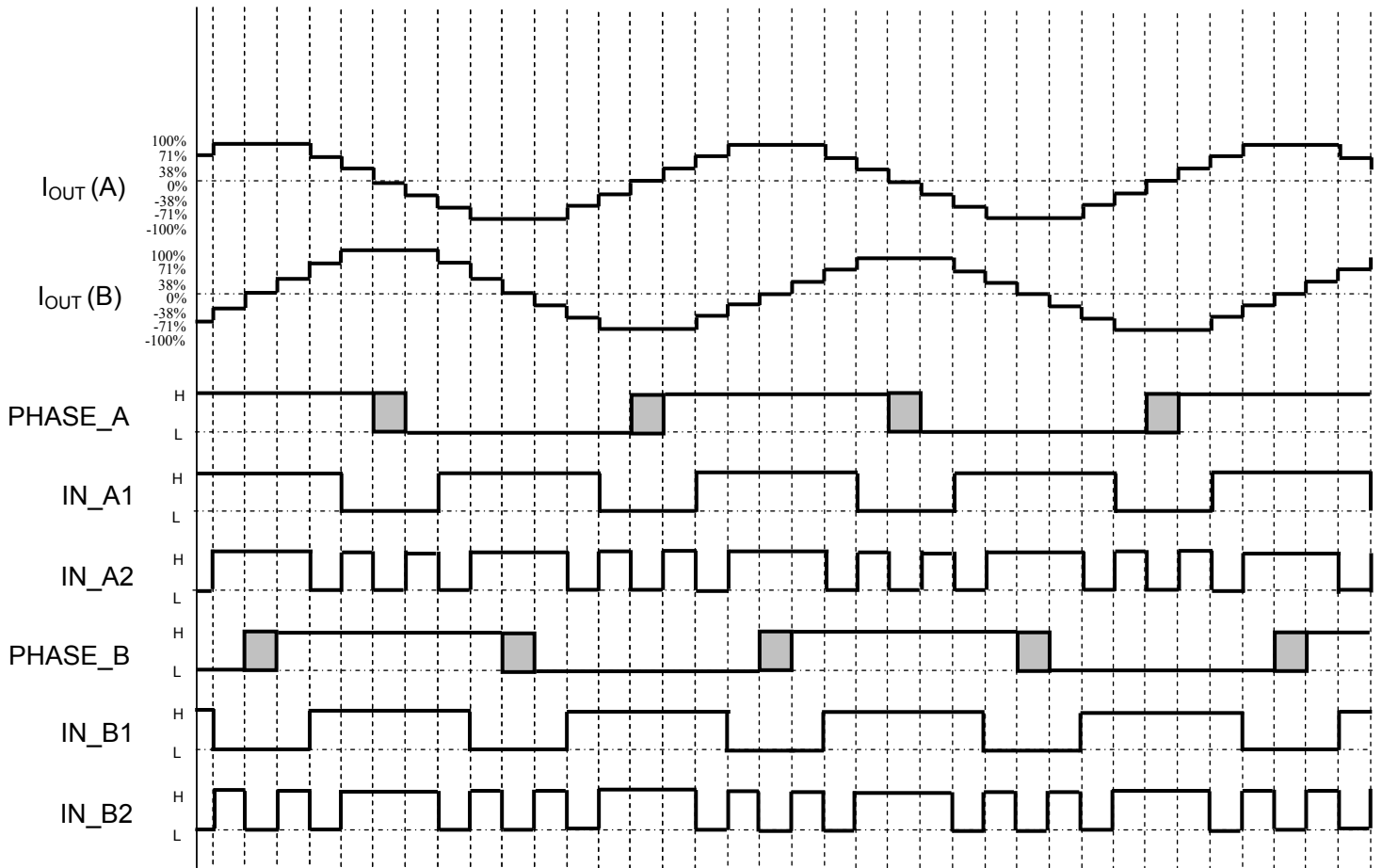

Timing charts may be simplified for explanatory purposes.

Example of Application Circuit (Chopping Frequency: 70 kHz)

The values shown in the following figure are recommended values. For input conditions, see the Operating Ranges.

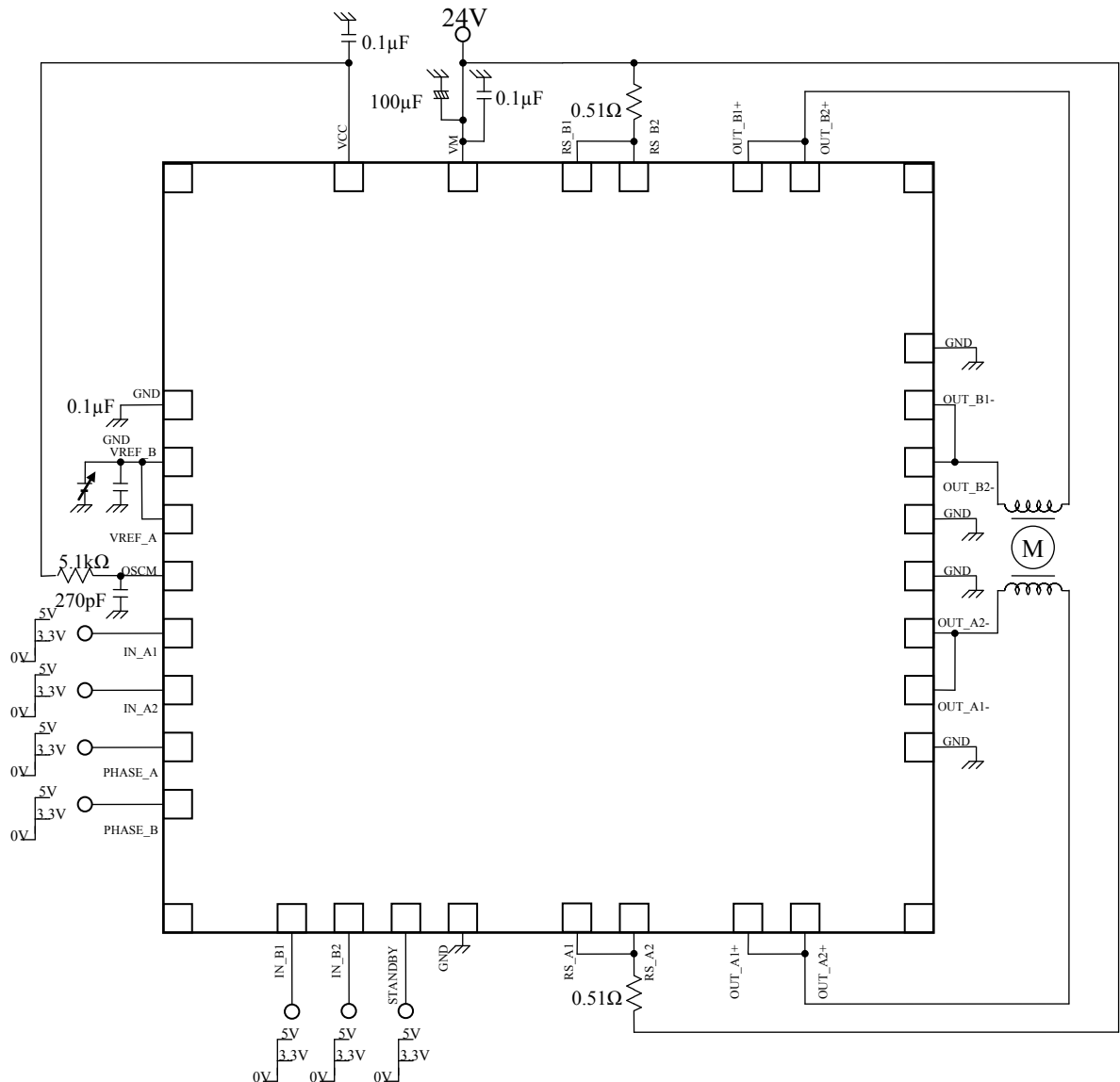

Note: It is recommended that a bypass capacitor is added if necessary. The GND wiring must become one-point-earth as much as possible and designed in consideration with heat dissipation. When the setting pin of each mode is controlled by a switch, pull up or pull down to prevent high impedance state. For input data, refer to the function description.

The example of an applied circuit is for reference, and enough evaluation should be done before the mass-production design. Moreover, it is not the one to permit the use of the industrial property. Components in the circuit are used to confirm characteristics. Therefore it is not ensured that the malfunction or failure of applications do not occur.

Careful attention should be paid to the layout of the output, V_M and GND traces, to avoid short circuits across output pins or to the power supply or ground. If such a short circuit occurs, the device may be permanently damaged. Moreover if positive and negative power supply pins are wrong way around, the IC may be destroyed because high resistance voltage is applied to low resistance voltage element. The board mounting should be careful. Also this product does not incorporate an over-voltage protection circuit. Therefore, IC may be destroyed if over-voltage more than specified value is applied. Please use the power supply in specification range.

Package Dimensions

P-WQFN36-0606-0.50-002

Unit:mm

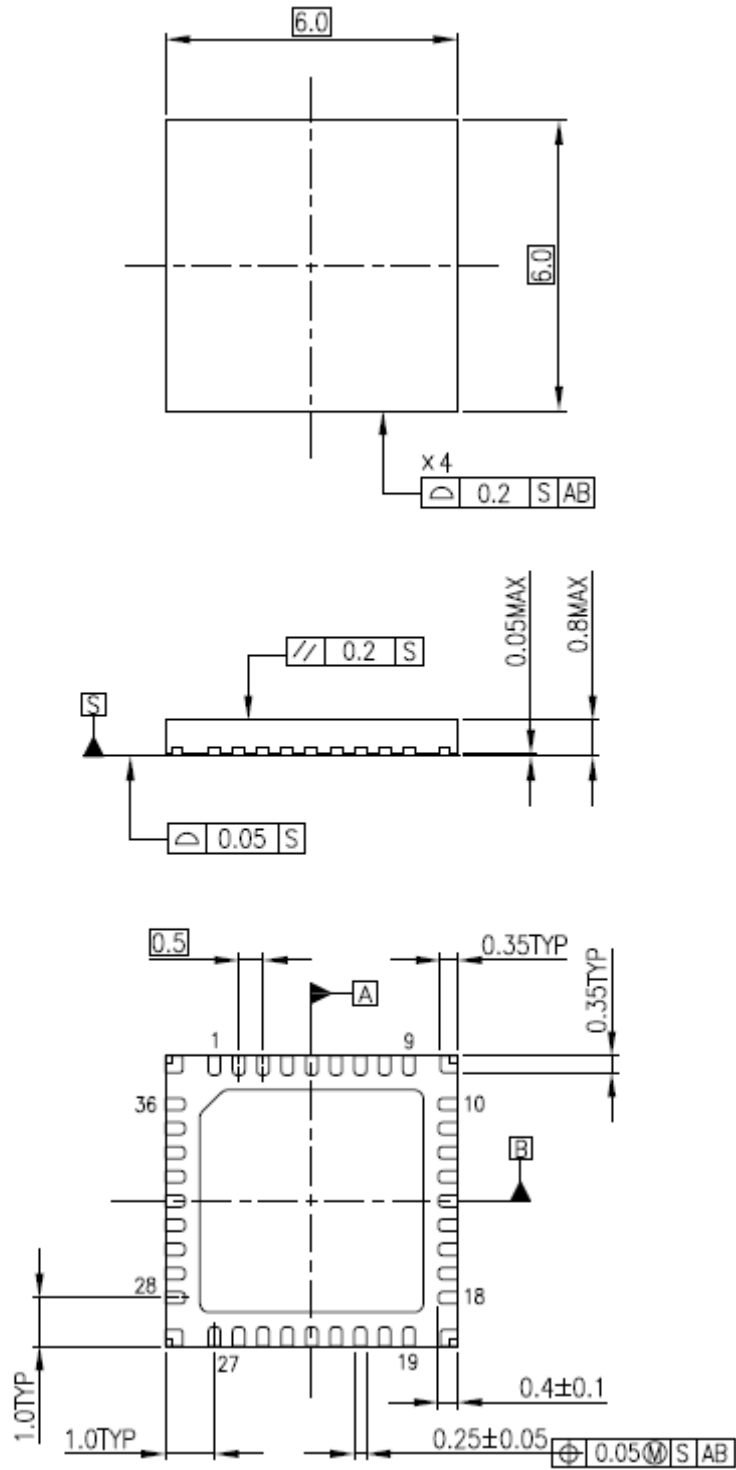

Weight: 0.14 g (typ.)

Note on Contents**(1) Block Diagrams**

Some of the functional blocks, circuits, or constants in the block diagram may be omitted or simplified for explanatory purposes.

(2) Timing Charts

Timing charts may be simplified for explanatory purposes.

(3) Application Circuits

The application circuits shown in this document are provided for reference purposes only. Thorough evaluation is required, especially at the mass production design stage.

Toshiba does not grant any license to any industrial property rights by providing these examples of application circuits.

IC Usage Considerations**Notes on Handling of ICs**

- (1) The absolute maximum ratings of a semiconductor device are a set of ratings that must not be exceeded, even for a moment. Do not exceed any of these ratings.
Exceeding the rating(s) may cause the device breakdown, damage or deterioration, and may result injury by explosion or combustion
- (2) Do not insert devices in the wrong orientation or incorrectly.
Make sure that the positive and negative terminals of power supplies are connected properly.
Otherwise, the current or power consumption may exceed the absolute maximum rating, and exceeding the rating(s) may cause the device breakdown, damage or deterioration, and may result injury by explosion or combustion.
In addition, do not use any device that is applied the current with inserting in the wrong orientation or incorrectly even just one time.
- (3) Use an appropriate power supply fuse to ensure that a large current does not continuously flow in case of over-current and/or IC failure. The IC will fully break down when used under conditions that exceed its absolute maximum ratings, when the wiring is routed improperly or when an abnormal pulse noise occurs from the wiring or load, causing a large current to continuously flow and the breakdown can lead smoke or ignition. To minimize the effects of the flow of a large current in case of breakdown, appropriate settings, such as Fast-blow fuse capacity, fusing time and insertion circuit location, are required.
- (4) If your design includes an inductive load such as a motor coil, incorporate a protection circuit into the design to prevent device malfunction or breakdown caused by the current resulting from the inrush current at power ON or the negative current resulting from the back electromotive force at power OFF. IC breakdown may cause injury, smoke or ignition.
Use a stable power supply with ICs with built-in protection functions. If the power supply is unstable, the protection function may not operate, causing IC breakdown. IC breakdown may cause injury, smoke or ignition.
- (5) Carefully select external components (such as inputs and negative feedback capacitors) and load components (such as speakers), for example, power amp and regulator.
If there is a large amount of leakage current such as input or negative feedback capacitor, the IC output DC voltage will increase. If this output voltage is connected to a speaker with low input withstand voltage, over-current or IC failure can cause smoke or ignition. (The over-current can cause smoke or ignition from the IC itself.) In particular, please pay attention when using a Bridge Tied Load (BTL) connection type IC that inputs output DC voltage to a speaker directly.

Points to Remember on Handling of ICs**(1) Over-current Protection Circuit**

Over-current protection circuits (referred to as current limiter circuits) do not necessarily protect ICs under all circumstances. If the Over-current protection circuits operate against the over-current, clear the over-current status immediately.

Depending on the method of use and usage conditions, such as exceeding absolute maximum ratings can cause the over-current protection circuit to not operate properly or IC breakdown before operation. In addition, depending on the method of use and usage conditions, if over-current continues to flow for a long time after operation, the IC may generate heat resulting in breakdown.

(2) Thermal Shutdown Circuit

Thermal shutdown circuits do not necessarily protect ICs under all circumstances. If the thermal shutdown circuits operate against the over temperature, clear the heat generation status immediately.

Depending on the method of use and usage conditions, such as exceeding absolute maximum ratings can cause the thermal shutdown circuit to not operate properly or IC breakdown before operation.

(3) Heat Radiation Design

In using an IC with large current flow such as power amp, regulator or driver, please design the device so that heat is appropriately radiated, not to exceed the specified junction temperature (T_j) at any time and condition. These ICs generate heat even during normal use. An inadequate IC heat radiation design can lead to decrease in IC life, deterioration of IC characteristics or IC breakdown. In addition, please design the device taking into consideration the effect of IC heat radiation with peripheral components.

(4) Back-EMF

When a motor rotates in the reverse direction, stops or slows down abruptly, a current flow back to the motor's power supply due to the effect of back-EMF. If the current sink capability of the power supply is small, the device's motor power supply and output pins might be exposed to conditions beyond absolute maximum ratings. To avoid this problem, take the effect of back-EMF into consideration in system design.

RESTRICTIONS ON PRODUCT USE

- Toshiba Corporation, and its subsidiaries and affiliates (collectively "TOSHIBA"), reserve the right to make changes to the information in this document, and related hardware, software and systems (collectively "Product") without notice.
- This document and any information herein may not be reproduced without prior written permission from TOSHIBA. Even with TOSHIBA's written permission, reproduction is permissible only if reproduction is without alteration/omission.
- Though TOSHIBA works continually to improve Product's quality and reliability, Product can malfunction or fail. Customers are responsible for complying with safety standards and for providing adequate designs and safeguards for their hardware, software and systems which minimize risk and avoid situations in which a malfunction or failure of Product could cause loss of human life, bodily injury or damage to property, including data loss or corruption. Before customers use the Product, create designs including the Product, or incorporate the Product into their own applications, customers must also refer to and comply with (a) the latest versions of all relevant TOSHIBA information, including without limitation, this document, the specifications, the data sheets and application notes for Product and the precautions and conditions set forth in the "TOSHIBA Semiconductor Reliability Handbook" and (b) the instructions for the application with which the Product will be used with or for. Customers are solely responsible for all aspects of their own product design or applications, including but not limited to (a) determining the appropriateness of the use of this Product in such design or applications; (b) evaluating and determining the applicability of any information contained in this document, or in charts, diagrams, programs, algorithms, sample application circuits, or any other referenced documents; and (c) validating all operating parameters for such designs and applications. **TOSHIBA ASSUMES NO LIABILITY FOR CUSTOMERS' PRODUCT DESIGN OR APPLICATIONS.**
- **PRODUCT IS NEITHER INTENDED NOR WARRANTED FOR USE IN EQUIPMENTS OR SYSTEMS THAT REQUIRE EXTRAORDINARILY HIGH LEVELS OF QUALITY AND/OR RELIABILITY, AND/OR A MALFUNCTION OR FAILURE OF WHICH MAY CAUSE LOSS OF HUMAN LIFE, BODILY INJURY, SERIOUS PROPERTY DAMAGE AND/OR SERIOUS PUBLIC IMPACT ("UNINTENDED USE").** Except for specific applications as expressly stated in this document, Unintended Use includes, without limitation, equipment used in nuclear facilities, equipment used in the aerospace industry, Class 3 medical devices, equipment used for automobiles, and military vehicles and munitions. **IF YOU USE PRODUCT FOR UNINTENDED USE, TOSHIBA ASSUMES NO LIABILITY FOR PRODUCT.** For details, please contact your TOSHIBA sales representative or contact us via our website.
- Do not disassemble, analyze, reverse-engineer, alter, modify, translate or copy Product, whether in whole or in part.
- Product shall not be used for or incorporated into any products or systems whose manufacture, use, or sale is prohibited under any applicable laws or regulations.
- The information contained herein is presented only as guidance for Product use. No responsibility is assumed by TOSHIBA for any infringement of patents or any other intellectual property rights of third parties that may result from the use of Product. No license to any intellectual property right is granted by this document, whether express or implied, by estoppel or otherwise.
- **ABSENT A WRITTEN SIGNED AGREEMENT, EXCEPT AS PROVIDED IN THE RELEVANT TERMS AND CONDITIONS OF SALE FOR PRODUCT, AND TO THE MAXIMUM EXTENT ALLOWABLE BY LAW, TOSHIBA (1) ASSUMES NO LIABILITY WHATSOEVER, INCLUDING WITHOUT LIMITATION, INDIRECT, CONSEQUENTIAL, SPECIAL, OR INCIDENTAL DAMAGES OR LOSS, INCLUDING WITHOUT LIMITATION, LOSS OF PROFITS, LOSS OF OPPORTUNITIES, BUSINESS INTERRUPTION AND LOSS OF DATA, AND (2) DISCLAIMS ANY AND ALL EXPRESS OR IMPLIED WARRANTIES AND CONDITIONS RELATED TO SALE, USE OF PRODUCT, OR INFORMATION, INCLUDING WARRANTIES OR CONDITIONS OF MERCHANTABILITY, FITNESS FOR A PARTICULAR PURPOSE, ACCURACY OF INFORMATION, OR NONINFRINGEMENT.**
- Do not use or otherwise make available Product or related software or technology for any military purposes, including without limitation, for the design, development, use, stockpiling or manufacturing of nuclear, chemical, or biological weapons or missile technology products (mass destruction weapons). Product and related software and technology may be controlled under the applicable export laws and regulations including, without limitation, the Japanese Foreign Exchange and Foreign Trade Law and the U.S. Export Administration Regulations. Export and re-export of Product or related software or technology are strictly prohibited except in compliance with all applicable export laws and regulations.
- Please contact your TOSHIBA sales representative for details as to environmental matters such as the RoHS compatibility of Product. Please use Product in compliance with all applicable laws and regulations that regulate the inclusion or use of controlled substances, including without limitation, the EU RoHS Directive. **TOSHIBA ASSUMES NO LIABILITY FOR DAMAGES OR LOSSES OCCURRING AS A RESULT OF NONCOMPLIANCE WITH APPLICABLE LAWS AND REGULATIONS.**