

TOSHIBA Intelligent Power Device  
High Voltage 3-phase motor driver IC

# TPD4206F

The TPD4206F is a DC brush less motor driver using high voltage PWM control. It is fabricated by high voltage MOSFET (500 V). It is three-shunt resistor circuit for current sensing. It contains level shift high-side driver, low-side driver, MOSFET outputs, and protective functions for over-current circuit and shutdown function and under voltage protection circuits and thermal shutdown circuit. It is easy to control a DC brush less motor by just putting logic inputs from a MPU or motor controller to the TPD4206F.

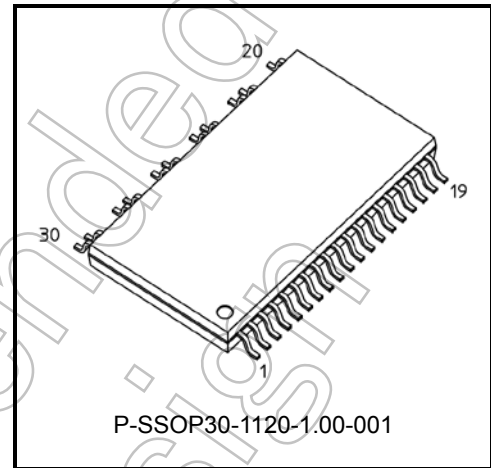

Weight: 1.2 g (typ.)

## Features

- High voltage power side and low voltage signal side terminal are separated.
- It is the best for current sensing in three shunt resistance.
- Bootstrap circuit gives simple high-side supply.
- Bootstrap diodes are built in.
- A dead time can be set as a minimum of 1.4  $\mu$ s, and it is suitable for a Sine-wave drive.
- 3-phase bridge output using MOSFETs.
- Included over-current and under-voltage protection and shutdown, and thermal shutdown.
- The regulator of 7 V (typ.) is built in.
- The package is a surface mount type 30 pin package.

This product has a MOS structure and is sensitive to electrostatic discharge. When handling this product, ensure that the environment is protected against electrostatic discharge.

The TSD and UVLO circuits are only intended to provide temporary protection against irregular condition such as an output short-circuit; they do not necessarily guarantee the complete IC safety. If the device is used beyond the specified operating ranges, these circuits may not operate properly; then the device may be damaged. Such a condition must be removed immediately by external hardware.

Start of commercial production  
2017-01

**Pin Assignment**

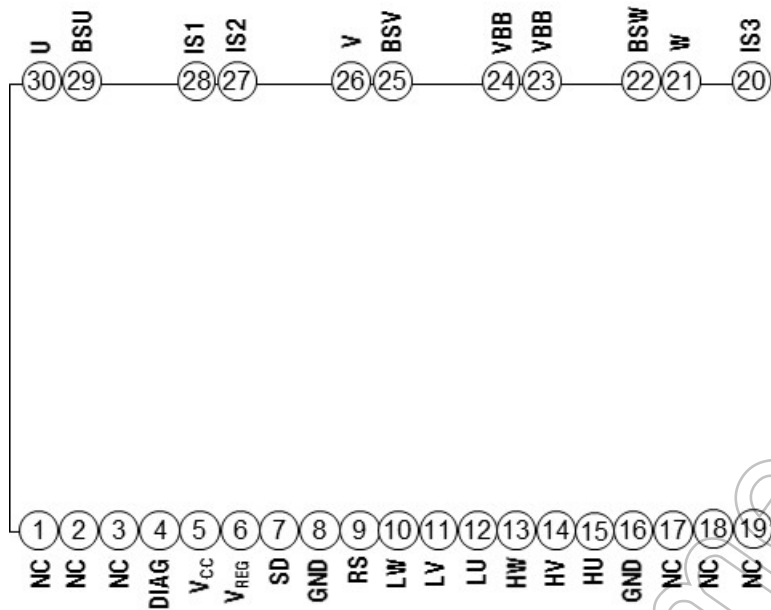

**Marking**

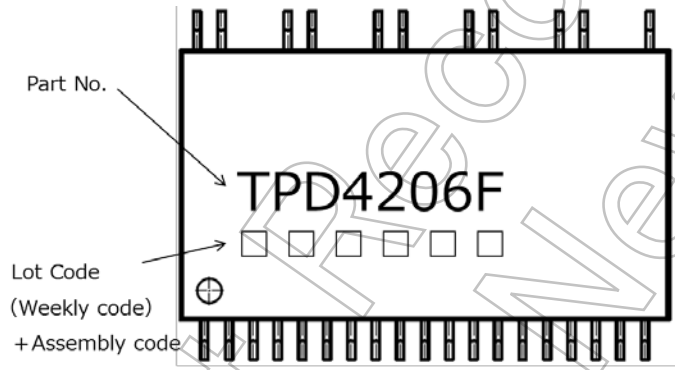

**Block Diagram**

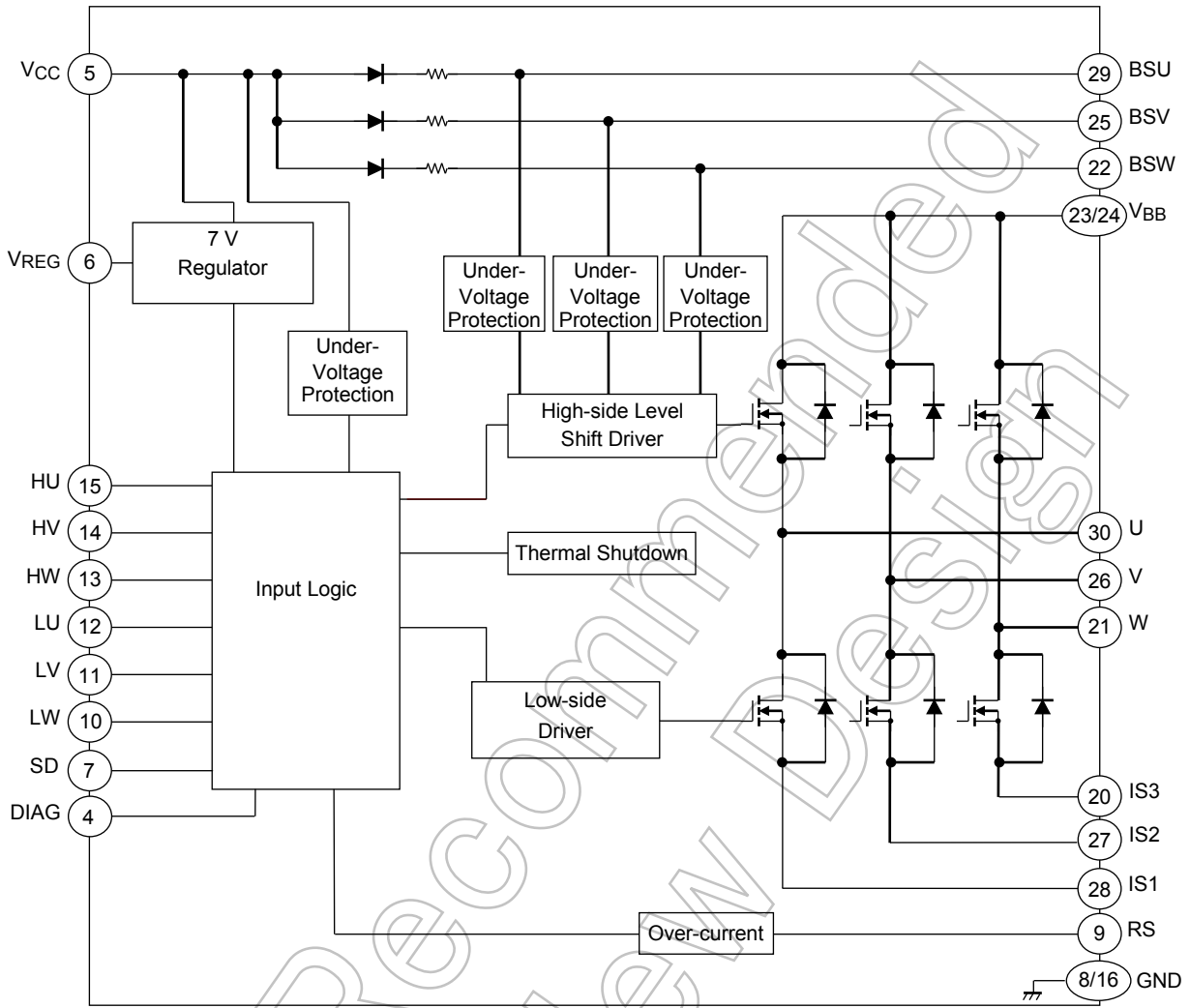

Not Recommended for New

## Pin Description

Pin No.	Symbol	Pin Description
1	NC	Unused pin, which is not connected to the chip internally.
2	NC	Unused pin, which is not connected to the chip internally.
3	NC	Unused pin, which is not connected to the chip internally.
4	DIAG	With the diagnostic output terminal of open drain, a pull-up is carried out by resistance. It turns on at the time of unusual.
5	VCC	Control power supply pin. (15 V (typ.))
6	VREG	7V regulator output pin.
7	SD	Input pin of external protection. ("L" active, It doesn't have hysteresis.)
8	GND	Ground pin.
9	RS	Over current detection pin.
10	LW	The control terminal of MOSFET by the low side of W. It turns off less than 1.5 V. It turns on more than 2.5 V.
11	LV	The control terminal of MOSFET by the low side of V. It turns off less than 1.5 V. It turns on more than 2.5 V.
12	LU	The control terminal of MOSFET by the low side of U. It turns off less than 1.5 V. It turns on more than 2.5 V.
13	HW	The control terminal of MOSFET by the high side of W. It turns off less than 1.5 V. It turns on more than 2.5 V.
14	HV	The control terminal of MOSFET by the high side of V. It turns off less than 1.5 V. It turns on more than 2.5 V.
15	HU	The control terminal of MOSFET by the high side of U. It turns off less than 1.5 V. It turns on more than 2.5 V.
16	GND	Ground pin.
17	NC	Unused pin, which is not connected to the chip internally.
18	NC	Unused pin, which is not connected to the chip internally.
19	NC	Unused pin, which is not connected to the chip internally.
20	IS3	The source terminal of MOSFET by the low side of W.
21	W	W-phase output pin.
22	BSW	W-phase bootstrap capacitor connecting pin.
23	VBB	High-voltage power supply input pin.
24	VBB	High-voltage power supply input pin.
25	BSV	V-phase bootstrap capacitor connecting pin.
26	V	V-phase output pin.
27	IS2	The source terminal of MOSFET by the low side of V.
28	IS1	The source terminal of MOSFET by the low side of U.
29	BSU	U-phase bootstrap capacitor connecting pin.
30	U	U-phase output pin.

**Equivalent Circuit of Input Pins**

**Internal circuit diagram of HU, HV, HW, LU, LV, LW input pins**

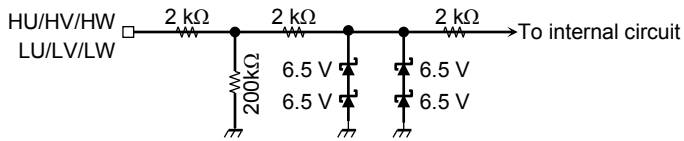

**Internal circuit diagram of SD pin**

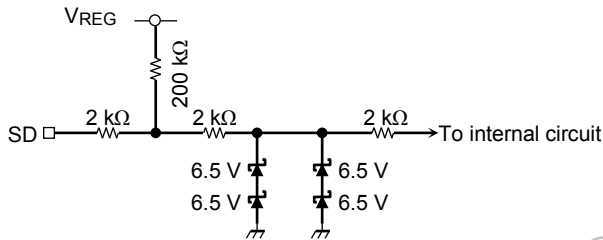

**Internal circuit diagram of RS pin**

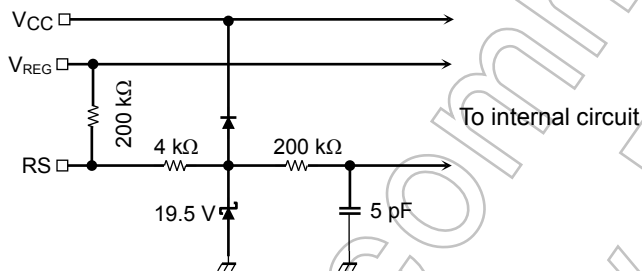

**Internal circuit diagram of DIAG pin**

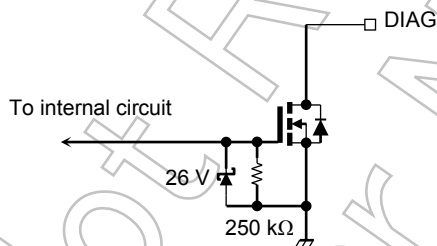

Timing Chart

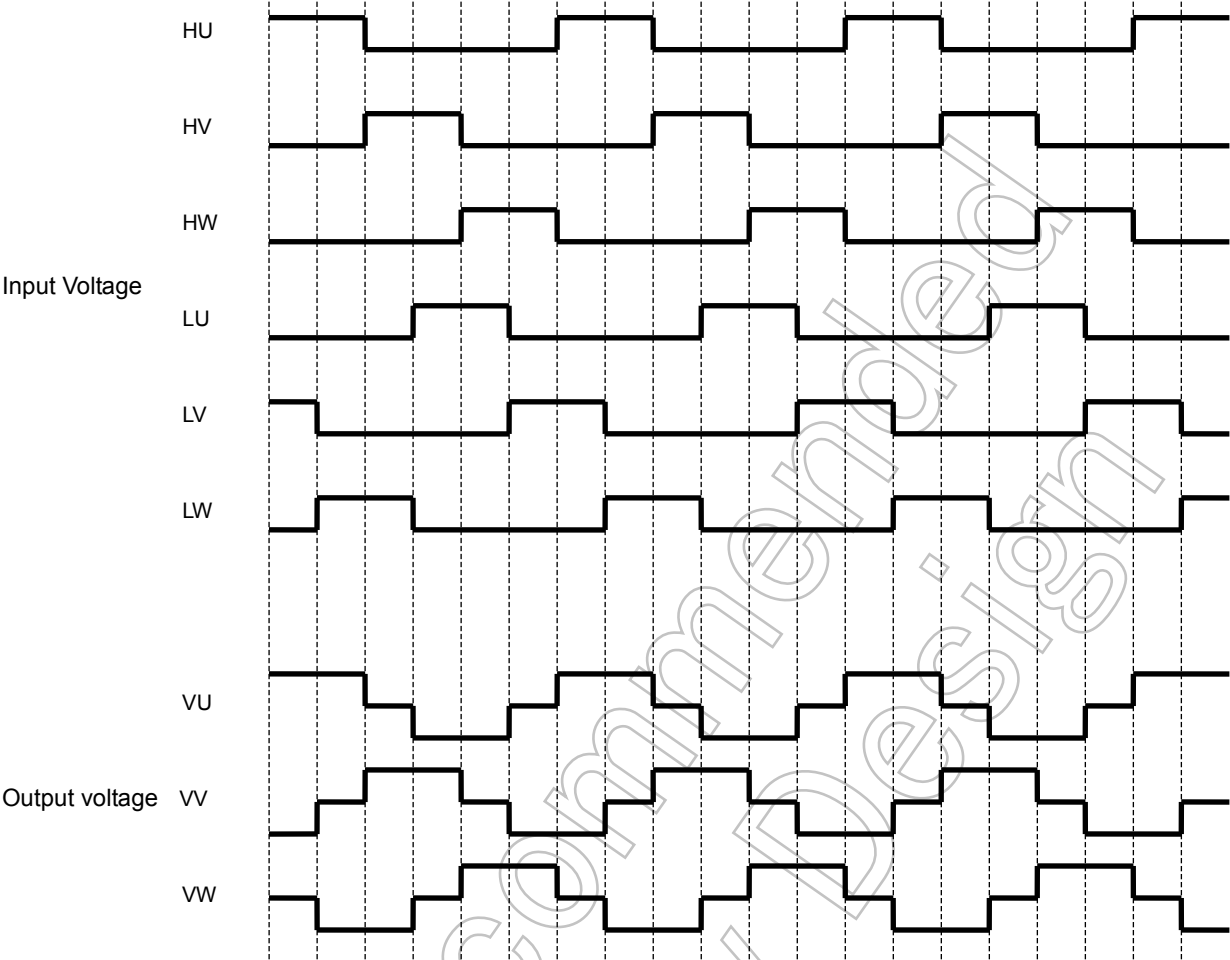

Not Recommended for New Design

## Truth Table

Mode	Input							High side			Low side			DIAG
	HU	HV	HW	LU	LV	LW	SD	U phase	V phase	W phase	U phase	V phase	W phase	
Normal	H	L	L	L	H	L	H	ON	OFF	OFF	OFF	ON	OFF	OFF
	H	L	L	L	L	H	H	ON	OFF	OFF	OFF	OFF	ON	OFF
	L	H	L	L	L	H	H	OFF	ON	OFF	OFF	OFF	ON	OFF
	L	H	L	H	L	L	H	OFF	ON	OFF	ON	OFF	OFF	OFF
	L	L	H	H	L	L	H	OFF	OFF	ON	ON	OFF	OFF	OFF
	L	L	H	L	H	L	H	OFF	OFF	ON	OFF	ON	OFF	OFF
Over-current	H	L	L	L	H	L	H	OFF	OFF	OFF	OFF	OFF	OFF	ON
	H	L	L	L	L	H	H	OFF	OFF	OFF	OFF	OFF	OFF	ON
	L	H	L	L	L	H	H	OFF	OFF	OFF	OFF	OFF	OFF	ON
	L	H	L	H	L	L	H	OFF	OFF	OFF	OFF	OFF	OFF	ON
	L	L	H	H	L	L	H	OFF	OFF	OFF	OFF	OFF	OFF	ON
	L	L	H	L	H	L	H	OFF	OFF	OFF	OFF	OFF	OFF	ON
Thermal shutdown	H	L	L	L	H	L	H	OFF	OFF	OFF	OFF	OFF	OFF	ON
	H	L	L	L	L	H	H	OFF	OFF	OFF	OFF	OFF	OFF	ON
	L	H	L	L	L	H	H	OFF	OFF	OFF	OFF	OFF	OFF	ON
	L	H	L	H	L	L	H	OFF	OFF	OFF	OFF	OFF	OFF	ON
	L	L	H	H	L	L	H	OFF	OFF	OFF	OFF	OFF	OFF	ON
	L	L	H	L	H	L	H	OFF	OFF	OFF	OFF	OFF	OFF	ON
Vcc Under-voltage	H	L	L	L	H	L	H	OFF	OFF	OFF	OFF	OFF	OFF	ON
	H	L	L	L	L	H	H	OFF	OFF	OFF	OFF	OFF	OFF	ON
	L	H	L	L	L	H	H	OFF	OFF	OFF	OFF	OFF	OFF	ON
	L	H	L	H	L	L	H	OFF	OFF	OFF	OFF	OFF	OFF	ON
	L	L	H	H	L	L	H	OFF	OFF	OFF	OFF	OFF	OFF	ON
	L	L	H	L	H	L	H	OFF	OFF	OFF	OFF	OFF	OFF	ON
Vbs Under-voltage	H	L	L	L	H	L	H	OFF	OFF	OFF	OFF	ON	OFF	OFF
	H	L	L	L	L	H	H	OFF	OFF	OFF	OFF	OFF	ON	OFF
	L	H	L	L	L	H	H	OFF	OFF	OFF	OFF	OFF	ON	OFF
	L	H	L	H	L	L	H	OFF	OFF	OFF	ON	OFF	OFF	OFF
	L	L	H	H	L	L	H	OFF	OFF	OFF	ON	OFF	OFF	OFF
	L	L	H	L	H	L	H	OFF	OFF	OFF	OFF	ON	OFF	OFF
Irregular (Note)	H	L	L	H	L	L	H	OFF	OFF	OFF	OFF	OFF	OFF	OFF
	L	H	L	L	H	L	H	OFF	OFF	OFF	OFF	OFF	OFF	OFF
	L	L	H	L	L	H	H	OFF	OFF	OFF	OFF	OFF	OFF	OFF
SD	X	X	X	X	X	X	L	OFF	OFF	OFF	OFF	OFF	OFF	ON

X: Don't care

Note: The output of the input logic is OFF if the high side input and low side input are ON at the same time

## Absolute Maximum Ratings (Ta = 25°C)

Characteristics	Symbol	Rating	Unit
Power supply voltage	V <sub>BB</sub>	500	V
	V <sub>CC</sub>	18	V
Output current (DC)	I <sub>out</sub>	2.5	A
Output current (pulse 100 μs)	I <sub>outp</sub>	3.75	A
Input voltage	V <sub>IN</sub>	-0.5 to 7	V
V <sub>REG</sub> current	I <sub>REG</sub>	50	mA
DIAG voltage	V <sub>DIAG</sub>	20	V
DIAG current	I <sub>DIAG</sub>	20	mA
Power dissipation (All phase (T <sub>c</sub> = 25 °C))	P <sub>C</sub>	3	W
Thermal Resistance (Junction to Case) (Note 1)	R <sub>j-c</sub>	15	°C/W
Operating Case temperature	T <sub>copr</sub>	-40 to 100	°C
Junction temperature	T <sub>j</sub>	150	°C
Storage temperature	T <sub>stg</sub>	-55 to 150	°C

Note 1: Mounted on two layers of JEDEC standard PCB, 76.2 mm × 114.3 mm × 1.6 mm, in still air.

Note: Using continuously under heavy loads (e.g. the application of high temperature/current/voltage and the significant change in temperature, etc.) may cause this product to decrease in the reliability significantly even if the operating conditions (i.e. operating temperature/current/voltage, etc.) are within the absolute maximum ratings and the operating ranges.

Please design the appropriate reliability upon reviewing the Toshiba Semiconductor Reliability Handbook ("Handling Precautions"/"Derating Concept and Methods") and individual reliability data (i.e. reliability test report and estimated failure rate, etc).

## Electrical Characteristics (Ta = 25°C)

Characteristics	Symbol	Test Condition	Min	Typ.	Max	Unit
Operating power supply voltage	V <sub>BB</sub>	—	50	280	450	V
	V <sub>CC</sub>	—	13.5	15	16.5	
Current dissipation	I <sub>BB</sub>	V <sub>BB</sub> = 450 V	—	—	0.5	mA
	I <sub>CC</sub>	V <sub>CC</sub> = 15 V	—	0.8	5	
Bootstrap Current dissipation	I <sub>BS</sub> (ON)	V <sub>BS</sub> = 15 V, high side ON	—	210	410	μA
	I <sub>BS</sub> (OFF)	V <sub>BS</sub> = 15 V, high side OFF	—	180	370	
Input voltage	V <sub>IH</sub>	V <sub>IN</sub> = "H", V <sub>CC</sub> = 15 V	2.5	—	—	V
	V <sub>IL</sub>	V <sub>IN</sub> = "L", V <sub>CC</sub> = 15 V	—	—	1.5	
Input current	I <sub>IH</sub>	V <sub>IN</sub> = 5 V	—	—	150	μA
	I <sub>IL</sub>	V <sub>IN</sub> = 0 V	—	—	100	
SD Input voltage	V <sub>SD</sub>	V <sub>CC</sub> = 15 V	—	2.5	—	V
SD Input current	I <sub>SDH</sub>	V <sub>IN</sub> = 5 V	—	—	100	μA
	I <sub>SDL</sub>	V <sub>IN</sub> = 0 V	—	—	150	
MOSFET Leakage Current	I <sub>DSS</sub>	V <sub>BB</sub> = 500 V	—	—	100	μA
MOSFET On State Resistance	R <sub>DSONH</sub>	V <sub>CC</sub> = 15 V, I <sub>C</sub> = 1.25 A, high side	—	1.7	2.3	Ω
	R <sub>DSONL</sub>	V <sub>CC</sub> = 15 V, I <sub>C</sub> = 1.25 A, low side	—	1.7	2.3	
Diode forward voltage (MOSFET)	V <sub>FH</sub>	I <sub>F</sub> = 1.25 A, high side	—	1	1.7	V
	V <sub>FL</sub>	I <sub>F</sub> = 1.25 A, low side	—	1	1.7	
BSD forward voltage	V <sub>F</sub> (BSD)	I <sub>F</sub> = 500 μA	—	0.8	1.2	V
Regulator voltage	V <sub>REG</sub>	V <sub>CC</sub> = 15 V, I <sub>REG</sub> = 30 mA	6.5	7	7.5	V
Current limiting voltage	V <sub>R</sub>	—	0.46	0.5	0.54	V
Current limiting delay time	D <sub>t</sub>	—	1.5	3	5	μs
Thermal shutdown temperature	T <sub>SD</sub>	V <sub>CC</sub> = 15 V	135	—	185	°C
Thermal shutdown hysteresis	ΔT <sub>SD</sub>	V <sub>CC</sub> = 15 V	—	50	—	°C
V <sub>CC</sub> under voltage protection	V <sub>CCUVD</sub>	—	10	11	12	V
V <sub>CC</sub> under voltage protection recovery	V <sub>CCUVR</sub>	—	10.5	11.5	12.5	V
V <sub>BS</sub> under voltage protection	V <sub>BSUVD</sub>	—	9	10	11	V
V <sub>BS</sub> under voltage protection recovery	V <sub>BSUVR</sub>	—	9.5	10.5	11.5	V
DIAG saturation voltage	V <sub>DIAGsat</sub>	I <sub>DIAG</sub> = 5 mA	—	—	0.5	V
Output on delay time	t <sub>on</sub>	V <sub>BB</sub> = 280 V, V <sub>CC</sub> = 15 V, I <sub>C</sub> = 1.25 A	—	0.9	1.8	μs
Output off delay time	t <sub>off</sub>	V <sub>BB</sub> = 280 V, V <sub>CC</sub> = 15 V, I <sub>C</sub> = 1.25 A	—	1.5	2.4	μs
Dead time	t <sub>dead</sub>	V <sub>BB</sub> = 280 V, V <sub>CC</sub> = 15 V, I <sub>C</sub> = 1.25 A	1.4	—	—	μs
Diode reverse recovery time (MOSFET)	t <sub>rr</sub>	V <sub>BB</sub> = 280 V, V <sub>CC</sub> = 15 V, I <sub>C</sub> = 1.25 A	—	90	—	ns

**Application Circuit Example1: (Operate an overcurrent protection function with a control IC or a microcomputer.)**

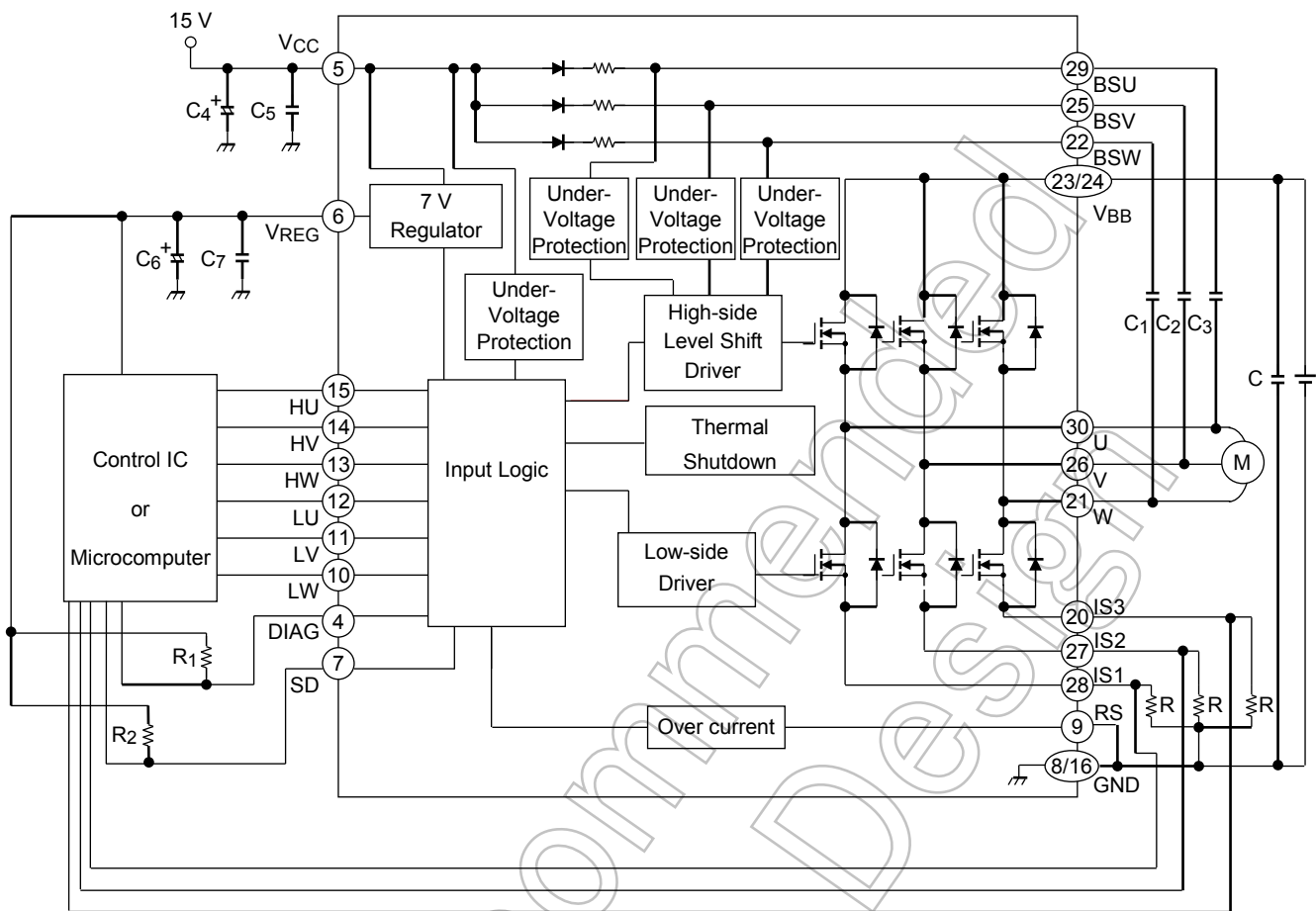

Not Recommended for New

**Application Circuit Example2: (Operate an overcurrent protection function with this product.)**

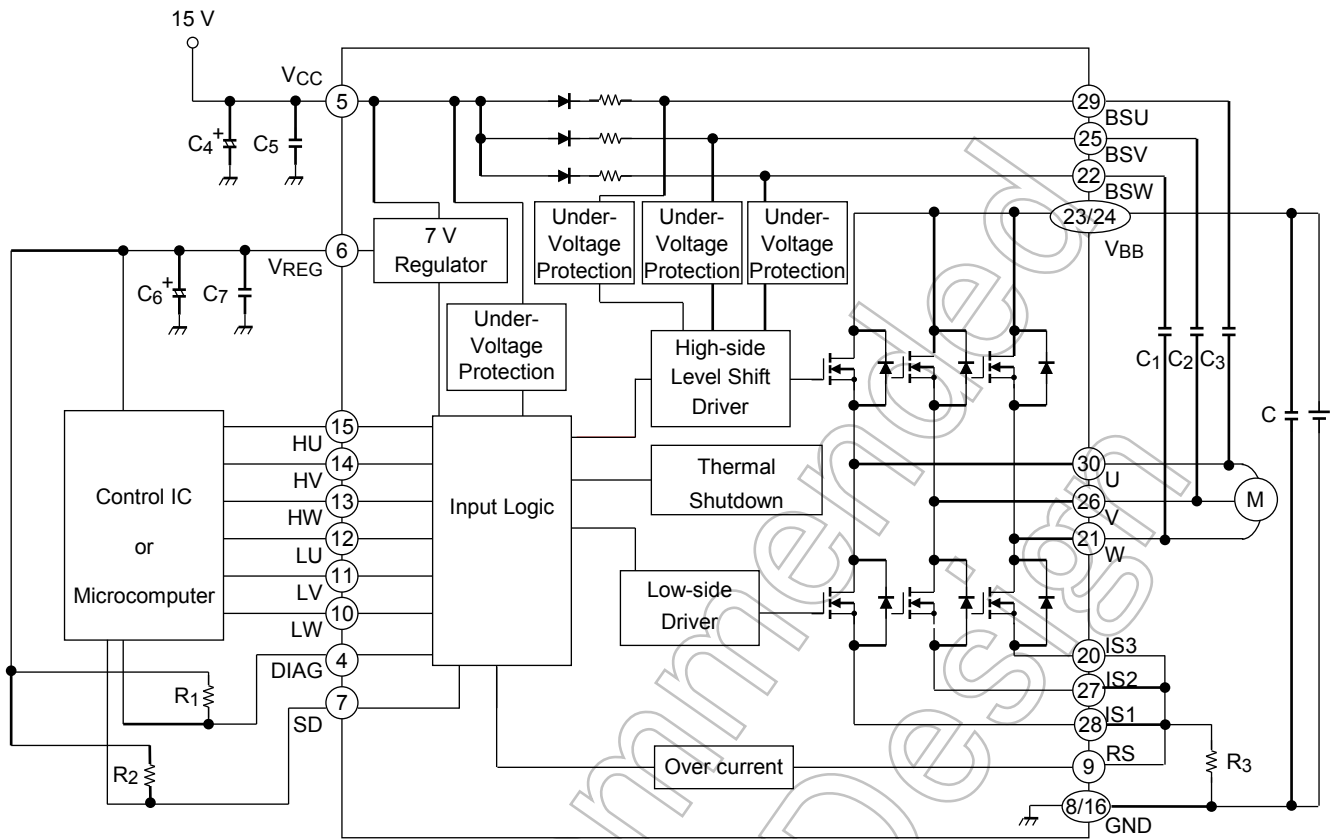

Not Recommended for New

## External Parts

Typical external parts are shown in the following table.

Part	Typical	Purpose	Remarks
C1, C2, C3	25 V/2.2 $\mu$ F	Bootstrap capacitor	(Note 1)
C4	25 V/10 $\mu$ F	VCC power supply stability	(Note 2)
C5	25 V/0.1 $\mu$ F	VCC for surge absorber	(Note 2)
C6	25 V/1 $\mu$ F	VREG power supply stability	(Note 2)
C7	25 V/1000 pF	VREG for surge absorber	(Note 2)
R1	5.1 k $\Omega$	DIAG pull-up resistor	(Note 3)
R2	10 k $\Omega$	SD pull-up resistor	-
R3	0.35 $\Omega$ $\pm$ 1 % (1 W)	Current detection	(Note 4)

Note 1: The required bootstrap capacitance value varies according to the motor drive conditions. The capacitor is biased by VCC and must be sufficiently derated for it.

Note 2: When using this product, adjustment is required in accordance with the use environment. When mounting, place as close to the base of this product leads as possible to improve the ripple and noise elimination.

Note 3: The DIAG pin is open drain. If not using the DIAG pin, connect to the GND.

Note 4: The following formula shows the detection current:  $I_O \cong V_R \div R_3$  (For  $V_R = 0.5$  V (typ.))

### Handling precautions

- (1) Please control the input signal in the state to which the VCC voltage is steady. Both of the order of the VBB power supply and the VCC power supply are not cared about either.  
Note that if the power supply is switched off as described above, this product may be destroyed if the current regeneration route to the VBB power supply is blocked when the VBB line is disconnected by a relay or similar while the motor is still running.
- (2) The RS pin connecting the current detection resistor is connected to a comparator in the IC and also functions as a sensor pin for detecting over current. As a result, over voltage caused by a surge voltage, for example, may destroy the circuit. Accordingly, be careful of handling the IC or of surge voltage in its application environment.

**Description of Protection Function**

- (1) Under voltage protection  
 This product incorporates under voltage protection circuits to prevent the MOSFET from operating in unsaturated mode when the VCC voltage or the VBS voltage drops.  
 When the VCC power supply falls to this product internal setting VCCUVD (= 11 V (typ.)), all MOSFET outputs shut down regardless of the input. This protection function has hysteresis. When the VCC power supply reaches 0.5 V higher than the shutdown voltage (VCCUVR (= 11.5 V (typ.)), this product is automatically restored and the MOSFET is turned on again by the input. DIAG output is reversed at the time of VCC under-voltage protection. When the VCC power supply is less than 7 V, DIAG output isn't sometimes reversed. When the VBS supply voltage drops VBSUVD (= 10 V (typ.)), the high-side MOSFET output shuts down. When the VBS supply voltage reaches 0.5 V higher than the shutdown voltage (VBSUVR (= 10.5 V (typ.)), the MOSFET is turned on again by the input signal.
- (2) Over-current protection  
 This product incorporates an over-current protection circuit to protect itself against over-current at startup or when a motor is locked. This protection function detects voltage generated in the current detection resistor connected to the RS pin. When this voltage exceeds VR (= 0.5 V (typ.)), the MOSFET output, which is on, temporarily shuts down after a delay time, preventing any additional current from flowing to this product. The next all "L" signal releases the shutdown state.
- (3) Thermal shutdown  
 This product incorporates a thermal shutdown circuit to protect itself against the abnormal state when its temperature rises excessively.  
 When the temperature of this chip rises to the internal setting TSD due to external causes or internal heat generation, all MOSFET outputs shut down regardless of the input. This protection function has hysteresis  $\Delta TSD$  (= 50 °C (typ.)). When the chip temperature falls to  $TSD - \Delta TSD$ , the chip is automatically restored and the MOSFET is turned on again by the input.  
 Because the chip contains just one temperature detection location, when the chip heats up due to the MOSFET, for example, the differences in distance from the detection location in the MOSFET (the source of the heat) cause differences in the time taken for shutdown to occur. Therefore, the temperature of the chip may rise higher than the thermal shutdown temperature when the circuit started to operate.
- (4) SD function  
 SD pin is the input signal pin to shut down the internal output MOSFET. Output of all MOSFET is shut down after delay times (2  $\mu$ s (typ.)) when "L" signal is input to the SD pin from external circuit (MCU etc.). It is possible to shut down IC when overcurrent and others is detected by external circuit. Shut down state is released by all of IC input signal "L". At open state of SD pin, shut down function can not operate.

**Timing Chart of Under voltage protection**

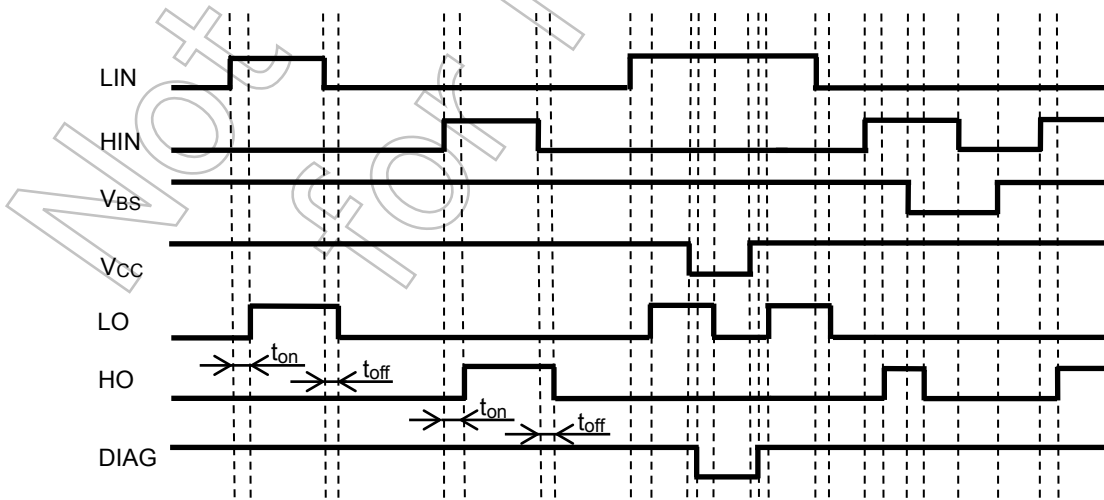

Note: The above timing chart is considering the delay time

**Package Dimensions**

Unit: mm

P-SSOP30-1120-1.00-001

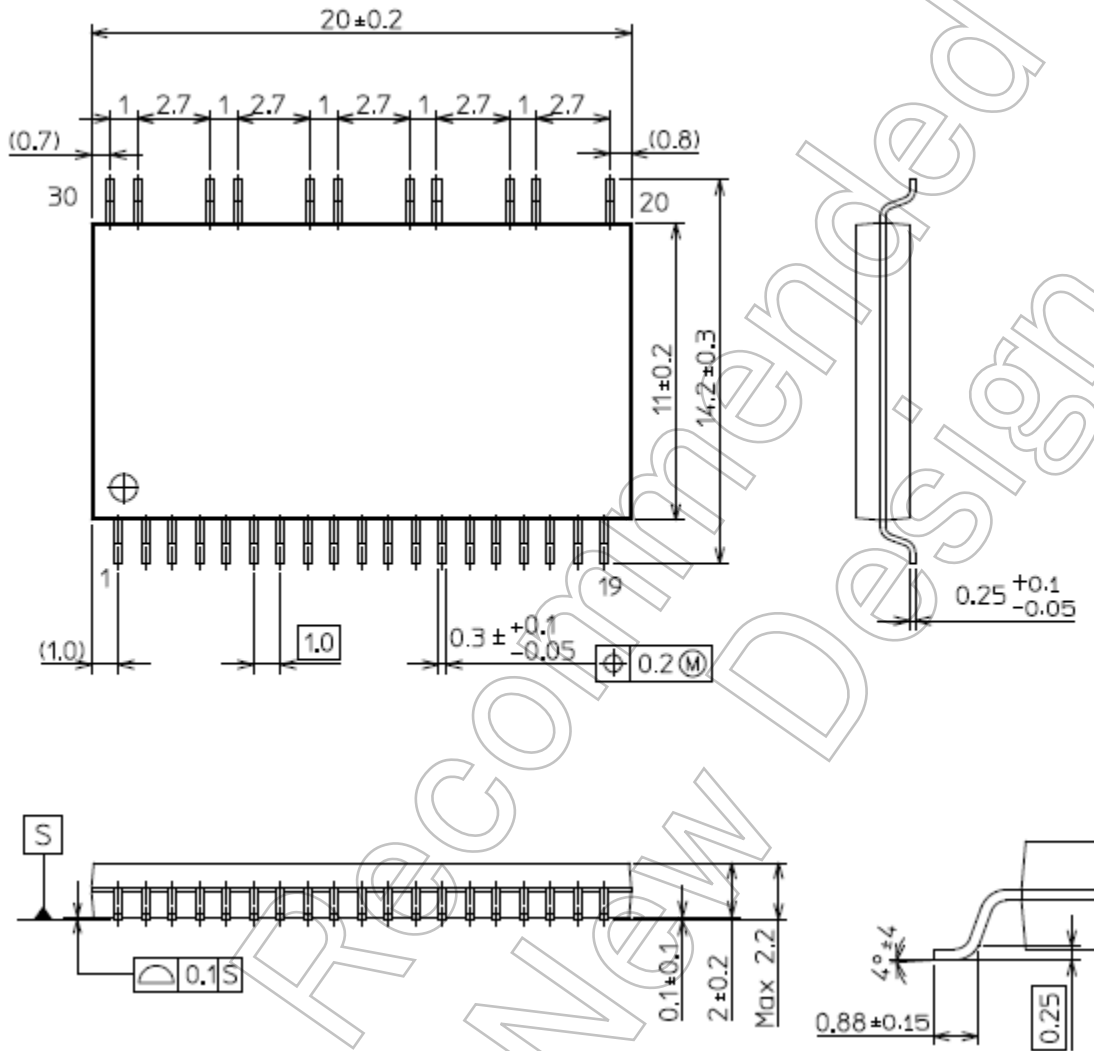

Package Name(s)
TOSHIBA : P-SSOP30-1120-1.00-001
Nickname : SSOP30

## RESTRICTIONS ON PRODUCT USE

Toshiba Corporation and its subsidiaries and affiliates are collectively referred to as "TOSHIBA". Hardware, software and systems described in this document are collectively referred to as "Product".

- TOSHIBA reserves the right to make changes to the information in this document and related Product without notice.
- This document and any information herein may not be reproduced without prior written permission from TOSHIBA. Even with TOSHIBA's written permission, reproduction is permissible only if reproduction is without alteration/omission.
- Though TOSHIBA works continually to improve Product's quality and reliability, Product can malfunction or fail. Customers are responsible for complying with safety standards and for providing adequate designs and safeguards for their hardware, software and systems which minimize risk and avoid situations in which a malfunction or failure of Product could cause loss of human life, bodily injury or damage to property, including data loss or corruption. Before customers use the Product, create designs including the Product, or incorporate the Product into their own applications, customers must also refer to and comply with (a) the latest versions of all relevant TOSHIBA information, including without limitation, this document, the specifications, the data sheets and application notes for Product and the precautions and conditions set forth in the "TOSHIBA Semiconductor Reliability Handbook" and (b) the instructions for the application with which the Product will be used with or for. Customers are solely responsible for all aspects of their own product design or applications, including but not limited to (a) determining the appropriateness of the use of this Product in such design or applications; (b) evaluating and determining the applicability of any information contained in this document, or in charts, diagrams, programs, algorithms, sample application circuits, or any other referenced documents; and (c) validating all operating parameters for such designs and applications. **TOSHIBA ASSUMES NO LIABILITY FOR CUSTOMERS' PRODUCT DESIGN OR APPLICATIONS.**
- **PRODUCT IS NEITHER INTENDED NOR WARRANTED FOR USE IN EQUIPMENTS OR SYSTEMS THAT REQUIRE EXTRAORDINARILY HIGH LEVELS OF QUALITY AND/OR RELIABILITY, AND/OR A MALFUNCTION OR FAILURE OF WHICH MAY CAUSE LOSS OF HUMAN LIFE, BODILY INJURY, SERIOUS PROPERTY DAMAGE AND/OR SERIOUS PUBLIC IMPACT ("UNINTENDED USE").** Except for specific applications as expressly stated in this document, Unintended Use includes, without limitation, equipment used in nuclear facilities, equipment used in the aerospace industry, medical equipment, equipment used for automobiles, trains, ships and other transportation, traffic signaling equipment, equipment used to control combustions or explosions, safety devices, elevators and escalators, devices related to electric power, and equipment used in finance-related fields. **IF YOU USE PRODUCT FOR UNINTENDED USE, TOSHIBA ASSUMES NO LIABILITY FOR PRODUCT.** For details, please contact your TOSHIBA sales representative.
- Do not disassemble, analyze, reverse-engineer, alter, modify, translate or copy Product, whether in whole or in part.
- Product shall not be used for or incorporated into any products or systems whose manufacture, use, or sale is prohibited under any applicable laws or regulations.
- The information contained herein is presented only as guidance for Product use. No responsibility is assumed by TOSHIBA for any infringement of patents or any other intellectual property rights of third parties that may result from the use of Product. No license to any intellectual property right is granted by this document, whether express or implied, by estoppel or otherwise.
- **ABSENT A WRITTEN SIGNED AGREEMENT, EXCEPT AS PROVIDED IN THE RELEVANT TERMS AND CONDITIONS OF SALE FOR PRODUCT, AND TO THE MAXIMUM EXTENT ALLOWABLE BY LAW, TOSHIBA (1) ASSUMES NO LIABILITY WHATSOEVER, INCLUDING WITHOUT LIMITATION, INDIRECT, CONSEQUENTIAL, SPECIAL, OR INCIDENTAL DAMAGES OR LOSS, INCLUDING WITHOUT LIMITATION, LOSS OF PROFITS, LOSS OF OPPORTUNITIES, BUSINESS INTERRUPTION AND LOSS OF DATA, AND (2) DISCLAIMS ANY AND ALL EXPRESS OR IMPLIED WARRANTIES AND CONDITIONS RELATED TO SALE, USE OF PRODUCT, OR INFORMATION, INCLUDING WARRANTIES OR CONDITIONS OF MERCHANTABILITY, FITNESS FOR A PARTICULAR PURPOSE, ACCURACY OF INFORMATION, OR NONINFRINGEMENT.**
- Do not use or otherwise make available Product or related software or technology for any military purposes, including without limitation, for the design, development, use, stockpiling or manufacturing of nuclear, chemical, or biological weapons or missile technology products (mass destruction weapons). Product and related software and technology may be controlled under the applicable export laws and regulations including, without limitation, the Japanese Foreign Exchange and Foreign Trade Law and the U.S. Export Administration Regulations. Export and re-export of Product or related software or technology are strictly prohibited except in compliance with all applicable export laws and regulations.
- Please contact your TOSHIBA sales representative for details as to environmental matters such as the RoHS compatibility of Product. Please use Product in compliance with all applicable laws and regulations that regulate the inclusion or use of controlled substances, including without limitation, the EU RoHS Directive. **TOSHIBA ASSUMES NO LIABILITY FOR DAMAGES OR LOSSES OCCURRING AS A RESULT OF NONCOMPLIANCE WITH APPLICABLE LAWS AND REGULATIONS.**