

TOSHIBA CDMOS Integrated Circuit Silicon Monolithic

TC78H630FNG

DC brushed motors driver IC

The TC78H630FNG is H-bridge driver IC for DC motor which incorporates DMOS in output transistors.

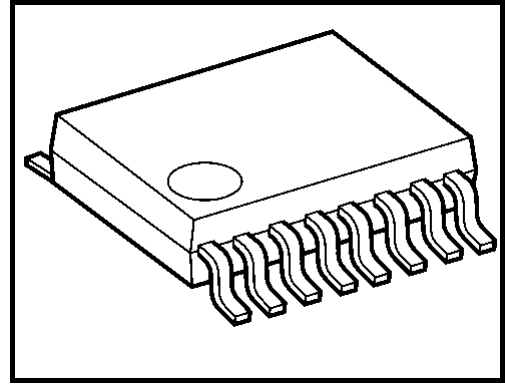

P-TSSOP16-0505-0.65-001 Weight: 0.06 g(Typ.)

Features

- Power supply voltage for motor : $V_M=18$ V(Absolute Maximum Ratings)
- Power supply voltage for control : $V_{CC}=6$ V(Absolute Maximum Ratings)
- Output current : $I_{OUT}=2.1$ A(Absolute Maximum Ratings)
- Output ON resistance : R_{on} (upper and lower sum)= 0.4Ω (Typ.)
- Internal pull-down resistors on inputs : 200 k Ω (Typ.)
- Built-in over current detection(ISD), thermal shutdwon(TSD) circuit, and under voltage lockout(UVLO) circuit.
- Small package : P-TSSOP16-0505-0.65-001
- Built-in cross conduction protection circuit

Block Diagram

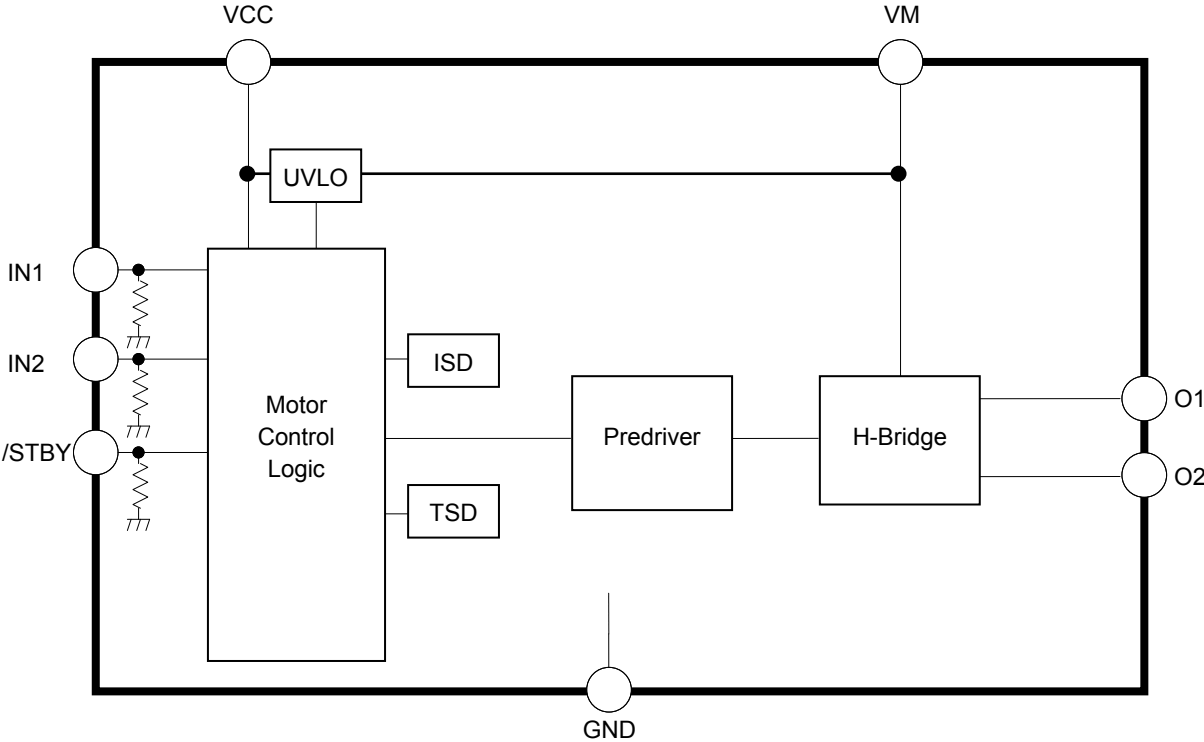

* Please note that in the block diagram, functional blocks or constants may be omitted or simplified for explanatory purposes.

Pin Functions

Pin No.	Pin name	Functional description	Remarks
1	NC	Not connected	Please do not connect any pattern
2	NC	Not connected	Please do not connect any pattern
3	IN2	Control input 2 pin	See the Input/Output functions table.
4	IN1	Control input 1 pin	See the Input/Output functions table.
5	VCC	Power supply pin for logic block	$V_{CC}=2.7$ to 5.5 V
6	/STBY	Standby input	See the Input/Output functions table.
7	NC	Not connected	Please do not connect any pattern
8	NC	Not connected	Please do not connect any pattern
9	VM	Power supply pin for output	$V_M= 2.5$ to 15.0 V
10	GND	Ground pin	
11	O2	Output 2 pin	Please connect with a motor.
12	O2	Output 2 pin	Please connect with a motor.
13	O1	Output 1 pin	Please connect with a motor.
14	O1	Output 1 pin	Please connect with a motor.
15	GND	Ground pin	
16	GND	Ground pin	

* Please connect the pin of the same name near the terminal.

Equivalent Input/Output Circuit

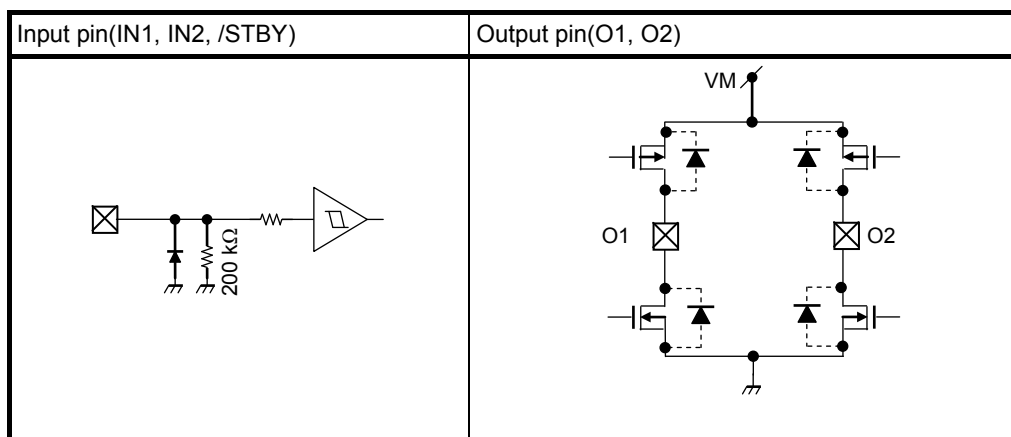

Please note that in the equivalent input/output circuit, functional blocks or constants may be omitted or simplified for explanatory purposes.

Pin Assignment (Top view)

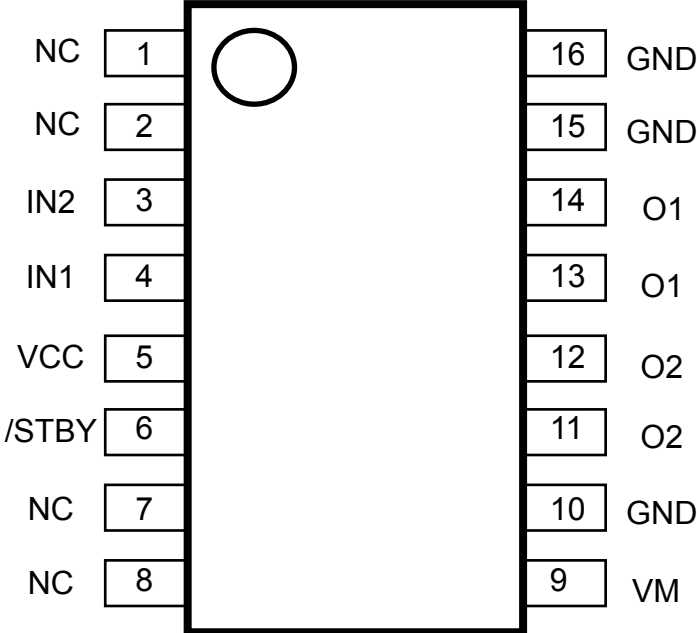

Absolute Maximum Ratings (Ta =25°C)

Characteristics	Symbol	Rating	Unit
Power supply voltage	V _{CC}	6	V
	V _M	18	V
Output current	I _{OUT}	2.1	A
Input voltage	V _{IN}	-0.2 to V _{CC} +0.2	V
Power dissipation	P _D	0.78 (Note1)	W
Operation temperature	T _{opr}	-30 to 85	°C
Storage temperature	T _{stg}	-55 to 150	°C

Note 1: When mounted on a single-side glass epoxy board (50 mm × 50 mm × 1.6 mm, Cu area: 40 %, Cu thick: 35μm)

The absolute maximum ratings of a semiconductor device are a set of specified parameter values that must not be exceeded during operation, even for an instant.

If any of these ratings are exceeded during operation, the electrical characteristics of the device may be irreparably altered, in which case the reliability and lifetime of the device can no longer be guaranteed.

Moreover, any exceeding of the ratings during operation may cause breakdown, damage and/or degradation in other equipment. Applications using the device should be designed so that no absolute maximum ratings will ever be exceeded under any operating condition.

Operating Range (Ta = -30 to 85°C)

Characteristics	Symbol	Conditions	Min	Typ.	Max	Unit
Controlled power supply voltage	V _{CC}	—	2.7	3.3	5.5	V
Motor power supply voltage	V _M	—	2.5	5	15	V
Output current	I _{OUT}	—	—	—	1.6	A
Input voltage	V _{IN}	—	—	—	5.5	V
Control logic frequency	f _{PWM}	IN1, IN2 Duty50% condition	1	—	500	kHz

Maximum current is limited by power dissipation. It depends on the ambient temperature, excitation mode, and heat radiation of the board. Determine a realistic maximum current by calculating the heat generated under the operating environment.

Electrical Characteristics (Ta=25°C, V_{CC}=3.3 V, V_M=5 V, unless otherwise specified.)

Characteristics		Symbol	Test Condition	Min	Typ.	Max	Unit
Input voltage		V _{IN(H)}	IN1, IN2, /STBY	2.0	—	5.5	V
		V _{IN(L)}		-0.2	—	0.8	V
Hysteresis voltage		V _{IN(HYS)}	IN1, IN2, /STBY	—	200	—	mV
Input current		I _{IN(H)}	V _{IN} = 3.3 V	11	16.5	22	μA
		I _{IN(L)}	V _{IN} = 0.8 V	2	4	8	μA
Consumption current		I _{CC1}	Stop mode IN1 = IN2 = L	—	0.5	1	mA
		I _{CC2}	Forward/Reverse mode IN1 = L, IN2 = H	—	0.5	1	mA
		I _{CC3}	Standby mode /STBY=L	—	0	1	μA
		I _{M1}	Stop mode IN1 = IN2 = L	—	0.25	1	mA
		I _{M2}	Forward/Reverse mode IN1 = L, IN2 = H	—	0.25	1	mA
		I _{M3}	Standby mode /STBY=L	—	0	1	μA
Drain-source ON-resistance (The sum of high side & low side)		R _{ON(U+L)}	I _{OUT} = 0.2 A	—	0.4	0.8	Ω
			I _{OUT} = 0.6 A	—	0.4	0.8	
Diode forward voltage		V _{FU}	I _{OUT} = 0.6 A	—	1	1.2	V
		V _{FL}		—	1	1.2	
Output leakage current	Upper	I _{OH}	V _M =15 V	—	—	1	μA
	Lower	I _{OL}		—	—	1	

(Reference) $P_D - T_a$ characteristics

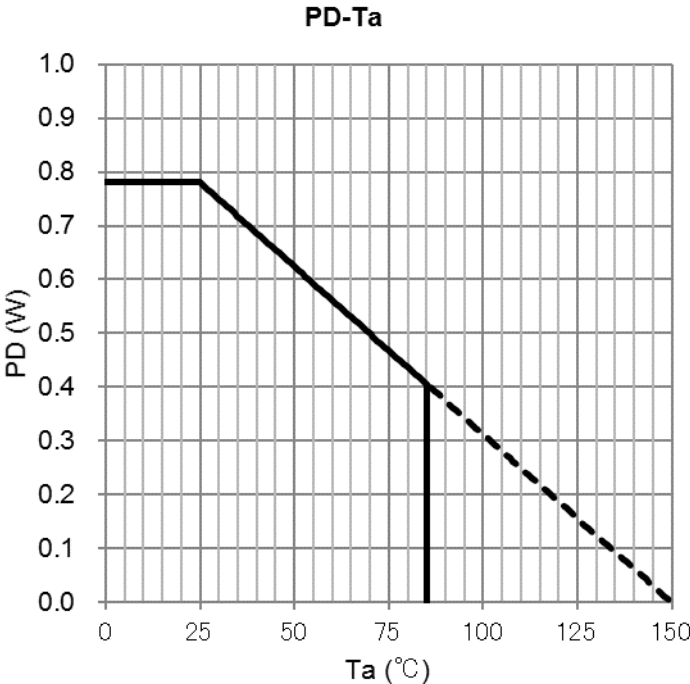

When mounted on a single-side glass epoxy board (50 mm × 50 mm × 1.6 mm, Cu area: 40 %, Cu thick: 35μm)

* The above characteristics is a reference value and is not a guaranteed.

Input/Output functions

/STBY	Input		Output		Mode
	IN1	IN2	O1	O2	
H	H	H	L	L	Short brake
H	L	H	L	H	Forward/Reverse
H	H	L	H	L	Reverse/Forward
H	L	L	OFF (High impedance)		Stop
L	—	—	OFF (High impedance)		Standby

Output waveform timing chart (voltage waveform)

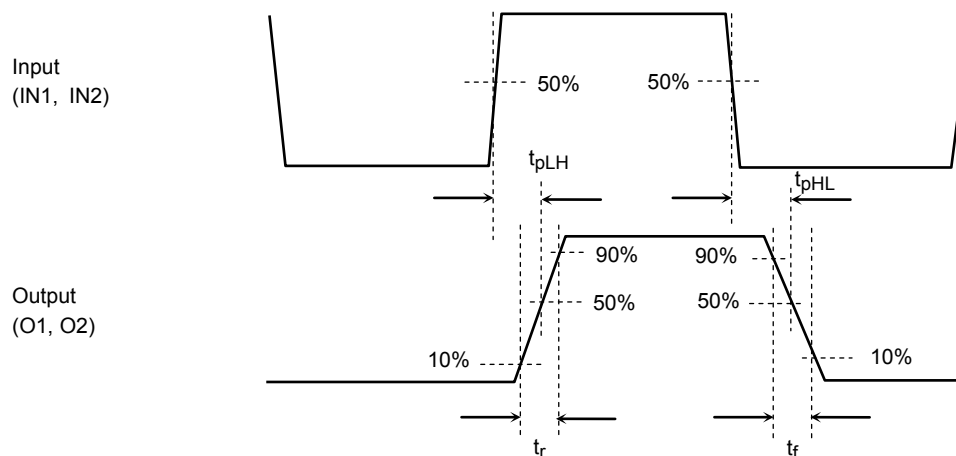

AC Electrical characteristics (Reference)

Symbol	Typical value	Unit
t_{pLH}	500	ns
t_{pHL}	500	
t_r	20	
t_f	20	

* The above characteristics is a reference value and is not a guaranteed.

Timing charts may be simplified for explanatory purpose.

Explanation of operation to H-Bridge

To prevent shoot-through current caused by simultaneous conduction of upper and lower transistors in the output stage, a dead time is internally generated when switching the upper and lower transistors. Therefore, synchronous rectification for high efficiency in control can be achieved without an off-time that is generated via an external input.

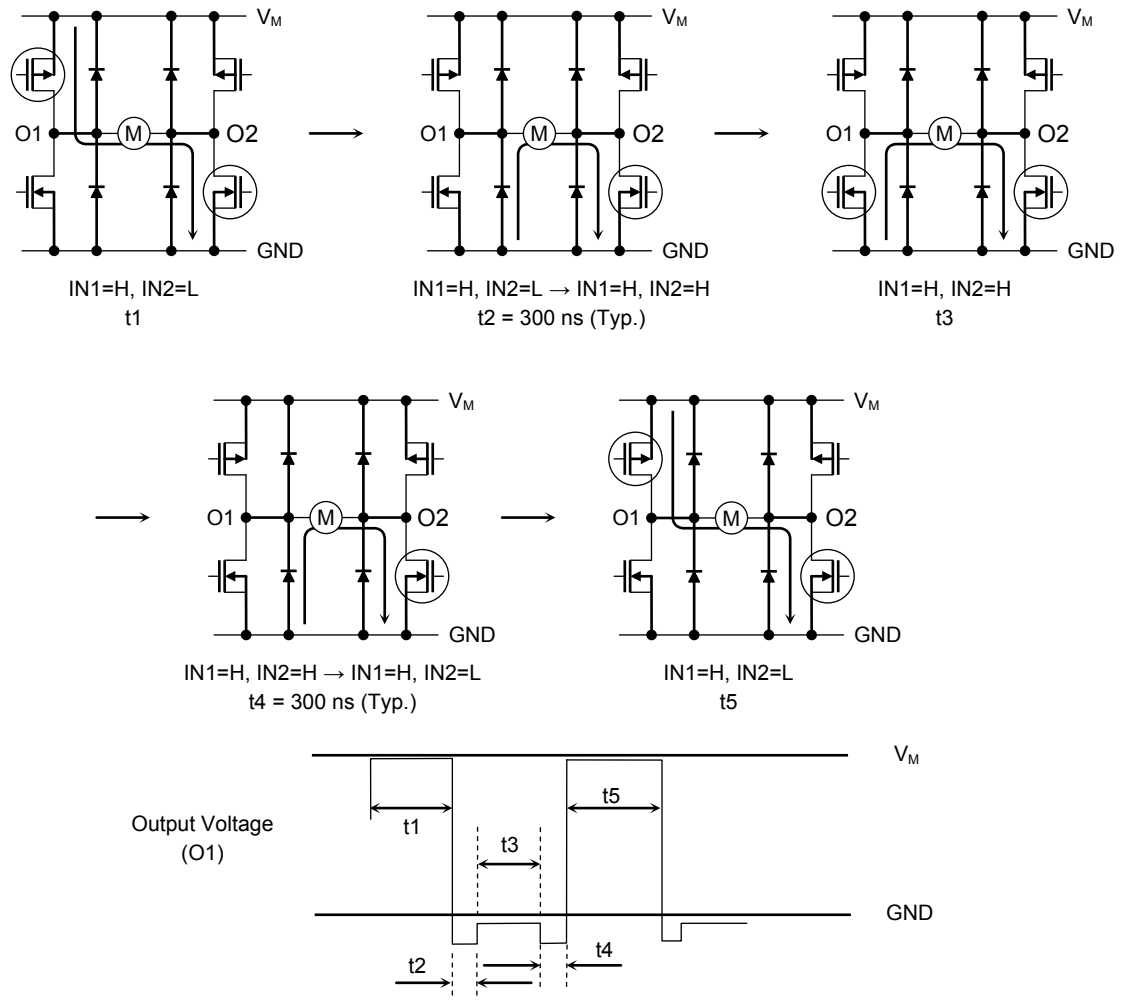

A dead time ($t2, t4$) is a reference value.

TSD (Thermal shut down)

When the junction temperature (T_j) exceeds 170°C (typ.), all outputs are turned off. In the operating state of TSD, IC becomes stop mode (It is the same as the state of IN1/IN2=L conditions).

When the junction temperature (T_j) falls by 40°C(typ.) or more, it returns to the normal mode.

* The operative temperature and release temperature of the TSD are a reference value, and are not a guaranteed performance.

ISD (Over current detection)

When any of current which flows in output transistors exceeds 3.4 A (typ.), all outputs are turned off. In the operating state of ISD, IC becomes stop mode (It is the same as the state of IN1/IN2=L conditions).

However, masking time of 4 μ s (typ.) should be added in order to avoid detection error by the noise.

The output transistors are turned on when one of the following controls is performed.

1. Re-turn on power supply
2. After setting to standby mode (/STBY = L), it sets to operational mode again.

* The actuating current and masking term of the ISD are a reference value, and are not a guaranteed value.

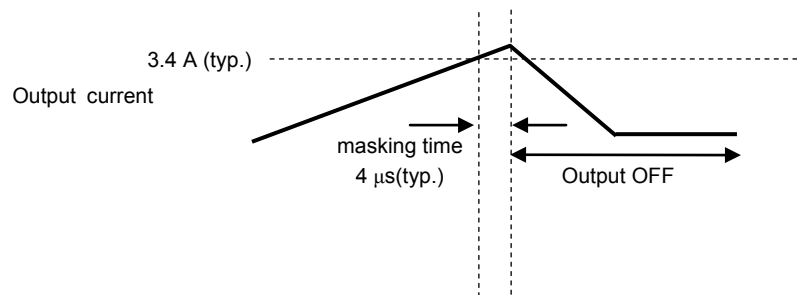

UVLO (Under voltage lockout)

When V_{CC} falls to less than 2.2 V (typ.), all outputs are turned off. In the operating state of UVLO, IC becomes stop mode (It is the same as the state of IN1/IN2=L conditions). By raising V_{CC} more than 2.3 V (typ.), it returns to the normal mode.

When V_M falls to less than 2.0 V (typ.), all outputs are turned off. In the operating state of UVLO, IC becomes stop mode (It is the same as the state of IN1/IN2=L conditions). By raising V_M more than 2.1 V (typ.), it returns to the normal mode.

* The operating voltage and release voltage of the UVLO are a reference value, and are not a guaranteed value.

Application circuit

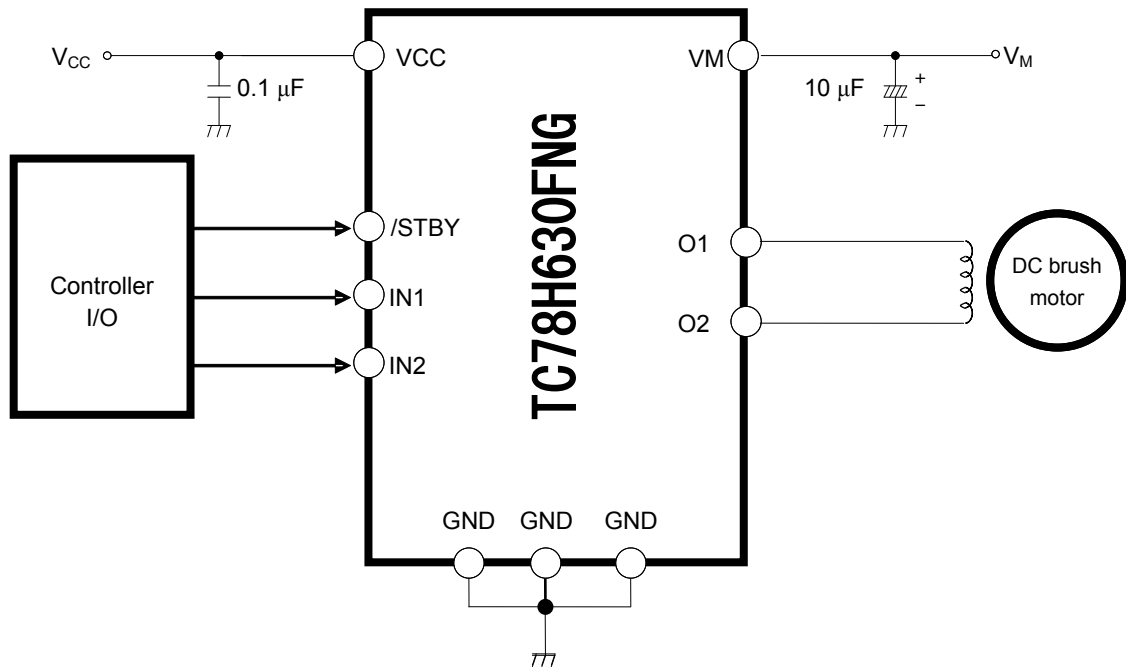

Note 1: A power supply capacitor should be connected as close as possible to the IC.

Note 2: Please set “IN1 and IN2” or “/STBY” as “L” at the time of power supply ON and OFF. If power supply ON and OFF is carried out in the state of H setup, unexpected current may be flown in the output pin depending on the situation.

Caution for using

Utmost care is necessary in the design of the output, VCC, and GND lines since the IC may be destroyed by short-circuiting between outputs, air contamination faults, or faults due to improper grounding, or by short-circuiting between contiguous pins.

Especially, power supply pins (VCC, VM) and output pins (O1, O2) might destroy the IC and the peripheral parts, cause smoke and ignition, and also do injury when they short-circuit an adjacent pin and other pins.

The IC may be destroyed when mounted in the wrong orientation. Thus, please mount it with great care. Please use the power supply fuse.

Package Dimensions

P-TSSOP16-0505-0.65-001

"Unit:mm"

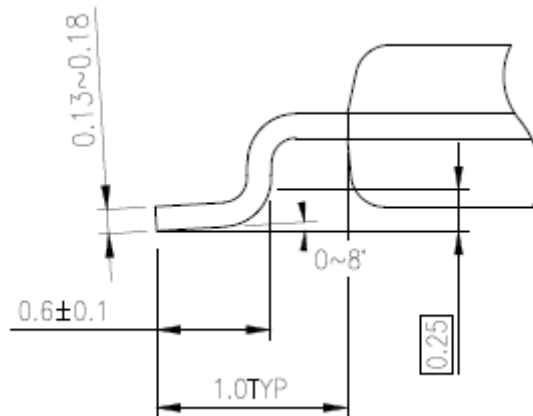
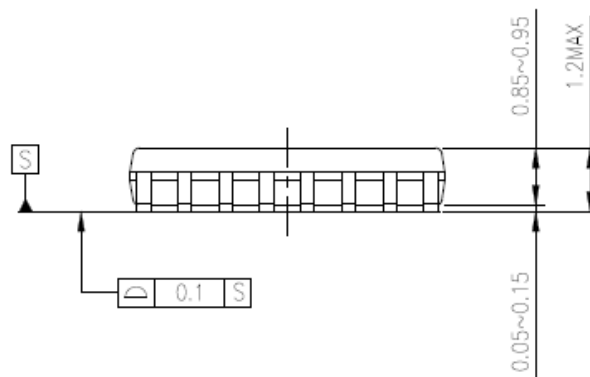
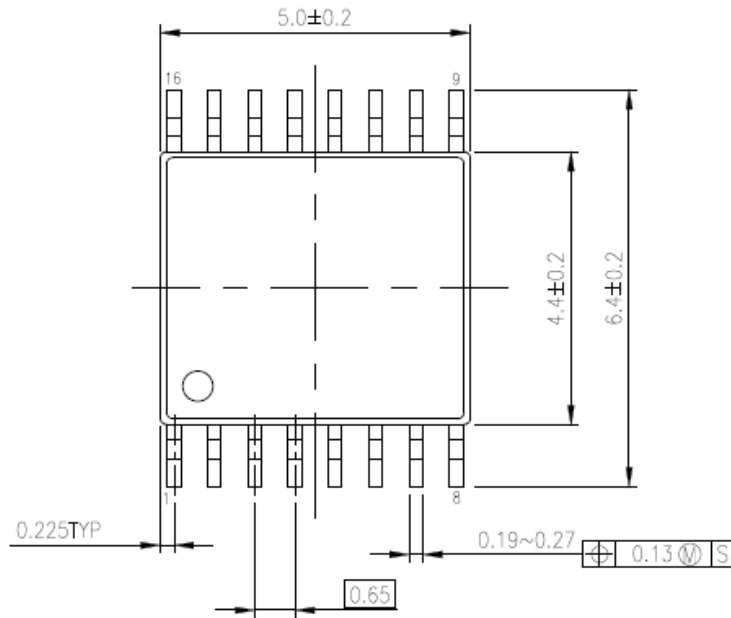

Weight: 0.06 g (typ.)

Notes on Contents

1. Block Diagrams

Some of the functional blocks, circuits, or constants in the block diagram may be omitted or simplified for explanatory purposes.

2. Equivalent Circuits

The equivalent circuit diagrams may be simplified or some parts of them may be omitted for explanatory purposes.

3. Timing Charts

Timing charts may be simplified for explanatory purposes.

4. Application Circuits

The application circuits shown in this document are provided for reference purposes only. Thorough evaluation is required, especially at the mass production design stage.

Toshiba does not grant any license to any industrial property rights by providing these examples of application circuits.

5. Test Circuits

Components in the test circuits are used only to obtain and confirm the device characteristics. These components and circuits are not guaranteed to prevent malfunction or failure from occurring in the application equipment.

IC Usage Considerations

Notes on handling of ICs

- [1] The absolute maximum ratings of a semiconductor device are a set of ratings that must not be exceeded, even for a moment. Do not exceed any of these ratings.
Exceeding the rating(s) may cause the device breakdown, damage or deterioration, and may result injury by explosion or combustion.
- [2] Use an appropriate power supply fuse to ensure that a large current does not continuously flow in case of over current and/or IC failure. The IC will fully break down when used under conditions that exceed its absolute maximum ratings, when the wiring is routed improperly or when an abnormal pulse noise occurs from the wiring or load, causing a large current to continuously flow and the breakdown can lead smoke or ignition. To minimize the effects of the flow of a large current in case of breakdown, appropriate settings, such as fuse capacity, fusing time and insertion circuit location, are required.
- [3] If your design includes an inductive load such as a motor coil, incorporate a protection circuit into the design to prevent device malfunction or breakdown caused by the current resulting from the inrush current at power ON or the negative current resulting from the back electromotive force at power OFF. IC breakdown may cause injury, smoke or ignition.
Use a stable power supply with ICs with built-in protection functions. If the power supply is unstable, the protection function may not operate, causing IC breakdown. IC breakdown may cause injury, smoke or ignition.
- [4] Do not insert devices in the wrong orientation or incorrectly.
Make sure that the positive and negative terminals of power supplies are connected properly.
Otherwise, the current or power consumption may exceed the absolute maximum rating, and exceeding the rating(s) may cause the device breakdown, damage or deterioration, and may result injury by explosion or combustion.
In addition, do not use any device that is applied the current with inserting in the wrong orientation or incorrectly even just one time.

Points to remember on handling of ICs**(1) Over current Protection Circuit**

Over current protection circuits (referred to as current limiter circuits) do not necessarily protect ICs under all circumstances. If the over current protection circuits operate against the over current, clear the over current status immediately.

Depending on the method of use and usage conditions, such as exceeding absolute maximum ratings can cause the over current protection circuit to not operate properly or IC breakdown before operation. In addition, depending on the method of use and usage conditions, if over current continues to flow for a long time after operation, the IC may generate heat resulting in breakdown.

(2) Thermal Shutdown Circuit

Thermal shutdown circuits do not necessarily protect ICs under all circumstances. If the thermal shutdown circuits operate against the over temperature, clear the heat generation status immediately.

Depending on the method of use and usage conditions, such as exceeding absolute maximum ratings can cause the thermal shutdown circuit to not operate properly or IC breakdown before operation.

(3) Heat Radiation Design

In using an IC with large current flow such as power amp, regulator or driver, please design the device so that heat is appropriately radiated, not to exceed the specified junction temperature (T_j) at any time and condition. These ICs generate heat even during normal use. An inadequate IC heat radiation design can lead to decrease in IC life, deterioration of IC characteristics or IC breakdown. In addition, please design the device taking into consideration the effect of IC heat radiation with peripheral components.

(4) Back-EMF

When a motor rotates in the reverse direction, stops or slows down abruptly, a current flow back to the motor's power supply due to the effect of back-EMF. If the current sink capability of the power supply is small, the device's motor power supply and output pins might be exposed to conditions beyond absolute maximum ratings. To avoid this problem, take the effect of back-EMF into consideration in system design.

RESTRICTIONS ON PRODUCT USE

- Toshiba Corporation, and its subsidiaries and affiliates (collectively "TOSHIBA"), reserve the right to make changes to the information in this document, and related hardware, software and systems (collectively "Product") without notice.
- This document and any information herein may not be reproduced without prior written permission from TOSHIBA. Even with TOSHIBA's written permission, reproduction is permissible only if reproduction is without alteration/omission.
- Though TOSHIBA works continually to improve Product's quality and reliability, Product can malfunction or fail. Customers are responsible for complying with safety standards and for providing adequate designs and safeguards for their hardware, software and systems which minimize risk and avoid situations in which a malfunction or failure of Product could cause loss of human life, bodily injury or damage to property, including data loss or corruption. Before customers use the Product, create designs including the Product, or incorporate the Product into their own applications, customers must also refer to and comply with (a) the latest versions of all relevant TOSHIBA information, including without limitation, this document, the specifications, the data sheets and application notes for Product and the precautions and conditions set forth in the "TOSHIBA Semiconductor Reliability Handbook" and (b) the instructions for the application with which the Product will be used with or for. Customers are solely responsible for all aspects of their own product design or applications, including but not limited to (a) determining the appropriateness of the use of this Product in such design or applications; (b) evaluating and determining the applicability of any information contained in this document, or in charts, diagrams, programs, algorithms, sample application circuits, or any other referenced documents; and (c) validating all operating parameters for such designs and applications. **TOSHIBA ASSUMES NO LIABILITY FOR CUSTOMERS' PRODUCT DESIGN OR APPLICATIONS.**
- **PRODUCT IS NEITHER INTENDED NOR WARRANTED FOR USE IN EQUIPMENTS OR SYSTEMS THAT REQUIRE EXTRAORDINARILY HIGH LEVELS OF QUALITY AND/OR RELIABILITY, AND/OR A MALFUNCTION OR FAILURE OF WHICH MAY CAUSE LOSS OF HUMAN LIFE, BODILY INJURY, SERIOUS PROPERTY DAMAGE AND/OR SERIOUS PUBLIC IMPACT ("UNINTENDED USE").** Except for specific applications as expressly stated in this document, Unintended Use includes, without limitation, equipment used in nuclear facilities, equipment used in the aerospace industry, Class 3 medical devices, equipment used for automobiles, and military vehicles and munitions. **IF YOU USE PRODUCT FOR UNINTENDED USE, TOSHIBA ASSUMES NO LIABILITY FOR PRODUCT.** For details, please contact your TOSHIBA sales representative or contact us via our website.
- Do not disassemble, analyze, reverse-engineer, alter, modify, translate or copy Product, whether in whole or in part.
- Product shall not be used for or incorporated into any products or systems whose manufacture, use, or sale is prohibited under any applicable laws or regulations.
- The information contained herein is presented only as guidance for Product use. No responsibility is assumed by TOSHIBA for any infringement of patents or any other intellectual property rights of third parties that may result from the use of Product. No license to any intellectual property right is granted by this document, whether express or implied, by estoppel or otherwise.
- **ABSENT A WRITTEN SIGNED AGREEMENT, EXCEPT AS PROVIDED IN THE RELEVANT TERMS AND CONDITIONS OF SALE FOR PRODUCT, AND TO THE MAXIMUM EXTENT ALLOWABLE BY LAW, TOSHIBA (1) ASSUMES NO LIABILITY WHATSOEVER, INCLUDING WITHOUT LIMITATION, INDIRECT, CONSEQUENTIAL, SPECIAL, OR INCIDENTAL DAMAGES OR LOSS, INCLUDING WITHOUT LIMITATION, LOSS OF PROFITS, LOSS OF OPPORTUNITIES, BUSINESS INTERRUPTION AND LOSS OF DATA, AND (2) DISCLAIMS ANY AND ALL EXPRESS OR IMPLIED WARRANTIES AND CONDITIONS RELATED TO SALE, USE OF PRODUCT, OR INFORMATION, INCLUDING WARRANTIES OR CONDITIONS OF MERCHANTABILITY, FITNESS FOR A PARTICULAR PURPOSE, ACCURACY OF INFORMATION, OR NONINFRINGEMENT.**
- Do not use or otherwise make available Product or related software or technology for any military purposes, including without limitation, for the design, development, use, stockpiling or manufacturing of nuclear, chemical, or biological weapons or missile technology products (mass destruction weapons). Product and related software and technology may be controlled under the applicable export laws and regulations including, without limitation, the Japanese Foreign Exchange and Foreign Trade Law and the U.S. Export Administration Regulations. Export and re-export of Product or related software or technology are strictly prohibited except in compliance with all applicable export laws and regulations.
- Please contact your TOSHIBA sales representative for details as to environmental matters such as the RoHS compatibility of Product. Please use Product in compliance with all applicable laws and regulations that regulate the inclusion or use of controlled substances, including without limitation, the EU RoHS Directive. **TOSHIBA ASSUMES NO LIABILITY FOR DAMAGES OR LOSSES OCCURRING AS A RESULT OF NONCOMPLIANCE WITH APPLICABLE LAWS AND REGULATIONS.**