

TC78H630FNG

Usage considerations

Summary

The TC78H630FNG is dual bridge driver IC.
It can control one DC motor.

Contents

Summary	1
1. Power supply voltage.....	3
1.1 Power supply voltage and usage range	3
1.2 Power supply sequence	3
2. Motor current	3
3. Control input	3
4. Power consumption	4
5. Application circuit example.....	5
6. I/O function	7
7. Protection function	8
8. Drive of bipolar type stepping motor with two TC78H630FNG.....	9
9. Reference foot pattern example	10
Notes on Contents	11
IC Usage Considerations	11
RESTRICTIONS ON PRODUCT USE	13

1. Power supply voltage

1.1 Power supply voltage and usage range

In using the TC78H630FNG, the voltage should be applied to the VM and VCC pins. The maximum rating of VM supply voltage is 18 V. Usage range of the power supply is 2.5 to 15 V.

The maximum rating of VCC voltage is 6 V. Usage range of the voltage is 2.7 to 5.5 V.

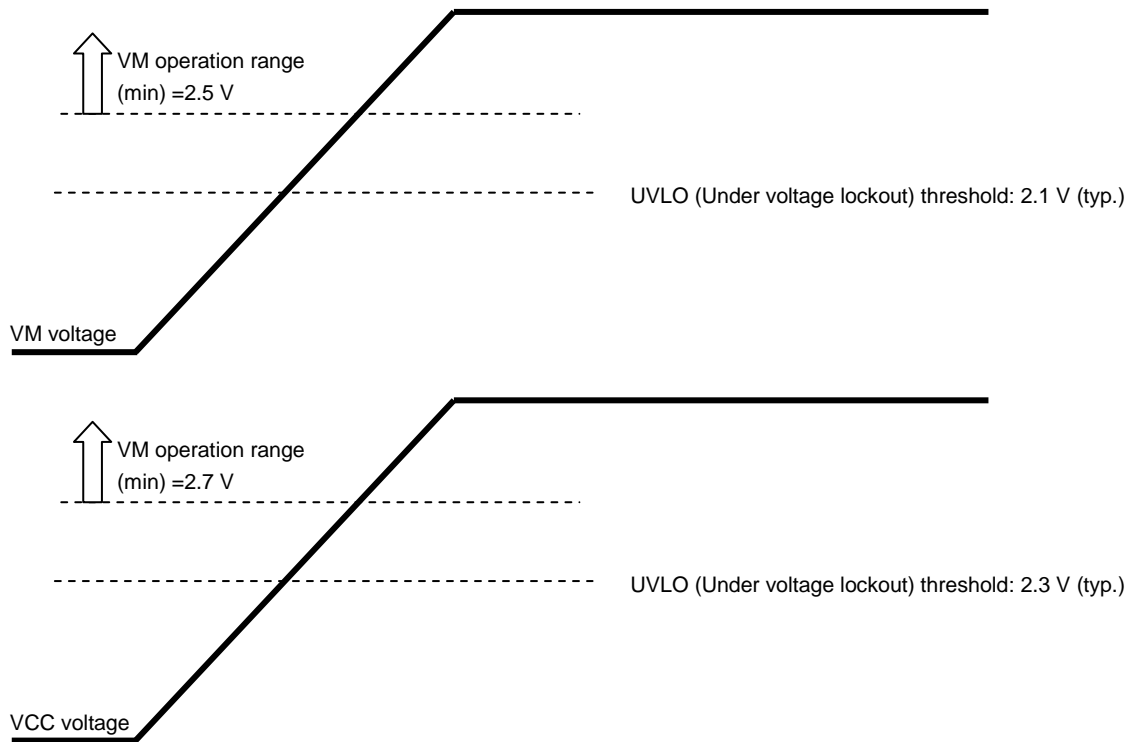

1.2 Power supply sequence

There are no special procedures of inputting a power supply and shutdown because the TC78H630FNG incorporates the under voltage lockout circuit (UVLO). However, under the unstable state of inputting the power supply (VM/VCC) and shutdown, it is recommended to turn off the motor operation. Please operate the motor by switching the input signal after the power supply becomes in the stable state.

2. Motor current

Please configure the motor current 1.6 A or less. Also, note that the peak current may be limited due to usage conditions (ambient temperature, PCB layout pattern, heat issue, step resolution setting, etc.). Please evaluate and check if the device can operate at the required conditions.

3. Control input

Even if the logic signal is inputted when VM voltage is not applied, electromotive force does not generate. But, for safe use, please see the '1.2 Power supply sequence' for reference, and set the input signals to Low before power supply.

4. Power consumption

The power consumption is mainly consumed by the output stage MOSFET and the logic block.

$$P_D (\text{total}) = P_D (\text{out}) + P_D (\text{bias})$$

- **Power consumption of the output stage MOSFET**

The power consumption of the output stage ($P_D (\text{out})$) is calculated from following formula.

$$P_D (\text{out}) = \text{Number of driving H-Bridge} \times I_{\text{out}} (\text{A}) \times I_{\text{out}} (\text{A}) \times R_{\text{on}} (\Omega)$$

In case of driving one DC motor, $R_{\text{on}} = 0.4 \Omega$, and $I_{\text{out}} = 1.0 \text{ A}$, following equation is gained.

$$P_D (\text{out}) = 1.0 (\text{A}) \times 1.0 (\text{A}) \times 0.4 (\Omega) = 0.4 (\text{W})$$

- **Power consumption of the logic block**

The power consumption of the logic block ($P_D (\text{bias})$) is calculated from following formula.

$$P_D (\text{bias}) = V_{\text{CC}} (\text{V}) \times I_{\text{CC}} (\text{A}) + V_{\text{M}} (\text{V}) \times I_{\text{M}} (\text{A})$$

When $V_{\text{M}} = 5 \text{ V}$ and $V_{\text{CC}} = 5 \text{ V}$, following equation is gained.

$$P_D (\text{bias}) = 5 (\text{V}) \times 0.0005 (\text{A}) + 5 (\text{V}) \times 0.00025 (\text{A}) = 0.001 (\text{W})$$

Total power consumption ($P_D (\text{total})$) is calculated as follows;

$$P_D (\text{total}) = P_D (\text{out}) + P_D (\text{bias}) = 0.4 (\text{W}) + 0.001 (\text{W}) = 0.401 (\text{W})$$

The relation of the ambient temperature and the power dissipation in mounting on the board is shown in the following figure. Please design heat dissipation with enough margin after evaluating the thermal design for the board by referring to the above calculated values.

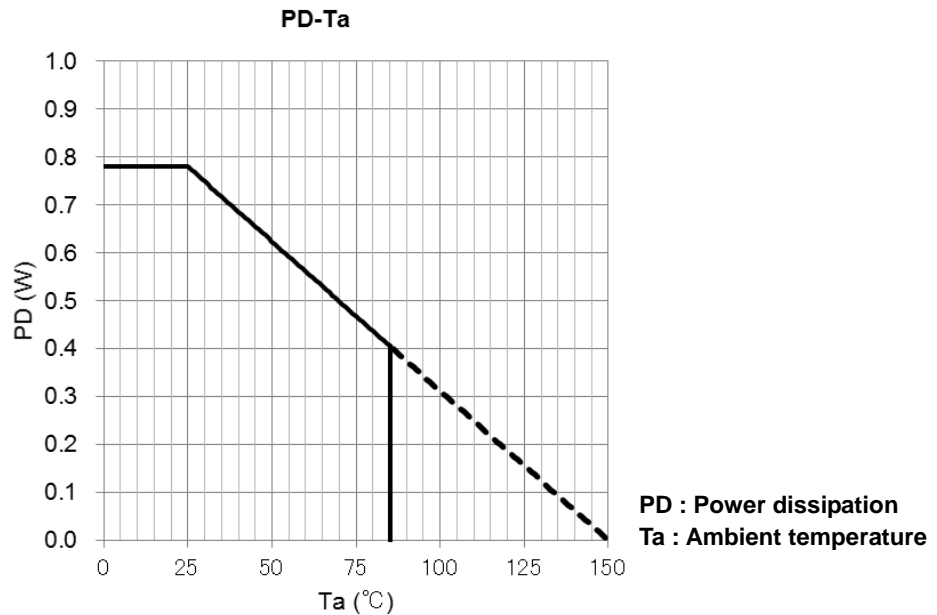

When mounted on a glass epoxy board (50 mm × 50 mm × 1.6 mm, Cu area: 40 %, Cu thick: 35 μm)

5. Application circuit example

DC motor

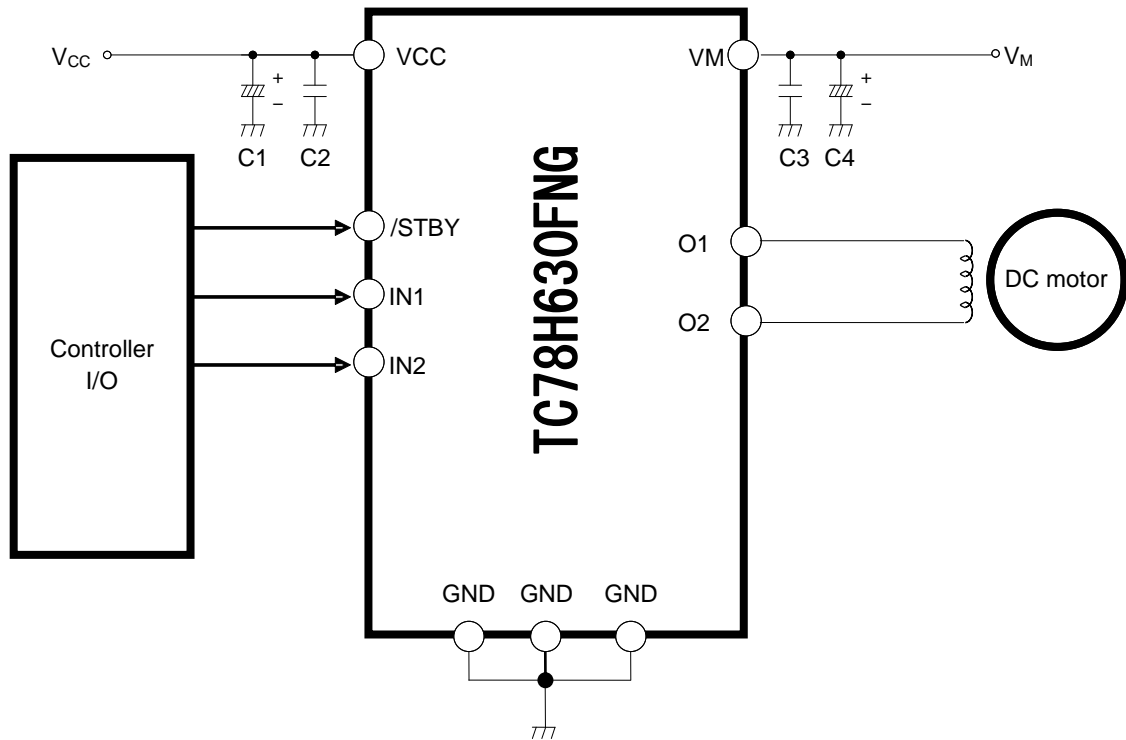

All the grounding wires of the device must run on the solder mask on the PCB and be externally terminated at only one point.

The application circuits shown in this document are provided for reference purposes only. Thorough evaluation is required, especially at the mass production design stage.

Bipolar stepping motor

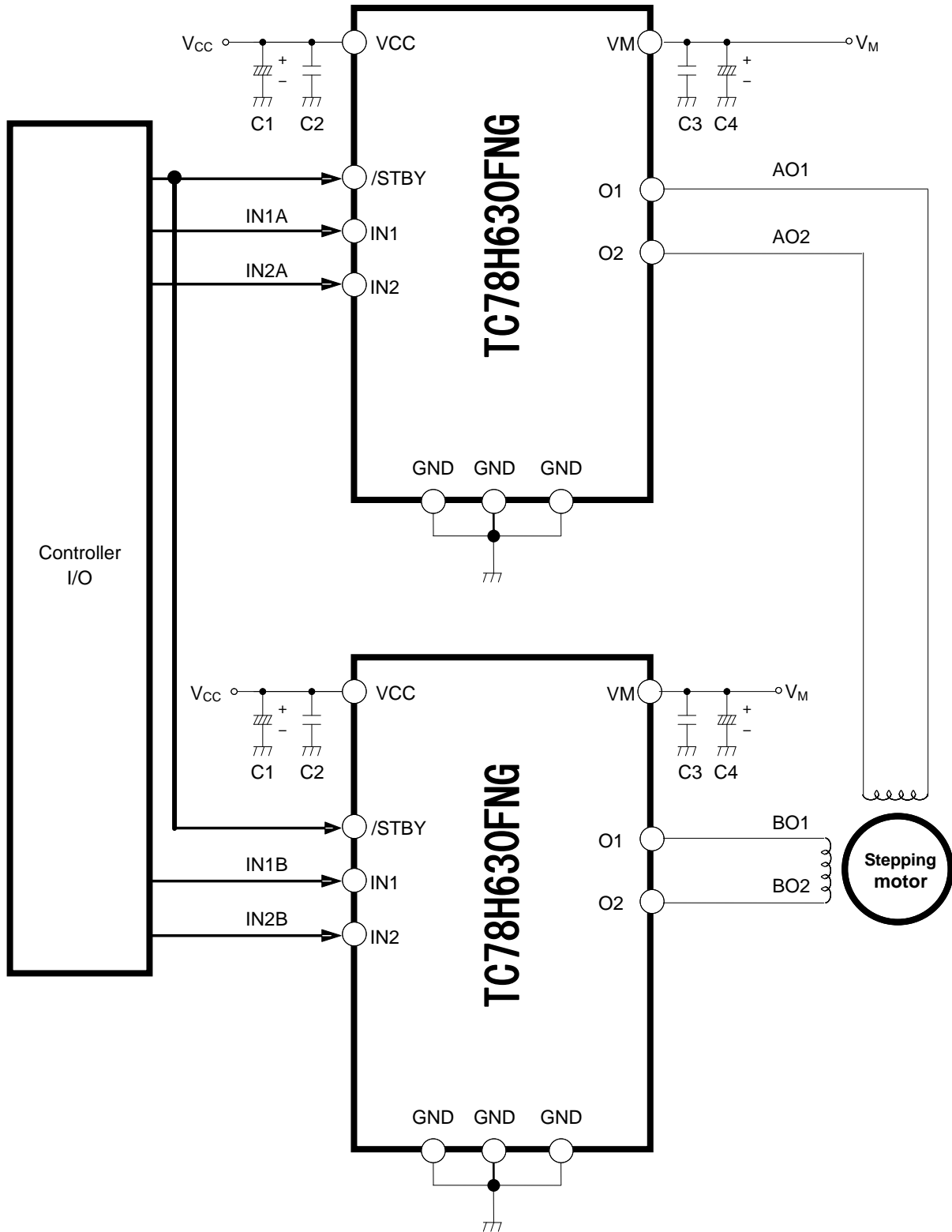

All the grounding wires of the device must run on the solder mask on the PCB and be externally terminated at only one point.

The application circuits shown in this document are provided for reference purposes only. Thorough evaluation is required, especially at the mass production design stage.

(1) Capacitor for the V_{CC} power supply

A power supply capacitor should be connected between V_{CC} and GND as close as possible to the IC.

Recommended capacitor values

Item	Recommended range	Remarks
C1	10 μF to 100 μF	Electrolytic capacitor
C2	0.1 μF to 1 μF	Ceramic capacitor

(2) Capacitor for the V_M power supply

A power supply capacitor should be connected between V_M and GND as close as possible to the IC.

Recommended capacitor values

Item	Recommended range	Remarks
C3	10 μF to 100 μF	Electrolytic capacitor
C4	0.1 μF to 1 μF	Ceramic capacitor

6. I/O function

/STBY	Input		Output		
	IN1	IN2	O1	O2	Mode
H	H	H	L	L	Short brake
H	L	H	L	H	Forward/Reverse
H	H	L	H	L	Reverse/Forward
H	L	L	OFF (High impedance)		Stop
L	—	—	OFF (High impedance)		Stand by

7. Protection function

• **Thermal shutdown circuit (TSD)**

Thermal shutdown circuit (TSD) operates when the junction temperature rises to 170°C (typ.) or more. All output power transistors are turned off. During TSD operation, the IC operation is in stop mode, which is the same as the configuration of 'IN1/IN2=L'. The normal operation resumes when the temperature falls to 130°C (typ.) or less.

*Operation temperature and release temperature of TSD written above are a reference value, and are not guaranteed.

• **Over-current detection circuit (ISD)**

Over-current detection circuit operates when the current exceeding 3.4 A (typ.) flows in the output transistor. All output power transistors are turned off. The dead band time of 4 μs (typ.) is provided in the IC to avoid malfunction by switching etc. During ISD operation, the IC operation is in stop mode, which is the same as the configuration of 'IN1/IN2=L'. The output transistors are turned on when one of the following controls is performed.

1. Re-investment of a power supply
2. After setting to standby mode (/STBY = L), it sets to operational mode again.

*The actuating current and masking term of the ISD are a reference value, and are not a guaranteed value.

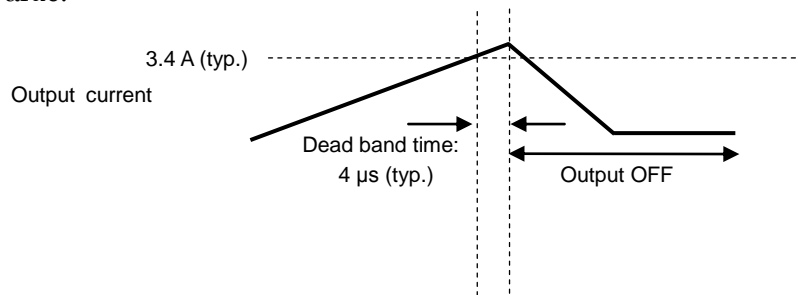

• **Under voltage lockout circuit (UVLO)**

Under voltage detection circuit operates when VCC voltage falls to 2.2 V (typ.) or less. All output power transistors are turned off. During UVLO operation, the IC operation is in stop mode, which is the same as the configuration of 'IN1/IN2=L'. The normal operation resumes when VCC voltage rises to 2.3 V (typ.) or more.

Also, UVLO operates when VM voltage falls to 2.0 V (typ.) or less. All output power transistors are turned off. During UVLO operation, the IC operation is in stop mode, which is the same as the configuration of 'IN1/IN2=L'. The normal operation resumes when VM voltage rises to 2.1 V (typ.) or more.

*Operation voltage and release voltage of UVLO written above are a reference value, and are not guaranteed.

8. Drive of bipolar type stepping motor with two TC78H630FNG.

Bipolar stepping motor drives with the input signal waveform shown below.

I_{out}: Current direction of 'AO1 to AO2 (or BO1 to BO2)' is defined 'plus current'. Current direction of AO2 to AO1 (or BO2 to BO1) is defined 'minus current'.

(1) Excitation mode: Full step resolution

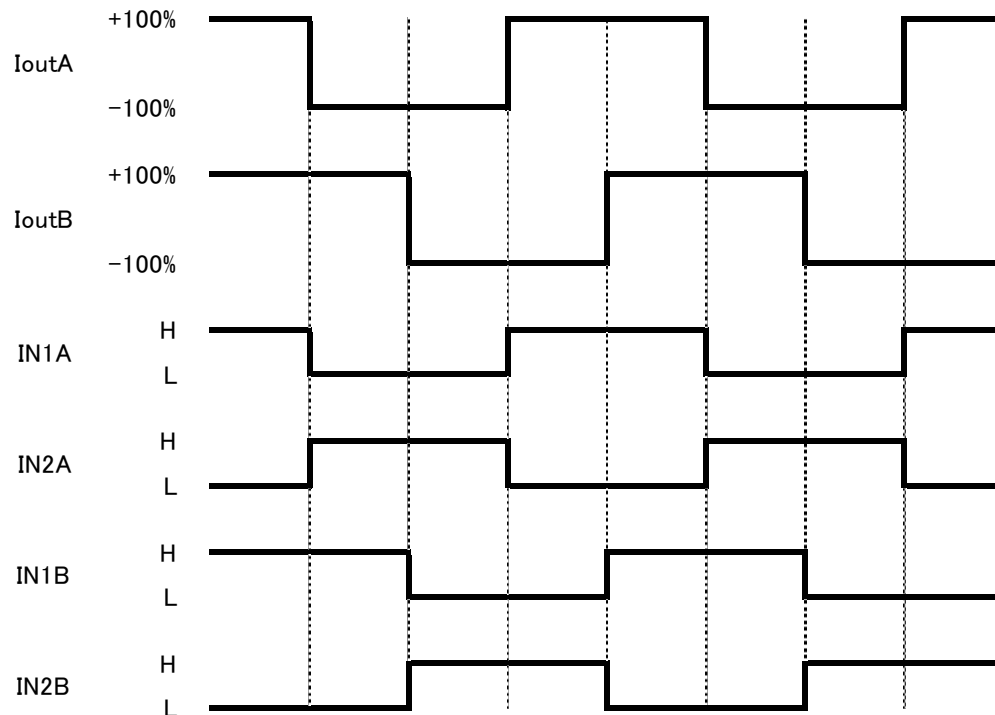

(2) Excitation mode: Half step resolution

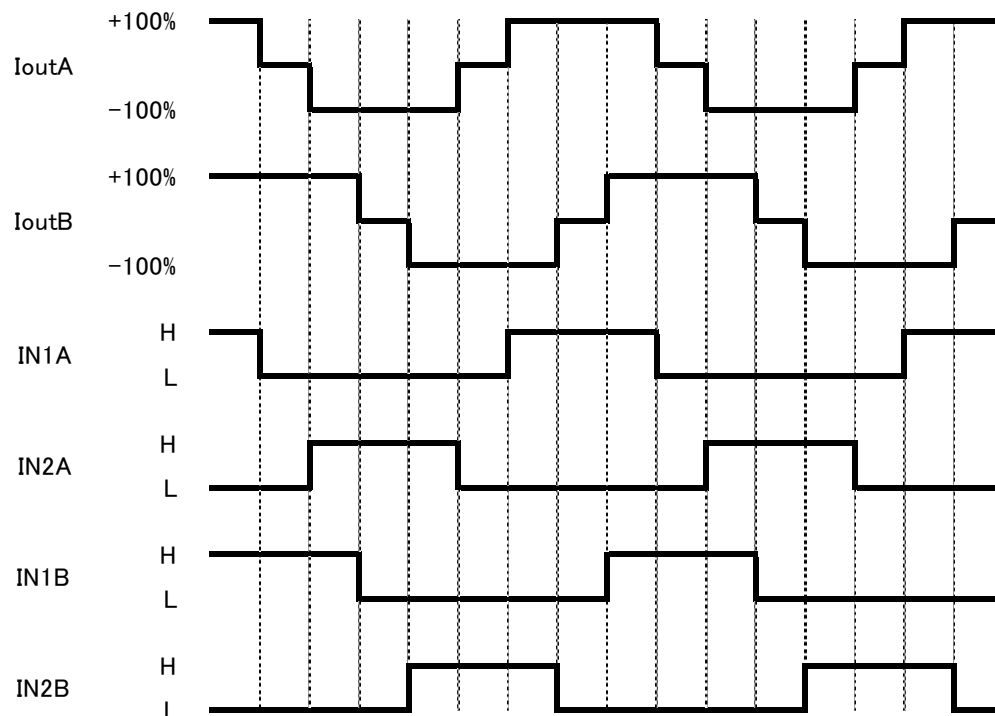

9. Reference foot pattern example

Unit: mm

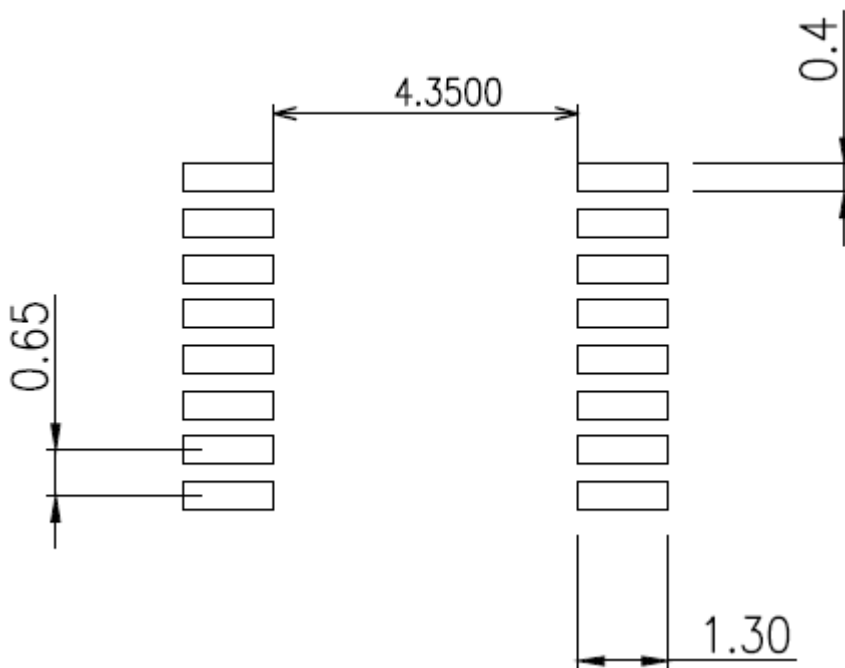

Toshiba does not guarantee the data for mass production. Please use the data as reference data for customer's application.

In determining the size of mounting board, design the most appropriate pattern by considering the solder bridge, the solder connecting strength, the pattern accuracy in making board, the heat sink of leads, and the mounting accuracy of the IC board.

Notes on Contents

1. Block Diagrams

Some of the functional blocks, circuits, or constants in the block diagram may be omitted or simplified for explanatory purposes.

2. Equivalent Circuits

The equivalent circuit diagrams may be simplified or some parts of them may be omitted for explanatory purposes.

3. Timing Charts

Timing charts may be simplified for explanatory purposes.

4. Application Circuits

The application circuits shown in this document are provided for reference purposes only. Thorough evaluation is required, especially at the mass production design stage.

Toshiba does not grant any license to any industrial property rights by providing these examples of application circuits.

5. Test Circuits

Components in the test circuits are used only to obtain and confirm the device characteristics.

These components and circuits are not guaranteed to prevent malfunction or failure from occurring in the application equipment.

IC Usage Considerations

Notes on handling of ICs

- (1) The absolute maximum ratings of a semiconductor device are a set of ratings that must not be exceeded, even for a moment. Do not exceed any of these ratings. Exceeding the rating(s) may cause the device breakdown, damage or deterioration, and may result injury by explosion or combustion.
- (2) Use an appropriate power supply fuse to ensure that a large current does not continuously flow in case of over current and/or IC failure. The IC will fully break down when used under conditions that exceed its absolute maximum ratings, when the wiring is routed improperly or when an abnormal pulse noise occurs from the wiring or load, causing a large current to continuously flow and the breakdown can lead smoke or ignition. To minimize the effects of the flow of a large current in case of breakdown, appropriate settings, such as fuse capacity, fusing time and insertion circuit location, are required.
- (3) If your design includes an inductive load such as a motor coil, incorporate a protection circuit into the design to prevent device malfunction or breakdown caused by the current resulting from the inrush current at power ON or the negative current resulting from the back electromotive force at power OFF. IC breakdown may cause injury, smoke or ignition. Use a stable power supply with ICs with built-in protection functions. If the power supply is unstable, the protection function may not operate, causing IC breakdown. IC breakdown may cause injury, smoke or ignition.
- (4) Do not insert devices in the wrong orientation or incorrectly. Make sure that the positive and negative terminals of power supplies are connected properly. Otherwise, the current or power consumption may exceed the absolute maximum rating, and exceeding the rating(s) may cause the device breakdown, damage or deterioration, and may result injury by explosion or combustion. In addition, do not use any device that is applied the current with inserting in the wrong orientation or incorrectly even just one time.
- (5) Carefully select external components (such as inputs and negative feedback capacitors) and load components (such as speakers), for example, power amp and regulator. If there is a large amount of leakage current such as input or negative feedback condenser, the IC output DC voltage will increase. If this output voltage is connected to a speaker with low input withstand voltage, overcurrent or IC failure can cause smoke or ignition. (The over current can cause smoke or ignition from the IC itself.) In particular, please pay attention when using a Bridge Tied Load (BTL) connection type IC that inputs output DC voltage to a speaker directly.

Points to remember on handling of ICs**(1) Over current Protection Circuit**

Over current protection circuits (referred to as current limiter circuits) do not necessarily protect ICs under all circumstances. If the over current protection circuits operate against the over current, clear the over current status immediately.

Depending on the method of use and usage conditions, such as exceeding absolute maximum ratings can cause the over current protection circuit to not operate properly or IC breakdown before operation. In addition, depending on the method of use and usage conditions, if over current continues to flow for a long time after operation, the IC may generate heat resulting in breakdown.

(2) Thermal Shutdown Circuit

Thermal shutdown circuits do not necessarily protect ICs under all circumstances. If the thermal shutdown circuits operate against the over temperature, clear the heat generation status immediately.

Depending on the method of use and usage conditions, such as exceeding absolute maximum ratings can cause the thermal shutdown circuit to not operate properly or IC breakdown before operation.

(3) Heat Radiation Design

In using an IC with large current flow such as power amp, regulator or driver, please design the device so that heat is appropriately radiated, not to exceed the specified junction temperature (T_j) at any time and condition. These ICs generate heat even during normal use. An inadequate IC heat radiation design can lead to decrease in IC life, deterioration of IC characteristics or IC breakdown. In addition, please design the device taking into consideration the effect of IC heat radiation with peripheral components.

(4) Back-EMF

When a motor rotates in the reverse direction, stops or slows down abruptly, a current flow back to the motor's power supply due to the effect of back-EMF. If the current sink capability of the power supply is small, the device's motor power supply and output pins might be exposed to conditions beyond absolute maximum ratings. To avoid this problem, take the effect of back-EMF into consideration in system design.

RESTRICTIONS ON PRODUCT USE

- Toshiba Corporation, and its subsidiaries and affiliates (collectively "TOSHIBA"), reserve the right to make changes to the information in this document, and related hardware, software and systems (collectively "Product") without notice.
- This document and any information herein may not be reproduced without prior written permission from TOSHIBA. Even with TOSHIBA's written permission, reproduction is permissible only if reproduction is without alteration/omission.
- Though TOSHIBA works continually to improve Product's quality and reliability, Product can malfunction or fail. Customers are responsible for complying with safety standards and for providing adequate designs and safeguards for their hardware, software and systems which minimize risk and avoid situations in which a malfunction or failure of Product could cause loss of human life, bodily injury or damage to property, including data loss or corruption. Before customers use the Product, create designs including the Product, or incorporate the Product into their own applications, customers must also refer to and comply with (a) the latest versions of all relevant TOSHIBA information, including without limitation, this document, the specifications, the data sheets and application notes for Product and the precautions and conditions set forth in the "TOSHIBA Semiconductor Reliability Handbook" and (b) the instructions for the application with which the Product will be used with or for. Customers are solely responsible for all aspects of their own product design or applications, including but not limited to (a) determining the appropriateness of the use of this Product in such design or applications; (b) evaluating and determining the applicability of any information contained in this document, or in charts, diagrams, programs, algorithms, sample application circuits, or any other referenced documents; and (c) validating all operating parameters for such designs and applications. **TOSHIBA ASSUMES NO LIABILITY FOR CUSTOMERS' PRODUCT DESIGN OR APPLICATIONS.**
- **PRODUCT IS NEITHER INTENDED NOR WARRANTED FOR USE IN EQUIPMENTS OR SYSTEMS THAT REQUIRE EXTRAORDINARILY HIGH LEVELS OF QUALITY AND/OR RELIABILITY, AND/OR A MALFUNCTION OR FAILURE OF WHICH MAY CAUSE LOSS OF HUMAN LIFE, BODILY INJURY, SERIOUS PROPERTY DAMAGE AND/OR SERIOUS PUBLIC IMPACT ("UNINTENDED USE").** Except for specific applications as expressly stated in this document, Unintended Use includes, without limitation, equipment used in nuclear facilities, equipment used in the aerospace industry, medical equipment, equipment used for automobiles, trains, ships and other transportation, traffic signaling equipment, equipment used to control combustions or explosions, safety devices, elevators and escalators, devices related to electric power, and equipment used in finance-related fields. **IF YOU USE PRODUCT FOR UNINTENDED USE, TOSHIBA ASSUMES NO LIABILITY FOR PRODUCT.** For details, please contact your TOSHIBA sales representative.
- Do not disassemble, analyze, reverse-engineer, alter, modify, translate or copy Product, whether in whole or in part.
- Product shall not be used for or incorporated into any products or systems whose manufacture, use, or sale is prohibited under any applicable laws or regulations.
- The information contained herein is presented only as guidance for Product use. No responsibility is assumed by TOSHIBA for any infringement of patents or any other intellectual property rights of third parties that may result from the use of Product. No license to any intellectual property right is granted by this document, whether express or implied, by estoppel or otherwise.
- **ABSENT A WRITTEN SIGNED AGREEMENT, EXCEPT AS PROVIDED IN THE RELEVANT TERMS AND CONDITIONS OF SALE FOR PRODUCT, AND TO THE MAXIMUM EXTENT ALLOWABLE BY LAW, TOSHIBA (1) ASSUMES NO LIABILITY WHATSOEVER, INCLUDING WITHOUT LIMITATION, INDIRECT, CONSEQUENTIAL, SPECIAL, OR INCIDENTAL DAMAGES OR LOSS, INCLUDING WITHOUT LIMITATION, LOSS OF PROFITS, LOSS OF OPPORTUNITIES, BUSINESS INTERRUPTION AND LOSS OF DATA, AND (2) DISCLAIMS ANY AND ALL EXPRESS OR IMPLIED WARRANTIES AND CONDITIONS RELATED TO SALE, USE OF PRODUCT, OR INFORMATION, INCLUDING WARRANTIES OR CONDITIONS OF MERCHANTABILITY, FITNESS FOR A PARTICULAR PURPOSE, ACCURACY OF INFORMATION, OR NONINFRINGEMENT.**
- Do not use or otherwise make available Product or related software or technology for any military purposes, including without limitation, for the design, development, use, stockpiling or manufacturing of nuclear, chemical, or biological weapons or missile technology products (mass destruction weapons). Product and related software and technology may be controlled under the applicable export laws and regulations including, without limitation, the Japanese Foreign Exchange and Foreign Trade Law and the U.S. Export Administration Regulations. Export and re-export of Product or related software or technology are strictly prohibited except in compliance with all applicable export laws and regulations.
- Please contact your TOSHIBA sales representative for details as to environmental matters such as the RoHS compatibility of Product. Please use Product in compliance with all applicable laws and regulations that regulate the inclusion or use of controlled substances, including without limitation, the EU RoHS Directive. **TOSHIBA ASSUMES NO LIABILITY FOR DAMAGES OR LOSSES OCCURRING AS A RESULT OF NONCOMPLIANCE WITH APPLICABLE LAWS AND REGULATIONS.**