

TOSHIBA CMOS Digital Integrated Circuit Silicon Monolithic

TC90193ASBG

Video signal processing IC for small LCD

1. Overview

TC90193ASBG is a video processing IC for small LCD panel (QVGA to WVGA).

It corresponds to the input of an analog CVBS signal and digital RGB signal.

It performs video(picture) processing to the selected input signal, and outputs the digital RGB picture signal and panel control signal of QVGA-WVGA.

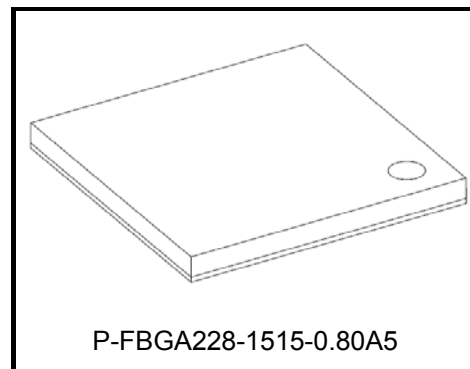

P-FBGA228-1515-0.80A5

Weight : 0.50g(Typ.)

1.1 Features

1. Video signal input
 - Analog CVBS(NTSC/PAL)
 - Digital RGB signal (6bit × 3 or 8bit × 3)
2. 8bit ADC, Pre-filter(LPF) for input analog video signal
3. 3Line YC separation
4. Multi-color system Decoder
5. Digital RGB signal output (24bit)
 - QVGA(320x240)
 - WQVGA(400x234, 400x240, 480x234, 480x240, 480x272)
 - VGA(640x480)
 - WVGA(800x480)
6. Timing control pulse output for LCD panel
7. Scaling function
 - Horizontal aberration correction
 - Horizontal compressed function
 - Horizontal/Vertical over-scan
8. Picture Quality Improvement function
 - <Y signal process>
 - HVD Enhancer
 - Sharpness, LTI, Noise reducer
 - Static Y-gamma correction
 - Dynamic Y-gamma correction
 - Contrast, Brightness
 - <C signal process>
 - CTI, Noise reducer
 - C gain correction with Y-gamma correction
 - Color management
 - Color gain, Cb/Cr offset adjustment
 - <RGB signal process>
 - Offset adjustment, Gain adjustment
 - RGB-gamma correction
 - Dither, FRC (Frame Rate Control)
9. PWM signal output
10. External digital RGB signal is superimposed.
11. I²C-BUS control
12. Package: P-FBGA228-1515-0.80A5
13. Power Supply: 3.3V, 2.5V, 1.5V
14. Operating temperature: -40°C to 85°C

2. Block Diagram

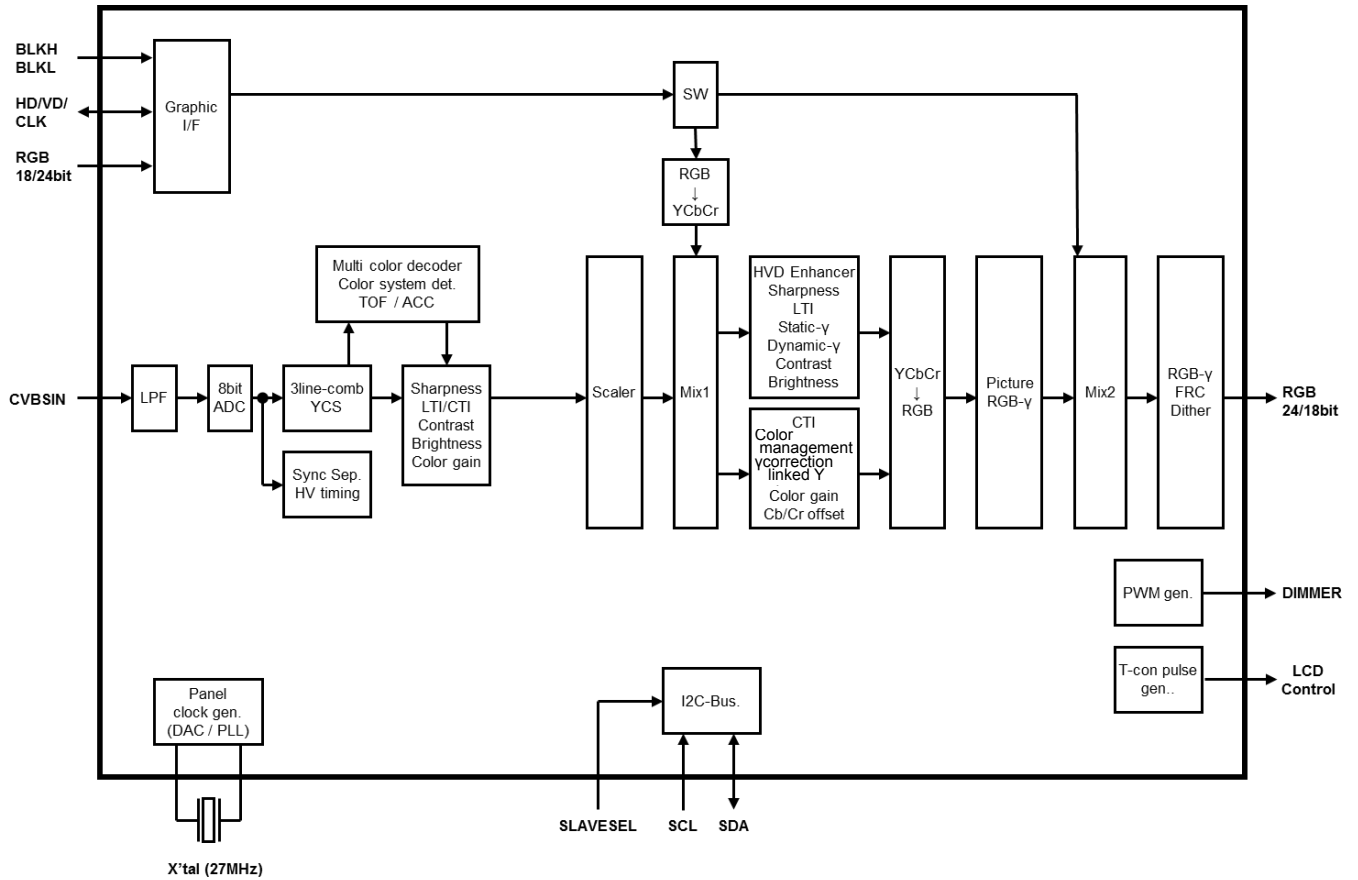

3. Pin Layout

Package TOP VIEW

	1	2	3	4	5	6	7	8	9	10	11	12	13	14	15	16	17	
A	BLKL	BLKH	DINCLK	PTH	BOUT0	VDDIO	BOUT3	BOUT5	DVDD	DVDD	GOUT0	GOUT2	VDDIO	VDDIO	GOUT6	ROUT0	ROUT2	A
B	DIN1	DIN0	DINHDL	DINVD	OSDCLK	BOUT1	BOUT2	BOUT4	BOUT6	BOUT7	GOUT1	GOUT3	GOUT4	GOUT5	GOUT7	ROUT1	ROUT3	B
C	DIN3	DIN2	DVSS	DVSS	DVSS	DVSS	DVSS	DVSS	DVSS	DVSS	DVSS	DVSS	DVSS	DVSS	DVSS	ROUT4	ROUT5	C
D	DIN5	DIN4	DVSS	-	DVSS	DVSS	DVSS	DVSS	DVSS	DVSS	DVSS	DVSS	DVSS	-	DVSS	ROUT6	VDDIO	D
E	VDDIO	DIN6	DVSS	DVSS	-	-	-	-	-	-	-	-	-	DVSS	DVSS	ROUT7	LOAD	E
F	DIN8	DIN7	DVSS	DVSS	-	DVSS	DVSS	DVSS	DVSS	DVSS	DVSS	-	-	DVSS	DVSS	DIMMER	ENABLE	F
G	DIN10	DIN9	DVSS	DVSS	-	DVSS	DVSS	-	-	-	-	DVSS	-	DVSS	DVSS	STH	HCOM	G
H	DVDD	DIN11	DVSS	DVSS	-	DVSS	-	-	-	-	-	DVSS	-	DVSS	DVSS	GOE	DVDD	H
J	DVDD	DIN12	DVSS	DVSS	-	DVSS	-	-	-	-	-	DVSS	-	DVSS	DVSS	DVSS	DVDD	J
K	DIN13	DIN14	DVSS	DVSS	-	DVSS	-	-	-	-	-	DVSS	-	DVSS	DVSS	CPH	STV1	K
L	DIN15	DIN16	DVSS	DVSS	-	DVSS	-	-	-	-	-	DVSS	-	DVSS	DVSS	CPV	VLOAD	L
M	DIN17	DIN18	DVSS	DVSS	-	DVSS	DVSS	DVSS	DVSS	DVSS	DVSS	DVSS	-	DVSS	DVSS	VCOM2	VCOM1	M
N	VDDIO	DIN19	DVSS	DVSS	-	-	-	-	-	-	-	-	-	AVSS	DVSS	DVSS	VDDIO	N
P	DIN20	DIN21	DVSS	-	DVSS	DVSS	DVSS	DVSS	DVSS	DVSS	XVSS	DAVSS	DAVSS	-	AVSS	AVSS	AVSS	P
R	DIN22	DIN23	DVSS	DVSS	DVSS	DVSS	DVSS	DVSS	DVSS	DVSS	XVSS	DAVSS	DAVSS	DAVSS	AVSS	BIAS	CVBSIN	R
T	DIN24	DIN25	SDA	DVSS	DVSS	SLVSEL	SGSEL	TEST3	TEST2	TEST1	XI	PLL1IN	DAVSS	PLL1FL	DACOUT	AVSS	VRB	T
U	TEST	PANEL SELECTION	SCL	VDDIO	DVSS	RESET	MUTEIN	DVDD	DVDD	TEST0	XO	XVDD	DAVSS	DAVDD	AVDD	VRT	AVSS	U
	1	2	3	4	5	6	7	8	9	10	11	12	13	14	15	16	17	

4. Pin Description

Pin No.	Pin Name	Block	IO	Function	Standard withstand voltage[V]
A1	BLKL	Digital	I	OSD Blanking control input (For halftone)	3.3
B1	DIN1	Digital	I	R1<8bit> input / R1<6bit> input	3.3
C1	DIN3	Digital	I	R3<8bit> input / R3<6bit> input	3.3
D1	DIN5	Digital	I	R5<8bit> input / R5<6bit> input	3.3
E1	VDDIO	Power	-	3.3V power supply for I/O block	-
F1	DIN8	Digital	I	G0<8bit> input / G2<6bit> input	3.3
G1	DIN10	Digital	I	G2<8bit> input / G4<6bit> input	3.3
H1	DVDD	Power	-	1.5V power supply for internal logic	-
J1	DVDD	Power	-	1.5V power supply for internal logic	-
K1	DIN13	Digital	I	G5<8bit> input / B1<6bit> input	3.3
L1	DIN15	Digital	I	G7<8bit> input / B3<6bit> input	3.3
M1	DIN17	Digital	I	B1<8bit> input / B5<6bit> input	3.3
N1	VDDIO	Power	-	3.3V power supply for I/O block	-
P1	DIN20	Digital	I	B4<8bit> input	3.3
R1	DIN22	Digital	I	B6<8bit> input	3.3
T1	DIN24	Digital	I	TEST pin (connect GND)	3.3
U1	TEST	Digital	I	TEST pin (connect GND)	3.3
A2	BLKH	Digital	I	OSD Blanking control input	3.3
B2	DIN0	Digital	I	R0<8bit> input / R0<6bit> input	3.3
C2	DIN2	Digital	I	R2<8bit> input / R2<6bit> input	3.3
D2	DIN4	Digital	I	R4<8bit> input / R4<6bit> input	3.3
E2	DIN6	Digital	I	R6<8bit> input / G0<6bit> input	3.3
F2	DIN7	Digital	I	R7<8bit> input / G1<6bit> input	3.3
G2	DIN9	Digital	I	G1<8bit> input / G3<6bit> input	3.3
H2	DIN11	Digital	I	G3<8bit> input / G5<6bit> input	3.3
J2	DIN12	Digital	I	G4<8bit> input / B0<6bit> input	3.3
K2	DIN14	Digital	I	G6<8bit> input / B2<6bit> input	3.3
L2	DIN16	Digital	I	B0<8bit> input / B4<6bit> input	3.3
M2	DIN18	Digital	I	B2<8bit> input	3.3
N2	DIN19	Digital	I	B3<8bit> input	3.3
P2	DIN21	Digital	I	B5<8bit> input	3.3
R2	DIN23	Digital	I	B7<8bit> input	3.3
T2	DIN25	Digital	I	TEST pin (connect GND)	3.3
U2	PANELSELECT	Digital	I	Setup polarity of GOE signal output	3.3
A3	DINCLK	Digital	I	RGB Clock signal input	3.3
B3	DINHDD	Digital	I/O	RGB HD input(Default) / OSD HD output	3.3
C3	DVSS	Power	-	Digital GND	-
D3	DVSS	Power	-	Digital GND	-
E3	DVSS	Power	-	Digital GND	-
F3	DVSS	Power	-	Digital GND	-
G3	DVSS	Power	-	Digital GND	-
H3	DVSS	Power	-	Digital GND	-
J3	DVSS	Power	-	Digital GND	-
K3	DVSS	Power	-	Digital GND	-
L3	DVSS	Power	-	Digital GND	-
M3	DVSS	Power	-	Digital GND	-
N3	DVSS	Power	-	Digital GND	-
P3	DVSS	Power	-	Digital GND	-
R3	DVSS	Power	-	Digital GND	-
T3	SDA	Digital	I/O	I ² C-BUS SDA	5
U3	SCL	Digital	I	I ² C-BUS SCL	5

Pin No.	Pin Name	Block	IO	Function	Standard withstand voltage[V]
A4	PTH	Digital	I	Mask control for picture quality of Digital input	3.3
B4	DINVD	Digital	I/O	RGB VD input(Default) / OSD VD output	3.3
C4	DVSS	Power	-	Digital GND	-
D4	-	-	-	Not connect (No ball)	-
E4	DVSS	Power	-	Digital GND	-
F4	DVSS	Power	-	Digital GND	-
G4	DVSS	Power	-	Digital GND	-
H4	DVSS	Power	-	Digital GND	-
J4	DVSS	Power	-	Digital GND	-
K4	DVSS	Power	-	Digital GND	-
L4	DVSS	Power	-	Digital GND	-
M4	DVSS	Power	-	Digital GND	-
N4	DVSS	Power	-	Digital GND	-
P4	-	-	-	Not connect (No ball)	-
R4	DVSS	Power	-	Digital GND	-
T4	DVSS	Power	-	Digital GND	-
U4	VDDIO	Power	-	3.3V power supply for I/O block	-
A5	BOU0	Digital	O	Digital RGB output(B0)	3.3
B5	OSDCLK	Digital	O	OSD clock output	3.3
C5	DVSS	Power	-	Digital GND	-
D5	DVSS	Power	-	Digital GND	-
E5	-	-	-	Not connect (No ball)	-
F5	-	-	-	Not connect (No ball)	-
G5	-	-	-	Not connect (No ball)	-
H5	-	-	-	Not connect (No ball)	-
J5	-	-	-	Not connect (No ball)	-
K5	-	-	-	Not connect (No ball)	-
L5	-	-	-	Not connect (No ball)	-
M5	-	-	-	Not connect (No ball)	-
N5	-	-	-	Not connect (No ball)	-
P5	DVSS	Power	-	Digital GND	-
R5	DVSS	Power	-	Digital GND	-
T5	DVSS	Power	-	Digital GND	-
U5	DVSS	Power	-	Digital GND	-
A6	VDDIO	Power	-	3.3V power supply for I/O block	-
B6	BOU1	Digital	O	Digital RGB output(B1)	3.3
C6	DVSS	Power	-	Digital GND	-
D6	DVSS	Power	-	Digital GND	-
E6	-	-	-	Not connect (No ball)	-
F6	DVSS	Power	-	Digital GND	-
G6	DVSS	Power	-	Digital GND	-
H6	DVSS	Power	-	Digital GND	-
J6	DVSS	Power	-	Digital GND	-
K6	DVSS	Power	-	Digital GND	-
L6	DVSS	Power	-	Digital GND	-
M6	DVSS	Power	-	Digital GND	-
N6	-	-	-	Not connect (No ball)	-
P6	DVSS	Power	-	Digital GND	-
R6	DVSS	Power	-	Digital GND	-
T6	SLVSEL	Digital	I	I ² C-BUS Slave address select	3.3
U6	RESET	Digital	I	Reset	5

Pin No.	Pin Name	Block	IO	Function	Standard withstand voltage[V]
A7	BOUT3	Digital	O	Digital RGB output(B3)	3.3
B7	BOUT2	Digital	O	Digital RGB output(B2)	3.3
C7	DVSS	Power	-	Digital GND	-
D7	DVSS	Power	-	Digital GND	-
E7	-	-	-	Not connect (No ball)	-
F7	DVSS	Power	-	Digital GND	-
G7	DVSS	Power	-	Digital GND	-
H7	-	-	-	Not connect (No ball)	-
J7	-	-	-	Not connect (No ball)	-
K7	-	-	-	Not connect (No ball)	-
L7	-	-	-	Not connect (No ball)	-
M7	DVSS	Power	-	Digital GND	-
N7	-	-	-	Not connect (No ball)	-
P7	DVSS	Power	-	Digital GND	-
R7	DVSS	Power	-	Digital GND	-
T7	SGSEL	Digital	I	CVBS input / Digital input select (H:Digital / L:Forced CVBS)	3.3
U7	MUTEIN	Digital	I	External forced mute	3.3
A8	BOUT5	Digital	O	Digital RGB output(B5)	3.3
B8	BOUT4	Digital	O	Digital RGB output(B4)	3.3
C8	DVSS	Power	-	Digital GND	-
D8	DVSS	Power	-	Digital GND	-
E8	-	-	-	Not connect (No ball)	-
F8	DVSS	Power	-	Digital GND	-
G8	-	-	-	Not connect (No ball)	-
H8	-	-	-	Not connect (No ball)	-
J8	-	-	-	Not connect (No ball)	-
K8	-	-	-	Not connect (No ball)	-
L8	-	-	-	Not connect (No ball)	-
M8	DVSS	Power	-	Digital GND	-
N8	-	-	-	Not connect (No ball)	-
P8	DVSS	Power	-	Digital GND	-
R8	DVSS	Power	-	Digital GND	-
T8	TEST3	Digital	I	TEST pin (connect GND)	3.3
U8	DVDD	Power	-	1.5V power supply for internal logic	-
A9	DVDD	Power	-	1.5V power supply for internal logic	-
B9	BOUT6	Digital	O	Digital RGB output(B6)	3.3
C9	DVSS	Power	-	Digital GND	-
D9	DVSS	Power	-	Digital GND	-
E9	-	-	-	Not connect (No ball)	-
F9	DVSS	Power	-	Digital GND	-
G9	-	-	-	Not connect (No ball)	-
H9	-	-	-	Not connect (No ball)	-
J9	-	-	-	Not connect (No ball)	-
K9	-	-	-	Not connect (No ball)	-
L9	-	-	-	Not connect (No ball)	-
M9	DVSS	Power	-	Digital GND	-
N9	-	-	-	Not connect (No ball)	-
P9	DVSS	Power	-	Digital GND	-
R9	DVSS	Power	-	Digital GND	-
T9	TEST2	Digital	I	TEST pin (connect GND)	3.3
U9	DVDD	Power	-	1.5V power supply for internal logic	-

Pin No.	Pin Name	Block	IO	Function	Standand withstand voltage[V]
A10	DVDD	Power	-	1.5V power supply for internal logic	-
B10	BOUT7	Digital	O	Digital RGB output(B7)	3.3
C10	DVSS	Power	-	Digital GND	-
D10	DVSS	Power	-	Digital GND	-
E10	-	-	-	Not connect (No ball)	-
F10	DVSS	Power	-	Digital GND	-
G10	-	-	-	Not connect (No ball)	-
H10	-	-	-	Not connect (No ball)	-
J10	-	-	-	Not connect (No ball)	-
K10	-	-	-	Not connect (No ball)	-
L10	-	-	-	Not connect (No ball)	-
M10	DVSS	Power	-	Digital GND	-
N10	-	-	-	Not connect (No ball)	-
P10	DVSS	Power	-	Digital GND	-
R10	DVSS	Power	-	Digital GND	-
T10	TEST1	Digital	I	TEST pin (connect GND)	3.3
U10	TEST0	Digital	I	TEST pin (connect GND)	3.3
A11	GOUT0	Digital	O	Digital RGB output(G0)	3.3
B11	GOUT1	Digital	O	Digital RGB output(G1)	3.3
C11	DVSS	Power	-	Digital GND	-
D11	DVSS	Power	-	Digital GND	-
E11	-	-	-	Not connect (No ball)	-
F11	DVSS	Power	-	Digital GND	-
G11	-	-	-	Not connect (No ball)	-
H11	-	-	-	Not connect (No ball)	-
J11	-	-	-	Not connect (No ball)	-
K11	-	-	-	Not connect (No ball)	-
L11	-	-	-	Not connect (No ball)	-
M11	DVSS	Power	-	Digital GND	-
N11	-	-	-	Not connect (No ball)	-
P11	XVSS	Power	-	X'tal GND	-
R11	XVSS	Power	-	X'tal GND	-
T11	XI	XTAL	I	Input pin of X'tal circuit	-
U11	XO	XTAL	O	Output pin of X'tal circuit	-
A12	GOUT2	Digital	O	Digital RGB output(G2)	3.3
B12	GOUT3	Digital	O	Digital RGB output(G3)	3.3
C12	DVSS	Power	-	Digital GND	-
D12	DVSS	Power	-	Digital GND	-
E12	-	-	-	Not connect (No ball)	-
F12	-	-	-	Not connect (No ball)	-
G12	DVSS	Power	-	Digital GND	-
H12	DVSS	Power	-	Digital GND	-
J12	DVSS	Power	-	Digital GND	-
K12	DVSS	Power	-	Digital GND	-
L12	DVSS	Power	-	Digital GND	-
M12	DVSS	Power	-	Digital GND	-
N12	-	-	-	Not connect (No ball)	-
P12	DAVSS	Analog Power	-	DAC/PLL1 GND	-
R12	DAVSS	Analog Power	-	DAC/PLL1 GND	-
T12	PLL1IN	Analog IN	I	PLL1 input	-
U12	XVDD	Power	-	2.5V power supply for X'tal	-

Pin No.	Pin Name	Block	IO	Function	Standard withstand voltage[V]
A13	VDDIO	Power	-	3.3V power supply for I/O block	-
B13	GOUT4	Digital	O	Digital RGB output(G4)	3.3
C13	DVSS	Power	-	Digital GND	-
D13	DVSS	Power	-	Digital GND	-
E13	-	-	-	Not connect (No ball)	-
F13	-	-	-	Not connect (No ball)	-
G13	-	-	-	Not connect (No ball)	-
H13	-	-	-	Not connect (No ball)	-
J13	-	-	-	Not connect (No ball)	-
K13	-	-	-	Not connect (No ball)	-
L13	-	-	-	Not connect (No ball)	-
M13	-	-	-	Not connect (No ball)	-
N13	-	-	-	Not connect (No ball)	-
P13	DAVSS	Analog Power	-	DAC/PLL1 GND	-
R13	DAVSS	Analog Power	-	DAC/PLL1 GND	-
T13	DAVSS	Analog Power	-	DAC/PLL1 GND	-
U13	DAVSS	Analog Power	-	DAC/PLL1 GND	-
A14	VDDIO	Power	-	3.3V power supply for I/O block	-
B14	GOUT5	Digital	O	Digital RGB output(G5)	3.3
C14	DVSS	Power	-	Digital GND	-
D14	-	-	-	Not connect (No ball)	-
E14	DVSS	Power	-	Digital GND	-
F14	DVSS	Power	-	Digital GND	-
G14	DVSS	Power	-	Digital GND	-
H14	DVSS	Power	-	Digital GND	-
J14	DVSS	Power	-	Digital GND	-
K14	DVSS	Power	-	Digital GND	-
L14	DVSS	Power	-	Digital GND	-
M14	DVSS	Power	-	Digital GND	-
N14	AVSS	Analog Power	-	ADC GND	-
P14	-	-	-	Not connect (No ball)	-
R14	DAVSS	Analog Power	-	DAC/PLL1 GND	-
T14	PLL1FIL	Analog Bias	O	Filter pin for PLL1	-
U14	DAVDD	Analog Power	-	2.5V power supply for DAC/PLL1	-
A15	GOUT6	Digital	O	Digital RGB output(G6)	3.3
B15	GOUT7	Digital	O	Digital RGB output(G7)	3.3
C15	DVSS	Power	-	Digital GND	-
D15	DVSS	Power	-	Digital GND	-
E15	DVSS	Power	-	Digital GND	-
F15	DVSS	Power	-	Digital GND	-
G15	DVSS	Power	-	Digital GND	-
H15	DVSS	Power	-	Digital GND	-
J15	DVSS	Power	-	Digital GND	-
K15	DVSS	Power	-	Digital GND	-
L15	DVSS	Power	-	Digital GND	-
M15	DVSS	Power	-	Digital GND	-
N15	DVSS	Power	-	Digital GND	-
P15	AVSS	Analog Power	-	ADC GND	-
R15	AVSS	Analog Power	-	ADC GND	-
T15	DACOUT	Analog OUT	O	DAC output	-
U15	AVDD	Analog Power	-	2.5V power supply for ADC	-

Pin No.	Pin Name	Block	IO	Function	Standard withstand voltage[V]
A16	ROUT0	Digital	O	Digital RGB output (R0)	3.3
B16	ROUT1	Digital	O	Digital RGB output (R1)	3.3
C16	ROUT4	Digital	O	Digital RGB output (R4)	3.3
D16	ROUT6	Digital	O	Digital RGB output (R6)	3.3
E16	ROUT7	Digital	O	Digital RGB output (R7)	3.3
F16	DIMMER	Digital	O	PWM signal output	3.3
G16	STH	Digital	O	Control signal for LCD (Start signal of H)	3.3
H16	GOE	Digital	O	Reset signal for LCD panel	3.3
J16	DVSS	Power	-	Digital GND	-
K16	CPH	Digital	O	Control signal for LCD (Source clock signal of H)	3.3
L16	CPV	Digital	O	Control signal for LCD (Gate clock signal of V)	3.3
M16	VCOM2	Digital	O	Control signal for LCD (Common voltage output 2)	3.3
N16	DVSS	Power	-	Digital GND	-
P16	AVSS	Analog Power	-	ADC GND	-
R16	BIAS	Analog Bias	-	Bias pin of ADC	-
T16	AVSS	Analog Power	-	ADC GND	-
U16	VRT	Analog Bias	-	Reference top voltage pin of ADC	-
A17	ROUT2	Digital	O	Digital RGB output(R2)	3.3
B17	ROUT3	Digital	O	Digital RGB output(R3)	3.3
C17	ROUT5	Digital	O	Digital RGB output(R5)	3.3
D17	VDDIO	Power	-	3.3V power supply for I/O block	-
E17	LOAD	Digital	O	Control signal for LCD (Latch signal of H)	3.3
F17	ENABLE	Digital	O	Control signal for LCD (Data Enable)	3.3
G17	HCOM	Digital	O	Control signal for LCD (Invert signal for each dot.)	3.3
H17	DVDD	Power	-	1.5V power supply for internal logic	-
J17	DVDD	Power	-	1.5V power supply for internal logic	-
K17	STV1	Digital	O	Control signal for LCD (Start signal for V gate 1)	3.3
L17	VLOAD	Digital	O	Control signal for LCD (Latch signal of V direction)	3.3
M17	VCOM1	Digital	O	Control signal for LCD (Common voltage output 1)	3.3
N17	VDDIO	Power	-	3.3V power supply for I/O block	-
P17	AVSS	Analog Power	-	ADC GND	-
R17	CVBSIN	Analog IN	I	Analog CVBS signal input	-
T17	VRB	Analog Bias	-	Reference bottom voltage pin of ADC	-
U17	AVSS	Analog Power	-	ADC GND	-

Regarding processing of unused terminals,

Input terminal : It is recommended to connect it to GND to prevent the input terminal from becoming undefined state. Since there is no pull-down circuit, pull-down connection is recommended when you want to suppress minute leakage current.

Output terminal : Open is recommended to eliminate unnecessary current.

Input / Output terminal : Open status is recommended because it may be output status.

5. Function

5.1 Video signal input

TC90193ASBG will be able to input the analog CVBS signal of one route and one route of digital RGB signal.

When the analog CVBS signal input is selected, the digital RGB(Ex.OSD) signal can be superimposed on the analog CVBS signal by inputting synchronized digital RGB signal to synchronization signal from the TC90193ASBG.

When only a digital RGB signal is chosen as an input signal, HD, VD, and CLK which were Synchronized with digital RGB can be inputted, and digital RGB can be displayed.

The effective number of pixels can be selected from the table below by internal register settings.

<Effective pixels of digital RGB signal>

Resolution type	Horizontal effective pixels	Vertical effective pixels
QVGA	320	240
WQVGA	400	234
WQVGA	400	240
WQVGA	480	234
WQVGA	480	240
WQVGA	480	272
VGA	640	480
WVGA	800	480

5.1.1 Analog CVBS signal input

5.1.1.1. About input signal

TC90193ASBG has one channel 8bit ADC for analog CVBS signal input.
 Dynamic range of ADC is designed in $AVDD \times 0.4$. The normal input dynamic range is 1.0Vp-p ($AVDD = 2.5V$).
 Recommendation standard input amplitude is set to 0.7Vpp at the time of a 140IRE input.

The clamp process for CVBS signal is pedestal clamp of sync-feed-back type.
 And, TC90193ASBG has digital clamp process after ADC process.

5.1.1.2. Reference input level for analog CVBS signal

Reference input level for analog CVBS signal.

<IRE>

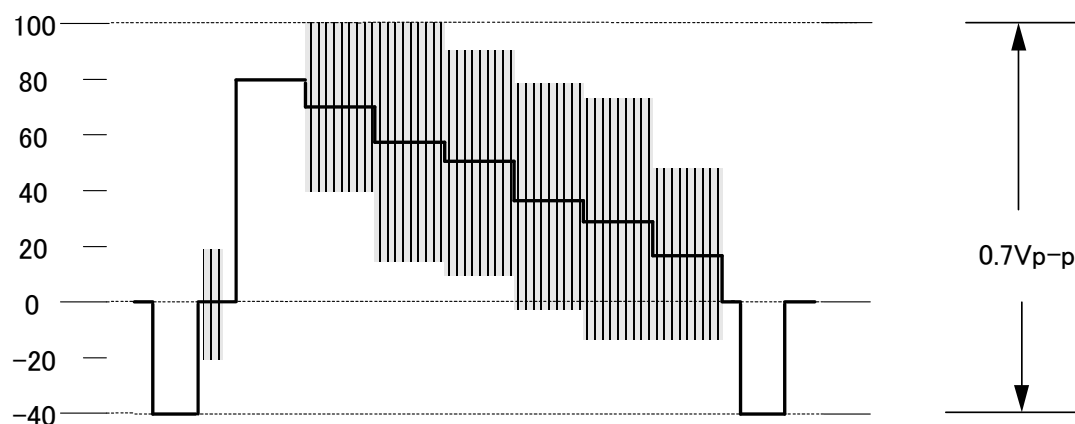

5.1.1.3. LPF function

LPF for anti-aliasing is built-in before ADC.
 It is the selectable of "LPF through" or "via the LPF".

5.1.2 Digital RGB signal input

5.1.2.1. Normal mode

In normal mode only displays digital RGB input.
 In normal mode, input of HD, VD and CLK is necessary.
 (Seg:0x00,Sub:0x00, D7:1) .
 Input horizontal and vertical back porch width (width from a front tip of H/V sync to an effective starting position) with a fixed value.
 The Width of HD pulse is necessary more than 300ns. If less than 300ns, input signal is judged as no-signal.

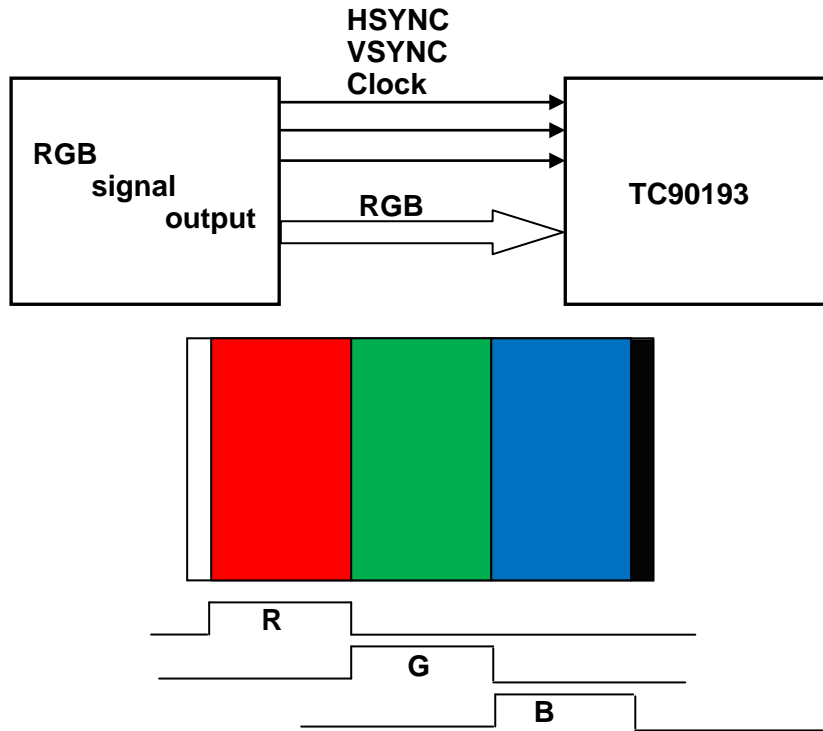

RGB inputs and picture image

5.1.2.2. Synchronized mode

In this mode, digital RGB signal can be overlaid on analog CVBS signal.
 (Digital RGB is used for overlay of OSD.)
 Set the SGSEL pin to High and set the Seg:0x00,Sub:0x00,D7:0 to becomes CVBS input.
 In this synchronous mode, the digital RGB signal synchronized with the signal(HD, VD, clock) output from TC90193 is input again to TC90193.The setting is Seg:0x00,Sub:0x50,D7:1. 0x56,D7:1

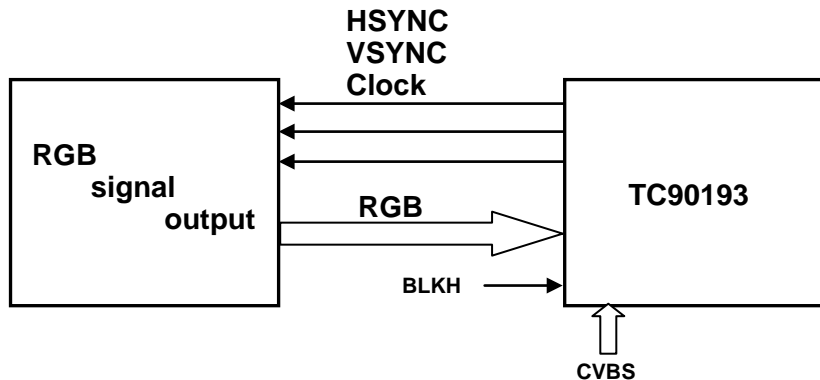

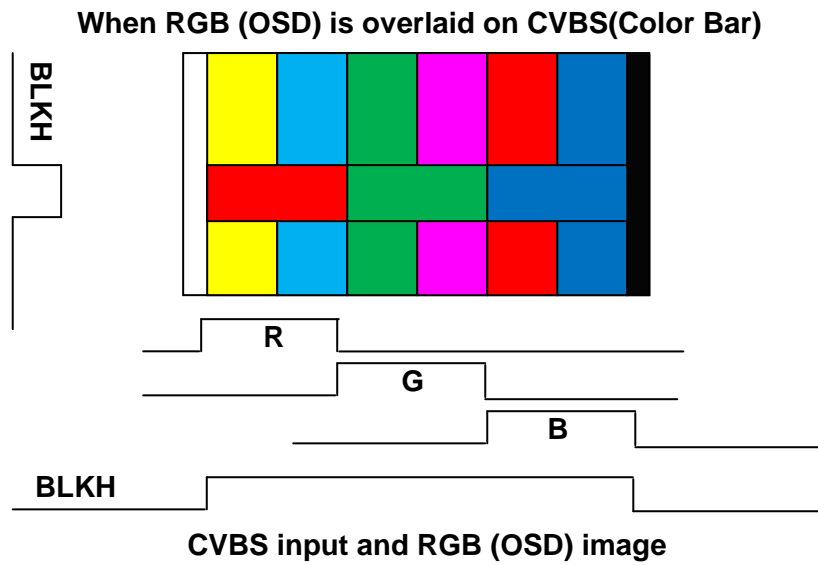

TC90193 has 2 overlay mode of synchronized RGB signal input.

1. Mix1 (Seg:0x00,Sub:0x56,D3:0)

Digital RGB signal is converted to YCbCr, and overlaid on CVBS picture.
 For digital RGB signal, function of video quality improver is available.
 However, half tone process on overlay process is not available.

2. Mix2 (Seg:0x00,Sub:0x56,D3:1)

It overlays the digital RGB signal on the CVBS or ITU-R Bt.656 after the scaler processing in the state of RGB. Also, Halftone process on overlay is available.
 Halftone processing can be set with the BLKH and BLKL pins and registers.

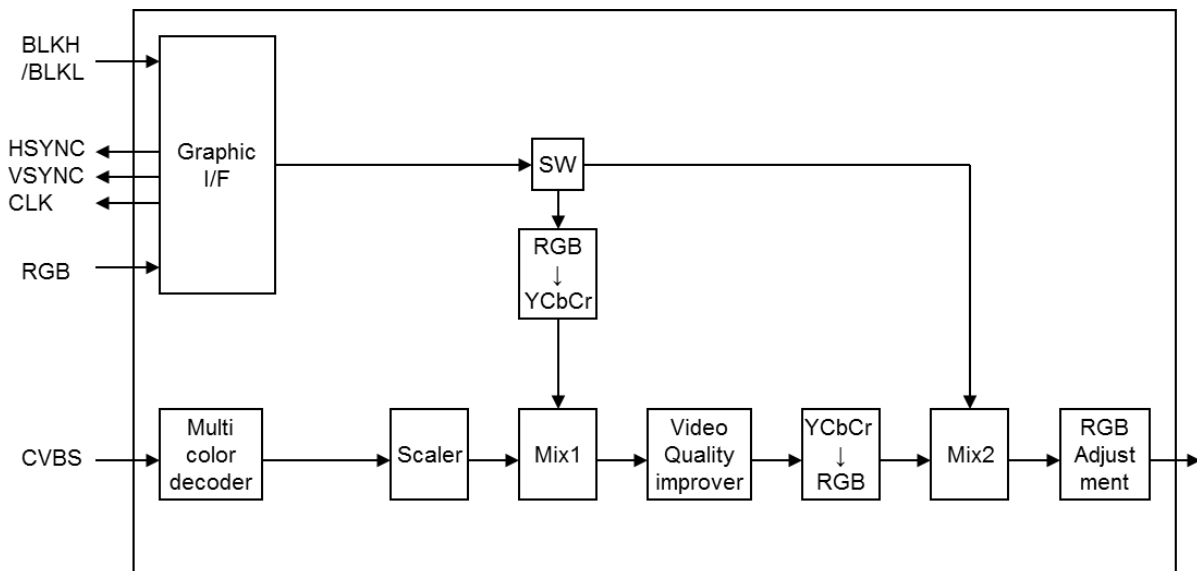

5.2 Video signal output

It outputs digital RGB of the resolution, described in following list.

When digital RGB input, TC90193ASBG outputs digital RGB signal of the resolution same as input signal.

Resolution type	Horizontal effective pixels	Vertical effective pixels
QVGA	320	240
WQVGA	400	234
WQVGA	400	240
WQVGA	480	234
WQVGA	480	240
WQVGA	480	272
VGA	640	480
WVGA	800	480

5.3 Control signals for LCD panel

The Control signals for LCD use the front edge of output active period as a reference point.

There are output possible position setting limitations, when setting output in the forward direction from the front edge of the data enable period.

<Horizontal>

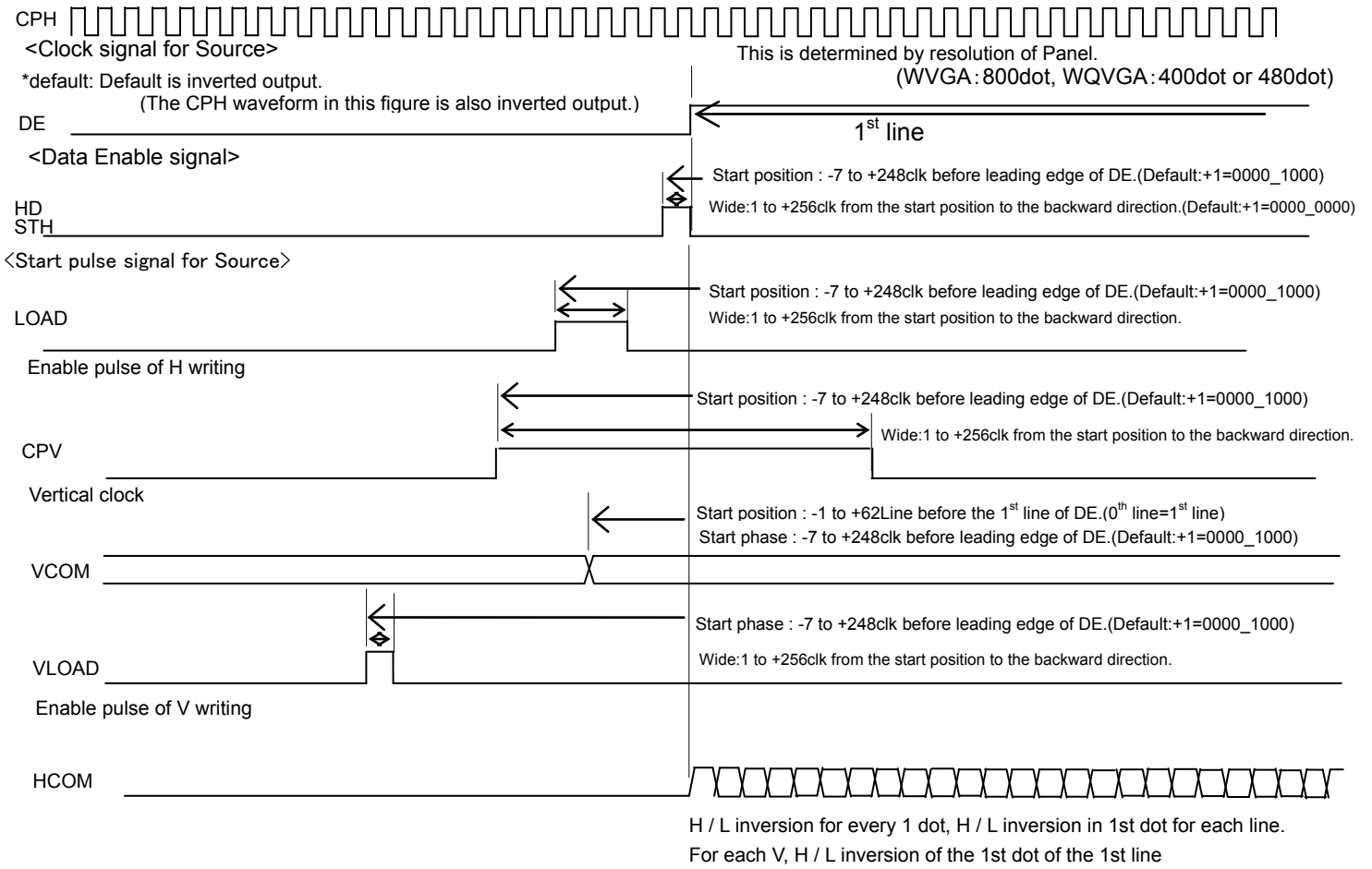

<Vertical>

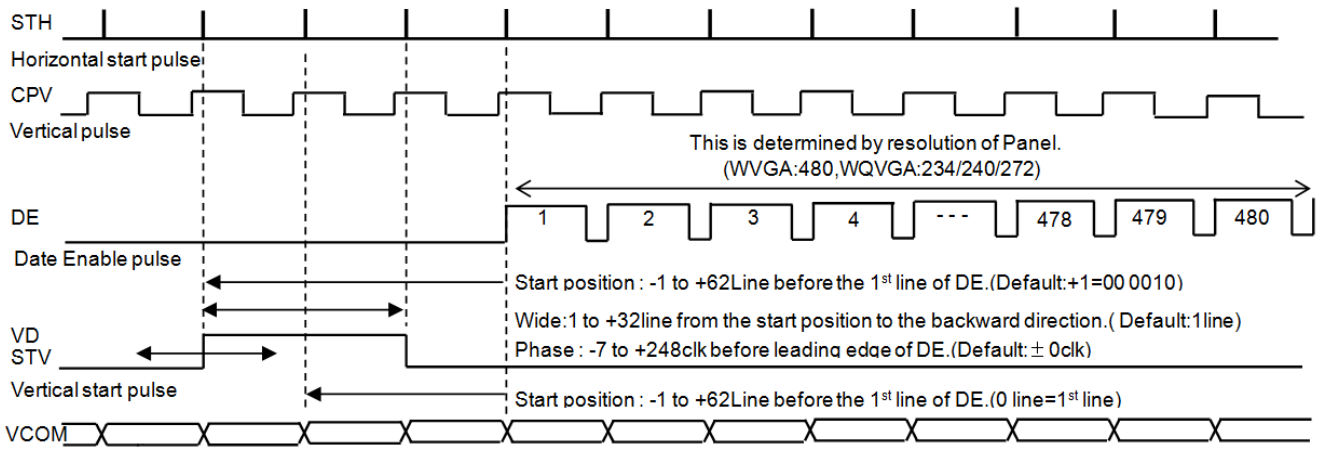

<Power on and start sequence>

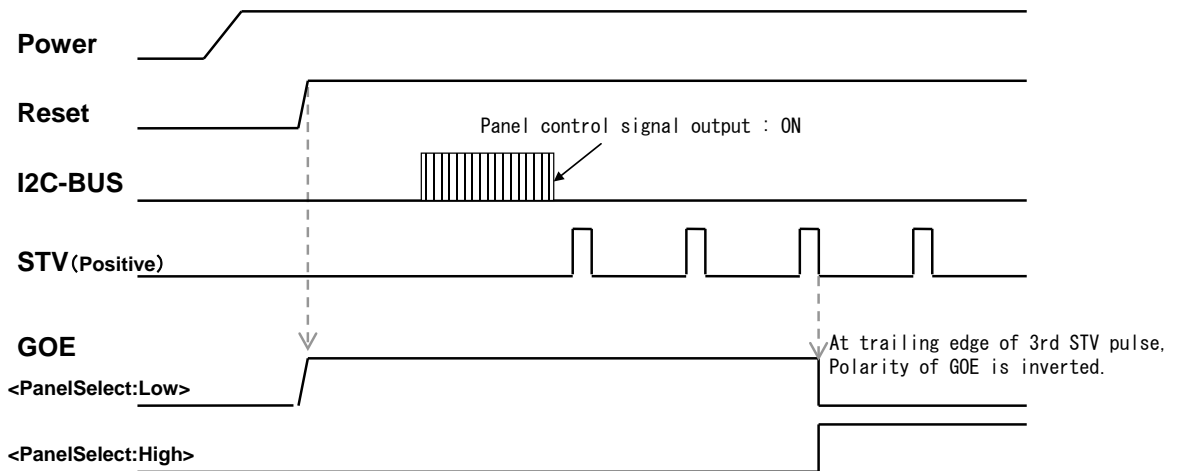

6. Absolute Maximum rating

The absolute maximum ratings are rated values which must not be exceeded during operation, even for an instant. Exceeding the absolute maximum rating may result in destruction, degradation or other damage to the IC and other components.

When designing applications for this IC, be sure that none of the absolute maximum rating values will ever be exceeded.

Item	Corresponding terminal	Symbol	Rating	Unit
Power voltage (1.5V system)	A9,A10,H1,H17,J1,J17,U8,U9	VDD1	-0.3 to VSS+2.0	V
Power voltage (2.5V system)	U12,U14,U15	VDD2	-0.3 to VSS+3.5	V
Power voltage (3.3V system)	A6,A13,A14,D17,E1,N1,N17,U4	VDD3	-0.3 to VSS+3.9	V
Input voltage (3.3V system)	A1,A2,A3,A4,B1,B2,B3,B4,C1,C2,D1,D2,E2,F1,F2,G1,G2,H2,J2,K1,K2,L1,L2,M1,M2,N2,P1,P2,R1,R2,T1,T2,T4,T5,T6,T7,U1,U2,U5,U7	VIN3	-0.3 to VDD3+0.3	V
Input voltage (3.3V system, 5V withstand voltage)	T3,U3,U6	VIN4 (note 1)	-0.3 to VSS+5.5	V
Potential difference between power pins (between 1.5V system power pins)	A9,A10,H1,H17,J1,J17,U8,U9	Δ V _{VG1} (note 2)	0.3	V
Potential difference between power pins (between 2.5V system power pins)	U12,U14,U15	Δ V _{VG2} (note 3)	0.3	V
Potential difference between power pins (between 3.3V system power pins)	A6,A13,A14,D17,E1,N1,N17,U4	Δ V _{VG3} (note 4)	0.3	V
Power dissipation		PD (note 5)	1823	mW
Storage temperature		T _{stg}	-55 to 125	°C

Note1: The withstand voltage for pins(SCL:U3, SDA:T3, RESET:U6) is 5V.

Note2: With the 1.5 VDD terminal group connected (shorted) at the same potential, The maximum potential difference between with the other VDD pin groups should not exceed the rated value. And, keep the maximum potential difference between all VSS pins within 0.01V.

Note3: With the 2.5 VDD terminal group connected (shorted) at the same potential, The maximum potential difference between with the other VDD pin groups should not exceed the rated value. And, keep the maximum potential difference between all VSS pins within 0.01V.

Note4: With the 3.3 VDD terminal group connected (shorted) at the same potential, The maximum potential difference between with the other VDD pin groups should not exceed the rated value. And, keep the maximum potential difference between all VSS pins within 0.01V.

Note5: If using a temperature higher than T_a = 25°C, reduce by 18.23mW per 1°C increase. (When T_a = 85°C, maximum power dissipation is 729mW)

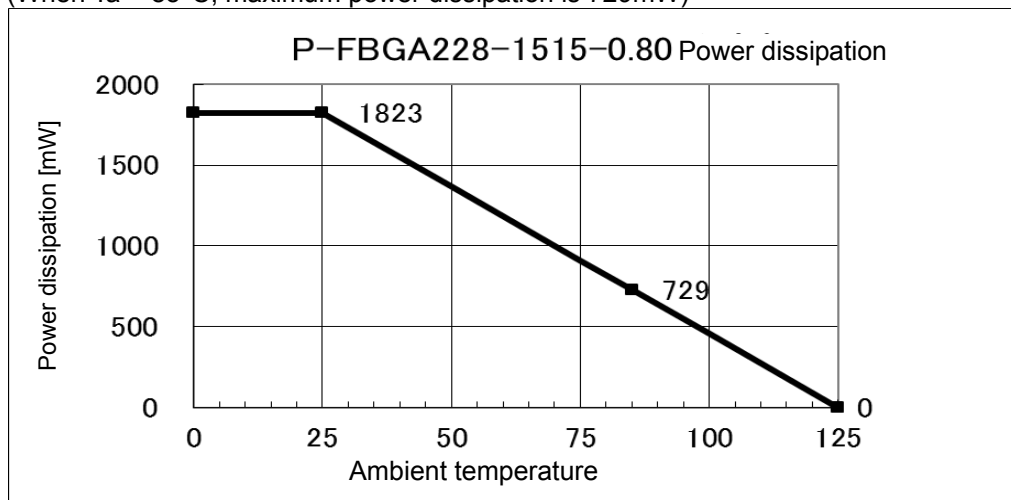

7. Operation Condition

Cannot guarantee operation of TC90193ASBG, when the recommendation power supply voltage range (1.4V-1.6V, 2.3-2.7V, 3.0V-3.6V) is exceeded.

Please use within the specified operating conditions.

Once it returns from the outside of voltage range, it differs from a previous condition.

Therefore, it need to be powered off, and then be powered on again.

Item	Corresponding terminal	Symbol	Min	Typ.	Max	Unit
Power voltage of digital block	A9, A10, H1, H17, J1, J17, U8, U9	VDD-D	1.4	1.5	1.6	V
Power voltage of XO block (note1)	U12	VDD-XO	2.3	2.5	2.7	V
Power voltage of PLL block (note1)	U14	VDD-DA	2.3	2.5	2.7	V
Power voltage of Analog(ADC) block (note1)	U15	VDD-AD	2.3	2.5	2.7	V
Power voltage of I/O block	A6, A13, A14, D17, E1, N1, N17, U4	VDD-IO	3.0	3.3	3.6	V
Operating temperature	-	Topr	-40	-	85	°C

Note1: Please make sure that the power-voltage of three systems (VDD-XO, VDD-DA, VDD-AD) are supplied same electrical potential.

8. Electrical characteristic

8.1 DC characteristic

(Ta=25°C, VDD1=1.50±0.1V, VDD2=2.50±0.2V, VDD3=3.30±0.3V)

Item	Terminal No.	Symbol	Min	Typ.	Max	Unit	Note
Power supply current	A9,A10,H1,H17,J1, J17,U8,U9	IDD1	-	-	150	mA	1.5V system
	U12,U14,U15	IDD2	-	-	75	mA	2.5V system
	A6,A13,A14,D17,E1, N1,N17,U4	IDD3	-	-	100	mA	3.3V system Note.1
Input voltage	A1,A2,A3,A4,B1,B2, B3,B4,C1,C2,D1,D2, E2,F1,F2,G1,G2,H2, J2,K1,K2,L1,L2,M1, M2,N2,P1,P2,R1,R2, T1,T2,T4,T5,T6,T7, U1,U2,U5,U7	VIH	VDD3x0.8	-	VDD3	V	I/O input terminal of 3.3V system
	T3,U3,U6						I/O input terminal of 5V system
	A1,A2,A3,A4,B1,B2, B3,B4,C1,C2,D1,D2, E2,F1,F2,G1,G2,H2, J2,K1,K2,L1,L2,M1, M2,N2,P1,P2,R1,R2, T1,T2,T4,T5,T6,T7, U1,U2,U5,U7	VIL	VSS	-	VDD3x0.2	V	I/O input terminal of 3.3V system
	T3,U3,U6						I/O input terminal of 5V system
Input current	A1,A2,A3,A4,B1,B2, B3,B4,C1,C2,D1,D2, E2,F1,F2,G1,G2,H2, J2,K1,K2,L1,L2,M1, M2,N2,P1,P2,R1,R2, T1,T2,T4,T5,T6,T7, U1,U2,U5,U7	IIH	-10	-	10	μA	I/O input terminal of 3.3V system
	T3,U3,U6						I/O input terminal of 5V system
	A1,A2,A3,A4,B1,B2, B3,B4,C1,C2,D1,D2, E2,F1,F2,G1,G2,H2, J2,K1,K2,L1,L2,M1, M2,N2,P1,P2,R1,R2, T1,T2,T4,T5,T6,T7, U1,U2,U5,U7	IIL	-10	-	10	μA	I/O input terminal of 3.3V system
	T3,U3,U6						I/O input terminal of 5V system

Note.1 : The power supply current of 3.3V systems depends on the load capacity of the LCD panel connected with this IC.

When the load capacity of the LCD panel is large value, the power supply current of 3.3V systems may exceed the above described maximum value.

Item	Terminal No.	Symbol	Min	Typ.	Max	Unit	Note
Output voltage	A5,A7,A8,A11,A12, A15,A16,A17,B5, B6,B7,B8,B9,B10, B11,B12,B13,B14, B15,B16,B17,C16, C17,D16,E16,E17, F16,F17,G16,G17, H16,J16,K17,L16, L17,M16,M17,N16	V_{OH}	VDD3-0.6	-	VDD3	V	I/O output terminal of 3.3V system when load current 4mA
	K16		VDD3-0.6	-	VDD3	V	I/O output terminal of 3.3V system when load current 8mA
	A5,A7,A8,A11,A12, A15,A16,A17,B5, B6,B7,B8,B9,B10, B11,B12,B13,B14, B15,B16,B17,C16, C17,D16,E16,E17, F16,F17,G16,G17, H16,J16,K17,L16, L17,M16,M17,N16 T4,T5	V_{OL}	VSS	-	0.4	V	I/O output terminal of 3.3V system when load current 4mA
	T3,U3		VSS	-	0.4	V	I/O output terminal of 5V system
	K16		VSS	-	0.4	V	I/O output terminal of 3.3V system when load current 8mA

9. Package

P-FBGA228-1515-0.80A5

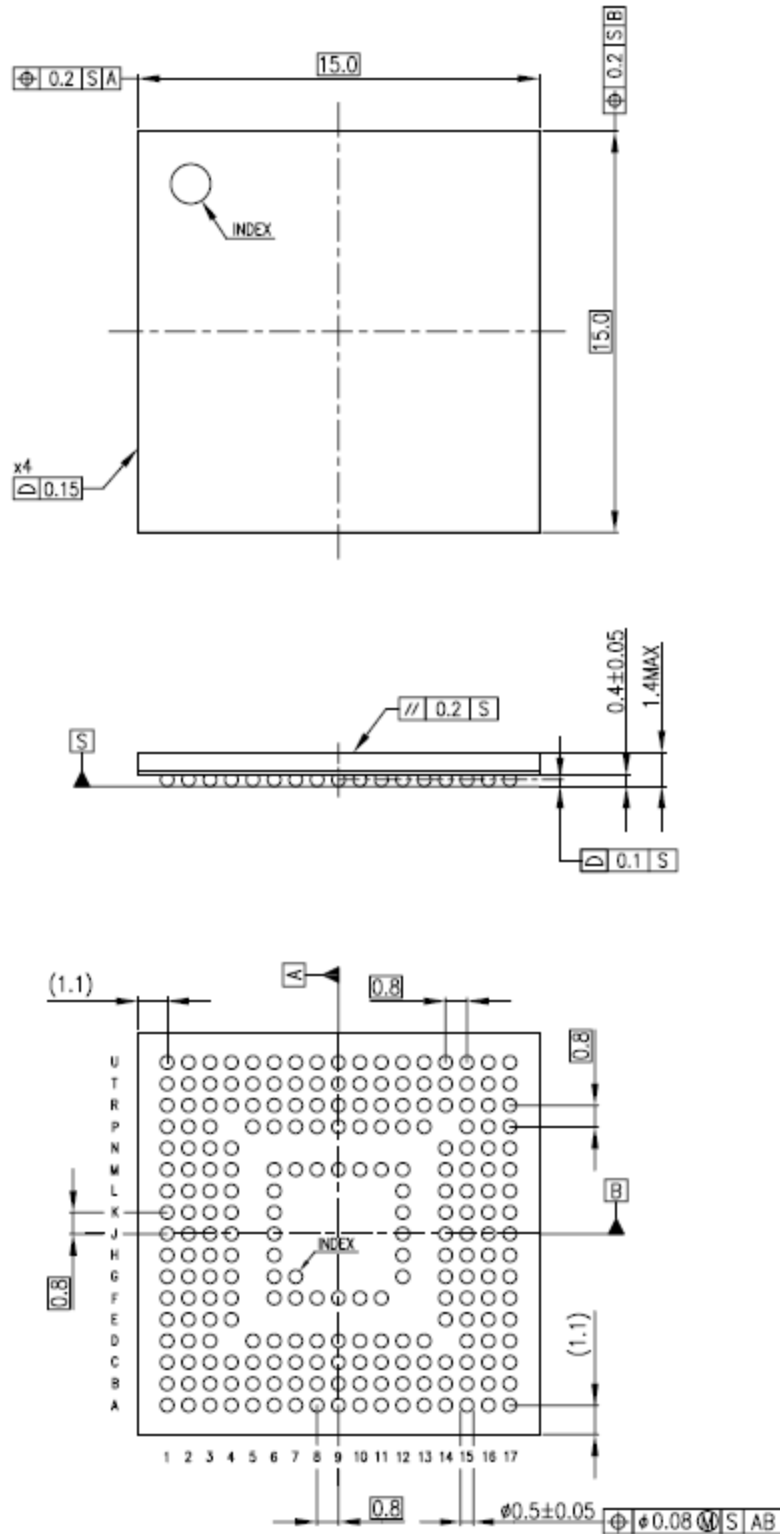

Unit: mm

10. Revision History

Revision	Date	Description
1.00	2017/03/24	First edition

RESTRICTIONS ON PRODUCT USE

- Toshiba Corporation, and its subsidiaries and affiliates (collectively "TOSHIBA"), reserve the right to make changes to the information in this document, and related hardware, software and systems (collectively "Product") without notice.
- This document and any information herein may not be reproduced without prior written permission from TOSHIBA. Even with TOSHIBA's written permission, reproduction is permissible only if reproduction is without alteration/omission.
- Though TOSHIBA works continually to improve Product's quality and reliability, Product can malfunction or fail. Customers are responsible for complying with safety standards and for providing adequate designs and safeguards for their hardware, software and systems which minimize risk and avoid situations in which a malfunction or failure of Product could cause loss of human life, bodily injury or damage to property, including data loss or corruption. Before customers use the Product, create designs including the Product, or incorporate the Product into their own applications, customers must also refer to and comply with (a) the latest versions of all relevant TOSHIBA information, including without limitation, this document, the specifications, the data sheets and application notes for Product and the precautions and conditions set forth in the "TOSHIBA Semiconductor Reliability Handbook" and (b) the instructions for the application with which the Product will be used with or for. Customers are solely responsible for all aspects of their own product design or applications, including but not limited to (a) determining the appropriateness of the use of this Product in such design or applications; (b) evaluating and determining the applicability of any information contained in this document, or in charts, diagrams, programs, algorithms, sample application circuits, or any other referenced documents; and (c) validating all operating parameters for such designs and applications. **TOSHIBA ASSUMES NO LIABILITY FOR CUSTOMERS' PRODUCT DESIGN OR APPLICATIONS.**
- **PRODUCT IS NEITHER INTENDED NOR WARRANTED FOR USE IN EQUIPMENTS OR SYSTEMS THAT REQUIRE EXTRAORDINARILY HIGH LEVELS OF QUALITY AND/OR RELIABILITY, AND/OR A MALFUNCTION OR FAILURE OF WHICH MAY CAUSE LOSS OF HUMAN LIFE, BODILY INJURY, SERIOUS PROPERTY DAMAGE AND/OR SERIOUS PUBLIC IMPACT ("UNINTENDED USE").** Except for specific applications as expressly stated in this document, Unintended Use includes, without limitation, equipment used in nuclear facilities, equipment used in the aerospace industry, medical equipment, equipment used for automobiles, trains, ships and other transportation, traffic signaling equipment, equipment used to control combustions or explosions, safety devices, elevators and escalators, devices related to electric power, and equipment used in finance-related fields. **IF YOU USE PRODUCT FOR UNINTENDED USE, TOSHIBA ASSUMES NO LIABILITY FOR PRODUCT.** For details, please contact your TOSHIBA sales representative.
- Do not disassemble, analyze, reverse-engineer, alter, modify, translate or copy Product, whether in whole or in part.
- Product shall not be used for or incorporated into any products or systems whose manufacture, use, or sale is prohibited under any applicable laws or regulations.
- The information contained herein is presented only as guidance for Product use. No responsibility is assumed by TOSHIBA for any infringement of patents or any other intellectual property rights of third parties that may result from the use of Product. No license to any intellectual property right is granted by this document, whether express or implied, by estoppel or otherwise.
- **ABSENT A WRITTEN SIGNED AGREEMENT, EXCEPT AS PROVIDED IN THE RELEVANT TERMS AND CONDITIONS OF SALE FOR PRODUCT, AND TO THE MAXIMUM EXTENT ALLOWABLE BY LAW, TOSHIBA (1) ASSUMES NO LIABILITY WHATSOEVER, INCLUDING WITHOUT LIMITATION, INDIRECT, CONSEQUENTIAL, SPECIAL, OR INCIDENTAL DAMAGES OR LOSS, INCLUDING WITHOUT LIMITATION, LOSS OF PROFITS, LOSS OF OPPORTUNITIES, BUSINESS INTERRUPTION AND LOSS OF DATA, AND (2) DISCLAIMS ANY AND ALL EXPRESS OR IMPLIED WARRANTIES AND CONDITIONS RELATED TO SALE, USE OF PRODUCT, OR INFORMATION, INCLUDING WARRANTIES OR CONDITIONS OF MERCHANTABILITY, FITNESS FOR A PARTICULAR PURPOSE, ACCURACY OF INFORMATION, OR NONINFRINGEMENT.**
- Do not use or otherwise make available Product or related software or technology for any military purposes, including without limitation, for the design, development, use, stockpiling or manufacturing of nuclear, chemical, or biological weapons or missile technology products (mass destruction weapons). Product and related software and technology may be controlled under the applicable export laws and regulations including, without limitation, the Japanese Foreign Exchange and Foreign Trade Law and the U.S. Export Administration Regulations. Export and re-export of Product or related software or technology are strictly prohibited except in compliance with all applicable export laws and regulations.
- Please contact your TOSHIBA sales representative for details as to environmental matters such as the RoHS compatibility of Product. Please use Product in compliance with all applicable laws and regulations that regulate the inclusion or use of controlled substances, including without limitation, the EU RoHS Directive. **TOSHIBA ASSUMES NO LIABILITY FOR DAMAGES OR LOSSES OCCURRING AS A RESULT OF NONCOMPLIANCE WITH APPLICABLE LAWS AND REGULATIONS.**