

TBD62781A series

Usage considerations

8ch-high active source type DMOS transistor array for level shift circuits and LEDs.

TBD62781A series has an internal pull-down resistor, which is not incorporated in the TBD62783A, in the output unit. When the output is turned off, TBD62781A series does not become in the high impedance state but outputs low level.

Function of transistor array

There are various kinds of transistor arrays depending on their functions.

●Input active level

There are two types. The TBD62781A series are high active type.

Type	Description	TBD62781A
High active	Output is ON by inputting "H" level to input pin.	✓
Low active	Output is ON by inputting "L" level to input pin.	—

●Output clamp diode

There are two types. The TBD62781A series are non-built-in type.

Type	Description	TBD62781A
Built-in	Optimal for driving motors, relays, and solenoids. (Capable of driving LEDs and level shift circuits.)	—
Non-built-in	Optimal for driving LEDs and level shift circuits. (External diodes are required to drive motors, relays, and solenoids.)	✓

●Output current system

There are two types. The TBD62781A series are source type. Connecting point of each load is different.

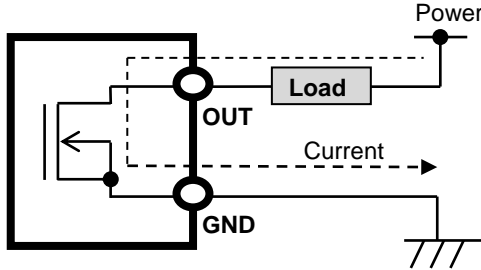
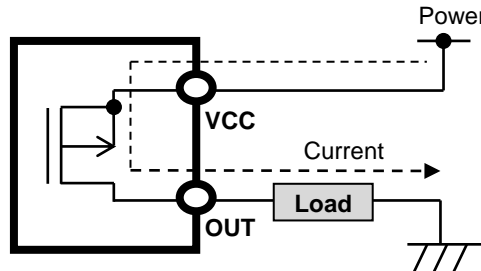
Type	Description	TBD62781A
Sink type	Output of current sink type (output pull) 	—
Source type	Output of current source type (output push) 	✓

Application example

Dynamic drive control is possible by combining transistor arrays of the sink type and the source type.

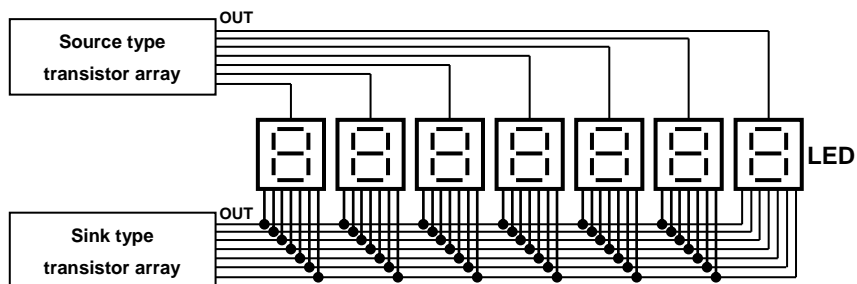

●Construction of output circuit

There are three types. The TBD62781A series are DMOS FET type.

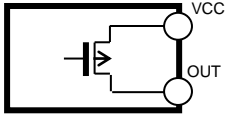
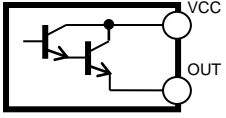
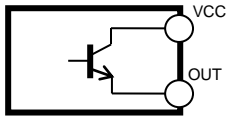
Type	Description	TBD62781A
DMOS FET type	 <p>Features Large current drive is possible. Loss in low current range is reduced.</p>	✓
Bipolar transistor Darlington type	 <p>Features Large current drive is possible.</p>	—
Bipolar transistor Single type	 <p>Features Loss in low current range is reduced.</p>	—

Characteristics graph of each type (for reference only)

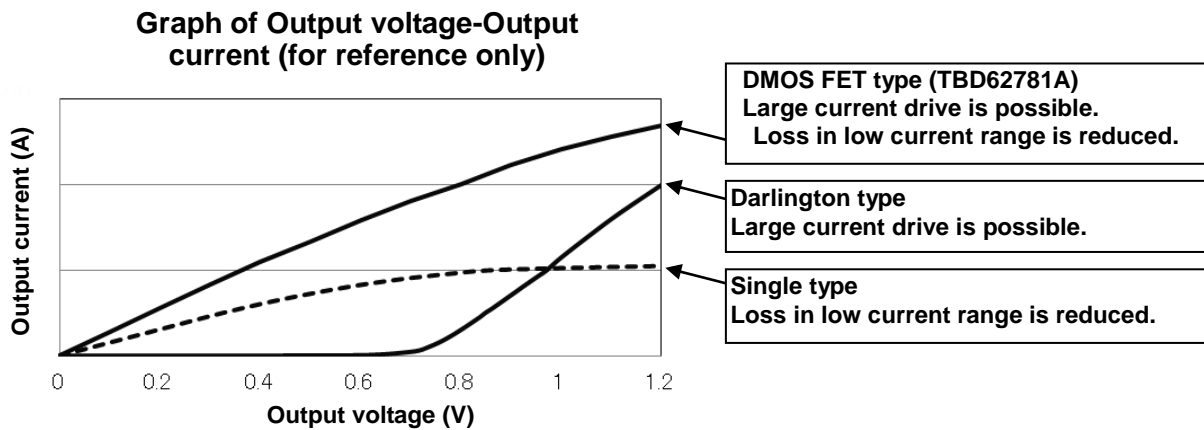

Basic circuit

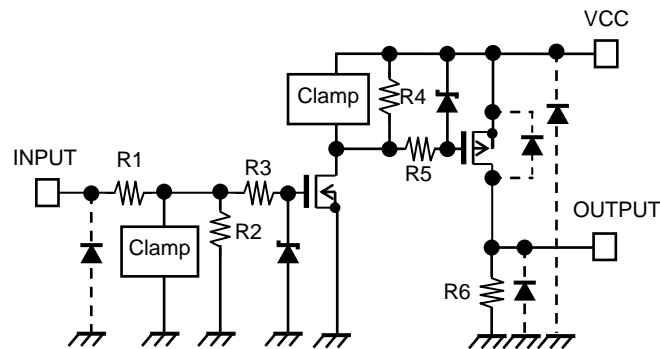

- * Constant number of internal resistance: R1=25.5 kΩ (typ.), R2=1 MΩ (typ.), R3=6 kΩ (typ.), R4=12 kΩ (typ.), R5=6 kΩ (typ.), and R6=200 kΩ (typ.)
- * The accuracy of the internal resistance is ±30% (reference value).
- * V_a is clamped up to about 4 V by the clamp circuit.

Above basic circuit diagram may be omitted or simplified for explanatory purposes.

●Control of output ON/OFF

Outputs of the TBD62781A series are constructed by DMOS FET. ON/OFF of output is controlled according to the applied voltage of the input pin.

Product	VIN(ON)	VIN(OFF)
TBD62781A series	2.0 V to 25 V	0 V to 0.6 V

When VCC is supplied through the external pull-up resistor, the voltage for VIN (ON) in the above table should be applied by considering the voltage drop occurred by the external resistor (R_{up}).

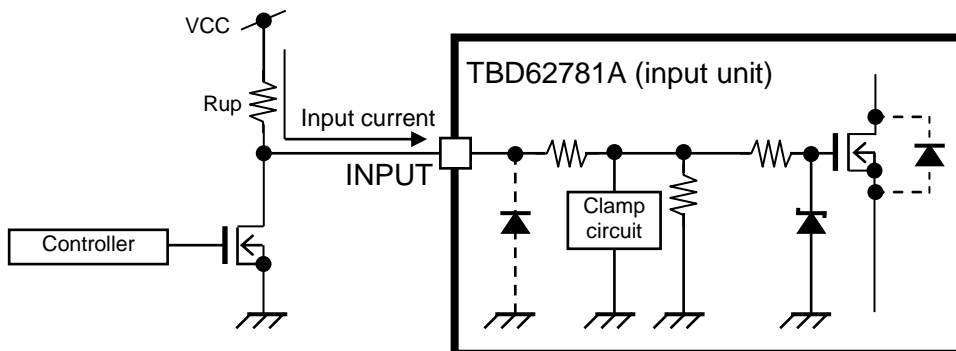

●Usage considerations for unused channel pins

Unused channel pins are recommended to be treated as follows;

Pin	Connection treatments
I1, I2, I3, I4, I5, I6, I7, and I8	Input pins are pulled down and outputs are turned off during open state. Connecting input pins to the GND pin is recommended to prevent IC malfunctions due to noise.
O1, O2, O3, O4, O5, O6, O7, and O8	Open state or GND connection is recommended. When the IC is used under high noise intensity, connecting to GND may have the higher noise tolerance (including ESD surge) than the open state according to the wiring state. Therefore, in designing, it is recommended to compare the noise tolerance between them.

Application circuit example

- Resistive load drive

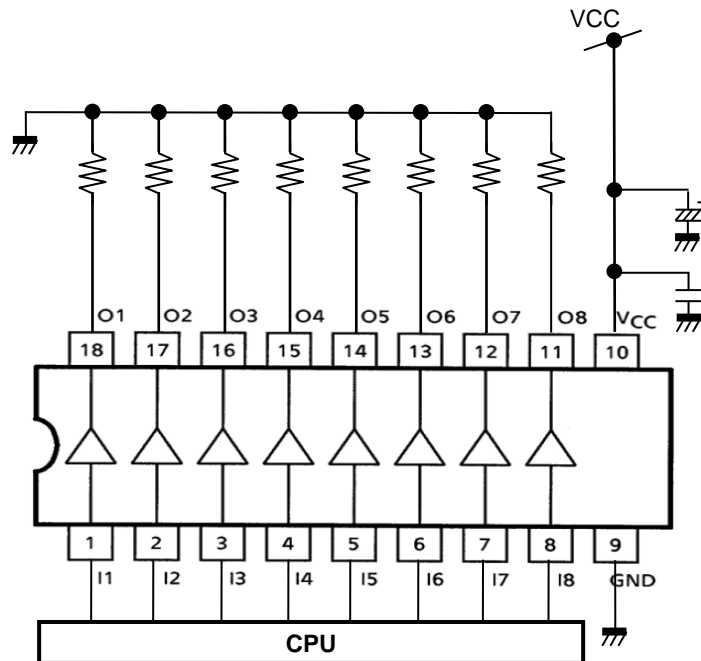

For voltage stabilization and noise rejection, please connect a stacked ceramic capacitor (0.01 μF to 1 μF) or an electrolytic capacitor (10 μF to 100 μF) to VCC line. The capacitor is recommended to be connected as close to the IC as possible.

- Photo coupler drive

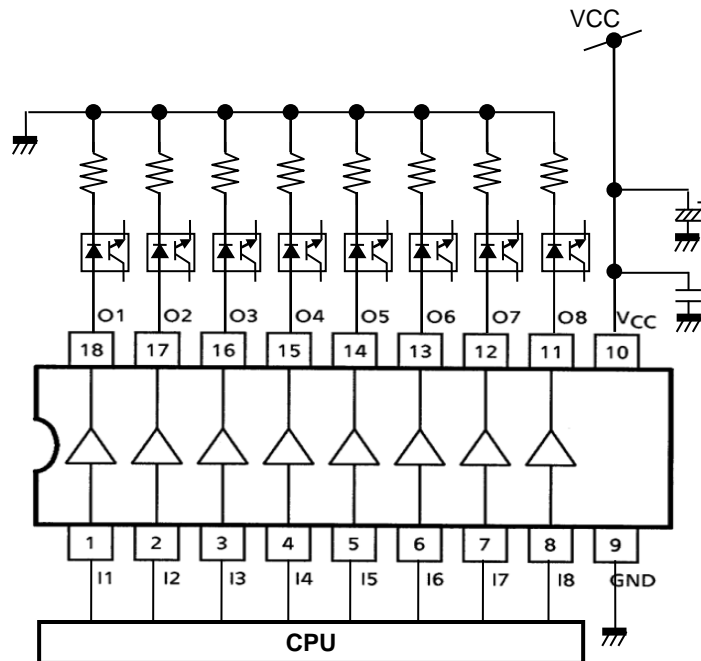

For voltage stabilization and noise rejection, please connect a stacked ceramic capacitor (0.01 μF to 1 μF) or an electrolytic capacitor (10 μF to 100 μF) to VCC line. The capacitor is recommended to be connected as close to the IC as possible.

- Dynamic drive: 7-segment LED combined with the TBD62083A.

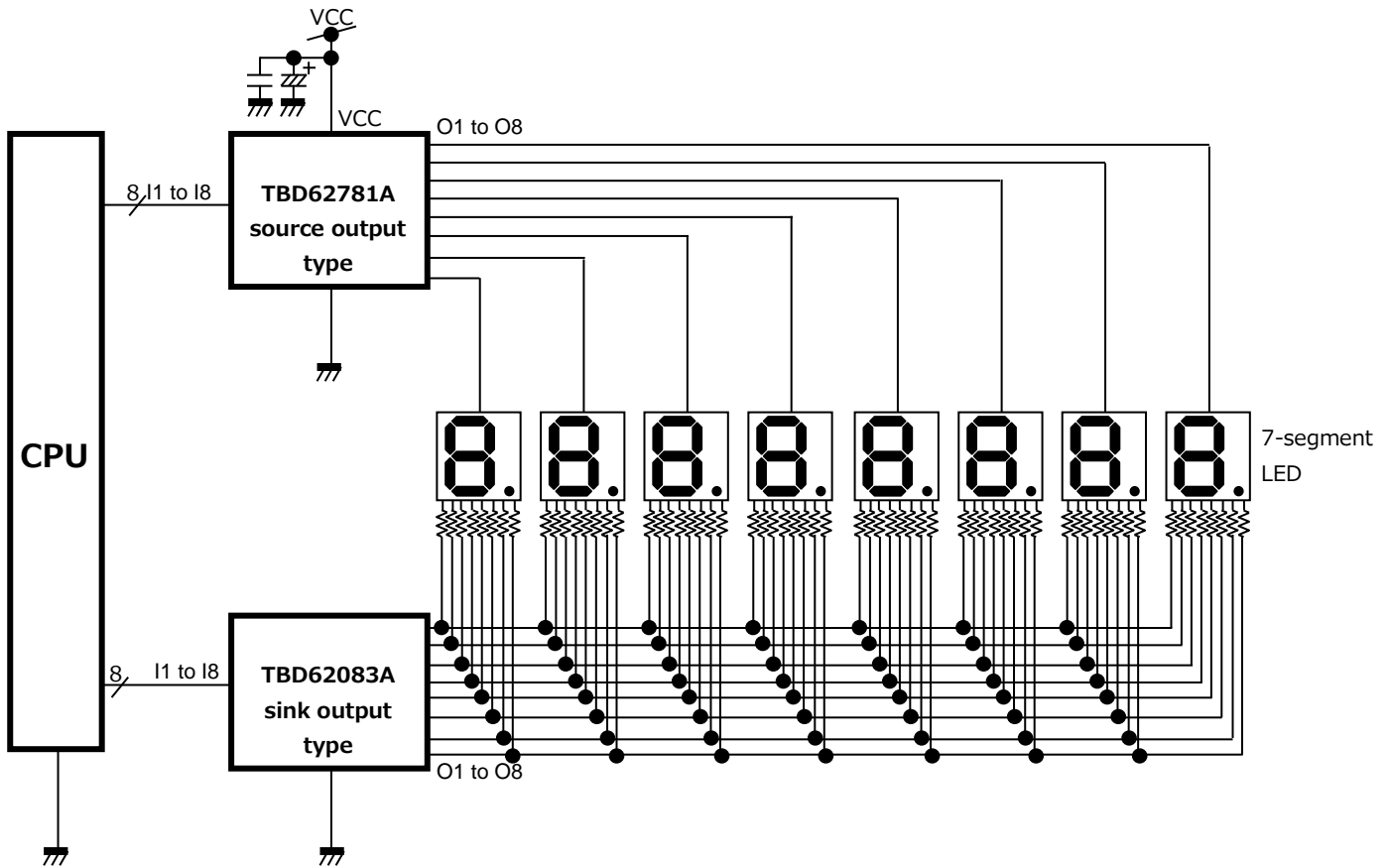

For voltage stabilization and noise rejection, please connect a stacked ceramic capacitor (0.01 μF to 1 μF) or an electrolytic capacitor (10 μF to 100 μF) to VCC line. The capacitor is recommended to be connected as close to the IC as possible.

Noise reduction (including ESD surge measurement)

When a noise (including ESD surge) is applied on the input and output pins of the IC, the IC or other components will be damaged or fail.

Generally, noise (including ESD surge) tolerance is improved by connecting series resistors, a CR filter, and an ESD protection diode to the input pins, by connecting an ESD protection diode to the output pins, and by connecting a multilayer ceramic capacitor close to VCC pin.

(Example) Connect series resistors to the input pin

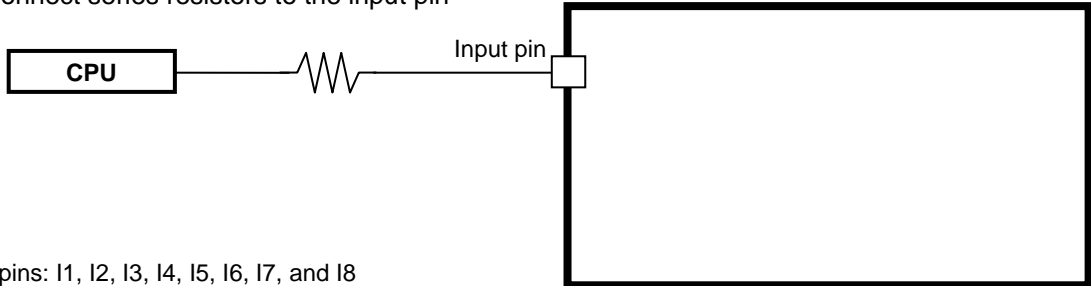

Input pins: I1, I2, I3, I4, I5, I6, I7, and I8

(Example) Connect a CR filter to the input pin

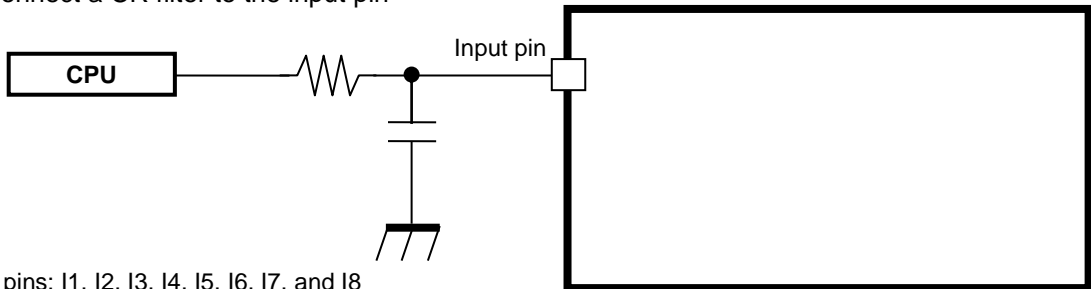

Input pins: I1, I2, I3, I4, I5, I6, I7, and I8

(Example) Connect an ESD protection diode to the input pin

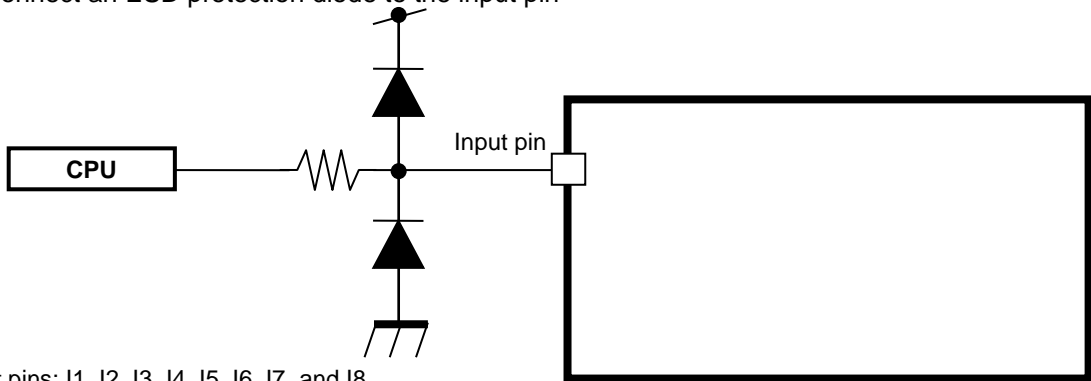

Input pins: I1, I2, I3, I4, I5, I6, I7, and I8

(Example) Connect an ESD protection diode to the output pin

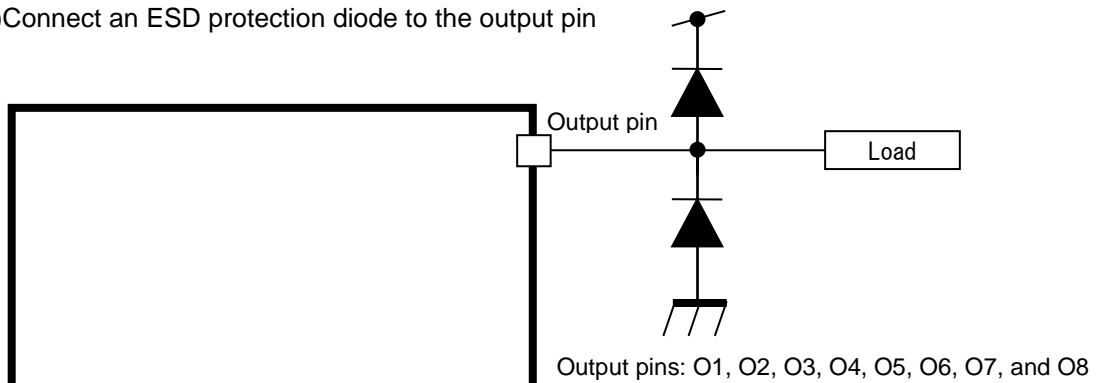

Output pins: O1, O2, O3, O4, O5, O6, O7, and O8

(Example) Connect a multilayer ceramic capacitor close to VCC pin

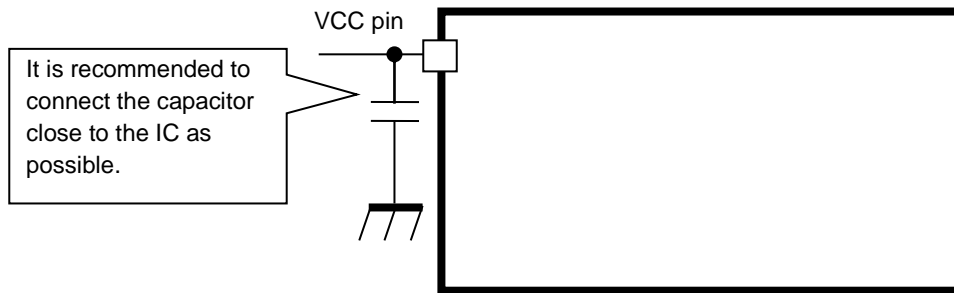

Loss calculation of the IC

In using the IC, take enough margins for each configuration by calculating the loss of the IC from below formula and by referring to the PD-Ta graph.

•Loss calculation

- Output block
 $P_{out}(W) = I_{OUT}(A) \times I_{OUT}(A) \times R_{ON}(\Omega) \times ONDuty \times \text{number of driving channels}$
- Input block
 $P_{in}(W) = I_{IN}(A) \times V_{IN}(V) \times ONDuty \times \text{number of driving channels}$
- VCC
 $P_{vcc}(W) = I_{CC}(A) \times V_{CC}(V) \times \text{number of driving channels}$
- Whole IC
 $PD(W) = P_{out}(W) + P_{in}(W) + P_{vcc}(W)$

* RON, ICC, and IIN: Please refer to 'Electrical characteristics' in the data sheet.

* ONDuty: Please adopt ON term/cycle. However, when ON term is 25 ms or more, please adopt 'ONDuty=1'.

•PD-Ta graph

Conditions: Absolute maximum rating of the junction temperature (Tj) is 150°C.

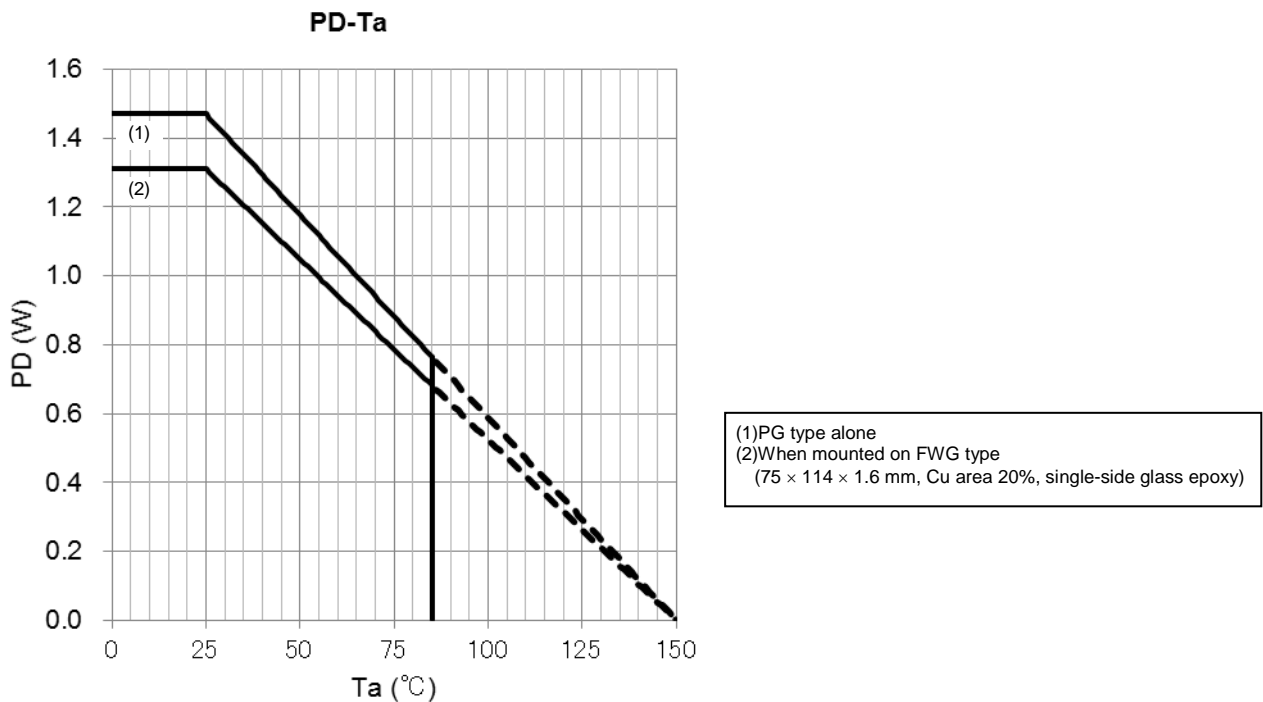

•Thermal resistance (for reference only)

PG type : Rth(j-a) = 85°C/W (standalone)

FWG type : Rth(j-a) = 95°C/W (when mounted on 75 × 114 × 1.6 mm, Cu area 20%, single-side glass epoxy)

Reference data

* The data is for reference, not guaranteed.

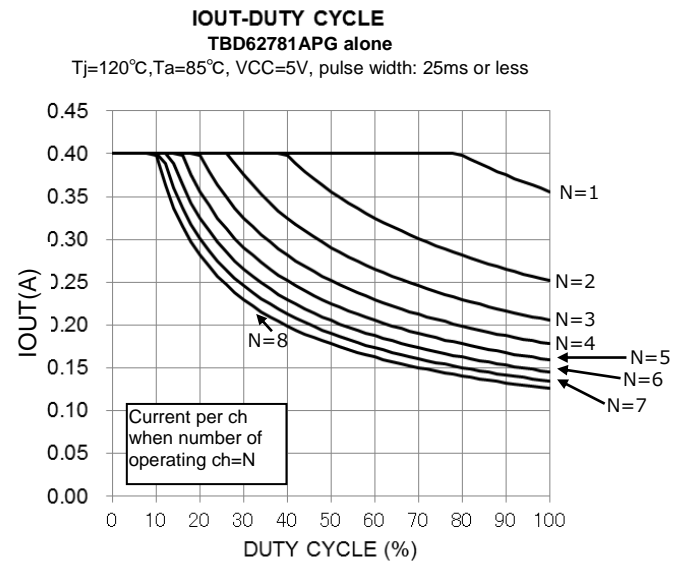
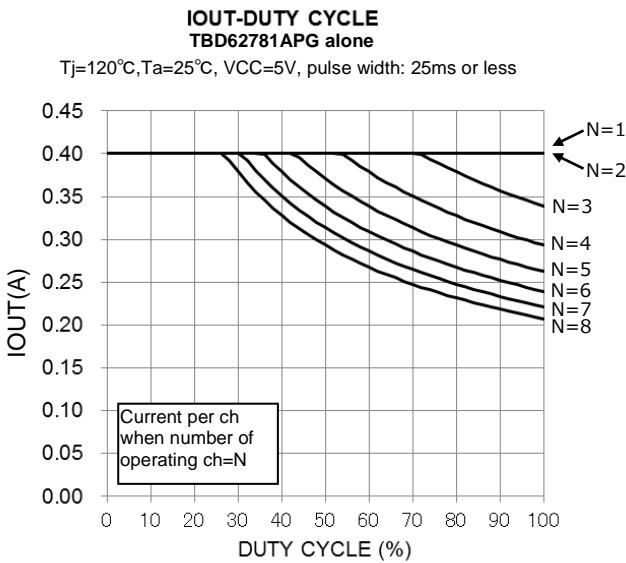
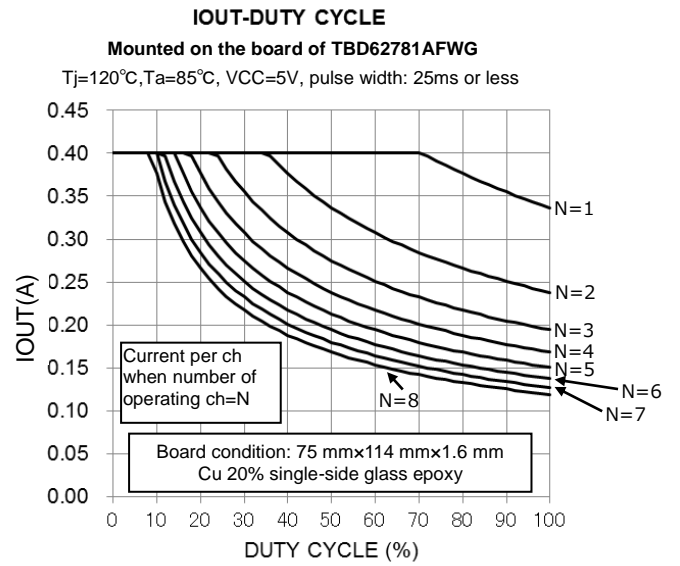
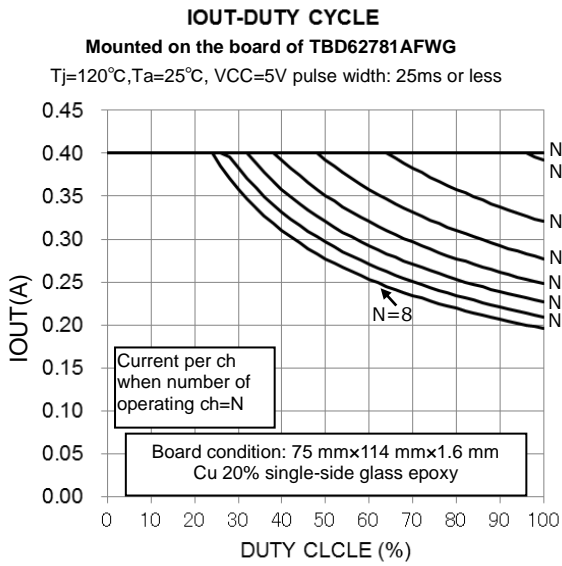

* The data is for reference, not guaranteed.

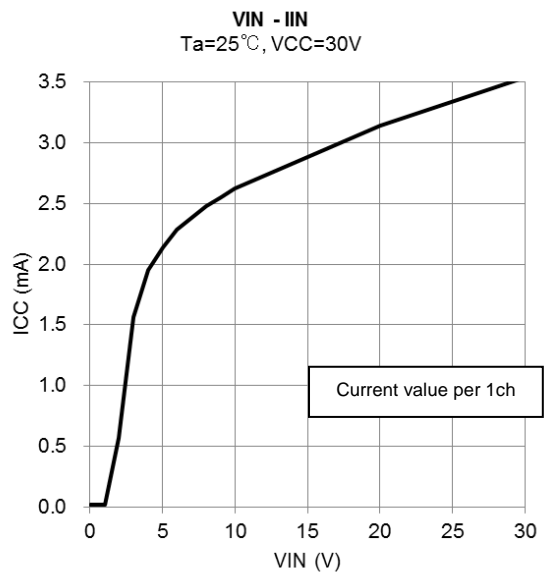
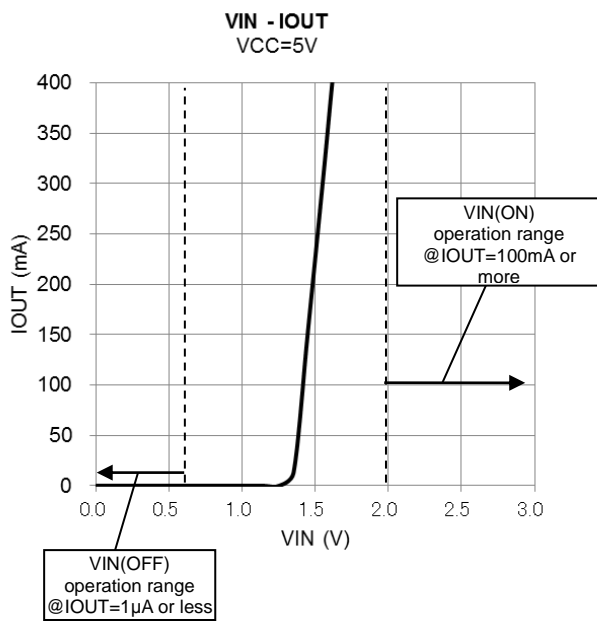
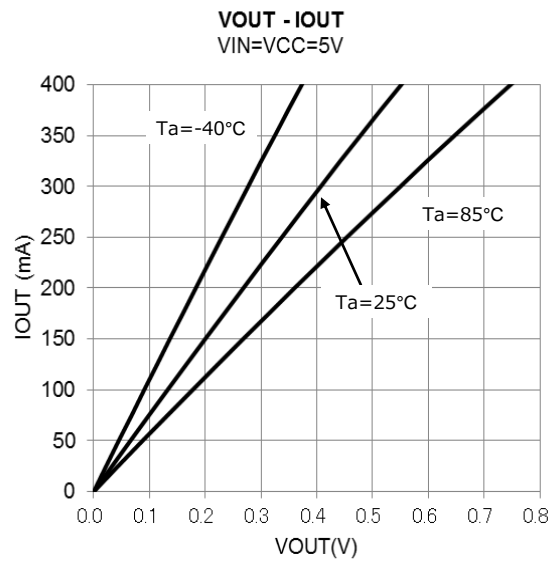
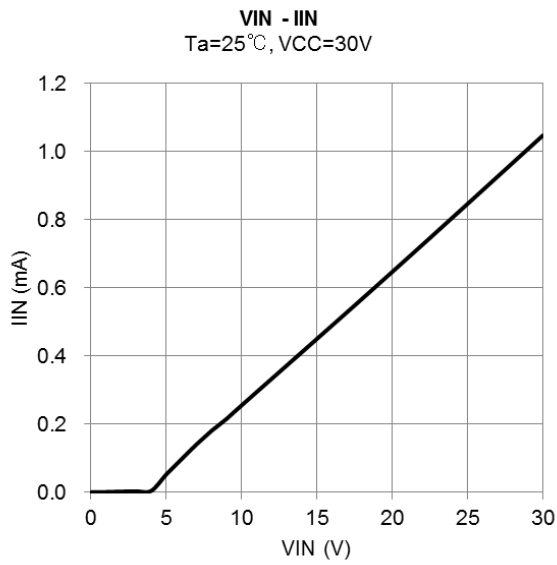

Notes on Contents

1. Pin Connection Diagrams

The pin connection diagrams may be simplified or some parts of them may be omitted for explanatory purposes.

2. Basic Circuits

The basic circuit diagrams may be simplified or some parts of them may be omitted for explanatory purposes.

3. Test Circuits

The test circuit diagrams may be simplified or some parts of them may be omitted for explanatory purposes.

4. Timing Charts

Timing charts may be simplified or some parts of them may be omitted for explanatory purposes.

IC Usage Considerations

Notes on handling of ICs

- [1] The absolute maximum ratings of a semiconductor device are a set of ratings that must not be exceeded, even for a moment. Do not exceed any of these ratings.
Exceeding the rating(s) may cause the device breakdown, damage or deterioration, and may result injury by explosion or combustion.
- [2] Do not insert devices in the wrong orientation or incorrectly.
Make sure that the positive and negative terminals of power supplies are connected properly.
Otherwise, the current or power consumption may exceed the absolute maximum rating, and exceeding the rating(s) may cause the device breakdown, damage or deterioration, and may result injury by explosion or combustion.
In addition, do not use any device that is applied the current with inserting in the wrong orientation or incorrectly even just one time.
- [3] Use an appropriate power supply fuse to ensure that a large current does not continuously flow in case of over current and/or IC failure. The IC will fully break down when used under conditions that exceed its absolute maximum ratings, when the wiring is routed improperly or when an abnormal pulse noise occurs from the wiring or load, causing a large current to continuously flow and the breakdown can lead smoke or ignition. To minimize the effects of the flow of a large current in case of breakdown, appropriate settings, such as fuse capacity, fusing time and insertion circuit location, are required.
- [4] If your design includes an inductive load such as a motor coil, incorporate a protection circuit into the design to prevent device malfunction or breakdown caused by the current resulting from the inrush current at power ON or the negative current resulting from the back electromotive force at power OFF. IC breakdown may cause injury, smoke or ignition.
Use a stable power supply with ICs with built-in protection functions. If the power supply is unstable, the protection function may not operate, causing IC breakdown. IC breakdown may cause injury, smoke or ignition.
- [5] Carefully select external components (such as inputs and negative feedback capacitors) and load components (such as speakers), for example, power amp and regulator.
If there is a large amount of leakage current such as input or negative feedback condenser, the IC output DC voltage will increase. If this output voltage is connected to a speaker with low input withstand voltage, overcurrent or IC failure can cause smoke or ignition. (The over current can cause smoke or ignition from the IC itself.) In particular, please pay attention when using a Bridge Tied Load (BTL) connection type IC that inputs output DC voltage to a speaker directly.

Points to remember on handling of ICs

Heat Radiation Design

In using an IC with large current flow such as power amp, regulator or driver, please design the device so that heat is appropriately radiated, not to exceed the specified junction temperature (T_j) at any time and condition. These ICs generate heat even during normal use. An inadequate IC heat radiation design can lead to decrease in IC life, deterioration of IC characteristics or IC breakdown. In addition, please design the device taking into considerate the effect of IC heat radiation with peripheral components.

Back-EMF

When a motor rotates in the reverse direction, stops or slows down abruptly, a current flow back to the motor's power supply due to the effect of back-EMF. If the current sink capability of the power supply is small, the device's motor power supply and output pins might be exposed to conditions beyond absolute maximum ratings. To avoid this problem, take the effect of back-EMF into consideration in system design.

RESTRICTIONS ON PRODUCT USE

Toshiba Corporation and its subsidiaries and affiliates are collectively referred to as "TOSHIBA". Hardware, software and systems described in this document are collectively referred to as "Product".

- TOSHIBA reserves the right to make changes to the information in this document and related Product without notice.
- This document and any information herein may not be reproduced without prior written permission from TOSHIBA. Even with TOSHIBA's written permission, reproduction is permissible only if reproduction is without alteration/omission.
- Though TOSHIBA works continually to improve Product's quality and reliability, Product can malfunction or fail. Customers are responsible for complying with safety standards and for providing adequate designs and safeguards for their hardware, software and systems which minimize risk and avoid situations in which a malfunction or failure of Product could cause loss of human life, bodily injury or damage to property, including data loss or corruption. Before customers use the Product, create designs including the Product, or incorporate the Product into their own applications, customers must also refer to and comply with (a) the latest versions of all relevant TOSHIBA information, including without limitation, this document, the specifications, the data sheets and application notes for Product and the precautions and conditions set forth in the "TOSHIBA Semiconductor Reliability Handbook" and (b) the instructions for the application with which the Product will be used with or for. Customers are solely responsible for all aspects of their own product design or applications, including but not limited to (a) determining the appropriateness of the use of this Product in such design or applications; (b) evaluating and determining the applicability of any information contained in this document, or in charts, diagrams, programs, algorithms, sample application circuits, or any other referenced documents; and (c) validating all operating parameters for such designs and applications. **TOSHIBA ASSUMES NO LIABILITY FOR CUSTOMERS' PRODUCT DESIGN OR APPLICATIONS.**
- **PRODUCT IS NEITHER INTENDED NOR WARRANTED FOR USE IN EQUIPMENTS OR SYSTEMS THAT REQUIRE EXTRAORDINARILY HIGH LEVELS OF QUALITY AND/OR RELIABILITY, AND/OR A MALFUNCTION OR FAILURE OF WHICH MAY CAUSE LOSS OF HUMAN LIFE, BODILY INJURY, SERIOUS PROPERTY DAMAGE AND/OR SERIOUS PUBLIC IMPACT ("UNINTENDED USE").** Except for specific applications as expressly stated in this document, Unintended Use includes, without limitation, equipment used in nuclear facilities, equipment used in the aerospace industry, medical equipment, equipment used for automobiles, trains, ships and other transportation, traffic signaling equipment, equipment used to control combustions or explosions, safety devices, elevators and escalators, devices related to electric power, and equipment used in finance-related fields. **IF YOU USE PRODUCT FOR UNINTENDED USE, TOSHIBA ASSUMES NO LIABILITY FOR PRODUCT.** For details, please contact your TOSHIBA sales representative.
- Do not disassemble, analyze, reverse-engineer, alter, modify, translate or copy Product, whether in whole or in part.
- Product shall not be used for or incorporated into any products or systems whose manufacture, use, or sale is prohibited under any applicable laws or regulations.
- The information contained herein is presented only as guidance for Product use. No responsibility is assumed by TOSHIBA for any infringement of patents or any other intellectual property rights of third parties that may result from the use of Product. No license to any intellectual property right is granted by this document, whether express or implied, by estoppel or otherwise.
- **ABSENT A WRITTEN SIGNED AGREEMENT, EXCEPT AS PROVIDED IN THE RELEVANT TERMS AND CONDITIONS OF SALE FOR PRODUCT, AND TO THE MAXIMUM EXTENT ALLOWABLE BY LAW, TOSHIBA (1) ASSUMES NO LIABILITY WHATSOEVER, INCLUDING WITHOUT LIMITATION, INDIRECT, CONSEQUENTIAL, SPECIAL, OR INCIDENTAL DAMAGES OR LOSS, INCLUDING WITHOUT LIMITATION, LOSS OF PROFITS, LOSS OF OPPORTUNITIES, BUSINESS INTERRUPTION AND LOSS OF DATA, AND (2) DISCLAIMS ANY AND ALL EXPRESS OR IMPLIED WARRANTIES AND CONDITIONS RELATED TO SALE, USE OF PRODUCT, OR INFORMATION, INCLUDING WARRANTIES OR CONDITIONS OF MERCHANTABILITY, FITNESS FOR A PARTICULAR PURPOSE, ACCURACY OF INFORMATION, OR NONINFRINGEMENT.**
- Do not use or otherwise make available Product or related software or technology for any military purposes, including without limitation, for the design, development, use, stockpiling or manufacturing of nuclear, chemical, or biological weapons or missile technology products (mass destruction weapons). Product and related software and technology may be controlled under the applicable export laws and regulations including, without limitation, the Japanese Foreign Exchange and Foreign Trade Law and the U.S. Export Administration Regulations. Export and re-export of Product or related software or technology are strictly prohibited except in compliance with all applicable export laws and regulations.
- Please contact your TOSHIBA sales representative for details as to environmental matters such as the RoHS compatibility of Product. Please use Product in compliance with all applicable laws and regulations that regulate the inclusion or use of controlled substances, including without limitation, the EU RoHS Directive. **TOSHIBA ASSUMES NO LIABILITY FOR DAMAGES OR LOSSES OCCURRING AS A RESULT OF NONCOMPLIANCE WITH APPLICABLE LAWS AND REGULATIONS.**