

TOSHIBA CMOS Linear Integrated Circuit Silicon Monolithic

TCK401G, TCK402G

External FET Driver IC

The TCK401G and TCK402G are 28 V high input voltage External FET driver ICs. They have wide input voltage range. And they feature a slew rate control driver with small package WCSP6E (0.8 mm x 1.2 mm, t: 0.55 mm). Also they can block reverse current if switch turned off by using external series FET. Thus they are suitable for power management selector such as Battery Charge application.

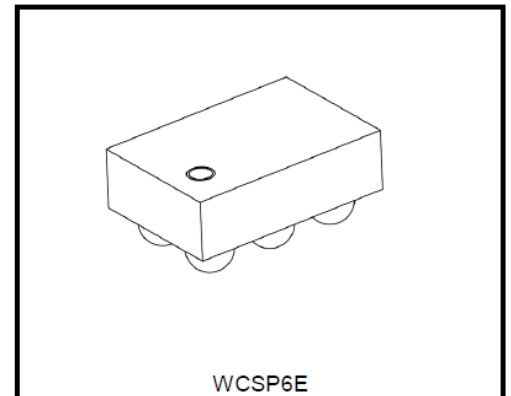

Weight: 1 mg(typ.)

Feature

- High maximum input voltage: $V_{IN\ max} = 40\ V$
- Wide input voltage range: $V_{IN} = 2.7\ to\ 28\ V$
- Auto output discharge
- Charge pump circuit
- Inrush current reducing circuit.
- Over voltage lock out (Over 28 V)
- Under voltage lock out (Under 2.7 V)
- Reverse current protection by External Back to Back MOSFET

Top marking (Top view)

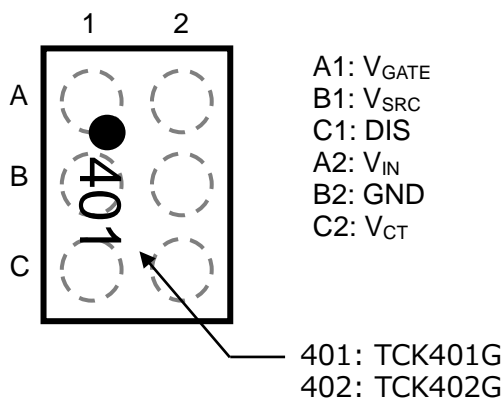

Start of commercial production
2017-10

• Absolute Maximum Ratings (Ta = 25°C)

Characteristics	Symbol	Rating	Unit
Input voltage	V _{IN}	-0.3 to 40	V
Control voltage	V _{CT}	-0.3 to 6	V
Output GATE voltage	V _{GATE}	-0.3 to V _{IN_opr} + V _{GS}	V
SRC voltage	V _{SRC}	-0.3 to V _{GATE}	V
DIS voltage	V _{DIS}	-0.3 to 40	V
Power dissipation	P _D	800 (Note 1)	mW
Operating temperature range	T _{opr}	-40 to 85	°C
Junction temperature	T _j	150	°C
Storage temperature	T _{stg}	-55 to 150	°C

Note: Using continuously under heavy loads (e.g. the application of high temperature/current/voltage and the significant change in temperature, etc.) may cause this product to decrease in the reliability significantly even if the operating conditions (i.e. operating temperature/current/voltage, etc.) are within the absolute maximum ratings. Please design the appropriate reliability upon reviewing the Toshiba Semiconductor Reliability Handbook ("Handling Precautions"/"Derating Concept and Methods") and individual reliability data (i.e. reliability test report and estimated failure rate, etc).

Note1: Rating at mounting on a board: FR4 board. (40 mm × 40 mm × 1.6 mm, Cu 4 layer)

• Operating Conditions

Characteristics	Symbol	Min.	Typ.	Max.	Unit
Input operation voltage	V _{IN_opr}	2.7	5.0	28	V
Capacitance	C _{IN}	0.1	1	—	μF
	C _{GATE}	—	2000	—	pF
CONTROL High-level input voltage	V _{IH}	1.6	—	—	V
CONTROL Low-level input voltage	V _{IL}	—	—	0.4	V

- Pin Assignment (Top view)

- WCSP6E

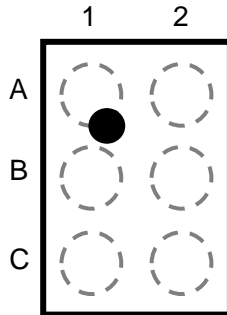

Pin #	Name	Pin #	Name
A1	V _{GATE}	A2	V _{IN}
B1	V _{SRC}	B2	GND
C1	DIS	C2	V _{CT}

- Product list

Part number	VCT function	VCT resistance
TCK401G	Active High	Pull down
TCK402G	Active Low	Pull down

- Block Diagram

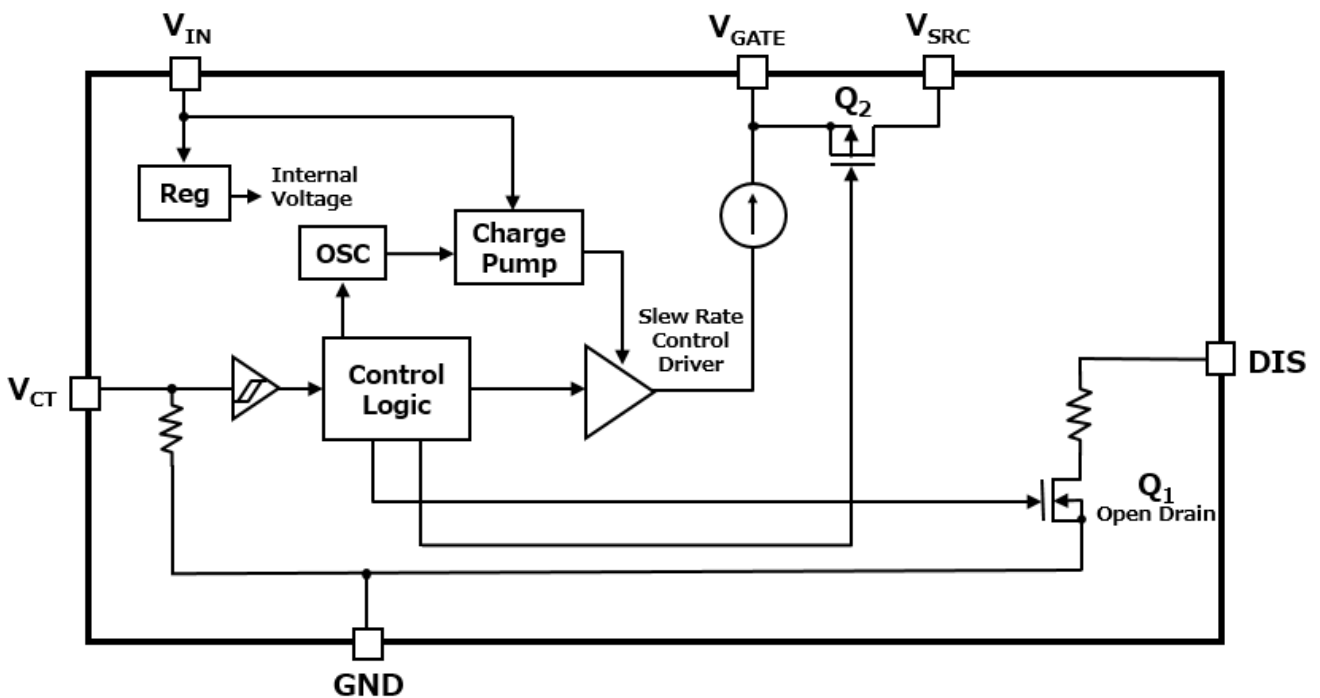

TCK401G PIN Description

PIN	Name	Description
A1	V _{GATE}	Gate-Driver Output.
A2	V _{IN}	Supply voltage input.
B1	V _{SRC}	Recommend connecting V _{SRC} terminal to the common source connection of the external MOSFETs.
B2	GND	Ground
C1	DIS	Output Discharge terminal.
C2	V _{CT}	Mode control input terminal. When V _{CT} =High turn the external MOSFETs on, V _{CT} =Low, turn the external MOSFETs off.

- **TCK402G PIN Description**

PIN	Name	Description
A1	V _{GATE}	Gate-Driver Output.
A2	V _{IN}	Supply voltage input.
B1	V _{SRC}	Recommend connecting V _{SRC} terminal to the common source connection of the external MOSFETs.
B2	GND	Ground
C1	DIS	Output Discharge terminal.
C2	V _{CT}	Mode control input terminal. When V _{CT} =Low turn the external MOSFETs on, V _{CT} =High, turn the external MOSFETs off.

- **TCK401G Operation Status Table**

2.7V ≤ V_{IN} ≤ 28 V (Ta = -40 to 85°C)

V _{CT}	V _{GATE}	Discharge Q1	comment
High	ON (V _{IN} + V _{GS})	OFF	Driver ON mode
Open	OFF	ON	Driver OFF mode
Low			

- **TCK402G Operation Status Table**

2.7V ≤ V_{IN} ≤ 28 V (Ta = -40 to 85°C)

V _{CT}	V _{GATE}	Discharge Q1	comment
Low	ON (V _{IN} + V _{GS})	OFF	Driver ON mode
Open			
High	OFF	ON	Driver OFF mode

DC Characteristics (Ta = -40 to 85°C)

Characteristics	Symbol	Test Condition	Ta = 25°C			Ta = -40 to 85°C (Note 2)		Unit	
			Min.	Typ.	Max.	Min.	Max.		
Input quiescent current (ON state)	IQ(ON)	TCK401G	VCT: High, VIN = 5.0 V	—	121	—	—	222	μA
			VCT: High, VIN = 9.0 V	—	144	—	—	283	μA
			VCT: High, VIN = 12 V	—	159	—	—	294	μA
			VCT: High, VIN = 20 V	—	198	—	—	376	μA
		TCK402G	VCT: Low, VIN = 5.0 V	—	121	—	—	222	μA
			VCT: Low, VIN = 9.0 V	—	144	—	—	283	μA
			VCT: Low, VIN = 12 V	—	159	—	—	294	μA
			VCT: Low, VIN = 20 V	—	198	—	—	376	μA
Standby current (OFF state)	IQ(OFF)	TCK401G	VCT: Low, VIN = 5.0 V	—	3.0	—	—	4.8	μA
			VCT: Low, VIN = 9.0 V	—	5.9	—	—	8.2	μA
			VCT: Low, VIN = 12 V	—	8.0	—	—	11.2	μA
			VCT: Low, VIN = 20 V	—	13.8	—	—	19.2	μA
		TCK402G	VCT: High, VIN = 5.0 V	—	3.0	—	—	4.8	μA
			VCT: High, VIN = 9.0 V	—	5.9	—	—	8.2	μA
			VCT: High, VIN = 12 V	—	8.0	—	—	11.2	μA
			VCT: High, VIN = 20 V	—	13.8	—	—	19.2	μA
GATE Drive voltage(VGATE-VIN)	VGS	VIN = 3 V	—	4.0	—	2.8	5.1	V	
		VIN = 5 V	—	6.5	—	5.1	7.9	V	
		VIN = 9.0 V	—	6.5	—	5.1	7.9	V	
		12 V ≤ VIN ≤ 28 V	—	8.5	—	6.9	10.0	V	
Output current	IGATE(ON)	VIN = 5 V	—	38	—	—	—	μA	
DIS resistance	RDIS	—	—	21	—	—	—	kΩ	
Control pull down resistance	RCT	VCT= 5 V	—	600	—	—	—	kΩ	

Note 2: This parameter is warranted by design.

- AC Characteristics ($T_a = 25^\circ\text{C}$, $V_{IN} = 5\text{ V}$, $C_{GATE} = 2000\text{ pF}$)**

Characteristics	Symbol	Test Condition (Figure 1,2)	Min.	Typ.	Max.	Unit
VGATE ON time	t_{ON}	Initial startup time of V_{GATE} (Note 3) voltage from 0 V to $V_{IN} + 1\text{ V}$	—	0.58	0.8	ms
VGATE OFF time	t_{OFF}	$V_{GATE} = 0.5\text{ V}$	—	16.6	—	μs
VGATE rise time	t_r	V_{GATE} rising from $V_{IN} + 1\text{ V}$ to $V_{IN} + 3\text{ V}$	—	0.2	—	ms
VGATE fall time	t_f	V_{GATE} falling from $V_{IN} + 3\text{ V}$ to $V_{IN} + 1\text{ V}$	—	1.5	—	μs

Note 3: This parameter is warranted by design.

- AC Characteristics ($T_a = 25^\circ\text{C}$, $V_{IN} = 9\text{ V}$, $C_{GATE} = 2000\text{ pF}$)**

Characteristics	Symbol	Test Condition (Figure 1,2)	Min.	Typ.	Max.	Unit
VGATE ON time	t_{ON}	Initial startup time of V_{GATE} (Note 4) voltage from 0 V to $V_{IN} + 1\text{ V}$	—	0.78	1.0	ms
VGATE OFF time	t_{OFF}	$V_{GATE} = 0.5\text{ V}$	—	19.7	—	μs
VGATE rise time	t_r	V_{GATE} rising from $V_{IN} + 1\text{ V}$ to $V_{IN} + 4\text{ V}$	—	0.35	—	ms
VGATE fall time	t_f	V_{GATE} falling from $V_{IN} + 4\text{ V}$ to $V_{IN} + 1\text{ V}$	—	1.6	—	μs

Note 4: This parameter is warranted by design.

- AC Characteristics ($T_a = 25^\circ\text{C}$, $V_{IN} = 12\text{ V}$, $C_{GATE} = 2000\text{ pF}$)**

Characteristics	Symbol	Test Condition (Figure 1,2)	Min.	Typ.	Max.	Unit
VGATE ON time	t_{ON}	Initial startup time of V_{GATE} (Note 5) voltage from 0 V to $V_{IN} + 1\text{ V}$	—	0.92	1.2	ms
VGATE OFF time	t_{OFF}	$V_{GATE} = 0.5\text{ V}$	—	21.3	—	μs
VGATE rise time	t_r	V_{GATE} rising from $V_{IN} + 1\text{ V}$ to $V_{IN} + 5\text{ V}$	—	0.6	—	ms
VGATE fall time	t_f	V_{GATE} falling from $V_{IN} + 5\text{ V}$ to $V_{IN} + 1\text{ V}$	—	1.7	—	μs

Note 5: This parameter is warranted by design.

Timing chart

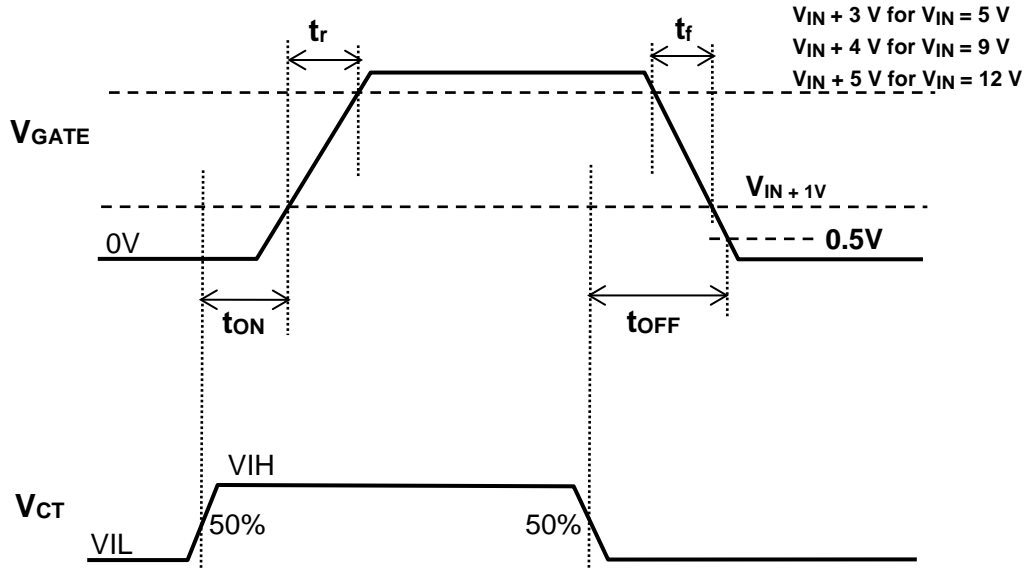

Fig.1 Active High (TCK401G)

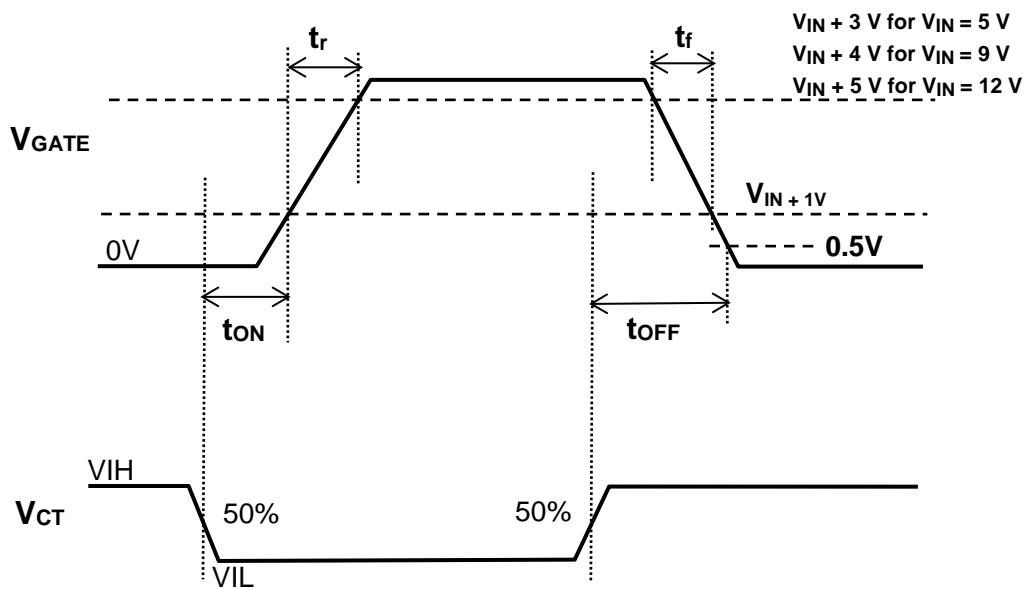
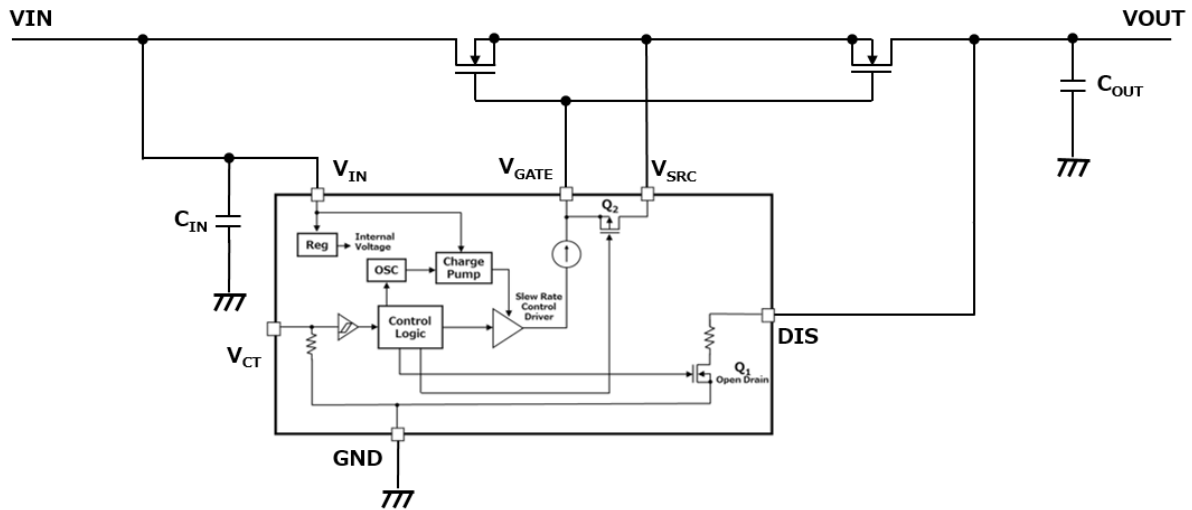

Fig.2 Active Low (TCK402G)

- Application Note
 - Application circuit example



1) Input and Output capacitor

An input capacitor (C_{IN}) and an output capacitor (C_{OUT}) are recommended for the stable operation of TCK401G and TCK402G. And it is effective to reduce voltage overshoot or undershoot due to sharp changes in output current and also for improved stability of the power supply. When used, place C_{IN} and C_{OUT} more than $1.0\mu F$ as close to TCK40xG to improve stability of the power supply.

2) V_{CT} pin

V_{CT} pin for TCK401G and TCK402G is operated by the control voltage and has Schmitt trigger. V_{CT} pin has a tolerant function such that it can be used even if the control voltage is higher than the input voltage.

3) V_{SRC} Pin

For Dual MOSFET Driver, V_{SRC} works to short between V_{GATE} and MOSFET source when Driver IC turn off. If there are enough margins of V_{GS} of MOSFET, V_{SRC} terminal Open state is no problem.

For Single MOSFET Driver, if there is enough margin of V_{GS} of MOSFET, V_{SRC} pin Open state is no problem. If there are not enough margins, we recommend connecting V_{SRC} and V_{OUT} . If connect V_{SRC} and V_{OUT} , t_{OFF} time become longer because of C_{OUT} . Therefore, please consider enough margins for MOSFET selection.

4) DIS Pin

If discharge function is needed when Driver IC turns off, please connect DIS Pin to V_{OUT} . If no need, DIS Pin Open state is no problem.

5) Over Voltage Protection off time (t_{OVP})

Over Voltage (V_{IN} is over $V_{IN_opr\ max}$) Protection off time (t_{OVP}) is similar to V_{GATE} OFF time (t_{OFF}).

Timing chart

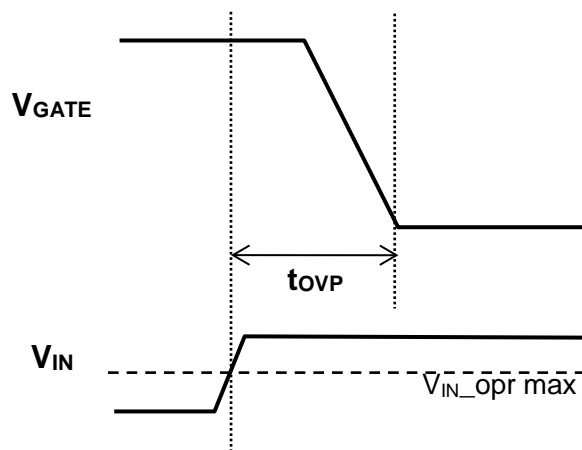
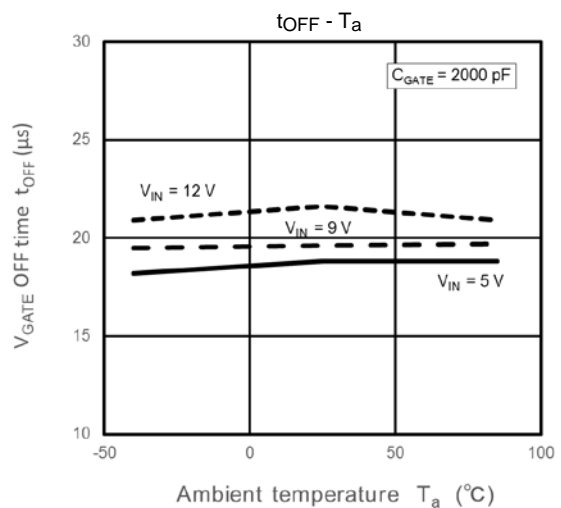
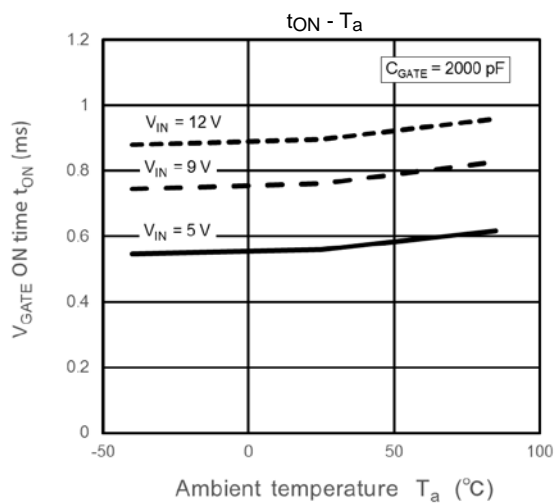
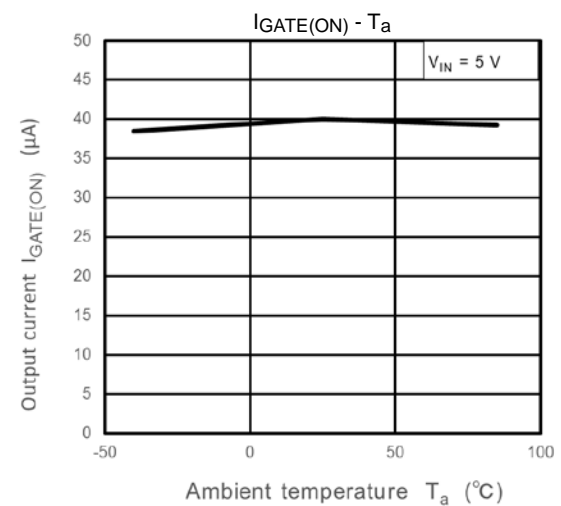
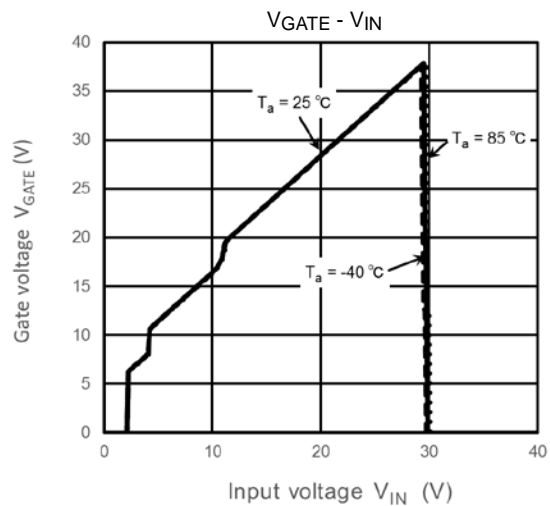
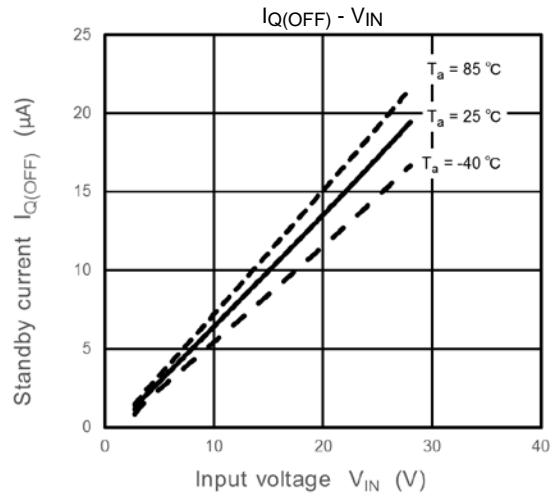
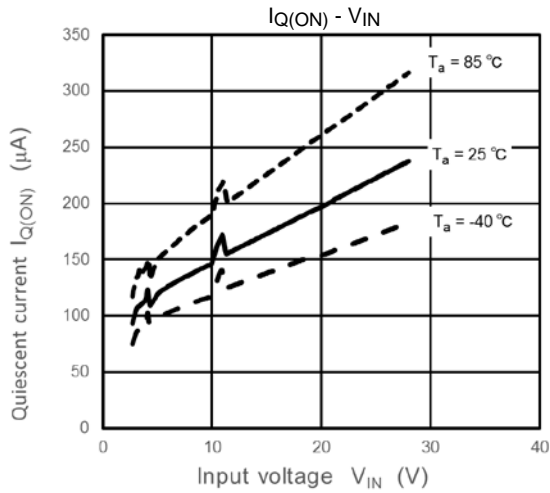
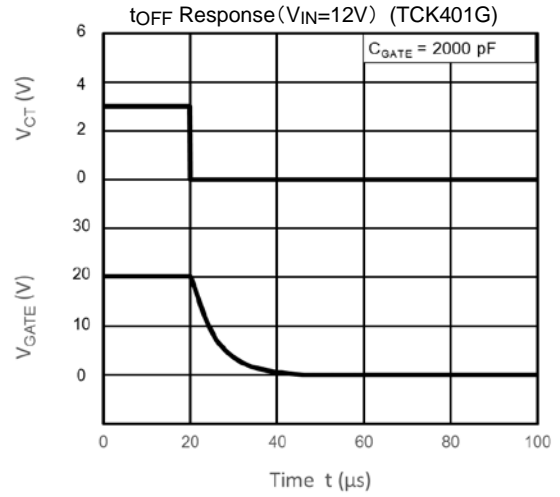
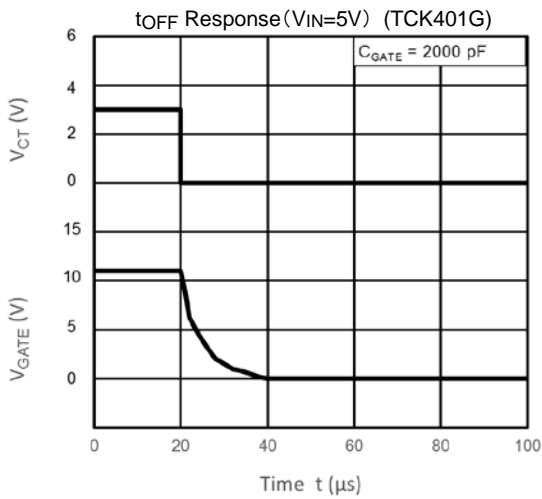
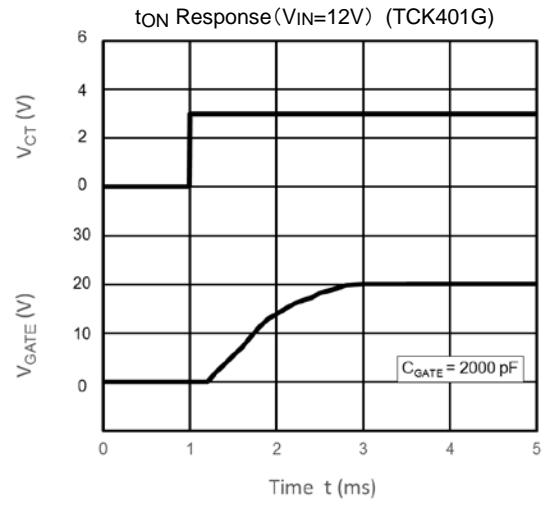
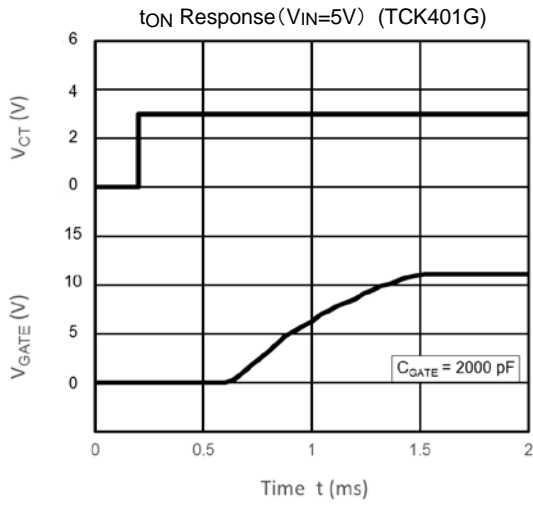

Fig.3 t_{OVP}

Representative Typical Characteristics





Note: The above characteristics curves are presented for reference only and not guaranteed by production test, unless otherwise noted.

- Package dimension

Unit: mm

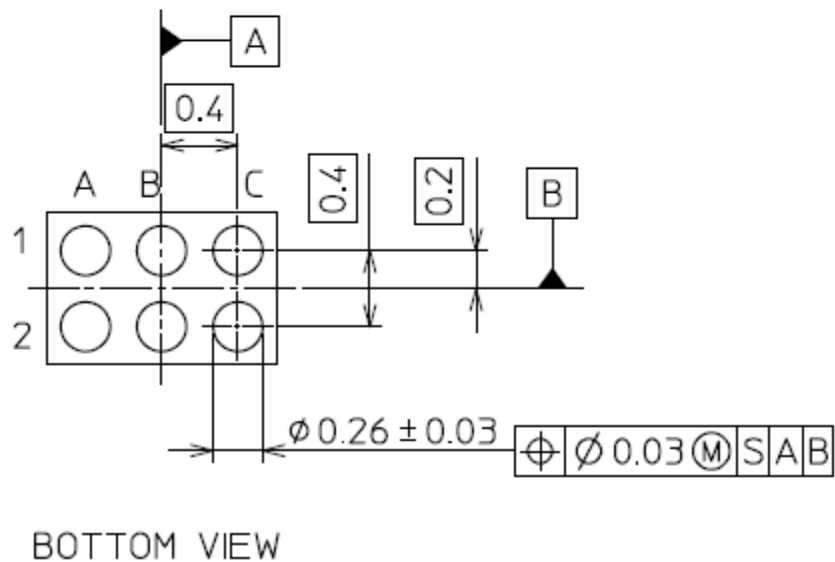
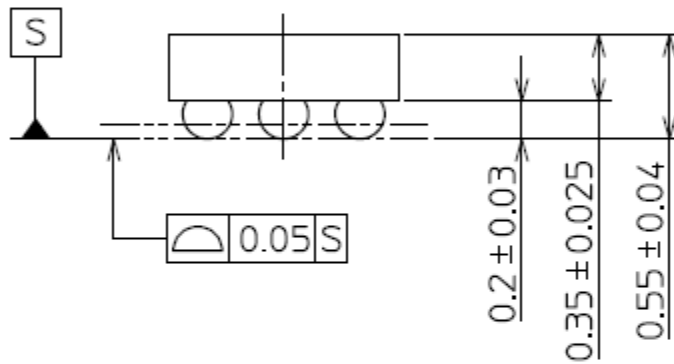

Weight: 1 mg (typ.)

Land pattern dimensions (for reference only)

Unit: mm

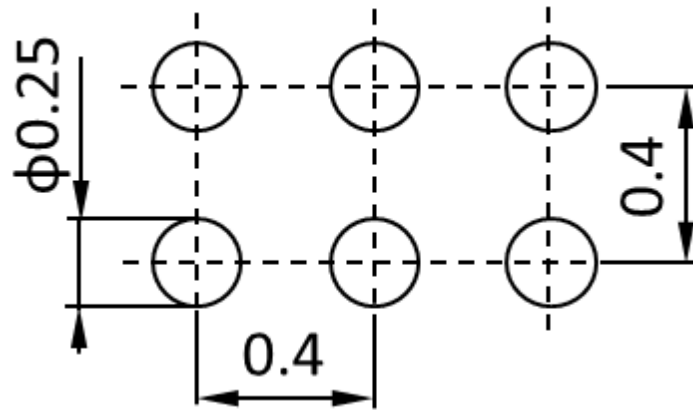

RESTRICTIONS ON PRODUCT USE

Toshiba Corporation and its subsidiaries and affiliates are collectively referred to as "TOSHIBA". Hardware, software and systems described in this document are collectively referred to as "Product".

- TOSHIBA reserves the right to make changes to the information in this document and related Product without notice.
- This document and any information herein may not be reproduced without prior written permission from TOSHIBA. Even with TOSHIBA's written permission, reproduction is permissible only if reproduction is without alteration/omission.
- Though TOSHIBA works continually to improve Product's quality and reliability, Product can malfunction or fail. Customers are responsible for complying with safety standards and for providing adequate designs and safeguards for their hardware, software and systems which minimize risk and avoid situations in which a malfunction or failure of Product could cause loss of human life, bodily injury or damage to property, including data loss or corruption. Before customers use the Product, create designs including the Product, or incorporate the Product into their own applications, customers must also refer to and comply with (a) the latest versions of all relevant TOSHIBA information, including without limitation, this document, the specifications, the data sheets and application notes for Product and the precautions and conditions set forth in the "TOSHIBA Semiconductor Reliability Handbook" and (b) the instructions for the application with which the Product will be used with or for. Customers are solely responsible for all aspects of their own product design or applications, including but not limited to (a) determining the appropriateness of the use of this Product in such design or applications; (b) evaluating and determining the applicability of any information contained in this document, or in charts, diagrams, programs, algorithms, sample application circuits, or any other referenced documents; and (c) validating all operating parameters for such designs and applications. **TOSHIBA ASSUMES NO LIABILITY FOR CUSTOMERS' PRODUCT DESIGN OR APPLICATIONS.**
- **PRODUCT IS NEITHER INTENDED NOR WARRANTED FOR USE IN EQUIPMENTS OR SYSTEMS THAT REQUIRE EXTRAORDINARILY HIGH LEVELS OF QUALITY AND/OR RELIABILITY, AND/OR A MALFUNCTION OR FAILURE OF WHICH MAY CAUSE LOSS OF HUMAN LIFE, BODILY INJURY, SERIOUS PROPERTY DAMAGE AND/OR SERIOUS PUBLIC IMPACT ("UNINTENDED USE").** Except for specific applications as expressly stated in this document, Unintended Use includes, without limitation, equipment used in nuclear facilities, equipment used in the aerospace industry, Class 3 medical devices, equipment used for automobiles, and military vehicles and munitions. **IF YOU USE PRODUCT FOR UNINTENDED USE, TOSHIBA ASSUMES NO LIABILITY FOR PRODUCT.** For details, please contact your TOSHIBA sales representative or contact us via our website.
- Do not disassemble, analyze, reverse-engineer, alter, modify, translate or copy Product, whether in whole or in part.
- Product shall not be used for or incorporated into any products or systems whose manufacture, use, or sale is prohibited under any applicable laws or regulations.
- The information contained herein is presented only as guidance for Product use. No responsibility is assumed by TOSHIBA for any infringement of patents or any other intellectual property rights of third parties that may result from the use of Product. No license to any intellectual property right is granted by this document, whether express or implied, by estoppel or otherwise.
- **ABSENT A WRITTEN SIGNED AGREEMENT, EXCEPT AS PROVIDED IN THE RELEVANT TERMS AND CONDITIONS OF SALE FOR PRODUCT, AND TO THE MAXIMUM EXTENT ALLOWABLE BY LAW, TOSHIBA (1) ASSUMES NO LIABILITY WHATSOEVER, INCLUDING WITHOUT LIMITATION, INDIRECT, CONSEQUENTIAL, SPECIAL, OR INCIDENTAL DAMAGES OR LOSS, INCLUDING WITHOUT LIMITATION, LOSS OF PROFITS, LOSS OF OPPORTUNITIES, BUSINESS INTERRUPTION AND LOSS OF DATA, AND (2) DISCLAIMS ANY AND ALL EXPRESS OR IMPLIED WARRANTIES AND CONDITIONS RELATED TO SALE, USE OF PRODUCT, OR INFORMATION, INCLUDING WARRANTIES OR CONDITIONS OF MERCHANTABILITY, FITNESS FOR A PARTICULAR PURPOSE, ACCURACY OF INFORMATION, OR NONINFRINGEMENT.**
- Do not use or otherwise make available Product or related software or technology for any military purposes, including without limitation, for the design, development, use, stockpiling or manufacturing of nuclear, chemical, or biological weapons or missile technology products (mass destruction weapons). Product and related software and technology may be controlled under the applicable export laws and regulations including, without limitation, the Japanese Foreign Exchange and Foreign Trade Law and the U.S. Export Administration Regulations. Export and re-export of Product or related software or technology are strictly prohibited except in compliance with all applicable export laws and regulations.
- Please contact your TOSHIBA sales representative for details as to environmental matters such as the RoHS compatibility of Product. Please use Product in compliance with all applicable laws and regulations that regulate the inclusion or use of controlled substances, including without limitation, the EU RoHS Directive. **TOSHIBA ASSUMES NO LIABILITY FOR DAMAGES OR LOSSES OCCURRING AS A RESULT OF NONCOMPLIANCE WITH APPLICABLE LAWS AND REGULATIONS.**