

TB67H420FTG

Application Note

Summary

The TB67H420FTG is a single-channel H-SW motor driver with sense resistor less PWM current control. It can control internal H-bridges independently, achieving control of two brushed motors or a single stepping motor with dual H-bridge drive mode. Fabricated with BiCD process, the TB67H420FTG is rated 50 V and maximum current 9.0 A (Single Mode).

1. Power supply voltage

1.1. Power supply voltage and operation range

In using the TB67H420FTG, the voltage should be applied to pins of VM (VMA/VMB) and VREF (VREFA/VREFB).

Built-in VCC regulator for internal logic power supply enables the IC to be operated with a single power supply. Applying an external voltage is unnecessary. The maximum rating of the motor supply voltage is 50 V. Its operation voltage range is 10 V to 47 V. The maximum rating of the setting voltage for PWM threshold (VREF) is 5 V. Its operation range is 0 V to 3.6 V.

VREF can be configured by dividing the voltage of VCC regulator. However, if the current exceeds the capability of the VCC regulator, the output voltage may not be kept. Therefore, when VREF is applied by dividing VCC, the voltage-dividing resistance (combined resistance of VCC and GND) should be in the range of 10 kΩ to 100 kΩ.

Table 1-1 Operation ranges of power supply voltage (Ta=-20 °C to 85 °C)

Item	Symbol	Absolute maximum ratings	Operation range	Unit	Remarks
Motor power supply voltage	VM	50	10 to 47	V	
Setting voltage for PWM threshold	VREF	5.0	0 to 3.6	V	
Voltage for internal logic power supply (Note)	VCC	6.0	4.75 to 5.25	V	Supplied by internal regulator

Note: Ta=25 °C, VM=24 V, and ICC=5 mA

1.2. Power supply sequence

There are no special procedures of applying a power supply and shutdown because TB67H420FTG can operate with a single power supply by the VCC regulator. Moreover, built-in power on reset function (POR) avoids malfunction, which occurs at the POR detection threshold or less. While POR is activated, the internal logic is initialized. POR detection threshold is as follows; POR release voltage (VMPOR(H)) in startup is 7.5 V±1.0 V, POR detection voltage (VMPOR(L)) in shutdown is 7.0 V±1.0 V, and the hysteresis is 0.5 V (typ.).

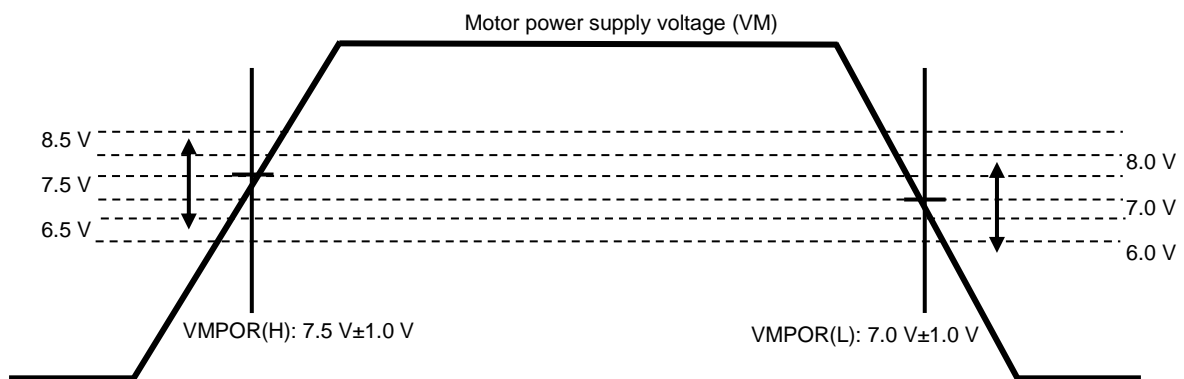

Figure 1.1 Power supply sequence and POR detection threshold

2. Output current

Motor usage current should be 9 A (Single Mode, Peak) or less in considering the heat generation. The actual-usage maximum current is limited depending on the usage conditions (the ambient temperature, the wiring pattern of the board, the radiation path, the exciting design, etc.). Therefore, configure the most appropriate current value after calculating the heat and evaluating the board under the operating environment.

3. Control input

When the control signal is input without motor power supply voltage, the electromotive force is not generated. It is recommended to set the control signal low level while VM is not supplied. Configure the control signal from low to high level after VM and VREF reach the operation voltage range.

4. PWM control

4.1. Setting PWM threshold

TB67H420FTG can configure the constant current PWM threshold only by the applied voltage to the VREF pin. External current detection resistor is not required.

The constant current value (I_{out}) of TB67H420FTG can be approximated from below formula.

$$I_{out} (A) = VREF (V) \times \text{Current decay ratio: } (VREFgain)$$

Single H-bridge drive mode (HBMODE=High): VREFgain = 2.25 (typ.)

Dual H-bridge drive mode (HBMODE=Low): VREFgain = 1.125 (typ.)

Then, when VREF of 2 V is input in single H-bridge mode (HBMODE =High), setting current is as follows;

$$I_{out} = 2(V) \times 2.25 = 4.5(A) \text{ (typ.)}$$

4.2. Setting internal oscillation frequency (fOSCM) and constant current PWM (chopping) frequency (fchop)

TB67H420FTG can set the internal oscillation frequency (fOSCM) and the PWM (chopping) frequency (fchop) with the constant numbers of the external components (resistor and capacitor), which are connected to OSCM pin.

The internal oscillation frequency can be set by connecting the resistor (ROSC) between VCC and OSCM pin, and connecting the capacitor (COSC) between OSCM pin and GND. Please set it by changing the ROSC value, while fixing COSC to 270 pF.

The relation between the internal oscillation frequency (fOSCM) and the external resistance (ROSC) is as follows (COSC = 270 pF);

$$f_{OSCM} \text{ (MHz)} = 4.0 \times ROSC \text{ (k}\Omega\text{)}^{(-0.8)}$$

Refer to the following graph (Figure 7.2 Graph of ROSC and fOSCM (Reference data/measurement data example)) for ROSC and the measured data of the internal oscillation frequency (reference data).

The relation between the internal oscillation frequency (fOSCM) and the constant current PWM (chopping) frequency (fchop) is as follows;

$$f_{chop} \text{ (MHz)} = f_{OSCM} \text{ (MHz)} / 16$$

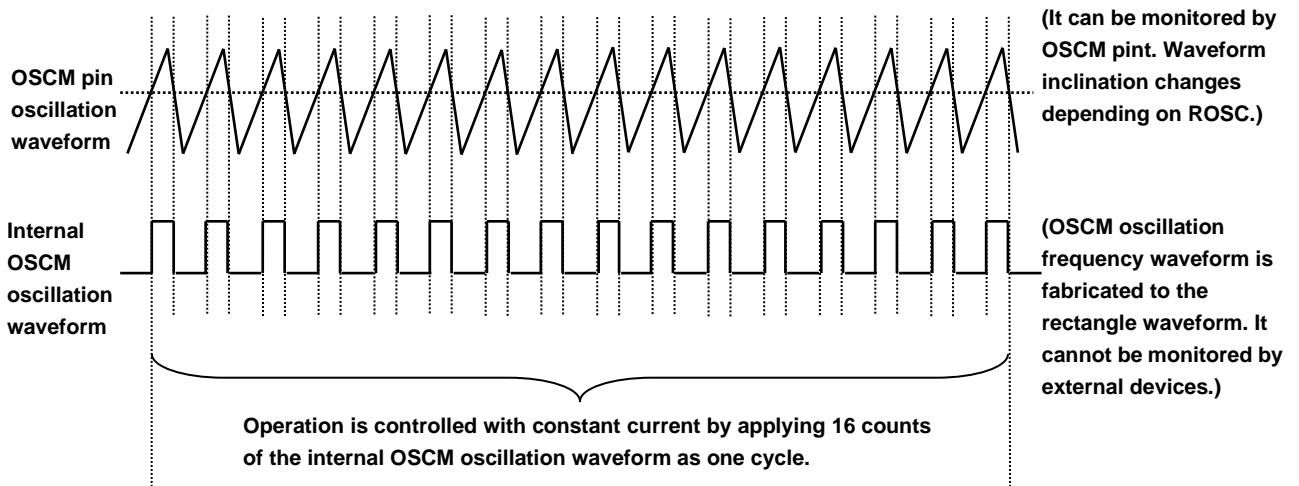

Figure 4.1 Relation of OSCM pin oscillation waveform and internal OSCM oscillation waveform

Function of internal oscillation circuit: Reduction of external components

The internal oscillation circuit of TB67H420FTG has the function of reducing external components.

Motor can be controlled by using fixed frequency.

By connecting OSCM pin to GND without connecting the resistor and the capacitor, the internal oscillation circuit activates this function.

In this mode, configuration of the internal oscillation frequency (fOSCM) is about 912 kHz and of the constant current PWM (chopping) frequency (fchop) is about 57 kHz.

Note: This function is activated when judging period of 20 μs (typ.) has passed after both POR and STANDBY are released. Do not input control signals and keep the state of OSCM pin during the judging period. Moreover, do not switch OSCM operation between normal mode and external-component reduction mode during motor drive. Please drive the motor by fixing either of the modes.

4.3. Constant current waveform in changing chopping frequency

Chopping frequency (f_{chop}) is recommended to set 40 kHz to 120 kHz on the basis of 67 kHz. When the chopping frequency is increased, ripple current of the motor is decreased and the waveform quality is improved. Moreover, the heat generates because the increased chopping frequency enhances the switching loss. To improve the waveform quality, increase the chopping frequency. To reduce the heat generation, decrease the frequency.

(Example 1) When chopping frequency (f_{chop}) = 100 kHz,

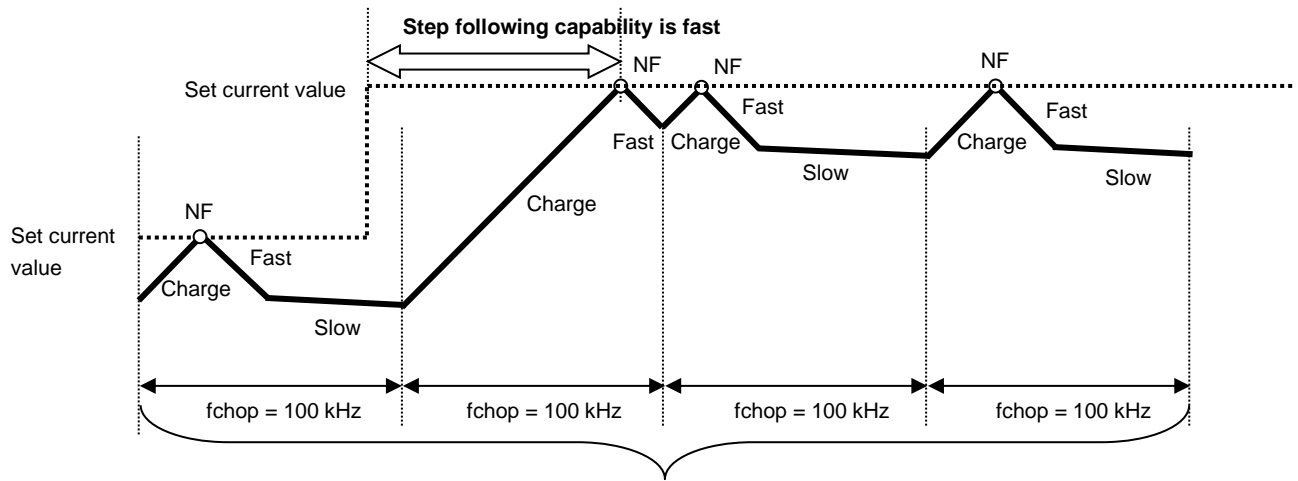

The number of chopping is large → Switching loss and heat are large

Figure 4.2 Chopping frequency (100 kHz)

(Example 2) When chopping frequency (f_{chop}) = 72 kHz,

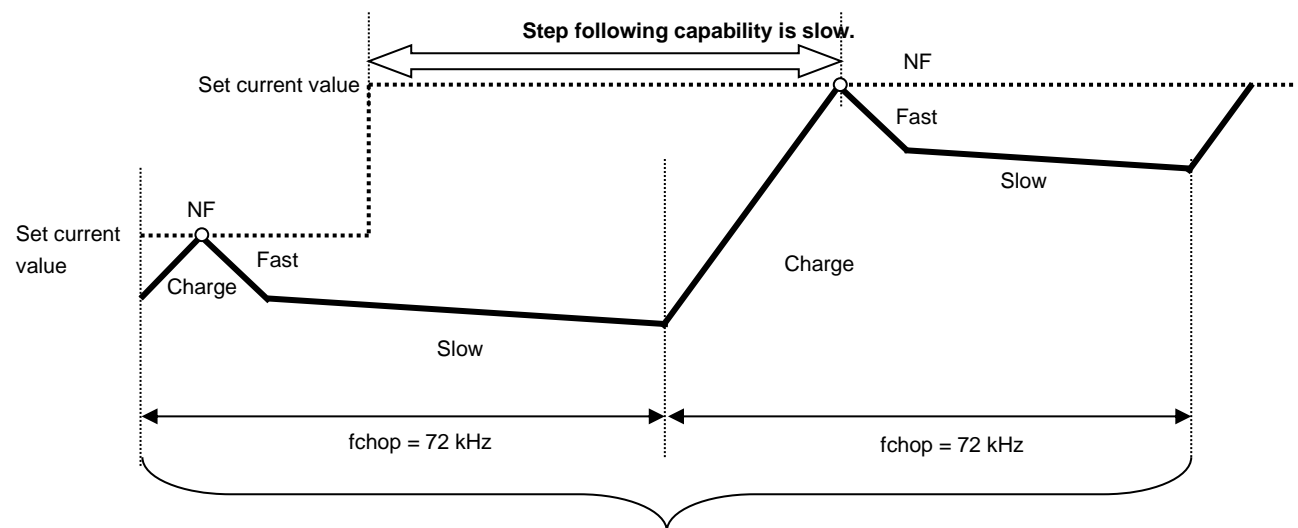

The number of chopping is small → Switching loss and heat are small

Figure 4.3 Chopping frequency (72 kHz)

5. Output switching characteristics

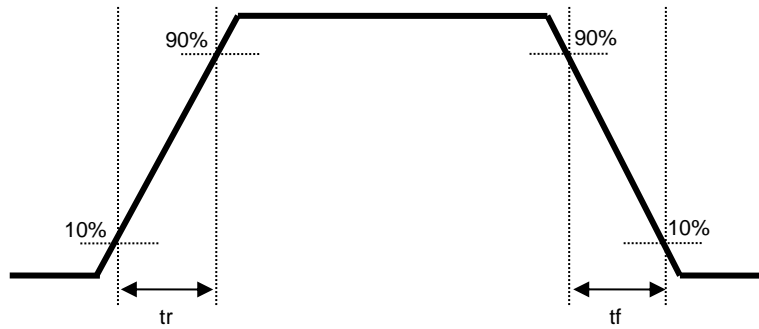

Figure 5.1 Switching characteristics

Table 5-1 Switching characteristics ($T_a = 25\text{ }^\circ\text{C}$, $V_M = 24\text{ V}$, No load)

Item	Typ.	Unit
tr	110	ns
tf	110	ns

6. Function explanation

6.1. TBLKAB (Noise filter setting pin for constant current circuit) function

TBLKAB pin prevents the constant-current detection circuit from miss detecting a rush current occurred from a varistor element.

The blanking time ((1) Digital tblank), which is based on OSCM signal, is prepared at charge start.

TBLKAB pin	Function
High	Digital tblank = $(1 / f_{OSCM}(\text{MHz})) \times 6(\text{clk})$
Low	Digital tblank = $(1 / f_{OSCM}(\text{MHz})) \times 4(\text{clk})$

Blanking time of constant current PWM control

The TB67H420FTG prepares below blanking time ((2) Analog tblank) to avoid influences of spike current occurred during motor operation and external noises.

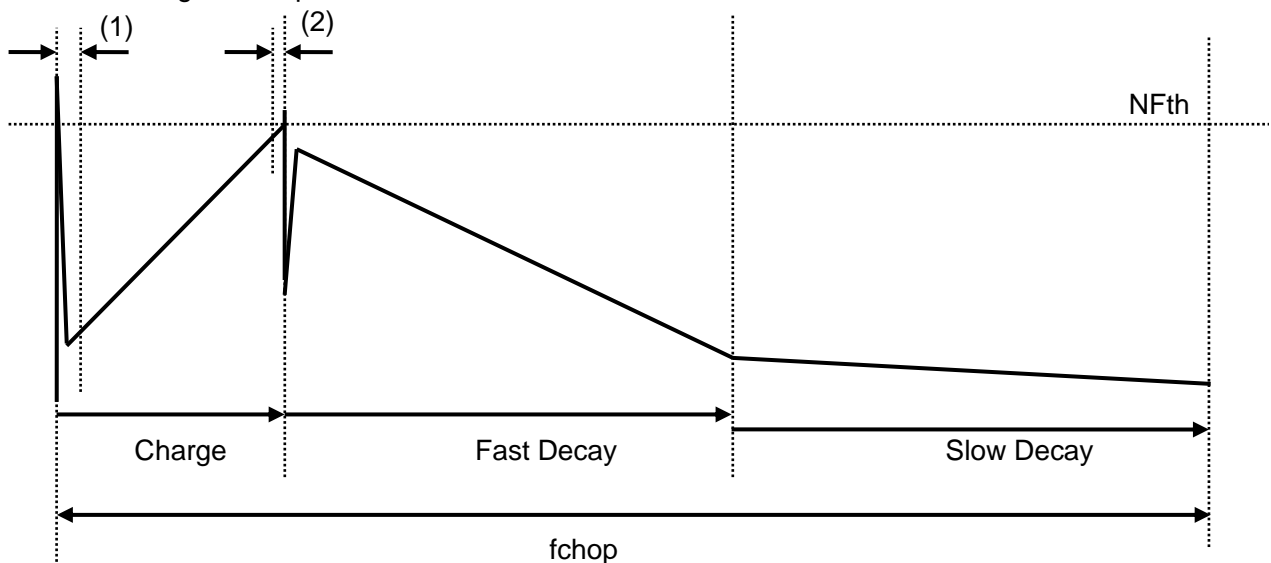

Figure 6.1 Timing of constant current PWM blanking time (Digital tblank and Analog tblank)

Note: Timing charts may be simplified for explanatory purposes.

- (1) Digital tblank (avoiding miss detection of spike current occurred in switching from Decay mode to Charge mode): Setting value of TBLKAB pin
- (2) Analog tblank (avoiding miss detection of the current generated around NFth): Fixed value of 0.35 μs (typ.). Above time width is design value for reference only, not guaranteed.

Correlation between control signals IN1, IN2 and digital tblank

The digital tblank is prepared in considering the rush current occurred in switching from Decay mode to Charge mode. The TB67H420FTG drives the motor not only by the constant current PWM control, but also by the direct PWM control, which switches IN1 and IN2 signals at the arbitrary timing. Therefore the digital tblank is set at each IN switch timing (shown with gray in the below timing chart).

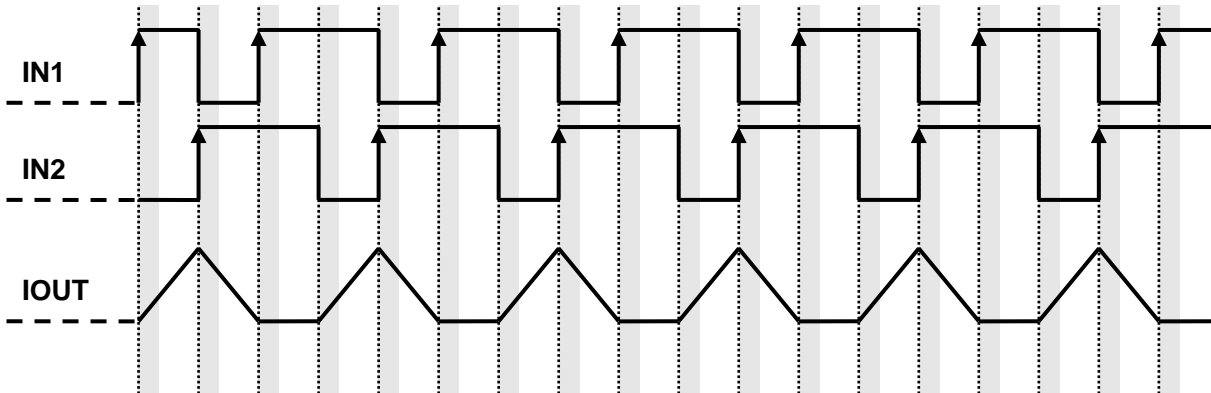

Figure 6.2 Timing of constant current PWM blanking time (Digital tblank) for IN1, IN2

Note: Timing charts may be simplified for explanatory purposes.

6.2. HBMODE (H-bridge drive mode setting pin) function

Driving mode of the motor output is set by HBMODE.

HBMODE pin	Function
High	Single H-bridge drive mode (Two H-bridges are controlled in parallel.)
Low	Dual H-bridge drive mode (Two H-bridges are controlled individually.)

Single H-bridge drive mode: By driving two H-bridges with a parallel assignment, they can operate as a single H-bridge (maximum current: 9 A, output on resistance: 0.165 Ω (upper + lower, typ.)). It is optimum for large current drive.

Dual H-bridge drive mode: Two H-bridges can be controlled independently (maximum current: 4.5 A, output on resistance: 0.33 Ω (upper + lower, typ.)). It is optimum for dual brushed motor drive.

For prevention of malfunctions generated from external noises, the bridge drive mode does not switch even if the HBMODE pin level is changed after the motor power supply voltage rises. Therefore, in case of setting the HBMODE pin to high level, connect it to the VCC, and setting to low level, connect it to the GND. Functions of control pins are different depending on the HBMODE pin level.

The internal circuits are designed to avoid EMF or leakage current when the logic signal is applied while the VM is not supplied. However, it is recommended to set the control input to low level. Configure the control signal to avoid motor operation during power-on sequence.

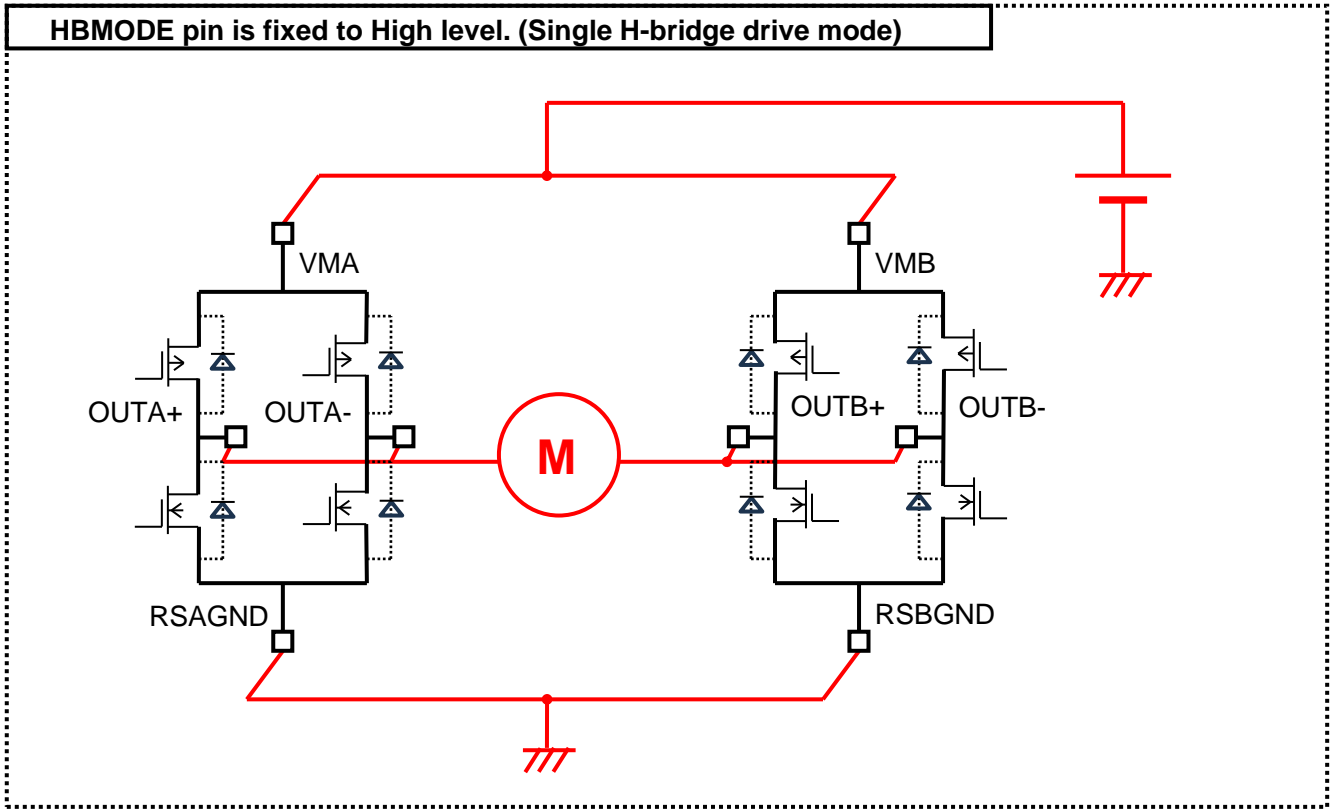

Figure 6.3 Connection example (Single H-bridge drive mode)

Note 1: The equivalent circuit diagrams may be simplified or some parts of them may be omitted for explanatory purposes.

Note 2: When using the single H-bridge drive mode, the impedance on the board should be balanced. Also, the power supply pins for H-bridges (VMA and VMB), output pins (OUTA+ and OUTA-, OUTB+ and OUTB-), and RSGND pins (RSAGND and RSBGND) should be connected to each other on the board.

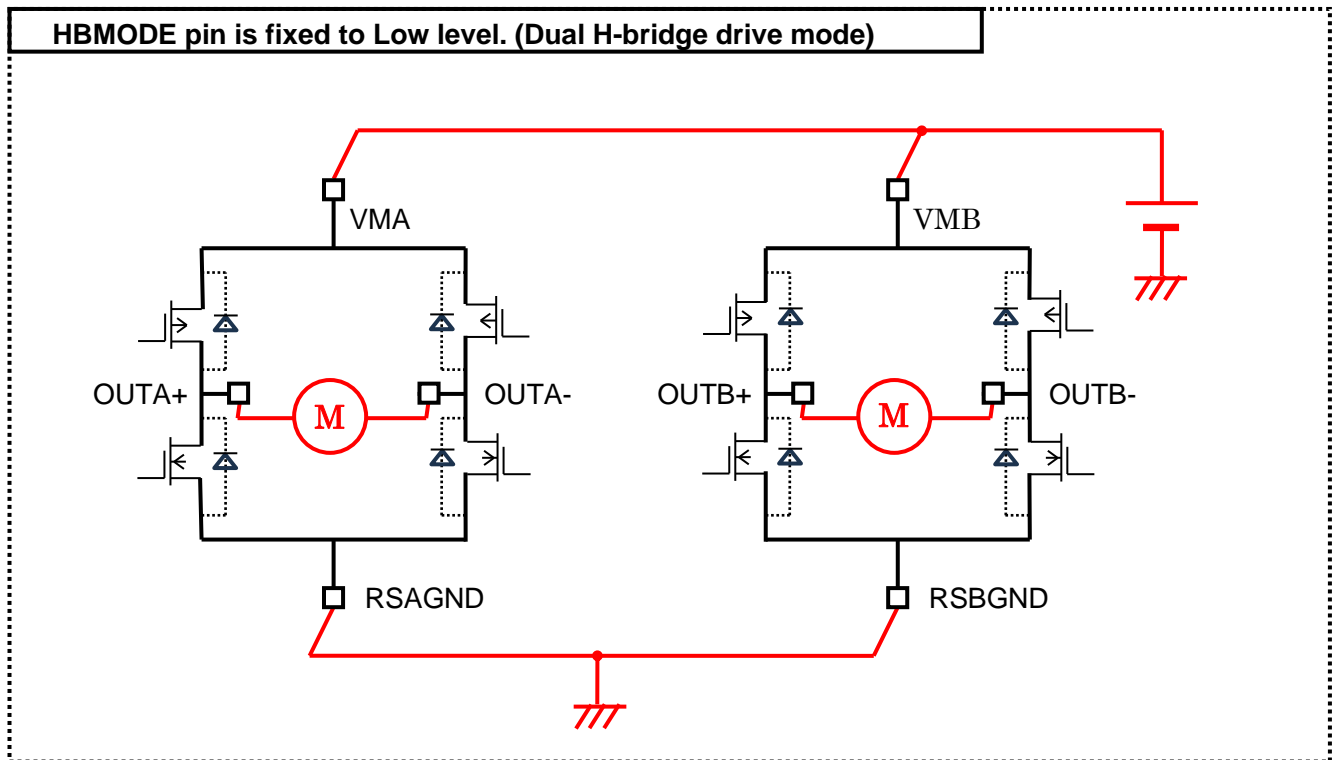

Figure 6.4 Connection example (Dual H-bridge drive mode)

Note: The equivalent circuit diagrams may be simplified or some parts of them may be omitted for explanatory purposes.

6.3. IN1, IN2(H-bridge control pins), and PWM(Short brake pins for H-bridge) functions

H-bridges are controlled by IN1, IN2, and PWM pins.

When HBMODE pin is set to high level, both H-bridges are controlled by INA1, INA2, and PWMA pins and the INB1, INB2, and PWMB pins become invalid (Don't care).

H-bridge function

HBMODE pin input	PWMA pin input	INA1 pin input	INA2 pin input	OUTA+ OUTB+ pins output	OUTA- OUTB- pins output	Drive mode	
High	Low	Low	Low	Hi-Z	Hi-Z	(Note)	
		High	Low	Low	Low	Short brake	
		Low	High				
		High	High				
	High	High	Low	Low	Hi-Z	Hi-Z	STOP (OFF)
			High	Low	High	Low	CW (Forward rotation)
			Low	High	Low	High	CCW (Reverse rotation)
			High	High	Low	Low	Short brake

HBMODE pin input	PWMB pin input	INB1 pin input	INB2 pin input
High	invalid	invalid	invalid

Note: The standby mode is enabled in TB67H420FTG. When performing short brake control from standby mode, the power supply current may increase due to the residual charge caused by the motor load. When starting operation from short brake, it is recommended to set from STOP mode to short brake mode.

When HBMODE pin is set to low level, H-bridge (Ach) is controlled by INA1, INA2, and PWMA pins, and H-bridge (Bch) is controlled by INB1, INB2, and PWMB pins.

H-bridge (Ach) function

HBMODE pin input	PWMA pin input	INA1 pin input	INA2 pin input	OUTA+ pin output	OUTA- pin output	Drive mode
Low	Low	Low	Low	Hi-Z	Hi-Z	(Note)
		High	Low	Low	Low	Short brake
		Low	High			
		High	High			
	High	Low	Low	Hi-Z	Hi-Z	STOP (OFF)
		High	Low	High	Low	CW (Forward rotation)
		Low	High	Low	High	CCW (Reverse rotation)
		High	High	Low	Low	Short brake

H-bridge (Bch) function

HBMODE pin input	PWMB pin input	INB1 pin input	INB2 pin input	OUTB+ pin output	OUTB- pin output	Operation mode
Low	Low	Low	Low	Hi-Z	Hi-Z	(Note)
		High	Low	Low	Low	Short brake
		Low	High			
		High	High			
	High	Low	Low	Hi-Z	Hi-Z	STOP (OFF)
		High	Low	High	Low	CW (Forward rotation)
		Low	High	Low	High	CCW (Reverse rotation)
		High	High	Low	Low	Short brake

Note: Only when the all input pins are set to low level, the standby mode is enabled in TB67H420FTG. When performing short brake control from standby mode, the power supply current may increase due to the residual charge caused by the motor load. When starting operation from short brake, it is recommended to set from STOP mode to short brake mode.

6.4. LO1, LO2 (Error flag output pins) function

The LO1 and LO2 pins output signals when the error state is detected in TB67H420FTG. Both pins are open drain outputs, therefore must be pulled up to VCC with a pull up resistor in the range of 10 kΩ to 100 kΩ.

Once the error detection is released by reasserting the VM or using the standby mode, LO1 and LO2 pins return to the normal status. Leave the pins open when this function is not used.

LO1 pin	LO2 pin	Function
VCC(Hi-Z)	VCC(Hi-Z)	Normal status (Normal operation)
VCC(Hi-Z)	Low	Detect motor load open (OPD)
Low	VCC(Hi-Z)	Detect over current (ISD)
Low	Low	Detect over thermal (TSD)

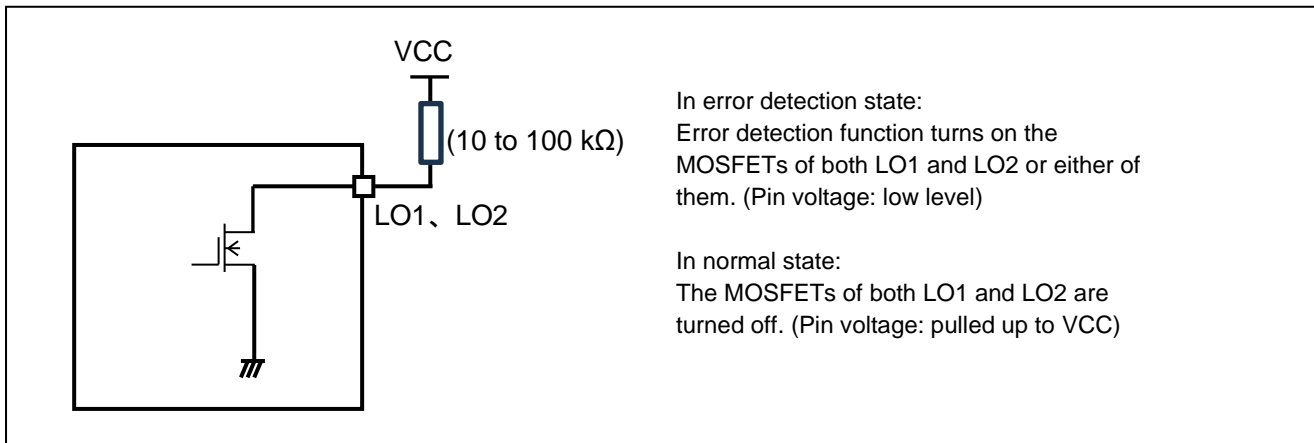

Figure 6.5 Connection example (LO1 and LO2 logic output pins)

Note: The equivalent circuit diagrams may be simplified or some parts of them may be omitted for explanatory purposes.

7. Application circuit example (Single H-bridge drive mode)

In the case of using VRFE configured by dividing the voltage of VCC regulator

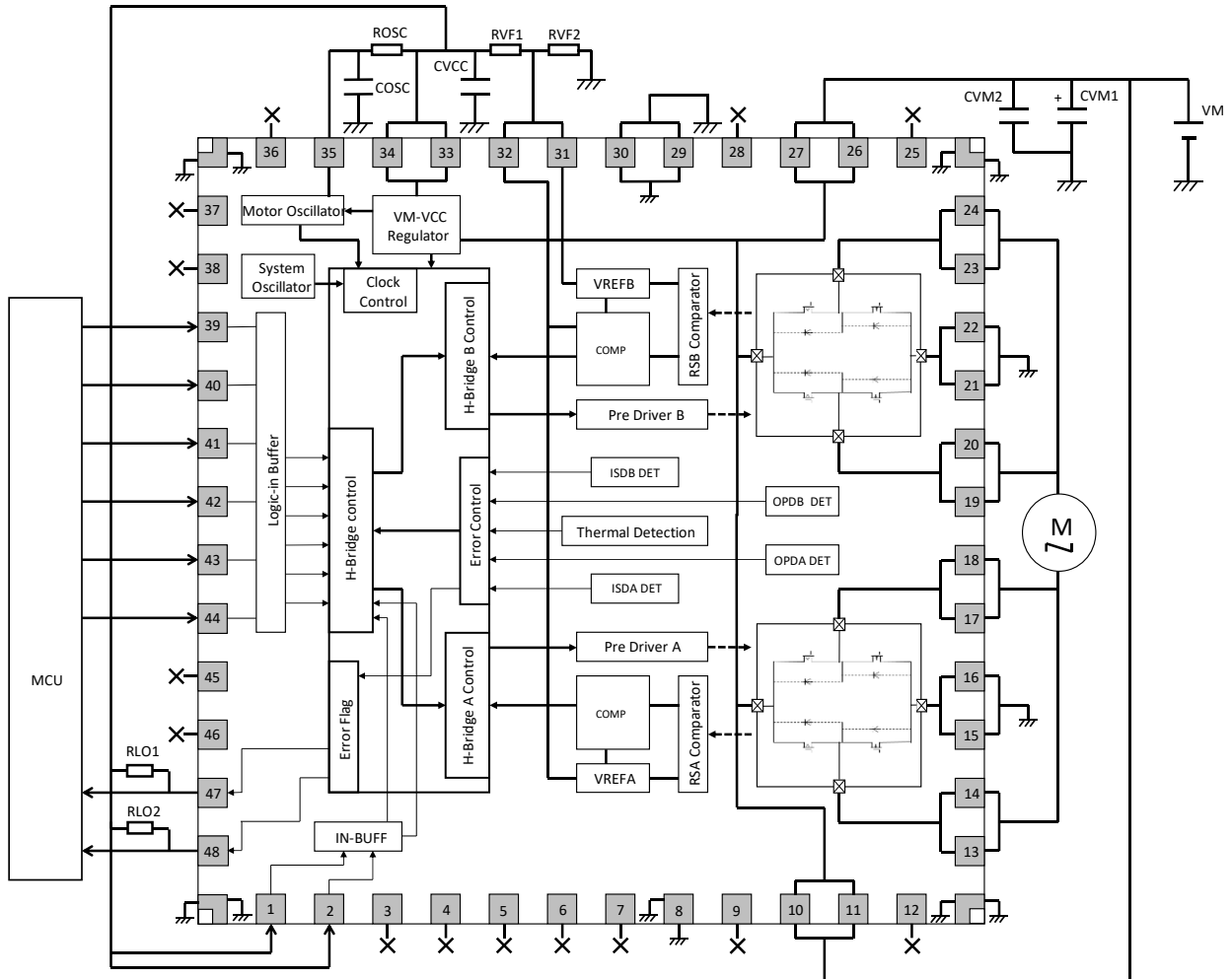

Figure 7.1 Application circuit example

Note: Above application circuit example is provided for reference purposes only, and are not guaranteed for mass production.

External component description

(1) Capacitors for power supply pins

To stabilize the power supply voltage of the TB67H420FTG and reduce the noise, connect the appropriate capacitor to each pin. It is recommended to connect the capacitors as close to the IC as possible. Especially, by connecting the ceramic capacitor near the IC, the power supply fluctuations at the high frequency range and the noise can be reduced.

Table 7-1 Recommended capacitor values for power supply pins

Item	Components	Typ. (μF)	Recommended range (μF)
Between VM pin and GND	Decoupling capacitor (CVM1)	100	22 to 100
Between VCC pin and GND	Bypass capacitor (CVCC)	0.1	0.01 to 1
(Between VREF pin and GND)	Bypass capacitor (CVF)	0.1	0.01 to 1

Note 1 : Between VREF pin and GND: Connect the capacitor in necessary depending on the usage environment.

Note 2 : It is possible to remove some capacitors for power supply pins and use other than the recommended capacitors depending on the motor load condition and the designed pattern of the board.

(2) Internal oscillation frequency

OSCM oscillation frequency can be adjusted by external capacitor (C) and resistor (R). In adjusting, it is recommended to change R, while fixing C to 270 pF. Chopping frequency can be also changed by adjusting OSCM frequency. Please refer to below table in adjusting the chopping frequency.

This IC	TB67H420FTG
Board	Evaluation board of our company
Motor power supply voltage (VM)	24 V
COSC	270 pF

Table 7-2 Relation of external resistor (ROSC) and Internal oscillation frequency (fOSCM), chopping frequency (fchop) (for reference only)

ROSC (kΩ)	fOSCM (MHz)	fchop (kHz)
1.5	2.63	164.38
1.8	2.37	148.13
2.0	2.23	139.38
2.2	2.08	130.00
2.7	1.80	112.50
3.0	1.67	104.38
3.3	1.55	96.88
3.9	1.34	83.75
4.7	1.15	71.88
5.1	1.07	66.88
5.6	0.98	61.25
6.8	0.83	51.88
8.2	0.70	43.75
10.0	0.58	36.25

Setting chopping frequency range
40 kHz to 150 kHz

← Reference value

Note: Values in above table are reference data. They are not guaranteed.

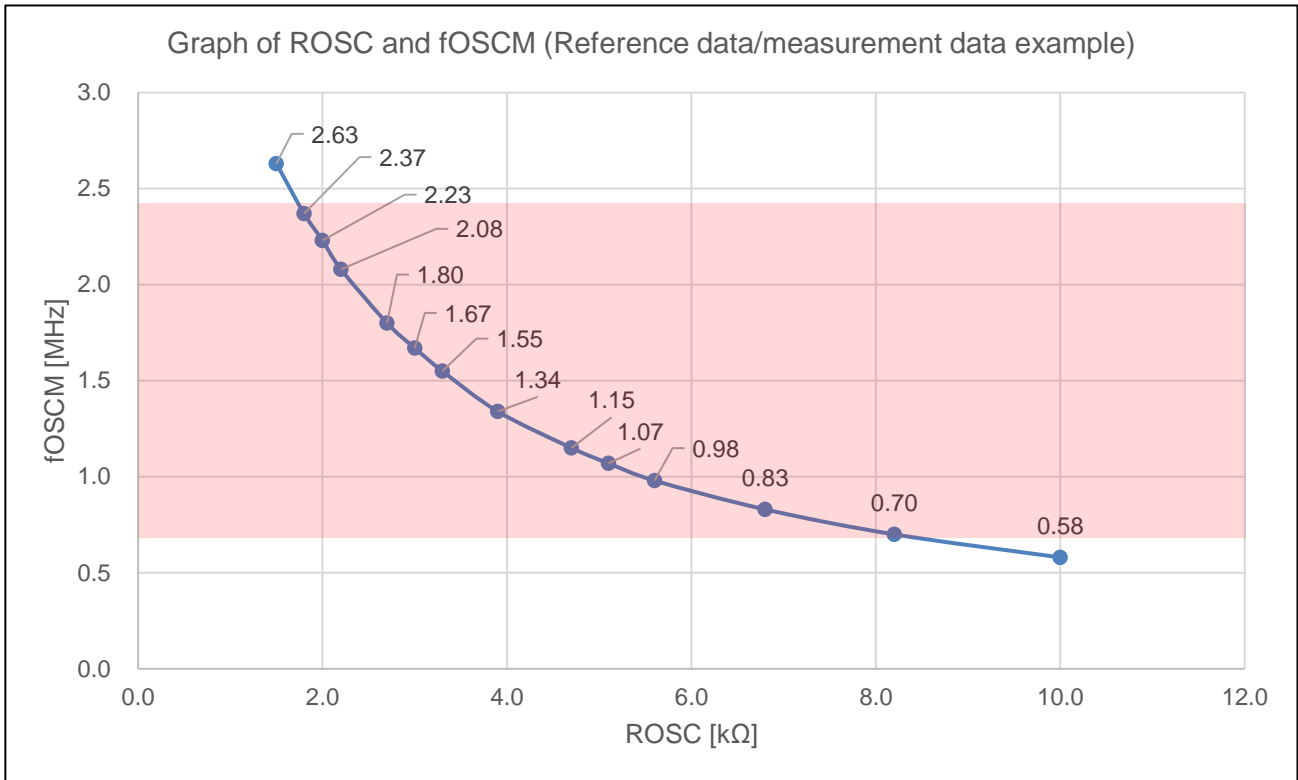

Figure 7.2 Graph of ROSC and fOSCM (Reference data/measurement data example)

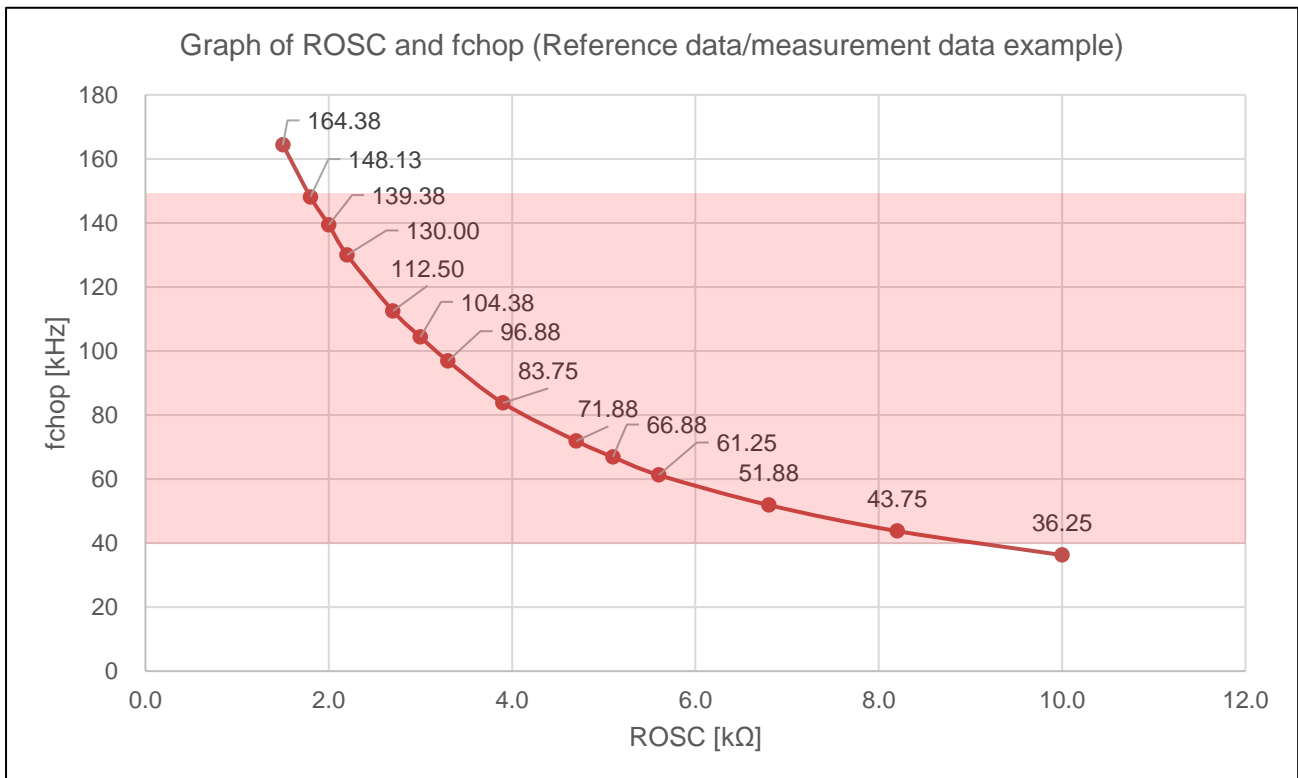

Figure 7.3 Graph of ROSC and fchop (Reference data/measurement data example)

Note: Values in the graphs are reference data. They are not guaranteed.

(3) Pull up resistors for error flag output pins

TB67H420FTG has two open-drain pins of LO1 and LO2 for error flag output pins. And when this function is not used, these pins should be left open or connected to GND.

Table 7-3 Recommended pull up resistors for error flag output pins

Item	Components	Typ. (kΩ)	Recommended range (kΩ)
Between LO1 / LO2 pins and VCC	Chip/Lead resistor	10	10 to 100

(4) Wiring pattern for power supply and GND

Since large current may flow in the pattern to VM pin, OUT+ pin, OUT- pin, and GND pin especially, design the appropriate board in order to avoid the influence of wiring impedance. It is very important for surface mounting package to radiate the heat from the heat sink back side to the GND. So, design the pattern by considering the heat design.

(5) Fuse

Use an appropriate power supply fuse for the power supply line to ensure that a large current does not continuously flow in the case of over current and/or IC failure.

The IC will fully break down when used under conditions that exceed its absolute maximum ratings, when the wiring is routed improperly or when an abnormal pulse noise occurs from the wiring or load, causing a large current to continuously flow and the breakdown can lead to smoke or ignition. To minimize the effects of the flow of a large current in the case of breakdown, appropriate settings, such as fuse capacity, fusing time and insertion circuit location, are required.

This IC incorporates over current detection circuit (ISD) that turns off the output of the IC when over current is detected in the IC. However, it does not necessarily protect ICs under all circumstances. If the over current detection circuits operate against the over current, clear the over current status immediately.

Depending on the method of use and usage conditions, such as exceeding absolute maximum ratings can cause the over current protection circuit to not operate properly or IC breakdown before operation. In addition, depending on the method of use and usage conditions, if over current continues to flow for a long time after operation, the IC may generate heat resulting in breakdown.

To avoid above IC destruction and malfunctions caused by noise, the over current detection circuit has a dead band time. So, it is concerned that the over current detection circuit may not operate depending on the output load conditions because of the dead band time. Therefore, in order to avoid continuing this over current state, use the fuse for the power supply line.

(6) Error detection function

TB67H420FTG has thermal shutdown circuit (TSD) and over current protection (ISD) as error detection functions. Description of each function is as follows;

- **Thermal shutdown circuit (TSD)**

When the junction temperature of the IC reaches the specified value, the internal detection circuit operates to turn off the output block. It has a dead band time to prevent the IC from malfunction, which is caused by switching and so on. While TSD is activated, the operation of the IC is in the standby mode. To release this function, apply the power supply again or use the standby mode. TSD works when the IC is heated abnormally. Therefore, use the IC with the appropriate environment not to operate the TSD function often.

Dead band time of thermal shutdown circuit

This IC has a system clock ($f_{OSCS} = 6.4 \text{ MHz (typ.)}$) to count up a dead band time for the error detection function. Thermal shutdown circuit can avoid a false detection by configuring the dead band time (t_{TSD}), which is counted by the system clock.

$$t_{TSD} = 5 \mu\text{s (typ.)}$$

- **Over current protection (ISD)**

When the current value exceeds the specified value in the H-bridge motor output pin, internal detection circuit operates to turn off the output block. It has a dead band time to prevent the IC from malfunction, which is caused by switching and so on. While ISD is activated, the operation of the IC is in the standby mode. To release this function, apply the power supply again or use the standby mode.

Dead band time of over current protection

This IC has a system clock ($f_{OSCS} = 6.4 \text{ MHz (typ.)}$) to count up a dead band time for the error detection function. Over current protection can avoid a false detection by configuring the dead band time (t_{ISD}), which is counted by the system clock.

$$t_{ISD} = 1.25 \mu\text{s (typ.)}$$

8. Power consumption of the IC

Power of the TB67H420FTG is consumed mainly by the transistor of the output block and by that of the internal block, which includes logic block.

- P (total) = Power consumption of the IC
- P (out) = Power consumption of the motor output block
- P (bias) = Power consumption of the internal circuit

$$P \text{ (total)} = P \text{ (out)} + P \text{ (bias)}$$

- Power consumption of the motor output block

The motor output block consumes the power (P (out)) when the motor current flows in the output MOSFET. In case of driving two brushed motors, assign '2' to the number of H-SW in the below formula.

$$P \text{ (out)} = \text{Number of H-SW} \times \text{Motor current} \times \text{Motor current} \times \text{On resistance} \quad \dots\dots\dots(1)$$

The power consumption calculated from above formula corresponds to the peak current when the motor driving current reaches the maximum value. However, the peak current does not flow continually in the actual motor. Therefore, the average motor driving current is lower than the configured current because of the current ripple in the constant PWM drive and of the current decay in switching step resolution. The power consumption above is only for reference.

(Example) When two brushed motors are driven with the motor current of 1 A,

$$P \text{ (out)} = 2 \times 1.0(\text{A}) \times 1.0(\text{A}) \times 0.33(\Omega) = 0.66(\text{W})$$

- Power consumption of the internal circuit

The power for the internal circuit including the logic block is continually consumed by applying VM voltage for the motor operation (standby release mode). This power consumption (P (bias)) is calculated from below formula.

$$P \text{ (bias)} = \text{Motor power supply voltage} \times \text{Current consumption} \quad \dots\dots\dots(2)$$

(Example) When motor power supply voltage of 24 V is applied, current consumption is 0.006 A under condition of out-open and released standby mode,

$$P \text{ (bias)} = VM \times IM3, \text{ then } 24(\text{V}) \times 0.006(\text{A}) = 0.144(\text{W})$$

From above formula, the rough value of this IC power consumption is as follows;

$$P \text{ (total)} = P \text{ (out)} + P \text{ (bias)} = 0.66(\text{W}) + 0.144(\text{W}) = 0.804(\text{W})$$

The power consumption of the standby mode, which reduces bias current of the internal circuit, can be calculated from the formula (2) by substituting IM1 (standby mode) for IM current consumption.

$$P \text{ (bias)} = VM \times IM1 = 24(\text{V}) \times 0.002(\text{A}) = 0.048(\text{W})$$

9. Power dissipation

Relation equation of the ambient temperature (T_a), the junction temperature (T_j), and the heat resistance ($R_{th(j-a)}$) between the junction temperature and the ambient temperature is as follows;

$$T_j = T_a + P \times R_{th(j-a)}$$

TB67H420FTG adopts a surface mounting package, QFN48. QFN48 package radiates the heat from the heat sink of the IC's back side. $R_{th(j-a)}$ depends on board design pattern and GND area.

(Example) If $R_{th(j-a)}$ is 25 °C/W when the IC is mounted on glass-epoxy 4-layer board, the junction temperature at ambient temperature $T_a = 25$ °C can be calculated from below formula. Conditions of the power consumption are as the same as the section 8 Power consumption of the IC.

$$T_j = 25(°C) + 0.804(W) \times 25(°C/W) = 45.1(°C)$$

(Reference) Relation of power dissipation (PD) and ambient temperature (T_a)

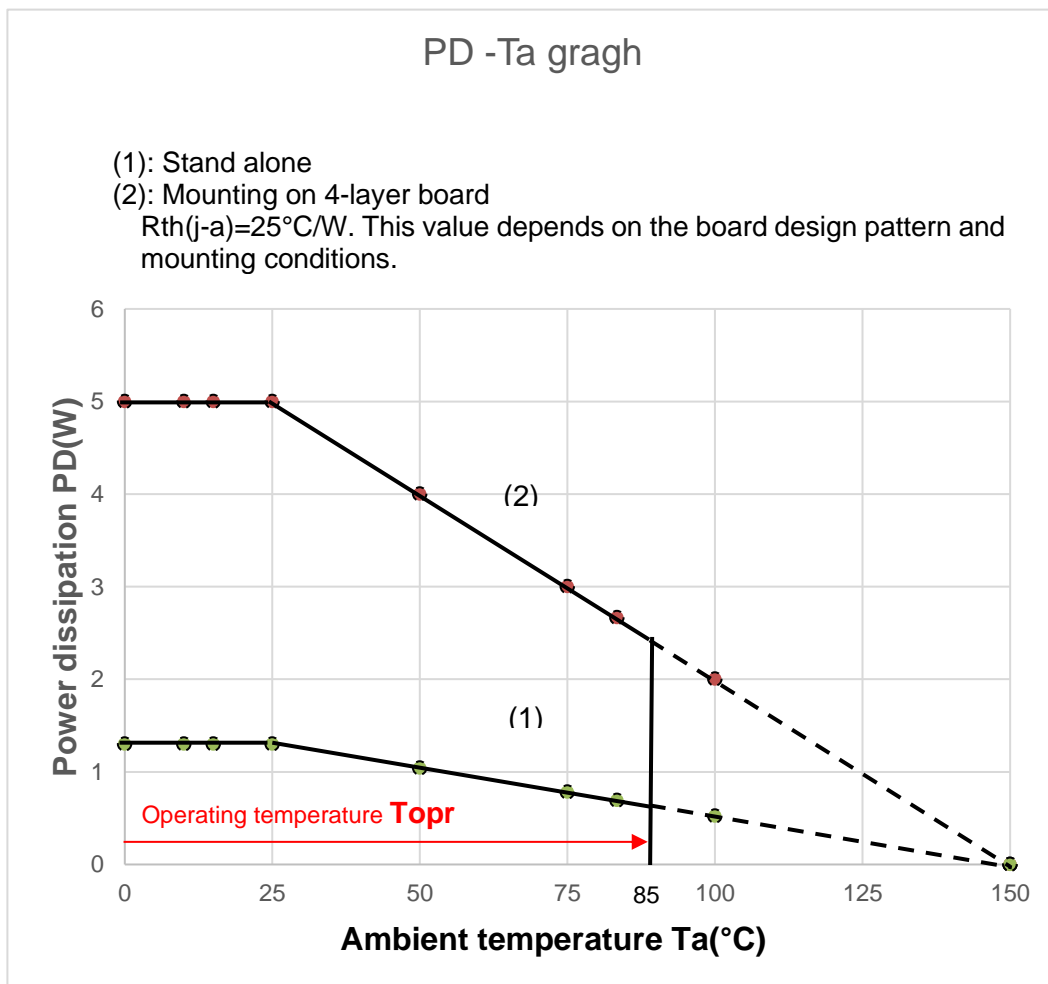

Figure 9.1 Relation of power dissipation (PD) and ambient temperature (T_a)

Note: T_a , $R_{th(j-a)}$, and P (total) depend on the usage environment, the board and the motor to use.

10. Foot pattern example

(1) QFN48 foot pattern example (unit: mm)

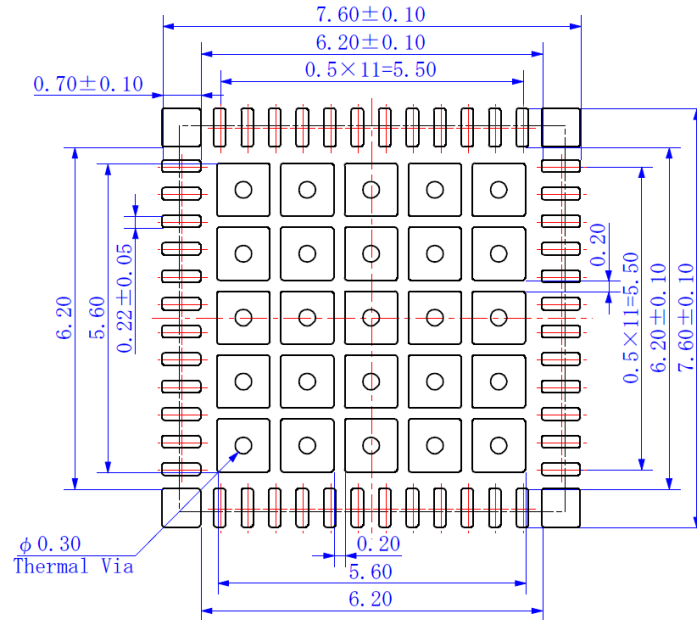

Figure 10.1 QFN48 foot pattern example

Note: The above data is for reference only and cannot be used for mass production.

In designing the size of mounting board, determine the foot pattern by considering the solder bridge, the solder connecting strength, the pattern accuracy in making board, and the mounting accuracy of the IC board.

11. Board dimensions (original board examples of our company)

11.1. Input / Output

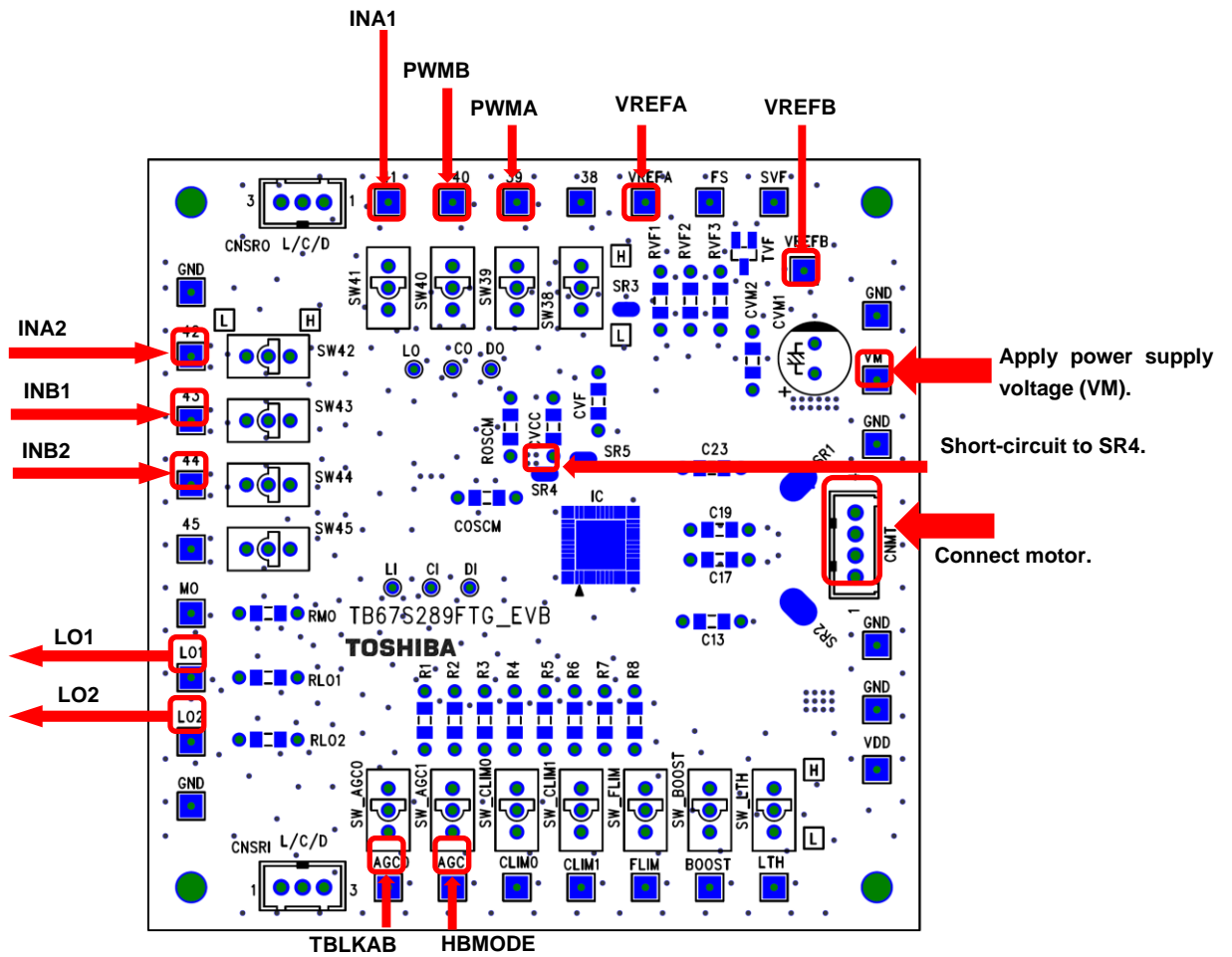

Figure 11.1 Input/Output

11.2. Main part

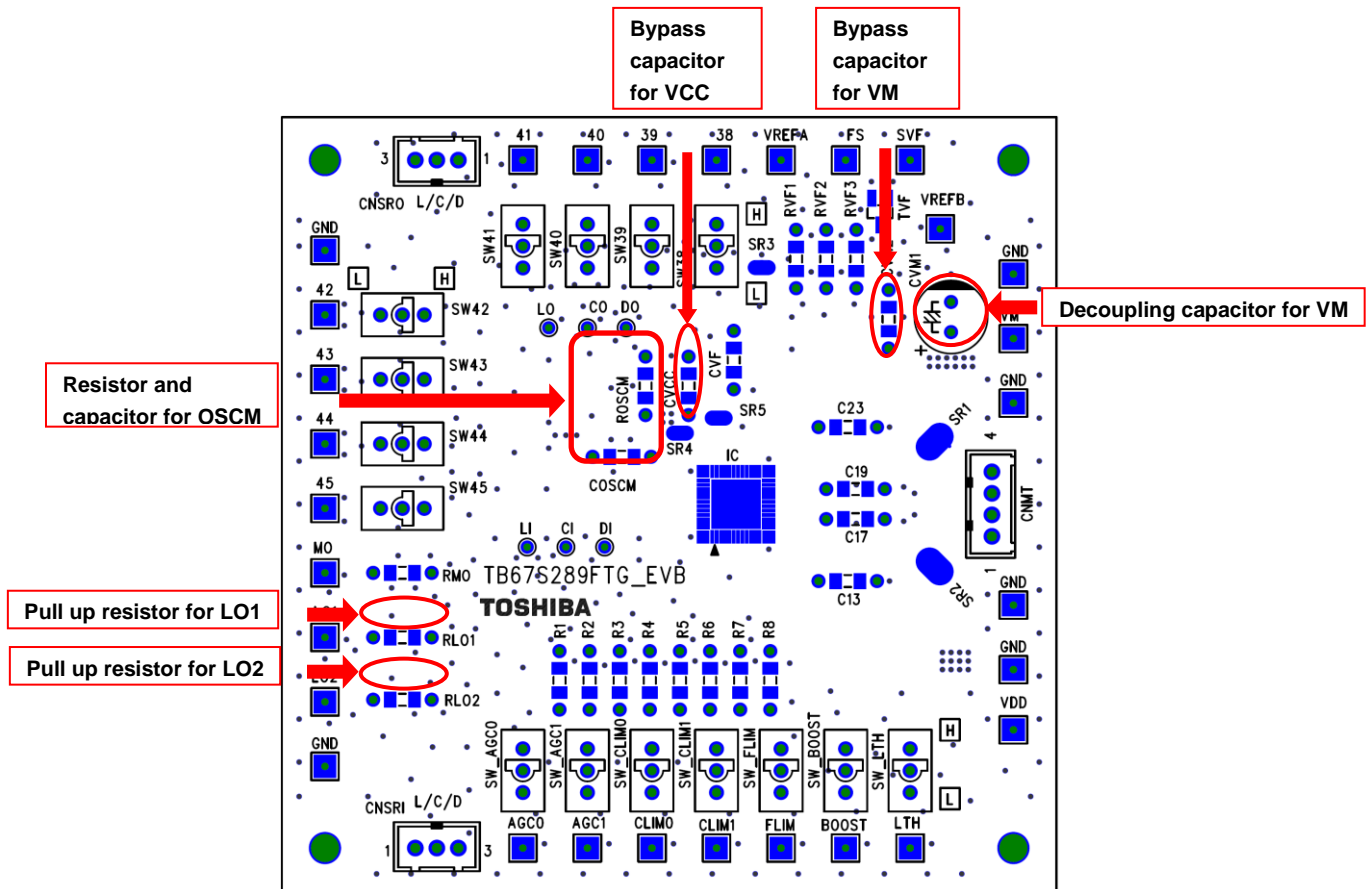
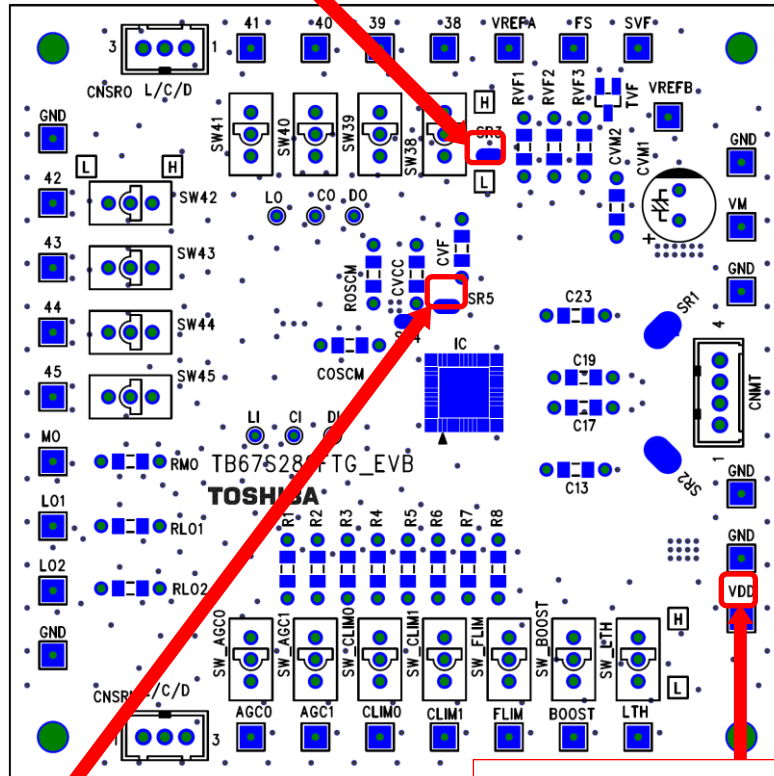

Figure 11.2 Main part

11.3. Options

When VCC is used for high level of the switch and for pull up resistor, connect to SR3. In this case, do not apply voltage to VDD.



When VREFA and VREFB are used as common power supply, connect to SR5. In this case, apply voltage to either of VREFA or VREFB.

When VDD (i.e., external power supply) is used for high level of the switch and for pull up resistor, apply 3.3 V or 5 V to VDD terminal. In this case, do not connect to SR3.

Figure 11.3 Options

11.4. Board circuit diagram

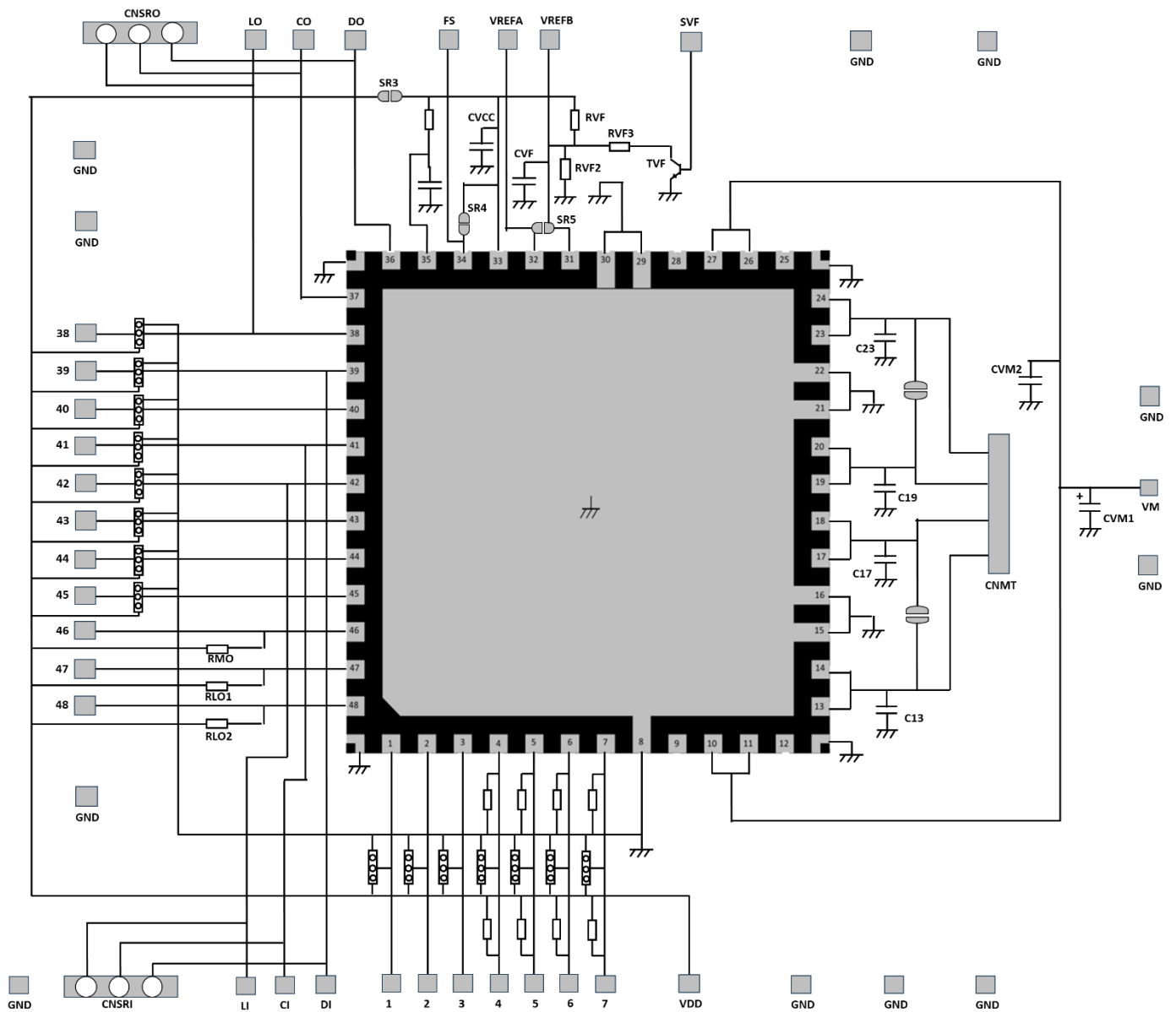

Figure 11.4 Board circuit diagram

Note: Above board is also used for other motor ICs, therefore some parts are not used for the TB67H420FTG.

Notes on Contents

1. Block Diagrams

Some of the functional blocks, circuits, or constants in the block diagram may be omitted or simplified for explanatory purposes.

2. Equivalent Circuits

The equivalent circuit diagrams may be simplified or some parts of them may be omitted for explanatory purposes.

3. Timing Charts

Timing charts may be simplified for explanatory purposes.

4. Application Circuits

The application circuits shown in this document are provided for reference purposes only. Thorough evaluation is required, especially at the mass production design stage.

Any license to any industrial property rights is not granted by provision of these application circuit examples.

5. Test Circuits

Components in the test circuits are used only to obtain and confirm the device characteristics. These components and circuits are not guaranteed to prevent malfunction or failure from occurring in the application equipment.

IC Usage Considerations

Notes on handling of ICs

- (1) The absolute maximum ratings of a semiconductor device are a set of ratings that must not be exceeded, even for a moment. Do not exceed any of these ratings.
Exceeding the rating(s) may cause the device breakdown, damage or deterioration, and may result injury by explosion or combustion.
- (2) Use an appropriate power supply fuse to ensure that a large current does not continuously flow in the case of over current and/or IC failure. The IC will fully break down when used under conditions that exceed its absolute maximum ratings, when the wiring is routed improperly or when an abnormal pulse noise occurs from the wiring or load, causing a large current to continuously flow and the breakdown can lead to smoke or ignition. To minimize the effects of the flow of a large current in the case of breakdown, appropriate settings, such as fuse capacity, fusing time and insertion circuit location, are required.
- (3) If your design includes an inductive load such as a motor coil, incorporate a protection circuit into the design to prevent device malfunction or breakdown caused by the current resulting from the inrush current at power ON or the negative current resulting from the back electromotive force at power OFF. IC breakdown may cause injury, smoke or ignition.
Use a stable power supply with ICs with built-in protection functions. If the power supply is unstable, the protection function may not operate, causing IC breakdown. IC breakdown may cause injury, smoke or ignition.
- (4) Do not insert devices in the wrong orientation or incorrectly.
Make sure that the positive and negative pins of power supplies are connected properly.
Otherwise, the current or power consumption may exceed the absolute maximum rating, and exceeding the rating(s) may cause the device breakdown, damage or deterioration, and may result in injury by explosion or combustion.
In addition, do not use any device that is applied the current with inserting in the wrong orientation or incorrectly even just one time.
- (5) Carefully select external components (such as inputs and negative feedback capacitors) and load

components (such as speakers), for example, power amp and regulator.

If there is a large amount of leakage current such as from input or negative feedback condenser, the IC output DC voltage will increase. If this output voltage is connected to a speaker with low input withstand voltage, over current or IC failure may cause smoke or ignition. (The over current may cause smoke or ignition from the IC itself.) In particular, please pay attention when using a Bridge Tied Load (BTL) connection type IC that inputs output DC voltage to a speaker directly.

Points to remember on handling of ICs

(1) Over current protection Circuit

Over current protection circuits (referred to as current limiter circuits) do not necessarily protect ICs under all circumstances. If the over current protection circuits operate against the over current, clear the over current status immediately.

Depending on the method of use and usage conditions, exceeding absolute maximum ratings may cause the over current protection circuit to operate improperly or IC breakdown may occur before operation. In addition, depending on the method of use and usage conditions, if over current continues to flow for a long time after operation, the IC may generate heat resulting in breakdown.

(2) Thermal Shutdown Circuit

Thermal shutdown circuits do not necessarily protect ICs under all circumstances. If the thermal shutdown circuits operate against the over temperature, clear the heat generation status immediately.

Depending on the method of use and usage conditions, exceeding absolute maximum ratings may cause the thermal shutdown circuit to operate improperly or IC breakdown to occur before operation.

(3) Heat Radiation Design

When using an IC with large current flow such as power amp, regulator or driver, design the device so that heat is appropriately radiated, in order not to exceed the specified junction temperature (T_j) at any time or under any condition. These ICs generate heat even during normal use. An inadequate IC heat radiation design can lead to decrease in IC life, deterioration of IC characteristics or IC breakdown. In addition, when designing the device, take into consideration the effect of IC heat radiation with peripheral components.

(4) Back-EMF

When a motor rotates in the reverse direction, stops or slows abruptly, current flows back to the motor's power supply owing to the effect of back-EMF. If the current sink capability of the power supply is small, the device's motor power supply and output pins might be exposed to conditions beyond the absolute maximum ratings. To avoid this problem, take the effect of back-EMF into consideration in system design.

RESTRICTIONS ON PRODUCT USE

Toshiba Corporation and its subsidiaries and affiliates are collectively referred to as "TOSHIBA".

Hardware, software and systems described in this document are collectively referred to as "Product".

- TOSHIBA reserves the right to make changes to the information in this document and related Product without notice.
- This document and any information herein may not be reproduced without prior written permission from TOSHIBA. Even with TOSHIBA's written permission, reproduction is permissible only if reproduction is without alteration/omission.
- Though TOSHIBA works continually to improve Product's quality and reliability, Product can malfunction or fail. Customers are responsible for complying with safety standards and for providing adequate designs and safeguards for their hardware, software and systems which minimize risk and avoid situations in which a malfunction or failure of Product could cause loss of human life, bodily injury or damage to property, including data loss or corruption. Before customers use the Product, create designs including the Product, or incorporate the Product into their own applications, customers must also refer to and comply with (a) the latest versions of all relevant TOSHIBA information, including without limitation, this document, the specifications, the data sheets and application notes for Product and the precautions and conditions set forth in the "TOSHIBA Semiconductor Reliability Handbook" and (b) the instructions for the application with which the Product will be used with or for. Customers are solely responsible for all aspects of their own product design or applications, including but not limited to (a) determining the appropriateness of the use of this Product in such design or applications; (b) evaluating and determining the applicability of any information contained in this document, or in charts, diagrams, programs, algorithms, sample application circuits, or any other referenced documents; and (c) validating all operating parameters for such designs and applications. **TOSHIBA ASSUMES NO LIABILITY FOR CUSTOMERS' PRODUCT DESIGN OR APPLICATIONS.**
- **PRODUCT IS NEITHER INTENDED NOR WARRANTED FOR USE IN EQUIPMENTS OR SYSTEMS THAT REQUIRE EXTRAORDINARILY HIGH LEVELS OF QUALITY AND/OR RELIABILITY, AND/OR A MALFUNCTION OR FAILURE OF WHICH MAY CAUSE LOSS OF HUMAN LIFE, BODILY INJURY, SERIOUS PROPERTY DAMAGE AND/OR SERIOUS PUBLIC IMPACT ("UNINTENDED USE").** Except for specific applications as expressly stated in this document, Unintended Use includes, without limitation, equipment used in nuclear facilities, equipment used in the aerospace industry, lifesaving and/or life supporting medical equipment, equipment used for automobiles, trains, ships and other transportation, traffic signaling equipment, equipment used to control combustions or explosions, safety devices, elevators and escalators, and devices related to power plant. **IF YOU USE PRODUCT FOR UNINTENDED USE, TOSHIBA ASSUMES NO LIABILITY FOR PRODUCT.** For details, please contact your TOSHIBA sales representative or contact us via our website.
- Do not disassemble, analyze, reverse-engineer, alter, modify, translate or copy Product, whether in whole or in part.
- Product shall not be used for or incorporated into any products or systems whose manufacture, use, or sale is prohibited under any applicable laws or regulations.
- The information contained herein is presented only as guidance for Product use. No responsibility is assumed by TOSHIBA for any infringement of patents or any other intellectual property rights of third parties that may result from the use of Product. No license to any intellectual property right is granted by this document, whether express or implied, by estoppel or otherwise.
- **ABSENT A WRITTEN SIGNED AGREEMENT, EXCEPT AS PROVIDED IN THE RELEVANT TERMS AND CONDITIONS OF SALE FOR PRODUCT, AND TO THE MAXIMUM EXTENT ALLOWABLE BY LAW, TOSHIBA (1) ASSUMES NO LIABILITY WHATSOEVER, INCLUDING WITHOUT LIMITATION, INDIRECT, CONSEQUENTIAL, SPECIAL, OR INCIDENTAL DAMAGES OR LOSS, INCLUDING WITHOUT LIMITATION, LOSS OF PROFITS, LOSS OF OPPORTUNITIES, BUSINESS INTERRUPTION AND LOSS OF DATA, AND (2) DISCLAIMS ANY AND ALL EXPRESS OR IMPLIED WARRANTIES AND CONDITIONS RELATED TO SALE, USE OF PRODUCT, OR INFORMATION, INCLUDING WARRANTIES OR CONDITIONS OF MERCHANTABILITY, FITNESS FOR A PARTICULAR PURPOSE, ACCURACY OF INFORMATION, OR NONINFRINGEMENT.**
- Do not use or otherwise make available Product or related software or technology for any military purposes, including without limitation, for the design, development, use, stockpiling or manufacturing of nuclear, chemical, or biological weapons or missile technology products (mass destruction weapons). Product and related software and technology may be controlled under the applicable export laws and regulations including, without limitation, the Japanese Foreign Exchange and Foreign Trade Law and the U.S. Export Administration Regulations. Export and re-export of Product or related software or technology are strictly prohibited except in compliance with all applicable export laws and regulations.
- Please contact your TOSHIBA sales representative for details as to environmental matters such as the RoHS compatibility of Product. Please use Product in compliance with all applicable laws and regulations that regulate the inclusion or use of controlled substances, including without limitation, the EU RoHS Directive. **TOSHIBA ASSUMES NO LIABILITY FOR DAMAGES OR LOSSES OCCURRING AS A RESULT OF NONCOMPLIANCE WITH APPLICABLE LAWS AND REGULATIONS.**