

32-bit RISC Microcontroller

TXZ Family

Reference Manual

Advanced Programmable Motor Control

Circuit

(A-PMD-C)

Revision 2.0

2018-06

TOSHIBA ELECTRONIC DEVICES & STORAGE CORPORATION

Contents

Preface	5
Related document.....	5
Conventions	6
Terms and Abbreviations	8
1. Outlines	9
2. Configuration.....	10
3. Function and Operation	12
3.1. Clock Supply	12
3.2. Pulse Width Modulation Circuit.....	12
3.2.1. PWM Carrier Generation	12
3.2.2. 3 Phase PWM Wave Generation.....	15
3.3. Conduction Control Circuit.....	18
3.4. Protection Control Circuit.....	20
3.4.1. EMG Protection Control Circuit.....	21
3.4.2. OVV Protection Control Circuit.....	23
3.4.3. Protection control when using the debug tool.....	24
3.5. Dead time Control Circuit.....	25
3.6. Synchronous Trigger Generation Circuit	27
3.7. Buffer Operation.....	29
3.8. Decimation of Execution Buffer Update Timing and Synchronous Trigger Output Timing	31
4. Registers	32
4.1. List of Registers	32
4.2. Details of Registers	33
4.2.1. [PMDxMDEN] (PMD enable register)	33
4.2.2. [PMDxPORTMD] (Port output mode register)	33
4.2.3. [PMDxMDCR] (PMD control register).....	34
4.2.4. [PMDxCARSTA] (PWM carrier status register).....	36
4.2.5. [PMDxBCARI] (Basic carrier register).....	36
4.2.6. [PMDxRATE] (PWM frequency register)	36
4.2.7. PWM duty comparison register.....	37
4.2.7.1. [PMDxCMPU] (PWM duty comparison U register)	37
4.2.7.2. [PMDxCMPV] (PWM duty comparison V register).....	37
4.2.7.3. [PMDxCMPW] (PWM duty comparison W register).....	38
4.2.8. PWM carrier phase difference register	38
4.2.8.1. [PMDxVPWMPH] (V-phase phase difference register).....	38
4.2.8.2. [PMDxWPWMPH] (W-phase phase difference register).....	38
4.2.9. [PMDxMDPOT] (PMD output setting register)	39
4.2.10. [PMDxMDOUT] (PMD conduction control register)	40
4.2.11. [PMDxEMGCR] (EMG control register)	41
4.2.12. [PMDxEMGSTA] (EMG status register).....	42
4.2.13. [PMDxEMGREL] (EMG release register)	42

4.2.14. [PMDxOVVCR] (OVV control register)	43
4.2.15. [PMDxOVVSTA] (OVV status register).....	44
4.2.16. [PMDxDTR] (Dead time register).....	44
4.2.17. Trigger comparison register.....	45
4.2.17.1. [PMDxTRGCMP0] (Trigger comparison 0 register)	45
4.2.17.2. [PMDxTRGCMP1] (Trigger comparison 1 register)	45
4.2.17.3. [PMDxTRGCMP2] (Trigger comparison 2 register)	46
4.2.17.4. [PMDxTRGCMP3] (Trigger comparison 3 register)	46
4.2.18. [PMDxTRGCR] (Trigger control register).....	47
4.2.19. [PMDxTRGSYNCR] (Trigger update timing setting register)	48
4.2.20. [PMDxTRGMD] (Trigger output mode setting register).....	49
4.2.21. [PMDxMBUFCR] (Intermediate buffer control register)	49
5. Precaution for Use	50
6. Revision History	51
RESTRICTIONS ON PRODUCT USE.....	53

List of Figures

Figure 2.1	Block diagram of PMD circuit.....	10
Figure 3.1	PWM carrier generation circuit	13
Figure 3.2	Basic carrier waveform	13
Figure 3.3	Phase shift diagram	14
Figure 3.4	Converted carrier waveform output	15
Figure 3.5	Generation circuit of 3-phase PWM waves	15
Figure 3.6	PWM waveform.....	16
Figure 3.7	Conduction control circuit	18
Figure 3.8	Protection control circuit	20
Figure 3.9	EMG protection control circuit.....	21
Figure 3.10	OVV protection control circuit	23
Figure 3.11	Dead time control circuit	25
Figure 3.12	Dead time circuit	25
Figure 3.13	Dead time correction.....	26
Figure 3.14	Synchronous trigger generation circuit.....	27
Figure 3.15	Triple-buffer update timing example of <i>[PMDxCMPU]</i> register	29
Figure 3.16	Register buffer configuration.....	30
Figure 3.17	Timing example of Decimation control (in the case of <INTPRD>=11)	31

List of Tables

Table 2.1	List of signals	11
Table 3.1	Update control of execution buffers of <UPWMMD>, <VPWMMD>, and <WPWMMD>	14
Table 3.2	Update control of the execution buffers in <i>[PMDxCMPU]</i> , <i>[PMDxCMPV]</i> , and <i>[PMDxCMPW]</i>	16
Table 3.3	Decode circuit outputs according to <i>[PMDxMDOUT]</i> and <i>[PMDxMDCR]<SYNTMD></i> setting	19
Table 3.4	Buffer update timing of Trigger comparison register	28
Table 6.1	Revision history	51

Preface

Related document

Document name
Input/Output Ports
Exception
Clock Control and Operation Mode
Product Information
12-bit Analog to Digital Converter

Conventions

- Numeric formats follow the rules as shown below:
 - Hexadecimal: 0xABC
 - Decimal: 123 or 0d123 – Only when it needs to be explicitly shown that they are decimal numbers.
 - Binary: 0b111 – It is possible to omit the "0b" when the number of bit can be distinctly understood from a sentence.
- "_N" is added to the end of signal names to indicate low active signals.
- It is called "assert" that a signal moves to its active level, "deassert" to its inactive level.
- When two or more signal names are referred, they are described like as [m: n].
Example: S[3: 0] shows four signal names S3, S2, S1 and S0 together.
- The characters surrounded by [] defines the register.
Example: [ABCD]
- "n" substitutes suffix number of two or more same kind of registers, fields, and bit names.
Example: [XYZ1], [XYZ2], [XYZ3] → [XYZn]
- "x" substitutes suffix number or character of units and channels in the Register List.
In case of unit, "x" means A, B, and C ...
Example: [ADACR0], [ADBCR0], [ADCCR0] → [ADxCR0]
In case of channel, "x" means 0, 1, and 2 ...
Example: [T32A0RUNA], [T32A1RUNA], [T32A2RUNA] → [T32AxRUNA]
- The bit range of a register is written like as [m: n].
Example: Bit[3: 0] expresses the range of bit 3 to 0.
- The configuration value of a register is expressed by either the hexadecimal number or the binary number.
Example: [ABCD]<EFG> =0x01 (hexadecimal), [XYZn]<VW> =1 (binary)
- Word and Byte represent the following bit length.
 - Byte: 8 bits
 - Half word: 16 bits
 - Word: 32 bits
 - Double word: 64 bits
- Properties of each bit in a register are expressed as follows:
 - R: Read only
 - W: Write only
 - R/W: Read and Write are possible
- Unless otherwise specified, register access supports only word access.
- The register defined as reserved must not be rewritten. Moreover, do not use the read value.
- The value read from the bit having default value of "-" is unknown.
- When a register containing both of writable bits and read-only bits is written, read-only bits should be written with their default value, In the cases that default is "-", follow the definition of each register.
- Reserved bits of the Write-only register should be written with their default value.
In the cases that default is "-", follow the definition of each register.
- Do not use read-modified-write processing to the register of a definition which is different by writing and read out.

Arm, Cortex and Thumb are registered trademarks of Arm Limited (or its subsidiaries) in the US
and/or elsewhere. All rights reserved.



The Flash memory uses the Super Flash® technology under the license of Silicon Storage Technology, Inc.
Super Flash® is registered trademark of Silicon Storage Technology, Inc.

All other company names, product names, and service names mentioned herein may be trademarks of their
respective companies.

Terms and Abbreviations

Some of abbreviations used in this document are as follows:

ADC	Analog to Digital Converter
A-PMD	Advanced Programmable Motor Control Circuit
PMD	Programmable Motor Control Circuit
PWM	Pulse Width Modulation

1. Outlines

The advanced programmable motor control circuit (hereafter, abbreviated as PMD) can operate as a motor control circuit of 1 channel per unit. The following is a list of functions. The following is a list of functions.

Function Classification	Function	Operation
PWM output	Resolution	The count resolution of PWM carrier: 1/fsys. PWM frequency and duty setting: 15-bit fixed
	PWM carrier generation	The frequency range of the PWM carrier that can be generated is 0.08 to 156.25 kHz (at fsys =80 MHz), and the amplitude is 15-bit width. 4 types of PWM carrier waveform: Triangular waveform, Saw-tooth waveform, Inverse triangular waveform, Inverse saw-tooth waveform. Carrier waveform can be selected for each phase. The phase shift can be done between U and V phases, and between U and W phases in the PWM carriers.
	3-phase PWM wave generation	3-phase PWM is generated by comparing the PWM carrier with the duty setting. 3-phase PWM can be generated by selecting either 3-phase common duty or 3-phase independent duty.
	Conduction control	Each of the U/X, V/Y and W/Z phases can be selected PWM or High/Low output. Upper-phase output or lower-phase output respectively can be set to low-active or high-active. This function has the common PWM carrier waveform and generates independent 3-phase PWM (3-phase complementary PWM).
AD conversion start trigger	Synchronous trigger generation	The AD conversion start trigger can be output at an arbitrary timing synchronized with the PWM carrier.
Protection function	Protection control	Output prohibition function by protection signal input (OFF output or terminal output disabled). 2 types of protect control: EMG, OVV
	Dead time control	The dead time control inserts the dead time for preventing short circuit at switching between the upper and lower phases (U/X, V/Y, W/Z). The complementary PWM is output.
Buffer function	-	PWM period, Duty, Synchronous trigger timing, and 6 port output setting are double-buffered or triple-buffered. These setting can be changed during operation. Selectable update timing of execution buffer: Asynchronous, PWM center, PWM end, PWM center/end Selectable update timing of intermediate buffer: Asynchronous, PWM center, PWM end, PWM 1/4, PWM 3/4
Interrupt request	PWM interrupt	PWM interrupt request is generated at a synchronous timing with the PWM wave. Interrupt timing: PWM center or PWM end Interrupt period: Half PWM period, one PWM period, two PWM period, or four PWM period. Decimation control: Synchronous trigger generation and buffer update can be decimated according to interrupt cycle selection.
	EMG interrupt	This interrupt request is generated by the EMG protection of EMG input.
	OVV interrupt	This interrupt request is generated by the OVV protection of OVV input.

2. Configuration

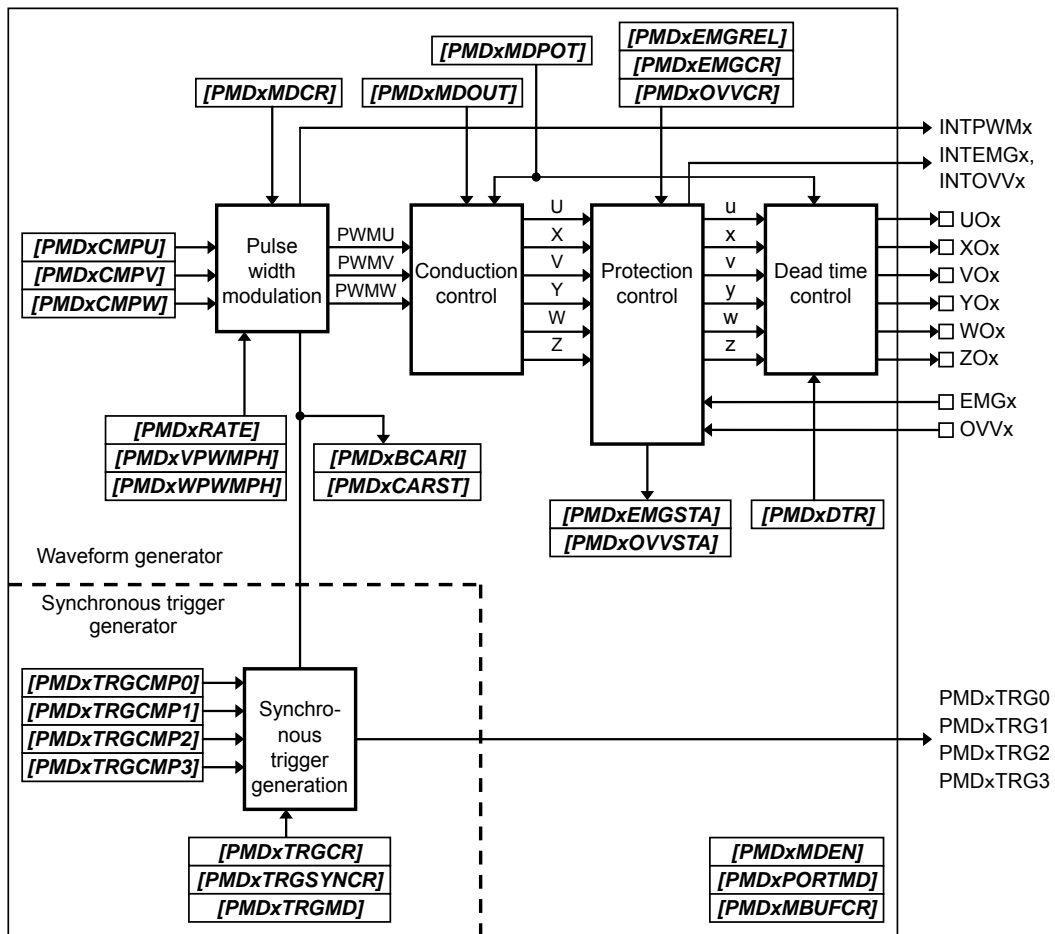

Figure 2.1 Block diagram of PMD circuit

Table 2.1 List of signals

No	Signal name		I/O	Related Reference manual
1	UOx	U-phase output pin	Output	Product Information
2	XOx	X-phase output pin	Output	Product Information
3	VOx	V-phase output pin	Output	Product Information
4	YOx	Y-phase output pin	Output	Product Information
5	WOx	W-phase output pin	Output	Product Information
6	ZOx	Z-phase output pin	Output	Product Information
7	EMGx	EMG detection input	Input	Product Information
8	OVVx	OVV detection input	Input	Product Information
9	PMDxTRG0	ADC synchronous trigger output 0	Output	Product Information
10	PMDxTRG1	ADC synchronous trigger output 1	Output	Product Information
11	PMDxTRG2	ADC synchronous trigger output 2	Output	Product Information
12	PMDxTRG3	ADC synchronous trigger output 3	Output	Product Information
13	INTPWMx	PWM interrupt	Output	Exception
14	INTEMGx	EMG interrupt	Output	Exception
15	INTOVVx	OVV interrupt	Output	Exception

3. Function and Operation

PMD circuit consists of a wave generation circuit and a synchronous trigger generation circuit. The wave generation circuit includes a pulse width modulation circuit, a conduction control circuit, a protection control circuit, and a dead time control circuit.

- The pulse width modulation circuit generates PWM carrier waveforms and generates independent 3-phase PWM waveforms.
- The conduction control circuit determines the output patterns of the upper and lower phases of U, V, and W phases.
- The protection control circuit stops the outputs in emergency case when EMG or OVV signal is received.
- The dead time control circuit prevents from short-circuit at switching between the upper and lower phases.
- The synchronous trigger generation circuit generates 4 channel synchronous trigger signals to ADC.

3.1. Clock Supply

When you use PMD, please set an applicable clock enable bit to "1" (clock supply) in Clock supply and stop register A for fsys (*[CGFSYSENA]*, *[CGFSYSMENA]*), Clock supply and stop register B for fsys (*[CGFSYSENB]*, *[CGFSYSMENB]*), and Clock supply and stop register for fc (*[CGFCEN]*).

An applicable register and the bit position vary according to a product. Therefore, the register may not exist with the product. Please refer to "Clock Control and Operation Mode" of the reference manual for the details.

3.2. Pulse Width Modulation Circuit

The pulse width modulation circuit consists of a PWM carrier generation circuit and 3-phase PWM generation circuit.

3.2.1. PWM Carrier Generation

The PWM carrier generation circuit integrates *[PMDxRATE]* register value to generate a basic carrier (saw-tooth wave), and generates each PWM carrier of 3 phases using the basic carrier.

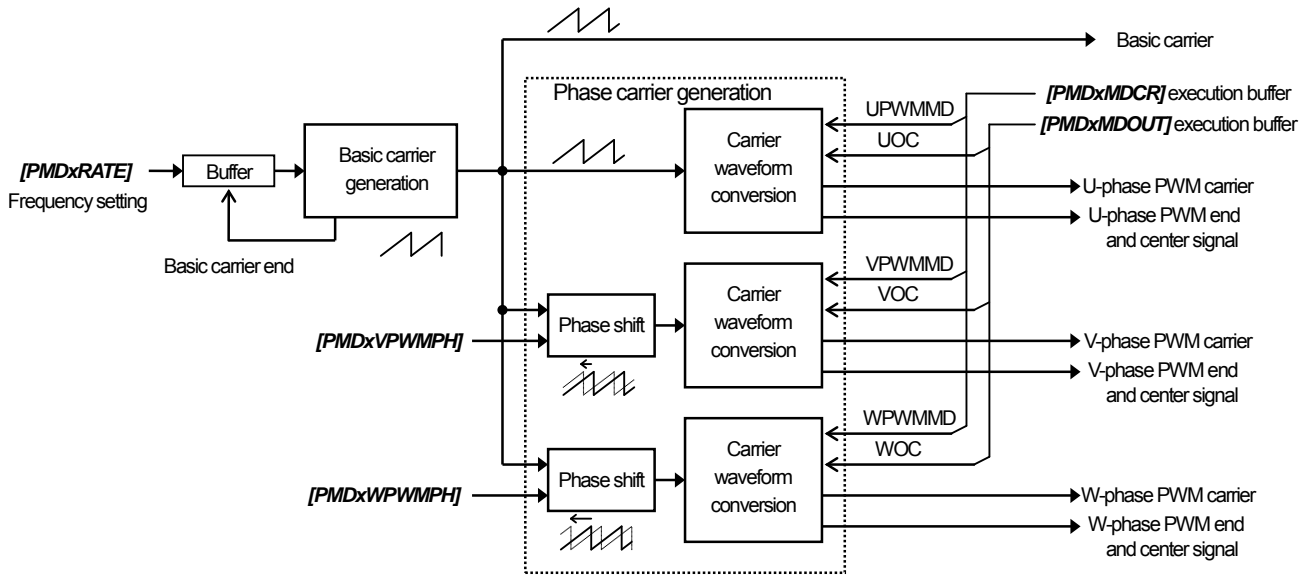

Figure 3.1 PWM carrier generation circuit

- Basic carrier generation

The PWM frequency should be set in `[PMDxRATE]` register. `[PMDxRATE]` register has a double-buffer structure. The execution buffer is updated every basic carrier end (refer to "4.2.6 `[PMDxRATE]` (PWM frequency register)").

The PWM frequency is calculated with the following formula:

$$\text{PWM frequency} = \frac{f_{\text{sys}} [\text{Hz}]}{2^{24} / [\text{PMDxRATE}] \text{ value}}$$

Note: The decimal fraction is rounded off in the denominator.

The amplitude of the basic carrier is the same even when the frequency is changed, as shown in Figure 3.2.

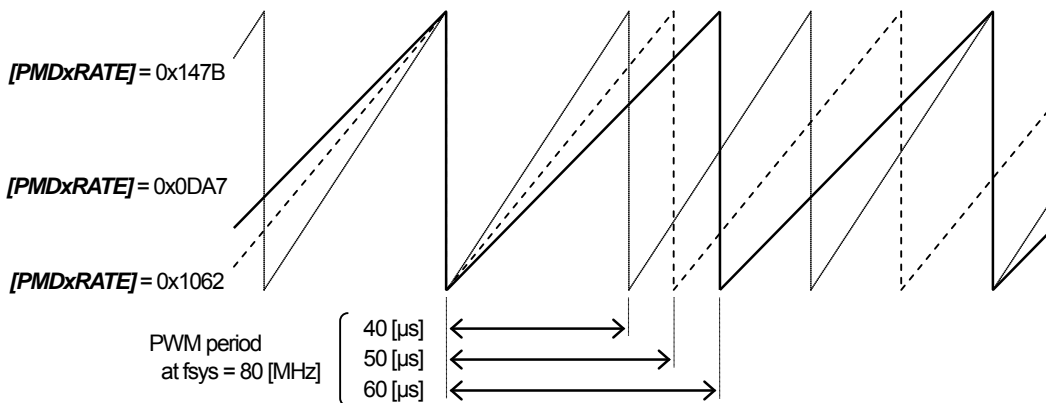

Figure 3.2 Basic carrier waveform

- Phase shift

The phase shift can be done between U and V phases, and between U and W phases in the PWM carriers. $[PMDxVPWMPH]$ and $[PMDxWPWMPH]$ registers can set the phase differences between U and V phases, and between U and W phases, respectively (refer to Figure 3.3). The setting value of the phase shift is (the ratio to the PWM period) $\times 2^{15}$.

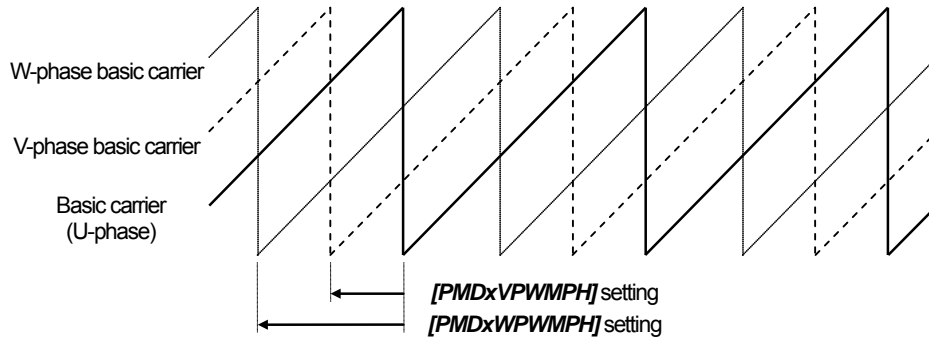

Figure 3.3 Phase shift diagram

- Each phase carrier generation

Each PWM phase carrier can select its waveform using the settings of $\langle UPWMMD \rangle$, $\langle VPWMMD \rangle$, and $\langle WPWMMD \rangle$ in $[PMDxMDCR]$ register. $\langle UPWMMD \rangle$, $\langle VPWMMD \rangle$, and $\langle WPWMMD \rangle$ fields have a triple-buffer structure. The update timing of the execution buffer is shown in Table 3.1. For the update of the intermediate buffer, refer to "3.7 Buffer Operation".

The waveform of the PWM carrier can be selected from among a saw-tooth wave, a triangular wave, an inverse saw-tooth wave, and an inverse triangular wave (refer to Figure 3.4). And the PWM carrier waveform is inverted if the conduction setting $[PMDxMDOUT]\langle UOC \rangle/\langle VOC \rangle/\langle WOC \rangle$ is set to "00".

Table 3.1 Update control of execution buffers of $\langle UPWMMD \rangle$, $\langle VPWMMD \rangle$, and $\langle WPWMMD \rangle$

Setting $[PMDxMDPOT]\langle PSYNCS \rangle$	Update Timing
00	Asynchronous with PWM
01	Update at each PWM center
10	Update at each PWM end
11	Update at each PWM end and center

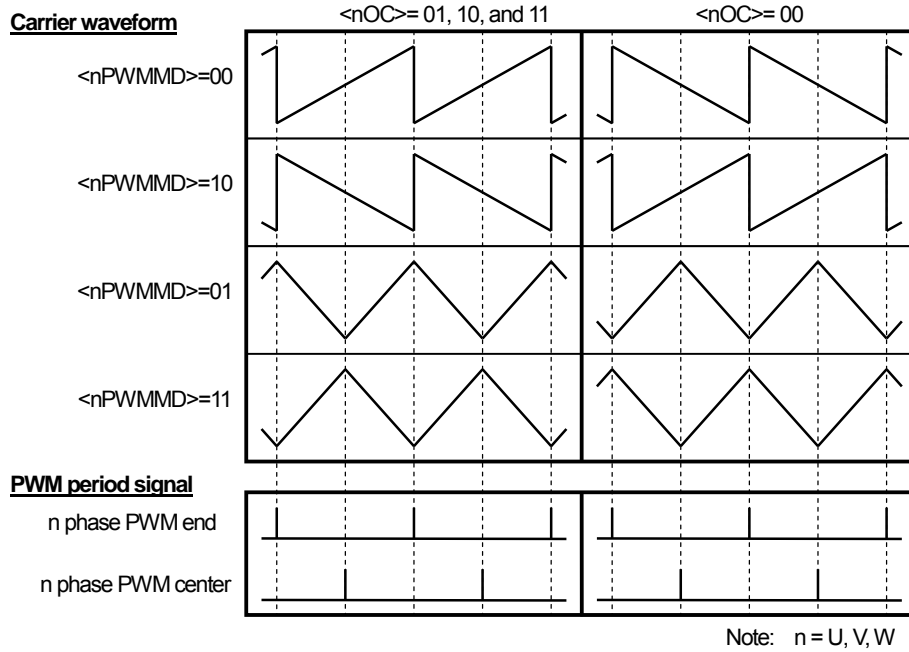

Figure 3.4 Converted carrier waveform output

3.2.2. 3 Phase PWM Wave Generation

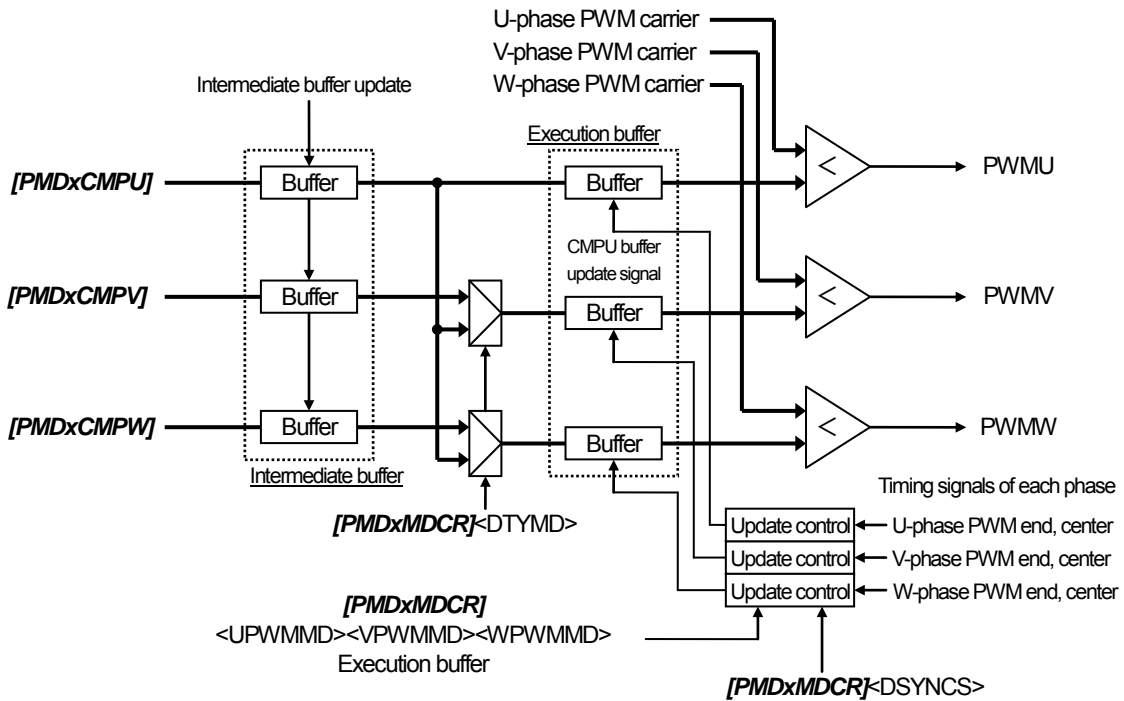

Figure 3.5 Generation circuit of 3-phase PWM waves

- Comparison function

3 comparators compare the magnitudes of 3-phase PWM carries with the values in 3-phase PWM duty comparison registers ($[PMDxCMPI]$, $[PMDxCMPV]$, and $[PMDxCMPW]$), respectively, to generate PWM waves which have the expected duties.

Each phase PWM duty comparison register has a triple-buffer structure. The value of each phase PWM duty comparison register is loaded to the execution buffer at a synchronous timing with the PWM period. The update at the half of the PWM period (Load every half period) can be selected (refer to Table 3.2). For the update of the intermediate buffer, refer to "3.7 Buffer Operation".

Table 3.2 Update control of the execution buffers in $[PMDxCMPI]$, $[PMDxCMPV]$, and $[PMDxCMPW]$

$[PMDxMDCR]$ setting		Update timing
<DSYNCS>	<INTPRD>	
00	01, 10, 11	Update at each PWM end
	00	Update at each PWM end and center
01	xx	Update at each PWM center
10	xx	Update at each PWM end
11	xx	Update at each PWM end and center

Note: xx: Don't care

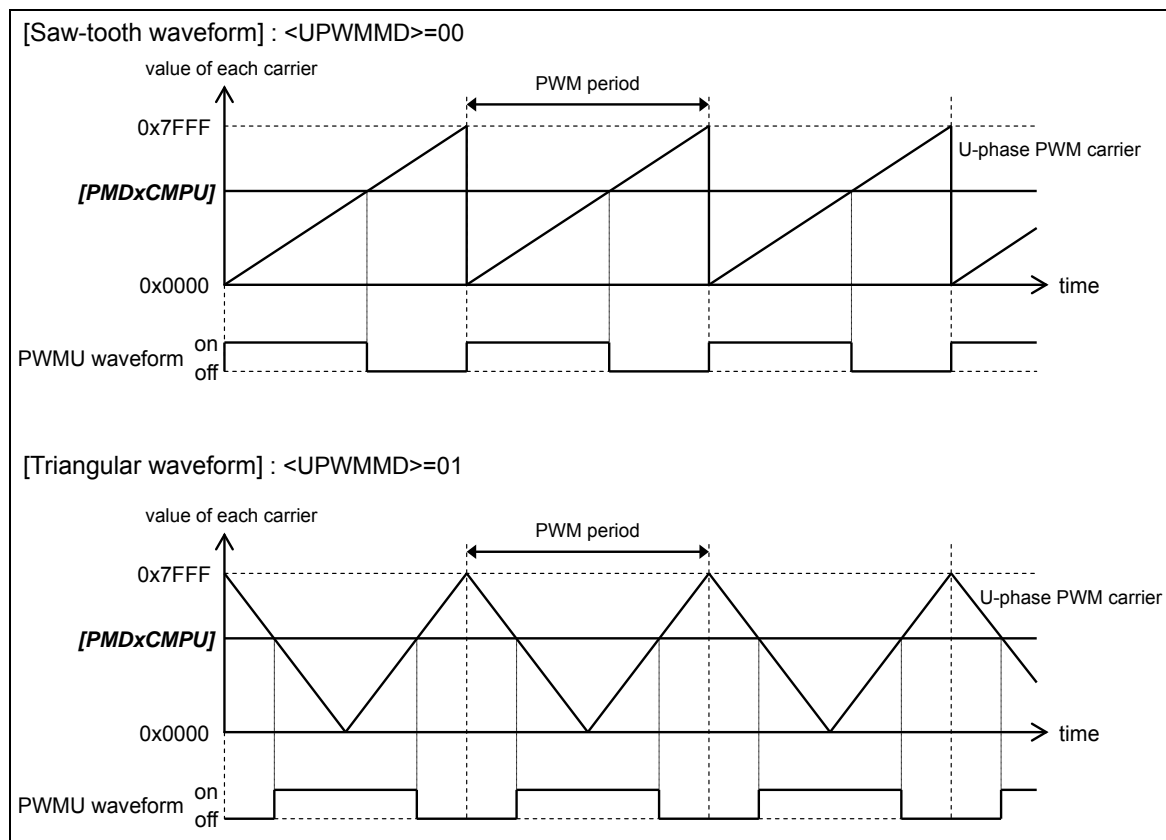

Figure 3.6 PWM waveform

- Waveform mode

3-phase PWM waveforms can be generated in the following 2 modes by the duty mode selection [*PMDxMDCR*]*<DTYMD>*.

- 3-phase independent duty mode:
3-phase PWM duty comparison registers are set to different values, respectively. Each PWM wave is generated independently. This mode is used to generate arbitrary driving waves such as sine waves.
- 3-phase common duty mode:
Only U-phase PWM duty comparison register is used. The register value controls all 3-phase PWM waves. These PWM waves become the same. This mode is used for the pulse control to drive a brushless DC motor.

- Interrupt procedure

The pulse width modulation circuit generates a PWM interrupt request at a synchronous timing with the PWM period. The timing of the interrupt generation can be selected between U-phase PWM end and U-phase PWM center.

The frequency of the PWM interrupt can be selected from among every half of the PWM period, every PWM period, every second PWM period, and every fourth PWM period.

3.3. Conduction Control Circuit

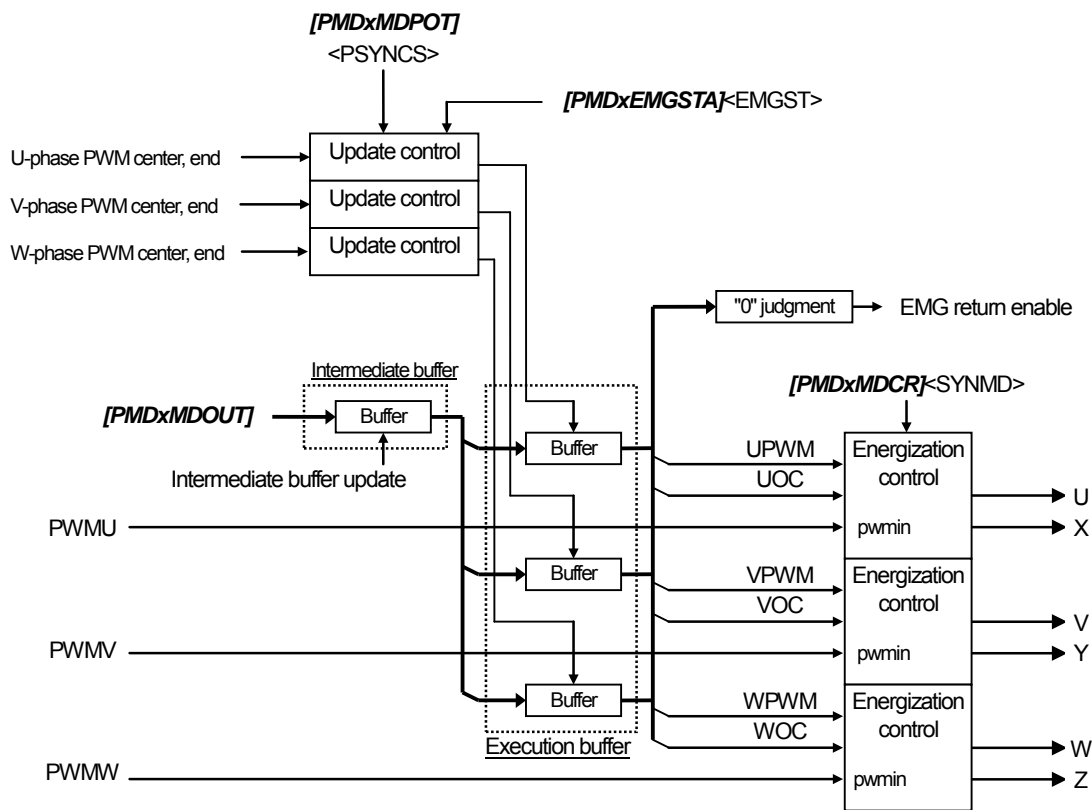

Figure 3.7 Conduction control circuit

The output ports are controlled by the settings of the PMD conduction control register $[PMDxMDOUT]$ and the PMD output setting register $[PMDxMDPOT]$. $[PMDxMDOUT]$ has a triple-buffer structure. The update timing of its execution buffer can be selected between a synchronous timing with PWM period and an asynchronous one. And the update timing which is synchronous with the trigger input can also be set. The update timing is selected $[PMDxMDPOT]$ $\langle PSYNCS \rangle$.

Each of 6 port outputs (Upper-phase output, UOx, VOx, and WOx, and Lower-phase output, XOx, YOx, and ZOx) can be set separately to Low active output and High active output by $[PMDxMDPOT]$ $\langle POLH \rangle$ and $\langle POLL \rangle$, respectively (Refer to "3.5 Dead time Control Circuit"). And, each phase of U, V, and W can select between PWM output and High/Low level output using $[PMDxMDOUT]$ $\langle WPWM \rangle$, $\langle VPWM \rangle$, and $\langle UPWM \rangle$, respectively. When PWM output is selected, PWM wave is output, and when High/Low output is selected, High level or Low level is output. The selection of High or Low is done by $[PMDxMDOUT]$ $\langle WOC \rangle$, $\langle VOC \rangle$, and $\langle UOC \rangle$, respectively. Table 3.3 shows the port outputs determined by the settings of the port output set by $[PMDxMDOUT]$ and $[PMDxMDPOT]$, and also by the setting of the port output mode set by PMD control register $[PMDxMDCR]$.

Table 3.3 Decode circuit outputs according to $[PMDxMDOUT]$ and $[PMDxMDCR]<SYNTMD>$ setting

$[PMDxMDCR]<SYNTMD>=0$

		PWM output setting $[PMDxMDOUT]<nPWM>$			
		0: H/L output		1: PWM output	
		Upper-phase	Lower-phase	Upper-phase	Lower-phase
Conduction setting $[PMDxMDOUT]$ $<nOC>$	00	Low	Low	PWM	PWM_N
	01	Low	High	Low	PWM
	10	High	Low	PWM	Low
	11	High	High	PWM	PWM_N

$[PMDxMDCR]<SYNTMD>=1$

		PWM output setting $[PMDxMDOUT]<nPWM>$			
		0: H/L output		1: PWM output	
		Upper-phase	Lower-phase	Upper-phase	Lower-phase
Conduction setting $[PMDxMDOUT]$ $<nOC>$	00	Low	Low	PWM	PWM_N
	01	Low	High	Low	PWM_N
	10	High	Low	PWM	Low
	11	High	High	PWM	PWM_N

Note: n= U, V, W

3.4. Protection Control Circuit

The protection control circuit consists of a protection control unit and a protect output control unit.
The protection control unit consists of EMG protection control and OVV protection control circuits.

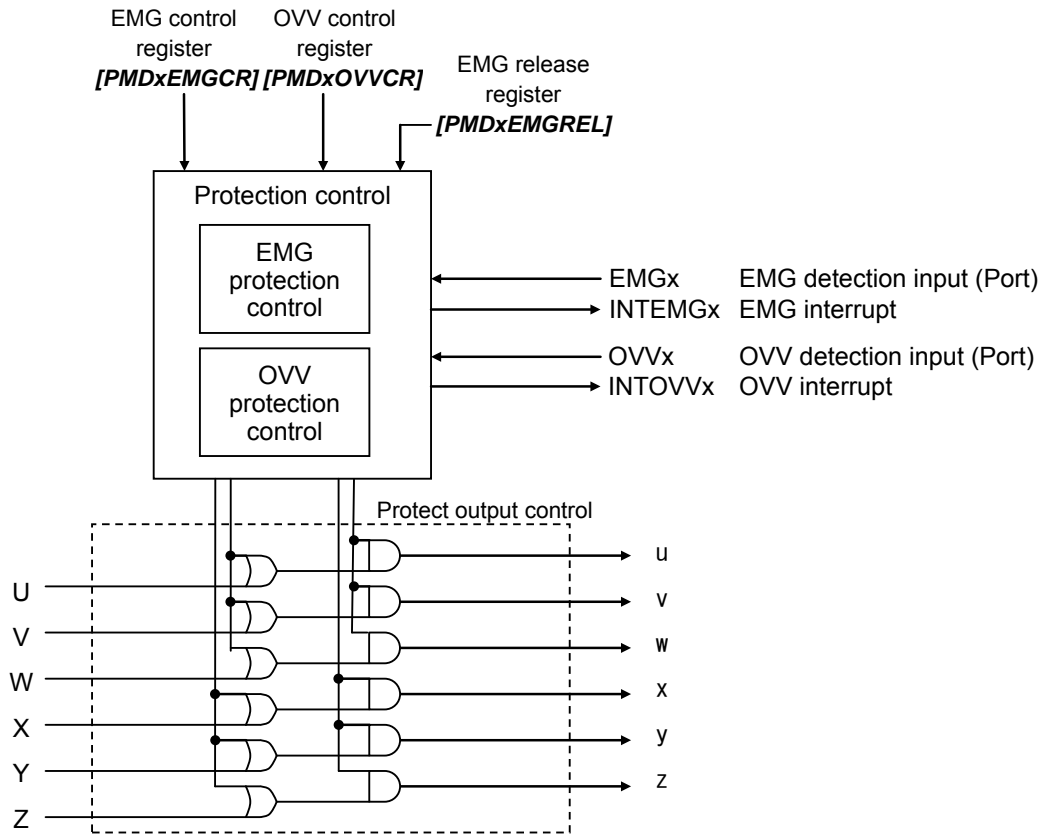

Figure 3.8 Protection control circuit

3.4.1. EMG Protection Control Circuit

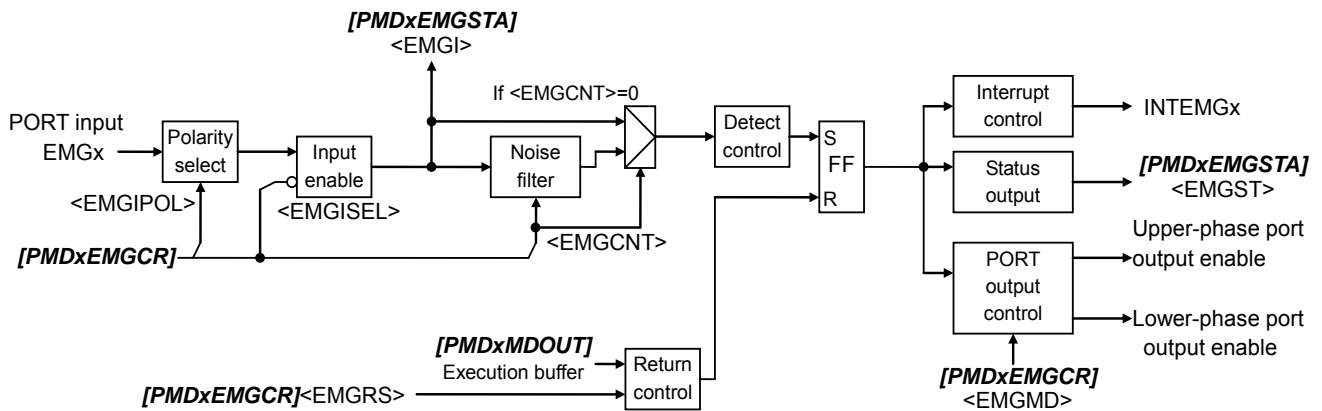

Figure 3.9 EMG protection control circuit

EMG protection control circuit is for emergency stop. The protection is enabled by $[PMDxEMGCR] \langle EMGEN \rangle = 1$. When EMG input becomes active, the protection starts operating. The EMG protection is set by EMG control register $[PMDxEMGCR]$.

Note: After reset, the EMG protection control circuit is enabled.

- EMG input

EMGx pin is enabled / disabled as EMG input by $[PMDxEMGCR] \langle EMGISEL \rangle$. The active level is selected by $[PMDxEMGCR] \langle EMGIPOL \rangle$ (EMGx input polarity selection).

The noise filter is inserted in the EMG input. The noise detection time is selected with the EMG input detection time setting ($[PMDxEMGCR] \langle EMGCNT \rangle$). When $\langle EMGCNT \rangle = 0$ setting, the noise filter is bypassed.

Note: If $\langle EMGCNT \rangle$ and $\langle EMGIPOL \rangle$ is changed while EMG protection control circuit is enabled, it may become the protection state. Therefore, when these are changed, please execute "Return of the EMG protection".

- EMG protection operation

When EMG input is active for a predetermined period (set by $\langle EMGCNT \rangle$), all 6 PWM outputs can be disabled immediately and EMG interrupt (INTEMGx) is generated. According to the setting of $[PMDxEMGCR] \langle EMGMD \rangle$, the external output port status during protection operation is selected from all phase high-impedance, all lower-phase high-impedance / all upper-phase ON, all upper-phase high-impedance / all lower-phase ON.

When $[PMDxEMGSTA] \langle EMGST \rangle$ is "1", the device is in EMG protection state.

- Return from the EMG protection

If all the port outputs are set to inactive ($[PMDxMDOUT]<UPWM>$, $<VPWM>$, $<WPWM>$, $<UOC>$, $<VOC>$, and $<WOC>$ are all "0") in EMG protection state and then $[PMDxEMGCR]<EMGRS>$ is set to "1", the device return from EMG protection state. When, however, EMG input is active, writing "1" to $<EMGRS>$ is ignored. The return procedure should be done after EMG input becomes inactive. It is confirmed with reading $[PMDxEMGSTA]<EMGI>$.

Note: EMG return procedure after the reset deassertion

EMGx pin is shared with a data port. The pin is the data port after the reset deassertion. EMG protection control circuit is enabled at the initial state. So, EMC protection may be active. The return of EMG protection state should be done as follows in the initial sequence:

- (1) EMG function should be selected by the port function register ($[PxFRn]$).
 - (2) $[PMDxEMGSTA]<EMGI>$ should be read to confirm its value is "1".
 - (3) $[PMDxMDOUT]<UPWM>$, $<VPWM>$, $<WPWM>$, $<UOC>$, $<VOC>$, and $<WOC>$ should be set to "0" to set all port outputs to inactive state.
 - (4) $[PMDxEMGCR]<EMGRS>$ should be set to "1" to exit EMG protection state.
- Disable of the EMG protection function

In order to disable EMG function, EMG release register $[PMDxEMGREL]$ should be set to "0x5A" and "0xA5" in order, then $[PMDxEMGCR]<EMGEN>$ should be set to "0". These 3 instructions should be executed continuously to prevent from a wrong setting of the disable.

3.4.2. OVV Protection Control Circuit

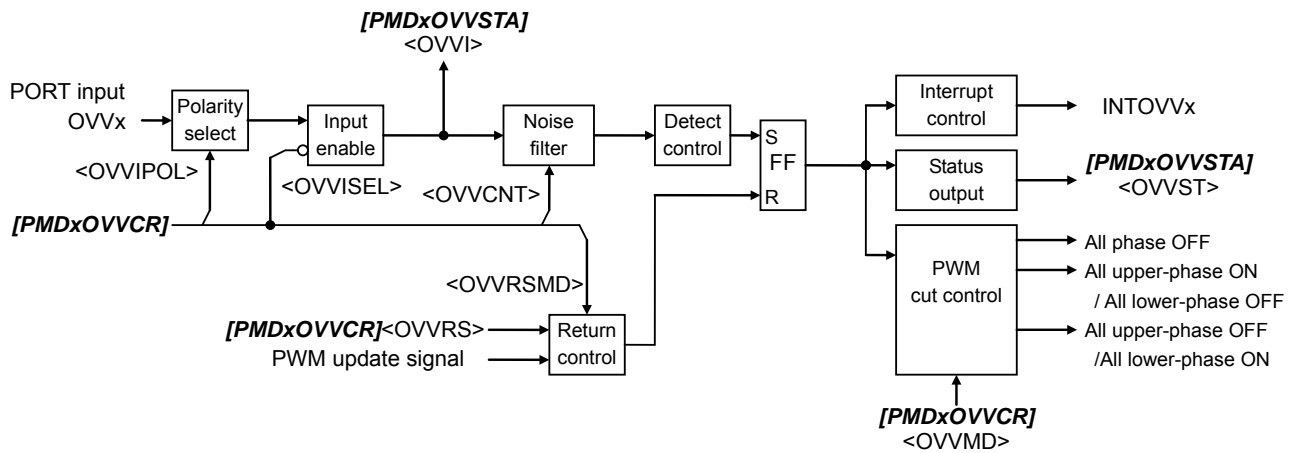

Figure 3.10 OVV protection control circuit

The OVV protection control circuit is enabled by $[PMDxOVVCR] \langle OVVEN \rangle = 1$. When OVV input becomes active, the protection starts operating. This protection is set by OVV control register ($[PMDxOVVCR]$).

- OVV input

OVVx pin is enabled / disabled as OVV input by $[PMDxOVVCR] \langle OVVISEL \rangle$. The active level is selected by $\langle OVVIPOL \rangle$ in OVVx input (Port) polarity selection register.

The noise filter is inserted in the OVV input. The noise detection time is selected with the OVV input detection time setting ($[PMDxOVVCR] \langle OVVCNT \rangle$).

Note: If $\langle OVVCNT \rangle$ and $\langle OVVIPOL \rangle$ is changed while OVV protection control circuit is enabled, it may become the protection state. Therefore, when these are changed, please execute "Return of the OVV protection".

- OVV protection operation

OVV protection control circuit fixes 6 port outputs in the conduction control block to High level or Low level, when OVV input is active for a predetermined period (set by $\langle OVVCNT \rangle$). And OVV interrupt (INTOVVx) is generated. $[PMDxOVVCR] \langle OVVMD \rangle$ setting selects from among all lower-phase OFF/all upper-phase ON, all upper-phase OFF/all lower-phase ON, and all phase OFF.

When $[PMDxOVVSTA] \langle OVVST \rangle$ is "1", the device is in OVV protection state.

- Return from the OVV protection

When $[PMDxOVVCR]<OVVRS>$ is set to "1", the device returns from OVV protection state. When, however, OVV input is active, writing "1" to $<OVVRS>$ is ignored. The return procedure should be done after OVV input becomes inactive. It is confirmed with reading $[PMDxOVVSTA]<OVVI>$.

When OVV return operation selection $<OVVRSMD>=0$, the auto return is enabled. After OVV input becomes inactive, the return is done at the synchronous timing with U-phase PWM period (the state of the port can be checked by reading $[PMDxOVVSTA]<OVVI>$). The device returns automatically from OVV protection state at U-phase PWM end. When, however, half PWM period interrupt is set, the timing is the PWM end and center.

- Disable of the OVV protection control circuit

In order to disable OVV function, EMG release register $[PMDxEMGREL]$ should be set to "0x5A" and "0xA5" in order, then $[PMDxOVVCR]<OVVEN>$ should be set to "0". These 3 instructions should be executed continuously to prevent the OVV protection control circuit from being inadvertently disabled.

3.4.3. Protection control when using the debug tool

When using the debug tool, PMD output ports can be disabled when PMD is stopped by the debug halt. However, when the EMG occurs, port outputs are controlled depending by setting the $[PMDxEMGCR]<EMGMMD[1:0]>$.

In the debug halt, whether the port output becomes high-impedance or PMD output is selected by $[PMDxPORTMD]<PORTMD>$ setting.

3.5. Dead time Control Circuit

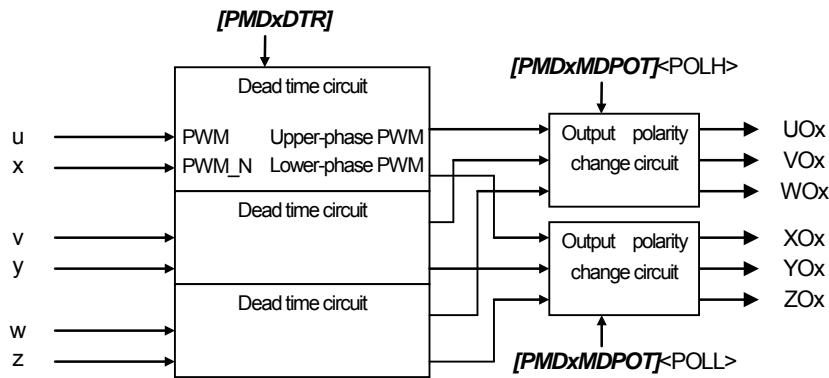

Figure 3.11 Dead time control circuit

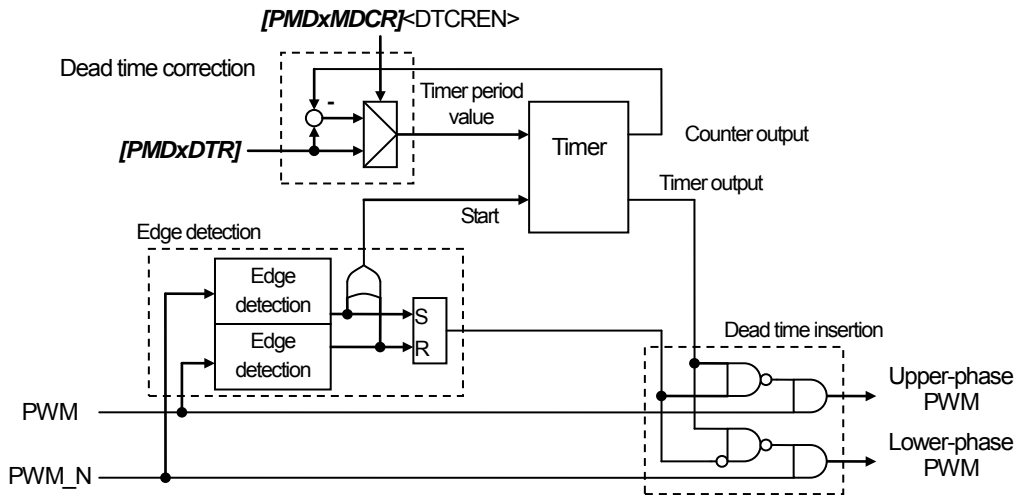

Figure 3.12 Dead time circuit

The dead time control circuit consists of a dead time circuit and an output polarity change circuit. The dead time circuit includes an edge detection block, a timer block, a dead time insertion block, and a dead time correction block (refer to Figure 3.12).

The dead time circuit delays ON timing to prevent from the short-circuit between the upper-phase and the lower-phase for U, V, and W phases, when both the upper-phase and the lower-phase invert their signals at the same time. The unit of the delay time is $4/f_{sys}$ (50 ns at 80 MHz, 10-bit resolution). The delay time is set to the dead time register *[PMDxDTR]*.

The output polarity change circuit can select High-active or Low-active for Upper-phase output (UOx, VOx, and WOx) and Lower-phase output (XOx, YOx, and ZOx) independently. The selection is done by PMD output setting register *[PMDxMDPOT]<POLH>* and *<POLL>*, respectively.

The dead time correction circuit operates as follows: When *[PMDxMDCR]<DTCREN>* is set to "1" and one of Upper-phase PWM and Lower-phase PWM has 0 ON time, the delay time of the other PWM is shortened. If PWM output changes to OFF during the dead time interval, the dead time correction function shortens the delay time of the opposite phase by the remaining dead time interval ("Dead time register setting value" - "ON interval"). That is, when Upper-phase PWM output changes to OFF during the dead time interval, the delay time of Lower-phase PWM is shortened. When Lower-phase PWM output changes to OFF during the dead time interval,

the delay time of Upper-phase PWM is shortened. The delay time is corrected near 100% duty of Upper-phase PWM or near 0% duty of Lower-phase PWM, as shown in Figure 3.13.

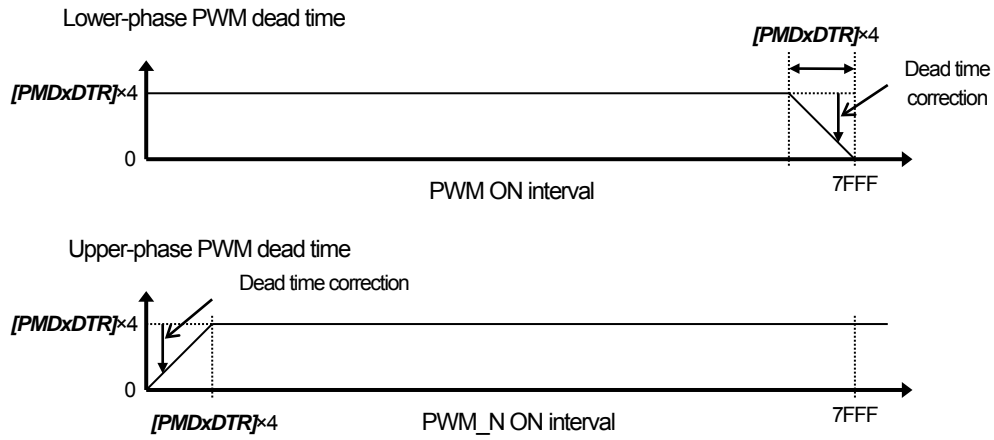

Figure 3.13 Dead time correction

3.6. Synchronous Trigger Generation Circuit

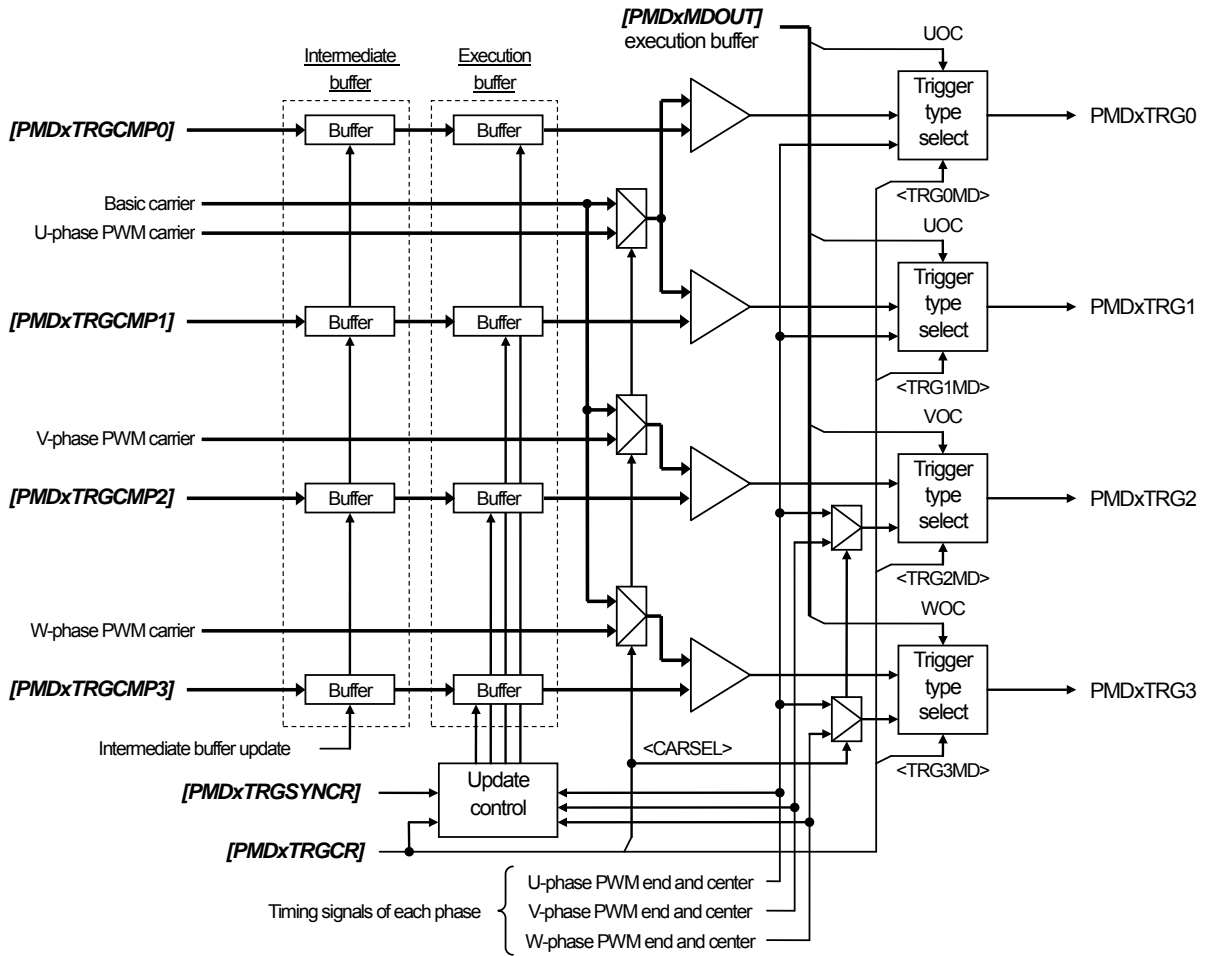

Figure 3.14 Synchronous trigger generation circuit

The synchronous trigger generation circuit generates 4 trigger signals ($PMDxTRG0$ to $PMDxTRG3$) which are synchronous with each phase PWM carrier and are used to sample ADC data.

The trigger timing can be selected from among the followings:

- (1) Coincident time in the first half of a triangular wave carrier (Note1)(Note2)
- (2) Coincident time in the second half of a triangular wave carrier (Note1)(Note2)
- (3) Coincident times in the first and second halves of a triangular wave carrier (Note1)(Note2)
- (4) PWM end of the basic carrier or each phase carrier (Note2)(Note3)
- (5) PWM center of the basic carrier or each phase carrier (Note2)(Note3)
- (6) PWM center and end of the basic carrier or each phase carrier (Note2)(Note3)

Note1: Coincidence of the basic carrier or each phase carrier and $[PMDxTRGCMPn]$ value.

Note2: When saw-tooth wave ($[PMDxMDCR] < UPWMMD > / < VPWMMD > / < WPWMMD > = 00, 10$)
There is no distinction between the first half and the second half.
The trigger does not occur at the PWM center and it occurs at the PWM end.

Note3: When comparing the basic carrier, it becomes U-phase PWM center / end timing.

Trigger compare registers are triple-buffer configuration. The execution buffer update timing is shown in the table below. For the update timing of the intermediate buffer, refer to "3.7 Buffer Operation".

Table 3.4 Buffer update timing of Trigger comparison register

<i>[PMDxTRGSYNCR]</i> <TSYNCS> Setting	<i>[PMDxTRGCR]</i> <TRGnMD> Setting	<i>[PMDxTRGCMPn]</i> Register Buffer Update Timing
00	000	Immediate update
	001	Update at each phase PWM end (Note1)
	010	Update at each phase PWM center (Note1)(Note2)
	011	Update at each phase PWM end and center (Note1)(Note2)
	1xx	Immediate update
01	xxx	Update at each phase PWM center (Note1)(Note2)
10	xxx	Update at each phase PWM end (Note1)
11	xxx	Update at each phase PWM end and center (Note1)(Note2)

Note 1: When comparing the basic carrier, it becomes U-phase PWM center / end timing.

Note 2: When PWM carrier is a saw-tooth wave

(*[PMDxMDCR]*<UPWMMD>/<VPWMMD>/<WPWMMD>= 00 or 10), the update is done at the PWM end.

Note 3: xxx: Don't care

Note 4: When *[PMDxMDEN]*<PWMEN>=0, the immediate update is done regardless of the setting.

If the trigger output is enabled in EMG protection state, *[PMDxTRGMD]*<EMGTGE> should be set to "1".

3.7. Buffer Operation

The buffer configuration of a register has a single-buffer, double-buffer, and triple-buffer.

[PMDxRATE] register is a double-buffer one. *[PMDxMDOUT]*, *[PMDxCMPU]*, *[PMDxCMPV]*, *[PMDxCMPW]*, *[PMDxTRGCMP0]*, *[PMDxTRGCMP1]*, *[PMDxTRGCMP2]*, and *[PMDxTRGCMP3]* registers, and *[PMDxMDCR]*<UPWMMD>, <VPWMMD>, and <WPWMMD> have triple-buffer. The other registers are single-buffer ones. The double-buffer structure has a register stage and an execution buffer stage. And the triple-buffer structure has an intermediate buffer stage between the register stage and the execution stage.

The intermediate stage can be updated at the timing selected by *[PMDxMBCFTR]*<BUFCTR>. When <BUFCTR>=000, the intermediate stage is bypassed.

The update timing of the execution buffer stage can be set per register independently. For the details of the setting, refer to each register description.

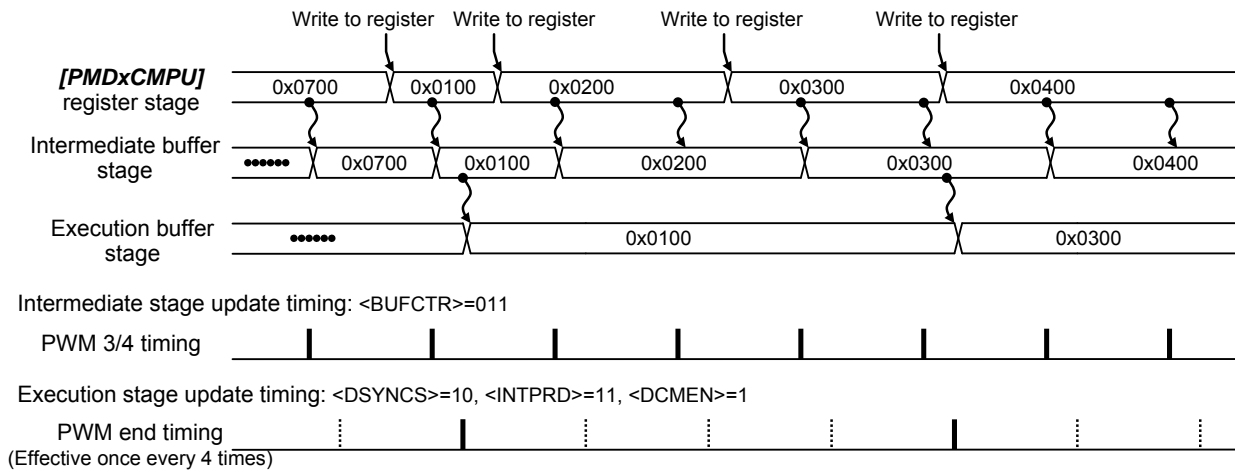

Figure 3.15 Triple-buffer update timing example of *[PMDxCMPU]* register

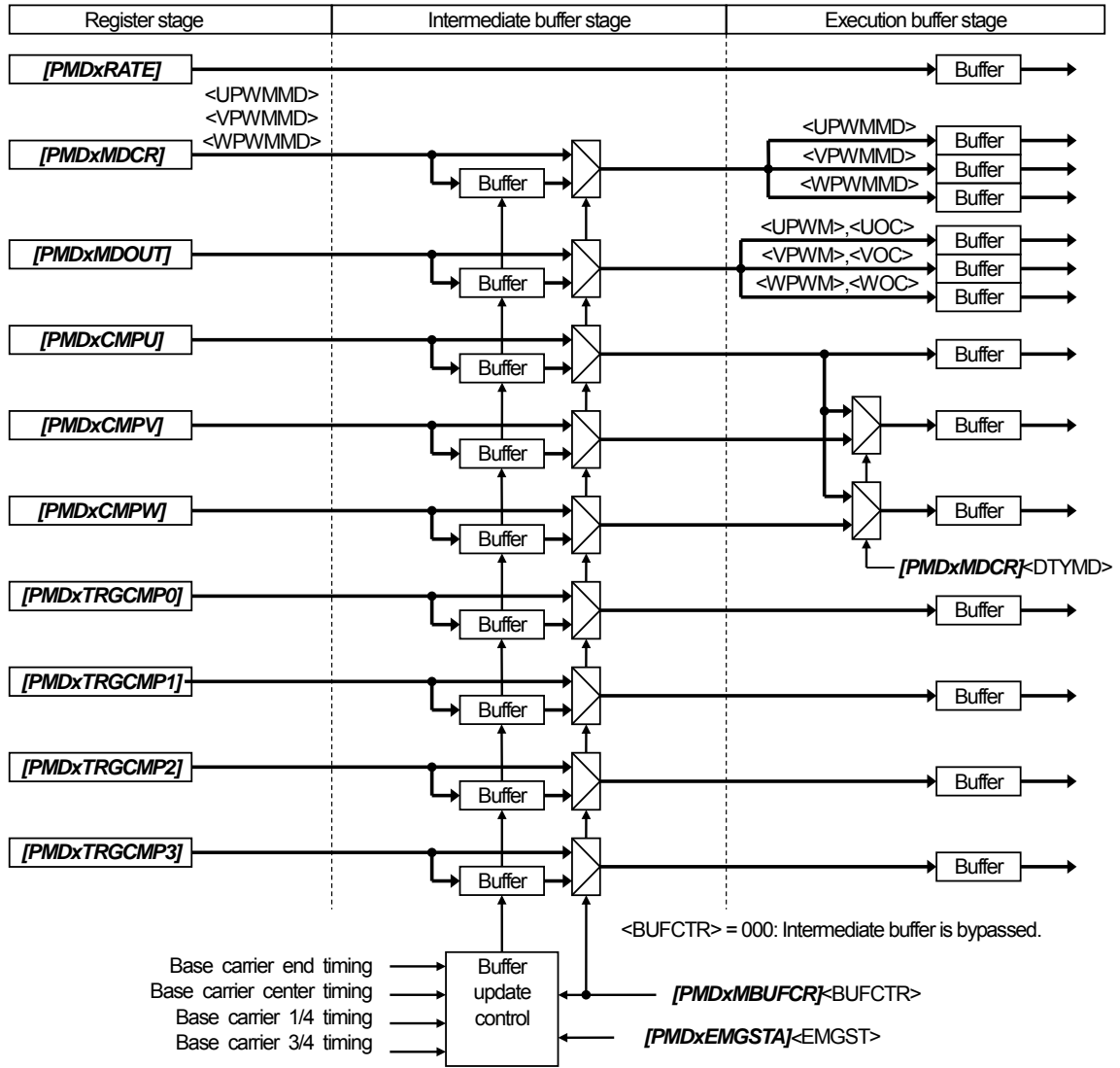

Figure 3.16 Register buffer configuration

3.8. Decimation of Execution Buffer Update Timing and Synchronous Trigger Output Timing

The update of the execution buffer and the trigger output usually occurs once in a PWM period. When the interrupt period is selected to two PWM periods or more, the update timing of the execution buffer and the ADC synchronous trigger output can be decimated.

When $[PMDxMDCR] \langle INTPRD \rangle = 10$ or 11 , the decimation control can be enabled by the setting $[PMDxMDCR] \langle DCMEN \rangle$ to "1".

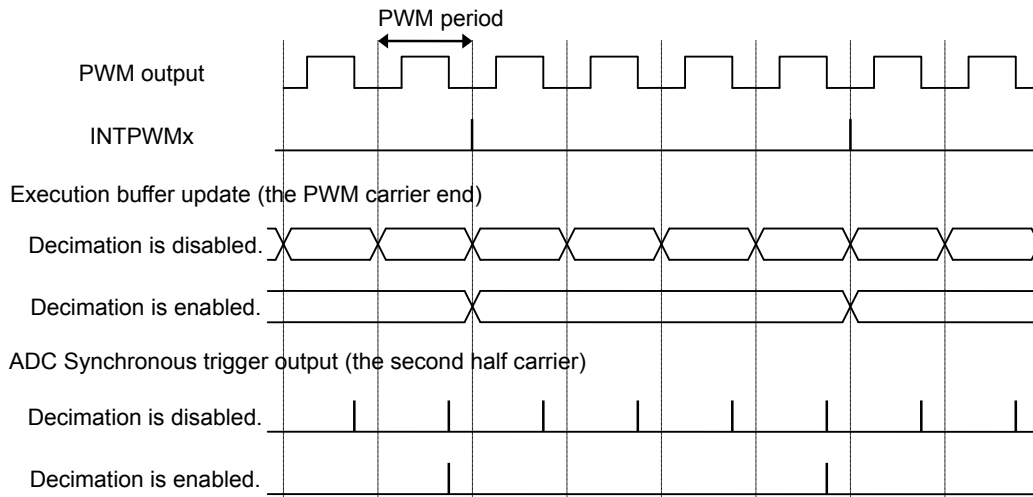

Figure 3.17 Timing example of Decimation control (in the case of $\langle INTPRD \rangle = 11$)

4. Registers

4.1. List of Registers

The control registers and their addresses are shown as follows.

Peripheral Function		Channel/Unit	Base Address		
			TYPE1	TYPE2	TYPE3
Advanced programmable motor control circuit	A-PMD	ch0	0x400F6000	0x400E9000	0x40089000
		ch1	0x400F6100	0x400E9400	0x40089400
		ch2	0x400F6200	0x400E9800	0x40089800
		ch3	0x400F6300	0x400E9C00	0x40089C00

Note: The channel/unit and base address type are different by products. Please refer to "Product Information" of the reference manual for the details.

Register Name		Address (Base+)
PMD enable register	[PMDxMDEN]	0x0000
Port output mode register	[PMDxPORTMD]	0x0004
PMD control register	[PMDxMDCR]	0x0008
PWM carrier status register	[PMDxCARSTA]	0x000C
Basic carrier register	[PMDxBCARI]	0x0010
PWM frequency register	[PMDxRATE]	0x0014
PWM duty comparison U register	[PMDxCMPU]	0x0018
PWM duty comparison V register	[PMDxCMPV]	0x001C
PWM duty comparison W register	[PMDxCMPW]	0x0020
Reserved	-	0x0024
PMD conduction control register	[PMDxMDOUT]	0x0028
PMD output setting register	[PMDxMDPOT]	0x002C
EMG release register	[PMDxEMGREL]	0x0030
EMG control register	[PMDxEMGCR]	0x0034
EMG status register	[PMDxEMGSTA]	0x0038
OVV control register	[PMDxOVVCR]	0x003C
OVV status register	[PMDxOVVSTA]	0x0040
Dead time register	[PMDxDTR]	0x0044
Trigger comparison 0 register	[PMDxTRGCMP0]	0x0048
Trigger comparison 1 register	[PMDxTRGCMP1]	0x004C
Trigger comparison 2 register	[PMDxTRGCMP2]	0x0050
Trigger comparison 3 register	[PMDxTRGCMP3]	0x0054
Trigger control register	[PMDxTRGCR]	0x0058
Trigger output mode setting register	[PMDxTRGMD]	0x005C
Reserved	-	0x0060
Trigger update timing setting register	[PMDxTRGSYNCR]	0x0064
V-phase phase difference register	[PMDxVPWMPH]	0x0068
W-phase phase difference register	[PMDxWPWMPH]	0x006C
Intermediate buffer control register	[PMDxMBUFCR]	0x0070
Reserved	-	0x0074
Reserved	-	0x0078

4.2. Details of Registers

4.2.1. [PMDxMDEN] (PMD enable register)

Bit	Bit Symbol	After Reset	Type	Description
31:1	-	0	R	Read as "0"
0	PWMEN	0	R/W	Wave composition function is enabled or disabled. 0: Disabled. 1: Enabled.

Note 1: When the port is set to the function output (PWM output), the port output is disabled (High-impedance) at <PWMEN>=0.

Note 2: <PWMEN>=1 should be set after initial settings other than <PWMEN> like an output polarity are set.

4.2.2. [PMDxPORTMD] (Port output mode register)

Bit	Bit Symbol	After Reset	Type	Description
31:2	-	0	R	Read as "0"
1:0	PORTMD[1:0]	00	R/W	Setting of the port control at debug halt 00: Upper-phase High-impedance / Lower-phase High-impedance 01: Upper-phase High-impedance / Lower-phase PMD output 10: Upper-phase PMD output / Lower-phase High-impedance 11: Upper-phase PMD output / Lower-phase PMD output This field sets the port outputs of Upper-phases (UOx/VOx/WOx) and Lower-phases (XOx/YOx/ZOx) at occurrence of debug halt while the port is set to the function output (PWM output). At occurrence of debug halt while "High-impedance" is selected, the port output is disabled (High-impedance). Otherwise, the output follows PMD output.

Note 1: The output is disabled (High-impedance) at [PMDxMDEN]<PWMEN>=0, regardless of <PORTMD> setting.

Note 2: The port control is done by the setting of [PMDxEMGCR]<EMGMD> at EMG input mode, too.

Note 3: For the input/output port setting, refer to "Input/Output Ports" of the reference manual.

4.2.3. [PMDxMDCR] (PMD control register)

Bit	Bit Symbol	After Reset	Type	Description
31:16	-	0	R	Read as "0"
15:14	WPWMMD[1:0]	00	R/W	W-phase PWM carrier wave selection (Note 1)(Note 2)(Note 3)(Note 4) 00: Saw-tooth wave (Edge PWM) 01: Triangle wave (Center PWM) 10: Reversed saw-tooth wave (Edge PWM) 11: Reversed triangular wave (Center PWM)
13:12	VPWMMD[1:0]	00	R/W	V-phase PWM carrier wave selection (Note 1)(Note 2)(Note 3)(Note 4) 00: Saw-tooth wave (Edge PWM) 01: Triangle wave (Center PWM) 10: Reversed saw-tooth wave (Edge PWM) 11: Reversed triangular wave (Center PWM)
11:10	UPWMMD[1:0]	00	R/W	U-phase PWM carrier wave selection (Note 1)(Note 2)(Note 3)(Note 4) 00: Saw-tooth wave (Edge PWM) 01: Triangle wave (Center PWM) 10: Reversed saw-tooth wave (Edge PWM) 11: Reversed triangular wave (Center PWM)
9:8	DSYNCS[1:0]	00	R/W	Update timing of the execution buffer in PWM duty comparison register (Note 6)(Note 8) 00: The timing depends on the interrupt period setting (INTPRD). (Refer to Table 3.2.) When the half period interrupt request is selected (<INTPRD>=00), the update is done at each phase PWM end and center. Otherwise, at PWM end. 01: Update at each phase PWM center. 10: Update at each phase PWM end. 11: Update at each phase PWM end and center.
7	DTCREN	0	R/W	Dead time correction enable 0: Disabled. 1: Enabled.
6	DCMEN	0	R/W	Decimation control of the execution buffer update and the synchronous trigger output When 2 period interrupt or 4 period interrupt is selected (<INTPRD>= 10 or 11), the decimation control is enabled for the update timing of the execution buffer and the synchronous trigger output. 0: Disabled. 1: Enabled. The target buffers are [PMDxCMPU]/[PMDxCMPV]/[PMDxCMPW], [PMDxTRGCMP0]/[PMDxTRGCMP1]/[PMDxTRGCMP2] / [PMDxTRGCMP3], [PMDxMDOUT], and [PMDxMDCR]<UPWMMD>/<VPWMMD>/<WPWMMD>.
5	SYNTMD	0	R/W	Port output mode setting This bit controls the port output with the combination of [PMDxMDOUT] <UOC>/<VOC>/<WOC>/<UPWM>/<VPWM>/<WPWM>, [PMDxMDPOT] <POLH>/<POLL>, and <SYNTMD> (Refer to Table 3.3).
4	DTYMD	0	R/W	Duty mode selection 0: Common for 3 phases. 1: Independent for each phase. The duty setting is selected between the independent setting ([PMDxCMPU]/[PMDxCMPV]/[PMDxCMPW]) or the common setting for 3 phases ([PMDxCMPU]).
3	PINT	0	R/W	PWM interrupt request timing selection (Note 6)(Note 7) 0: Interrupt request is generated at U-phase PWM center. 1: Interrupt request is generated at U-phase PWM end.

Bit	Bit Symbol	After Reset	Type	Description
2:1	INTPRD[1:0]	00	R/W	PWM interrupt request period selection 00: Request at every PWM half period (Note 5) 01: Request at every PWM 1 period 10: Request at every PWM 2 periods 11: Request at every PWM 4 periods The frequency of PWM interrupt request is selected from among half PWM period, 1 PWM period, 2 PWM periods, and 4 PWM periods. Execution buffer update timing and trigger output can be decimated out according to interrupt request period selection. (refer to "3.8 Decimation of Execution Buffer Update Timing and Synchronous Trigger Output Timing".)
0	-	0	R	Read as "0"

Note 1: The update can be done while PWM counter is operating owing to the triple-buffer structure.

Note 2: The update timing of the execution buffer is selected [*PMDxMDPOT*]*<PSYNCS>*.

Note 3: For the update timing of the intermediate buffer, refer to "3.7 Buffer Operation".

Note 4: When this field is read, the value of the register stage (the data set through the bus) returns.

Note 5: It is valid when the triangular wave carrier is selected (*<UPWMMD>/<VPWMMD>/<WPWMMD>= 01, 11*).

Note 6: When the saw-tooth wave carrier is selected (*<UPWMMD>/<VPWMMD>/<WPWMMD>= 00, 10*), the update is done at the PWM end, regardless of the setting.

Note 7: When the interrupt period is a half period (*<INTPRD>=00*), the update is done at both the PWM end and center.

Note 8: When [*PMDxMDEN*]*<PWMEN>=0*, the asynchronous update is done regardless of the setting.

4.2.4. [PMDxCARSTA] (PWM carrier status register)

Bit	Bit Symbol	After Reset	Type	Description
31:3	-	0	R	Read as "0"
2	PMMWST	0	R	W-phase PWM carrier state 0: First half W-phase PWM period 1: Second half W-phase PWM period
1	PMMVST	0	R	V-phase PWM carrier state 0: First half V-phase PWM period 1: Second half V-phase PWM period
0	PMMUST	0	R	U-phase PWM carrier state 0: First half U-phase PWM period 1: Second half U-phase PWM period

4.2.5. [PMDxBCARI] (Basic carrier register)

Bit	Bit Symbol	After Reset	Type	Description
31:15	-	0	R	Read as "0"
14:0	BCARI[14:0]	0x0000	R	Read of the basic carrier Counter value resolution is 1/fsys (12.5 ns at fsys =80 MHz). The carrier value at PMD disable ([PMDxMDEN]<PWMEN>=0) is [PMDxRATE] / 2 ¹⁰ .

4.2.6. [PMDxRATE] (PWM frequency register)

Bit	Bit Symbol	After Reset	Type	Description
31:15	-	0	R	Read as "0"
14:0	RATE[14:0]	0x0000	R/W	PWM frequency setting RATE ≥ 0x0010 PWM frequency = fsys x <RATE> value / 2 ²⁴ The setting value is calculated with the following formula: (PWM frequency) / fsys x 2 ²⁴

Note 1: When a value less than "0x0010" is set, it is automatically replaced with "0x0010" (the register stores the setting value).

Note 2: The byte write (upper 8 bits ([15:8]) and lower 8 bits ([7:0]) are written separately) should not be done. When the byte write is done, the operation cannot be guaranteed.

Note 3: [PMDxRATE] register can be updated while the PWM counter is operating, because it has a double-buffer structure.

Note 4: The update timing of the execution buffer is the basic carrier end timing. When, however, [PMDxMDEN]<PWMEN>=0 or [PMDxMDPOT]<PSYNCS>=00, the update is done at any time.

Note 5: When this field is read, the value of the register stage (the data set through the bus) returns.

4.2.7. PWM duty comparison register

4.2.7.1. [PMDxCMPU] (PWM duty comparison U register)

Bit	Bit Symbol	After Reset	Type	Description
31:16	-	0	R	Read as "0"
15:0	CMPU[15:0]	0x0000	R/W	U-phase PWM duty ratio setting 0x0000 to 0x8000 Determines U-phase PWM duty ratio. U-phase PWM carrier is compared with the execution buffer value to output the PWM which has the setting duty ratio.

Note 1: For $\langle \text{CMPU} \rangle \geq 0x8000$, the duty ratio is 100 %.

Note 2: The byte write (upper 8 bits ([15:8]) and lower 8 bits ([7:0]) are written separately) should not be done. When the byte write is done, the operation cannot be guaranteed.

Note 3: [PMDxCMPU] register can be updated while the PWM counter is operating, because it has a triple-buffer structure.

Note 4: For the update timing of the execution buffer, refer to "Table 3.2 Update control of the execution buffers in [PMDxCMPU], [PMDxCMPV], and [PMDxCMPW]".

Note 5: For the update timing of the intermediate buffer, refer to "3.7 Buffer Operation".

Note 6: When this field is read, the value of the register stage (the data set through the bus) returns.

4.2.7.2. [PMDxCMPV] (PWM duty comparison V register)

Bit	Bit Symbol	After Reset	Type	Description
31:16	-	0	R	Read as "0"
15:0	CMPV[15:0]	0x0000	R/W	V-phase PWM duty ratio setting 0x0000 to 0x8000 Determines V-phase PWM duty ratio. V-phase PWM carrier is compared with the execution buffer value to output the PWM which has the setting duty ratio.

Note 1: For $\langle \text{CMPV} \rangle \geq 0x8000$, the duty ratio is 100 %.

Note 2: The byte write (upper 8 bits ([15:8]) and lower 8 bits ([7:0]) are written separately) should not be done. When the byte write is done, the operation cannot be guaranteed.

Note 3: [PMDxCMPV] register can be updated while the PWM counter is operating, because it has a triple-buffer structure.

Note 4: For the update timing of the execution buffer, refer to "Table 3.2 Update control of the execution buffers in [PMDxCMPU], [PMDxCMPV], and [PMDxCMPW]".

Note 5: For the update timing of the intermediate buffer, refer to "3.7 Buffer Operation".

Note 6: When this field is read, the value of the register stage (the data set through the bus) returns.

4.2.7.3. [PMDxCMPW] (PWM duty comparison W register)

Bit	Bit Symbol	After Reset	Type	Description
31:16	-	0	R	Read as "0"
15:0	CMPW[15:0]	0x0000	R/W	W-phase PWM duty ratio setting 0x0000 to 0x8000 Determines W-phase PWM duty ratio. W-phase PWM carrier is compared with the execution buffer value to output the PWM which has the setting duty ratio.

Note 1: For <CMPW> ≥ 0x8000, the duty ratio is 100 %.

Note 2: The byte write (upper 8 bits ([15:8]) and lower 8 bits ([7:0]) are written separately) should not be done. When the byte write is done, the operation cannot be guaranteed.

Note 3: [PMDxCMPW] register can be updated while the PWM counter is operating, because it has a triple-buffer structure.

Note 4: For the update timing of the execution buffer, refer to "Table 3.2 Update control of the execution buffers in [PMDxCMPU], [PMDxCMPV], and [PMDxCMPW]".

Note 5: For the update timing of the intermediate buffer, refer to "3.7 Buffer Operation".

Note 6: When this field is read, the value of the register stage (the data set through the bus) returns.

4.2.8. PWM carrier phase difference register

4.2.8.1. [PMDxVPWMPH] (V-phase phase difference register)

Bit	Bit Symbol	After Reset	Type	Description
31:15	-	0	R	Read as "0"
14:0	VPWMPH[14:0]	0x0000	R/W	V-phase PWM carrier phase difference setting 0x0000 to 0x7FFF The phase difference from the basic carrier is set.

Note: The byte write (upper 8 bits ([15:8]) and lower 8 bits ([7:0]) are written separately) should not be done. When the byte write is done, the operation cannot be guaranteed.

4.2.8.2. [PMDxWPWMPH] (W-phase phase difference register)

Bit	Bit Symbol	After Reset	Type	Description
31:15	-	0	R	Read as "0"
14:0	WPWMPH[14:0]	0x0000	R/W	W-phase PWM carrier phase difference setting 0x0000 to 0x7FFF The phase difference from the basic carrier is set.

Note: The byte write (upper 8 bits ([15:8]) and lower 8 bits ([7:0]) are written separately) should not be done. When the byte write is done, the operation cannot be guaranteed.

4.2.9. [PMDxMDPOT] (PMD output setting register)

Bit	Bit Symbol	After Reset	Type	Description
31:10	-	0	R	Read as "0"
9:8	-	00	R/W	Write as "00"
7:4	-	0	R	Read as "0"
3	POLH	0	R/W	Selection of the output polarity of the upper-phase outputs (UOx, VOx, and WOx). 0: Low active. 1: High active.
2	POLL	0	R/W	Selection of the output polarity of the lower-phase outputs (XOx, YOx, and ZOx). 0: Low active 1: High active.
1:0	PSYNCS[1:0]	00	R/W	Selection of the update timing of the execution buffer in [PMDxMDOUT] and [PMDxMDCR]<UPWMMD>/<VPWMMD>/<WPWMMD>. 00: Asynchronous with PWM. 01: Each phase PWM center 10: Each phase PWM end 11: Each phase PWM end and center The update timing of the conduction control register buffer is selected. (Note 2)(Note 3)

Note 1: This register should be set during [PMDxMDEN]<PWMEN>=0.

Note 2: When PMD disable ([PMDxMDEN]<PWMEN>=0) or EMG protection state, the update timing is an asynchronous one regardless of the setting.

Note 3: When PWM carrier is a saw-tooth wave ([PMDxMDCR]<UPWMMD>/<VPWMMD>/<WPWMMD>= 00 or 10), setting except "00" is PWM end update.

4.2.10. [PMDxMDOUT] (PMD conduction control register)

Bit	Bit Symbol	After Reset	Type	Description
31:11	-	0	R	Read as "0"
10	WPWM	0	R/W	W-phase PWM output setting 0: H/L output 1: PWM output The port output is controlled by the combination of this bit, <WOC>, <WPWM>, [PMDxMDPOT]<POLH>/<POLL>, and [PMDxMDCR]<SYNTMD>. (Refer to Table 3.3.)
9	VPWM	0	R/W	V-phase PWM output setting 0: H/L output 1: PWM output The port output is controlled by the combination of this bit, <VOC>, <VPWM>, [PMDxMDPOT]<POLH>/<POLL>, and [PMDxMDCR]<SYNTMD>. (Refer to Table 3.3.)
8	UPWM	0	R/W	U-phase PWM output setting 0: H/L output 1: PWM output The port output is controlled by the combination of this bit, <UOC>, <UPWM>, [PMDxMDPOT]<POLH>/<POLL>, and [PMDxMDCR]<SYNTMD>. (Refer to Table 3.3.)
7:6	-	0	R	Read as "0"
5:4	WOC[1:0]	00	R/W	W-phase conduction control setting The port output is controlled by the combination of this bit, <WOC>, <WPWM>, [PMDxMDPOT]<POLH>/<POLL>, and [PMDxMDCR]<SYNTMD>. (Refer to Table 3.3.) When <WOC>=00, W-phase carrier wave is reversed.
3:2	VOC[1:0]	00	R/W	V-phase conduction control setting The port output is controlled by the combination of this bit, <VOC>, <VPWM>, [PMDxMDPOT]<POLH>/<POLL>, and [PMDxMDCR]<SYNTMD>. (Refer to Table 3.3.) When <VOC>=00, V-phase carrier wave is reversed.
1:0	UOC[1:0]	00	R/W	U-phase conduction control setting The port output is controlled by the combination of this bit, <UOC>, <UPWM>, [PMDxMDPOT]<POLH>/<POLL>, and [PMDxMDCR]<SYNTMD>. (Refer to Table 3.3.) When <UOC>=00, U-phase carrier wave is reversed.

Note 1: The byte write (upper 8 bits ([15:8]) and lower 8 bits ([7:0]) are written separately) should not be done. When the byte write is done, the operation cannot be guaranteed.

Note 2: The conduction control register can be updated while the PWM counter is operating, because it has a triple-buffer structure.

Note 3: The update timing of the execution buffer is selected [PMDxMDPOT]<PSYNCS>.

Note 4: For the update timing of the intermediate buffer, refer to "3.7 Buffer Operation".

Note 5: When this register is read, the value of the register stage (the data set through the bus) returns.

4.2.11. [PMDxEMGCR] (EMG control register)

Bit	Bit Symbol	After Reset	Type	Description
31:16	-	0	R	Read as "0"
15:13	-	000	R/W	Write as "000"
12:8	EMGCNT[4:0]	00000	R/W	EMG input detection time (Note1) 00000 to 11111 (When "00000" is set, the noise filter is bypassed.) The noise reduction time is set for detected abnormal input signal. The noise reduction time is calculated with the following formula: <EMGCNT> × 16/fsys
7	EMGIPOL	0	R/W	EMGx pin polarity selection (Note1) 0: Low active. 1: High active
6	-	0	R	Read as "0"
5	INHEN	1	R/W	PMD enable or disable in Debug halt 0: Disabled. 1: Enabled (Initial state). When debug halt signal is input, this bit selects either to stop PMD, or not.
4:3	EMGMD[1:0]	11	R/W	EMG protection mode selection (Note2) 00: All phase High-impedance 01: All upper-phase ON/All lower-phase High-impedance 10: All upper-phase High-impedance/All lower-phase ON 11: All phase High-impedance Note: ON: PWM output continues. This field sets the port outputs of the upper phases (UOx, VOx, and WOx) and the lower phases (XOx, YOx, and ZOx).
2	EMGISEL	0	R/W	EMGx pin input disable 0: Port input is enabled. 1: Port input is disabled. EMGx pin input signal is disabled to input the protection control circuit.
1	EMGRS	0	W	Return from EMG protection state 0: Don't care 1: Return from the protection state [PMDxMDOUT] register should be set to "0x000". Then, [PMDxEMGSTA]<EMGI> becomes "1". If <EMGRS> is set to "1", the device exits EMG protection state. Read as "0".
0	EMGEN	1	R/W	EMG protection control circuit enable or disable setting 0: Disabled. 1: Enabled (Initial state) When EMG protection control circuit is disabled, EMG release register [PMDxEMGREL] should be set to "0x5A" and "0xA5" in order, then <EMGEN> should be set to "0". (3 instructions should be executed continuously.)

Note 1: If <EMGCNT> and <EMGIPOL> is changed while EMG protection control circuit is enabled, it may become the protection state. Therefore, when these are changed, please return from the EMG protected state by the following procedure.

- (1) [PMDxEMGSTA]<EMGI> should be read to confirm its value is "1".
- (2) [PMDxMDOUT]<UPWM>, <VPWM>, <WPWM>, <UOC>, <VOC>, and <WOC> should be set to "0" to set all port outputs to inactive state.
- (3) [PMDxEMGCR]<EMGRS> should be set to "1" to exit EMG protection.

Note 2: <EMGMD> protection mode setting is prioritized when OVV and EMG occur at the same time.

4.2.12. [PMDxEMGSTA] (EMG status register)

Bit	Bit Symbol	After Reset	Type	Description
31:2	-	0	R	Read as "0"
1	EMGI	Undefined.	R	EMG input state 0: Active input. 1: Inactive input. When an active signal among the enabled EMG input signals is input, this bit is set to "0".
0	EMGST	0	R	EMG protection state 0: Normal operation 1: Protection state EMG protection status can be checked by reading this bit.

4.2.13. [PMDxEMGREL] (EMG release register)

Bit	Bit Symbol	After Reset	Type	Description
31:8	-	0	R	Read as "0"
7:0	EMGREL[7:0]	0x00	W	EMG/OVV disable code The setting of "0x5A" and "0xA5" in order disables EMG function or OVV function. After the disable code is written, [PMDxEMGCR]<EMGEN>=0 or [PMDxOVVCR]<OVVEN>=0 should be set continuously.

Note: The disable code should be written for EMG function and OVV function separately.

4.2.14. [PMDxOVVCR] (OVV control register)

Bit	Bit Symbol	After Reset	Type	Description
31:16	-	0	R	Read as "0"
15	OVVRSMD	0	RW	OVV exit operation selection 0: Automatic return from the protection state or return by the setting of <OVVRS>=1. The automatic return timing is synchronous with U-phase PWM carrier after OVV input becomes inactive. 1: Return from the protection state by the setting of <OVVRS>=1.
14:13	-	0	R	Read as "0"
12:8	OVVCNT[4:0]	00000	RW	OVV input detection time 00001 to 11111 (When "00000" is set, the stored data becomes "00001".) The noise reduction time for OVV input is set. The noise reduction time is calculated with the following formula: <OVVCNT> × 16/fsys Please set with OVV disabled state (<OVVEN>=0).
7	OVVIPOL	0	RW	OVVx pin polarity selection 0: Low active. 1: High active.
6:5	-	00	RW	Write as "00"
4:3	OVVMD[1:0]	00	RW	OVV protection mode selection (Note) 00: No output restrictions. 01: All upper-phase ON/All lower-phase OFF 10: All upper-phase OFF/All lower-phase ON 11: All phase OFF This field sets the upper-phase (UOx, VOx, and WOx) and the lower-phase (XOx, VOx, and ZOx) outputs to ON or OFF when OVV occurs. ON means the fixed active output, and OFF, the fixed inactive output. Active or Inactive is set to [PMDxMDPOT]<POLL> and <POLH>.
2	OVVISEL	0	RW	OVVx input selection 0: Port input enabled. 1: Port input disabled. OVV signal input to the protection control circuit is disabled to input from the port.
1	OVVRS	0	W	Return from OVV protection state 0: Don't care 1: Return from the protection state Read as "0". The return should be done after confirming that [PMDxOVVSTA]<OVVI> becomes "1".
0	OVVEN	0	RW	OVV protection control circuit enable or disable 0: Disabled. 1: Enabled. When OVV protection control circuit is disabled, EMG release register [PMDxEMGREL] should be set to "0x5A" and "0xA5" in order, then <OVVEN> should be set to "0". (3 instructions should be executed continuously.)

Note: [PMDxEMGCR]<EMGMD> protection mode setting is prioritized when OVV and EMG occur at the same time.

4.2.15. [PMDxOVVSTA] (OVV status register)

Bit	Bit Symbol	After Reset	Type	Description
31:2	-	0	R	Read as "0"
1	OVVI	Undefined.	R	OVV input state 0: Active input. 1: Inactive input. When an active signal among the enabled OVV input signals is input, this bit is set to "0".
0	OVVST	0	R	OVV protection state 0: Normal operation 1: Protection state OVV protection status can be checked by reading this bit.

4.2.16. [PMDxDTR] (Dead time register)

Bit	Bit Symbol	After Reset	Type	Description
31:10	-	0	R	Read as "0"
9:0	DTR[9:0]	0x000	R/W	Dead time is set. 0x000 to 0x3FF The dead time is calculated with the following formula: <DTR> setting value × 4/fsys

Note: This register should be set during [PMDxMDEN]<PWMEN>=0.

4.2.17. Trigger comparison register

4.2.17.1. [PMDxTRGCMP0] (Trigger comparison 0 register)

Bit	Bit Symbol	After Reset	Type	Description
31:15	-	0	R	Read as "0"
14:0	TRGCMP0[14:0]	0x0000	R/W	Trigger output comparison register Setting range: 0x0000 to 0x7FFF This register value is compared with the basic carrier or U-phase carrier to generate a trigger signal (PMDxTRG0).

Note 1: The byte write (upper 8 bits ([15:8]) and lower 8 bits ([7:0]) are written separately) should not be done. When the byte write is done, the operation cannot be guaranteed.

Note 2: The trigger comparison register can be updated while the PWM counter is operating, because it has a triple-buffer structure.

Note 3: For the update timing of the execution buffer, refer to "Table 3.4 Buffer update timing of Trigger comparison register".

Note 4: For the update timing of the intermediate buffer, refer to "3.7 Buffer Operation".

Note 5: When this field is read, the value of the register stage (the data set through the bus) returns.

4.2.17.2. [PMDxTRGCMP1] (Trigger comparison 1 register)

Bit	Bit Symbol	After Reset	Type	Description
31:15	-	0	R	Read as "0"
14:0	TRGCMP1[14:0]	0x0000	R/W	Trigger output comparison register Setting range: 0x0000 to 0x7FFF This register value is compared with the basic carrier or U-phase carrier to generate a trigger signal (PMDxTRG1).

Note 1: The byte write (upper 8 bits ([15:8]) and lower 8 bits ([7:0]) are written separately) should not be done. When the byte write is done, the operation cannot be guaranteed.

Note 2: The trigger comparison register can be updated while the PWM counter is operating, because it has a triple-buffer structure.

Note 3: For the update timing of the execution buffer, refer to "Table 3.4 Buffer update timing of Trigger comparison register".

Note 4: For the update timing of the intermediate buffer, refer to "3.7 Buffer Operation".

Note 5: When this field is read, the value of the register stage (the data set through the bus) returns.

4.2.17.3. [PMDxTRGCMP2] (Trigger comparison 2 register)

Bit	Bit Symbol	After Reset	Type	Description
31:15	-	0	R	Read as "0"
14:0	TRGCMP2[14:0]	0x0000	R/W	Trigger output comparison register Setting range: 0x0000 to 0x7FFF This register value is compared with the basic carrier or V-phase carrier to generate a trigger signal (PMDxTRG2).

Note 1: The byte write (upper 8 bits ([15:8]) and lower 8 bits ([7:0]) are written separately) should not be done. When the byte write is done, the operation cannot be guaranteed.

Note 2: The trigger comparison register can be updated while the PWM counter is operating, because it has a triple-buffer structure.

Note 3: For the update timing of the execution buffer, refer to "Table 3.4 Buffer update timing of Trigger comparison register".

Note 4: For the update timing of the intermediate buffer, refer to "3.7 Buffer Operation".

Note 5: When this field is read, the value of the register stage (the data set through the bus) returns.

4.2.17.4. [PMDxTRGCMP3] (Trigger comparison 3 register)

Bit	Bit Symbol	After Reset	Type	Description
31:15	-	0	R	Read as "0"
14:0	TRGCMP3[14:0]	0x0000	R/W	Trigger output comparison register Setting range: 0x0000 to 0x7FFF This register value is compared with the basic carrier or W-phase carrier to generate a trigger signal (PMDxTRG3).

Note 1: The byte write (upper 8 bits ([15:8]) and lower 8 bits ([7:0]) are written separately) should not be done. When the byte write is done, the operation cannot be guaranteed.

Note 2: The trigger comparison register can be updated while the PWM counter is operating, because it has a triple-buffer structure.

Note 3: For the update timing of the execution buffer, refer to "Table 3.4 Buffer update timing of Trigger comparison register".

Note 4: For the update timing of the intermediate buffer, refer to "3.7 Buffer Operation".

Note 5: When this field is read, the value of the register stage (the data set through the bus) returns.

4.2.18. [PMDxTRGCR] (Trigger control register)

Bit	Bit Symbol	After Reset	Type	Description
31:17	-	0	R	Read as "0"
16	CARSEL	0	RW	Comparison carrier selection 0: Comparison with the base carrier [PMDxTRGCMP0] to [PMDxTRGCMP3] are compared with the basic carrier. 1: Comparison with each phase carrier [PMDxTRGCMP0] and [PMDxTRGCMP1] are compared with U-phase carrier. [PMDxTRGCMP2] is compared with V-phase carrier. [PMDxTRGCMP3] is compared with W-phase carrier.
15	TRG3BE	0	RW	Asynchronous update enable of the execution buffer in [PMDxTRGCMP3] (Note1) 0: Synchronous update (Note2) 1: Asynchronous update (the update is done immediately after the data write.)
14:12	TRG3MD[2:0]	000	RW	[PMDxTRGCMP3] mode setting This field selects the coincidence mode of the trigger output. (Note3) 000: Trigger output is disabled. 001: Trigger is output at the coincidence in the first half of the triangular carrier. 010: Trigger is output at the coincidence in the second half of the triangular carrier. 011: Trigger is output at the coincidence in the first and second halves of the triangular carrier. 100: Trigger is output at PWM end timing. 101: Trigger is output at PWM center timing. 110: Trigger is output at PWM end and center timings. 111: Trigger output is disabled.
11	TRG2BE	0	RW	Asynchronous update enable for the execution buffer in [PMDxTRGCMP2] (Note1) 0: Synchronous update (Note2) 1: Asynchronous update (the update is done immediately after the data write.)
10:8	TRG2MD[2:0]	000	RW	[PMDxTRGCMP2] mode setting This field selects the coincidence mode of the trigger output. (Note3) 000: Trigger output is disabled. 001: Trigger is output at the coincidence in the first half of the triangular carrier. 010: Trigger is output at the coincidence in the second half of the triangular carrier. 011: Trigger is output at the coincidence in the first and second halves of the triangular carrier. 100: Trigger is output at PWM end timing. 101: Trigger is output at PWM center timing. 110: Trigger is output at PWM end and center timings. 111: Trigger output is disabled.
7	TRG1BE	0	RW	Asynchronous update enable for the execution buffer in [PMDxTRGCMP1] (Note1) 0: Synchronous update (Note2) 1: Asynchronous update (the update is done immediately after the data write.)

Bit	Bit Symbol	After Reset	Type	Description
6:4	TRG1MD[2:0]	000	R/W	<p>[PMDxTRGCMP1] mode setting</p> <p>This field selects the coincidence mode of the trigger output. (Note3)</p> <p>000: Trigger output is disabled.</p> <p>001: Trigger is output at the coincidence in the first half of the triangular carrier.</p> <p>010: Trigger is output at the coincidence in the second half of the triangular carrier.</p> <p>011: Trigger is output at the coincidence in the first and second halves of the triangular carrier.</p> <p>100: Trigger is output at PWM end timing.</p> <p>101: Trigger is output at PWM center timing.</p> <p>110: Trigger is output at PWM end and center timings.</p> <p>111: Trigger output is disabled.</p>
3	TRG0BE	0	R/W	<p>Asynchronous update enable for the execution buffer in [PMDxTRGCMP0] (Note1)</p> <p>0: Synchronous update (Note2)</p> <p>1: Asynchronous update (the update is done immediately after the data write.)</p>
2:0	TRG0MD[2:0]	000	R/W	<p>[PMDxTRGCMP0] mode setting</p> <p>This field selects the coincidence mode of the trigger output. (Note3)</p> <p>000: Trigger output is disabled.</p> <p>001: Trigger is output at the coincidence in the first half of the triangular carrier.</p> <p>010: Trigger is output at the coincidence in the second half of the triangular carrier.</p> <p>011: Trigger is output at the coincidence in the first and second halves of the triangular carrier.</p> <p>100: Trigger is output at PWM end timing.</p> <p>101: Trigger is output at PWM center timing.</p> <p>110: Trigger is output at PWM end and center timings.</p> <p>111: Trigger output is disabled.</p>

Note 1: When $[PMDxMDEN] < PWMEN > = 0$, the asynchronous update is done regardless of the setting.

Note 2: For the update timing, refer to "Table 3.4 Buffer update timing of Trigger comparison register".

Note 3: When $[PMDxMDCR] < UPWMMD > / < VPWMMD > / < WPWMMD > = 00, 10$ (Saw-tooth wave);

- There is no distinction between the first half and the second half, regardless of the setting value, "001", "010", or "011".
- Trigger does not occur at the PWM center. Either "100", "101", or "110" is selected, it occurs output at the PWM end.

4.2.19. **[PMDxTRGSYNCR]** (Trigger update timing setting register)

Bit	Bit Symbol	After Reset	Type	Description
31:2	-	0	R	Read as "0"
1:0	TSYNCS[1:0]	00	R/W	<p>Update timing setting for the execution buffer in the trigger comparison register</p> <p>00: Each phase PWM end or center timing selected by $[PMDxTRGCR] < TRGnMD >$ (n= 0 to 3).</p> <p>01: Each phase PWM center timing</p> <p>10: Each phase PWM end timing</p> <p>11: Each phase PWM end and center timings</p>

Note 1: For the update timing, refer to "Table 3.4 Buffer update timing of Trigger comparison register".

Note 2: When $[PMDxMDEN] < PWMEN > = 0$, the asynchronous update is done regardless of the setting.

4.2.20. [PMDxTRGMD] (Trigger output mode setting register)

Bit	Bit Symbol	After Reset	Type	Description
31:2	-	0	R	Read as "0"
1	-	0	R/W	Write as "0"
0	EMGTGE	0	R/W	Output enable setting in EMG protection state 0: Trigger output is disabled during the protection state. 1: Trigger output is enabled during the protection state. This bit selects enable or disable of the trigger output during EMG protection state.

4.2.21. [PMDxMBUFCR] (Intermediate buffer control register)

Bit	Bit Symbol	After Reset	Type	Description
31:3	-	0	R	Read as "0"
2:0	BUFCR[2:0]	000	R/W	Intermediate buffer update control 000: Intermediate buffer is disabled (the buffer is bypassed). 001: PWM period update (U-phase PWM end timing) 010: PWM period update (U-phase PWM center timing) 011: PWM period update (U-phase PWM 3/4 timing) 100: PWM period update (U-phase PWM 1/4 timing) 101: PWM half period update (U-phase PWM end and center timings) 110: PWM half period update (U-phase PWM 1/4 and 3/4 timings) 111: Reserved

Note: When PMD disable ([PMDxMDEN]<PWMEN>=0) and in EMG protection state, the update timing is an asynchronous one regardless of the setting.

5. Precaution for Use

- When PMD cooperate with ADC, please refer to "12-bit Analog to Digital Converter" of the reference manual together.
- The byte write of registers is disabled regardless of whether PWM is operating or stopped.
- *[PMDxBCARI]* value has changed during PWM operation. Therefore, the byte read of *[PMDxBCARI]* should not be done. Read should be done with Word or Half-word unit.
- The following registers have the double-buffer or triple-buffer structure. The data written to these registers is transferred to the subsequent stage buffer at each update timing (depending on the setting).
 - *[PMDxCMPU]*, *[PMDxCMPV]*, *[PMDxCMPW]*
 - *[PMDxMDOU]*
 - *[PMDxRATE]*
 - *[PMDxMDCR]*<UPWMMD>, <VPWMMD>, <WPWMMD>
 - *[PMDxTRGCMP0]* to *[PMDxTRGCMP3]*
- Be sure to release processing from the EMG protection state before using the PMD.
- The EMG protection control circuit is enabled after reset. If it is not used, prohibit it with the following procedure.
 - (1) *[PMDxEMGREL]* should be set to "0x5A"
 - (2) *[PMDxEMGREL]* should be set to "0xA5"
 - (3) *[PMDxEMGCR]*<EMGEN> should be set to "0"

Note: These 3 instructions must be executed consecutively.

- When attempting to stop supplying the clock, make sure to check whether the PMD is stopping. Note that when the MCU enters STOP1/STOP2 mode, make sure to check whether the PMD is stopping as well.

6. Revision History

Table 6.1 Revision history

Revision	Date	Description
1.0	2018-01-16	First release
2.0	2018-06-28	<ul style="list-style-type: none"> - The entire document dead-time→dead time - Related document Arrange documents - 3.1.Clock Supply Modified register name - Figure 3.1 <nPWMMMD>→nPWMMMD,<nOC>→nOC - Figure 3.5 <UPWMMMD><VPWMMMD><WPWMMMD>→ <UPWMMMD><VPWMMMD><WPWMMMD> Execution buffer - 3.3. Conduction Control Circuit Figure 3.7: <EMGST>→ [PMDxEMGSTA]<EMGST> Deleted "Timing signals of each phase" 2nd line: [PMDxMDOUT] register → [PMDxMDOUT] - 3.4.1.EMG Protection Control Circuit 1st term: Deleted ", respectively" 3rd term: title "Return of the EMG"→"Return from the EMG" EMG pin → EMGx pin 4th term: "and "0xA5" in order. then" → "and "0xA5" in order, then" - 3.4.2.OVV Protection Control Circuit 1st term: Deleted ", respectively" 4th term: "and "0xA5" in order. Then" → "and "0xA5" in order, then" - Figure 3.11 output polarity change → output polarity change circuit - 3.6. Synchronous Trigger Generation Circuit Figure 3.14 <UOC>→UOC, <VOC>→VOC, <WOC>→WOC Table 3.4 Note3: x→xxx - 3.7. Buffer Operation 5th line: single buffer → single-buffer 8th line: "If <BUFCTR>=000 is set," → "When <BUFCTR>=000," - 3.8. Decimation of Execution Buffer... Changed in 3rd line: synchronous trigger → ADC synchronous trigger Deleted in 4th line: " is set" - 4.1. List of Registers Table of Base Address: Deleted "Function Name" cell Added TYPE3 column - 4.2.2. Description: Tool break→debug halt - 4.2.3. DCMEN/Description: Deleted "Note: " [PMDxCMPn] → [PMDxCMPU]/[PMDxCMPV]/[PMDxCMPW] [PMDxTRGCMPn] → [PMDxTRGCMP0]/[PMDxTRGCMP1]/[PMDxTRGCMP2]/[PMDxTRGCMP3] <nPWMMMD>→ <UPWMMMD>/<VPWMMMD>/<WPWMMMD> SYNTMD/Description: <nOC>→<UOC>/<VOC>/<WOC> <nPWM>→<UPWM>/<VPWM>/<WPWM> DTYMD/Description: CMPU→[PMDxCMPU], CMPV→[PMDxCMPV], CMPW→[PMDxCMPW] - 4.2.11. EMGCNT/Description: Changed hexadecimal notation to binary notation EMGIPOL/Description: Deleted "Please set with EMG disabled state.... " EMGISEL/Description: protection circuit →protection control circuit

Revision	Date	Description
		- 4.2.14. OVVCNT/Description: Changed hexadecimal notation to binary notation OVVISEL/Description: protection circuit → protection control circuit - 4.2.18. Note1: Deleted " is set" - 4.2.19. Note1: "For update timing" → "For the update timing" - 5. Precaution for Use 1st term: "with a ADC," → "with ADC," Last term: STOP→STOP1/STOP2

RESTRICTIONS ON PRODUCT USE

Toshiba Corporation and its subsidiaries and affiliates are collectively referred to as "TOSHIBA". Hardware, software and systems described in this document are collectively referred to as "Product".

- TOSHIBA reserves the right to make changes to the information in this document and related Product without notice.
- This document and any information herein may not be reproduced without prior written permission from TOSHIBA. Even with TOSHIBA's written permission, reproduction is permissible only if reproduction is without alteration/omission.
- Though TOSHIBA works continually to improve Product's quality and reliability, Product can malfunction or fail. Customers are responsible for complying with safety standards and for providing adequate designs and safeguards for their hardware, software and systems which minimize risk and avoid situations in which a malfunction or failure of Product could cause loss of human life, bodily injury or damage to property, including data loss or corruption. Before customers use the Product, create designs including the Product, or incorporate the Product into their own applications, customers must also refer to and comply with (a) the latest versions of all relevant TOSHIBA information, including without limitation, this document, the specifications, the data sheets and application notes for Product and the precautions and conditions set forth in the "TOSHIBA Semiconductor Reliability Handbook" and (b) the instructions for the application with which the Product will be used with or for. Customers are solely responsible for all aspects of their own product design or applications, including but not limited to (a) determining the appropriateness of the use of this Product in such design or applications; (b) evaluating and determining the applicability of any information contained in this document, or in charts, diagrams, programs, algorithms, sample application circuits, or any other referenced documents; and (c) validating all operating parameters for such designs and applications. **TOSHIBA ASSUMES NO LIABILITY FOR CUSTOMERS' PRODUCT DESIGN OR APPLICATIONS.**
- **PRODUCT IS NEITHER INTENDED NOR WARRANTED FOR USE IN EQUIPMENTS OR SYSTEMS THAT REQUIRE EXTRAORDINARILY HIGH LEVELS OF QUALITY AND/OR RELIABILITY, AND/OR A MALFUNCTION OR FAILURE OF WHICH MAY CAUSE LOSS OF HUMAN LIFE, BODILY INJURY, SERIOUS PROPERTY DAMAGE AND/OR SERIOUS PUBLIC IMPACT ("UNINTENDED USE").** Except for specific applications as expressly stated in this document, Unintended Use includes, without limitation, equipment used in nuclear facilities, equipment used in the aerospace industry, medical equipment, equipment used for automobiles, trains, ships and other transportation, traffic signaling equipment, equipment used to control combustions or explosions, safety devices, elevators and escalators, devices related to electric power, and equipment used in finance-related fields. **IF YOU USE PRODUCT FOR UNINTENDED USE, TOSHIBA ASSUMES NO LIABILITY FOR PRODUCT.** For details, please contact your TOSHIBA sales representative.
- Do not disassemble, analyze, reverse-engineer, alter, modify, translate or copy Product, whether in whole or in part.
- Product shall not be used for or incorporated into any products or systems whose manufacture, use, or sale is prohibited under any applicable laws or regulations.
- The information contained herein is presented only as guidance for Product use. No responsibility is assumed by TOSHIBA for any infringement of patents or any other intellectual property rights of third parties that may result from the use of Product. No license to any intellectual property right is granted by this document, whether express or implied, by estoppel or otherwise.
- **ABSENT A WRITTEN SIGNED AGREEMENT, EXCEPT AS PROVIDED IN THE RELEVANT TERMS AND CONDITIONS OF SALE FOR PRODUCT, AND TO THE MAXIMUM EXTENT ALLOWABLE BY LAW, TOSHIBA (1) ASSUMES NO LIABILITY WHATSOEVER, INCLUDING WITHOUT LIMITATION, INDIRECT, CONSEQUENTIAL, SPECIAL, OR INCIDENTAL DAMAGES OR LOSS, INCLUDING WITHOUT LIMITATION, LOSS OF PROFITS, LOSS OF OPPORTUNITIES, BUSINESS INTERRUPTION AND LOSS OF DATA, AND (2) DISCLAIMS ANY AND ALL EXPRESS OR IMPLIED WARRANTIES AND CONDITIONS RELATED TO SALE, USE OF PRODUCT, OR INFORMATION, INCLUDING WARRANTIES OR CONDITIONS OF MERCHANTABILITY, FITNESS FOR A PARTICULAR PURPOSE, ACCURACY OF INFORMATION, OR NONINFRINGEMENT.**
- Do not use or otherwise make available Product or related software or technology for any military purposes, including without limitation, for the design, development, use, stockpiling or manufacturing of nuclear, chemical, or biological weapons or missile technology products (mass destruction weapons). Product and related software and technology may be controlled under the applicable export laws and regulations including, without limitation, the Japanese Foreign Exchange and Foreign Trade Law and the U.S. Export Administration Regulations. Export and re-export of Product or related software or technology are strictly prohibited except in compliance with all applicable export laws and regulations.
- Please contact your TOSHIBA sales representative for details as to environmental matters such as the RoHS compatibility of Product. Please use Product in compliance with all applicable laws and regulations that regulate the inclusion or use of controlled substances, including without limitation, the EU RoHS Directive. **TOSHIBA ASSUMES NO LIABILITY FOR DAMAGES OR LOSSES OCCURRING AS A RESULT OF NONCOMPLIANCE WITH APPLICABLE LAWS AND REGULATIONS.**