

TC78H651FNG

Usage considerations

This document should be used as a reference manual for understanding the usage considerations of TC78H651FNG. Since the electrical characteristics and other rating values may be changed, refer to the latest technical datasheet of this product.

Outline of this product

Part number	TC78H651FNG	
Basic function	Dual bridge driver	Two brushed DC motors or one stepping motor is controlled.
Absolute maximum ratings	7.0V / 1.6A (each channel)	High drive capability
Operating voltage	$V_M=1.8$ to 6.0V	Low voltage drive
Output propagation delay time	$t_{pLH}=90$ ns (typ.) $t_{pHL}=90$ ns (typ.)	High-speed operation
Standby function	Available	Current consumption 0 μ A (typ.)
PWM drive	Direct PWM	
Package	P-TSSOP16-0505-0.65-001	
Error detection	· Thermal shutdown · Over current detection · Under voltage lockout	

Contents

1.	Outline	3
1.1	Brushed DC motor.....	3
1.2	Formation of dedicated control / drive IC	3
1.3	Features of TC78H651FNG.....	3
2.	Basic operation of H-Bridge circuit.....	4
3.	Power supply voltage.....	5
3.1	Power supply voltage and usage range	5
3.2	Power supply sequence	5
4.	Output power	5
5.	Control input	5
6.	Power consumption of IC.....	6
7.	Application circuit example.....	8
8.	I/O function	9
9.	Output switching characteristics.....	10
10.	Error detection circuit.....	11
11.	Drive of bipolar stepping motor	12
12.	Reference land pattern example	13
13.	Evaluation board (Example of our original board)	14
14.	Operation waveform of motor drive (reference).....	16
15.	H-Bridge driver series product supporting low power supply voltage drive	18
	Notes on Contents	19
	IC Usage Considerations	19
	RESTRICTIONS ON PRODUCT USE	21

1. Outline

1.1 Brushed DC motor

Brushed DC motor has a mechanical contact called a brush (commutator) as its name. There are some drawbacks such as its life and radiation noise from the contact. However, The control/drive circuit can be simplified because the rotation direction can be easily controlled by the power supply polarity and the rotation speed can be easily controlled by the power supply voltage. One transistor element can be used for unidirectional rotation, and four transistor elements (H-Bridge circuits) can be used for bidirectional rotation, which is a great advantage.

1.2 Formation of dedicated control / drive IC

The TC78H651FNG is an IC for controlling and driving brushed DC motors. This IC integrates two H-Bridge circuits (two channels). Two brushed DC motors can be controlled and driven. It is also possible to control and drive one stepping motor.

By formation of an IC, the dead time is automatically set to prevent through current in H-Bridge circuit when the high-side and low-side elements are turned on simultaneously. That has been difficult to realize for the drive circuit which has conventional discrete components. which has been difficult to realize for the drive circuit configured with conventional discrete components. Additionally, this IC includes various error detection functions such as thermal shut down (TSD), over current detection (ISD), and under voltage lockout (UVLO) to protect the IC.

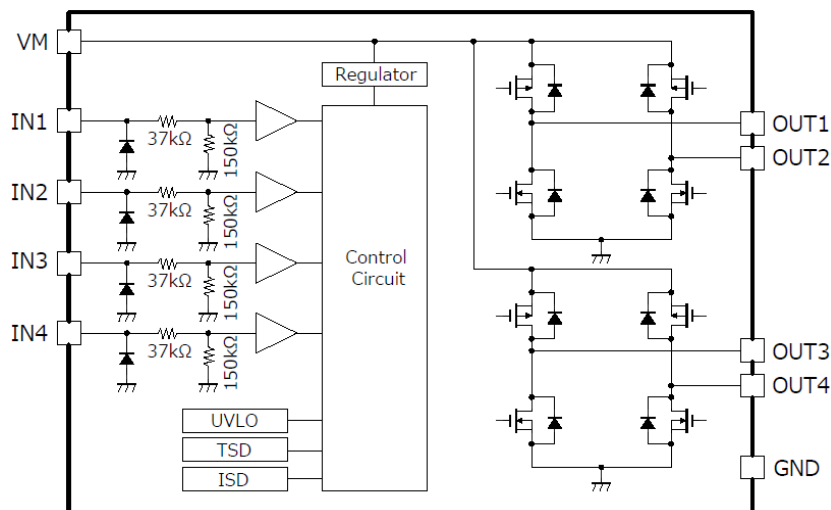

1.3 Features of TC78H651FNG

(1) Low voltage operation:

It can operate with the rating of 1.8V to 6.0 V. Therefore, this product is suitable for motor control of battery-powered devices.

(2) Drive current:

The TC78H651FNG integrates two H-Bridge circuits (2 channels). The MOSFETs which configure with H-Bridge circuit use DMOS elements with low-on resistance. Thereby, the motor drive capability (drive current) is higher than conventional equivalent products.

<Maximum absolute ratings (our comparison)>

Conventional TC78H611FNG: $I_{out}=1.1A$ → New TC78H651FNG: $I_{out}=1.6A$

(3) High-speed drive (High-speed following up to PWM signal):

The dead time is set internally short, and high-speed operation followed up to PWM signal ($f_{PWM}=500$ kHz) is possible.

(4) Reduction of Standby current:

The standby current is reduced greatly because all circuits in the IC configure with CMOS / DMOS elements. The current consumption in standby mode is 0 μA (typ.).

2. Basic operation of H-Bridge circuit

The H-Bridge circuit is used for a brushed DC motor, and it controls the direction of rotation (forward rotation / reverse rotation). The H-Bridge circuit has H-shape configuration of MOSFET. Therefore, it is called H-Bridge. The H-Bridge circuit makes a brushed DC motor rotate by turning on with "crossed" the upper and lower of drive elements. By turning on with the reverse "crossed", the current flows to the motor in reverse. Then, the motor rotates in reverse.

The TC78H651FTG integrates two H-Bridge circuits (2 channels). The MOSFETs which configure with H-Bridge circuit use DMOS elements with low-on resistance. Thereby, the motor drive capability (drive current) is higher than conventional equivalent products.

The MOSFETs to be turned on are switched by the logic level which is input to the control input pins (IN1, IN2, etc.). Thereby, H-Bridge circuit can control the motor rotation directions (forward, reverse, and stop).

- (1) Stop (motor free) operation (IN1=L, IN2=L)
All MOSFETs are in the OFF states. Since the current does not flow to the motor coil, the motor is in the stop (free) state.
- (2) Forward rotation (IN1=H, IN2=L)
The high-side MOSFET which connects to the OUT1 pin and the low-side MOSFET which connects to the OUT2 pin are turned ON. Then, the current flows to the motor coil and the motor rotates.
- (3) Reverse rotation (IN1=L, IN2=H)
The low-side MOSFET which connects to the OUT1 pin and the high-side MOSFET which connects to the OUT2 pin are turned ON. Then the current flows to the motor coil in reverse direction with case (2), the motor rotates in reverse.

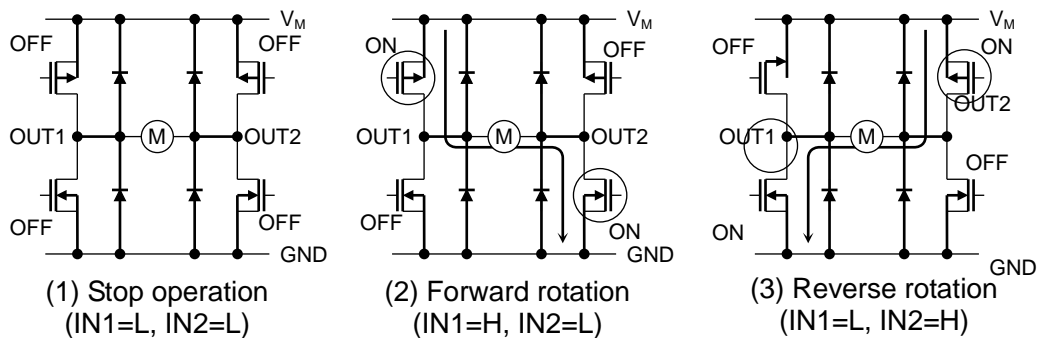

Figure 2.1 Operation of H-Bridge circuit

3. Power supply voltage

3.1 Power supply voltage and usage range

In using the TC78H651FNG, the voltage should be applied to the VM pin. The maximum rating of VM supply voltage is 7.0 V. Usage range of the power supply is 1.8 to 6.0 V. The VM operation range is up to 1.8V. This IC is suitable for battery-powered applications. A regulator is embedded for internal logic power supply, and the IC operates with only applying voltage to VM pin.

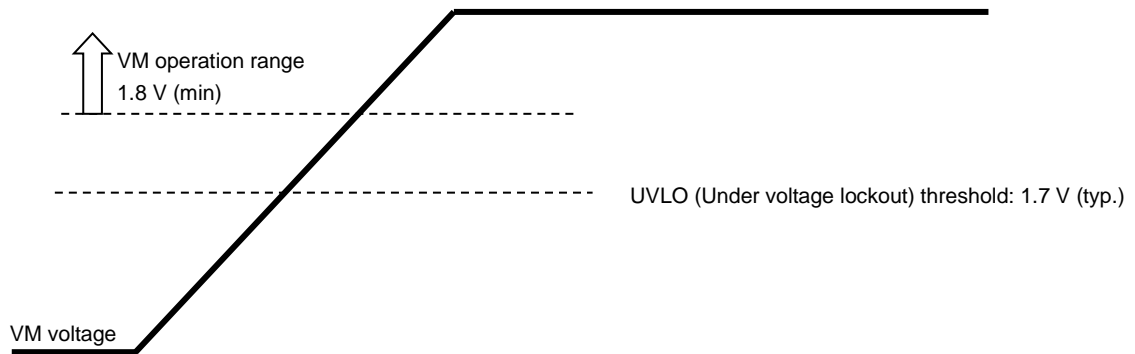

Figure 3.1 VM operation range and UVLO threshold

3.2 Power supply sequence

This IC realizes the single power supply drive by the internal regulator. Therefore, special procedures are not required between different power supplies when power supply is turned on or off. Additionally, the under voltage lockout (UVLO) is embedded to prevent a malfunction at low voltage.

However, under the unstable state of inputting the power supply (transient area) and shutdown, it is recommended to turn off the motor operation. Please operate the motor by switching the input signal after the power supply becomes in the stable state.

4. Output power

Please configure the motor current 1.5 A or less. Also, note that the peak current may be limited due to usage conditions (supply voltage, ambient temperature, PCB layout pattern, heat issue, step resolution setting, etc.). Please evaluate and check if the device can operate at the required conditions.

5. Control input

The IC can avoid malfunction occurred by the electromotive force, which generates when the control logic signal is input without VM voltage.

However, it is recommended to set the control logic signal low level while VM is not supplied.

6. Power consumption of IC

The power consumption is mainly consumed by the output stage MOSFET and the control block.

$$P_D (\text{total}) = P_D (\text{out}) + P_D (\text{bias})$$

- **Power consumption of the output block MOSFET**

The power consumption of the output block ($P_D (\text{out})$) is calculated from following formula.

$$P_D (\text{out}) = \text{Number of driving H-Bridge} \times I_{\text{OUT}} (\text{A}) \times I_{\text{OUT}} (\text{A}) \times R_{\text{ON}} (\Omega)$$

In case of driving a stepping motor, $V_M=3.0\text{V}$, $R_{\text{ON}} = 0.26 \Omega$, and $I_{\text{OUT}} = 0.2 \text{ A}$, following equation is gained.

$$P_D (\text{out}) = 2 (\text{ch}) \times 0.2 (\text{A}) \times 0.2 (\text{A}) \times 0.26 (\Omega) = 0.0208 (\text{W})$$

* R_{ON} : On-resistance (Upper + lower) of MOSFET to configure the H-Bridge circuit

Please keep in mind that this value has the characteristic depending on power supply voltage and temperature although it is defined as 0.26Ω in the above-mentioned formula. Please refer to the following graph about the temperature characteristics of R_{ON} .

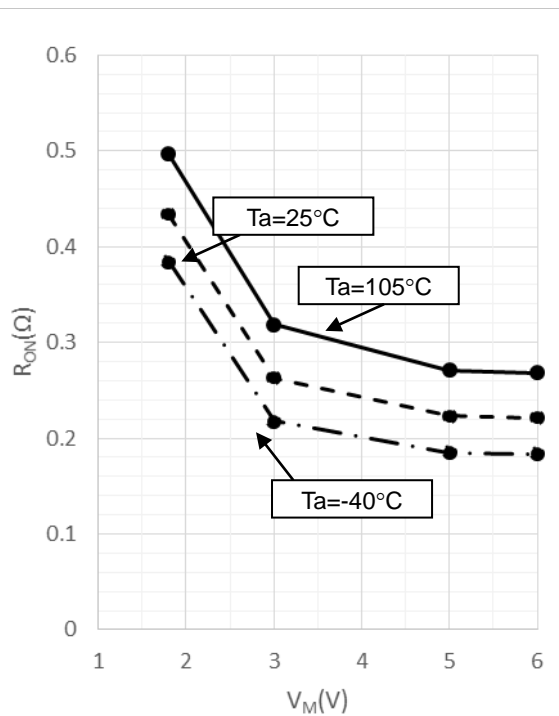

Figure 6.1 RON characteristics (IOUT = 0.5A)

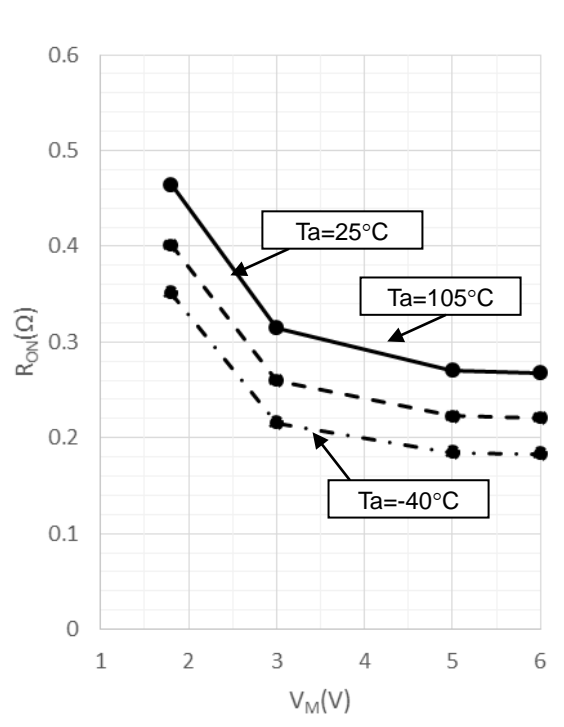

Figure 6.2 RON characteristics (IOUT=0.2A)

*The values shown in the above graphs are reference, not design values.

- **Power consumption of the control block**

The power consumption of the control block (P_D (bias)) is calculated from following formula.

$$P_D (\text{bias}) = V_M (\text{V}) \times I_M (\text{A})$$

When $V_M = 3.0 \text{ V}$, following equation is gained.

$$P_D (\text{bias}) = 3.0 (\text{V}) \times 0.0006 (\text{A}) = 0.0018 (\text{W})$$

* I_M : Consumption current of IC

Please keep in mind that this value has the characteristic depending on power supply voltage and temperature although it is defined as 0.0006A in the above-mentioned formula. Please refer to the following graph about the temperature characteristics of I_M .

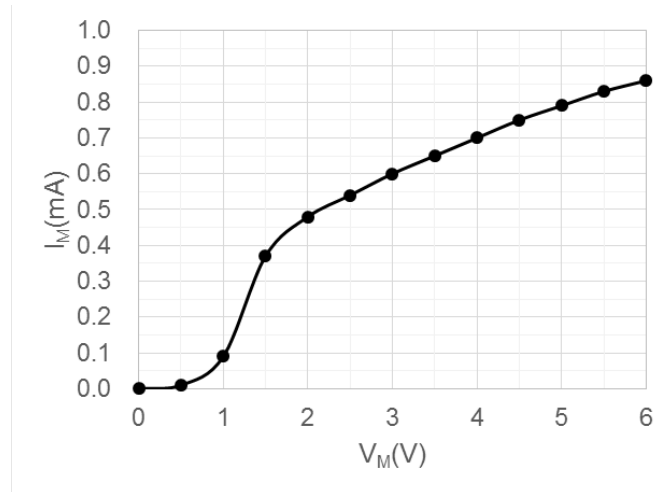

Figure 6.3 I_M characteristics (IN1=IN2=IN3=IN4=H in conditions)

*The values shown in the above graphs are reference, not design values.

Total power consumption (P_D (total)) is calculated as follows;

$$P_D (\text{total}) = P_D (\text{out}) + P_D (\text{bias}) = 0.0208 (\text{W}) + 0.0018 (\text{W}) = 0.0226 (\text{W})$$

The relation of P_D (the power dissipation) and T_a (the ambient temperature) in mounting on the board is shown in the following figure. Please design heat dissipation with enough margin after evaluating the thermal design for the board by referring to the above calculated values.

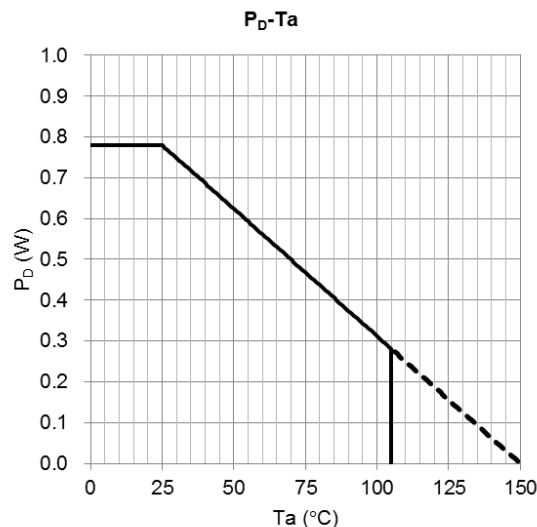

Board condition
 Size: 50 mm × 50 mm × 1.6 mm
 Cu 40% (Cu thickness 35 μm)
 When mounting glass epoxy
 single-sided board

Figure 6.4 Relation between (P_D) power dissipation and T_a (ambient temperature)

*The values shown in the above graphs are reference, not design values.

7. Application circuit example

Brushed DC motor drive Note1

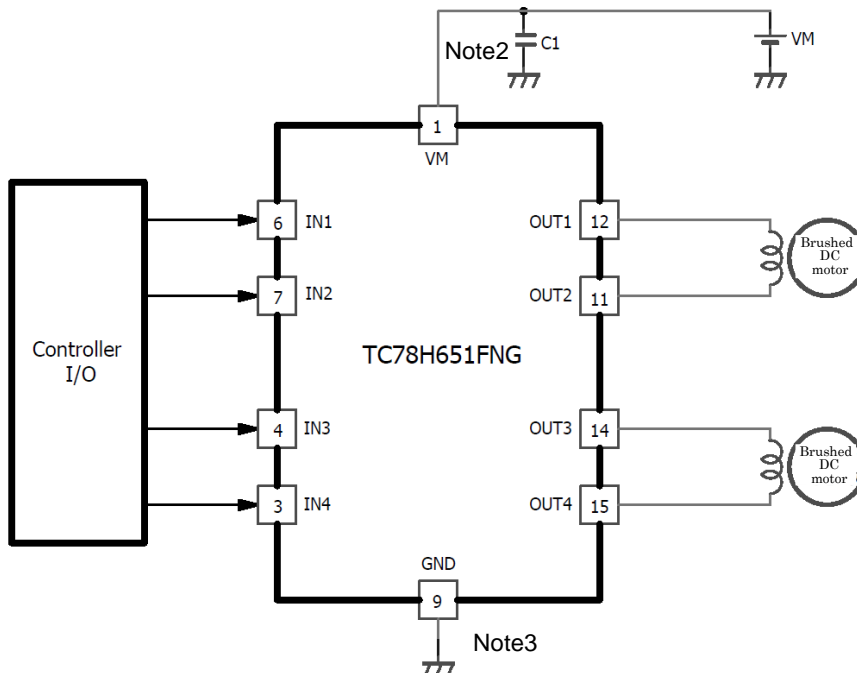

Figure 7.1 Example of application circuit (brushed DC motor)

Stepping motor drive

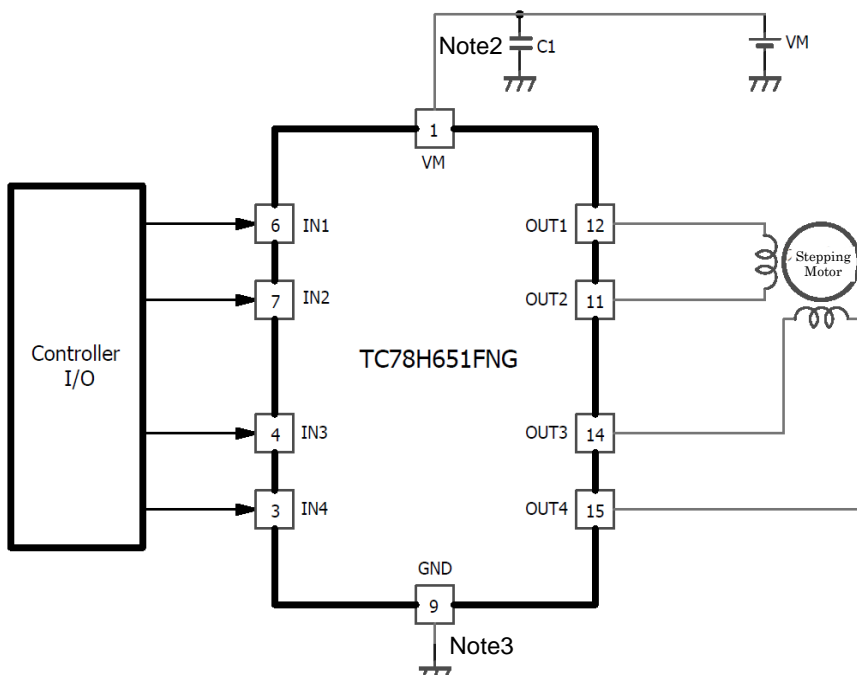

Figure 7.2 Example of application circuit (Stepping motor)

Note 1: Figure 7.1 shows the example of two brushed DC motors drive. If only one brushed DC motor is driven, the input pin of unused channel (H-Bridge) should be fixed to Low level (GND connection), and the output pin should be open.

Note 2: The capacitor (C1) for the power supply noise absorption should be connected to the IC as close as possible.

Note 3: Utmost care is necessary in the design of VM, and GND lines since the IC may be destroyed by short-circuiting between outputs, by short-circuiting to the power supply or ground, or by short-circuiting between contiguous pins.

* The pins (2, 5, 8, 10, 13, and 16 pin) which are described in the above figure are non-connection pins. Therefore these pins are connected to the IC internal circuit. These should be open. The application circuits shown in this document are provided for reference purposes only, and please evaluate enough for mass production

(1) Capacitor for the V_M power supply

To suppress the influence of power supply noise and counter electromotive force during inductive load driving and stabilize the power supply, a capacitor should be connected to V_M pin. To avoid voltage drop due to wiring impedance, connect the capacitor as close as possible to the IC. If an electrolytic capacitor is used, the voltage may be lowered by ESR. Therefore, a ceramic capacitor should be used because the ESR is low. Please determine the capacity value of the capacitor to be connected after confirming that the over shoot voltage which exceeds the maximum absolute ratings is not generated to V_M pin and OUT1 to 4 by motor back-EMF, in the maximum condition.

Table 7.1 Recommended capacitor values for V_M power supply

Item	Recommended range	Remarks
C1 for V_M power supply	0.01 to 10 μ F	Ceramic capacitor

(2) Wiring pattern for power supply / GND

Since large current may flow in V_M , OUT1 to 4, and GND pin patterns especially, design the appropriate wiring patterns to avoid the influence of wiring impedance.

8. I/O function

Table 8.1 List of I/O function

IN1	IN2	IN3	IN4	OUT1	OUT2	OUT3	OUT4	Mode
L	L	—	—	OFF	OFF	—	—	Stop
H	L	—	—	H	L	—	—	Forward
L	H	—	—	L	H	—	—	Reverse
H	H	—	—	(Note 1)	(Note 1)	—	—	—
—	—	L	L	—	—	OFF	OFF	Stop
—	—	H	L	—	—	H	L	Forward
—	—	L	H	—	—	L	H	Reverse
—	—	H	H	—	—	(Note 1)	(Note 1)	—
L	L	L	L	OFF	OFF	OFF	OFF	Standby

Note 1: "H" inputted previously is enable.

Note: "—" shows "Don't care."

Switching from IN1=L / IN2=L to IN1=H / IN2=H is "Don't care."

Switching from IN3=L / IN4=L to IN3=H / IN4=H is "Don't care."

9. Output switching characteristics

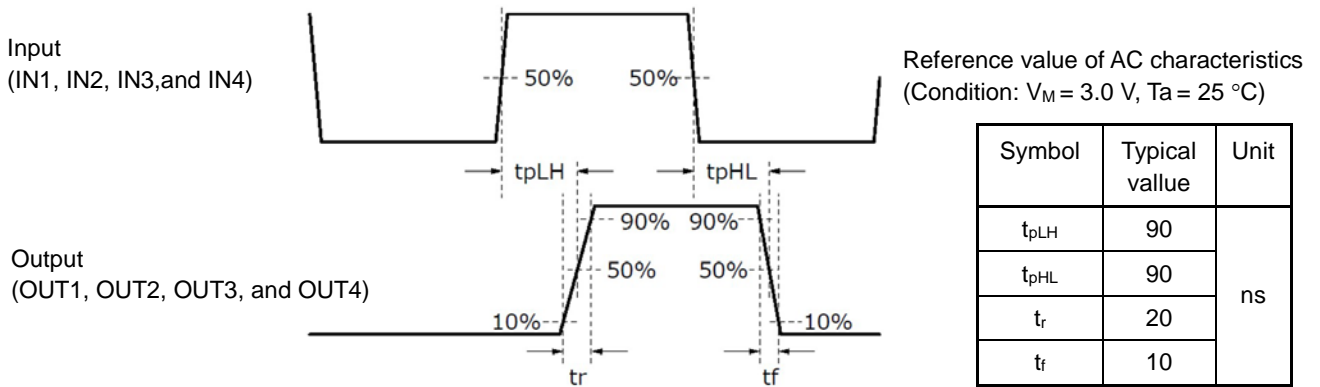

Figure 9.1 Timing chart of output waveform

* Timing charts may be simplified for explanatory purposes.

10. Error detection circuit

• Thermal shutdown circuit (TSD)

Thermal shutdown circuit (TSD) operates when the junction temperature reaches 170°C (typ.). All output power transistors are turned off.

The TSD operation is released when the junction temperature of IC falls to less than 130°C.

*Operation temperature and release temperature of TSD written above are a reference value, and are not guaranteed.

• Over-current detection circuit (ISD)

Over-current detection circuit operates when the current exceeding the threshold (refer to Figure 10.1) flows in the transistor which turns on in H-Bridge circuit. All output power transistors are turned off. The dead band time of 1.5 μs (typ.) is provided in the IC to avoid malfunction by switching etc. The ISD operation is released when one of the following controls is performed.

1. Re-investment of a power supply
2. After setting to standby mode (IN1/IN2/IN3/IN4=L), it sets to operational mode again.

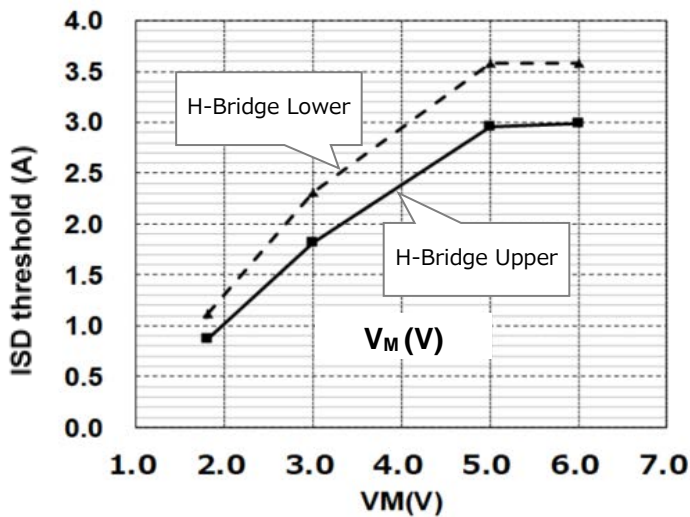

Figure 10.1 VM-ISD threshold

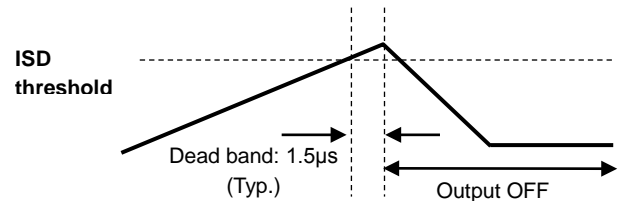

Figure 10.2 Dead band time of ISD

*The actuating current and masking term of the ISD are a reference value, and are not a guaranteed value.

• Under voltage lockout circuit (UVLO)

Under voltage detection circuit operates when VCC voltage falls to 1.7 V (typ.) or less. All output power transistors are turned off. The UVLO operation is released when the voltage applied to VM pin exceeds 1.7 V (typ.).

*Operation voltage and release voltage of UVLO written above are a reference value, and are not guaranteed.

11. Drive of bipolar stepping motor

Bipolar stepping motor drives with the input signal waveform shown below.

The current flowing through the motor coil connected between the OUT1 pin and the OUT2 pin is defined as I_{OUT_A} , and the current flowing through the motor coil connected between the OUT3 pin and OUT4 pin is defined as I_{OUT_B} .

The direction flowing from OUT1 to OUT2 (or OUT3 to OUT4) is defined as positive current and the direction flowing from OUT2 to OUT1 (or OUT4 to OUT3) is defined as negative current.

Step resolution mode: Full step resolution

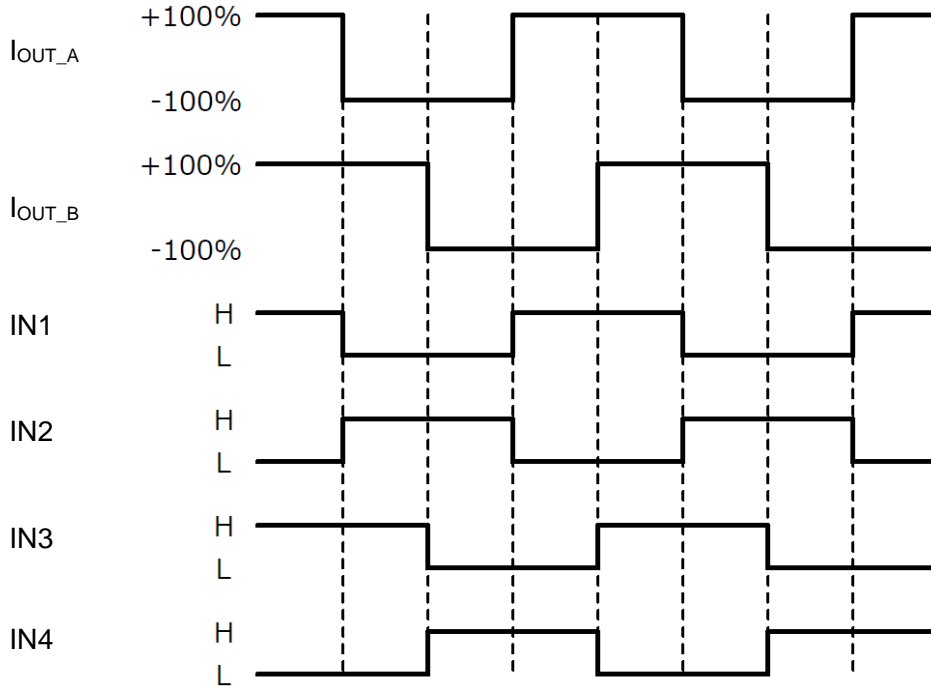

Step resolution mode: Half resolution

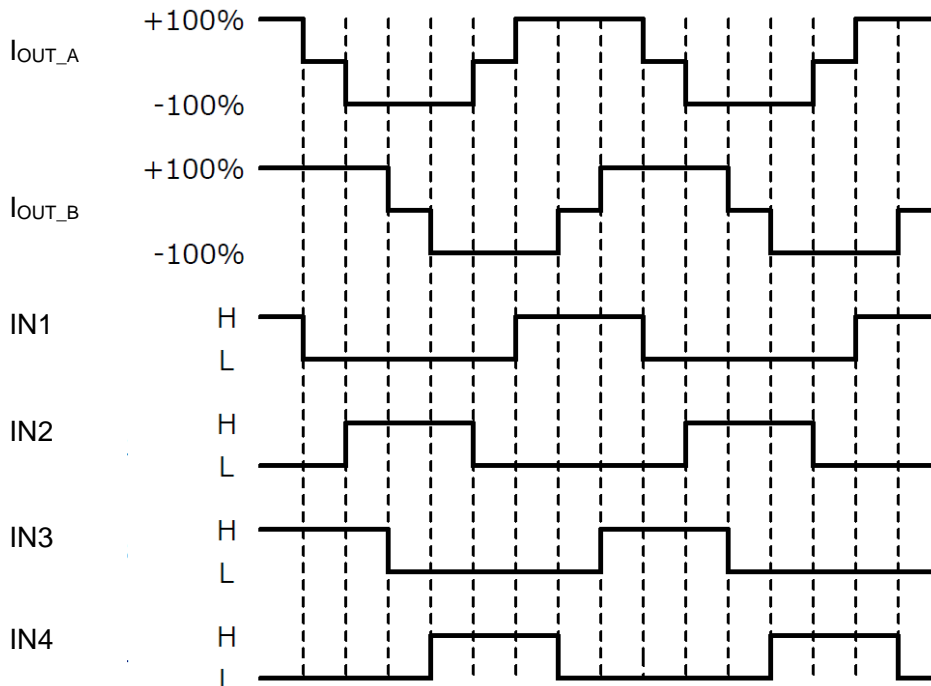

Figure 11.1 Input voltage waveform and Output current waveform of bipolar stepping motor drive

12. Reference land pattern example

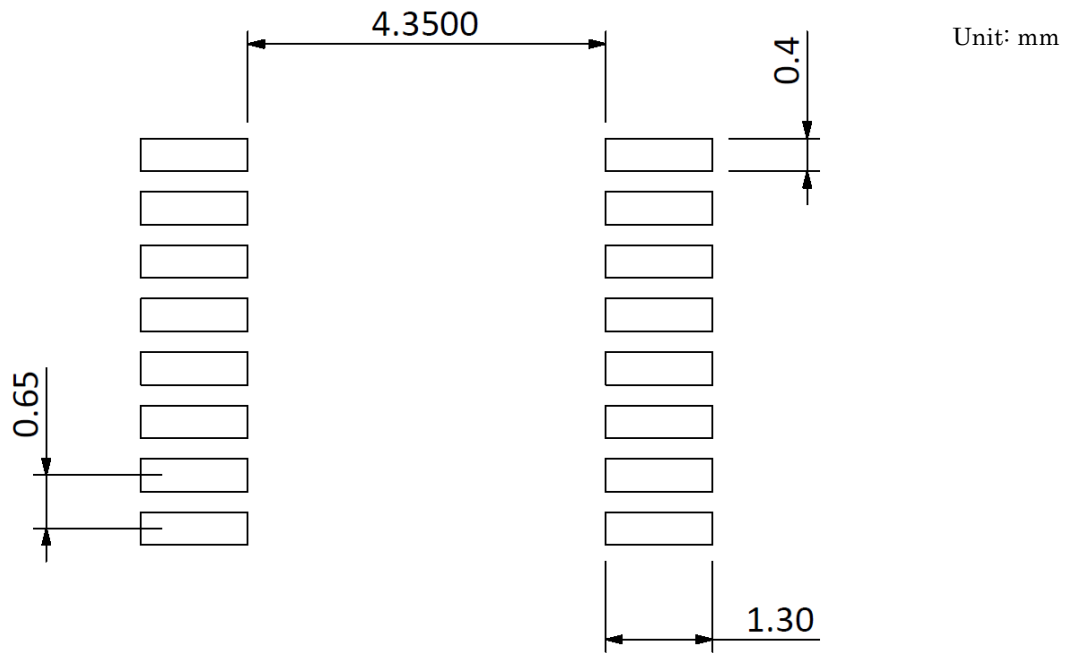

Figure 12.1 Reference land pattern

The land pattern is provided for reference purposes only, and are not guaranteed for mass production.

In determining the size of mounting board, design the most appropriate pattern by considering the solder bridge, the solder connecting strength, the pattern accuracy in making board, and the mounting accuracy of the IC board.

13. Evaluation board (Example of our original board)

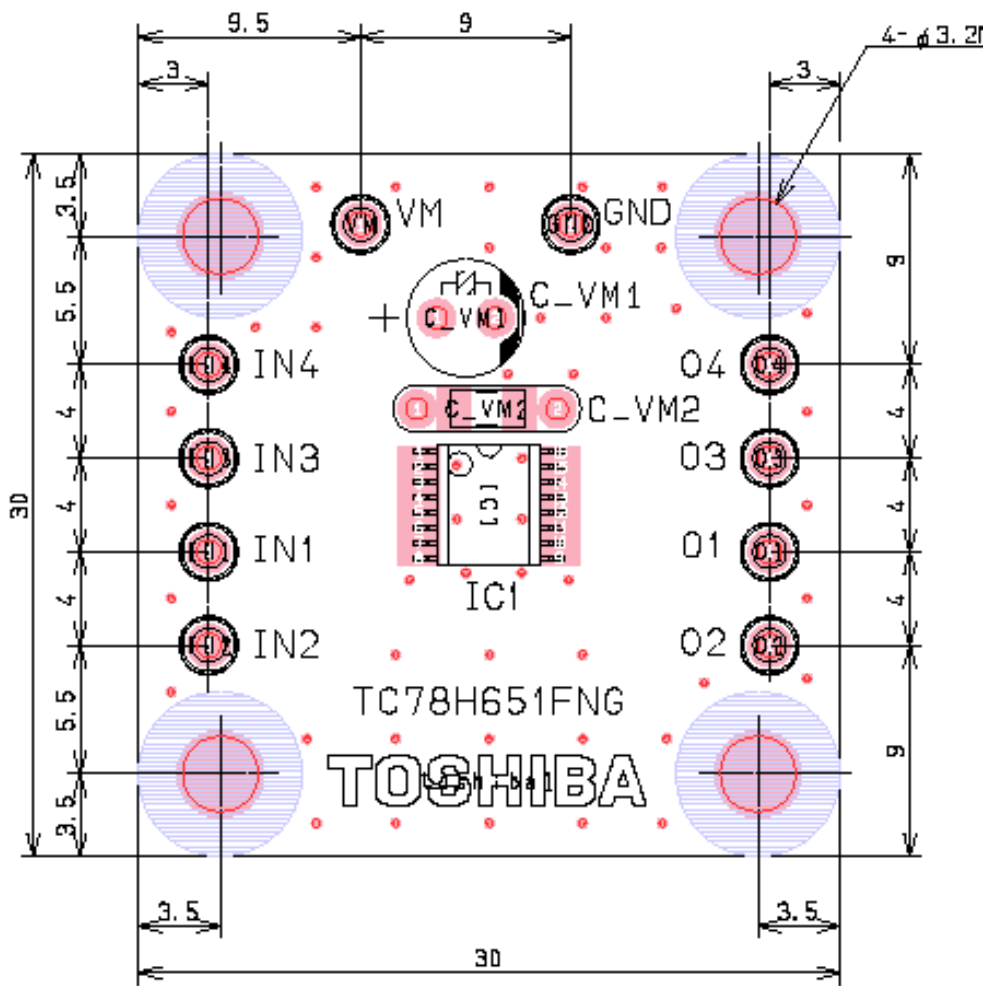

Figure 13.1 Our original evaluation board

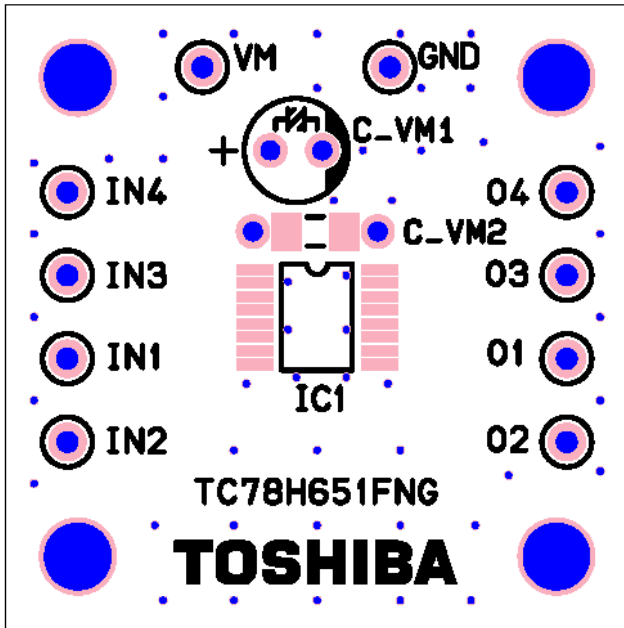

Figure 13.3 Evaluation board pattern layout (silk, resist-A)

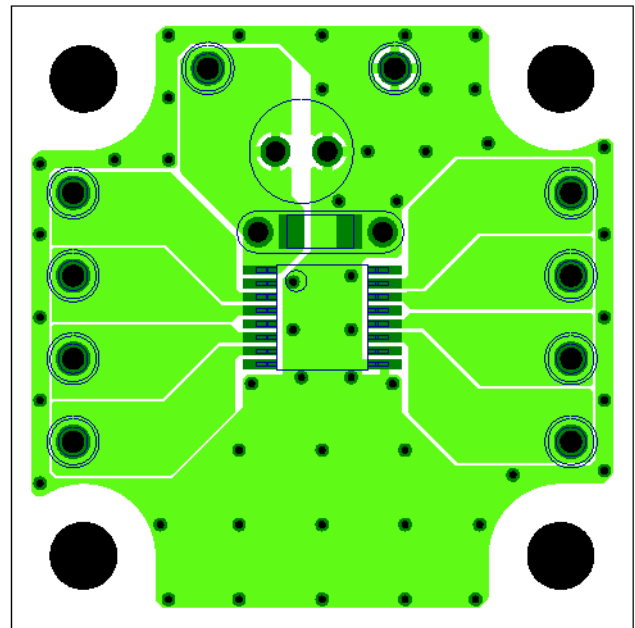

Figure 13.2 Evaluation board pattern layout (layer-1)

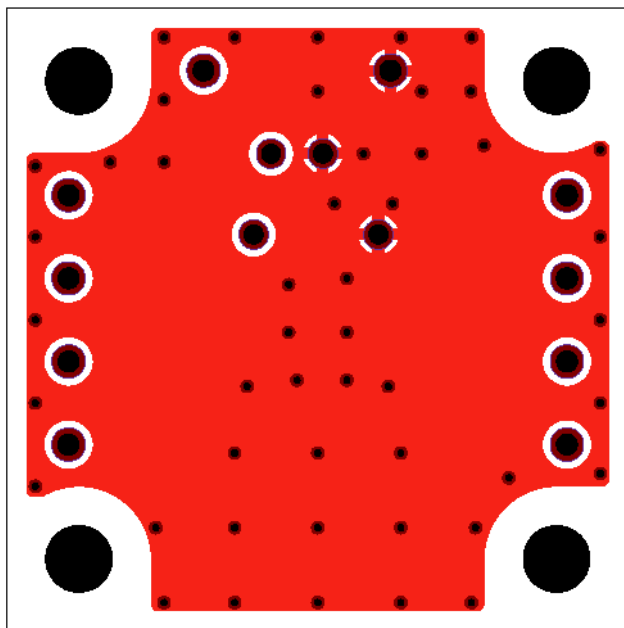

Figure 13.4 Evaluation board pattern layout (layer -2)

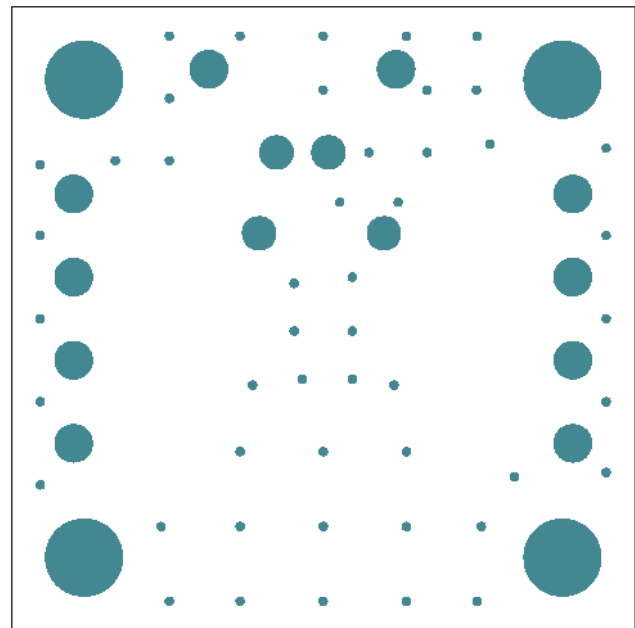
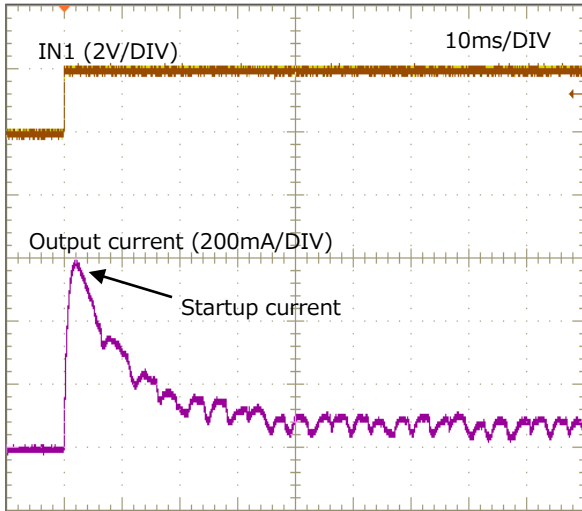

Figure 13.5 Evaluation board pattern layout (resist-B)

14. Operation waveform of motor drive (reference)

The following waveforms show the examples of typical motor drive.

Waveform of brushed DC motor drive
(at start-up, $V_M=5V$)



Waveform of brushed DC motor drive
(at PWM control, $V_M=5V$)

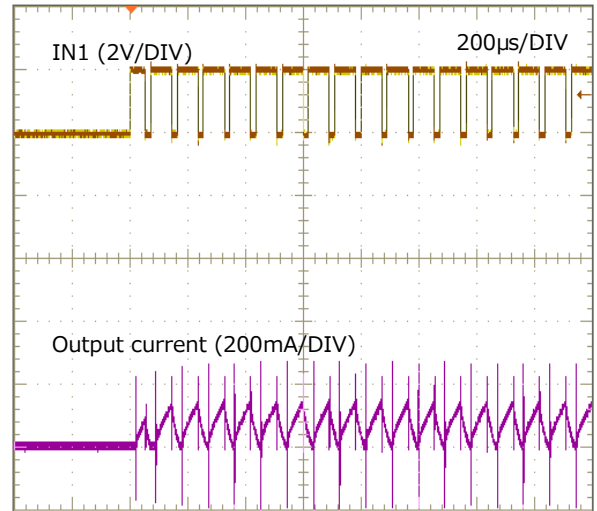

Waveform of stepping motor drive
(at Half step resolution, $V_M=5V$)

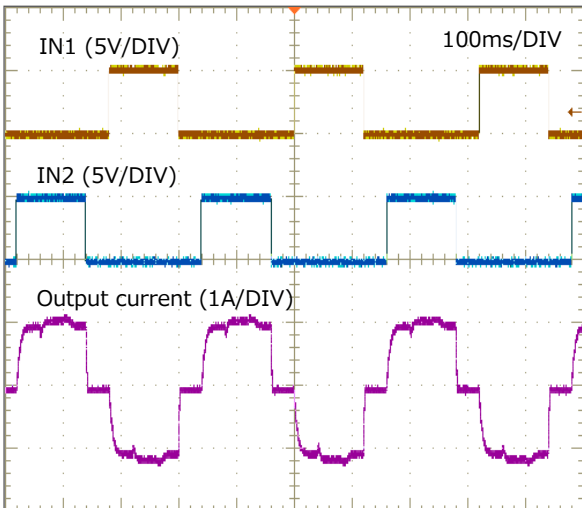

Waveform of the return operation from standby
($V_M=3V$)

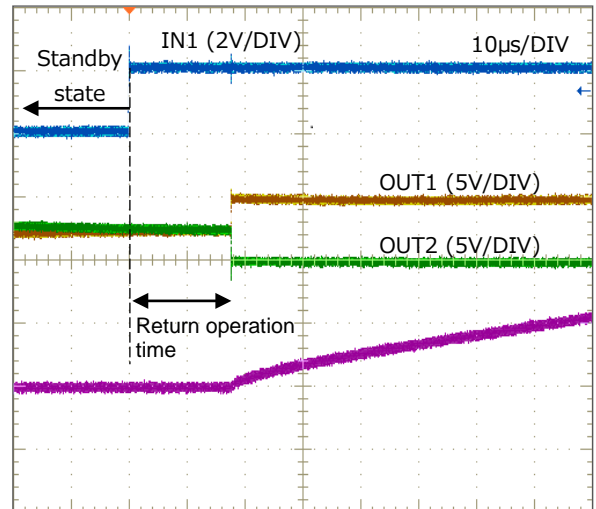

Waveform of ISD operation ($V_M=5V$)

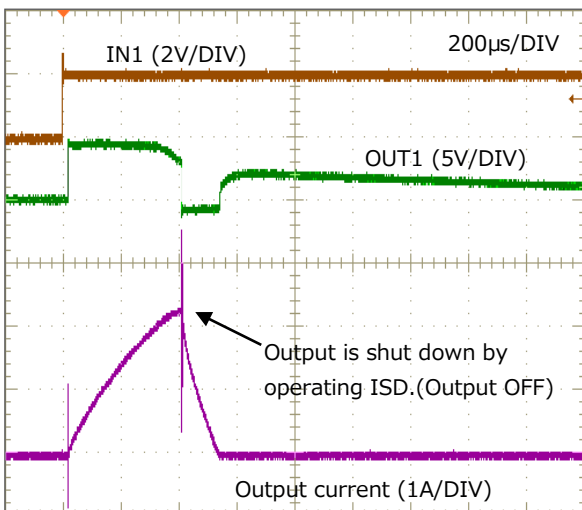

The following waveforms show the examples of a brushed DC motor drive with PWM signal control. The motor rotation speed and directions can be controlled by changing PWM signal duty which inputs to IN pins.

Waveform of PWM control
($f_{PWM}=100kHz$, 60% H Duty, $V_M=5V$)

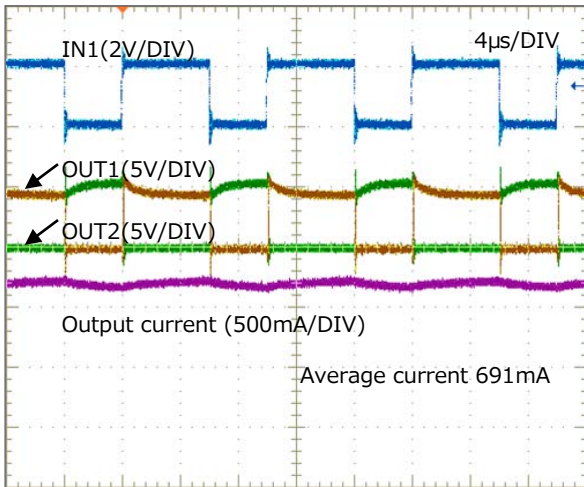

Waveform of PWM control
($f_{PWM}=500kHz$, 60% H Duty, $V_M=5V$)

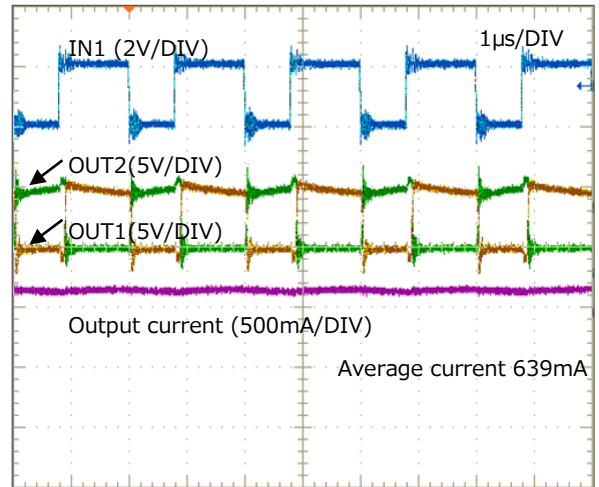

Waveform of PWM control
($f_{PWM}=100kHz$, 50% H Duty, $V_M=5V$)

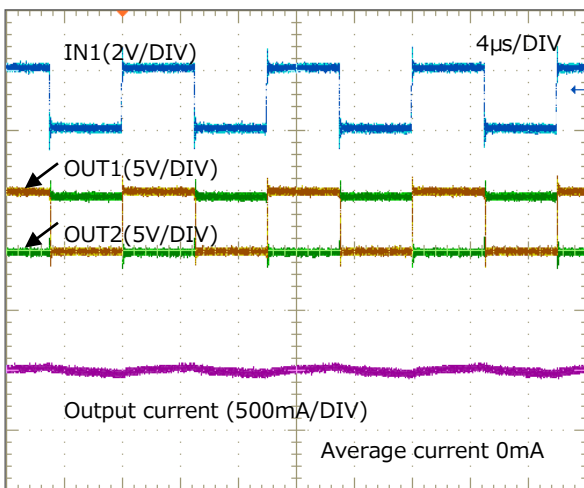

Waveform of PWM control
($f_{PWM}=500kHz$, 50% H Duty, $V_M=5V$)

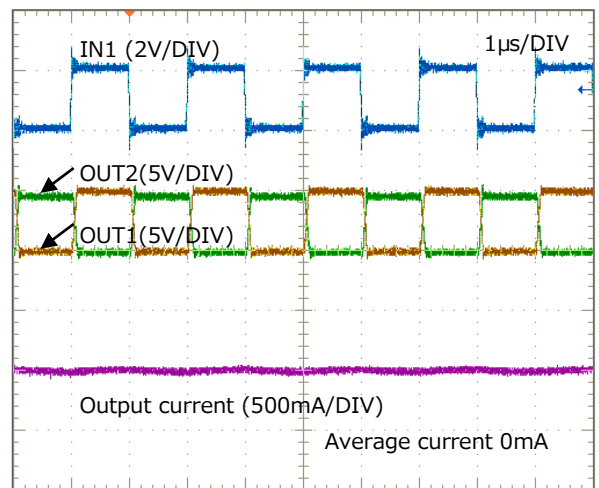

Waveform of PWM control
($f_{PWM}=100kHz$, 40% H-Duty, $V_M=5V$)

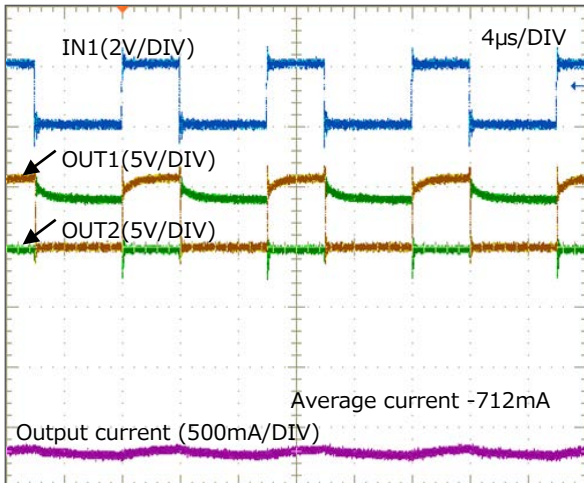

Waveform of PWM control
($f_{PWM}=500kHz$, 40% H Duty, $V_M=5V$)

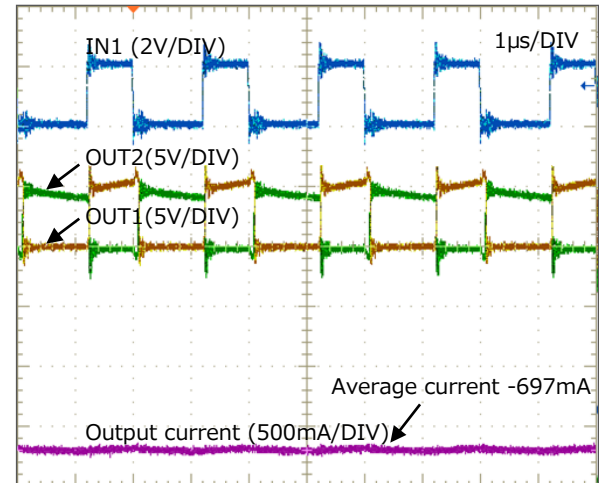

15. H-Bridge driver series product supporting low power supply voltage drive

Table 15.1 List of H-Bridge driver series product supporting low power supply voltage drive

	TC78H611FNG	TC78H621FNG	TC78H630FNG	TC78H651FNG	TC78H653FTG
Number of channels	2ch		1ch	2ch	2ch / 1ch
Rating	18V / 1.1A		18V / 2.1A	7V / 1.6A	2ch: 8V / 2.5A (peak) 1ch: 8V / 5A (peak)
Operating voltage	V _{CC} =2.7 to 5.5V V _M =2.5 to 15V			V _M =1.8 to 6.0V	V _M =1.8 to 7.0V
Standby function	Current consumption: 0 μA (typ.)				
PWM drive	Direct PWM				
Output propagation delay time	t _{pLH} =500 ns (typ.), t _{pHL} =500 ns (typ.)			t _{pLH} =90 ns (typ.), t _{pHL} =90 ns (typ.)	
Error detection	· TSD · ISD · UVLO				
Output ON-resistance (upper + lower)	0.8Ω (typ.)		0.4Ω (typ.)	0.22Ω (typ.)	2ch: 0.22Ω (typ.)
					1ch: 0.11Ω (typ.)
Package	TSSOP16 5.0 x 6.4 mm 0.65 mm pin pitch				WQFN16 3.0 x 3.0 mm 0.5 mm pin pitch

Though the TC78H651FNG integrates two H-Bridge circuits, the current capacity cannot be increased by connecting these inputs and outputs in parallel. The TC78H653FTG, which is the series product, is recommended for large current drive.

Notes on Contents

1. Block Diagrams

Some of the functional blocks, circuits, or constants in the block diagram may be omitted or simplified for explanatory purposes.

2. Equivalent Circuits

The equivalent circuit diagrams may be simplified or some parts of them may be omitted for explanatory purposes.

3. Timing Charts

Timing charts may be simplified for explanatory purposes.

4. Application Circuits

The application circuits shown in this document are provided for reference purposes only. Thorough evaluation is required, especially at the mass production design stage.

Providing these application circuit examples does not grant a license for industrial property rights.

5. Test Circuits

Components in the test circuits are used only to obtain and confirm the device characteristics. These components and circuits are not guaranteed to prevent malfunction or failure from occurring in the application equipment.

IC Usage Considerations

Notes on handling of ICs

- (1) The absolute maximum ratings of a semiconductor device are a set of ratings that must not be exceeded, even for a moment. Do not exceed any of these ratings. Exceeding the rating(s) may cause the device breakdown, damage or deterioration, and may result injury by explosion or combustion.
- (2) Do not insert devices in the wrong orientation or incorrectly. Make sure that the positive and negative terminals of power supplies are connected properly. Otherwise, the current or power consumption may exceed the absolute maximum rating, and exceeding the rating(s) may cause the device breakdown, damage or deterioration, and may result injury by explosion or combustion. In addition, do not use any device that is applied the current with inserting in the wrong orientation or incorrectly even just one time.
- (3) Use an appropriate power supply fuse to ensure that a large current does not continuously flow in case of over current and/or IC failure. The IC will fully break down when used under conditions that exceed its absolute maximum ratings, when the wiring is routed improperly or when an abnormal pulse noise occurs from the wiring or load, causing a large current to continuously flow and the breakdown can lead smoke or ignition. To minimize the effects of the flow of a large current in case of breakdown, appropriate settings, such as fuse capacity, fusing time and insertion circuit location, are required.
- (4) If your design includes an inductive load such as a motor coil, incorporate a protection circuit into the design to prevent device malfunction or breakdown caused by the current resulting from the inrush current at power ON or the negative current resulting from the back electromotive force at power OFF. IC breakdown may cause injury, smoke or ignition. Use a stable power supply with ICs with built-in protection functions. If the power supply is unstable, the protection function may not operate, causing IC breakdown. IC breakdown may cause injury, smoke or ignition.
- (5) Carefully select external components (such as inputs and negative feedback capacitors) and load components (such as speakers), for example, power amp and regulator. If there is a large amount of leakage current such as input or negative feedback condenser, the IC output DC voltage will increase. If this output voltage is connected to a speaker with low input withstand voltage, overcurrent or IC failure can cause smoke or ignition. (The over current can cause smoke or ignition from the IC itself.) In particular, please pay attention when using a Bridge Tied Load (BTL) connection type IC that inputs output DC voltage to a speaker directly.

Points to remember on handling of ICs**(1) Over current Protection Circuit**

Over current protection circuits (referred to as current limiter circuits) do not necessarily protect ICs under all circumstances. If the over current protection circuits operate against the over current, clear the over current status immediately.

Depending on the method of use and usage conditions, such as exceeding absolute maximum ratings can cause the over current protection circuit to not operate properly or IC breakdown before operation. In addition, depending on the method of use and usage conditions, if over current continues to flow for a long time after operation, the IC may generate heat resulting in breakdown.

(2) Thermal Shutdown Circuit

Thermal shutdown circuits do not necessarily protect ICs under all circumstances. If the thermal shutdown circuits operate against the over temperature, clear the heat generation status immediately.

Depending on the method of use and usage conditions, such as exceeding absolute maximum ratings can cause the thermal shutdown circuit to not operate properly or IC breakdown before operation.

(3) Heat Radiation Design

In using an IC with large current flow such as power amp, regulator or driver, please design the device so that heat is appropriately radiated, not to exceed the specified junction temperature (T_j) at any time and condition. These ICs generate heat even during normal use. An inadequate IC heat radiation design can lead to decrease in IC life, deterioration of IC characteristics or IC breakdown. In addition, please design the device taking into consideration the effect of IC heat radiation with peripheral components.

(4) Back-EMF

When a motor rotates in the reverse direction, stops or slows down abruptly, a current flow back to the motor's power supply due to the effect of back-EMF. If the current sink capability of the power supply is small, the device's motor power supply and output pins might be exposed to conditions beyond absolute maximum ratings. To avoid this problem, take the effect of back-EMF into consideration in system design.

RESTRICTIONS ON PRODUCT USE

Toshiba Corporation and its subsidiaries and affiliates are collectively referred to as "TOSHIBA".

Hardware, software and systems described in this document are collectively referred to as "Product".

- TOSHIBA reserves the right to make changes to the information in this document and related Product without notice.
- This document and any information herein may not be reproduced without prior written permission from TOSHIBA. Even with TOSHIBA's written permission, reproduction is permissible only if reproduction is without alteration/omission.
- Though TOSHIBA works continually to improve Product's quality and reliability, Product can malfunction or fail. Customers are responsible for complying with safety standards and for providing adequate designs and safeguards for their hardware, software and systems which minimize risk and avoid situations in which a malfunction or failure of Product could cause loss of human life, bodily injury or damage to property, including data loss or corruption. Before customers use the Product, create designs including the Product, or incorporate the Product into their own applications, customers must also refer to and comply with (a) the latest versions of all relevant TOSHIBA information, including without limitation, this document, the specifications, the data sheets and application notes for Product and the precautions and conditions set forth in the "TOSHIBA Semiconductor Reliability Handbook" and (b) the instructions for the application with which the Product will be used with or for. Customers are solely responsible for all aspects of their own product design or applications, including but not limited to (a) determining the appropriateness of the use of this Product in such design or applications; (b) evaluating and determining the applicability of any information contained in this document, or in charts, diagrams, programs, algorithms, sample application circuits, or any other referenced documents; and (c) validating all operating parameters for such designs and applications. **TOSHIBA ASSUMES NO LIABILITY FOR CUSTOMERS' PRODUCT DESIGN OR APPLICATIONS.**
- **PRODUCT IS NEITHER INTENDED NOR WARRANTED FOR USE IN EQUIPMENTS OR SYSTEMS THAT REQUIRE EXTRAORDINARILY HIGH LEVELS OF QUALITY AND/OR RELIABILITY, AND/OR A MALFUNCTION OR FAILURE OF WHICH MAY CAUSE LOSS OF HUMAN LIFE, BODILY INJURY, SERIOUS PROPERTY DAMAGE AND/OR SERIOUS PUBLIC IMPACT ("UNINTENDED USE").** Except for specific applications as expressly stated in this document, Unintended Use includes, without limitation, equipment used in nuclear facilities, equipment used in the aerospace industry, lifesaving and/or life supporting medical equipment, equipment used for automobiles, trains, ships and other transportation, traffic signaling equipment, equipment used to control combustions or explosions, safety devices, elevators and escalators, and devices related to power plant. **IF YOU USE PRODUCT FOR UNINTENDED USE, TOSHIBA ASSUMES NO LIABILITY FOR PRODUCT.** For details, please contact your TOSHIBA sales representative or contact us via our website.
- Do not disassemble, analyze, reverse-engineer, alter, modify, translate or copy Product, whether in whole or in part.
- Product shall not be used for or incorporated into any products or systems whose manufacture, use, or sale is prohibited under any applicable laws or regulations.
- The information contained herein is presented only as guidance for Product use. No responsibility is assumed by TOSHIBA for any infringement of patents or any other intellectual property rights of third parties that may result from the use of Product. No license to any intellectual property right is granted by this document, whether express or implied, by estoppel or otherwise.
- **ABSENT A WRITTEN SIGNED AGREEMENT, EXCEPT AS PROVIDED IN THE RELEVANT TERMS AND CONDITIONS OF SALE FOR PRODUCT, AND TO THE MAXIMUM EXTENT ALLOWABLE BY LAW, TOSHIBA (1) ASSUMES NO LIABILITY WHATSOEVER, INCLUDING WITHOUT LIMITATION, INDIRECT, CONSEQUENTIAL, SPECIAL, OR INCIDENTAL DAMAGES OR LOSS, INCLUDING WITHOUT LIMITATION, LOSS OF PROFITS, LOSS OF OPPORTUNITIES, BUSINESS INTERRUPTION AND LOSS OF DATA, AND (2) DISCLAIMS ANY AND ALL EXPRESS OR IMPLIED WARRANTIES AND CONDITIONS RELATED TO SALE, USE OF PRODUCT, OR INFORMATION, INCLUDING WARRANTIES OR CONDITIONS OF MERCHANTABILITY, FITNESS FOR A PARTICULAR PURPOSE, ACCURACY OF INFORMATION, OR NONINFRINGEMENT.**
- Do not use or otherwise make available Product or related software or technology for any military purposes, including without limitation, for the design, development, use, stockpiling or manufacturing of nuclear, chemical, or biological weapons or missile technology products (mass destruction weapons). Product and related software and technology may be controlled under the applicable export laws and regulations including, without limitation, the Japanese Foreign Exchange and Foreign Trade Law and the U.S. Export Administration Regulations. Export and re-export of Product or related software or technology are strictly prohibited except in compliance with all applicable export laws and regulations.
- Please contact your TOSHIBA sales representative for details as to environmental matters such as the RoHS compatibility of Product. Please use Product in compliance with all applicable laws and regulations that regulate the inclusion or use of controlled substances, including without limitation, the EU RoHS Directive. **TOSHIBA ASSUMES NO LIABILITY FOR DAMAGES OR LOSSES OCCURRING AS A RESULT OF NONCOMPLIANCE WITH APPLICABLE LAWS AND REGULATIONS.**