

# Smart Gate Driver Coupler Tips for Designing DESAT Detection Circuits

## Description

This document summarizes some tips for designing peripheral circuits that should be noted when you use the  $V_{CE(sat)}$  detection function of a smart gate driver coupler such as TLP5214A/TLP5214/TLP5212/TLP5222.

The  $V_{CE(sat)}$  detection (DESAT detection) circuit which detects the rise of the collector or drain voltage ( $V_{CE}$ ) when an over-current flows into the power semiconductor switch device (hereinafter referred to 'power device') driven by the gate driver by causes, such as a short circuit of load, makes the power device turn off, and protects it. However, the  $V_{CE}$  may rise unusually and largely due to the inductances of the loads when the power device switches, and if it enters the DESAT terminal, an erroneous detection of the DESAT detection circuit may occur. In three-phase inverters and other inverters, noise generated during switching of other phases may cause an erroneous detection of the DESAT detection circuit due to noise circulating through power supply lines and GND lines or electromagnetic induction between wires.

This document provides tips to reduce the likelihood of DESAT false detections.

. Do not design your products or systems based on the information on this document. Please contact your Toshiba sales representative for updated information before designing your products.

## Table of Contents

Description.....	1
Table of Contents.....	2
List of Figures.....	2
1. DESAT Detection Circuit.....	3
2. Noise intrusion path.....	4
3. Tips on circuit wiring pattern design .....	5
4. Tips for determining the constants of DESAT detection circuits .....	6
Revision history .....	11
Notes on Contents.....	12
Usage Considerations .....	12
RESTRICTIONS ON PRODUCT USE .....	13

## List of Figures

Figure 1.1 Gate Driver Circuit with DESAT Detection Function .....	3
Figure 2.1 Noise Intrusion Image .....	4
Figure 2.2 Image of Parasitic Elements in Wiring Pattern.....	4
Figure 3.1 Notes on Wiring Routing .....	5
Figure 3.2 Shielding Image of DESAT Circuit Wiring Patterns.....	5
Figure 4.1 Noise Reduction by the Filter .....	6
Figure 4.2 Protective Devices and $R_B$ .....	8
Figure 4.3 Voltage Chart for DESAT Detection .....	10
Figure 4.4 Timing Chart for DESAT Detection of TLP5214A .....	10

## 1. DESAT Detection Circuit

At first, following is the brief review of the DESAT detection circuit.

The DESAT detection function built in a smart gate driver (SGD) coupler such as TLP5214A/TLP5214/TLP5212/TLP5222 is designed to protect the power device (IGBT, Si or SiC-MOSFET, and GaN-FET, but the IGBT will be exemplified in the following explanation) from excessive currents such as load-shorting current, which may cause breakdown.

The DESAT detection circuit detects the voltage at the collector or drain of the power device to be driven through the DESAT terminal. When the voltage exceeds the specified voltage ( $V_{DESAT}$ ), the SGD coupler stops the power device and outputs a fault signal from the FAULT\_N terminal.

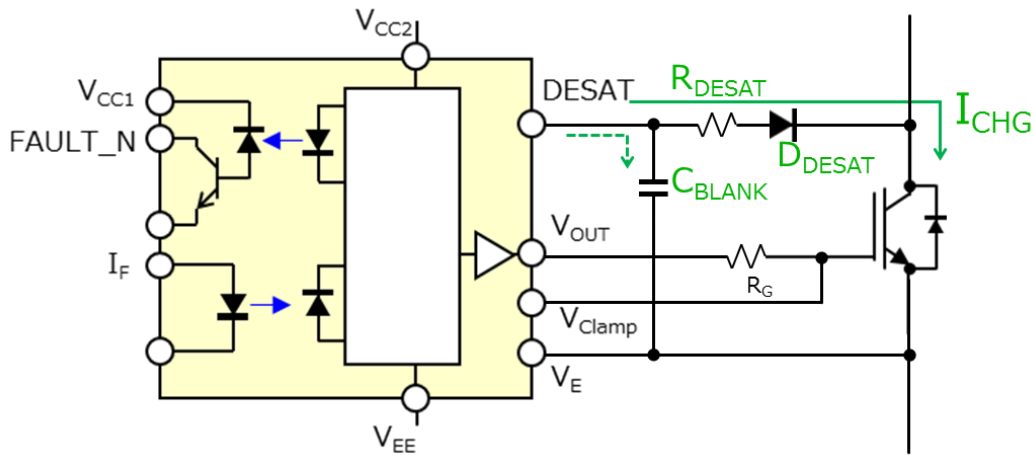

**Figure 1.1 Gate Driver Circuit with DESAT Detection Function**

In this example shown in Figure 1.1, the IGBT is driven by the TLP5214A. When the IGBT to be driven is on ( $V_{OUT}$  is H),  $I_{CHG}$  is flowing out of the DESAT terminal, and the  $C_{BLANK}$  connected to the DESAT terminal and the  $V_E$  terminal is about to be charged. However, since the IGBT is ON, the  $V_{CE}$  is saturated, and the  $I_{CHG}$  flows into the IGBT through the  $R_{DESAT}$  and  $D_{DESAT}$ , so the  $C_{BLANK}$  is not charged to the DESAT threshold voltage  $V_{DESAT}$ .

If the  $V_{CE}$  of the IGBT rises due to an overcurrent caused by a load short circuit or the like, the  $I_{CHG}$  cannot flow into the IGBT, and the  $C_{BLANK}$  starts to be charged. If the DESAT terminal exceeds the threshold voltage  $V_{DESAT}$ , the SGD determines that IGBT's desaturation (DESAT) status has been detected (excessive current has flowed), and  $V_{OUT}$  shifts soft shutdown mode to turn off the IGBT. FAULT\_N signals are also outputted to the controller.

$t_{BLANK}$  time since  $C_{BLANK}$  begins to be charged, until protected operation starts is calculated from the saturated voltage  $V_{CE(sat)}$  of the IGBT and the forward voltage  $V_F$  of the  $D_{DESAT}$  and the voltage drop of the  $R_{DESAT}$ .

$$t_{BLANK} = \{ C_{BLANK} \times ( V_{DESAT} - ( V_F + I_{CHG} \times R_{DESAT} ) ) \} / I_{CHG} \dots\dots\dots ( \text{Equation 1} )$$

This ' $t_{BLANK}$ ' must be shorter than the short circuit withstand time ( $t_{sc}$ ) of the IGBT.

See "[Smart Gate Driver Coupler TLP5214A/TLP5214/TLP5212/TLP5222 Application Note - Advanced edition-](#)" Section 4.2 'Setting and adjusting blanking times' for  $t_{BLANK}$ .

We will present the subject matter in the next chapter.

## 2. Noise intrusion path

The power device may be installed several cm to several tens of cm away from the SGD because it is a module, or if it is a single unit, it may be equipped with a radiator, or it may be connected with a thick wiring to allow a large load current to flow. Therefore, the length of the three wires (DESAT detection, gate-drive, and emitter-common) from the SGD is required. So, the wiring itself may act as an antenna and cause electromagnetic induction from the wiring with a large load current, or if there are multiple phases in inverter applications, electromagnetic induction from the load current due to switching of other phases, or noise may be introduced from gate-drive signals of other phases through the parasitic capacitance between the wiring pattern, etc. The image is shown in Figure 2.1.

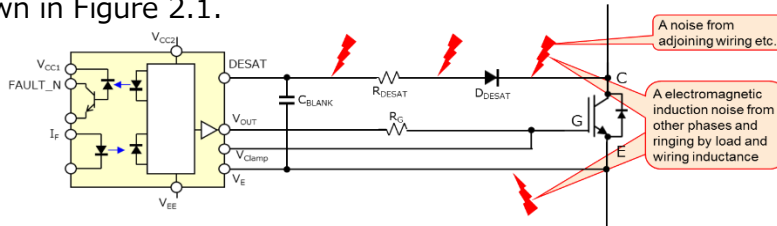

**Figure 2.1 Noise Intrusion Image**

On printed circuit boards, the voltage signal transmitted by wiring influences between adjacent wirings due to parasitic capacitance, etc., and the current signal flowing between adjacent wirings influences by electromagnetic induction. In particular, the current controlled by the IGBT is as large as several amperes to several hundred amperes, so a large induced magnetic field is generated. In IGBT gate-drive wirings, a peak current of several amperes or more flows to rapidly charge the gate capacitance, which may have a large effect on the surrounding area. Again, parasitic resistance, inductance, and capacitance components are always present in the wiring. For example, a change in the current flowing through the wiring causes a localized change in the voltage due to the resistance and inductance components, and a change in the voltage causes a charge and discharge of the capacitance components, resulting in a change in the current. As described above, not only signals but also voltage changes generated by parasitic components are mutually introduced as voltage noise through parasitic capacitance between wirings, and changes in current are mutually intertwined in a complicated manner as current and voltage noise by electromagnetic induction between parallel wirings.

The wiring of the DESAT detection circuit is wired on the board of the above-mentioned environments, and the circuit impedances are relatively high. Therefore, the wiring around the DESAT detection circuit wiring is susceptible to the influence of the wiring, which may lead to erroneous detection of the DESAT.

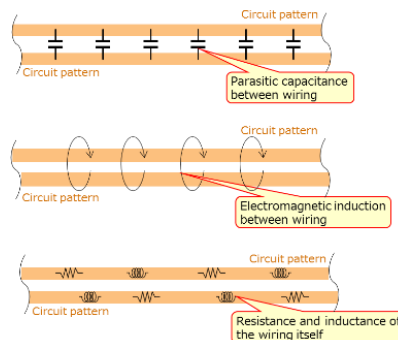
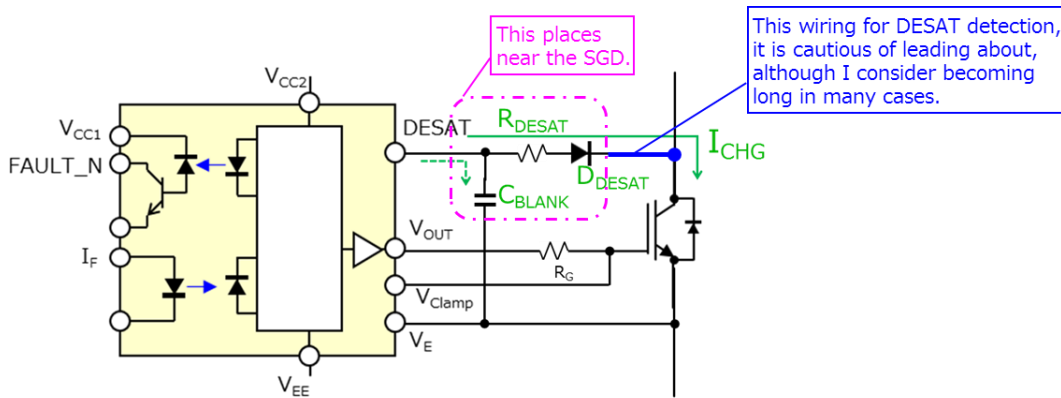

**Figure 2.2 Image of Parasitic Elements in Wiring Pattern**

### 3. Tips on circuit wiring pattern design

In order to reduce the malfunction of DESAT detections due to noises around the wiring described above, the following points should be noted on the wiring patterns. DESAT-pin is more impedances than other wiring and is more susceptible to inductions and entering from other wiring. Therefore, the wiring should not be adjacent to the wiring through which current pulses flow or to the wiring tied to nodes where large potential fluctuations occur.

- (1) The wiring for DESAT detection is not brought close to the DESAT detection wiring of the other power devices connected to the collectors (drains) of the power devices having the highest voltage fluctuations.
- (2) The wiring for DESAT detection does not run parallel to the gate drive wiring of the IGBT through which the current pulses flow.
- (3) The  $R_{DESAT}$ ,  $D_{DESAT}$ , and  $C_{BLANK}$  should be placed near the SGD so that the low-pass filtering effects of the  $R_{DESAT}$ ,  $D_{DESAT}$ , and  $C_{BLANK}$  can be maximized. (The effect of the filter will be described later.)



**Figure 3.1 Notes on Wiring Routing**

If feasible, in order to protect the wiring for DESAT detection from noises so as not to cause a DESAT detection malfunction, it may be effective to surround the right and left sides of the wiring with the common potential ( $V_E$  or  $V_{EE}$ ) of the SGD in parallel with the multilayered wiring layers or the wiring for DESAT detection. Note that this is not the system's GND potential, but the common potential of the SGD itself, which is the criterion for DESAT detection. The DESAT detection operates with the  $V_E$  pin connected to the emitters (sources) of the power device as the reference potential. Therefore, it is meaningless if the wiring for DESAT detection is shielded by the common potential of the SGD itself. System GNDs are one of the biggest sources of noise, particularly when driving Upper-Side power devices in inverter applications.

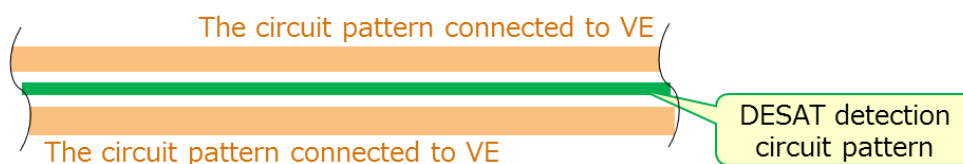

**Figure 3.2 Shielding Image of DESAT Circuit Wiring Patterns**

## 4. Tips for determining the constants of DESAT detection circuits

This section presents tips on the  $C_{BLANK}$  and  $R_{DESAT}$  values of the DESAT detection circuit and how to select the  $D_{DESAT}$ .

The blanking time  $t_{BLANK}$  based on the short circuit withstand time of the power device is described in detail in Section 4 of the [“Smart Gate Driver Coupler TLP5214A/TLP5214/TLP5212/TLP5222 Application Note -Advanced edition-”](#). For details, let us say that the time  $t_{BLANK}$  (Equation 1 on page 3) from the time when the IGBT  $V_{CE}$  rises due to excessive current flowing, the  $I_{CHG}$  stops flowing to the IGBT, and the  $C_{BLANK}$  begins to charge until the DESAT terminal exceeds the  $V_{DESAT}$  is set to be shorter than the short circuit withstand time.

From the point of view of protecting the IGBT,  $t_{BLANK}$  should be shorter. However, even if attention is paid to the layout of components and wiring patterns as described above,  $C_{BLANK}$  may be charged by large noises and DESAT-pin voltage exceed the  $V_{DESAT}$ , and a malfunction may occur in the FAULT state. Because, it is for that the input impedance of the DESAT-pin is high when the LED for driving signals are on. Then, a low-pass filter is formed using the  $C_{BLANK}$ ,  $R_{DESAT}$ , and  $D_{DESAT}$  to prevent it.

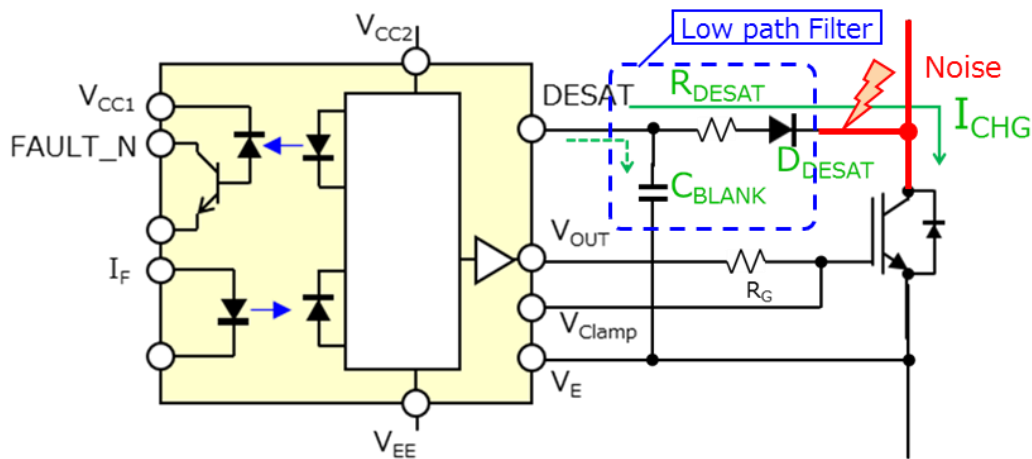

Figure 4.1 Noise Reduction by the Filter

Consider the constants of each device from the viewpoint of the low-pass filter configuration. The larger the  $C_{BLANK}$  and  $R_{DESAT}$ , the smaller the junction capacitance of the  $D_{DESAT}$ , the more effective the filter becomes.

1.  $D_{DESAT}$ : A diode with a small current-capacity (about 100mA) is sufficient because the only forward current flowing is the  $I_{CHG}$ . You should use a diode with a reverse breakdown voltage sufficiently approximately twice or higher than the power supply voltage of the IGBT. And you should use a diode with a smaller junction capacitance to prevent DESAT malfunction. Also, it is also effective to use two or more diodes in series. When the diodes

are connected in series, the junction capacitance is reduced by a factor of the number of the diodes connected in series, which is effective from the viewpoint of reducing the junction capacitance. However, a reverse breakdown voltage of the diodes should be higher than the power supply voltage of the IGBT. Because the reverse breakdown voltage applied when the IGBT is off may not be applied uniformly to the diodes in series due to variations in leakage current among the diodes. This is related also to calculation of the IGBT short detection threshold voltage ( $V_{th(IGBT)}$ ). See "[Smart Gate Driver Coupler TLP5214A/TLP5214/TLP5212/TLP5222 Application Note -Advanced edition-](#)" Section 4.5 'Modifying the IGBT short detection threshold voltage'.

2.  $C_{BLANK}$ : For example,  $t_{BLANK}$  is set to  $5\mu s$ . Since the standard value of  $I_{CHG}$  in TLP5214A is  $240\mu A$ ,  $C_{BLANK}$  will choose about 200 pF from the Equation 1 on page 3. If the  $C_{BLANK}$  is 200pF and the junction capacitance of the  $D_{DESAT}$  is 20pF and noise of 100Vp-p is generated in the  $V_{CE}$ , the peak voltage of  $C_{BLANK}$  is calculated by the voltage division of capacitances.

$$100V \times 20pF / ( 200pF + 20pF ) = 9.1V$$

This noise voltage exceeds the  $V_{DESAT}$  (= 6.5V), and may causes malfunction of the FAULT. Therefore, from the viewpoint of capacitance,  $C_{BLANK}$  is increased, or a diode with a smaller junction capacitance is chosen as the  $D_{DESAT}$ . If smaller diodes are not available, you use the  $C_{BLANK}$  with larger capacitance. When 470pF is used as an example, even if the junction capacitance of the  $D_{DESAT}$  is 20pF and noise of 100Vp-p is generated in the  $V_{CE}$ , the noise voltage applied to  $C_{BLANK}$  is reduced as follows.

$$100V \times 20pF / ( 470pF + 20pF ) = 4.1V$$

However, at 470pF, the  $t_{BLANK}$  exceeds  $5\mu s$ , so be careful not to exceed the short circuit withstand time of the IGBT. If the  $t_{BLANK}$  needs to be shortened when the  $C_{BLANK}$  is increased, the charge current of the  $C_{BLANK}$  can be increased by adding an  $R_B$  and the  $I_B$  is added to  $I_{CHG}$ . When connecting a Zener diode or a Schottky barrier diode as shown in Figure 4.2 to protect the DESAT terminal, the components have junction capacitances and are added to the  $C_{BLANK}$  as parallel capacitances. The  $t_{BLANK}$  must be calculated in addition to the  $C_{BLANK}$ . You consider when designing. See "[Smart Gate Driver Coupler TLP5214A/TLP5214/TLP5212/TLP5222 Application Note -Advanced edition-](#)" Section 4.4 'Setting the time using an external blanking circuit ( $R_B$ )' for  $R_B$  calculation.

3.  $R_{DESAT}$ : Considering a low-pass filter for noise reduction, if the time constants of the  $R_{DESAT}$  and  $C_{BLANK}$  are increased, the filter effect for high frequency noise increases for impulses and ringing noise, and false DESAT detection can be decreased. When the IGBT is on, the  $I_{CHG}$  flows through the  $R_{DESAT}$ , so that the voltage drop increases by the increase of the  $R_{DESAT}$ . If an  $R_B$  is added, care must be taken because the  $I_B$  and the  $I_{CHG}$  flow through the  $R_{DESAT}$  and the voltage drop is increased. The adjustment of  $V_{th(IGBT)}$  must be taken into account.





For reference,  $I_B$  and the constants of the DESAT detection system in TLP5214A are calculated. The voltage chart for DESAT detection is shown in Figure 4.3. The voltage concerning  $C_{BLANK}$  in case IGBT is ON state, i.e., the voltage drop of  $D_{DESAT}$  and  $R_{DESAT}$  and the saturation voltage  $V_{CE(sat)}$  of IGBT, is defined as  $V_{CBLK(ON)}$ . Therefore, the following formula is realized.

$$V_{DESAT} = V_{th(IGBT)} + V_{CBLK(ON)}$$

$V_{CBLK(ON)}$  is decided and calculation is begun. If  $V_{th(IGBT)}$  is decided first, please calculate  $V_{CBLK(ON)}$  using the following formulas.

$$V_{CBLK(ON)} = V_{DESAT} - V_{th(IGBT)}$$

- Calculation condition (It is calculation in case  $V_{OUT}$  is H, i.e., IGBT is ON state.)
  - (a) The voltage drop between the  $V_{CC2}$  and the  $V_{OUT}$  is approximated as zero because the voltage drop is in the very small current range.
  - (b) The  $V_{CE(sat)}$  of the IGBT is assumed to be 1.8V.
  - (c) The  $V_F$  of the DESAT diodes ( $D_{DESAT}$ ) is assumed to be 0.7V.
  - (d) The  $C_{BLANK}$  is 1500pF to reduce malfunction due to noises.
  - (e) The short circuit withstand time of the IGBT is set to 10 $\mu$ s, and the margins are set to 7 $\mu$ s.
  - (f) The  $V_{CBLK(ON)}$  is 3.0V.
  - (g) Supply voltage of SDG is  $V_p = V_m = 15V$ .

Calculation based on the above conditions.

$$\begin{aligned} t_{BLANK} &= 7\mu s = \{ C_{BLANK} \times V_{th(IGBT)} \} / ( I_{CHG} + I_B ) \\ &= \{ C_{BLANK} \times ( V_{DESAT} - V_{CBLK(ON)} ) \} / ( I_{CHG} + I_B ) \\ &= \{ 1500pF \times ( 6.5V - 3.0V ) \} / ( 240\mu A + I_B ) \end{aligned}$$

From the above,  $I_B = 510\mu A$  can be obtained. If we further calculate the  $R_B$ ,

$$R_B = ( V_p - V_{CBLK(ON)} ) / I_B = ( 15V - 3.0V ) / 510\mu A = 24k\Omega$$

Since the  $V_{CBLK(ON)}$  is 3.0V,

$$\begin{aligned} V_{CBLK(ON)} &= V_{CE(SAT)} + V_{F(DDESAT)} + R_{DESAT} \times ( I_B + I_{CHG} ) \\ 3.0V &= 1.8V + 0.7V + R_{DESAT} \times ( 510\mu A + 240\mu A ) \end{aligned}$$

Therefore, the  $R_{DESAT}$  is 667 $\Omega$ .

The time constants of the low-pass filter with  $R_{DESAT}$  and  $C_{BLANK}$  are  $667\Omega \times 1500pF = 1\mu s$ . In the examples, the  $V_{CBLK(ON)}$  was set to 3.0V, but note that increasing the  $V_{CBLK(ON)}$  decreases the potential difference(= $V_{th(IGBT)}$ ) with respect to the  $V_{DESAT}$  and reduces the noise margins. If a short circuit is detected immediately after turning on the LED for signals, it is necessary to consider not only the  $t_{BLANK}$  calculated in the examples but also the time required for the  $t_{DESAT(LEB)}$  and the time required for the DESAT terminal to change from the  $V_E$  potential to the  $V_{CBLK(ON)}$ . It is recommended that the  $V_{CBLK(ON)}$  be set lower. For reference, the timing chart for DESAT detection of TLP5214A is shown Figure 4.4.

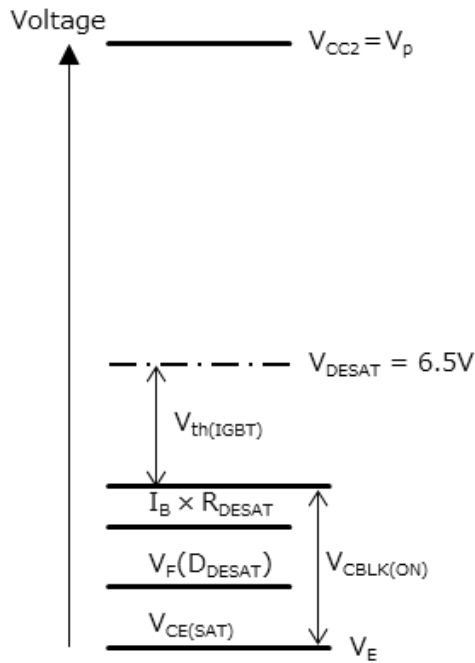

**Figure 4.3 Voltage Chart for DESAT Detection**

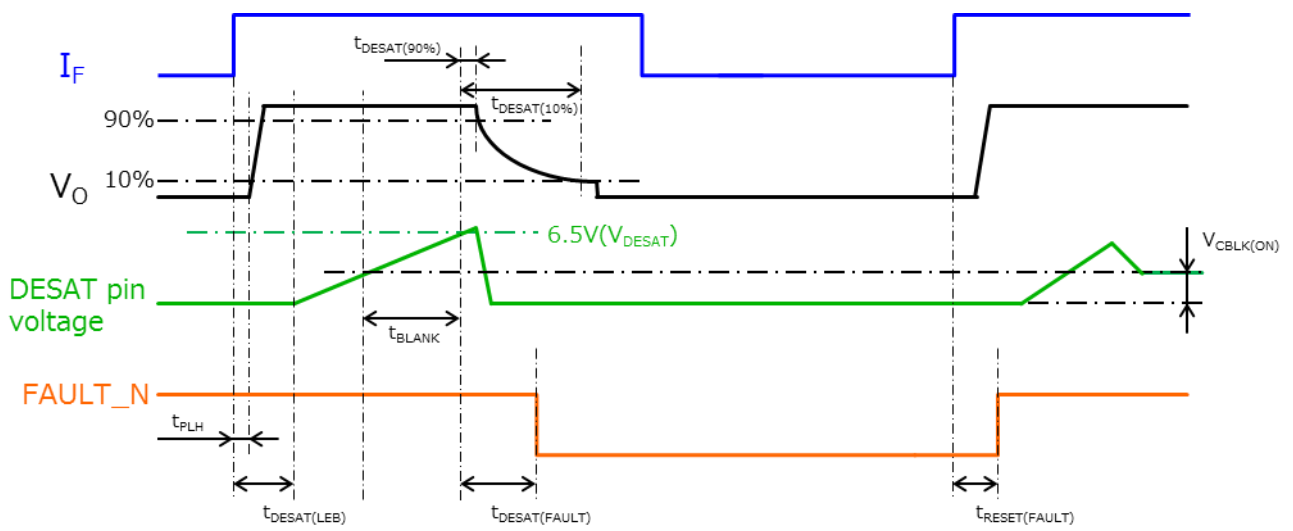

**Figure 4.4 Timing Chart for DESAT Detection of TLP5214A**

## Revision history

Version	Date	Details
Rev.1.0	2019-06-28	Created
Rev.2.0	2022-05-09	Postscript for TLP5212/TLP5222

## Notes on Contents

### 1. Block Diagrams

Some of the functional blocks, circuits, or constants in the block diagram may be omitted or simplified for explanatory purposes.

### 2. Equivalent Circuits

The equivalent circuit diagrams may be simplified or some parts of them may be omitted for explanatory purposes.

### 3. Example computation of circuit constants

Numerical values in the text are provided as an example in order to explain the circuit in an easy-to-understand manner. It is not guaranteed to operate with the values stated.

## Usage Considerations

### Notes on Handling of Products

- (1) The absolute maximum ratings of a semiconductor device are a set of ratings that must not be exceeded, even for a moment.
- (2) Use an appropriate power supply fuse to ensure that a large current does not continuously flow in case of over current and/or IC failure. The usage beyond absolute maximum rating, the mistaken wiring, the unusual pulse noise etc. which are induced from wiring or load are the cause, and may destroy IC. As the result, it may result in emitting smoke and ignition because high current continues flowing into IC. In order to make influence into the minimum, a proper setup of the capacity of a fuse, pre-arcing time, an insertion circuit position, etc. is needed supposing inflow and an outflow of the high current in destruction.

## RESTRICTIONS ON PRODUCT USE

Toshiba Corporation and its subsidiaries and affiliates are collectively referred to as "TOSHIBA". Hardware, software and systems described in this document are collectively referred to as "Product".

- TOSHIBA reserves the right to make changes to the information in this document and related Product without notice.
- This document and any information herein may not be reproduced without prior written permission from TOSHIBA. Even with TOSHIBA's written permission, reproduction is permissible only if reproduction is without alteration/omission.
- Though TOSHIBA works continually to improve Product's quality and reliability, Product can malfunction or fail. Customers are responsible for complying with safety standards and for providing adequate designs and safeguards for their hardware, software and systems which minimize risk and avoid situations in which a malfunction or failure of Product could cause loss of human life, bodily injury or damage to property, including data loss or corruption. Before customers use the Product, create designs including the Product, or incorporate the Product into their own applications, customers must also refer to and comply with (a) the latest versions of all relevant TOSHIBA information, including without limitation, this document, the specifications, the data sheets and application notes for Product and the precautions and conditions set forth in the "TOSHIBA Semiconductor Reliability Handbook" and (b) the instructions for the application with which the Product will be used with or for. Customers are solely responsible for all aspects of their own product design or applications, including but not limited to (a) determining the appropriateness of the use of this Product in such design or applications; (b) evaluating and determining the applicability of any information contained in this document, or in charts, diagrams, programs, algorithms, sample application circuits, or any other referenced documents; and (c) validating all operating parameters for such designs and applications. **TOSHIBA ASSUMES NO LIABILITY FOR CUSTOMERS' PRODUCT DESIGN OR APPLICATIONS.**
- **PRODUCT IS NEITHER INTENDED NOR WARRANTED FOR USE IN EQUIPMENTS OR SYSTEMS THAT REQUIRE EXTRAORDINARILY HIGH LEVELS OF QUALITY AND/OR RELIABILITY, AND/OR A MALFUNCTION OR FAILURE OF WHICH MAY CAUSE LOSS OF HUMAN LIFE, BODILY INJURY, SERIOUS PROPERTY DAMAGE AND/OR SERIOUS PUBLIC IMPACT ("UNINTENDED USE").** Except for specific applications as expressly stated in this document, Unintended Use includes, without limitation, equipment used in nuclear facilities, equipment used in the aerospace industry, lifesaving and/or life supporting medical equipment, equipment used for automobiles, trains, ships and other transportation, traffic signaling equipment, equipment used to control combustions or explosions, safety devices, elevators and escalators, and devices related to power plant. **IF YOU USE PRODUCT FOR UNINTENDED USE, TOSHIBA ASSUMES NO LIABILITY FOR PRODUCT.** For details, please contact your TOSHIBA sales representative or contact us via our website.
- Do not disassemble, analyze, reverse-engineer, alter, modify, translate or copy Product, whether in whole or in part.
- Product shall not be used for or incorporated into any products or systems whose manufacture, use, or sale is prohibited under any applicable laws or regulations.
- The information contained herein is presented only as guidance for Product use. No responsibility is assumed by TOSHIBA for any infringement of patents or any other intellectual property rights of third parties that may result from the use of Product. No license to any intellectual property right is granted by this document, whether express or implied, by estoppel or otherwise.
- **ABSENT A WRITTEN SIGNED AGREEMENT, EXCEPT AS PROVIDED IN THE RELEVANT TERMS AND CONDITIONS OF SALE FOR PRODUCT, AND TO THE MAXIMUM EXTENT ALLOWABLE BY LAW, TOSHIBA (1) ASSUMES NO LIABILITY WHATSOEVER, INCLUDING WITHOUT LIMITATION, INDIRECT, CONSEQUENTIAL, SPECIAL, OR INCIDENTAL DAMAGES OR LOSS, INCLUDING WITHOUT LIMITATION, LOSS OF PROFITS, LOSS OF OPPORTUNITIES, BUSINESS INTERRUPTION AND LOSS OF DATA, AND (2) DISCLAIMS ANY AND ALL EXPRESS OR IMPLIED WARRANTIES AND CONDITIONS RELATED TO SALE, USE OF PRODUCT, OR INFORMATION, INCLUDING WARRANTIES OR CONDITIONS OF MERCHANTABILITY, FITNESS FOR A PARTICULAR PURPOSE, ACCURACY OF INFORMATION, OR NONINFRINGEMENT.**
- Do not use or otherwise make available Product or related software or technology for any military purposes, including without limitation, for the design, development, use, stockpiling or manufacturing of nuclear, chemical, or biological weapons or missile technology products (mass destruction weapons). Product and related software and technology may be controlled under the applicable export laws and regulations including, without limitation, the Japanese Foreign Exchange and Foreign Trade Law and the U.S. Export Administration Regulations. Export and re-export of Product or related software or technology are strictly prohibited except in compliance with all applicable export laws and regulations.
- Please contact your TOSHIBA sales representative for details as to environmental matters such as the RoHS compatibility of Product. Please use Product in compliance with all applicable laws and regulations that regulate the inclusion or use of controlled substances, including without limitation, the EU RoHS Directive. **TOSHIBA ASSUMES NO LIABILITY FOR DAMAGES OR LOSSES OCCURRING AS A RESULT OF NONCOMPLIANCE WITH APPLICABLE LAWS AND REGULATIONS.**