

M4K Group (1)
Application Note
12-bit Analog to Digital Converter
(ADC-B)

Outlines

This application note is a reference material for developing products using the 12-bit analog to digital converter (ADC) function of M4K Group (1).

This document helps the user check operation of the product and develop its program.

Target sample program: ADC_VersionB_UART

Table of Contents

Outlines	1
Table of Contents	2
1. Preface	4
2. Reference Document	4
3. Function to Use	4
4. Target Device	4
5. Operation Confirmation Condition	5
6. Operation of Evaluation Board	5
7. Sample Program	6
7.1. Structure Diagram of Sample Program	6
7.2. Startup Routine	6
7.3. Main Operation	6
7.4. Setting of AIN Channels of ADC	6
7.5. Setting of Interval Time	7
7.6. Output Example of Terminal Software	8
7.6.1. Setting Example of Terminal Software	8
7.7. Operating Flow of Sample Program	9
8. Points to Remember on Handling of Sample Programs	17
9. Revision History	17
RESTRICTIONS ON PRODUCT USE	18

Arm and Keil are registered trademarks of Arm Limited (or its subsidiaries) in the US and/or elsewhere.

All other company names, product names, and service names mentioned herein may be trademarks of their respective companies.

1. Preface

This sample program converts a voltage value generated by a variable resistor using the ADC. And the program can also display the converted digital value on the terminal software.

2. Reference Document

1. Datasheet
TMPM4K Group (1) Datasheet Rev2.0 (Japanese edition)
2. Reference manual
12-bit Analog to Digital Converter (ADC-B) Rev2.0 (Japanese edition)
Asynchronous Serial Communication Circuit (UART-C) Rev3.0 (Japanese edition)
32-bit Timer Event Counter (T32A-B) Rev3.0 (Japanese edition)
3. Application note
M4K Group (1) Application Note Startup (CMSIS System & Clock Configuration) Rev1.0
4. Other reference document
TMPM4KxA Group Peripheral Driver User Manual (Doxygen) V1.0.4.0

3. Function to Use

IP	Channel	Port	Function/Operation mode
Asynchronous Serial Communication Circuit	ch0	PK0 (UT0RXD) PK1 (UT0TXDA)	UART mode
12-bit Analog to Digital Converter	ch14 (Note)	PE4 (AINA14)	AD conversion (Single conversion operation mode)
	ch15 (Note)	PE5 (AINA15)	
32-bit Timer Event Counter	ch0	—	Interval timer

(Note) The ADC channel is the channel which is defined in the sample program.

4. Target Device

The target devices of this application note are as follows;

TMPM4K4FYAUG	TMPM4K4FWAUG	TMPM4K4FUAUG	TMPM4K4FSAUG
TMPM4K4FYAFG	TMPM4K4FWAFG	TMPM4K4FUAFG	TMPM4K4FSAFG
TMPM4K2FYADUG	TMPM4K2FWADUG	TMPM4K2FUADUG	TMPM4K2FSADUG
TMPM4K1FYAUG	TMPM4K1FWAUG	TMPM4K1FUAUG	TMPM4K1FSAUG
			TMPM4K0FSADUG

* This sample program operates on the evaluation board of TMPM4K4FYAUG.

If other function than the TMPM4K4 one is checked, it is necessary that CMSIS Core related files (the startup file and I/O header file) should be changed properly.

Additionally, the name of microcontroller which is set to the project should be changed.

The BSP related file is dedicated to the evaluation board (TMPM4K4FYAUG). If other function than the TMPM4K4 one is checked, the BSP related file should be changed properly.

5. Operation Confirmation Condition

Used microcontroller	TMPM4K4FYAUG
Used board	TMPM4K4 evaluation board (Product of ESP-kikaku Co. Ltd.)
Integrated development environment	IAR Embedded Workbench for ARM 8.22.2
Integrated development environment	Arm® Keil® MDK Version 5.24.2.0
Terminal software	Tera Term V4.96
Sample program	v1.0.0

6. Operation of Evaluation Board

The USB_UART connector should be connected to a PC for communication with the terminal software. The output of the AD converted value is displayed on the terminal software every interval set in the terminal software.

This sample program can use 2 channels of the ADC.
The other input pin of the ADC (PE5) is connected to VDD.

7. Sample Program

7.1. Structure Diagram of Sample Program

The structure diagram of the sample program is shown below.

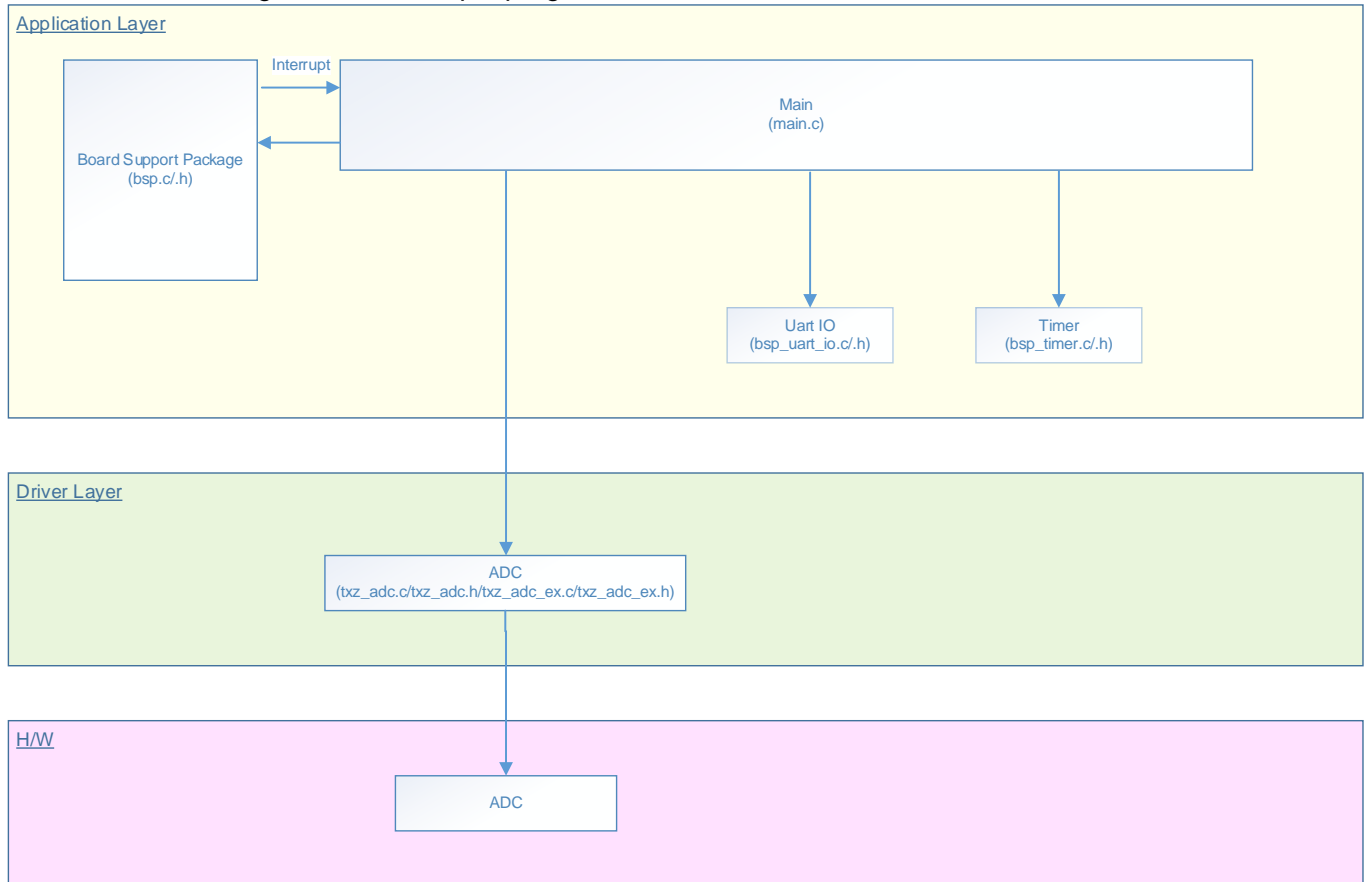

7.2. Startup Routine

The following initialization is done after power is supplied.

The initialization of each clock setting and the initialization of the watchdog timer setting are done.

7.3. Main Operation

The initialization of the BSP is done.

The initialization of the variables is done.

The initialization of the driver is done.

The initialization of the timer, the initialization of the USB_UART, and the initialization of the AD input are done as the initialization of the application software.

The Timer starts.

The input voltage from the ADIN input pin is converted.

The converted result is displayed on the Tera Term via the UART.

7.4. Setting of AIN Channels of ADC

When the used AIN input pin is changed, the following in the bsp.c file should be modified properly.

```

static const uint32_t potentiometersTbl[BSP_POTENTIOMETERS_MAX][4] =
{
    {(uint32_t)GPIO_PORT_E, (uint32_t)GPIO_PORT_4, (uint32_t)(14), (uint32_t)(14)},
    {(uint32_t)GPIO_PORT_E, (uint32_t)GPIO_PORT_5, (uint32_t)(15), (uint32_t)(15)},
};
    
```

The setting of 2 channel inputs of the ADC is available in this sample program as shown above. It, however, should be noted that the only one ADC input is available on the evaluation board in the operation confirmation condition. PE5 is connected to VDD. The input voltage on the PE5 pin is converted to “FFF”.

7.5. Setting of Interval Time

The interval time of the display update of the converted output can be modified by changing CFG_OUTPUT_INTERVAL in the main.c.

```
#define CFG_OUTPUT_INTERVAL          ((uint32_t)5000)
```

When the value “5000” is modified to another proper value, the interval time of the display update is changed.

7.6. Output Example of Terminal Software

When the sample program is executed, the output value of the ADC is displayed. The display is updated frequently (every 5 seconds as default).

```
Convert Result Value[VR1]:0xfff
Convert Result Value[VR2]:0xfff
Convert Result Value[VR1]:0x66f
Convert Result Value[VR2]:0xfff
Convert Result Value[VR1]:0x0
Convert Result Value[VR2]:0xfff
Convert Result Value[VR1]:0x75c
Convert Result Value[VR2]:0xfff
```

7.6.1. Setting Example of Terminal Software

The operation of the terminal software (Tera Term) has been checked with the following settings.

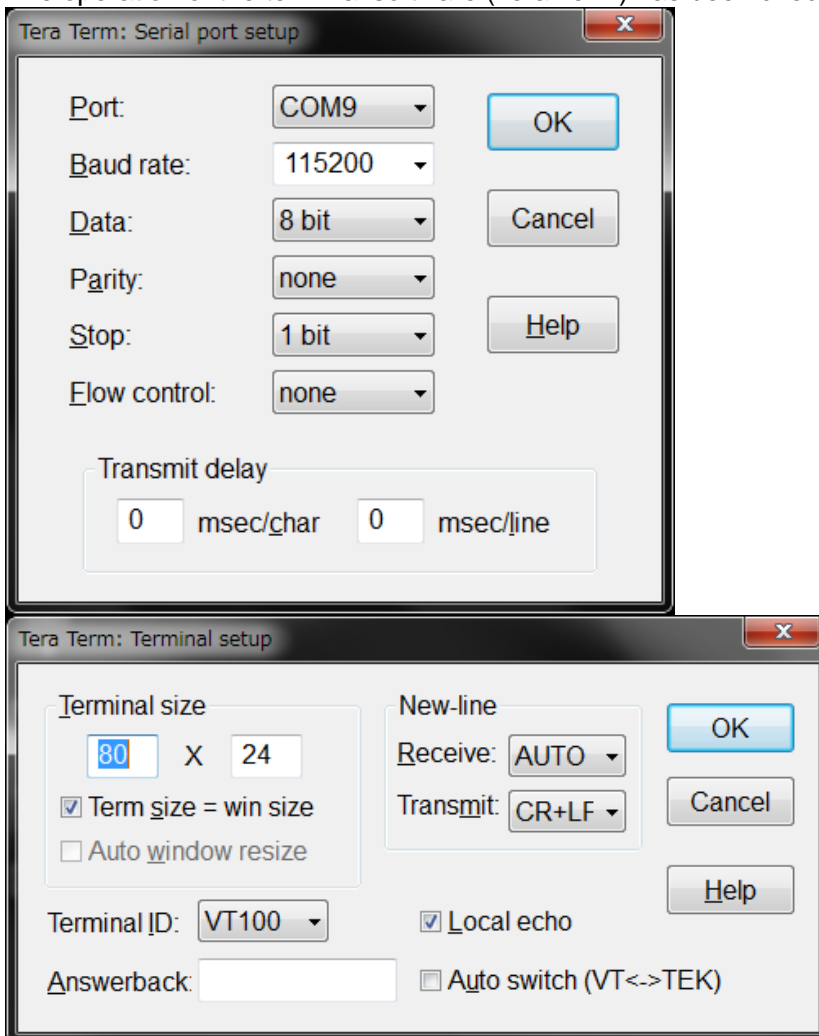

7.7. Operating Flow of Sample Program

The basic operating flows of the sample program are shown in the following;

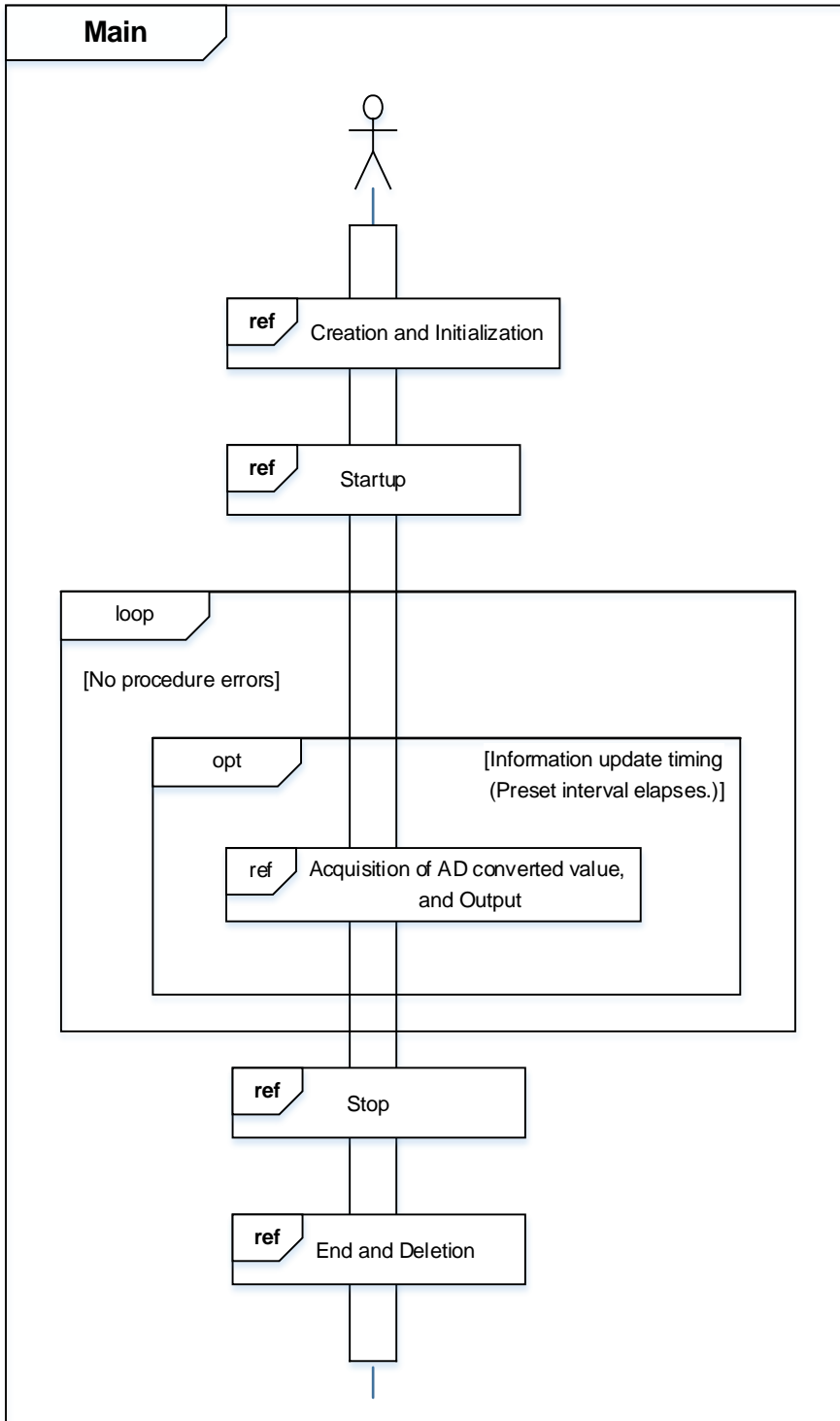

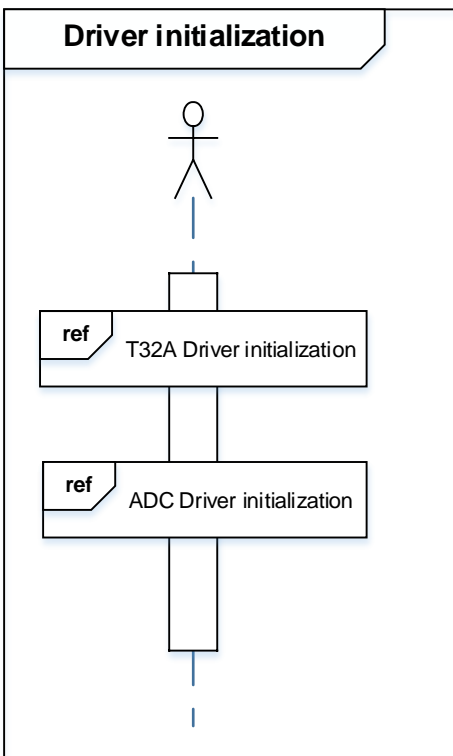
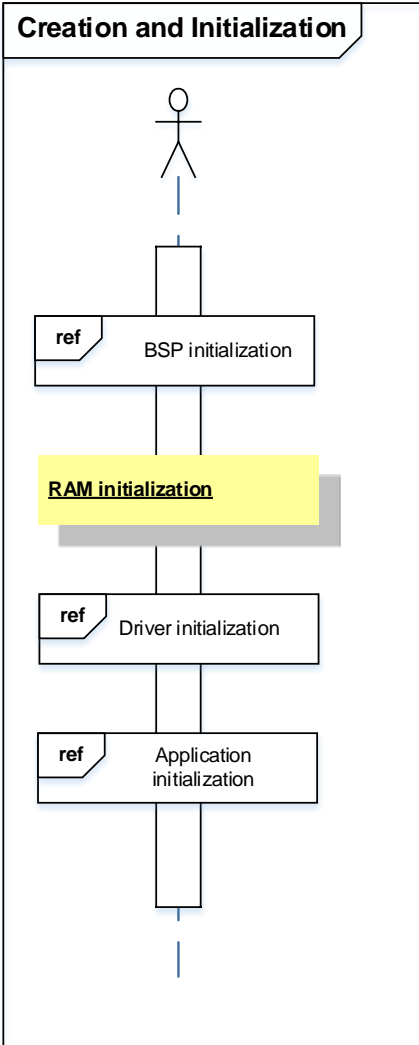

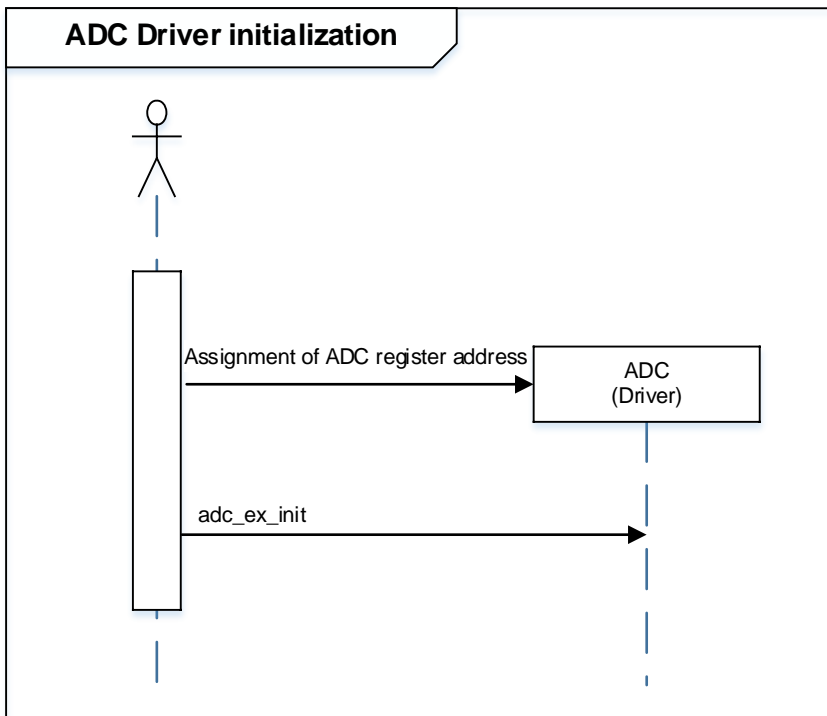
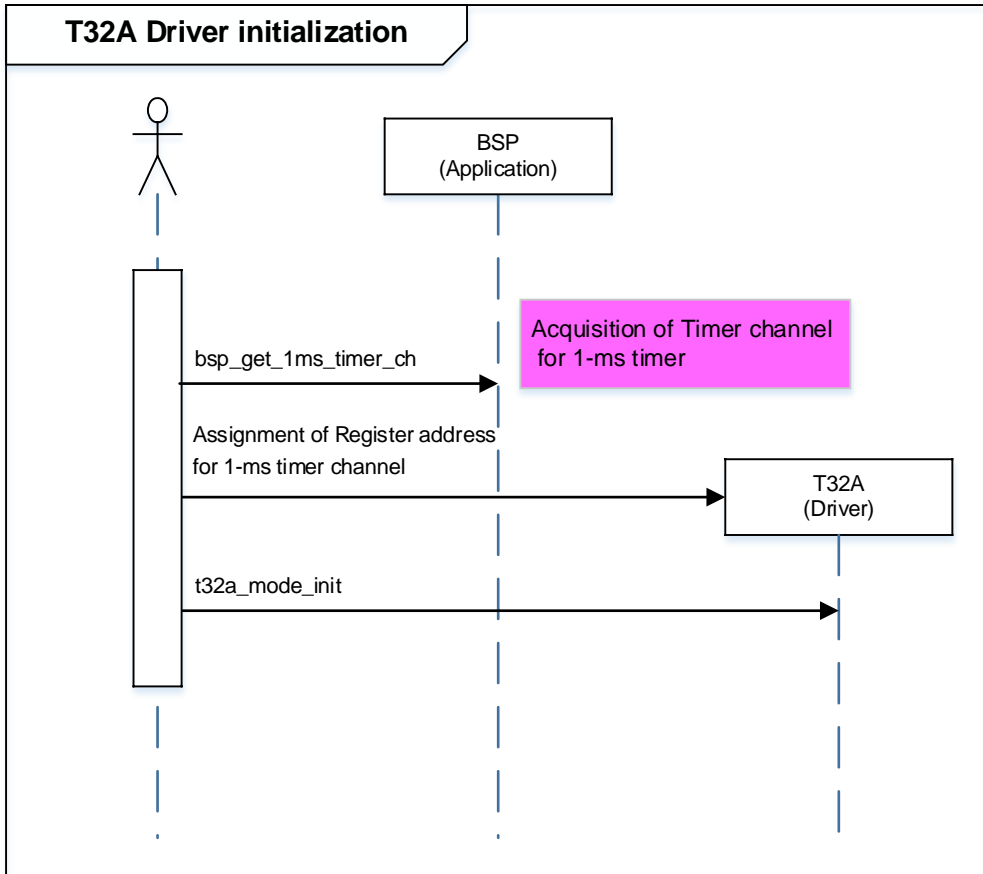

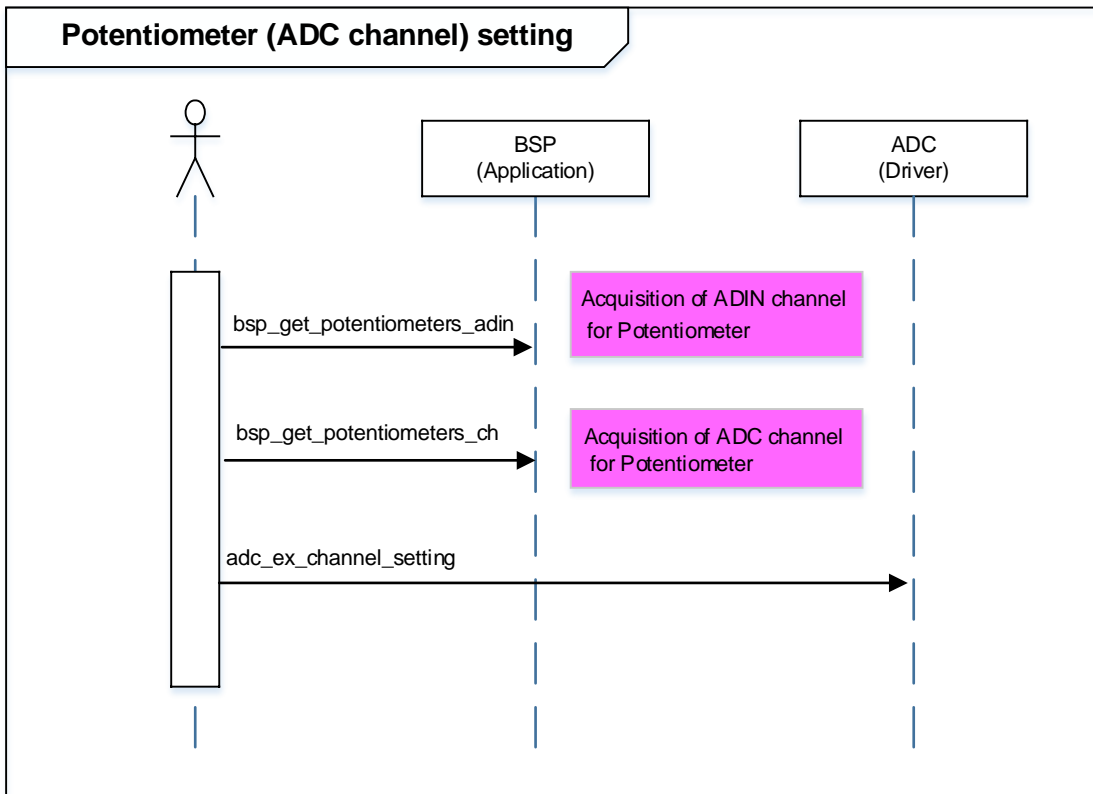
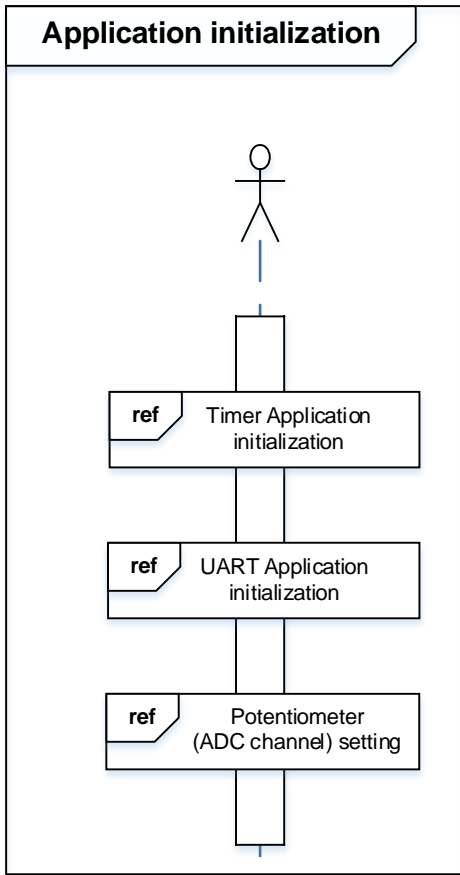

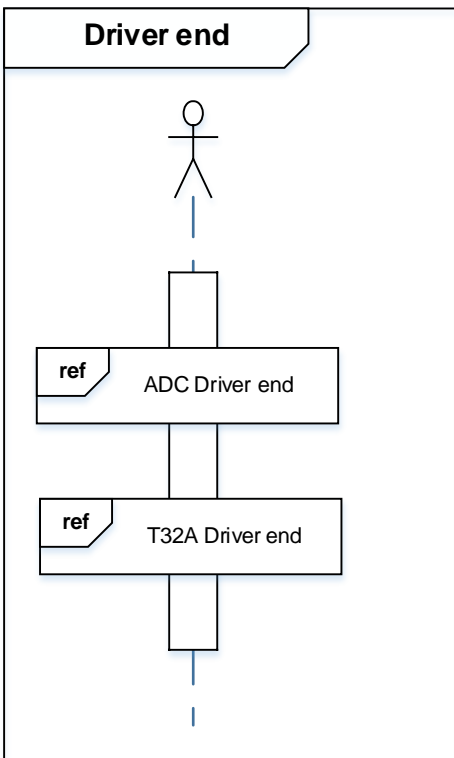
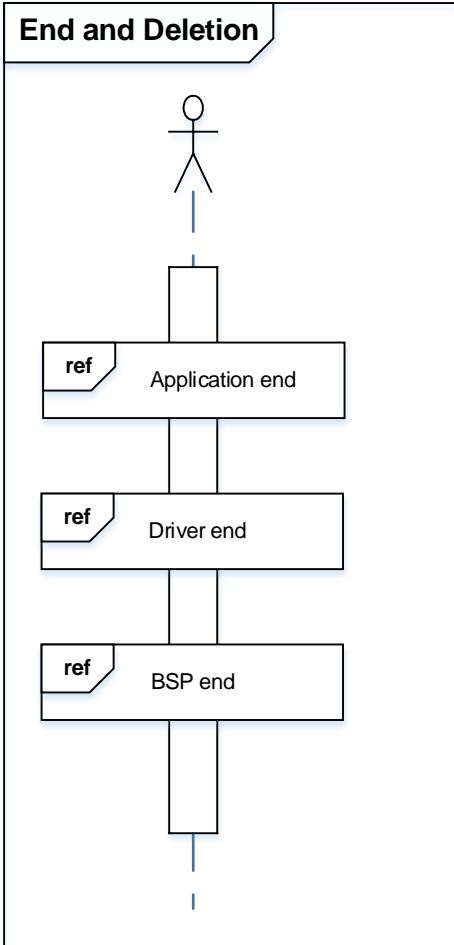

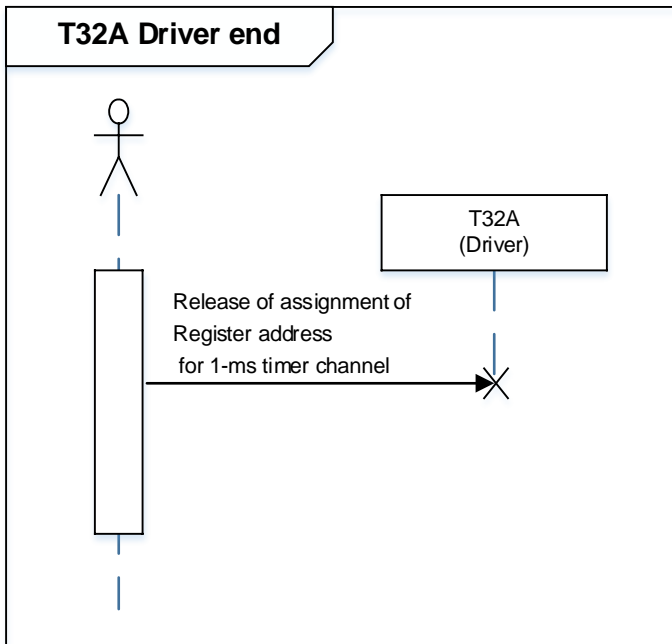
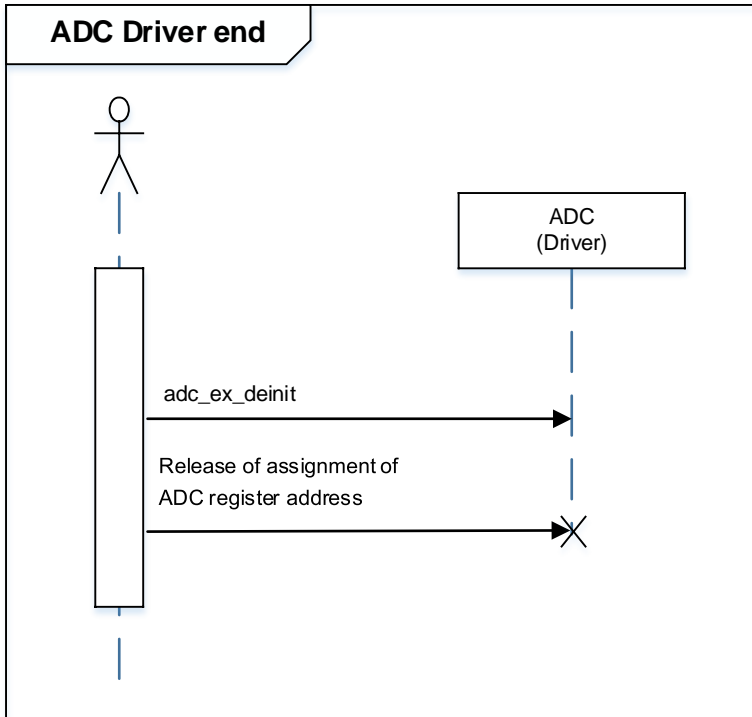

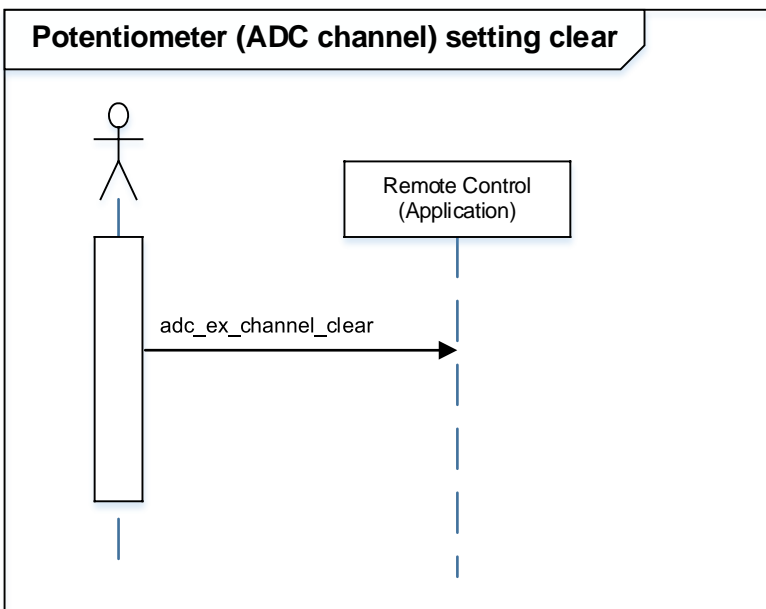
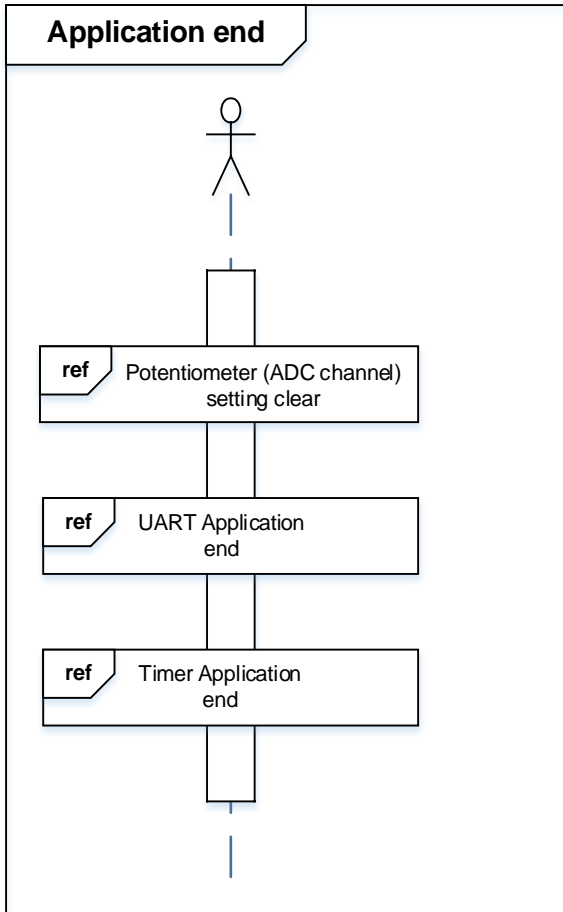

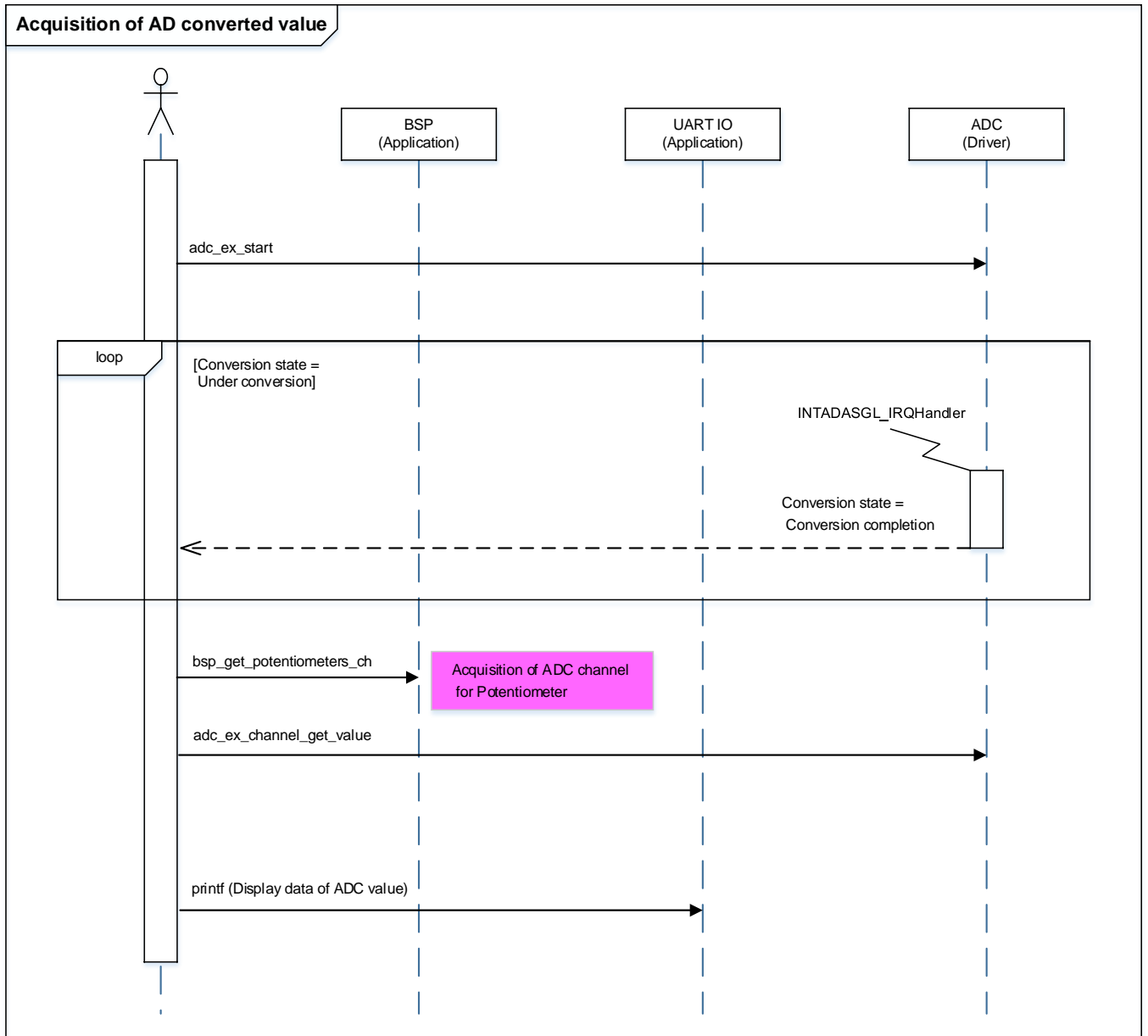

8. Points to Remember on Handling of Sample Programs

When using the sample program with other than “Operation Confirmation Condition”, please check the operation sufficiently.

9. Revision History

Revision	Date	Description
1.0	2019-10-08	First release

RESTRICTIONS ON PRODUCT USE

Toshiba Corporation and its subsidiaries and affiliates are collectively referred to as "TOSHIBA". Hardware, software and systems described in this document are collectively referred to as "Product".

- TOSHIBA reserves the right to make changes to the information in this document and related Product without notice.
- This document and any information herein may not be reproduced without prior written permission from TOSHIBA. Even with TOSHIBA's written permission, reproduction is permissible only if reproduction is without alteration/omission.
- Though TOSHIBA works continually to improve Product's quality and reliability, Product can malfunction or fail. Customers are responsible for complying with safety standards and for providing adequate designs and safeguards for their hardware, software and systems which minimize risk and avoid situations in which a malfunction or failure of Product could cause loss of human life, bodily injury or damage to property, including data loss or corruption. Before customers use the Product, create designs including the Product, or incorporate the Product into their own applications, customers must also refer to and comply with (a) the latest versions of all relevant TOSHIBA information, including without limitation, this document, the specifications, the data sheets and application notes for Product and the precautions and conditions set forth in the "TOSHIBA Semiconductor Reliability Handbook" and (b) the instructions for the application with which the Product will be used with or for. Customers are solely responsible for all aspects of their own product design or applications, including but not limited to (a) determining the appropriateness of the use of this Product in such design or applications; (b) evaluating and determining the applicability of any information contained in this document, or in charts, diagrams, programs, algorithms, sample application circuits, or any other referenced documents; and (c) validating all operating parameters for such designs and applications. **TOSHIBA ASSUMES NO LIABILITY FOR CUSTOMERS' PRODUCT DESIGN OR APPLICATIONS.**
- **PRODUCT IS NEITHER INTENDED NOR WARRANTED FOR USE IN EQUIPMENTS OR SYSTEMS THAT REQUIRE EXTRAORDINARILY HIGH LEVELS OF QUALITY AND/OR RELIABILITY, AND/OR A MALFUNCTION OR FAILURE OF WHICH MAY CAUSE LOSS OF HUMAN LIFE, BODILY INJURY, SERIOUS PROPERTY DAMAGE AND/OR SERIOUS PUBLIC IMPACT ("UNINTENDED USE").** Except for specific applications as expressly stated in this document, Unintended Use includes, without limitation, equipment used in nuclear facilities, equipment used in the aerospace industry, lifesaving and/or life supporting medical equipment, equipment used for automobiles, trains, ships and other transportation, traffic signaling equipment, equipment used to control combustions or explosions, safety devices, elevators and escalators, and devices related to power plant. **IF YOU USE PRODUCT FOR UNINTENDED USE, TOSHIBA ASSUMES NO LIABILITY FOR PRODUCT.** For details, please contact your TOSHIBA sales representative or contact us via our website.
- Do not disassemble, analyze, reverse-engineer, alter, modify, translate or copy Product, whether in whole or in part.
- Product shall not be used for or incorporated into any products or systems whose manufacture, use, or sale is prohibited under any applicable laws or regulations.
- The information contained herein is presented only as guidance for Product use. No responsibility is assumed by TOSHIBA for any infringement of patents or any other intellectual property rights of third parties that may result from the use of Product. No license to any intellectual property right is granted by this document, whether express or implied, by estoppel or otherwise.
- **ABSENT A WRITTEN SIGNED AGREEMENT, EXCEPT AS PROVIDED IN THE RELEVANT TERMS AND CONDITIONS OF SALE FOR PRODUCT, AND TO THE MAXIMUM EXTENT ALLOWABLE BY LAW, TOSHIBA (1) ASSUMES NO LIABILITY WHATSOEVER, INCLUDING WITHOUT LIMITATION, INDIRECT, CONSEQUENTIAL, SPECIAL, OR INCIDENTAL DAMAGES OR LOSS, INCLUDING WITHOUT LIMITATION, LOSS OF PROFITS, LOSS OF OPPORTUNITIES, BUSINESS INTERRUPTION AND LOSS OF DATA, AND (2) DISCLAIMS ANY AND ALL EXPRESS OR IMPLIED WARRANTIES AND CONDITIONS RELATED TO SALE, USE OF PRODUCT, OR INFORMATION, INCLUDING WARRANTIES OR CONDITIONS OF MERCHANTABILITY, FITNESS FOR A PARTICULAR PURPOSE, ACCURACY OF INFORMATION, OR NONINFRINGEMENT.**
- Do not use or otherwise make available Product or related software or technology for any military purposes, including without limitation, for the design, development, use, stockpiling or manufacturing of nuclear, chemical, or biological weapons or missile technology products (mass destruction weapons). Product and related software and technology may be controlled under the applicable export laws and regulations including, without limitation, the Japanese Foreign Exchange and Foreign Trade Law and the U.S. Export Administration Regulations. Export and re-export of Product or related software or technology are strictly prohibited except in compliance with all applicable export laws and regulations.
- Please contact your TOSHIBA sales representative for details as to environmental matters such as the RoHS compatibility of Product. Please use Product in compliance with all applicable laws and regulations that regulate the inclusion or use of controlled substances, including without limitation, the EU RoHS Directive. **TOSHIBA ASSUMES NO LIABILITY FOR DAMAGES OR LOSSES OCCURRING AS A RESULT OF NONCOMPLIANCE WITH APPLICABLE LAWS AND REGULATIONS.**