

TB67H451FNG

Toshiba Adds New Low Power Consumption Brushed DC Motor Driver IC

Toshiba Electronic Devices & Storage Corporation ("Toshiba") has added "TB67H451FNG," to its lineup of low power consumption brushed DC motor driver ICs in the popular pin-assignment HSOP8 package. The new IC features automatic return after over current detection. Mass production shipments start today.

The new IC can drive brushed DC motors with a wide range of power supply from 4.5V to 44V. The numerous applications it supports include mobile devices and devices with 5V USB power supply, and industrial devices, home appliances, printers, and banking terminals that require a high power drive of up to 3.5A^[Note 1].

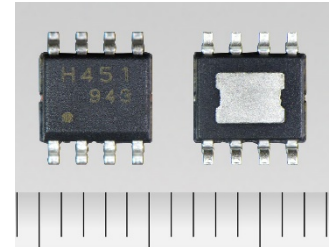

Over current detection is a safety function that prevents damage to the IC by turning off output when the output current exceeds the threshold level due to an overload or other reason. While the current "TC67H450FNG" is a latch type device, where output is turned off indefinitely until the power is recycled or the standby mode is reasserted, "TC67H451FNG" has an auto return function that resumes the operation without any external control. When the over current condition subsides, operation returns to normal. More suitable type can be selected by application.

Three features

- Wide range of operating voltages: 4.5V to 44V for large-current drive devices
- Error detection with auto return (Thermal shutdown, over current detection)
- Low standby current consumption: 1 μ A (max)@VM=24V, Ta=25°C

Applications

Industrial equipment, including OA equipment and banking terminals; small home appliances, including robot vacuum cleaners; battery powered devices (electronic locks and small household robots); and devices using 5V USB power supplies

[Note 1]: Actual driven motor current depends on the use environment and such factors as ambient temperature and power supply voltage

Product specifications

Part number	TB67H450FNG	TB67H451FNG (New)
Supply voltage (operating range)	4.5V to 44V	
Output voltage/current (Absolute maximum rating)	50V / 3.5A	
Package	HSOP8 (Size: 4.9 mm×6.0 mm) (Note1)	
Safety function	Thermal shut down (auto return) Under voltage lockout	
	Over current detection (Latch operation)	Over current detection (auto return)

Note1: HSOP8 package

"TB67H450FNG(O,EL)" and "TB67H451FNG(O,EL)" have different E-PAD shapes.

The mass production of "TB67H450FNG(O,N,EL)" (P-HSOP8-0405-1.27-002 package) also starts.

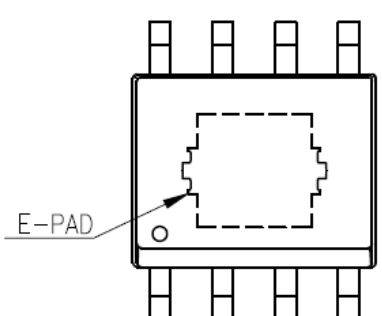
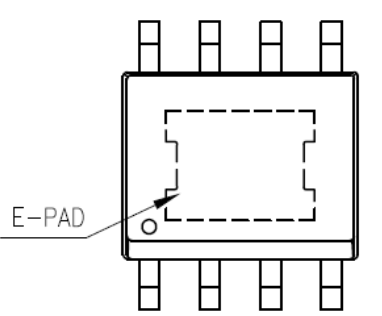
Part number	TB67H450FNG(O,EL)	TB67H451FNG(O,EL) TB67H450FNG(O,N,EL)
Package name	P-HSOP8-0405-1.27-001	P-HSOP8-0405-1.27-002 (Note2)
E-PAD		

Note2: Typical package is P-HSOP8-0405-1.27-002.

Package Dimension

P-HSOP8-0405-1.27-002

Unit: mm

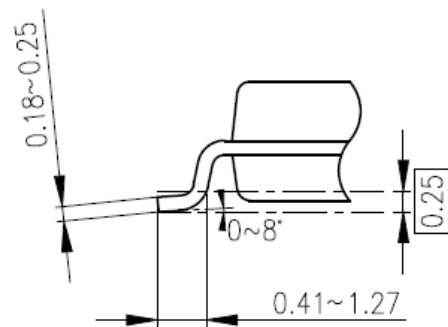
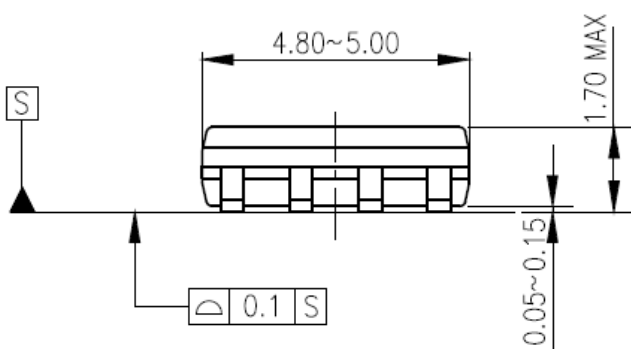
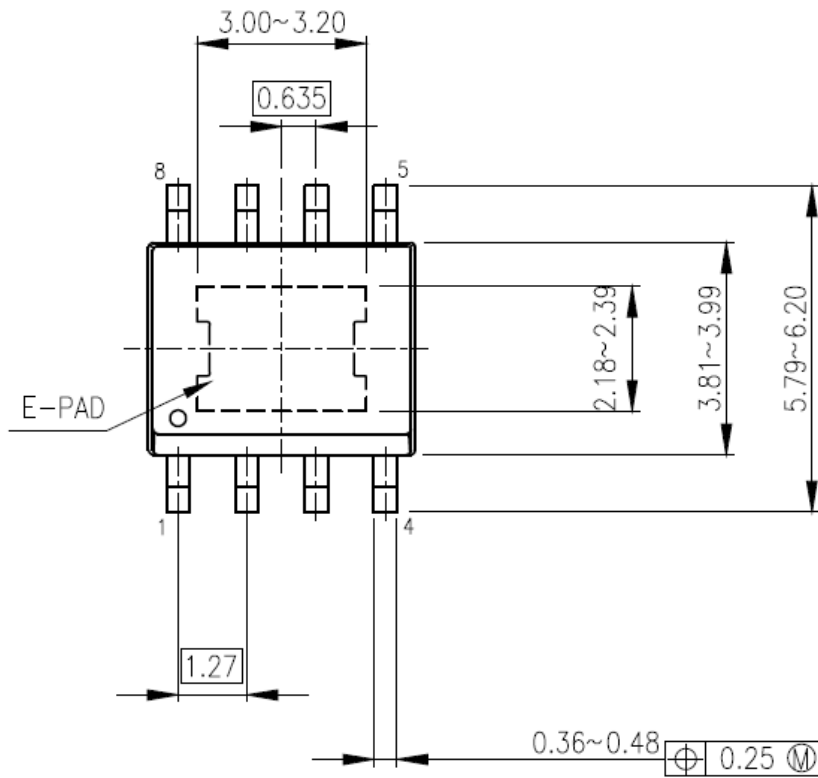

Application Circuit Example

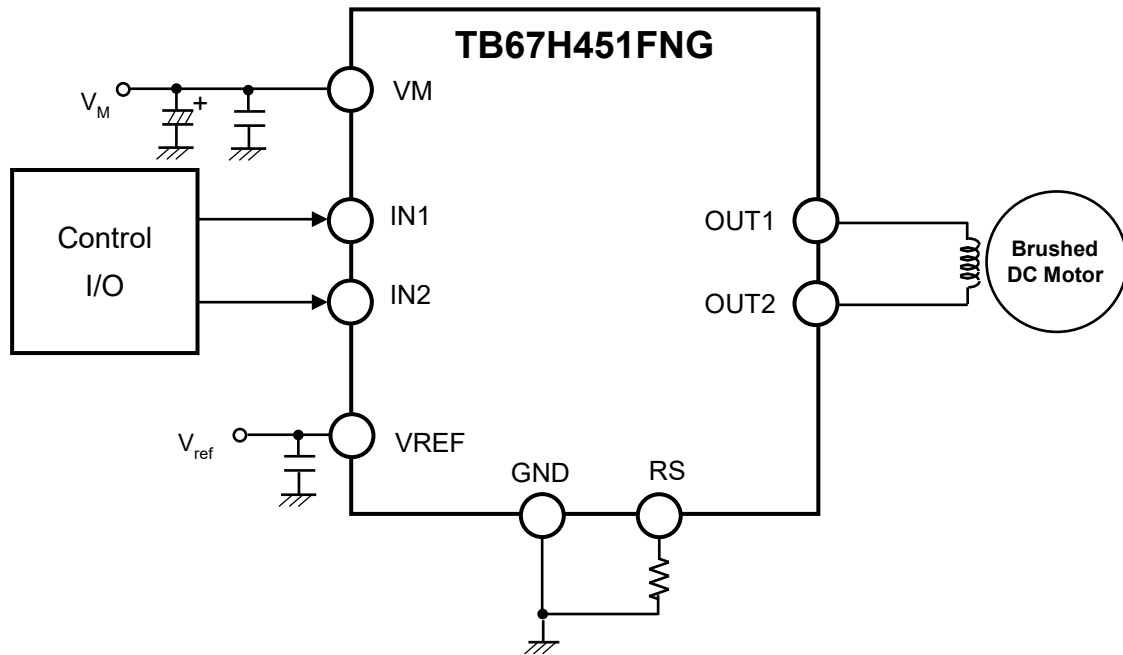

Note: The application circuits shown in this document are provided for reference purposes only. Thorough evaluation is required, especially at the mass production design stage. Providing these application circuit examples does not grant any license for industrial property rights.

Before creating and producing designs and using, customers must also refer to and comply with the latest versions of all relevant information of this document and the instructions for the application that Product will be used with or for.