

Example of low current consumption Operational Amplifiers (Op Amps) to dust sensor

Overview

Sensors are required to have low power consumption, especially on IoT equipment, etc. This document describes the designing of dust sensors using the low current consumption operational amplifiers TC75S102F, TC75S103F. It is useful for designing sensors for use in familiar home appliances such as air conditioners and air purifiers.

Table of Contents

1.	Introduction.....	3
2.	Dust Sensor Specifications	4
2.1.	Dust Sensor Specifications	4
2.2.	Dust sensor	4
3.	Circuit design.....	5
3.1.	Dust Sensor LED Drive Circuit	5
3.2.	Dust Sensor Signal Detection and Amplification Circuit.....	6
4.	Operation result.....	8
4.1.	Evaluation waveform.....	8
5.	Bill of materials	9
5.1.	Bill of Materials.....	9
6.	Related Links.....	10
7.	RESTRICTIONS ON PRODUCT USE.....	11

1. Introduction

The dust sensors described are used in air cleaners, air conditioners, ventilators, vacuum cleaners, environmental monitors, etc. Dust generally affects human health such as allergy, and it affects the quality of products in factories. The dust sensor detects soil particles in the room such as PM2.5, pollen and cigarette smoke, bedding and dust by cleaning, and particles suspended in the air. In industrial applications, it is also used to detect dust in clean rooms such as factories that produce semiconductors and food factories.

This section describes the design of a dust sensor that optically detects dust using Infrared emitting diode (IR LED) and photodetectors.

For detailed information on the low quiescent current and low power op amps TC75S102F and TC75S103F used in this application note, refer to the data sheet of the link.

To download the datasheet for TC75S102F →

[Click Here](#)

To download the datasheet for TC75S103F →

[Click Here](#)

2. Dust Sensor Specifications

2.1. Dust Sensor Specifications

Table 2.1 shows the specifications of the dust sensor.

Table 2.1 Dust sensor specifications

Item	Specifications
Power supply voltage	3.3V
Current consumption	Approx. 300 μ A (Typ. @LED drive Duty5%)
Dust sensor	Scattered-light detector by IR LED and Photodiode
LED emission wavelength	900nm
Operational Amplifier	Toshiba Device & Storage TC75S102F and TC75103F

2.2. Dust sensor

Figure 2.1 shows the block diagram of the dust sensor.

Figure 2.1 Dust Sensor Block Diagram

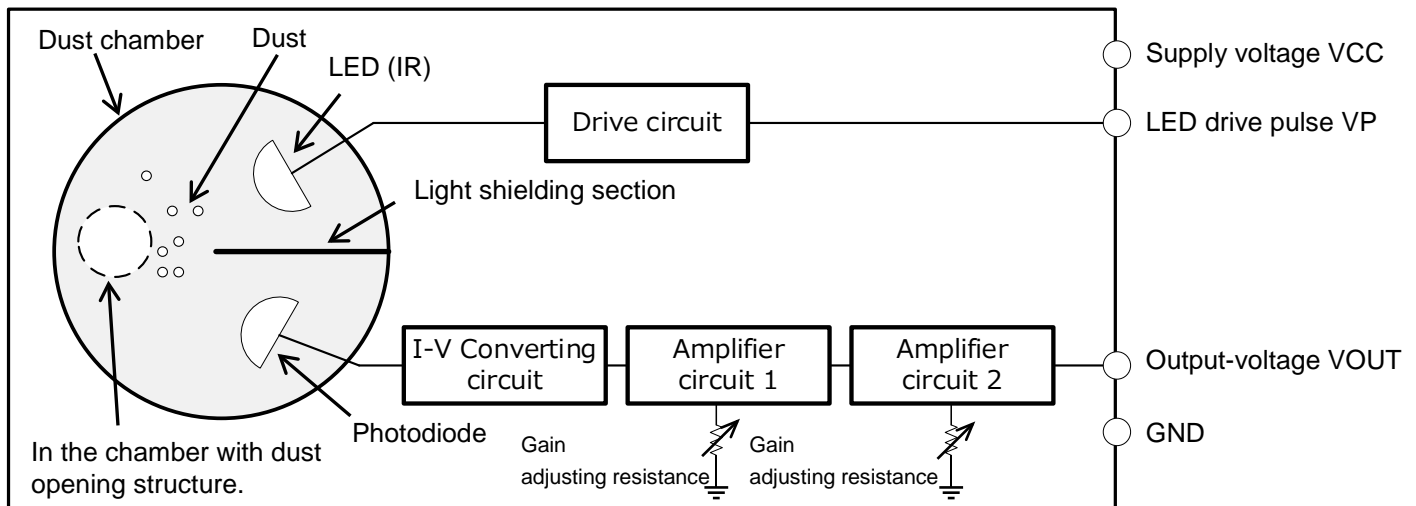

The dust sensor described uses scattered light to detect dust. The dust sensor consists of an LED, photodiode, LED drive circuit, I-V (current-voltage) conversion circuit, and two amplifier circuits. In addition, the dust chamber for collecting dust with an opening structure for dust to enter.

To prevent infrared light emitted from the LED (IR) from entering the photodiode directly, a light shielding section is provided between the LED and the photodiode. When dust enters the chamber, the infrared light emitted from the LED is scattered by the dust. The scattered light is detected by a photodiode. Since the sensing current of the photodiode due to the detection of infrared light is as small as a few micro amperes, it is converted into a voltage by the I-V converting circuit, and this voltage is amplified and output by the two amplifier circuit.

3. Circuit design

This section describes the dust sensor circuit.

3.1. Dust Sensor LED Drive Circuit

Figure 3.1 shows the LED drive circuit of the dust sensor. LED1 is an infrared light-LED. The current I_{LED1} that flows through LED1 can be calculated from the following equation.

$$VCC = VF(LED) + V_{ce(sat)} \times I_{LED1} + R1 \times I_{LED1} \dots \dots (1)$$

VCC shows the supply voltage and VF(LED) show the voltage in the forward direction of the LED, and Vce(sat) shows the saturated voltage of Tr1.

When VCC=3.3V, VF(LED)≐1.3V, Vce(sat)≐0.2V, and R1=1kΩ, I_{LED1} is ≐2mA.

Fig.3.1 Dust Sensor LED Drive Circuit

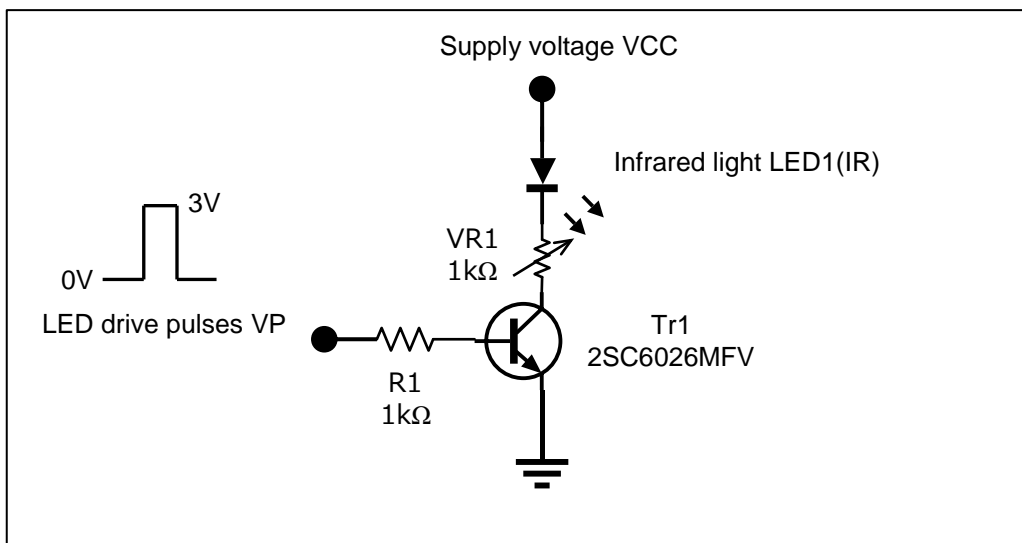

3.2. Dust Sensor Signal Detection and Amplification Circuit

Figure 3.2 shows the signal detection and amplification circuit for the dust sensor.

Fig.3.2 Signal Detection and Amplification Circuit of dust sensor

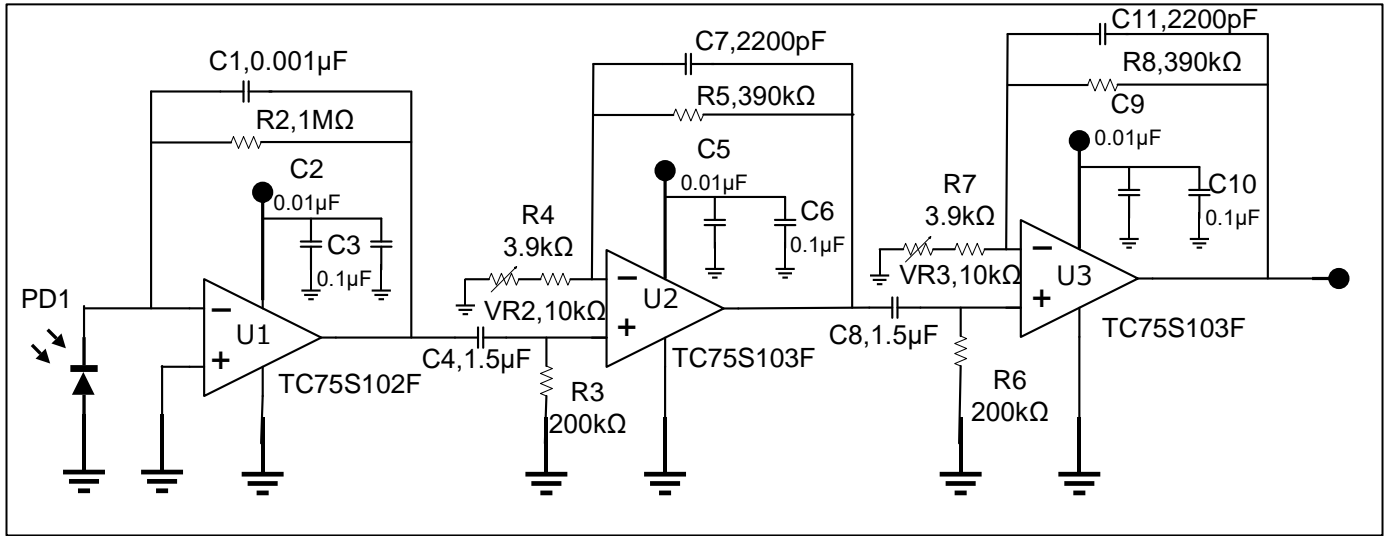

The first stage circuit converts the output current of the photodiode PD1 to I-V (current-voltage). The output current of the photodiode is converted to voltage by op amps U1 and R2. R2 and C1 constitute a low pass filter to prevent oscillation of the operational amplifier.

The following equation calculates the cutoff frequency f_{c1} of the low pass filter (LPF) in the first stage.

$$f_{c1} = \frac{1}{(2 \times \pi \times R2 \times C1)} = \frac{1}{(2 \times \pi \times 1M \times 0.001\mu)} \cong 160Hz \dots \dots (2)$$

$$R2:1M\Omega, C1:0.001 \mu F$$

The output voltage V_{OUT2} from the first stage circuit can be shown below, the electromotive current of the photodiode is I_L .

$$V_{OUT2} = I_L \times R2 \dots \dots (3)$$

C4 and R3 constitute a high pass filter (HPF). This circuit is used to eliminate noise in the low frequency region from the I-V conversion circuit in the first stage circuit. For the cutoff frequency f_{c2} of HPFs,

$$f_{c2} = \frac{1}{(2 \times \pi \times R3 \times C4)} = \frac{1}{(2 \times \pi \times 200k \times 1.5\mu)} \cong 0.53Hz \dots \dots (4)$$

$$R3:200k\Omega, C4:1.5 \mu F$$

The second stage amplifier circuit also amplifies the signal of the photodiode converted to a voltage. R4, VR2

and R5 determine the gain of this amplifier. VR2 adjusts the gain GV1 of the amplifier. This circuit also has an LPF composed of R5 and C7 to eliminate unnecessary frequency signals and prevent oscillation of the operational amplifier circuit. The gain GV1 and the cutoff frequency fc3 of the LPF are as follows:

$$GV1 = \left[1 + \left\{ \frac{R5}{(R4 + VR2)} \right\} \right] = 1 + \frac{390k}{3.9k} \cong 101 \text{times} \cdot \cdot \cdot \cdot (5)$$

R5: 390kΩ, R4:3.9kΩ, VR2:10kΩ (calculated as 0Ω in the above equation)

$$fc3 = \frac{1}{(2 \times \pi \times R5 \times C7)} = \frac{1}{(2 \times \pi \times 390k \times 2200p)} \cong 185Hz \cdot \cdot \cdot \cdot (6)$$

The third stage amplification circuit further amplifies the signal of the photodiode amplified by the second stage amplification circuit. The circuit configuration is the same as that of the second stage amplifier circuit. The HPF is composed of C8 and R6. For the cutoff frequency fc4 of HPF.

$$fc4 = \frac{1}{(2 \times \pi \times R6 \times C8)} = \frac{1}{(2 \times \pi \times 200k \times 1.5\mu)} \cong 0.53Hz \cdot \cdot \cdot \cdot (7)$$

R6:200kΩ, C8:1.5 μF

R7 and VR3 and R8 determine the gain GV2 of the amplifier. C11 and R8 also constitute LPFs with cut-off frequency fc5.

$$GV2 = \left[1 + \left\{ \frac{R8}{(R7 + VR3)} \right\} \right] = 1 + \frac{390k}{3.9k} \cong 101 \text{times} \cdot \cdot \cdot \cdot (8)$$

R8: 390 kΩ, R7:3.9kΩ, VR3:10kΩ (calculated as 0 Ω in the above equation)

$$fc5 = \frac{1}{(2 \times \pi \times R8 \times C11)} = \frac{1}{(2 \times \pi \times 390k \times 2200p)} \cong 185Hz \cdot \cdot \cdot \cdot (6)$$

Therefore, the output voltage of the first stage is 101×101≈10,200 times as large as that of the second stage (GV=101 times) and the third stage (101 times).

For each op amps, 0.01μF/0.1μF is connected in parallel to the power supply pin as a bypass capacitor. Connect a capacitor with the smallest ESR possible to the power supply terminal of the op-amp as close as possible.

4. Operation result

The evaluation results of this dust sensor are described below.

4.1. Evaluation waveform

Indicates the input/output waveform of the dust sensor. In the absence of dust, the photodiode does not detect light because the infrared light from the LEDs in the dust chamber does not scatter, so the output-voltage from the dust sensor is 0V (Fig.4.1).

When there is dust, the light from the LED is scattered by the dust and the photodiode detects the light. For this reason, a voltage corresponding to the dust is output from the dust sensor at the same timing as the drive pulse that causes the LED to light(Fig.4.2).

Fig.4.1 Input / output waveform of dust sensor (There is no dust)

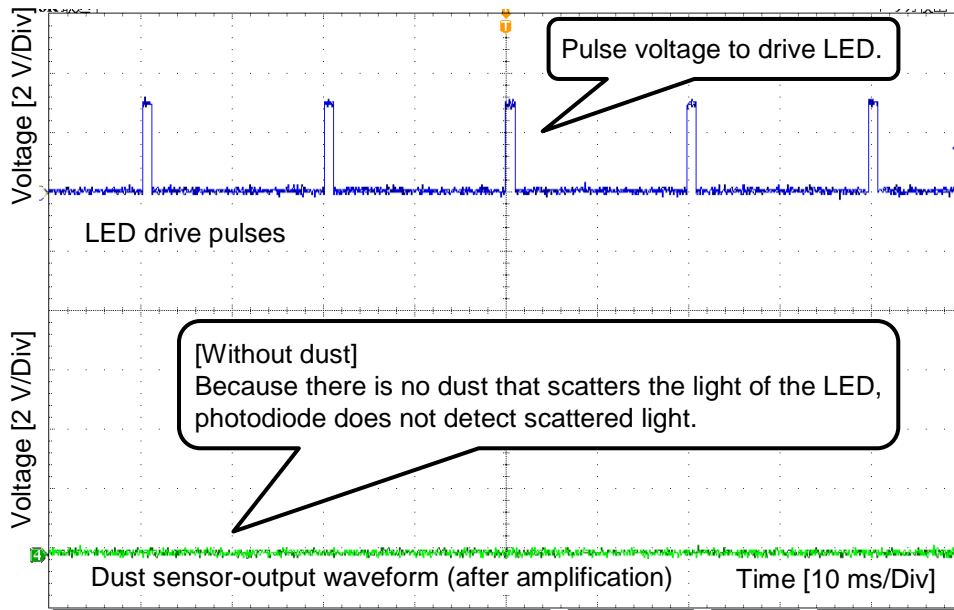
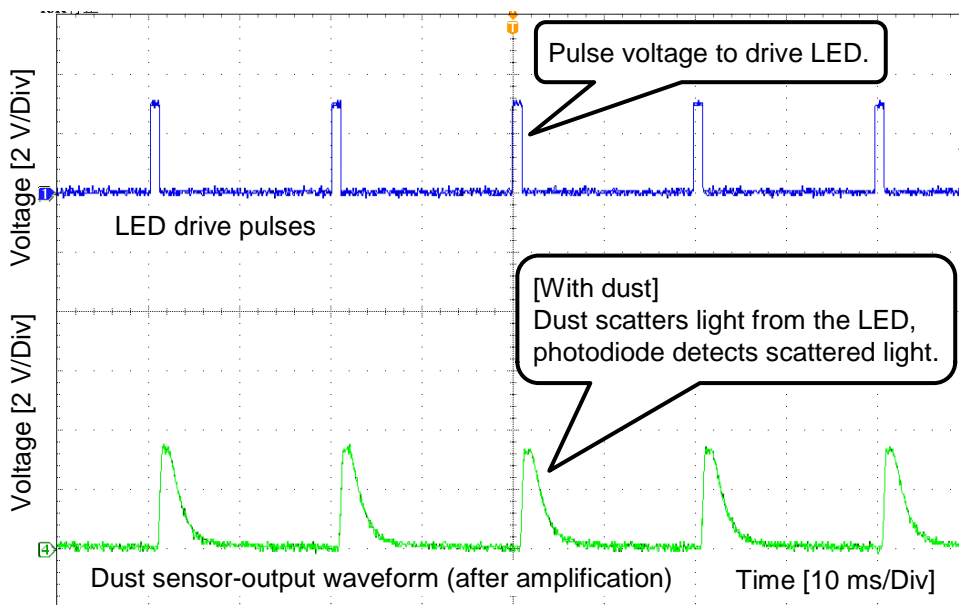

Fig.4.2 Input / output waveform of dust sensor (There is dust)



5. Bill of materials

5.1. Bill of Materials

Table 5.1 Bill of Materials

Item	Parts	Quantity	Value	Part name	Manufacturer	Description
1	U1	1	-	TC75S102F	TOSHIBA	Operational amplifier
2	U2, U3	2	-	TC75S103F	TOSHIBA	Operational amplifier
3	LED1	1	-	-	-	IR LED
4	PD1	1	-	-	-	Photodiode
5	Tr1	1	-	2SC6026MFV	TOSHIBA	Transistor
6	R1	1	1kΩ	-	-	1/4W, ±1%
7	C1	1	0.001μF	-	-	Ceramic Capacitor, 6.3V, ±10%
8	C2,C5,C9	3	0.01μF	-	-	Ceramic Capacitor, 6.3V, ±10%
9	C3,C6,C10	3	0.1μF	-	-	Ceramic Capacitor, 6.3V, ±10%
10	VR1	1	1kΩ	-	-	Potentiometer, 100 mW
11	VR2,VR3	2	10kΩ	-	-	Potentiometer, 100 mW
12	R3,R6	2	200kΩ	-	-	1/4W, ±1%
13	R4,R7	2	3.9kΩ	-	-	1/4W, ±1%
14	R5,R8	2	390kΩ	-	-	1/4W, ±1%
15	C4,C8	2	1.5μF	-	-	Ceramic, 6.3V, ±10%

6. Related Links

■ Product Line Ups (Catalog)

[Click](#)

■ Product Line Ups (Detail)

[Click](#)

■ Line Ups of Bipolar ICs (Parametric search)

[Click](#)

■ Stock check & Purchase (Bipolar ICs)



■ Line Ups of CMOS ICs (Parametric search)

[Click](#)

■ Stock check & Purchase (CMOS ICs)



■ FAQ of Opams & Comparators

[Click](#)

■ Application Notes

[Click](#)

7. RESTRICTIONS ON PRODUCT USE

Toshiba Corporation and its subsidiaries and affiliates are collectively referred to as "TOSHIBA".

Hardware, software and systems described in this document are collectively referred to as "Product".

- TOSHIBA reserves the right to make changes to the information in this document and related Product without notice.
- This document and any information herein may not be reproduced without prior written permission from TOSHIBA. Even with TOSHIBA's written permission, reproduction is permissible only if reproduction is without alteration/omission.
- Though TOSHIBA works continually to improve Product's quality and reliability, Product can malfunction or fail. Customers are responsible for complying with safety standards and for providing adequate designs and safeguards for their hardware, software and systems which minimize risk and avoid situations in which a malfunction or failure of Product could cause loss of human life, bodily injury or damage to property, including data loss or corruption. Before customers use the Product, create designs including the Product, or incorporate the Product into their own applications, customers must also refer to and comply with (a) the latest versions of all relevant TOSHIBA information, including without limitation, this document, the specifications, the data sheets and application notes for Product and the precautions and conditions set forth in the "TOSHIBA Semiconductor Reliability Handbook" and (b) the instructions for the application with which the Product will be used with or for. Customers are solely responsible for all aspects of their own product design or applications, including but not limited to (a) determining the appropriateness of the use of this Product in such design or applications; (b) evaluating and determining the applicability of any information contained in this document, or in charts, diagrams, programs, algorithms, sample application circuits, or any other referenced documents; and (c) validating all operating parameters for such designs and applications. TOSHIBA ASSUMES NO LIABILITY FOR CUSTOMERS' PRODUCT DESIGN OR APPLICATIONS.
- PRODUCT IS NEITHER INTENDED NOR WARRANTED FOR USE IN EQUIPMENTS OR SYSTEMS THAT REQUIRE EXTRAORDINARILY HIGH LEVELS OF QUALITY AND/OR RELIABILITY, AND/OR A MALFUNCTION OR FAILURE OF WHICH MAY CAUSE LOSS OF HUMAN LIFE, BODILY INJURY, SERIOUS PROPERTY DAMAGE AND/OR SERIOUS PUBLIC IMPACT ("UNINTENDED USE"). Except for specific applications as expressly stated in this document, Unintended Use includes, without limitation, equipment used in nuclear facilities, equipment used in the aerospace industry, lifesaving and/or life supporting medical equipment, equipment used for automobiles, trains, ships and other transportation, traffic signaling equipment, equipment used to control combustions or explosions, safety devices, elevators and escalators, and devices related to power plant. IF YOU USE PRODUCT FOR UNINTENDED USE, TOSHIBA ASSUMES NO LIABILITY FOR PRODUCT. For details, please contact your TOSHIBA sales representative or contact us via our website.
- Do not disassemble, analyze, reverse-engineer, alter, modify, translate or copy Product, whether in whole or in part.
- Product shall not be used for or incorporated into any products or systems whose manufacture, use, or sale is prohibited under any applicable laws or regulations.
- The information contained herein is presented only as guidance for Product use. No responsibility is assumed by TOSHIBA for any infringement of patents or any other intellectual property rights of third parties that may result from the use of Product. No license to any intellectual property right is granted by this document, whether express or implied, by estoppel or otherwise.
- ABSENT A WRITTEN SIGNED AGREEMENT, EXCEPT AS PROVIDED IN THE RELEVANT TERMS AND CONDITIONS OF SALE FOR PRODUCT, AND TO THE MAXIMUM EXTENT ALLOWABLE BY LAW, TOSHIBA (1) ASSUMES NO LIABILITY WHATSOEVER, INCLUDING WITHOUT LIMITATION, INDIRECT, CONSEQUENTIAL, SPECIAL, OR INCIDENTAL DAMAGES OR LOSS, INCLUDING WITHOUT LIMITATION, LOSS OF PROFITS, LOSS OF OPPORTUNITIES, BUSINESS INTERRUPTION AND LOSS OF DATA, AND (2) DISCLAIMS ANY AND ALL EXPRESS OR IMPLIED WARRANTIES AND CONDITIONS RELATED TO SALE, USE OF PRODUCT, OR INFORMATION, INCLUDING WARRANTIES OR CONDITIONS OF MERCHANTABILITY, FITNESS FOR A PARTICULAR PURPOSE, ACCURACY OF INFORMATION, OR NONINFRINGEMENT.
- Do not use or otherwise make available Product or related software or technology for any military purposes, including without limitation, for the design, development, use, stockpiling or manufacturing of nuclear, chemical, or biological weapons or missile technology products (mass destruction weapons). Product and related software and technology may be controlled under the applicable export laws and regulations including, without limitation, the Japanese Foreign Exchange and Foreign Trade Law and the U.S. Export Administration Regulations. Export and re-export of Product or related software or technology are strictly prohibited except in compliance with all applicable export laws and regulations.
- Please contact your TOSHIBA sales representative for details as to environmental matters such as the RoHS compatibility of Product. Please use Product in compliance with all applicable laws and regulations that regulate the inclusion or use of controlled substances, including without limitation, the EU RoHS Directive. TOSHIBA ASSUMES NO LIABILITY FOR DAMAGES OR LOSSES OCCURRING AS A RESULT OF NONCOMPLIANCE WITH APPLICABLE LAWS AND REGULATIONS.

Toshiba Electronic Devices & Storage Corporation

<https://toshiba.semicon-storage.com/>