

Toshiba BiCD Process Integrated Circuit Silicon Monolithic

TB67S539FTG

BiCD Constant-Current Two-Phase Bipolar Stepping Motor Driver IC

1. Description

The TB67S539FTG is a two-phase bipolar stepping motor driver using a PWM chopper.

Fabricated with the BiCD process, the TB67S539FTG is rated at 40 V/2.0 A (Absolute maximum ratings).

A stepping motor can be operated with a single VM power supply by built-in regulator.

Weight: 0.066 g (typ.)

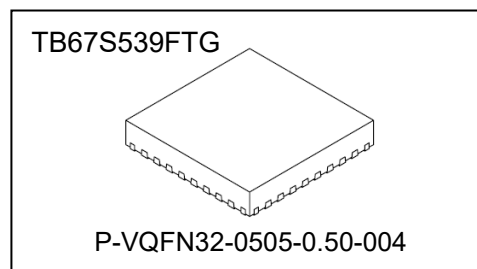

Weight: 0.066 g (typ.)

2. Features

- BiCD process monolithic IC.
- Capable of controlling bipolar stepping motor.
- Advanced Current Detect System (ACDS) realizes a PWM constant-current control without external current detection resistors.
- Advanced Dynamic Mixed Decay (ADMD) realizes a high efficiency PWM constant-current control.
- Clock input control.
- Operational in full, half, quarter, 1/8, 1/16, and 1/32 step resolutions.
- BiCD process: Use DMOSFET for the output power transistor.
- High withstand voltage and large current drive: 40 V / 2.0 A (Absolute maximum ratings).
- Built-in thermal shutdown (TSD), over-current detection (ISD), and under voltage lockout (UVLO).
- External components for a charge pump are reduced.
- Package: QFN32 (5 mm × 5 mm).

3. Block Diagram

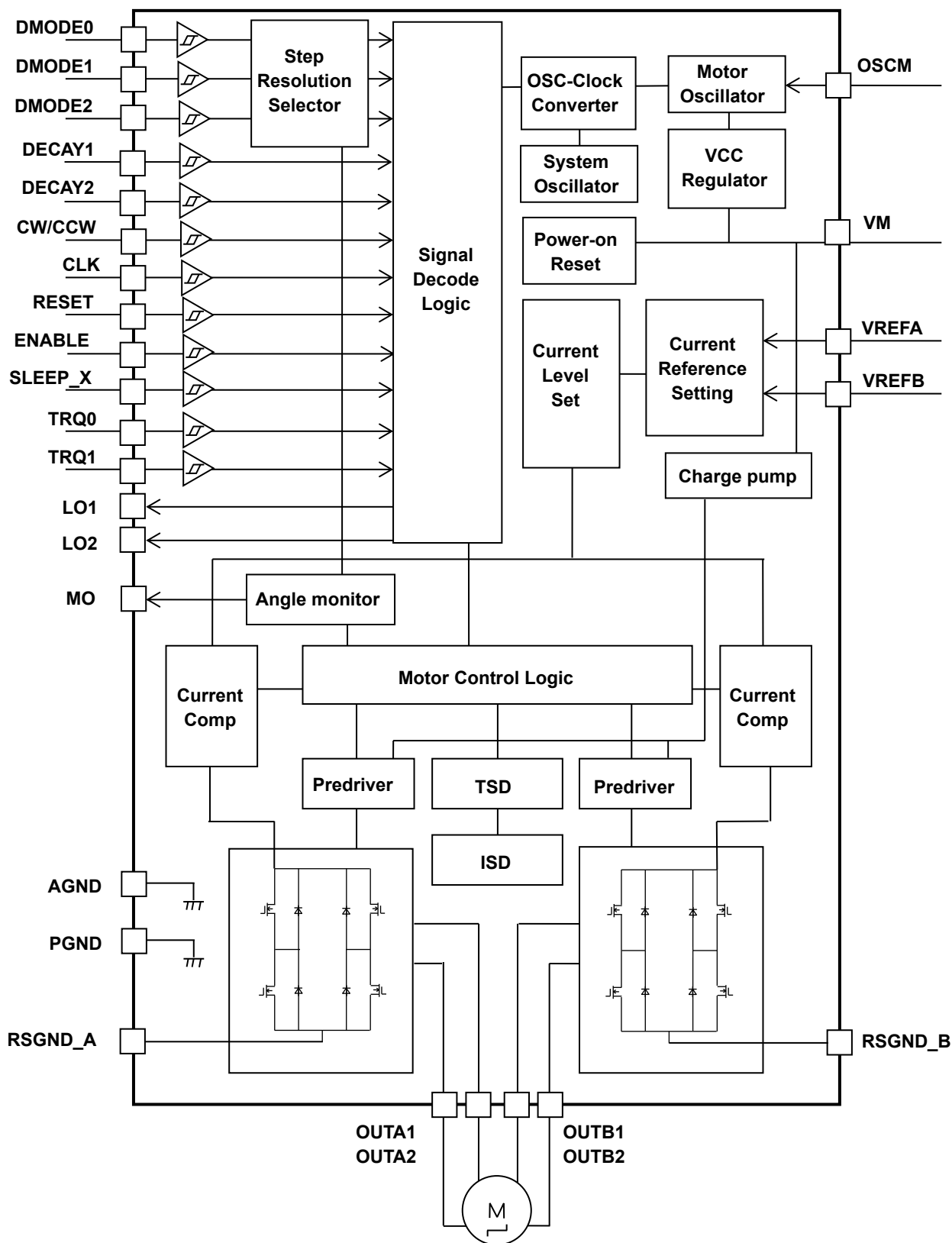

Figure 3.1 Block Diagram

Note: Some of the functional blocks, circuits, or constants in the block diagram may be omitted or simplified for explanatory purposes.

Note: All the grounding wires of the TB67S539FTG should run on the solder mask on the PCB and be externally terminated at only one point. Also, a grounding method should be considered for efficient heat dissipation. Careful attention should be paid to the layout of the output, VM and GND traces, to avoid short circuits across output pins or to the power supply or ground. If such a short circuit occurs, the device may be permanently damaged. Also, the utmost care should be taken for pattern designing and implementation of the device since it has power supply pins (VM, OUTA1, OUTA2, OUTB1, OUTB2, AGND, PGND, RSGND_A, and RSGND_B) through which a particularly large current may run. If these pins are wired incorrectly, an operation error may occur or the device may be destroyed. The logic input pins must also be wired correctly. Otherwise, the device may be damaged owing to a current running through the IC that is larger than the specified current. Careful attention should be paid to design patterns and mountings.

4. Pin Assignments

(Top View)

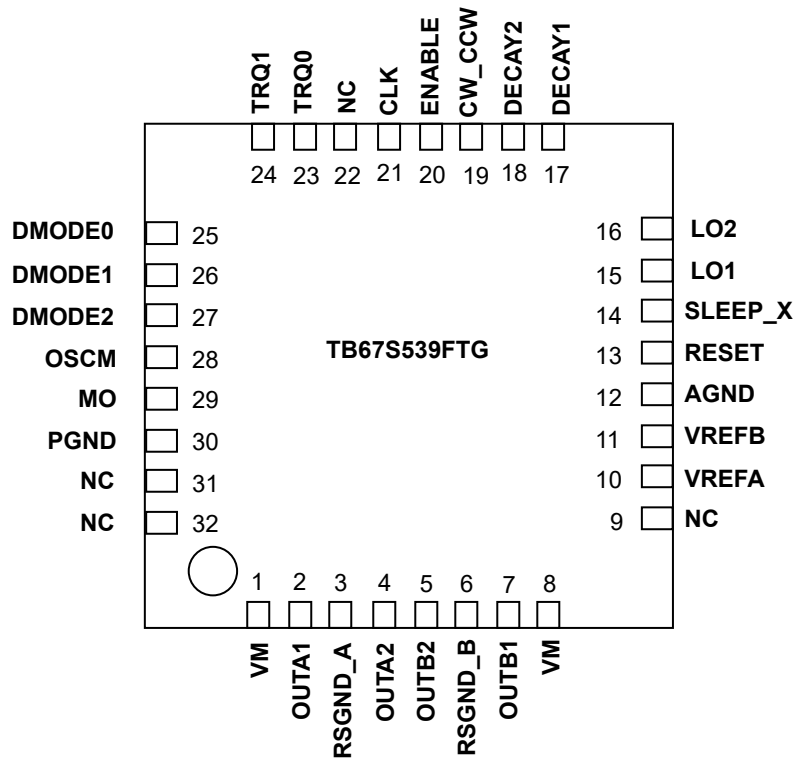

Figure 4.1 Pin Assignments

5. Pin Description

5.1. Pin Function Description TB67S539FTG

Table 5.1 Pin Function Description

Pin number	Pin name	Function
1	VM	VM voltage input pin
2	OUTA1	Motor A ch output pin
3	RSGND_A	Motor A ch GND pin
4	OUTA2	Motor A ch output pin
5	OUTB2	Motor B ch output pin
6	RSGND_B	Motor B ch GND pin
7	OUTB1	Motor B ch output pin
8	VM	VM voltage input pin
9	NC	Non connection
10	VREFA	A ch output current threshold reference pin
11	VREFB	B ch output current threshold reference pin
12	AGND	GND pin
13	RESET	RESET signal input pin. The electrical angle is initialized.
14	SLEEP_X	SLEEP signal input pin
15	LO1	Reset signal output pin at error detection
16	LO2	Reset signal output pin at error detection
17	DECAY1	Constant-current chopping control change pin
18	DECAY2	Constant-current chopping control change pin
19	CW_CCW	Rotation direction change pin
20	ENABLE	ENABLE signal input pin. A ch and B ch motor output ON/OFF control pin
21	CLK	Clock signal input pin. The electrical angle leads at a rising edge.
22	NC	Non connection
23	TRQ0	Torque change pin
24	TRQ1	Torque change pin
25	DMODE0	Step resolution setting pin
26	DMODE1	Step resolution setting pin
27	DMODE2	Step resolution setting pin
28	OSCM	Resistor connection pin for OSCM setting
29	MO	Electrical angle monitor pin
30	PGND	Motor output GND pin
31	NC	Non connection
32	NC	Non connection

Note: NC pins should be set open.

5.2. Input and Output Equivalent Circuit

Table 5.2 Input and Output Equivalent Circuit

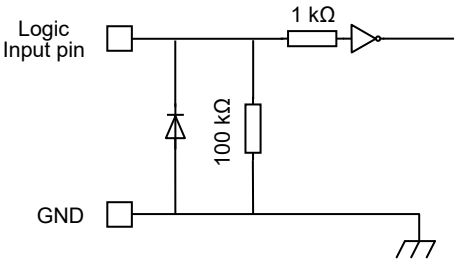
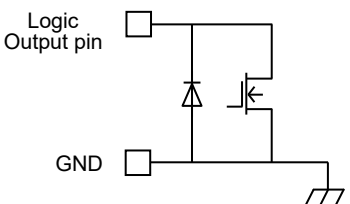
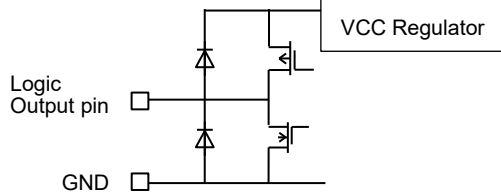
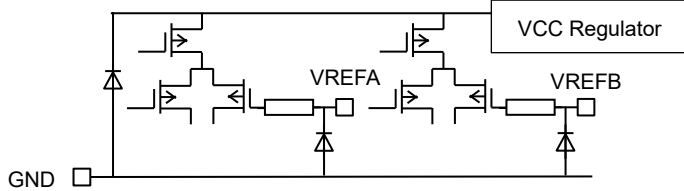
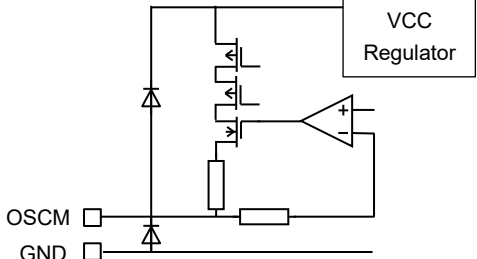
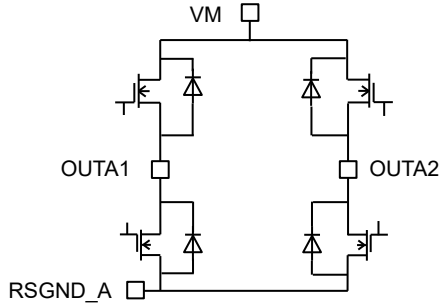
端子名称	等価回路
CLK, ENABLE RESET, CW/CCW DMODE0, DMODE1 DMODE2, TRQ0 TRQ1, SLEEP_X DECAY1, DECAY2	
MO LO1	
LO2	
VREFA VREFB	
OSCM	
VM OUTA1 OUTA2 OUTB1 OUTB2 RSGND_A RSGND_B	 <p>Note: Same as OUTB1 and OUTB2</p>

Note: The equivalent circuit diagrams may be simplified or some parts of them may be omitted for explanatory purposes.

6. Functional Description: TB67S539FTG

6.1. SLEEP_X function

The operation can resume from the output forced off state, which is configured by the thermal shutdown detection (TSD) and the over-current detection (ISD), by setting SLEEP mode once and then setting the normal operation mode again. The SLEEP_X pin is set to Low, and SLEEP mode is set after 100 μ s. The SLEEP_X pin is set to High, and normal mode resumes after 10 ms(Max).

Table 6.1 SLEEP_X function

SLEEP_X	Function
L	SLEEP mode (Charge pump stop, and VCC Reg stop)
H	Normal operation

6.2. CLK function

Each up-edge of the CLK signal shifts the current step and electrical angle of the motor.

Table 6.2 CLK function

CLK	Function
↑	Shifts the electrical angle and current step per each up-edge.
↓	- (Holds the former state)

6.3. ENABLE function

The ENABLE pin controls the ON and OFF of the stepping motor outputs. The normal constant-current control is started by switching ON. In the setting of switching OFF, the MOSFET is OFF and the output becomes high impedance state.

Table 6.3 ENABLE function

ENABLE	Function
H	Output MOSFET operation: ON (Normal operation)
L	Output MOSFET operation: OFF (operation stop and high impedance state)

6.4. CW/CCW function

The CW/CCW pin controls the rotation direction of the stepping motor.

Table 6.4 CW/CCW function

CW/CCW	Function
H	Forward rotation (CW)
L	Reverse rotation (CCW)

6.5. DMODE0, DMODE1, and DMODE2 functions

The DMODE pins are used to set the step resolution for stepping motor operation.

Table 6.5 DMODE0, DMODE1, and DMODE2 functions

DMODE0	DMODE1	DMODE2	Function
L	L	L	Full step resolution setting
L	L	H	Half step resolution (a) setting
L	H	L	Half step resolution (b) setting
L	H	H	Quarter step resolution setting
H	L	L	1/8 step resolution setting
H	L	H	1/16 step resolution setting
H	H	L	1/32 step resolution setting
H	H	H	1/32 step resolution setting

6.6. Sequence in each drive mode: Clock input control mode

6.6.1. Full step resolution setting

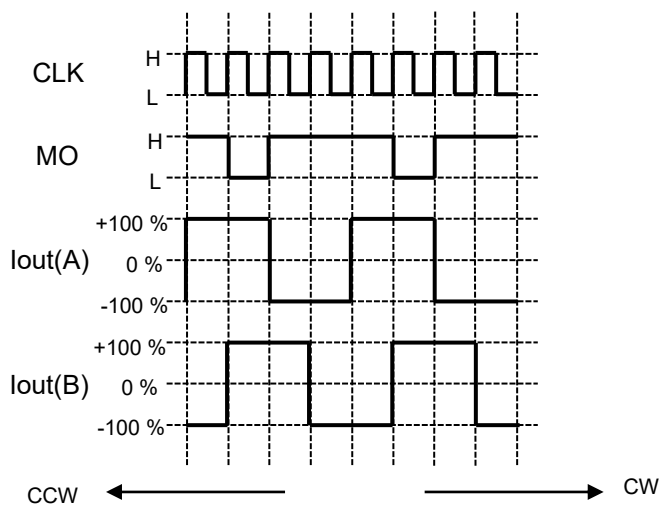

Figure 6.1 Full step resolution setting

6.6.2. Half step resolution (a) setting

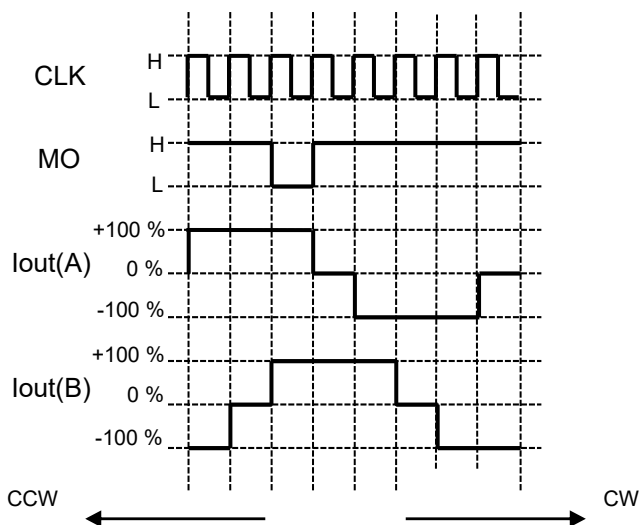

Figure 6.2 Half step resolution (a) setting

Waveform of MO output: State of pull-up.

Note: Timing charts may be simplified for explanatory purpose.

6.6.3. Half step resolution (b) setting

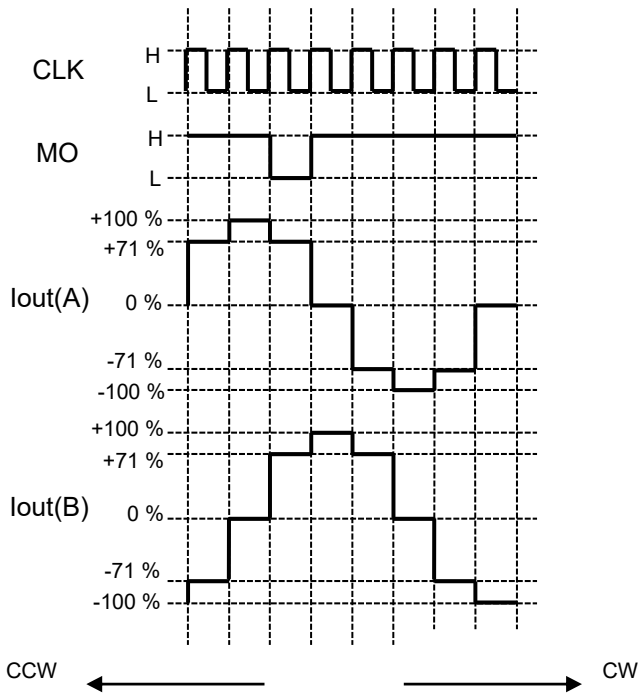

Figure 6.3 Half step resolution (b) setting

6.6.4. Quarter step resolution setting

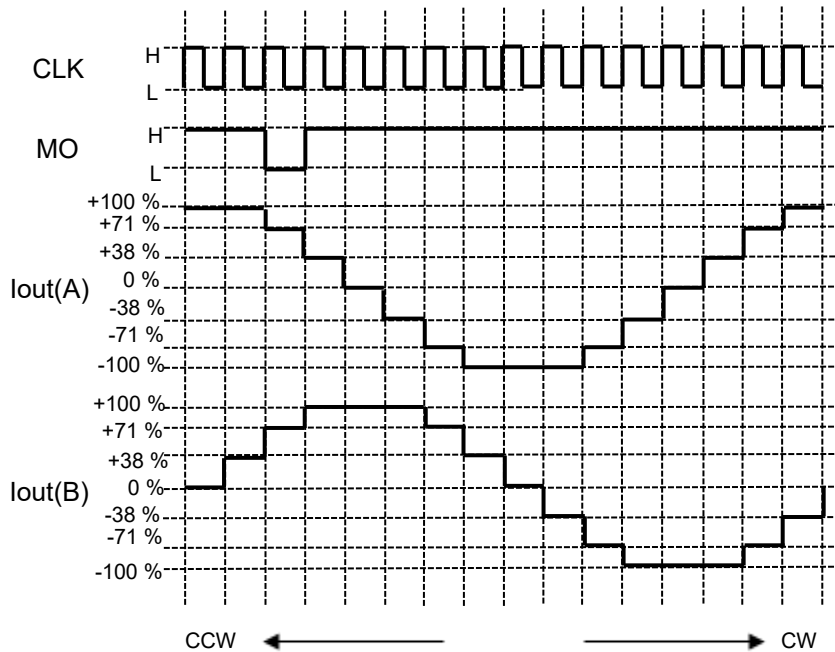

Figure 6.4 Quarter step resolution setting

Waveform of MO output: State of pull-up.

Note: Timing charts may be simplified for explanatory purpose.

6.6.5. 1/8 step resolution setting

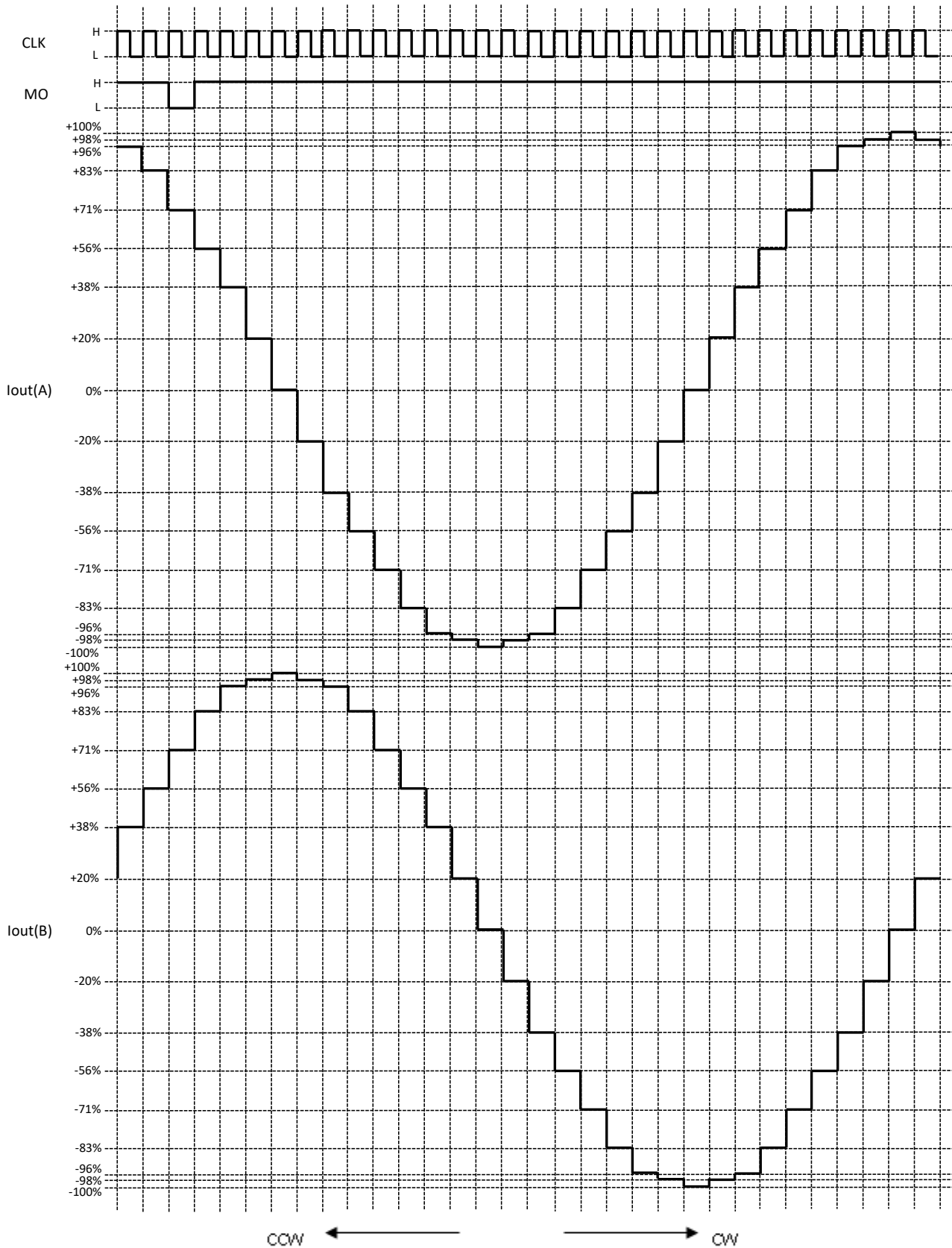

Figure 6.5 1/8 step resolution setting

Waveform of MO output: State of pull-up.

Note: Timing charts may be simplified for explanatory purpose.

6.6.6. 1/16 step resolution setting

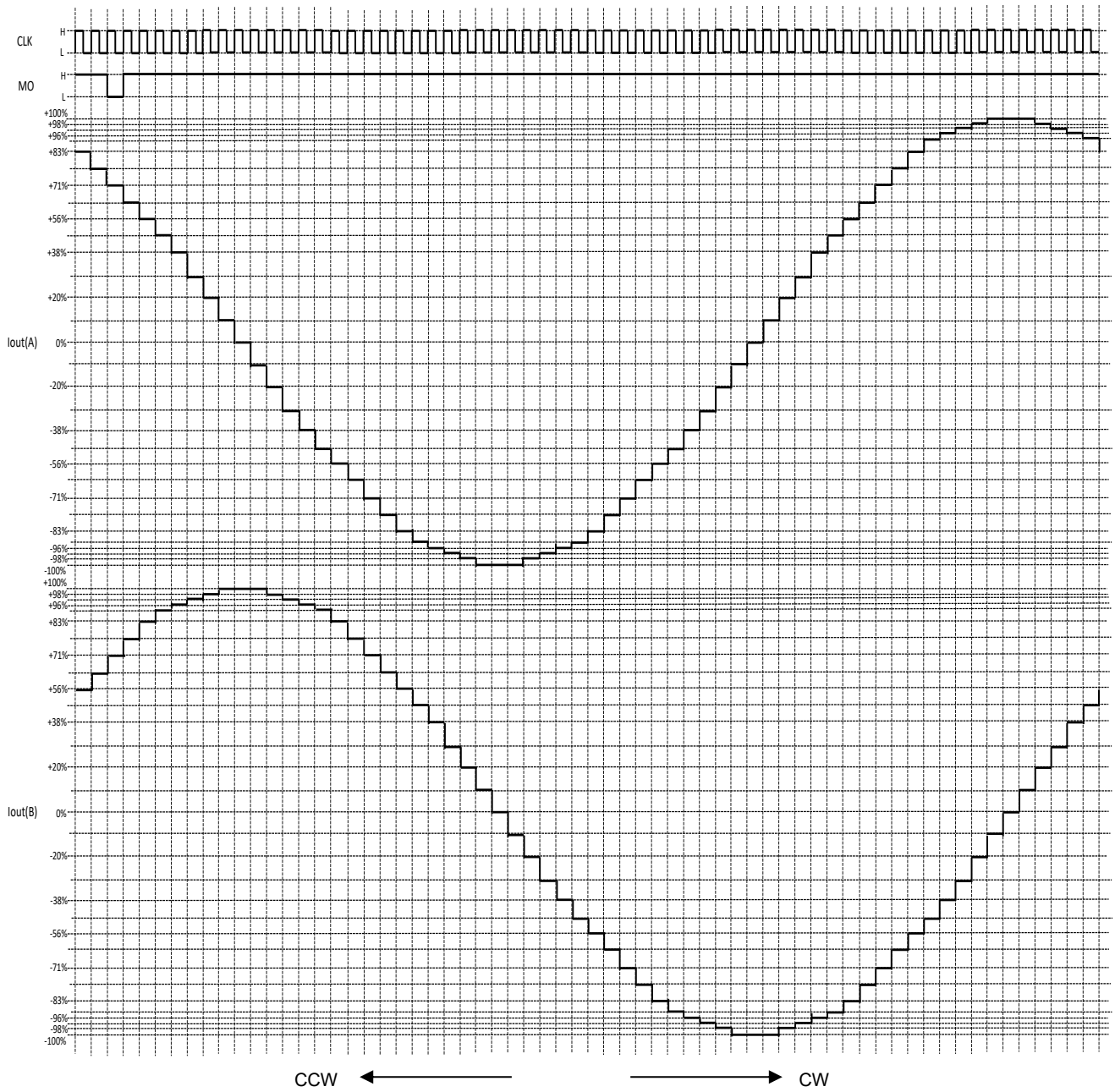

Figure 6.6 1/16 step resolution setting

Waveform of MO output: State of pull-up.

Note: Timing charts may be simplified for explanatory purpose.

6.6.7. 1/32 step resolution setting

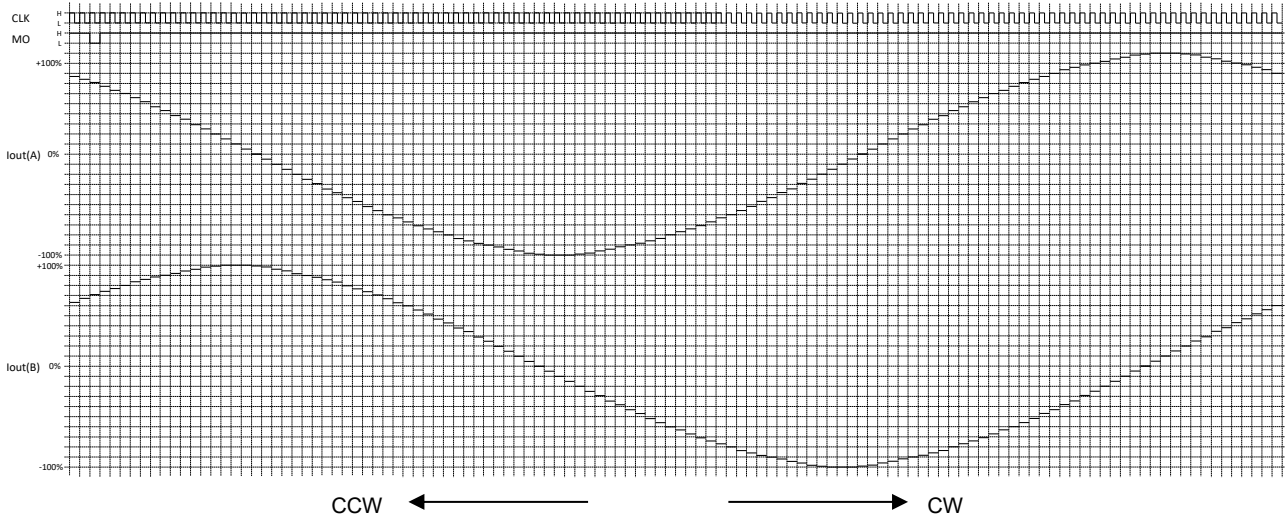

Figure 6.7 1/32 step resolution setting

Waveform of MO output: State of pull-up.

Note: Timing charts may be simplified for explanatory purpose.

6.7. Step resolution and set current

For step current of each resolution, refer to the following tables. The values in the case of CW_CCW=High setting are shown.

Table 6.6 step current of each resolution

STEP	1/32		1/16		1/8		1/4		1/2(b)		1/2(a)		Full	
	Ach (%)	Bch (%)	Ach (%)	Bch (%)	Ach (%)	Bch (%)	Ach (%)	Bch (%)	Ach (%)	Bch (%)	Ach (%)	Bch (%)	Ach (%)	Bch (%)
00	100	0	100	0	100	0	100	0	100	0	100	0		
01	100	5												
02	100	10	100	10										
03	99	15												
04	98	20	98	20	98	20								
05	97	24												
06	96	29	96	29										
07	94	34												
08	92	38	92	38	92	38	92	38						
09	90	43												
010	88	47	88	47										
011	86	51												
012	83	56	83	56	83	56								
013	80	60												
014	77	63	77	63										
015	74	67												
016	71	71	71	71	71	71	71	71	71	71	100	100	100	100
017	67	74												
018	63	77	63	77										
019	60	80												
020	56	83	56	83	56	83								
021	51	86												
022	47	88	47	88										
023	43	90												
024	38	92	38	92	38	92	38	92						
025	34	94												
026	29	96	29	96										
027	24	97												
028	20	98	20	98	20	98								
029	15	99												
030	10	100	10	100										
031	5	100												
032	0	100	0	100	0	100	0	100	0	100	0	100		
033	-5	100												
034	-10	100	-10	100										
035	-15	99												
036	-20	98	-20	98	-20	98								
037	-24	97												
038	-29	96	-29	96										

STEP	1/32		1/16		1/8		1/4		1/2(b)		1/2(a)		Full	
	Ach (%)	Bch (%)	Ach (%)	Bch (%)	Ach (%)	Bch (%)	Ach (%)	Bch (%)	Ach (%)	Bch (%)	Ach (%)	Bch (%)	Ach (%)	Bch (%)
039	-34	94												
040	-38	92	-38	92	-38	92	-38	92						
041	-43	90												
042	-47	88	-47	88										
043	-51	86												
044	-56	83	-56	83	-56	83								
045	-60	80												
046	-63	77	-63	77										
047	-67	74												
048	-71	71	-71	71	-71	71	-71	71	-71	71	-100	100	-100	100
049	-74	67												
050	-77	63	-77	63										
051	-80	60												
052	-83	56	-83	56	-83	56								
053	-86	51												
054	-88	47	-88	47										
055	-90	43												
056	-92	38	-92	38	-92	38	-92	38						
057	-94	34												
058	-96	29	-96	29										
059	-97	24												
060	-98	20	-98	20	-98	20								
061	-99	15												
062	-100	10	-100	10										
063	-100	5												
064	-100	0	-100	0	-100	0	-100	0	-100	0	-100	0		
065	-100	-5												
066	-100	-10	-100	-10										
067	-99	-15												
068	-98	-20	-98	-20	-98	-20								
069	-97	-24												
070	-96	-29	-96	-29										
071	-94	-34												
072	-92	-38	-92	-38	-92	-38	-92	-38						
073	-90	-43												
074	-88	-47	-88	-47										
075	-86	-51												
076	-83	-56	-83	-56	-83	-56								
077	-80	-60												
078	-77	-63	-77	-63										
079	-74	-67												
080	-71	-71	-71	-71	-71	-71	-71	-71	-71	-71	-100	-100	-100	-100
081	-67	-74												

STEP	1/32		1/16		1/8		1/4		1/2(b)		1/2(a)		Full	
	Ach (%)	Bch (%)	Ach (%)	Bch (%)	Ach (%)	Bch (%)	Ach (%)	Bch (%)	Ach (%)	Bch (%)	Ach (%)	Bch (%)	Ach (%)	Bch (%)
082	-63	-77	-63	-77										
083	-60	-80												
084	-56	-83	-56	-83	-56	-83								
085	-51	-86												
086	-47	-88	-47	-88										
087	-43	-90												
088	-38	-92	-38	-92	-38	-92	-38	-92						
089	-34	-94												
090	-29	-96	-29	-96										
091	-24	-97												
092	-20	-98	-20	-98	-20	-98								
093	-15	-99												
094	-10	-100	-10	-100										
095	-5	-100												
096	0	-100	0	-100	0	-100	0	-100	0	-100	0	-100		
097	5	-100												
098	10	-100	10	-100										
099	15	-99												
0100	20	-98	20	-98	20	-98								
0101	24	-97												
0102	29	-96	29	-96										
0103	34	-94												
0104	38	-92	38	-92	38	-92	38	-92						
0105	43	-90												
0106	47	-88	47	-88										
0107	51	-86												
0108	56	-83	56	-83	56	-83								
0109	60	-80												
0110	63	-77	63	-77										
0111	67	-74												
0112	71	-71	71	-71	71	-71	71	-71	71	-71	100	-100	100	-100
0113	74	-67												
0114	77	-63	77	-63										
0115	80	-60												
0116	83	-56	83	-56	83	-56								
0117	86	-51												
0118	88	-47	88	-47										
0119	90	-43												
0120	92	-38	92	-38	92	-38	92	-38						
0121	94	-34												
0122	96	-29	96	-29										
0123	97	-24												
0124	98	-20	98	-20	98	-20								

STEP	1/32		1/16		1/8		1/4		1/2(b)		1/2(a)		Full	
	Ach (%)	Bch (%)	Ach (%)	Bch (%)	Ach (%)	Bch (%)	Ach (%)	Bch (%)	Ach (%)	Bch (%)	Ach (%)	Bch (%)	Ach (%)	Bch (%)
—														
θ125	99	-15												
θ126	100	-10	100	-10										
θ127	100	-5												
θ128	100	0	100	0	100	0	100	0	100	0	100	0		

6.8. Selectable Mixed Decay Function

Selectable Mixed Decay function can adjust the regeneration amount of the current during Decay period using the DECAY pins.

Mixed Decay control is realized by changing three controls: Charge, Slow Decay, and Fast Decay.

The constant-current control can be selected from the following four settings by DECAY pins. When this setting is changed during the constant-current operation, the changed setting is applied from next chopping cycle.

Table 6.7 Selectable Mixed Decay Function

DECAY2 pin	DECAY1 pin	Function
L	L	Mixed Decay
L	H	Slow Decay only
H	L	Fast Decay only
H	H	ADMD

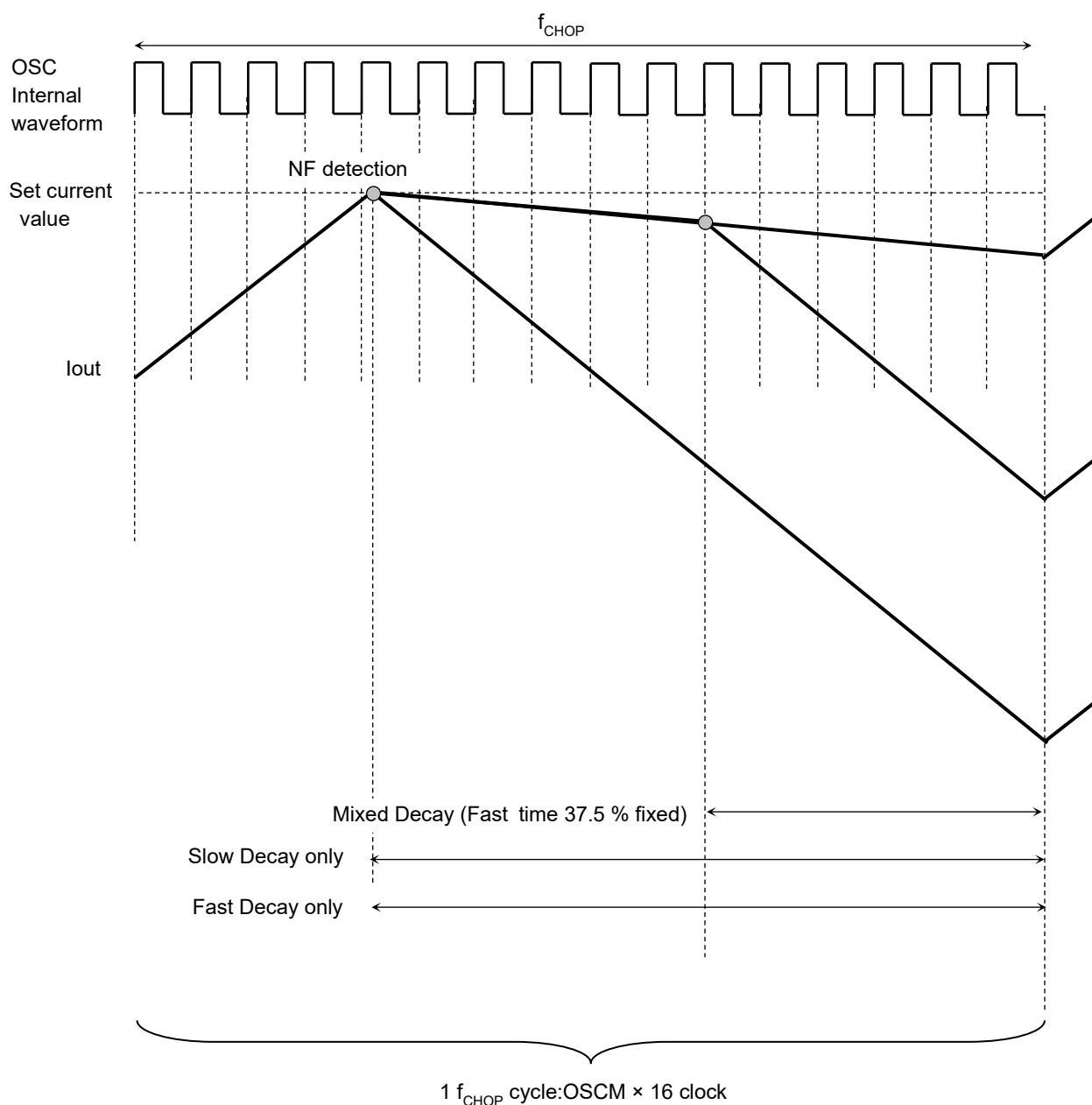

Figure 6.8 Selectable Mixed Decay Function

Note: Timing charts may be simplified for explanatory purpose

6.8.1. Mixed Decay Waveform (Current Waveform)

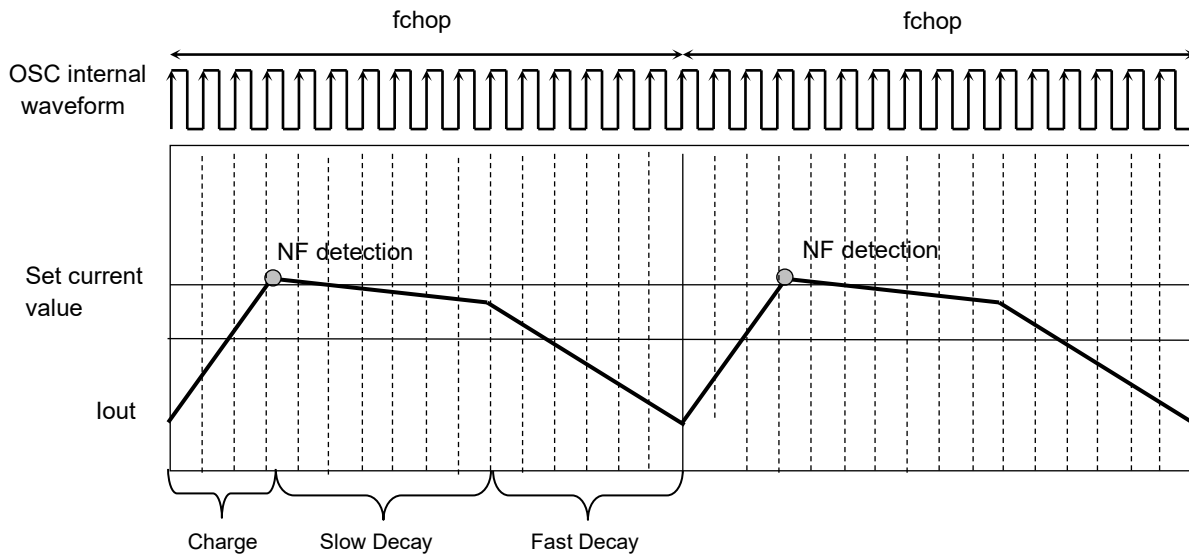

Figure 6.9 Mixed Decay Waveform

Note: Timing charts may be simplified for explanatory purpose.

6.8.2. Each Time of Constant Current PWM Operation

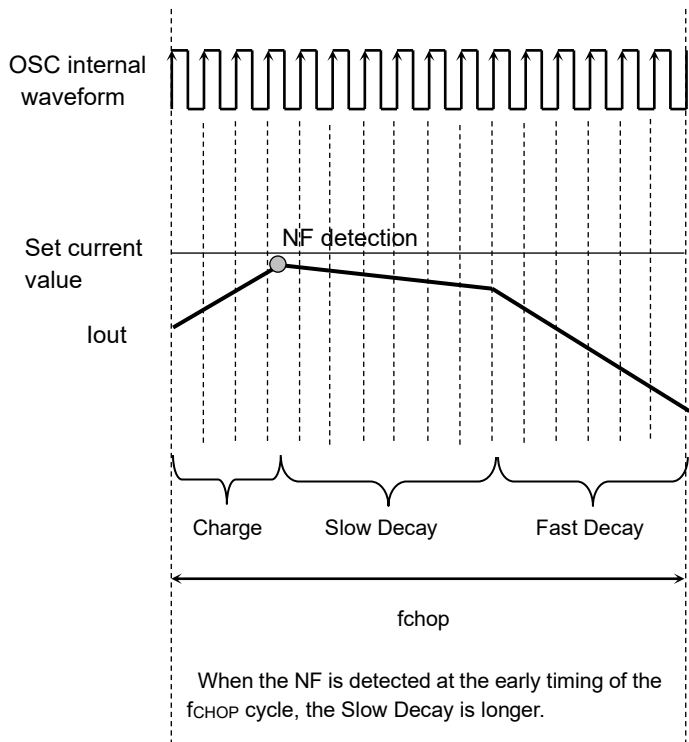

Figure 6.10
Each Time of Constant Current (1)

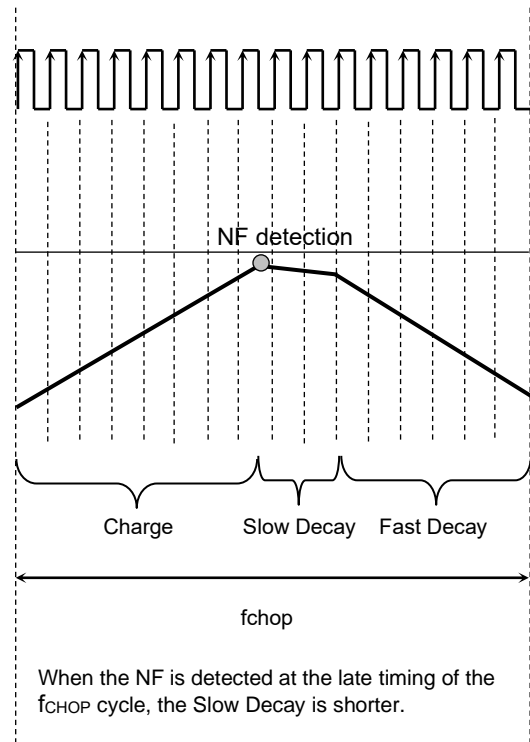

Figure 6.11
Each Time of Constant Current (2)

The Charge period (the time until the motor current reaches the set current value) is determined by the operating status.

Therefore, the NF detection (the motor current reaches the set current value) timing with in the chopping cycle will change. When the NF is detected at the early timing of the f_{CHOP} cycle, the Slow Decay is longer. When the NF is detected at the late timing of the f_{CHOP} cycle, the Slow Decay is shorter, as shown above.

Note: The chopping cycle is determined as: $f_{CHOP} - (\text{Charge} + \text{Fast Decay}) = \text{Slow Decay}$
(Fast Decay time is 37.5 % fixed (OSCM: 6 clocks))

Note: Timing charts may be simplified for explanatory purpose.

6.8.3. Mixed Decay Current Waveform

6.8.3.1. When the set current value is increased

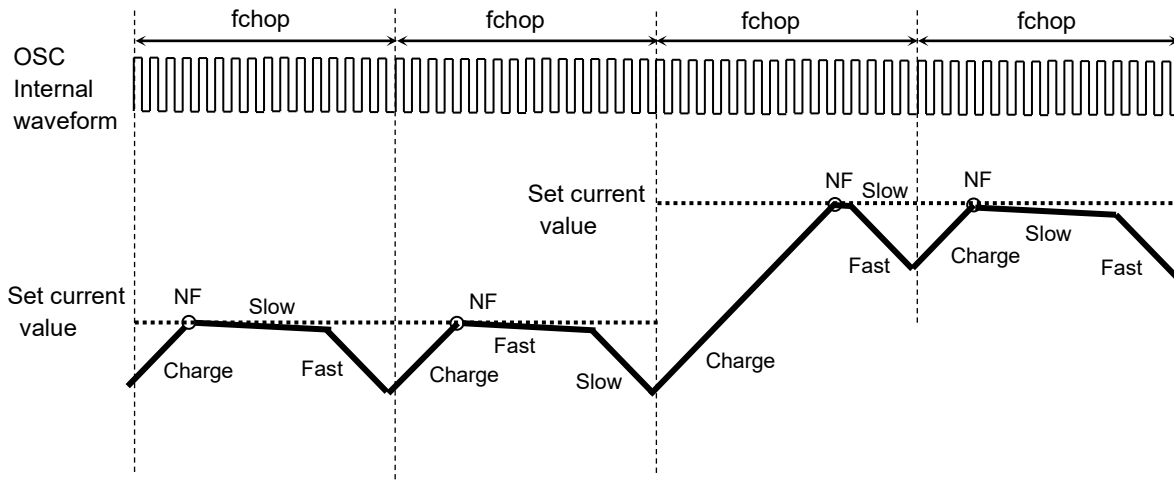

Figure 6.12 When the set current value is increased

6.8.3.2. When the Charge period is more than 1 f_{CHOP} cycle

When the Charge period (the motor current reaches next step of the set current value) is longer than 1 f_{CHOP} cycle, the Charge period extends until the motor current reaches the NF threshold. Once the current reaches the next current step, then the sequence goes on to Mixed Decay control.

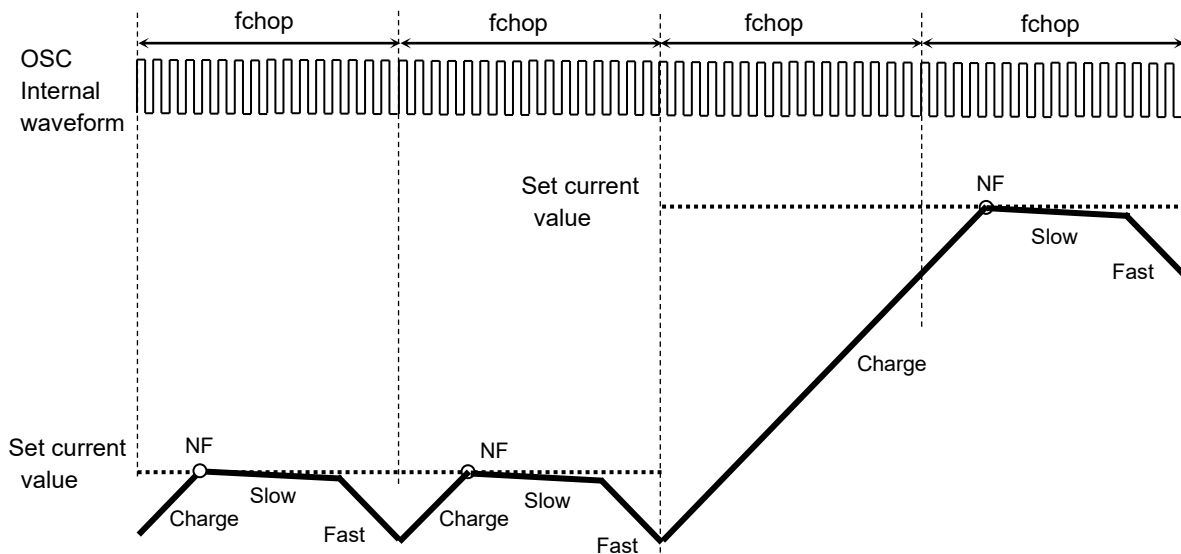

Figure 6.13 When the Charge period is more than 1 f_{CHOP} cycle

6.8.3.3. When the set current value is decreased

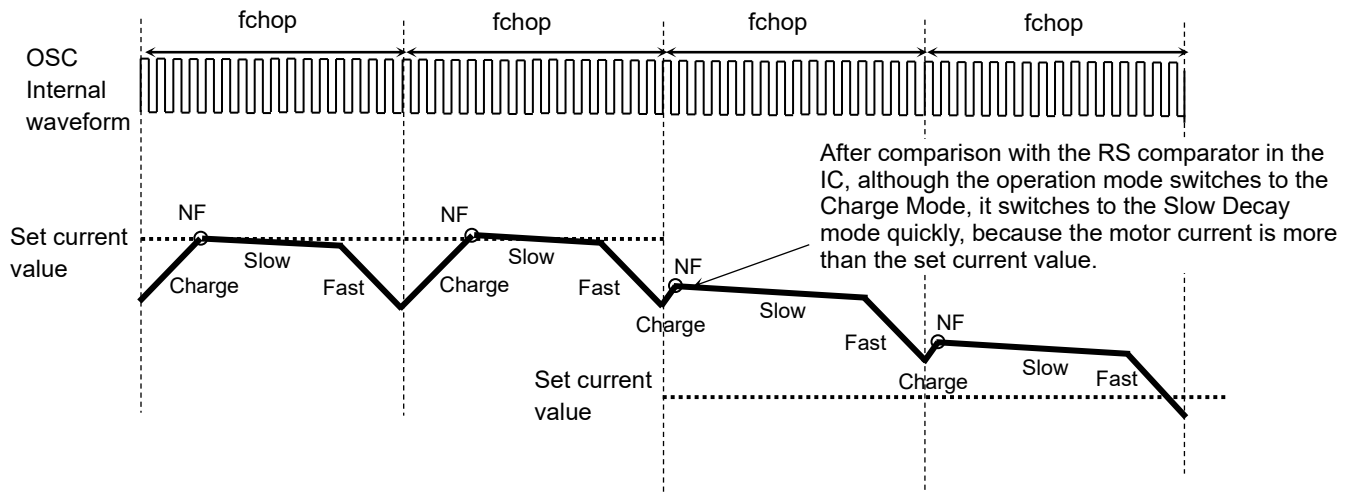

Figure 6.14 When the set current value is decreased

Note: Timing charts may be simplified for explanatory purpose.

6.9. ADMD (Advanced Dynamic Mixed Decay) Constant Current Control

The ADMD monitors both the current which flows from the power supply to the motor, and the current which regenerates from the motor to the power supply. The ADMD also controls constant current PWM. The basic sequence of the ADMD is as follows.

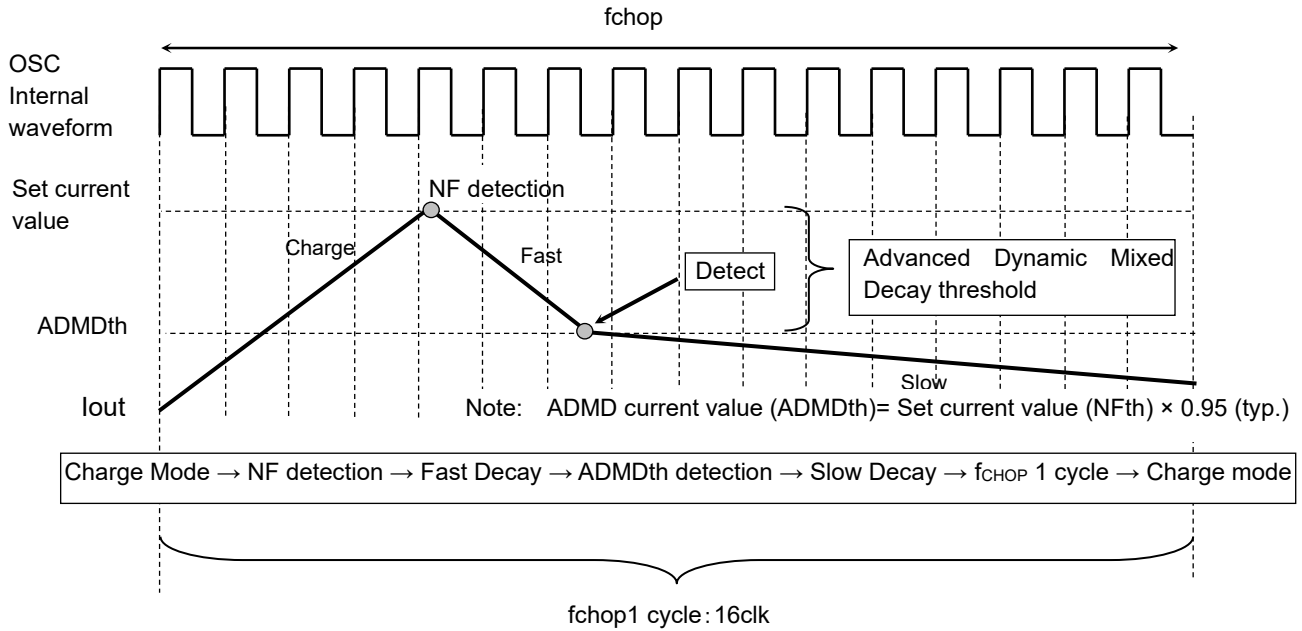

Figure 6.15 ADMD (Advanced Dynamic Mixed Decay) Constant Current Control

Note: Timing charts may be simplified for explanatory purpose. The values in the timing chart are reference values.

Each filter is attached in order to avoid current-detection error caused by the external noise, etc. (Shown in below figure.)

L value of the motor to be used is small, and when the current value reaches ADMDth (ADMD current value) within the ADMDtblank period, it changes to Slow operation after the ADMDtblank period elapsed. In this case, the ADMD current value (ADMDth) becomes smaller than "the set current value (NFth) x 0.95 (typ.)".

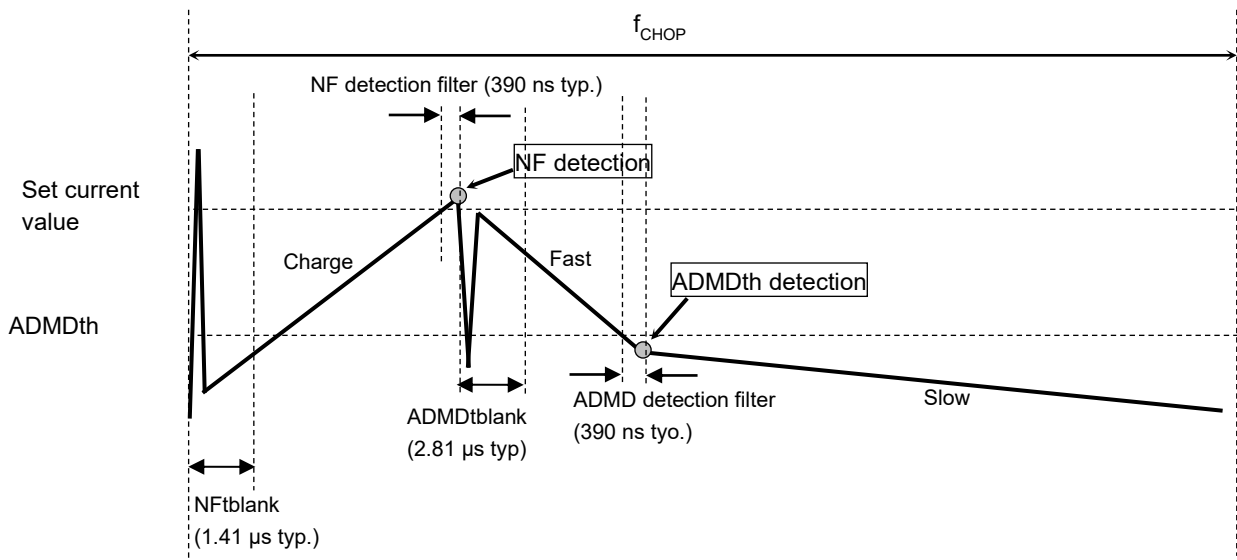

Figure 6.16 Each filter settings

Note : Timing charts may be simplified for explanatory purpose. The values in the timing chart are reference values.

6.9.1. Auto Decay Mode Current Waveform

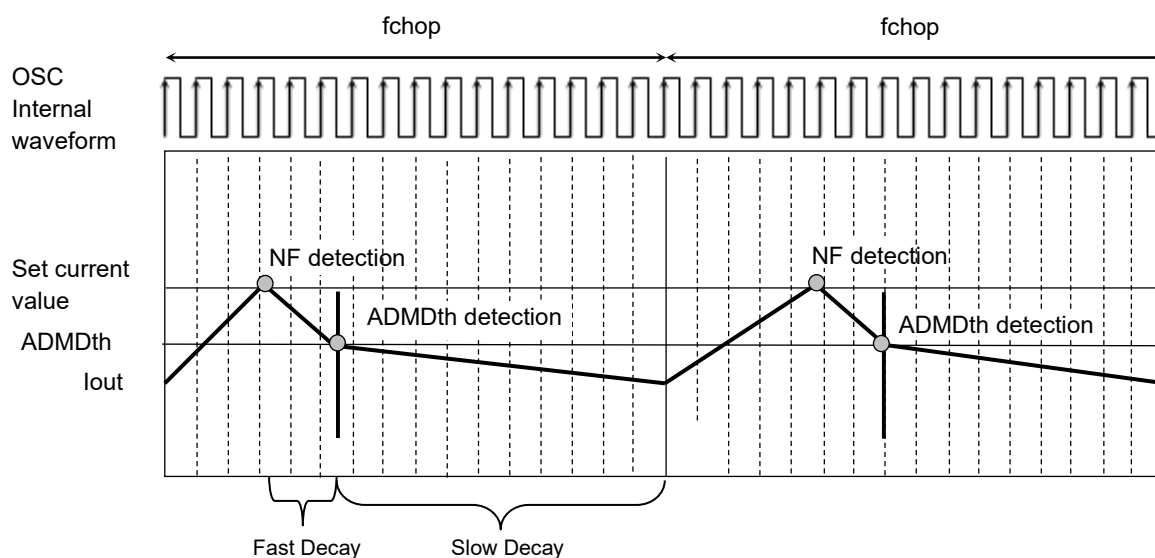

Figure 6.17 Auto Decay Mode Current Waveform

Note: Timing charts may be simplified for explanatory purpose.

6.9.1.1. When the next current value is increased

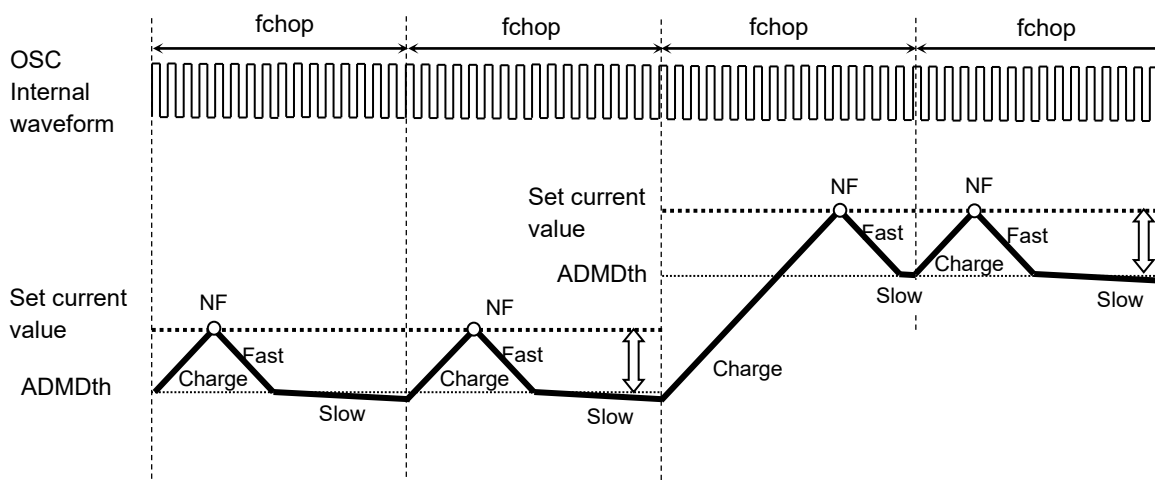

Figure 6.18 When the next current value is increased

6.9.1.2. When Charge period $\geq 1 f_{CHOP}$ cycle

When the period until the motor current value reaches the next setting value (Charge period) such as switching

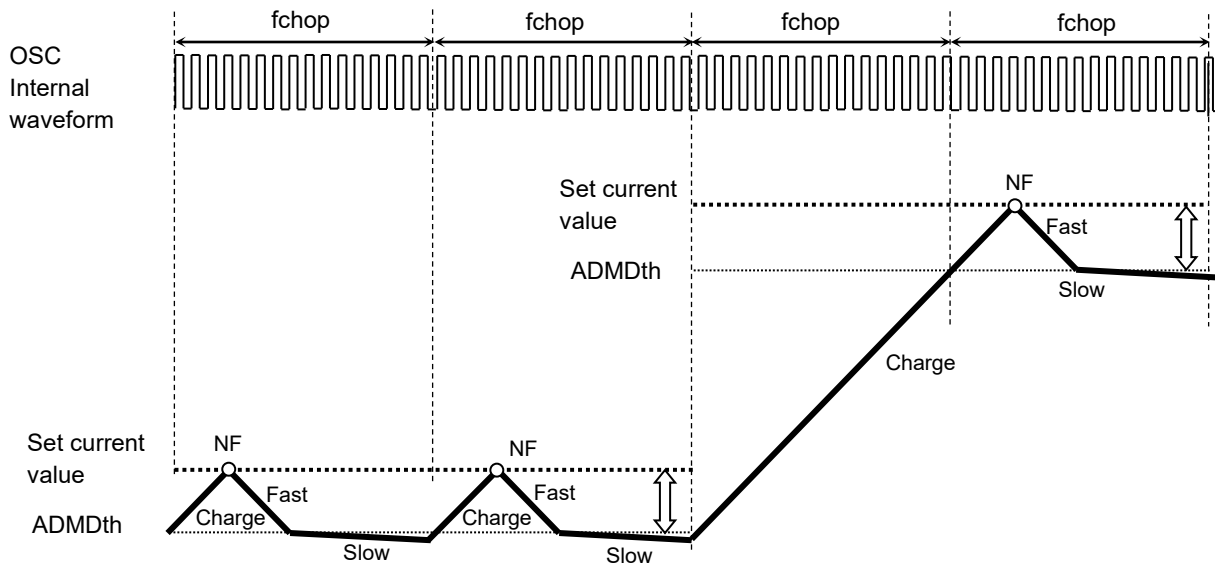

Figure 6.19 When Charge period $\geq 1 f_{CHOP}$ cycle

Note: Timing charts may be simplified for explanatory purpose.

6.9.1.3. When the next current value is decreased

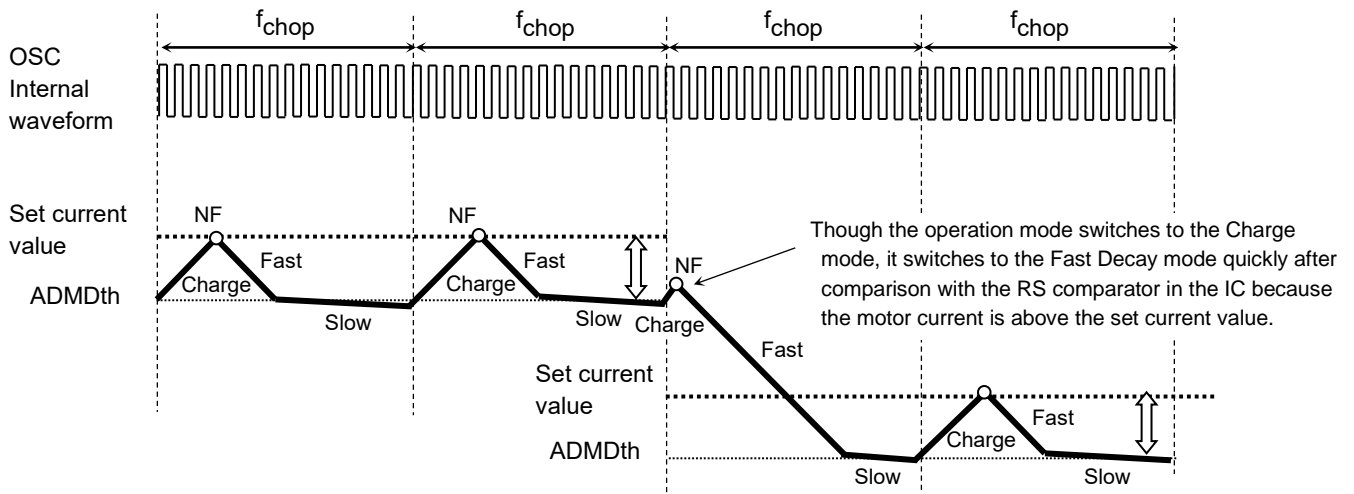

Figure 6.20 When the next current value is decreased

6.9.1.4. Fast period > 1 f_{CHOP} cycle

(The motor current does not reach the ADMD threshold during 1 f_{CHOP} cycle.)

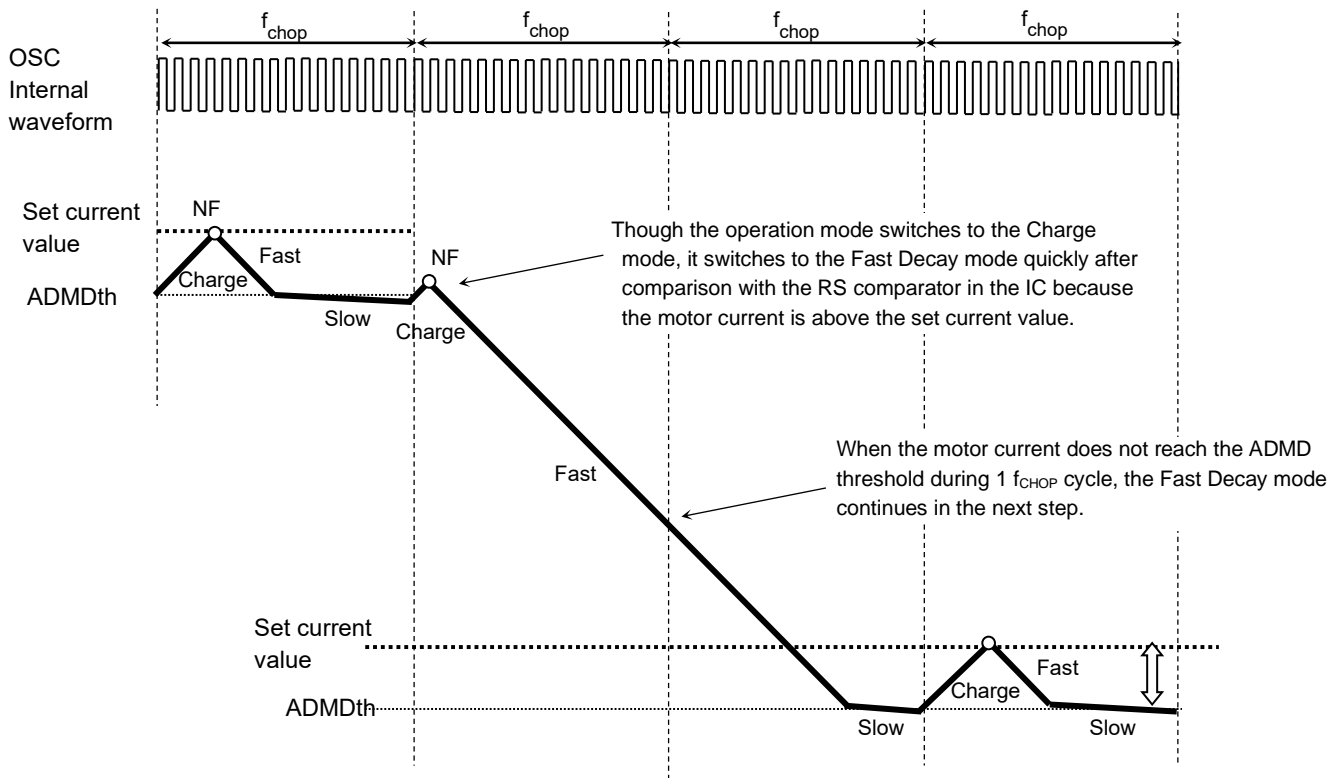

Figure 6.21 Fast period > 1 f_{CHOP} cycle

Note: Timing charts may be simplified for explanatory purpose.

6.10. RESET function

The RESET pin initializes the internal electrical angles.

Table 6.8 RESET function

RESET	Function
H	Set the electrical angle to the initial state
L	Normal operation

The current of each channel (while the RESET pin is applied) is as follows.

Step resolution	A ch current	B ch current	Initial electrical angle
Full step resolution	100 %	100 %	45 °
Half step resolution (a)	100 %	100 %	45 °
Half step resolution (b)	71 %	71 %	45 °
Quarter step resolution	71 %	71 %	45 °
1/8 step resolution	71 %	71 %	45 °
1/16 step resolution	71 %	71 %	45 °
1/32 step resolution	71 %	71 %	45 °

6.11. Torque function

TRQ pins set the torque of the motor.

Table 6.9 Torque function

TRQ1 pin input	TRQ0 pin input	Function
L	L	Torque setting: 100 %
L	H	Torque setting: 75 %
H	L	Torque setting: 50 %
H	H	Torque setting: 25 %

6.12. MO function

The MO pin confirms the internal electrical angles. The output of the MO pin should be connected to 3.3V or 5 V power supply with a pull-up resistor in the range of 10 k to 100 kΩ.

Table 6.10 MO function

MO	Function
H (Pull-up)	Electrical angle: Except initial value
L	Electrical angle: Initial value

6.13. LO (Error detection flag output) function

The LO function outputs signals when the error detection operates.

Both pins are open drain type. Therefore, to use function properly, the LO1 and LO2 pins should be connected to 3.3 V or 5 V power supply with a pull-up resistor in the range of 10 k to 100 kΩ.

During normal operation, the LO1 pin is high-impedance (the internal MOSFET is OFF). When the error detections (thermal shutdown (TSD) and over-current detection (ISD)) operate, the pins output Low (the internal MOSFET is ON).

When reasserting the VM power or using the SLEEP mode to release the error detection status, the LO pins return to “normal operation mode” again. When the LO pins are not used, the pins should be open. The LO2 pin outputs Low only when the TSD is detected.

Table 6.11 LO function

LO1 pin output	Function
H (Pull-up)	Normal status (Normal operation)
L	Detected over-current (ISD) and over-temperature (TSD) status

LO2 pin output	Function
H (Pull-up)	Normal status (Normal operation)
L	Detected over-temperature (TSD) status

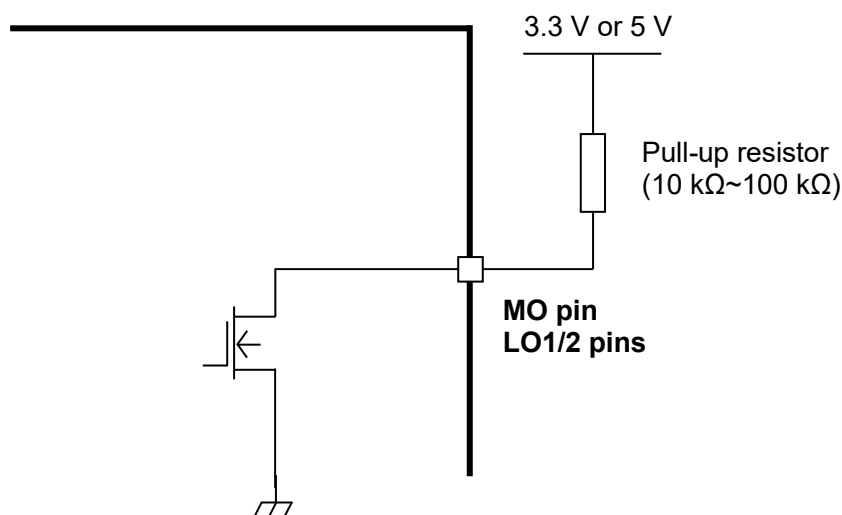

Figure 6.22 LO function Equivalent Circuit

Note: The equivalent circuit diagrams may be simplified or omitted for explanatory purposes.

6.14. Output Transistor Function mode (Advanced Dynamic Mixed Decay)

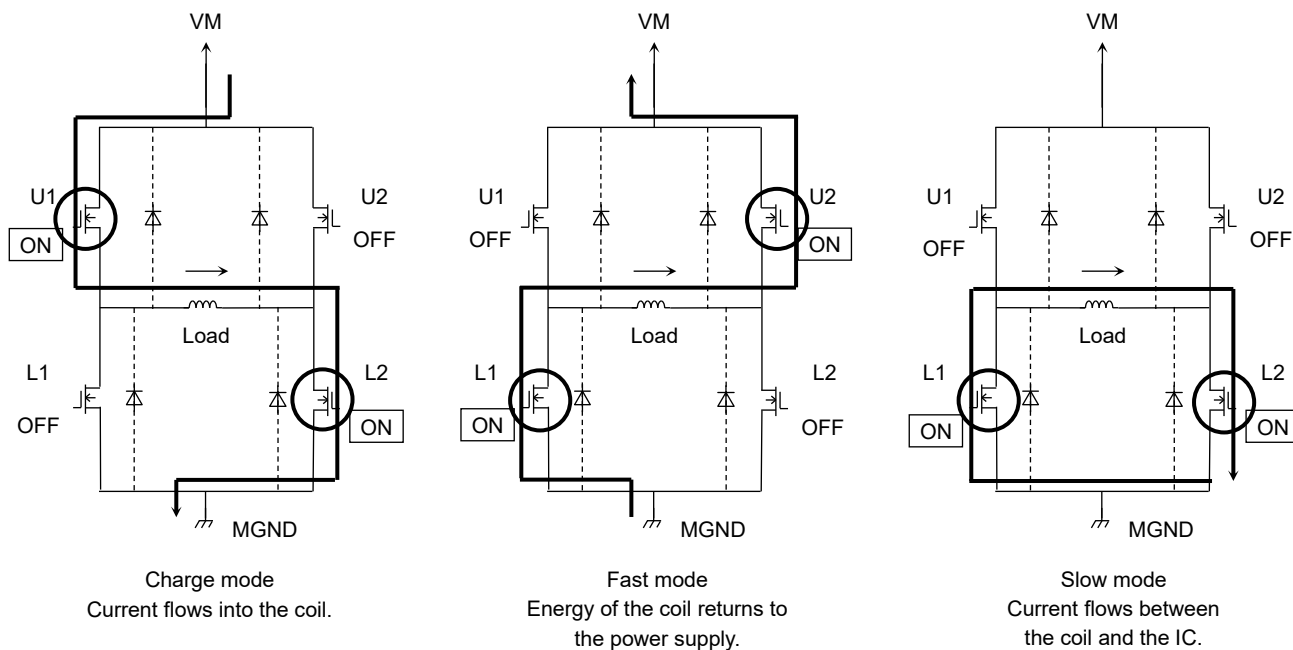

Figure 6.23 Output Transistor Function mode

Note: When the output switches, cross-conduction protection time is provided in the IC to avoid penetrating current.

Table 6.12 Output transistor function

Mode	U1	U2	L1	L2
CHARGE	ON	OFF	OFF	ON
FAST	OFF	ON	ON	OFF
SLOW	OFF	OFF	ON	ON

Note: This table shows an example of when the current flows as indicated by the arrows in the above figures. When the current flows in the opposite direction, refer to the following table.

Mode	U1	U2	L1	L2
CHARGE	OFF	ON	ON	OFF
FAST	ON	OFF	OFF	ON
SLOW	OFF	OFF	ON	ON

This IC controls the motor current to be constant by 3 modes listed above. The equivalent circuit diagrams may be simplified or some parts of them may be omitted for explanatory purposes.

6.15. Set current value (I_{OUT})

The setting current value in the PWM constant-current control mode is determined by the reference voltage (V_{REF}) as follows;

The current value to be set can be calculated by the following formula.

$$I_{OUT} = V_{REF} \times 0.556$$

e.g.: When V_{REF} = 2.0 V, I_{OUT} = 1.11 A

6.16. Chopping frequency (f_{CHOP})

Chopping frequency of the constant-current control can be configured by the resistor (R_{OSC}) connected to OSCM pin. The IC can operate by the fixed chopping frequency without attaching the external part to OSCM pin.

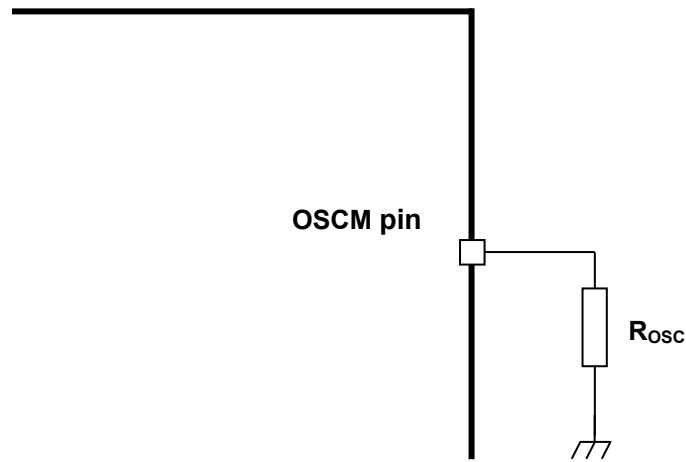

Figure 6.24 OSCM pin Equivalent Circuit

Note: The equivalent circuit diagrams may be simplified or some parts of them may be omitted for explanatory purposes.

Chopping frequency (f_{CHOP}) is calculated from below formula.

Generally, a standard frequency is approximately 70 kHz. A setup in the range of 40 to 100 kHz is recommended.

$$f_{CHOP} = f_{OSCM} / 16$$

$$f_{OSCM} = 1 / (\alpha \times R_{osc} + \beta) \text{ [MHz]} \quad \alpha = 1.7 \times 10^{-5}, \beta = 0.0285$$

e.g.: When R_{OSC}=47 kΩ, f_{OSCM}=1.2 MHz (typ.), f_{CHOP}=75 kHz (typ.)

Under the condition that OSCM pin is open or connected to the GND, the IC operates by the frequency generated automatically (f_{OSCM2}=914 kHz (typ.), f_{CHOP}=57.1 kHz (typ.)).

6.17. Power consumption of the IC

Power of the IC is consumed by the transistor of the output block and that of the logic block mainly.

6.17.1. Power consumption of the power transistor

Power of the output block is consumed by the upper and lower MOSFET of the H-Bridge.

Power consumption of the upper or lower transistor of the H-Bridge is calculated from below formula.

$$P(\text{out}) = I_{\text{out}}(\text{A}) \times V_{\text{DS}}(\text{V}) = I_{\text{out}}(\text{A})^2 \times R_{\text{on}}(\Omega) \dots\dots\dots(1)$$

When the current waveform of the motor output corresponds to the complete square waveform in the full-step resolution, average power of output block can be provided as follows

$$\begin{aligned} &\text{When } R_{\text{on}} = 0.8 \Omega, I_{\text{out}}(\text{peak : Max}) = 1.0 \text{ A, } V_{\text{M}} = 24 \text{ V,} \\ &P(\text{out}) = 2(\text{Tr}) \times 1.0(\text{A})^2 \times 0.8(\Omega) \dots\dots\dots(2) \\ &= 1.6(\text{W}) \end{aligned}$$

6.17.2. Power consumption of logic and IM systems

Power consumptions of logic and IM systems are calculated by separating the states (operating and stopping).

- I (IM3) = 5.4 mA (typ.) : Operatin/axis
- I (IM2) = 4.8 mA (typ.) : Stopping/axis
- I (IM1) = 0.03 μA (typ.) : Standby/axis

Output system is connected to VM (24V).(Output system: Current consumed by the circuit connected to VM + Current consumed by switching output stages)

Power consumption is calculated as follows;

$$\begin{aligned} P(\text{IM3}) &= 24(\text{V}) \times 0.0054(\text{A}) \dots\dots\dots(3) \\ &= 0.13(\text{W}) \end{aligned}$$

6.17.3. Power consumption

Total power consumption P is calculated from the results of “1” and “2” above.

$$P = P(\text{out}) + P(\text{IM3}) = 1.73(\text{W})$$

Power consumption of 1 axis in standby mode is as follows;

$$P(\text{Sleep mode}) = 24(\text{V}) \times 0.03(\mu\text{A}) = 0.72(\mu\text{W})$$

About the heat design of the board etc., please evaluate it by the actual board enough, and configure the appropriate margin.

6.18. Detection Function

Built-in below detection functions.

Table 6.13 Detection function

Detection	Target	Detection level	Protection method	Resume method from detection state
Thermal shutdown (TSD)	Chip temperature	160 °C (typ.) or more Dead band time of 5.0 μs (typ.)	All outputs are OFF forcedly.	This function is a latch type that maintains the operation at the time of detection. The operation resumes by below process. • Power supply is reapplied. • SLEEP mode is set once and normal mode is set again.
Over-current detection (ISD)	Output current	3 A (typ.) or more Dead band time of 1.25 μs (typ.)	All outputs are OFF forcedly.	
Under voltage lockout (UVLO)	Voltage of VM pin	4.0 V (typ.) or less Dead band time of 1.41 μs (typ.)	All outputs are OFF forcedly. Internal circuits are reset.	

6.18.1. Thermal shutdown detection

(This function is a latch type that maintains the operation at the time of detection.)

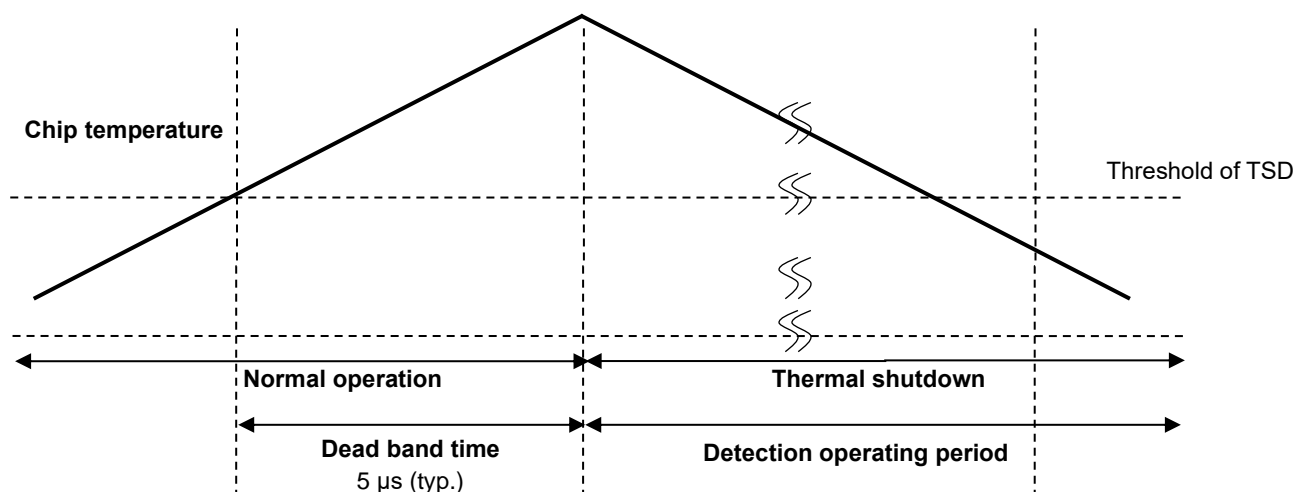
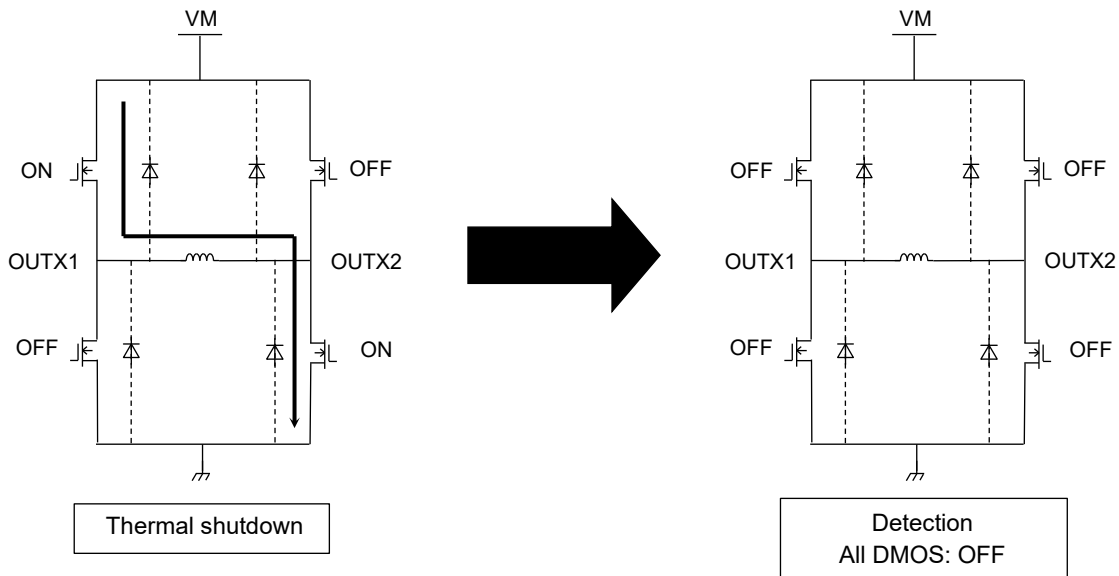

Figure 6.25 Thermal shutdown detection

Note: Timing charts may be simplified for explanatory purposes. The value in the timing chart is the reference value.

6.18.1.1. When over temperature is detected:



X=A or B

Figure 6.26 When over temperature is detected

6.18.2. Over-current detection

(This function is a latch type that maintains the operation at the time of detection.)

This function turns off the IC operation temporarily when the short-circuiting between outputs of motors and the short-circuiting to the power supply or ground occur. It has a dead band time to avoid error detection caused by the spike current which generates in switching and the external noise. When over-current is detected, not only the corresponding channels but both channels are turned off.

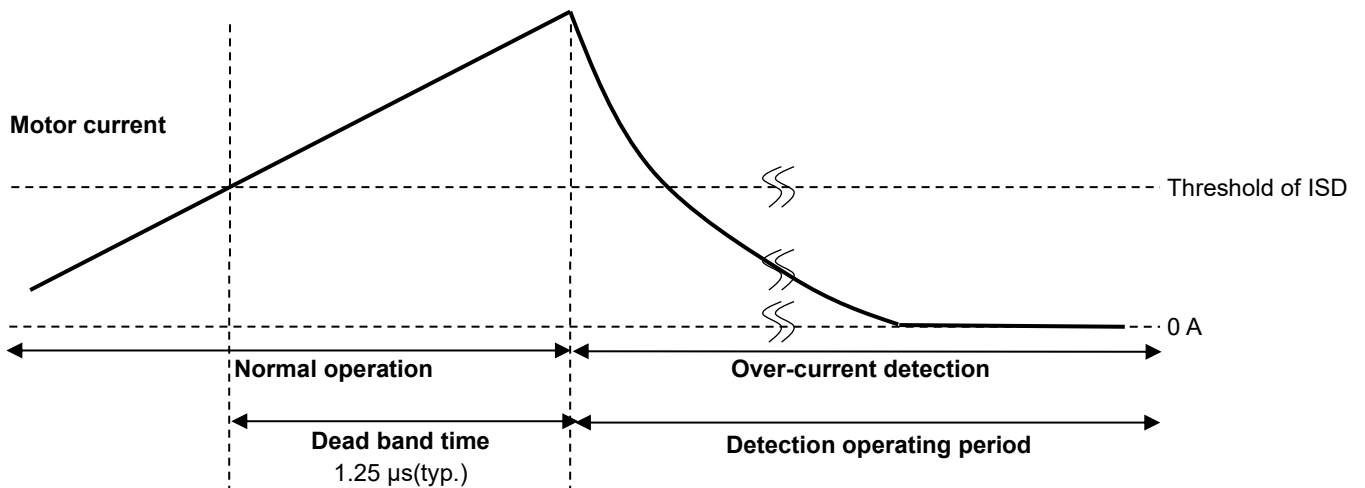
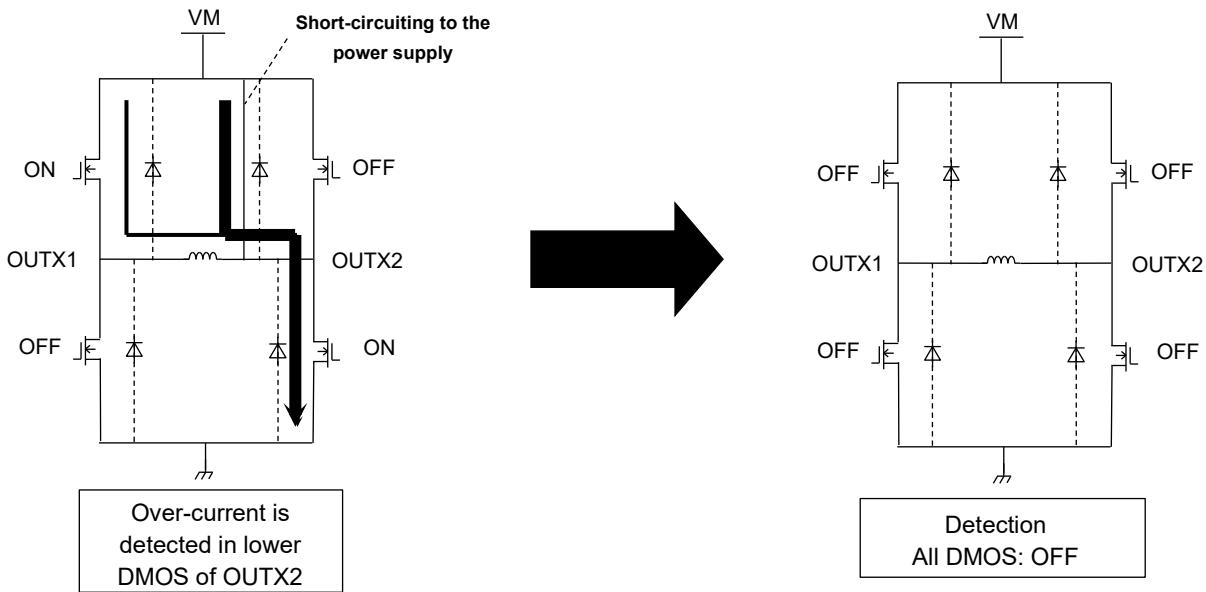

Figure 6.27 Over-current detection timing charts

Note: Timing charts may be simplified for explanatory purposes. The value in the timing chart is the reference value.

6.18.2.1. When over-current is detected in the lower DMOS of H-bridge by the short-circuiting to the power supply



X=A or B

Figure 6.28 When over-current is detected in the lower DMOS of H-bridge by the short-circuiting to the power supply

6.18.2.2. When over-current is detected in the upper DMOS of H-bridge by the short-circuiting to the ground:

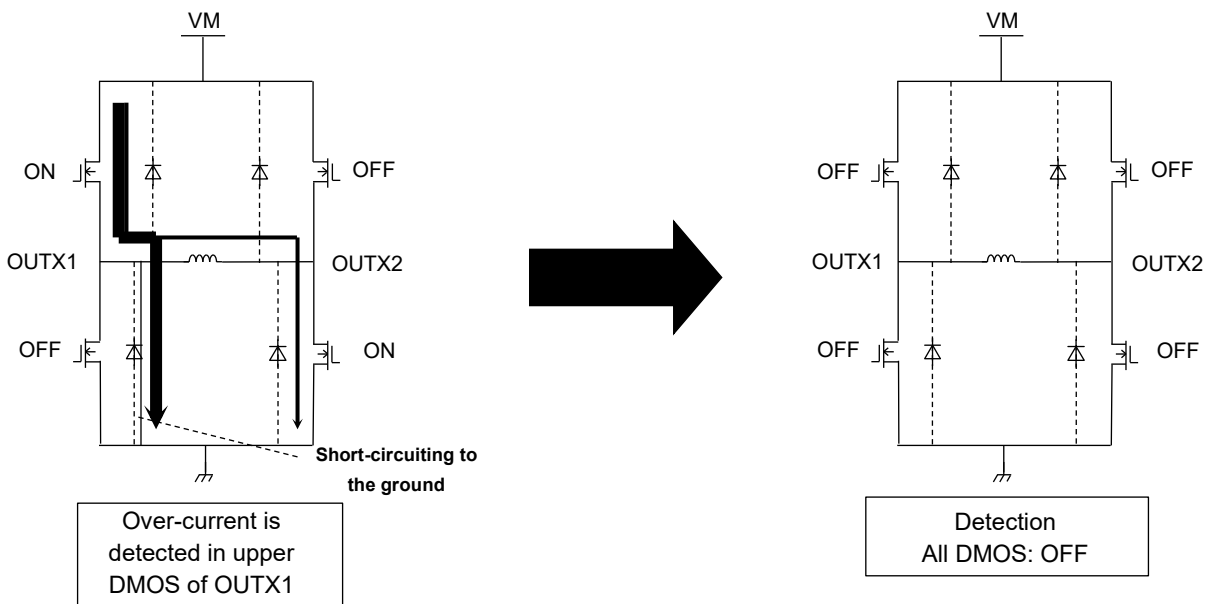

X=A or B

Figure 6.29 When over-current is detected in the upper DMOS of H-bridge by the short-circuiting to the ground

7. Absolute Maximum Ratings(Ta = 25 °C)

Table 7.1 Absolute Maximum Ratings

Characteristics	Symbol	Rating	Unit
Motor power supply	V _M	35	V
Motor output voltage	V _{OUT}	40	V
Motor output current (Note1)	I _{OUT}	2.0	A
Voltage for internal regulator	V _{CC}	6.0	V
Logic input pin voltage	V _{IN}	6.0	V
V _{ref} reference voltage	V _{ref}	6.0	V
MO and LO pins voltage	V _{MO}	6.0	V
Power dissipation (Note2)	P _D	1.3	W
Operating temperature	T _{opr}	-40 to 85	°C
Storage temperature	T _{stg}	-55 to 150	°C
Junction temperature	T _{J(MAX)}	150	°C

Note1: The maximum current value in normal operation should be kept 1.8 A or less per channel after calculating heat generation. The maximum output current may be further limited in view of the thermal considerations, depending on the ambient temperature and board conditions.

Note2: IC standalone (Ta = 25 °C)

When Ta exceeds 25 °C, derating with 10.4 mW/°C is necessary.

Ta : Ambient temperature of the IC

Topr : Ambient temperature while the IC is active.

Tj : Temperature of the chip while the IC is active. The maximum junction temperature is limited by the thermal shutdown circuit (TSD).

It is advisable to keep the maximum current below a certain level so that the maximum junction temperature, Tj (MAX), will not exceed 120 °C.

Absolute maximum ratings

The absolute maximum ratings of a semiconductor device are a set of ratings that must not be exceeded, even for a moment. Do not exceed any of these ratings.

Exceeding the rating(s) may cause device breakdown, damage or deterioration, and may result in injury by explosion or combustion. The value of even one parameter of the absolute maximum ratings should not be exceeded under any circumstances. The TB67S539FTG does not have overvoltage detection circuit. Therefore, the device is damaged if a voltage exceeding its rated maximum is applied.

All voltage ratings, including supply voltages, must always be followed. The other notes and considerations described later should also be referred to.

PD-Ta graph (reference)

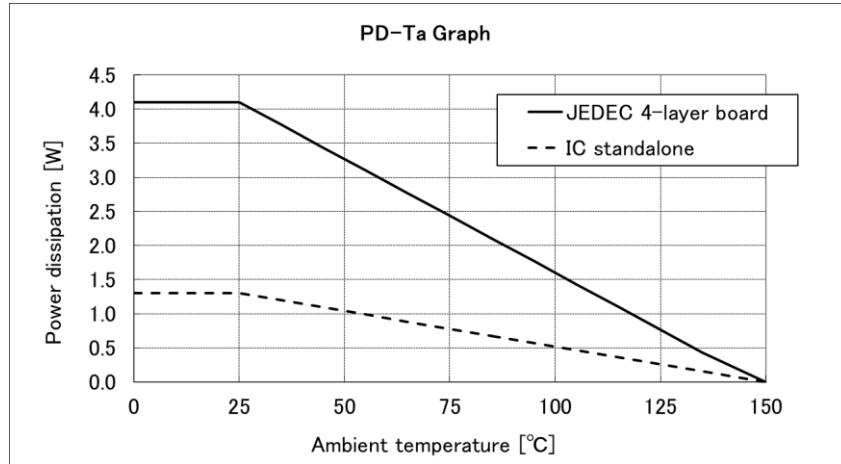

Figure7.1 PD-Ta graph

8. Operating Ranges(Ta = -20 to 85°C)

Table 8.1 Operating Ranges

Characteristics	Symbol	Min	Typ.	Max	Unit	Remarks
Motor power supply (Note1)	V _M	4.5	24.0	33	V	-
Motor output current	I _{OUT}	-	-	1.8	A	Per channel (Note 2)
Logic input voltage	V _{IN(H)}	2.0	-	5.5	V	Logic input High level
	V _{IN(L)}	-0.5	-	0.8	V	Logic input Low level
Chopping frequency	f _{CHOP}	40	70	150	kHz	-
Clock frequency	f _{CLK}	-	-	250	kHz	-
V _{ref} reference voltage	V _{REF}	0	-	3.6	V	-

Note1: For a slew rate of 0 V to 10 V when the power is turned on, use it under the condition of 1 ms or more.

If you use it under different conditions, please evaluate it thoroughly for your product alone or for the entire system, and decide whether or not it is applicable at your own risk.

Note2: The actual maximum current may be limited by the operating environment (operating conditions such as exciting mode and operating time, or by the surrounding temperature or board heat dissipation). Determine a realistic maximum current by calculating the heat generated under the operating environment.

9. Electrical Characteristics

9.1. Electrical Characteristics 1 (Ta = 25 °C, VM = 24 V, unless otherwise specified)

Table9.1 Electrical Characteristics 1

Characteristics		Symbol	Test condition	Min	Typ.	Max	Unit
Logic input pin Input voltage	High	V _{IN(H)}	Logic input pin (Note1)	2.0	-	5.5	V
	Low	V _{IN(L)}	Logic input pin (Note1)	-0.5	-	0.8	V
Input hysteresis		V _{IN(HYS)}	Logic input pin (Note1)	-	150	-	mV
Logic input pin Input current	High	I _{IN(H)}	Test logic input pin: 5 V	35	50	75	μA
	Low	I _{IN(L)}	Test logic input pin: 0 V	-	-	1	μA
LO and MO pins output voltage		V _{OL(MO)}	I _{OL} =5 mA, Output: Low	-	0.2	0.5	V
Power consumption		I _{M1}	Output: Open, Sleep mode	-	0.03	1	μA
		I _{M2}	Output: Open, SLEEP=H,ENABLE=L	-	4.8	5.5	mA
		I _{M3}	Output: Open (Full step resolution) SLEEP=H, ENABLE=H Chopping frequency: 40 kHz	-	5.4	7	mA
Motor output leakage current	Upper	I _{OH}	V _M = 35 V, V _{OUT} = 0 V	-	-	1	μA
	Lower	I _{OL}	V _M = V _{OUT} = 35 V	1	-	-	μA
Output current differential between channels		ΔI _{OUT1}	Output current differential between channels I _{OUT} = 1.0 A	-5	0	5	%
Output set current accuracy		ΔI _{OUT2}	I _{OUT} = 1.0 A	-5	0	5	%
Output transistor between drain and source On resistance (upper + lower)		R _{ON(D-S)}	T _j = 25 °C I _{OUT} = 2.0 A	-	0.8	0.88	Ω

Note1: V_{IN(H)} is defined as the V_{IN} voltage that changes the output voltage by being applied to the test pin and raising this voltage from 0 V gradually.

V_{IN(L)} is defined as the V_{IN} voltage that changes the output voltage by being applied to the test pin and lowering this voltage gradually.

The difference between V_{IN(H)} and V_{IN(L)} is defined as V_{IN(HYS)}.

9.2. Electrical Characteristics 2(Ta = 25 °C, VM = 24 V, unless otherwise specified)

Table9.2 Electrical Characteristics 2

Characteristics	Symbol	Test condition	Min	Typ.	Max	Unit
V _{ref} input current	I _{REF}	V _{ref} = 3.6 V	-	0	1	μA
V _{ref} decay ratio	V _{REF(GAIN)}	V _{ref} = 2.0 V	0.528	0.556	0.584	-
TSD threshold	T _{JTSD}	-	145	160	175	°C
VM power on reset voltage	V _{MPOR}	-	3.8	4.0	4.2	V
VM power on reset hysteresis	V _{MPOR(HYS)}	-	-	200	-	mV
Over-current detection threshold	I _{SD}	-	2.1	3.0	3.6	A

Back-EMF

While a motor is rotating, there is a timing at which power is fed back to the power supply. At that timing, the motor current recirculates back to the power supply due to the effect of the motor back-EMF.

If the power supply does not have enough sink capability, the power supply and output pins of the device might rise above the rated voltages. The magnitude of the motor back-EMF varies with usage conditions and motor characteristics. It must be fully verified that there is no risk that the TB67S539FTG or other components will be damaged or fail due to the motor back-EMF.

Over-Current Detection (ISD) and Thermal Shutdown (TSD)

- The ISD and TSD circuits are only intended to provide temporary protection against irregular conditions such as an output short-circuit; they do not necessarily guarantee the complete IC safety.
- If the device is used beyond the specified operating ranges, these circuits may not operate properly: then the device may be damaged due to an output short-circuit.
- The ISD circuit is only intended to provide a temporary protection against an output short-circuit. If such a condition persists for a long time, the device may be damaged due to overstress. Over-current conditions must be removed immediately by external hardware.

IC Mounting

Do not insert devices incorrectly or in the wrong orientation. Otherwise, it may cause breakdown, damage and/or deterioration of the device.

9.3. AC Electrical Characteristics(Ta = 25 °C, VM = 24 V)

Table9.3 AC Electrical Characteristics

Characteristics	Symbol	Test condition	Min	Typ.	Max	Unit
Minimum clock pulse width	t _{CLK(H)}	-	600	-	-	ns
	t _{CLK(L)}	-	600	-	-	ns
Minimum pulse width 1 of logic input signal	t _{RS(H)}	RESET, SLEEP_X , DECAY	1.5	-	-	μs
	t _{RS(L)}	RESET, SLEEP_X , DECAY	1.5	-	-	μs
Minimum pulse width 2 of logic input signal	t _{DTE(H)}	TRQ0/1, ENABLE	600	-	-	ns
	t _{DTE(L)}	TRQ0/1, ENABLE	600	-	-	ns
Set-up time	t _{SU(STEP)}	CW_CCW, DMODE0/1/2	600	-	-	ns
Hold time	t _{H(STEP)}	CW_CCW, DMODE0/1/2	600	-	-	ns
Output transistor Switching characteristics	t _r	-	40	70	100	ns
	t _f	-	50	80	110	ns
	t _{pLH(CLK)}	-	-	1000	-	ns
	t _{pHL(CLK)}	-	-	1000	-	ns
OSCM oscillation frequency	f _{OSCM1}	R _{osc} =47 kΩ	1020	1200	1380	kHz
	f _{OSCM2}	OSCM pin: Open or connecting to GND	777	914	1051	
Chopping frequency	f _{CHOP}	f _{OSCM} = 1200 kHz	-	75	-	kHz

AC Electrical Characteristics Timing Chart

TB67S539FTG (Relation between CLK and output)

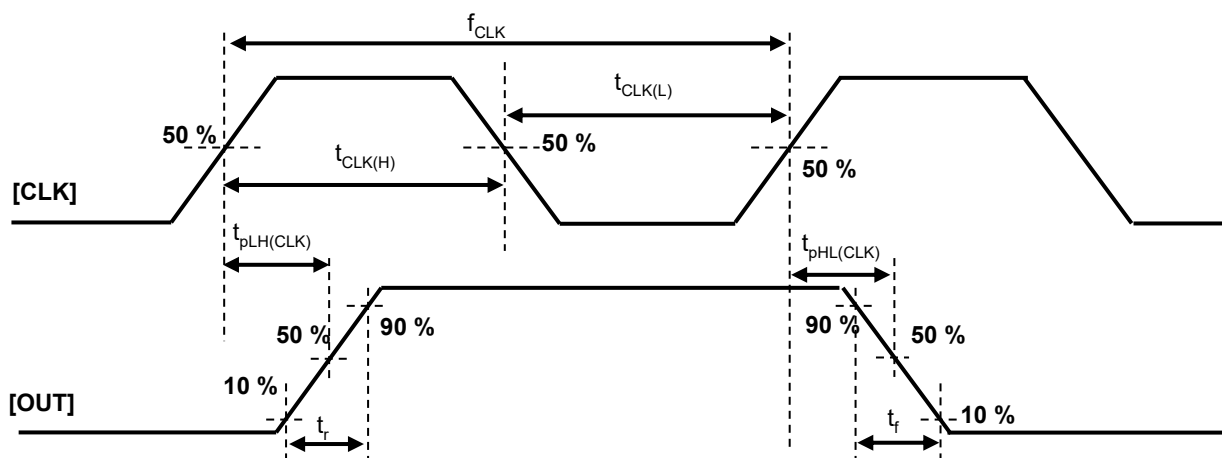

Figure9.1 TB67S539FTG(Relationship between CLK and output)

Note: Timing charts may be simplified for explanatory purpose.

TB67S539FTG (Relation between CLK and other control signal)

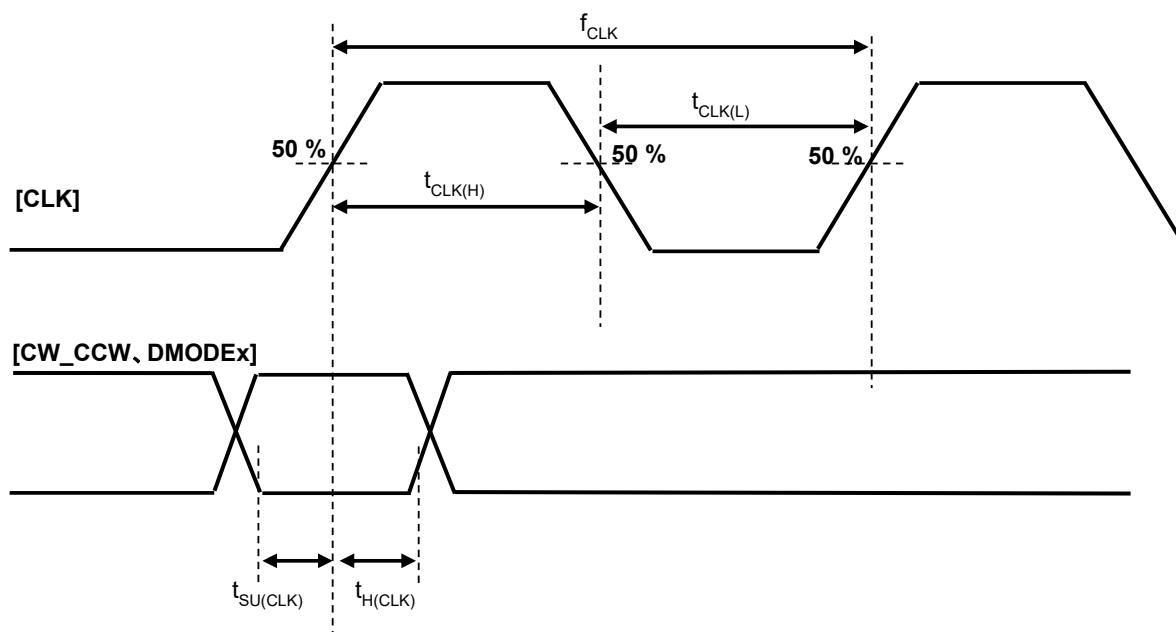

Figure9.2 TB67S539FTG(Relationship between CLK and other control signals)

Note: Timing charts may be simplified for explanatory purpose.

10. Application Circuit Example

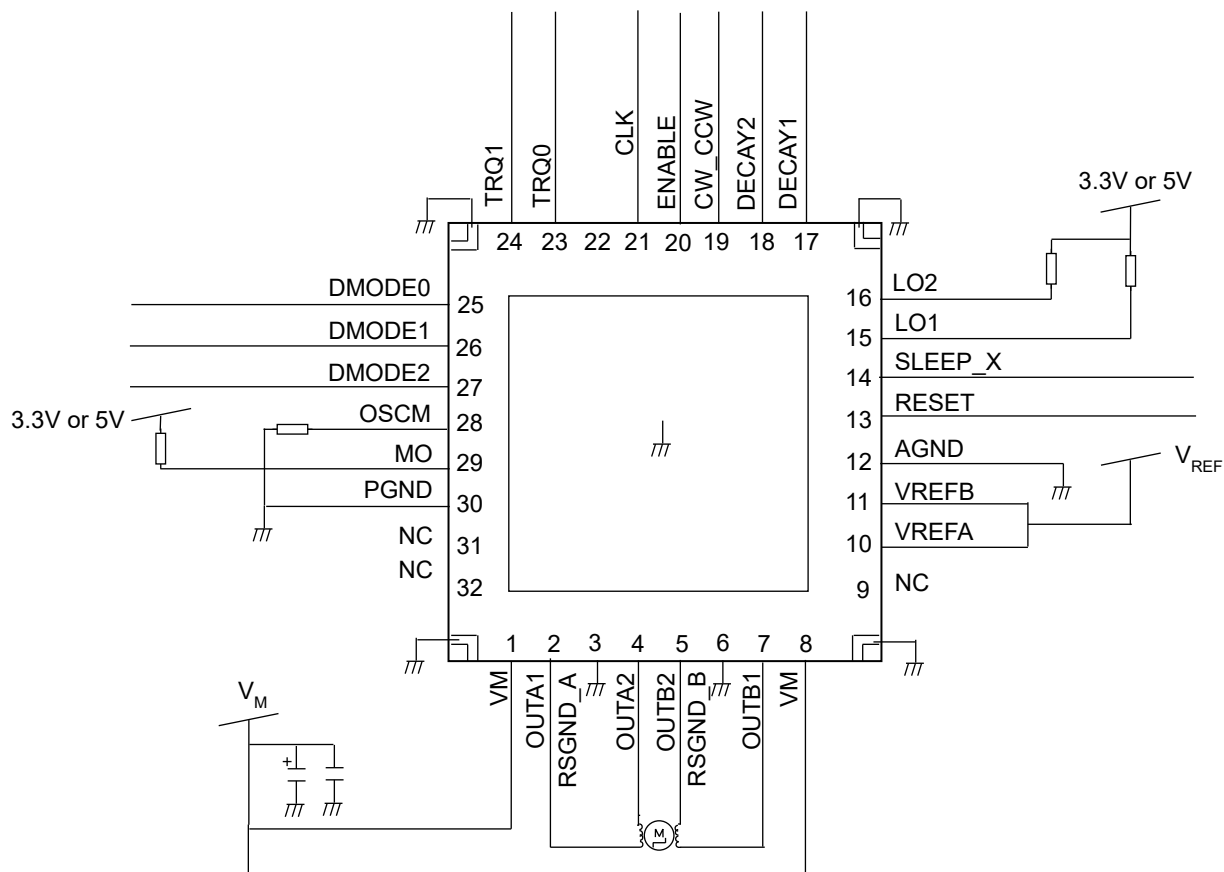

Figure10 Application Circuit Example

Note: Heat dissipation PAD (4 corners and the center part) on the back of the package is recommended to connect to the GND of the board for improved heat dissipation.
The application circuit example may be simplified or some parts of them may be omitted for explanatory purposes.

Note on Contents

1. Block Diagrams

Some of the functional blocks, circuits, or constants in the block diagram may be omitted or simplified for explanatory purposes.

2. Timing Charts

Timing charts may be simplified for explanatory purposes.

3. Application Circuit Example

The application circuits shown in this document are provided for reference purposes only. Thorough evaluation is required, especially at the mass production design stage.

Providing these application circuit examples does not grant a license for industrial property rights.

11. IC Usage Considerations

11.1. Notes on Handling of ICs

- (1) The absolute maximum ratings of a semiconductor device are a set of ratings that must not be exceeded, even for a moment. Do not exceed any of these ratings. Exceeding the rating(s) may cause the device breakdown, damage or deterioration, and may result injury by explosion or combustion.
- (2) Do not insert devices in the wrong orientation or incorrectly. Make sure that the positive and negative terminals of power supplies are connected properly. Otherwise, the current or power consumption may exceed the absolute maximum rating, and exceeding the rating(s) may cause the device breakdown, damage or deterioration, and may result injury by explosion or combustion. In addition, do not use any device that is applied the current with inserting in the wrong orientation or incorrectly even just one time.
- (3) Use an appropriate power supply fuse to ensure that a large current does not continuously flow in case of over-current and/or IC failure. The IC will fully break down when used under conditions that exceed its absolute maximum ratings, when the wiring is routed improperly or when an abnormal pulse noise occurs from the wiring or load, causing a large current to continuously flow and the breakdown can lead smoke or ignition. To minimize the effects of the flow of a large current in case of breakdown, appropriate settings, such as fuse capacity, fusing time and insertion circuit location, are required.
- (4) If your design includes an inductive load such as a motor coil, incorporate a protection circuit into the design to prevent device malfunction or breakdown caused by the current resulting from the inrush current at power ON or the negative current resulting from the back electromotive force at power OFF. IC breakdown may cause injury, smoke or ignition. Use a stable power supply with ICs with built-in protection functions. If the power supply is unstable, the protection function may not operate, causing IC breakdown. IC breakdown may cause injury, smoke or ignition.
- (5) Carefully select external components (such as inputs and negative feedback capacitors) and load components (such as speakers), for example, power amp and regulator. If there is a large amount of leakage current such as input or negative feedback condenser, the IC output DC voltage will increase. If this output voltage is connected to a speaker with low input withstand voltage, over-current or IC failure can cause smoke or ignition. (The over-current can cause smoke or ignition from the IC itself.) In particular, please pay attention when using a Bridge Tied Load (BTL) connection type IC that inputs output DC voltage to a speaker directly.

11.2. Points to Remember on Handling of ICs

(1) Over-current detection circuit

Over-current detection circuits (referred to as current limiter circuits) do not necessarily protect ICs under all circumstances. If the over-current protection circuits operate against the over-current, clear the over-current status immediately.

Depending on the method of use and usage conditions, such as exceeding absolute maximum ratings can cause the over-current protection circuit to not operate properly or IC breakdown before operation. In addition, depending on the method of use and usage conditions, if over-current continues to flow for a long time after operation, the IC may generate heat resulting in breakdown.

(2) Thermal shutdown circuit

Thermal shutdown circuits do not necessarily protect ICs under all circumstances. If the thermal shutdown circuits operate against the over temperature, clear the heat generation status immediately.

Depending on the method of use and usage conditions, such as exceeding absolute maximum ratings can cause the thermal shutdown circuit to not operate properly or IC breakdown before operation.

(3) Heat radiation design

In using an IC with large current flow such as power amp, regulator or driver, please design the device so that heat is appropriately radiated, not to exceed the specified junction temperature (T_j) at any time and condition. These ICs generate heat even during normal use. An inadequate IC heat radiation design can lead to decrease in IC life, deterioration of IC characteristics or IC breakdown. In addition, please design the device taking into consideration the effect of IC heat radiation with peripheral components.

(4) Back-EMF

When a motor reverses the rotation direction, stops or slows down abruptly, a current flow back to the motor's power supply due to the effect of back-EMF. If the current sink capability of the power supply is small, the device's motor power supply and output pins might be exposed to conditions beyond absolute maximum ratings. To avoid this problem, take the effect of back-EMF into consideration in system design.

12. Package Information

12.1. Package Dimensions

P-VQFN32-0505-0.50-004

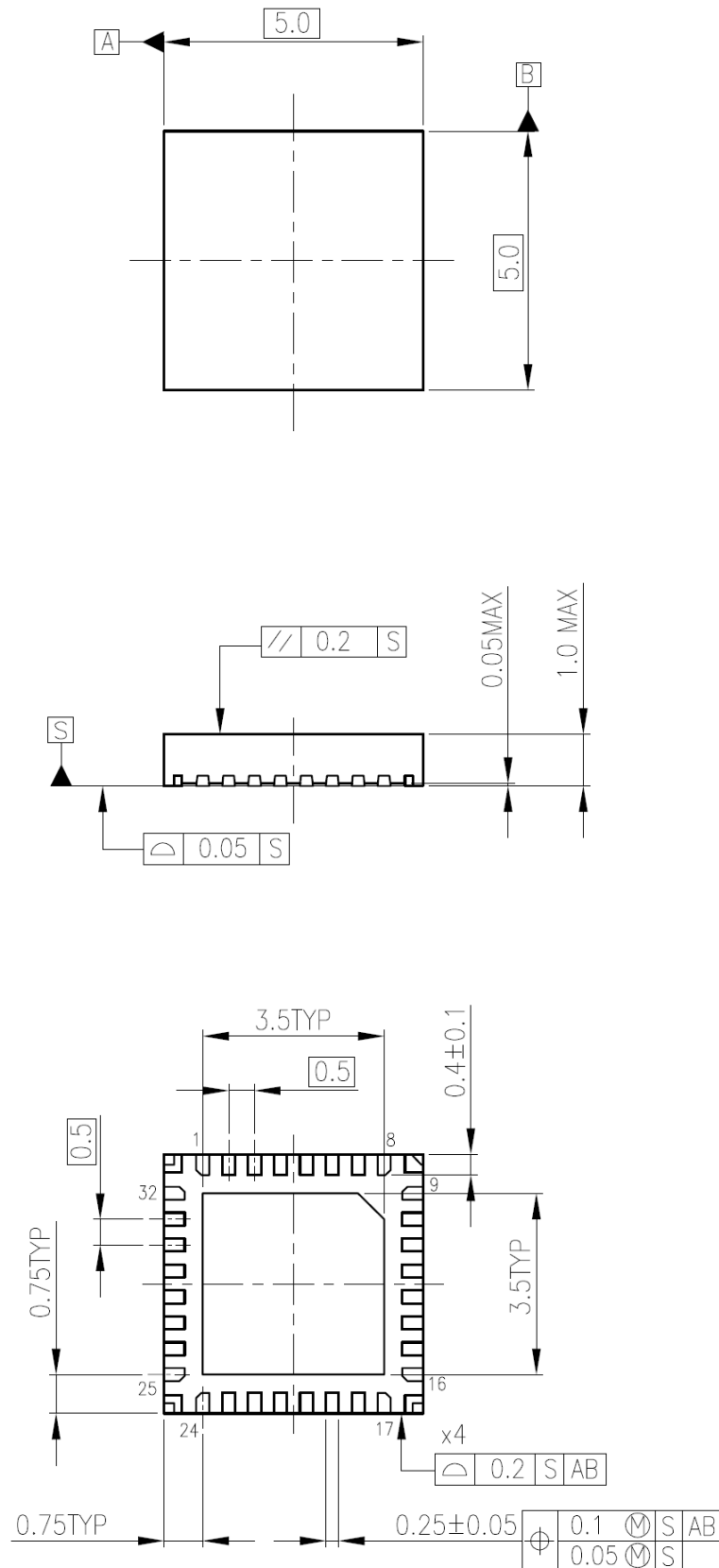

Weight: 0.066 g (typ.)

RESTRICTIONS ON PRODUCT USE

Toshiba Corporation and its subsidiaries and affiliates are collectively referred to as "TOSHIBA". Hardware, software and systems described in this document are collectively referred to as "Product".

- TOSHIBA reserves the right to make changes to the information in this document and related Product without notice.
- This document and any information herein may not be reproduced without prior written permission from TOSHIBA. Even with TOSHIBA's written permission, reproduction is permissible only if reproduction is without alteration/omission.
- Though TOSHIBA works continually to improve Product's quality and reliability, Product can malfunction or fail. Customers are responsible for complying with safety standards and for providing adequate designs and safeguards for their hardware, software and systems which minimize risk and avoid situations in which a malfunction or failure of Product could cause loss of human life, bodily injury or damage to property, including data loss or corruption. Before customers use the Product, create designs including the Product, or incorporate the Product into their own applications, customers must also refer to and comply with (a) the latest versions of all relevant TOSHIBA information, including without limitation, this document, the specifications, the data sheets and application notes for Product and the precautions and conditions set forth in the "TOSHIBA Semiconductor Reliability Handbook" and (b) the instructions for the application with which the Product will be used with or for. Customers are solely responsible for all aspects of their own product design or applications, including but not limited to (a) determining the appropriateness of the use of this Product in such design or applications; (b) evaluating and determining the applicability of any information contained in this document, or in charts, diagrams, programs, algorithms, sample application circuits, or any other referenced documents; and (c) validating all operating parameters for such designs and applications. **TOSHIBA ASSUMES NO LIABILITY FOR CUSTOMERS' PRODUCT DESIGN OR APPLICATIONS.**
- **PRODUCT IS NEITHER INTENDED NOR WARRANTED FOR USE IN EQUIPMENTS OR SYSTEMS THAT REQUIRE EXTRAORDINARILY HIGH LEVELS OF QUALITY AND/OR RELIABILITY, AND/OR A MALFUNCTION OR FAILURE OF WHICH MAY CAUSE LOSS OF HUMAN LIFE, BODILY INJURY, SERIOUS PROPERTY DAMAGE AND/OR SERIOUS PUBLIC IMPACT ("UNINTENDED USE").** Except for specific applications as expressly stated in this document, Unintended Use includes, without limitation, equipment used in nuclear facilities, equipment used in the aerospace industry, lifesaving and/or life supporting medical equipment, equipment used for automobiles, trains, ships and other transportation, traffic signaling equipment, equipment used to control combustions or explosions, safety devices, elevators and escalators, and devices related to power plant. **IF YOU USE PRODUCT FOR UNINTENDED USE, TOSHIBA ASSUMES NO LIABILITY FOR PRODUCT.** For details, please contact your TOSHIBA sales representative or contact us via our website.
- Do not disassemble, analyze, reverse-engineer, alter, modify, translate or copy Product, whether in whole or in part.
- Product shall not be used for or incorporated into any products or systems whose manufacture, use, or sale is prohibited under any applicable laws or regulations.
- The information contained herein is presented only as guidance for Product use. No responsibility is assumed by TOSHIBA for any infringement of patents or any other intellectual property rights of third parties that may result from the use of Product. No license to any intellectual property right is granted by this document, whether express or implied, by estoppel or otherwise.
- **ABSENT A WRITTEN SIGNED AGREEMENT, EXCEPT AS PROVIDED IN THE RELEVANT TERMS AND CONDITIONS OF SALE FOR PRODUCT, AND TO THE MAXIMUM EXTENT ALLOWABLE BY LAW, TOSHIBA (1) ASSUMES NO LIABILITY WHATSOEVER, INCLUDING WITHOUT LIMITATION, INDIRECT, CONSEQUENTIAL, SPECIAL, OR INCIDENTAL DAMAGES OR LOSS, INCLUDING WITHOUT LIMITATION, LOSS OF PROFITS, LOSS OF OPPORTUNITIES, BUSINESS INTERRUPTION AND LOSS OF DATA, AND (2) DISCLAIMS ANY AND ALL EXPRESS OR IMPLIED WARRANTIES AND CONDITIONS RELATED TO SALE, USE OF PRODUCT, OR INFORMATION, INCLUDING WARRANTIES OR CONDITIONS OF MERCHANTABILITY, FITNESS FOR A PARTICULAR PURPOSE, ACCURACY OF INFORMATION, OR NONINFRINGEMENT.**
- Do not use or otherwise make available Product or related software or technology for any military purposes, including without limitation, for the design, development, use, stockpiling or manufacturing of nuclear, chemical, or biological weapons or missile technology products (mass destruction weapons). Product and related software and technology may be controlled under the applicable export laws and regulations including, without limitation, the Japanese Foreign Exchange and Foreign Trade Law and the U.S. Export Administration Regulations. Export and re-export of Product or related software or technology are strictly prohibited except in compliance with all applicable export laws and regulations.
- Please contact your TOSHIBA sales representative for details as to environmental matters such as the RoHS compatibility of Product. Please use Product in compliance with all applicable laws and regulations that regulate the inclusion or use of controlled substances, including without limitation, the EU RoHS Directive. **TOSHIBA ASSUMES NO LIABILITY FOR DAMAGES OR LOSSES OCCURRING AS A RESULT OF NONCOMPLIANCE WITH APPLICABLE LAWS AND REGULATIONS.**